

## Resistor-Programmable Temperature Switches

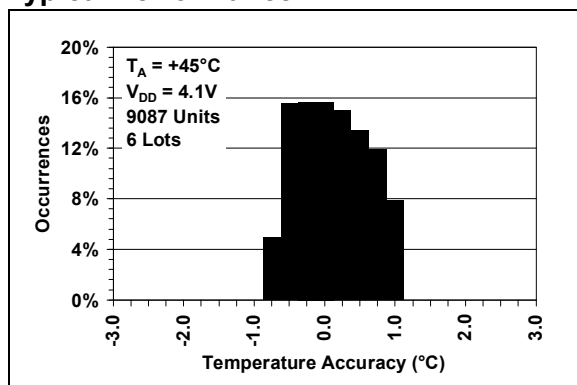
### Features

- Resistor-Programmable Temperature Switch
- Wide Operating Voltage Range: 2.7V to 5.5V
- Low Supply Current: 30  $\mu$ A (typical)
- Temperature Switch Accuracy:
  - $\pm 0.5^\circ\text{C}$  (typical) at  $+25^\circ\text{C}$ ,  $+45^\circ\text{C}$
  - $\pm 1^\circ\text{C}$  (typical)  $0^\circ\text{C}$  to  $+70^\circ\text{C}$
  - $\pm 3.5^\circ\text{C}$  (maximum)  $0^\circ\text{C}$  to  $+125^\circ\text{C}$
  - $\pm 4.5^\circ\text{C}$  (maximum)  $-20^\circ\text{C}$  to  $+125^\circ\text{C}$
  - $\pm 2^\circ\text{C}$  (typical)  $-40^\circ\text{C}$  to  $+125^\circ\text{C}$
- Sensor Options available:
  - Switch for rising temperature: Cold to Hot (H)
  - Switch for falling temperature: Hot to Cold (C)
- Output Configurations:
  - Open-Drain:
    - External Pull-up Resistor: MCP9509
    - Internal Pull-up Resistor: MCP9510
  - Active-Low, Push-Pull: MCP9510
  - Active-High, Push-Pull: MCP9510
- User Selectable Hysteresis:  $2^\circ\text{C}$  or  $10^\circ\text{C}$  (typical)
- Space-Saving SOT-23-5, SOT-23-6 Packages

### Applications

- Power Supply Thermal Shutdown
- Temperature Alarm
- Thermostat Control
- Fan Control
- Base-Stations
- Automotive

### Typical Performance

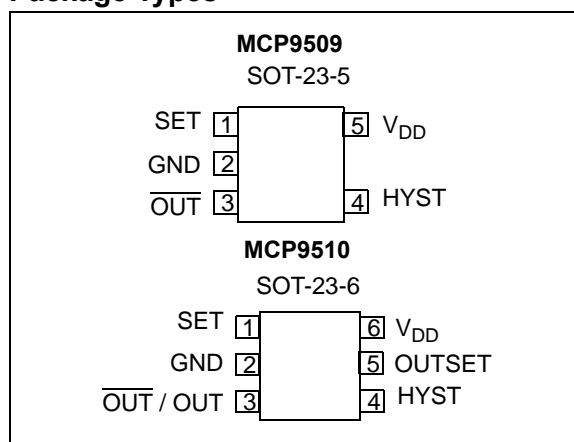


### Description

Microchip Technology's MCP9509/10 devices are programmable logic output temperature switches. The temperature switch threshold can be programmed with a single external resistor, which provides high design flexibility and simplicity. In addition, this family of devices provide user programmable features such as  $2^\circ\text{C}$  and  $10^\circ\text{C}$  (typical) switch hysteresis and output structure configuration. The MCP9509 provides an open drain output, whereas the MCP9510 is offered in three different user selectable output configurations: Active-low/Active-high push pull and Active-Low Open-Drain output with an internal  $100\text{ k}\Omega$  pull-up resistor.

The MCP9509/10 operate from 2.7V to 5.5V. This family is capable of triggering for temperatures  $-40^\circ\text{C}$  to  $+125^\circ\text{C}$  with high accuracy.

### Package Types



# MCP9509/10

---

NOTES:

## 1.0 ELECTRICAL CHARACTERISTICS

### Absolute Maximum Ratings †

V <sub>DD</sub> .....	6.0V
Voltage at all Input/Output pins .....	GND – 0.3V to 6.0V
Input/Output Current .....	20 mA
Storage temperature .....	-65°C to +150°C
Ambient temp. with power applied .....	-40°C to +125°C
Junction Temperature (T <sub>J</sub> ) .....	+150°C
ESD protection on all pins (HBM:MM) .....	(4 kV/400V)
Latch-Up Current at each pin (25°C) .....	±200 mA

†**Notice:** Stresses above those listed under “Maximum ratings” may cause permanent damage to the device. This is a stress rating only and functional operation of the device at those or any other conditions above those indicated in the operational listings of this specification is not implied. Exposure to maximum rating conditions for extended periods may affect device reliability.

### DC CHARACTERISTICS

**Electrical Specifications:** Unless otherwise indicated, V<sub>DD</sub> = 2.7V to 5.5V, T<sub>A</sub> = -40°C to +125°C, and GND = Ground.

Parameters	Sym	Min	Typ	Max	Unit	Conditions
<b>Sensor Accuracy</b>						
T <sub>A</sub> = +25°C, +45°C	T <sub>ACY</sub>	—	±0.5	—	°C	<b>Note 1</b>
0°C ≤ T <sub>A</sub> ≤ +125°C		-3.5	±1	+3.5	°C	
-20°C ≤ T <sub>A</sub> ≤ +125°C		-4.5	±1	+4.5	°C	
-40°C ≤ T <sub>A</sub> ≤ +125°C		—	±2	—	°C	
<b>Power Supply</b>						
Operating Voltage	V <sub>DD</sub>	2.7	—	5.5	V	
Operating Current (MCP9509)	I <sub>DD</sub>	—	30	50	µA	
Operating Current (MCP9510)	I <sub>DD</sub>	—	50	80	µA	OUTSET = GND or V <sub>DD</sub>
		—	100	165	µA	OUTSET = Unconnected
<b>Hysteresis</b>						
Trip Point Hysteresis	T <sub>HYST</sub>	—	+2	—	°C	HYST = GND
		—	+10	—	°C	HYST = V <sub>DD</sub>
Hysteresis Select: Input (HYST) Thresholds	V <sub>IH</sub>	V <sub>DD</sub> - 0.4	—	—	V	
	V <sub>IL</sub>	—	—	0.4	V	
Hysteresis Input (HYST) Leakage	I <sub>Leak</sub>	—	1	—	µA	
<b>MCP9510 Output Control Input (OUTSET Input)</b>						
OUTSET Input Voltage Threshold and Output Configuration						
Push-Pull, Active Low	V <sub>OSET</sub>	GND	—	0.2V <sub>DD</sub>	V	or OUTSET Unconnected
Open-Drain with R <sub>OUT</sub> , Active Low		0.45V <sub>DD</sub>	—	0.7V <sub>DD</sub>	V	
Push-Pull, Active High		0.85V <sub>DD</sub>	—	V <sub>DD</sub>	V	
OUTSET Input Leakage and Output Configuration						
Push-Pull, Active Low	I <sub>Leak</sub>	—	10	—	µA	GND ≤ V <sub>OSET</sub> ≤ 0.2V <sub>DD</sub>
Open-Drain, Active Low		—	0	—	µA	Unconnected (i.e. open)
		—	7	—	µA	0.4V <sub>DD</sub> ≤ V <sub>OSET</sub> ≤ 0.7V <sub>DD</sub>
Push-Pull, Active High		—	-10	—	µA	0.85 ≤ V <sub>OSET</sub> ≤ V <sub>DD</sub>
OUTSET Input Impedance	Z <sub>OUTSET</sub>	—	500	—	kΩ	

**Note 1:** This specification is tested at mid supply of 4.1V for optimum operation across the supply voltage range of 2.7V to 5.5V.

# MCP9509/10

## DC CHARACTERISTICS (CONTINUED)

**Electrical Specifications:** Unless otherwise indicated,  $V_{DD} = 2.7V$  to  $5.5V$ ,  $T_A = -40^{\circ}C$  to  $+125^{\circ}C$ , and GND = Ground.

Parameters	Sym	Min	Typ	Max	Unit	Conditions
<b>Outputs (OUT, <math>\overline{OUT}</math>)</b>						
Output Voltage High, MCP9510	$V_{OH}$	$V_{DD} - 0.55$	—	$V_{DD}$	V	$I_{OUT} = 5\text{ mA}$ OUTSET = $V_{DD}$ or GND
Output Voltage Low, MCP9510	$V_{OL}$	GND	—	0.3	V	
Output Voltage Low, MCP9509	$V_{OL}$	GND	—	0.3	V	$I_{OUT} = 5\text{ mA}$
Internal Output Pull-up (MCP9510)	$R_{OUT}$	60	100	140	k $\Omega$	OUTSET Unconnected
Open-Drain Output Leakage	$I_{Leak}$	—	1	—	$\mu A$	MCP9509/10
Power Supply Rejection	PSR	—	0.05	—	$^{\circ}C/V$	
<b>Thermal Response</b>						
SOT23-5, SOT23-6	$t_{RES}$	—	1.7	—	s	Time to 63% (88 $^{\circ}C$ ). +25 $^{\circ}C$ (Air) to +125 $^{\circ}C$ (oil bath)

**Note 1:** This specification is tested at mid supply of 4.1V for optimum operation across the supply voltage range of 2.7V to 5.5V.

## TEMPERATURE CHARACTERISTICS

**Electrical Specifications:** Unless otherwise indicated,  $V_{DD} = 2.7V$  to  $5.5V$ ,  $T_A = -40^{\circ}C$  to  $+125^{\circ}C$ , and GND = Ground.

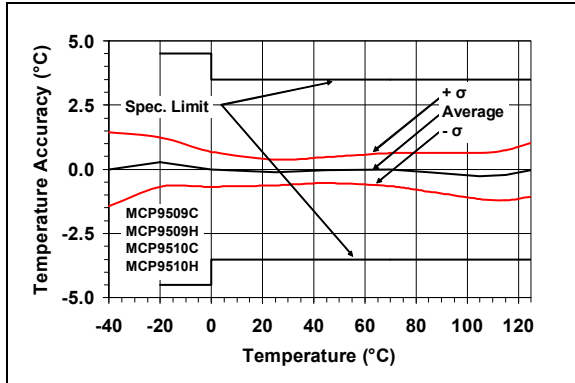
Parameters	Sym	Min	Typ	Max	Units	Conditions
<b>Temperature Ranges</b>						
Specified Temperature Range	$T_A$	-40	—	+125	$^{\circ}C$	(Note 1)
Operating Temperature Range	$T_A$	-40	—	+125	$^{\circ}C$	
Storage Temperature Range	$T_A$	-65	—	+150	$^{\circ}C$	
<b>Thermal Package Resistances</b>						
Thermal Resistance, 5L-SOT23	$\theta_{JA}$	—	220.7	—	$^{\circ}C/\Omega$	
Thermal Resistance, 6L-SOT23	$\theta_{JA}$	—	190.5	—	$^{\circ}C/\Omega$	

**Note 1:** Operation in this range must not cause  $T_J$  to exceed Maximum Junction Temperature (+150 $^{\circ}C$ ).

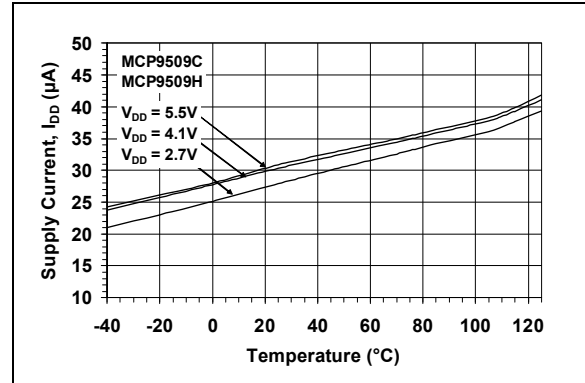
## 2.0 TYPICAL PERFORMANCE CURVES

**Note:** The graphs and tables provided following this note are a statistical summary based on a limited number of samples and are provided for informational purposes only. The performance characteristics listed herein are not tested or guaranteed. In some graphs or tables, the data presented may be outside the specified operating range (e.g., outside specified power supply range) and therefore outside the warranted range.

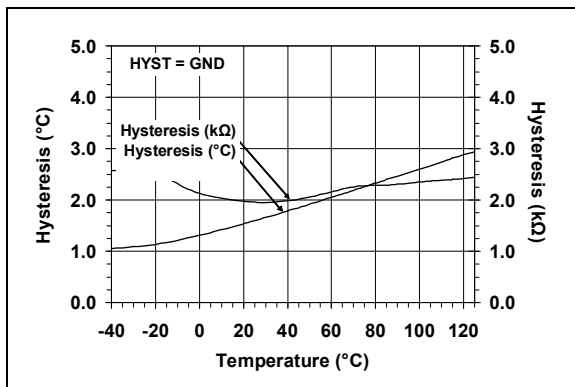
**Note:** Unless otherwise indicated,  $V_{DD} = 2.7V$  to  $5.5V$ ,  $T_A = -40^{\circ}C$  to  $+125^{\circ}C$ , GND = Ground,  $R_{PULL-UP} = 10\text{ k}\Omega$  (MCP9509 only) and  $0.1\text{ }\mu\text{F}$  bypass capacitor.



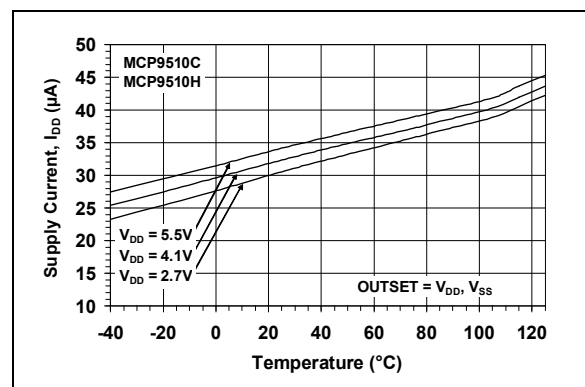
**FIGURE 2-1:** Temperature Accuracy.



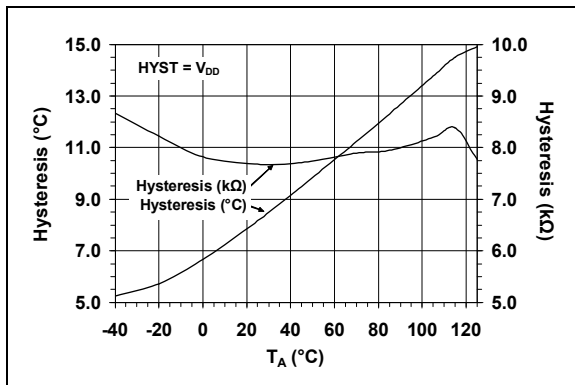
**FIGURE 2-4:** Supply Current vs. Temperature (MCP9509).



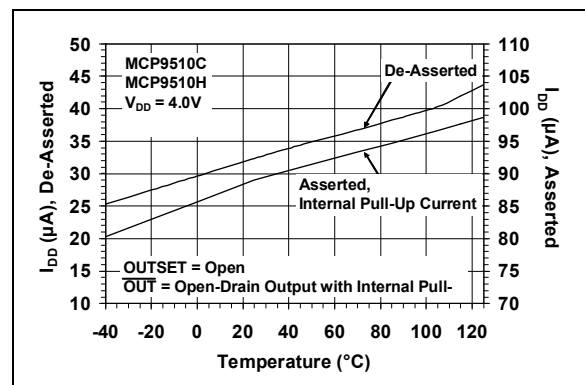
**FIGURE 2-2:** Output Hysteresis vs. Temperature.



**FIGURE 2-5:** Supply Current vs. Temperature  $OUTSET = V_{DD}, V_{SS}$  (MCP9510).



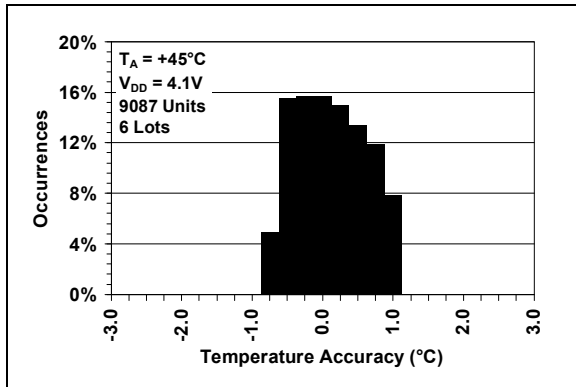
**FIGURE 2-3:** Output Hysteresis vs. Temperature.



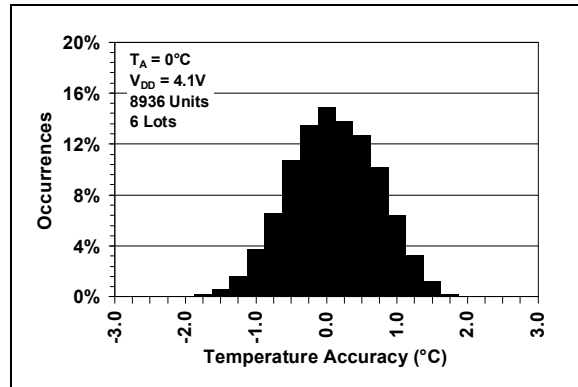
**FIGURE 2-6:** Supply Current vs. Temperature  $OUTSET = \text{Unconnected, Open}$  (MCP9510).

# MCP9509/10

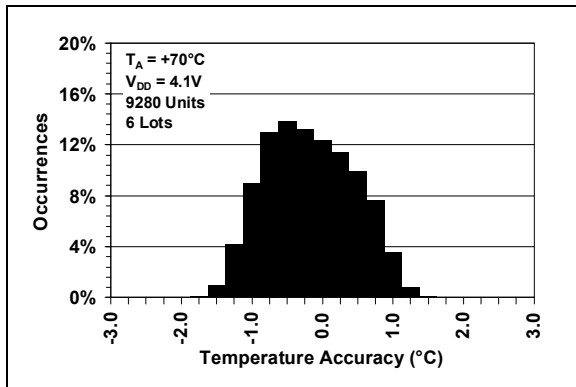
**Note:** Unless otherwise indicated,  $V_{DD} = 2.7V$  to  $5.5V$ ,  $T_A = -40^{\circ}C$  to  $+125^{\circ}C$ , GND = Ground,  $R_{PULL-UP} = 10\text{ k}\Omega$  (MCP9509 only) and  $0.1\text{ }\mu\text{F}$  bypass capacitor.



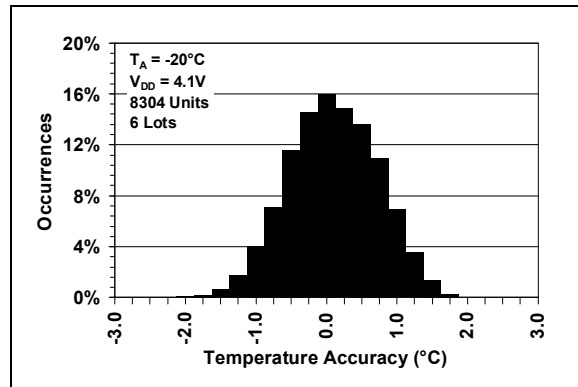
**FIGURE 2-7:** Temperature Accuracy Histogram at  $+45^{\circ}C$ .



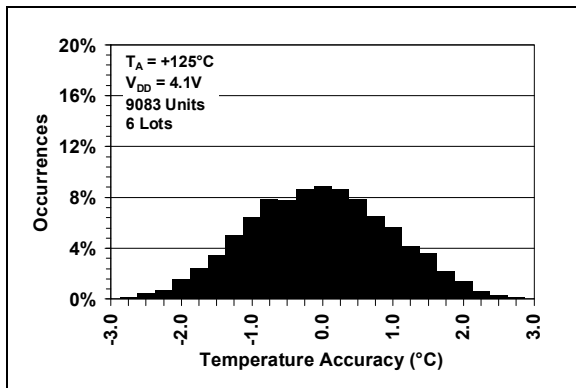
**FIGURE 2-10:** Temperature Accuracy Histogram at  $0^{\circ}C$ .



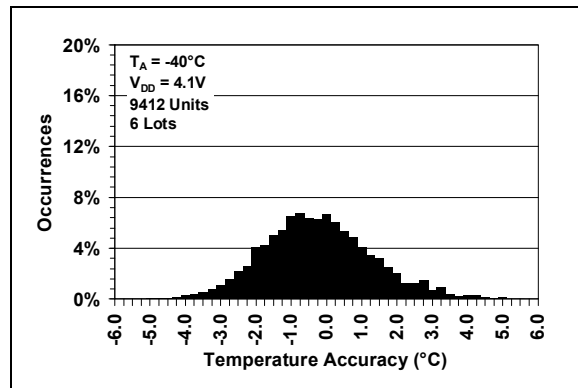
**FIGURE 2-8:** Temperature Accuracy Histogram at  $+70^{\circ}C$ .



**FIGURE 2-11:** Temperature Accuracy Histogram at  $-20^{\circ}C$ .

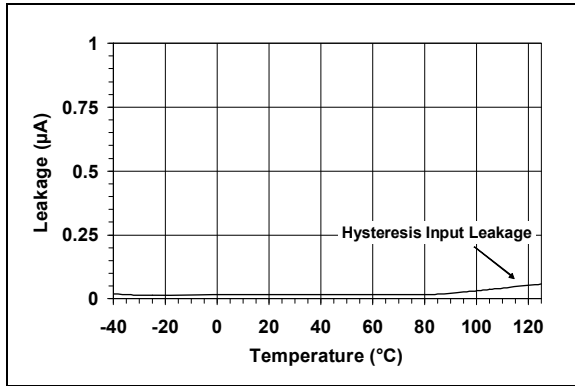


**FIGURE 2-9:** Temperature Accuracy Histogram at  $+125^{\circ}C$ .

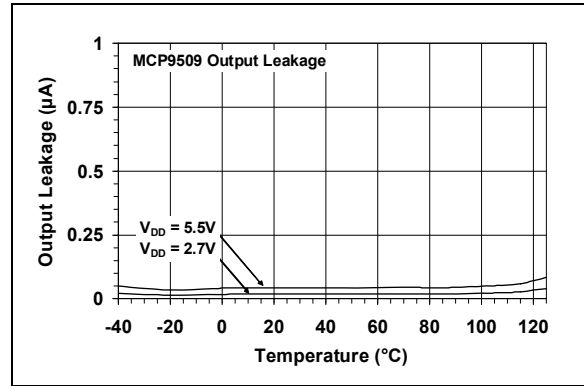


**FIGURE 2-12:** Temperature Accuracy Histogram at  $-40^{\circ}C$ .

**Note:** Unless otherwise indicated,  $V_{DD} = 2.7V$  to  $5.5V$ ,  $T_A = -40^{\circ}C$  to  $+125^{\circ}C$ ,  $GND = \text{Ground}$ ,  $R_{PULL-UP} = 10\text{ k}\Omega$  (MCP9509 only) and  $0.1\text{ }\mu\text{f}$  bypass capacitor.



**FIGURE 2-13:** Hysteresis Input Leakage vs. Temperature.



**FIGURE 2-14:** Output Leakage vs. Temperature.

# MCP9509/10

---

NOTES:

## 3.0 PIN DESCRIPTIONS

**TABLE 3-1: PIN FUNCTION TABLE**

MCP9509	MCP9510	Symbol	Description
SOT-23-5	SOT-23-6		
1	1	SET	External Trip Temperature Resistor ( $R_{SET}$ ) input
2	2	GND	Ground
3	—	$\overline{OUT}$	Open-drain output
—	3	OUT, $\overline{OUT}$	Selectable Output pin, function set by OUTSET pin
4	4	HYS	Hysteresis Input HYS = GND, hysteresis is 2°C HYS = $V_{DD}$ , hysteresis is 10°C
5	6	$V_{DD}$	Power pin
—	5	OUTSET	Output Control OUTSET = GND, Active-Low, Push-Pull OUTSET = $V_{DD}$ , Active-High, Push-Pull OUTSET = Unconnected, Active-Low, Open-Drain with an internal pull-up

### 3.1 External Resistor Input (SET)

This pin is used to connect a resistor between the SET and GND pins to select the temperature trip point ( $T_{SET}$ ). The resistor value can be determined either from [Equation 4-2](#) or the lookup table shown in [Table 4-2](#).

### 3.2 Ground (GND)

The GND pin is the system ground pin.

### 3.3 Hysteresis Input (HYS)

This is an input pin which can be connected to  $V_{DD}$  or GND to select output hysteresis. Either 2°C (HYS = GND) or 10°C (HYS =  $V_{DD}$ ) of hysteresis can be selected.

### 3.4 Power Pin ( $V_{DD}$ )

The operating voltage range, as specified in the DC electrical specification table, is applied on this pin.

### 3.5 Open-Drain Output ( $\overline{OUT}$ ) (MCP9509)

This output is triggered when temperature exceeds the programmed trip temperature. This pin requires a pull-up resistor.

### 3.6 Selectable Output (OUT, $\overline{OUT}$ ) (MCP9510)

The output pin can be configured as either a Push-Pull Active-High, Push-Pull Active-Low, or an Open-drain Output with an internal pull-up resistor. The three output options of the MCP9510 are selected by the OUTSET pin.

### 3.7 Output Control (OUTSET) (MCP9510)

The OUTSET pin is used to select the desired configuration of the OUT or  $\overline{OUT}$  pin.

**TABLE 3-1: OUTSET SELECTABLE OUTPUTS**

OUTSET Pin	OUT / $\overline{OUT}$ Pin
GND	Push-Pull, Active-Low
$V_{DD}$	Push-Pull, Active-High
unconnected (i.e. open)	Open-Drain output with an internal pull-up resistor of 100 k $\Omega$ (typical)

# MCP9509/10

---

NOTES:

## 4.0 FUNCTIONAL DESCRIPTION

The MCP9509/10 integrates a temperature switch with a user programmable threshold. The temperature switch threshold or alert limit is programmed using an external resistor  $R_{SET}$ . A logic signal is asserted when the die temperature crosses the programmed alert limit. The MCP9509 has an Open-Drain output which requires an external pull-up resistor for operation. The MCP9510 output can be configured to three user selectable output configurations. The OUTSET pin is used to select Active-Low Push-Pull, Active-Low Open-Drain (with internal  $100\text{ k}\Omega$  pull-up resistor), Active-High Push-Pull output configurations. In addition, this device provides user selectable hysteresis of  $2^\circ\text{C}$  and  $10^\circ\text{C}$  (typical).

### 4.1 SET Input Pin

The SET input pin is used to connect an external resistor  $R_{SET}$ . The resistor sets the alert threshold. The SET pin outputs a constant current  $I_{SET}$  ( $\sim 5\text{ }\mu\text{A}$ ) to bias  $R_{SET}$  (Shown in Figure 4-1). The voltage across  $R_{SET}$ ,  $V_{SET}$ , is compared to an internal thermal diode.

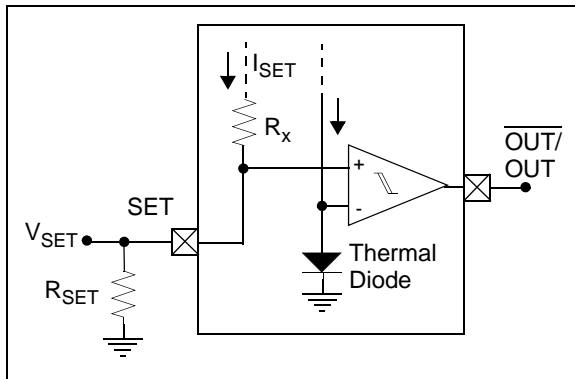


FIGURE 4-1: SET input.

When the thermal diode voltage exceeds  $V_{SET}$ , the sensor output asserts. The assert polarity is determined by the state of the OUTSET pin.

### 4.2 MCP9510 OUTSET Input Pin

This pin is used to select the device output configuration. This feature enables in-circuit device output configuration by driving this pin with a microcontroller I/O pin to Output-HIGH, Output-LOW, or High-Impedance input. Figure 4-4 shows the configuration and output conditions.

The input structure of this pin consists of a resistor ladder and comparators to determine OUTSET level threshold. Figure 4-2 shows the circuit configuration. The OUTSET input resistance must be carefully considered for leakage current when connecting voltage source to change output configuration.

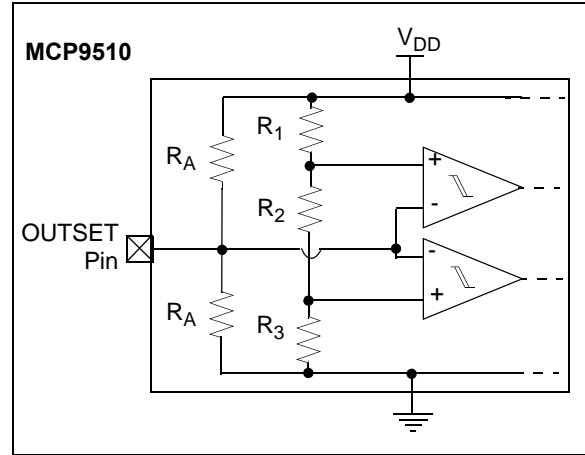


FIGURE 4-2: MCP9510 OUTSET Input Structure.

The OUTSET pin input impedance  $Z_{OUTSET}$  is set by the internal resistance  $R_A = 1\text{ M}\Omega$  (typical). The input structure is a voltage divider network from  $V_{DD}$ . Therefore, the leakage current on the OUTSET pin is a function of change in  $V_{DD}$  and the  $V_{OUTSET}$ .

### 4.3 HYST Input Pin (Hysteresis Select)

The MCP9509/10 family has a user selectable hysteresis input pin HYST. Hysteresis can be externally selected to either  $2^\circ\text{C}$  ( $\text{HYST} = \text{GND}$ ) or  $10^\circ\text{C}$  ( $\text{HYST} = V_{DD}$ ). Figure 4-3 shows graphical description of change in hysteresis.

For example, if the alert temperature threshold is set to  $T_{SET} = 100^\circ\text{C}$  ( $R_{SET} = 16.1\text{ k}\Omega$ ) with an Active-Low output configuration, the output asserts Low when temperature exceeds  $100^\circ\text{C} \pm T_{ACY}$ . The output remains asserted Low until temperature falls below  $T_{HYST}$ ,  $98^\circ\text{C}$  ( $\text{HYST} = \text{GND}$ ) or  $90^\circ\text{C}$  ( $\text{HYST} = V_{DD}$ ).

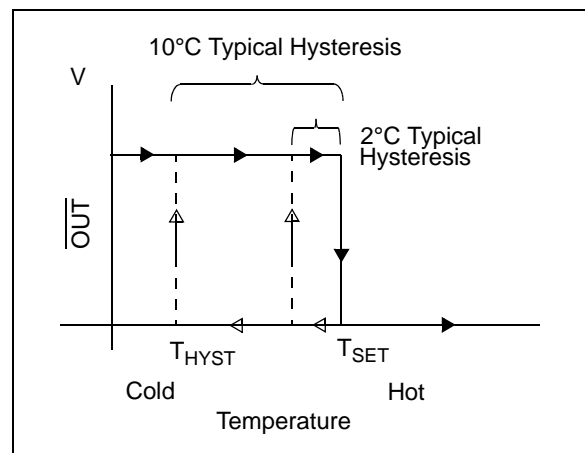


FIGURE 4-3: Output Hysteresis.

# MCP9509/10

## 4.4 Sensor Hot/Cold Options

MCP9509/10 is available with Hot (H) and Cold (C) options. The MCP9509/10 Hot option detects rising temperature while the Cold option detects falling temperature. The output of the Hot option asserts when temperature rises above  $T_{SET}$  and de-asserts when temperature falls below  $T_{HYST}$ . The output of the Cold option asserts when temperature falls below  $T_{SET}$  and de-asserts when temperature rises above  $T_{HYST}$ .

For example, if  $T_{SET} = 100^{\circ}\text{C}$  for Hot option (Active-Low Configuration,  $HYST = V_{DD}$ ), output asserts Low when temperature is greater than  $100^{\circ}\text{C} \pm T_{ACY}$ . The output de-asserts High when temperature is below  $90^{\circ}\text{C}$ . For the Cold option, output asserts Low when temperature is less than  $100^{\circ}\text{C} \pm T_{ACY}$ , and de-asserts when temperature is greater than  $110^{\circ}\text{C}$ . This operation is shown graphically in [Figure 4-4](#).

## 4.5 $R_{SET}$ vs. Temperature

The relation between the user selectable external resistor  $R_{SET}$  and the output trigger threshold limit  $T_{SET}$  is described as shown in **EQUATION 4-1: “ $T_{SET}$  to  $R_{set}$  conversion”** and **EQUATION 4-2: “ $R_{SET}$  to  $T_{set}$  conversion”**. The equation coefficients vary depending on the device output options, H or C. [Table 4-1](#) shows the corresponding coefficients.

**TABLE 4-1: COEFFICIENTS/VARIABLES**

Coef.	MCP9509/10H	MCP9509/10C	Units
$C_{R1}$	-9.84	-10.00	$10^{-6}\text{k}\Omega^{\circ}\text{C}^3$
$C_{R2}$	3.355	3.345	$10^{-3}\text{k}\Omega^{\circ}\text{C}^2$
$C_{R3}$	-0.8648	-0.8610	$\text{k}\Omega^{\circ}\text{C}$
$C_{T1}$	-20.00	-19.7	$10^{-6}^{\circ}\text{C}/\text{k}\Omega^3$
$C_{T2}$	4.136	4.179	$10^{-3}^{\circ}\text{C}/\text{k}\Omega^2$
$C_{T3}$	-1.1564	-1.1617	$^{\circ}\text{C}/\text{k}\Omega$
$R_1$	94.1	95.1	$\text{k}\Omega$
$R_2$	145.5	146.3	$\text{k}\Omega$
$R_3$	2.77	4.25	$\text{k}\Omega$
$T_1$	-40.0		$^{\circ}\text{C}$
$T_2$	125.0		$^{\circ}\text{C}$

### EQUATION 4-1: $T_{SET}$ TO $R_{SET}$ CONVERSION

$$R_{SET} = C_{R1}T_{SET}(T_{SET}-T_1)(T_{SET}-T_2) + C_{R2}(T_{SET}-T_1)(T_{SET}-T_2) + C_{R3}(T_{SET}-T_1) + R_2$$

Where:

$C_{R1,2,3}$  = 1st, 2nd and 3rd order Temperature to Resistance Conversion Coefficients ([Table 4-1](#))

$R_2$  = Resistance ([Table 4-1](#))

$T_{1,2}$  = Temperature ([Table 4-1](#))

### EQUATION 4-2: $R_{SET}$ TO $T_{SET}$ CONVERSION

$$T_{SET} = C_{T1}(R_{SET}-R_1)(R_{SET}-R_2)(R_{SET}-R_3) + C_{T2}(R_{SET}-R_3)(R_{SET}-R_2) + C_{T3}(R_{SET}-R_2) + T_1$$

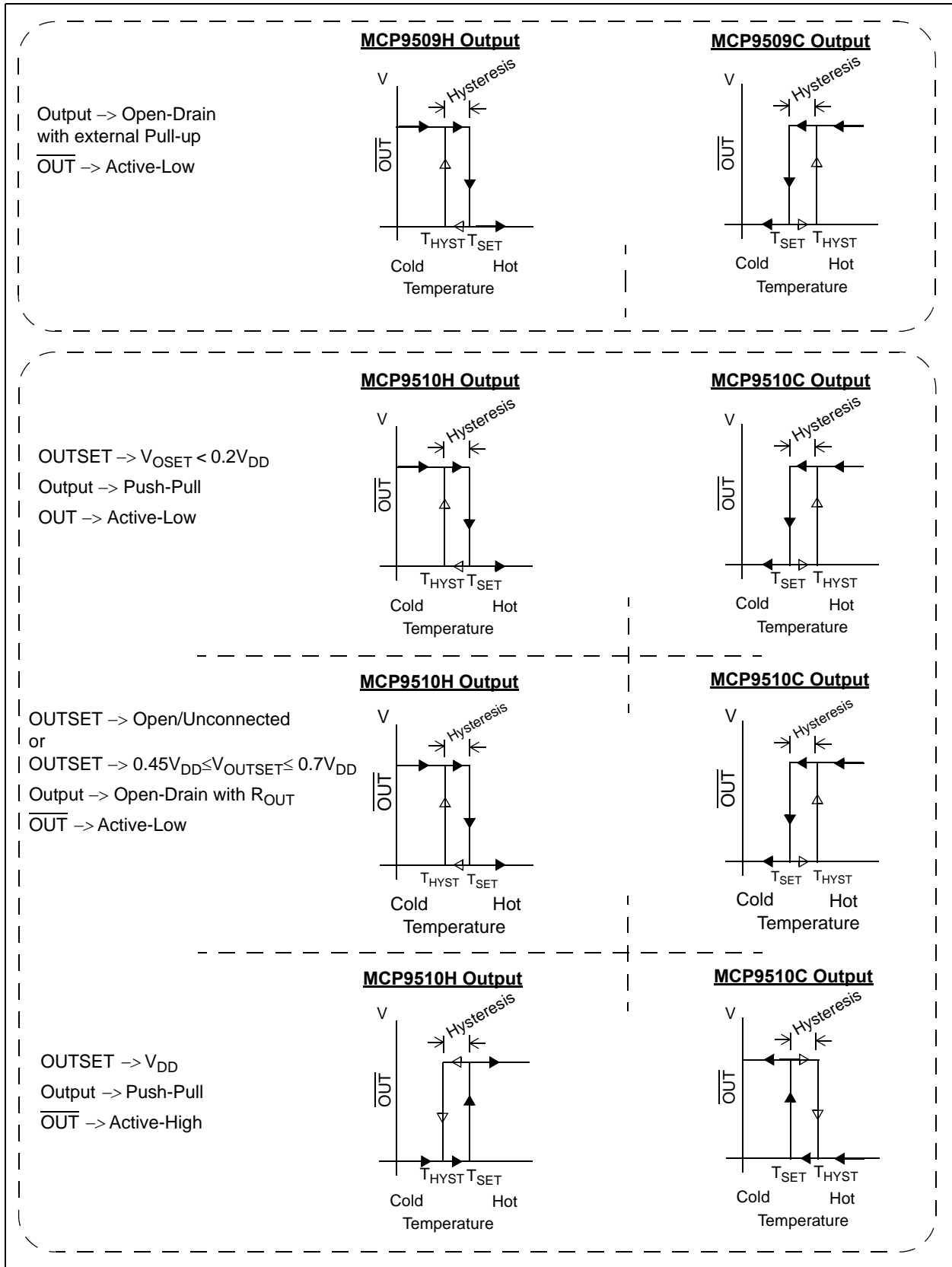
Where:

$C_{C1,2,3}$  = 1st, 2nd and 3rd order Resistance to Temperature Conversion Coefficients ([Table 4-1](#))

$R_{1,2,3}$  = Resistance ([Table 4-1](#))

$T_1$  = Temperature ([Table 4-1](#))

The equations can be used to determine the external resistance value for a specified temperature threshold or threshold value for a specified resistance. [Table 4-2](#) and [Table 4-3](#) show a look-up table which can be used to easily identify the  $T_{SET}$  to  $R_{SET}$  relation for Hot and Cold options.



**FIGURE 4-4:** MCP9509/10  $\overline{\text{OUT}}/\text{OUT}$  Output Configuration.

# MCP9509/10

**TABLE 4-2: T<sub>SET</sub> TO R<sub>SET</sub> CONVERSION TABLE FOR MCP9509/MCP9510H (HOT)**

T <sub>SET</sub> (°C)	R <sub>SET</sub> (kΩ)	T <sub>SET</sub> (°C)	R <sub>SET</sub> (kΩ)	T <sub>SET</sub> (°C)	R <sub>SET</sub> (kΩ)	T <sub>SET</sub> (°C)	R <sub>SET</sub> (kΩ)	T <sub>SET</sub> (°C)	R <sub>SET</sub> (kΩ)	T <sub>SET</sub> (°C)	R <sub>SET</sub> (kΩ)	T <sub>SET</sub> (°C)	R <sub>SET</sub> (kΩ)	T <sub>SET</sub> (°C)	R <sub>SET</sub> (kΩ)	T <sub>SET</sub> (°C)	R <sub>SET</sub> (kΩ)
-40.0	145.5	-20.0	117.9	0.0	94.1	20.0	73.7	40.0	56.2	60.0	41.1	80.0	27.9	100.0	16.1	120.0	5.4
-39.5	144.8	-19.5	117.3	0.5	93.6	20.5	73.2	40.5	55.8	60.5	40.7	80.5	27.5	100.5	15.9	120.5	5.1
-39.0	144.0	-19.0	116.6	1.0	93.0	21.0	72.8	41.0	55.4	61.0	40.3	81.0	27.2	101.0	15.6	121.0	4.9
-38.5	143.3	-18.5	116.0	1.5	92.5	21.5	72.3	41.5	55.0	61.5	40.0	81.5	26.9	101.5	15.3	121.5	4.6
-38.0	142.6	-18.0	115.4	2.0	91.9	22.0	71.8	42.0	54.6	62.0	39.7	82.0	26.6	102.0	15.0	122.0	4.4
-37.5	141.8	-17.5	114.7	2.5	91.4	22.5	71.4	42.5	54.2	62.5	39.3	82.5	26.3	102.5	14.7	122.5	4.1
-37.0	141.1	-17.0	114.1	3.0	90.9	23.0	70.9	43.0	53.8	63.0	39.0	83.0	26.0	103.0	14.5	123.0	3.8
-36.5	140.4	-16.5	113.5	3.5	90.3	23.5	70.5	43.5	53.4	63.5	38.6	83.5	25.7	103.5	14.2	123.5	3.6
-36.0	139.7	-16.0	112.9	4.0	89.8	24.0	70.0	44.0	53.0	64.0	38.3	84.0	25.4	104.0	13.9	124.0	3.3
-35.5	138.9	-15.5	112.2	4.5	89.3	24.5	69.5	44.5	52.6	64.5	37.9	84.5	25.1	104.5	13.6	124.5	3.1
-35.0	138.2	-15.0	111.6	5.0	88.7	25.0	69.1	45.0	52.2	65.0	37.6	85.0	24.8	105.0	13.4	125.0	2.8
-34.5	137.5	-14.5	111.0	5.5	88.2	25.5	68.6	45.5	51.8	65.5	37.2	85.5	24.5	105.5	13.1		
-34.0	136.8	-14.0	110.4	6.0	87.7	26.0	68.2	46.0	51.4	66.0	36.9	86.0	24.2	106.0	12.8		
-33.5	136.1	-13.5	109.8	6.5	87.2	26.5	67.7	46.5	51.0	66.5	36.6	86.5	23.9	106.5	12.6		
-33.0	135.4	-13.0	109.2	7.0	86.6	27.0	67.3	47.0	50.6	67.0	36.2	87.0	23.6	107.0	12.3		
-32.5	134.7	-12.5	108.6	7.5	86.1	27.5	66.8	47.5	50.2	67.5	35.9	87.5	23.3	107.5	12.0		
-32.0	134.0	-12.0	108.0	8.0	85.6	28.0	66.4	48.0	49.9	68.0	35.6	88.0	23.0	108.0	11.7		
-31.5	133.3	-11.5	107.4	8.5	85.1	28.5	65.9	48.5	49.5	68.5	35.2	88.5	22.7	108.5	11.5		
-31.0	132.6	-11.0	106.8	9.0	84.6	29.0	65.5	49.0	49.1	69.0	34.9	89.0	22.4	109.0	11.2		
-30.5	131.9	-10.5	106.2	9.5	84.0	29.5	65.1	49.5	48.7	69.5	34.6	89.5	22.1	109.5	10.9		
-30.0	131.2	-10.0	105.6	10.0	83.5	30.0	64.6	50.0	48.3	70.0	34.2	90.0	21.8	110.0	10.7		
-29.5	130.5	-9.5	105.0	10.5	83.0	30.5	64.2	50.5	48.0	70.5	33.9	90.5	21.5	110.5	10.4		
-29.0	129.8	-9.0	104.4	11.0	82.5	31.0	63.7	51.0	47.6	71.0	33.6	91.0	21.3	111.0	10.1		
-28.5	129.1	-8.5	103.8	11.5	82.0	31.5	63.3	51.5	47.2	71.5	33.3	91.5	21.0	111.5	9.9		
-28.0	128.5	-8.0	103.2	12.0	81.5	32.0	62.9	52.0	46.8	72.0	32.9	92.0	20.7	112.0	9.6		
-27.5	127.8	-7.5	102.6	12.5	81.0	32.5	62.4	52.5	46.5	72.5	32.6	92.5	20.4	112.5	9.3		
-27.0	127.1	-7.0	102.0	13.0	80.5	33.0	62.0	53.0	46.1	73.0	32.3	93.0	20.1	113.0	9.1		
-26.5	126.4	-6.5	101.5	13.5	80.0	33.5	61.6	53.5	45.7	73.5	32.0	93.5	19.8	113.5	8.8		
-26.0	125.8	-6.0	100.9	14.0	79.5	34.0	61.2	54.0	45.4	74.0	31.6	94.0	19.5	114.0	8.5		
-25.5	125.1	-5.5	100.3	14.5	79.0	34.5	60.7	54.5	45.0	74.5	31.3	94.5	19.2	114.5	8.3		
-25.0	124.4	-5.0	99.7	15.0	78.5	35.0	60.3	55.0	44.6	75.0	31.0	95.0	19.0	115.0	8.0		
-24.5	123.8	-4.5	99.2	15.5	78.0	35.5	59.9	55.5	44.3	75.5	30.7	95.5	18.7	115.5	7.7		
-24.0	123.1	-4.0	98.6	16.0	77.6	36.0	59.5	56.0	43.9	76.0	30.4	96.0	18.4	116.0	7.5		
-23.5	122.4	-3.5	98.0	16.5	77.1	36.5	59.1	56.5	43.5	76.5	30.0	96.5	18.1	116.5	7.2		
-23.0	121.8	-3.0	97.5	17.0	76.6	37.0	58.6	57.0	43.2	77.0	29.7	97.0	17.8	117.0	7.0		
-22.5	121.1	-2.5	96.9	17.5	76.1	37.5	58.2	57.5	42.8	77.5	29.4	97.5	17.5	117.5	6.7		
-22.0	120.5	-2.0	96.4	18.0	75.6	38.0	57.8	58.0	42.5	78.0	29.1	98.0	17.2	118.0	6.4		
-21.5	119.8	-1.5	95.8	18.5	75.1	38.5	57.4	58.5	42.1	78.5	28.8	98.5	17.0	118.5	6.2		
-21.0	119.2	-1.0	95.2	19.0	74.7	39.0	57.0	59.0	41.8	79.0	28.5	99.0	16.7	119.0	5.9		
-20.5	118.5	-0.5	94.7	19.5	74.2	39.5	56.6	59.5	41.4	79.5	28.2	99.5	16.4	119.5	5.7		
-20.0	117.9	0.0	94.1	20.0	73.7	40.0	56.2	60.0	41.1	80.0	27.9	100.0	16.1	120.0	5.4		

**TABLE 4-3: T<sub>SET</sub> TO R<sub>SET</sub> CONVERSION TABLE FOR MCP9509/MCP9510C (COLD)**

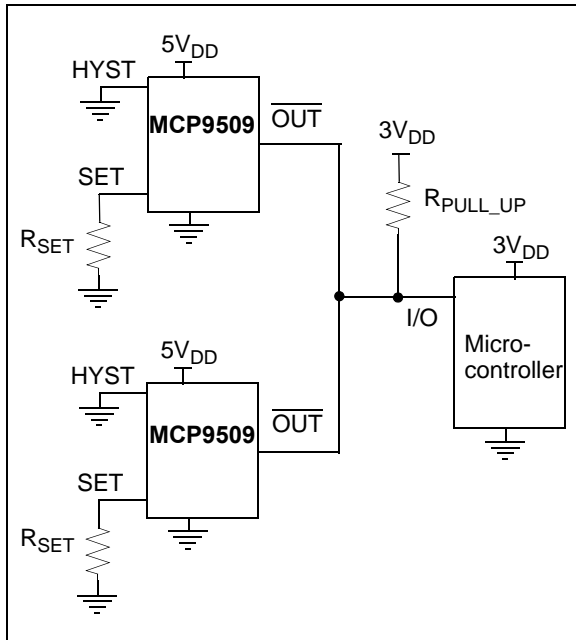
T <sub>SET</sub> (°C)	R <sub>SET</sub> (kΩ)	T <sub>SET</sub> (°C)	R <sub>SET</sub> (kΩ)	T <sub>SET</sub> (°C)	R <sub>SET</sub> (kΩ)	T <sub>SET</sub> (°C)	R <sub>SET</sub> (kΩ)	T <sub>SET</sub> (°C)	R <sub>SET</sub> (kΩ)	T <sub>SET</sub> (°C)	R <sub>SET</sub> (kΩ)	T <sub>SET</sub> (°C)	R <sub>SET</sub> (kΩ)	T <sub>SET</sub> (°C)	R <sub>SET</sub> (kΩ)	T <sub>SET</sub> (°C)	R <sub>SET</sub> (kΩ)
-40.0	146.3	-20.0	118.8	0.0	95.1	20.0	74.8	40.0	57.4	60.0	42.4	80.0	29.2	100.0	17.6	120.0	6.8
-39.5	145.6	-19.5	118.2	0.5	94.6	20.5	74.4	40.5	57.0	60.5	42.0	80.5	28.9	100.5	17.3	120.5	6.6
-39.0	144.8	-19.0	117.5	1.0	94.0	21.0	73.9	41.0	56.6	61.0	41.7	81.0	28.6	101.0	17.0	121.0	6.3
-38.5	144.1	-18.5	116.9	1.5	93.5	21.5	73.4	41.5	56.2	61.5	41.3	81.5	28.3	101.5	16.7	121.5	6.0
-38.0	143.4	-18.0	116.3	2.0	93.0	22.0	73.0	42.0	55.8	62.0	41.0	82.0	28.0	102.0	16.4	122.0	5.8
-37.5	142.6	-17.5	115.6	2.5	92.4	22.5	72.5	42.5	55.4	62.5	40.6	82.5	27.7	102.5	16.2	122.5	5.5
-37.0	141.9	-17.0	115.0	3.0	91.9	23.0	72.0	43.0	55.0	63.0	40.3	83.0	27.4	103.0	15.9	123.0	5.3
-36.5	141.2	-16.5	114.4	3.5	91.4	23.5	71.6	43.5	54.6	63.5	39.9	83.5	27.1	103.5	15.6	123.5	5.0
-36.0	140.5	-16.0	113.8	4.0	90.8	24.0	71.1	44.0	54.2	64.0	39.6	84.0	26.8	104.0	15.3	124.0	4.8
-35.5	139.8	-15.5	113.2	4.5	90.3	24.5	70.7	44.5	53.8	64.5	39.3	84.5	26.5	104.5	15.1	124.5	4.5
-35.0	139.0	-15.0	112.5	5.0	89.8	25.0	70.2	45.0	53.4	65.0	38.9	85.0	26.2	105.0	14.8	125.0	4.2
-34.5	138.3	-14.5	111.9	5.5	89.2	25.5	69.8	45.5	53.0	65.5	38.6	85.5	25.9	105.5	14.5		
-34.0	137.6	-14.0	111.3	6.0	88.7	26.0	69.3	46.0	52.7	66.0	38.2	86.0	25.6	106.0	14.3		
-33.5	136.9	-13.5	110.7	6.5	88.2	26.5	68.9	46.5	52.3	66.5	37.9	86.5	25.3	106.5	14.0		
-33.0	136.2	-13.0	110.1	7.0	87.7	27.0	68.4	47.0	51.9	67.0	37.6	87.0	25.0	107.0	13.7		
-32.5	135.5	-12.5	109.5	7.5	87.2	27.5	68.0	47.5	51.5	67.5	37.2	87.5	24.7	107.5	13.4		
-32.0	134.8	-12.0	108.9	8.0	86.6	28.0	67.5	48.0	51.1	68.0	36.9	88.0	24.4	108.0	13.2		
-31.5	134.1	-11.5	108.3	8.5	86.1	28.5	67.1	48.5	50.7	68.5	36.6	88.5	24.1	108.5	12.9		
-31.0	133.4	-11.0	107.7	9.0	85.6	29.0	66.7	49.0	50.4	69.0	36.2	89.0	23.8	109.0	12.6		
-30.5	132.7	-10.5	107.1	9.5	85.1	29.5	66.2	49.5	50.0	69.5	35.9	89.5	23.5	109.5	12.4		
-30.0	132.0	-10.0	106.5	10.0	84.6	30.0	65.8	50.0	49.6	70.0	35.6	90.0	23.2	110.0	12.1		
-29.5	131.4	-9.5	105.9	10.5	84.1	30.5	65.3	50.5	49.2	70.5	35.3	90.5	23.0	110.5	11.8		
-29.0	130.7	-9.0	105.3	11.0	83.6	31.0	64.9	51.0	48.9	71.0	34.9	91.0	22.7	111.0	11.6		
-28.5	130.0	-8.5	104.8	11.5	83.1	31.5	64.5	51.5	48.5	71.5	34.6	91.5	22.4	111.5	11.3		
-28.0	129.3	-8.0	104.2	12.0	82.6	32.0	64.1	52.0	48.1	72.0	34.3	92.0	22.1	112.0	11.0		
-27.5	128.6	-7.5	103.6	12.5	82.1	32.5	63.6	52.5	47.7	72.5	34.0	92.5	21.8	112.5	10.8		
-27.0	128.0	-7.0	103.0	13.0	81.6	33.0	63.2	53.0	47.4	73.0	33.6	93.0	21.5	113.0	10.5		
-26.5	127.3	-6.5	102.4	13.5	81.1	33.5	62.8	53.5	47.0	73.5	33.3	93.5	21.2	113.5	10.2		
-26.0	126.6	-6.0	101.9	14.0	80.6	34.0	62.4	54.0	46.6	74.0	33.0	94.0	20.9	114.0	10.0		
-25.5	126.0	-5.5	101.3	14.5	80.1	34.5	61.9	54.5	46.3	74.5	32.7	94.5	20.7	114.5	9.7		
-25.0	125.3	-5.0	100.7	15.0	79.6	35.0	61.5	55.0	45.9	75.0	32.4	95.0	20.4	115.0	9.4		
-24.5	124.6	-4.5	100.1	15.5	79.1	35.5	61.1	55.5	45.6	75.5	32.0	95.5	20.1	115.5	9.2		
-24.0	124.0	-4.0	99.6	16.0	78.6	36.0	60.7	56.0	45.2	76.0	31.7	96.0	19.8	116.0	8.9		
-23.5	123.3	-3.5	99.0	16.5	78.2	36.5	60.3	56.5	44.8	76.5	31.4	96.5	19.5	116.5	8.7		
-23.0	122.7	-3.0	98.5	17.0	77.7	37.0	59.8	57.0	44.5	77.0	31.1	97.0	19.2	117.0	8.4		
-22.5	122.0	-2.5	97.9	17.5	77.2	37.5	59.4	57.5	44.1	77.5	30.8	97.5	19.0	117.5	8.1		
-22.0	121.4	-2.0	97.3	18.0	76.7	38.0	59.0	58.0	43.8	78.0	30.5	98.0	18.7	118.0	7.9		
-21.5	120.7	-1.5	96.8	18.5	76.2	38.5	58.6	58.5	43.4	78.5	30.2	98.5	18.4	118.5	7.6		
-21.0	120.1	-1.0	96.2	19.0	75.8	39.0	58.2	59.0	43.1	79.0	29.9	99.0	18.1	119.0	7.3		
-20.5	119.4	-0.5	95.7	19.5	75.3	39.5	57.8	59.5	42.7	79.5	29.5	99.5	17.8	119.5	7.1		
-20.0	118.8	0.0	95.1	20.0	74.8	40.0	57.4	60.0	42.4	80.0	29.2	100.0	17.6	120.0	6.8		

# MCP9509/10

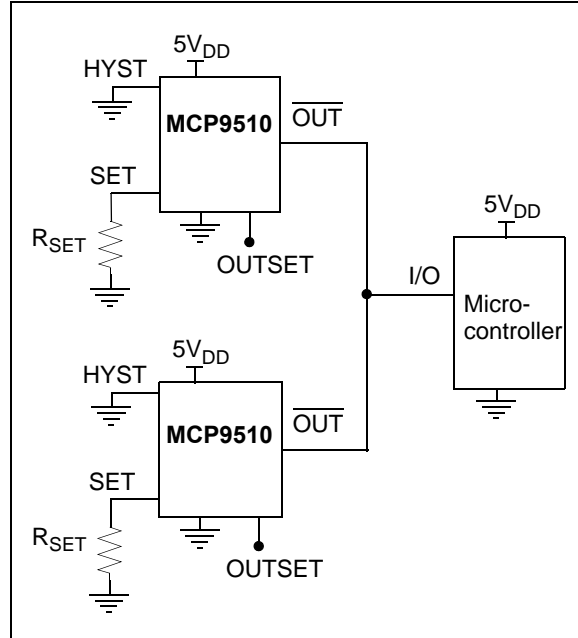
## 4.6 Application Information

The MCP9509/10 temperature switch integrates a temperature sensor and a comparator circuit which outputs an alert signal when the user programmed temperature threshold is exceeded. The external resistor value to set the output threshold can be determined using [Table 4-2](#). A constant current source  $I_{SET} = 5 \mu A$  (typical) biases the external resistor  $R_{SET}$ . A thermal diode is used to measure ambient temperature. When the voltage across the thermal diode exceeds the voltage across  $R_{SET}$ ,  $V_{SET}$ , the sensor output asserts. The sensor output de-asserts when the diode voltage drops below  $V_{SET}$  and the user selected hysteresis level.

The MCP9509/10 provide Open-drain output where multiple sensors from multiple PCB hot-spots can be connected to a single processor I/O input with a wired-Or Configuration. The MCP9509 requires an external pull-up resistor which can be used to level-shift the alert signal. For example, if the sensors are powered with  $5V_{DD}$  and the controller or processor is powered with  $3V_{DD}$ , the external resistor can be level-shifted by connecting  $3V_{DD}$  to the pull-up resistor as shown in [Figure 4-5](#). The MCP9510 eliminates the need for an external resistor while providing wired-Or function ([Figure 4-6](#)). The MCP9510 also provides push-pull output configuration for a direct connection to the processor with Active-Low or Active-High assert polarities.



**FIGURE 4-5:** MCP9509 Wired-Or Output Configuration with Level-shift.



**FIGURE 4-6:** MCP9510 Wired-Or Output Configuration with Internal Pull-up Resistor.

### 4.6.1 LAYOUT CONSIDERATION AND THERMAL CONSIDERATION

This family of sensors measure temperature by monitoring the voltage level of a thermal diode located in the die. A low-impedance thermal path between the die and the PCB is provided by the pins. Therefore, the sensor effectively monitors PCB temperature. For efficient performance, it is recommended to layout the device as close to the heat source as possible. It is also recommended to use a de-coupling capacitor of  $0.1 \mu F$  to  $1 \mu F$  between  $V_{DD}$  and GND pins for stability.

When connecting an external resistor to the MCP9509 device, the current through the pull-up resistor must be considered to prevent self-heat due to power. This can be determined using [Equation 4-3](#).

#### EQUATION 4-3: EFFECT OF SELF-HEATING

$$T_J - T_A = \theta_{JA} (V_{DD} \times I_{DD} + V_{OL} \times I_{OUT})$$

Where:

$T_J$	=	Junction Temperature
$T_A$	=	Ambient Temperature
$\theta_{JA}$	=	Package Thermal Resistance ( $220.7 \text{ }^\circ\text{C/W}$ )
$V_{OL}$	=	Sensor Output Low Voltage
$I_{OUT}$	=	Output Current

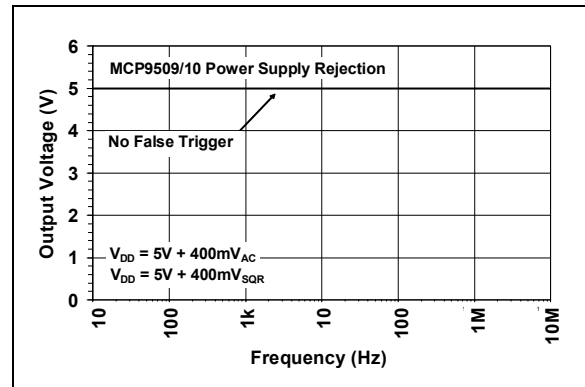
For example, at room temperature, when output asserts Active-Low and maximum  $I_{DD} = 50 \mu\text{A}$ ,  $V_{DD} = 5.5\text{V}$ ,  $V_{OL} = 0.3\text{V}$  and  $I_{OUT} = 5 \text{mA}$  (see specification table), the self heating due to power dissipation ( $T_J - T_A$ ) is  $\sim 0.4^\circ\text{C}$ .

## 4.6.2 DRIVING OUTSET WITH A MICROCONTROLLER I/O PIN

The OUTSET pin can be controlled using a Microcontroller input/output (I/O) pin. I/O levels HIGH and LOW provide push-pull configuration with Active-High and Active-Low outputs, respectively. The Open-Drain output with internal pull-up resistor can be selected by configuring the I/O pin as a High-Impedance Input. The Open-Drain output can also be selected by forcing voltage level  $V_{OSET}$  from a low impedance source. With this configuration, there may be some leakage current due to impedance mismatch, (See Figure 4-2).

## 4.6.3 POWER SUPPLY REJECTION

The MCP9509/10 family of sensors are designed to prevent false output trigger due to high frequency power supply or system noise. Figure 4-7 shows device performance with a high frequency signal added on  $V_{DD}$ . The output is not triggered due to the signal added on  $V_{DD}$ . With some applications, it is recommended to add a bypass capacitor of  $0.1 \mu\text{F}$  to  $1 \mu\text{F}$ .



**FIGURE 4-7:** Power Supply Rejection (PSR).

# MCP9509/10

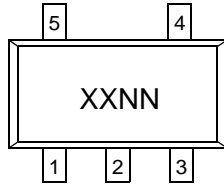
---

NOTES:

## 5.0 PACKAGING INFORMATION

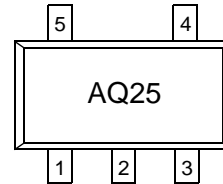
### 5.1 Package Marking Information

5-Lead SOT-23

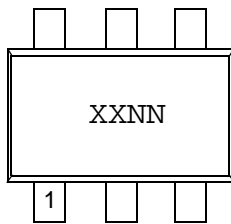


Device	Code
MCP9509CT-E/OT	AQNN
MCP9509HT-E/OT	BPNN

Example:

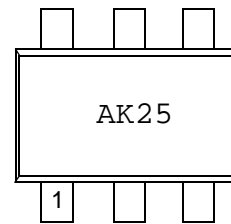


6-Lead SOT-23



Part Number	Code
MCP9510CT-E/CH	AKNN
MCP9510HT-E/CH	ALNN

Example



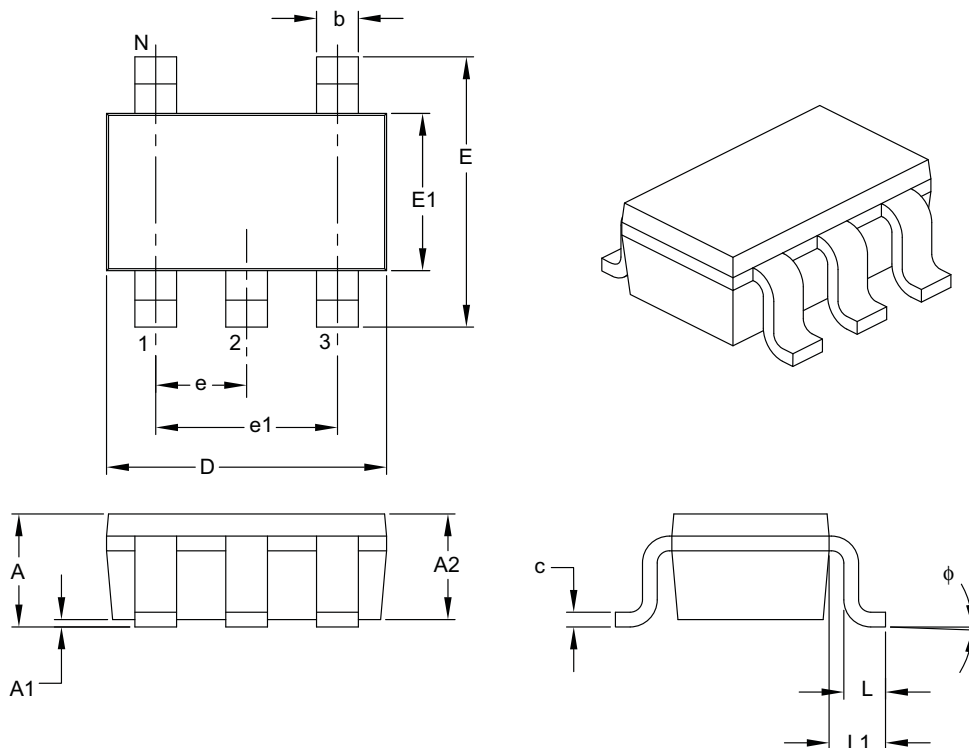
<b>Legend:</b>	XX...X	Customer-specific information
	Y	Year code (last digit of calendar year)
	YY	Year code (last 2 digits of calendar year)
	WW	Week code (week of January 1 is week '01')
	NNN	Alphanumeric traceability code
	(e3)	Pb-free JEDEC designator for Matte Tin (Sn)
	*	This package is Pb-free. The Pb-free JEDEC designator (e3) can be found on the outer packaging for this package.

**Note:** In the event the full Microchip part number cannot be marked on one line, it will be carried over to the next line, thus limiting the number of available characters for customer-specific information.

# MCP9509/10

## 5-Lead Plastic Small Outline Transistor (OT) [SOT-23]

**Note:** For the most current package drawings, please see the Microchip Packaging Specification located at <http://www.microchip.com/packaging>



Dimension Limits	Units	MILLIMETERS		
		MIN	NOM	MAX
Number of Pins	N	5		
Lead Pitch	e	0.95 BSC		
Outside Lead Pitch	e1	1.90 BSC		
Overall Height	A	0.90	–	1.45
Molded Package Thickness	A2	0.89	–	1.30
Standoff	A1	0.00	–	0.15
Overall Width	E	2.20	–	3.20
Molded Package Width	E1	1.30	–	1.80
Overall Length	D	2.70	–	3.10
Foot Length	L	0.10	–	0.60
Footprint	L1	0.35	–	0.80
Foot Angle	$\phi$	0°	–	30°
Lead Thickness	c	0.08	–	0.26
Lead Width	b	0.20	–	0.51

**Notes:**

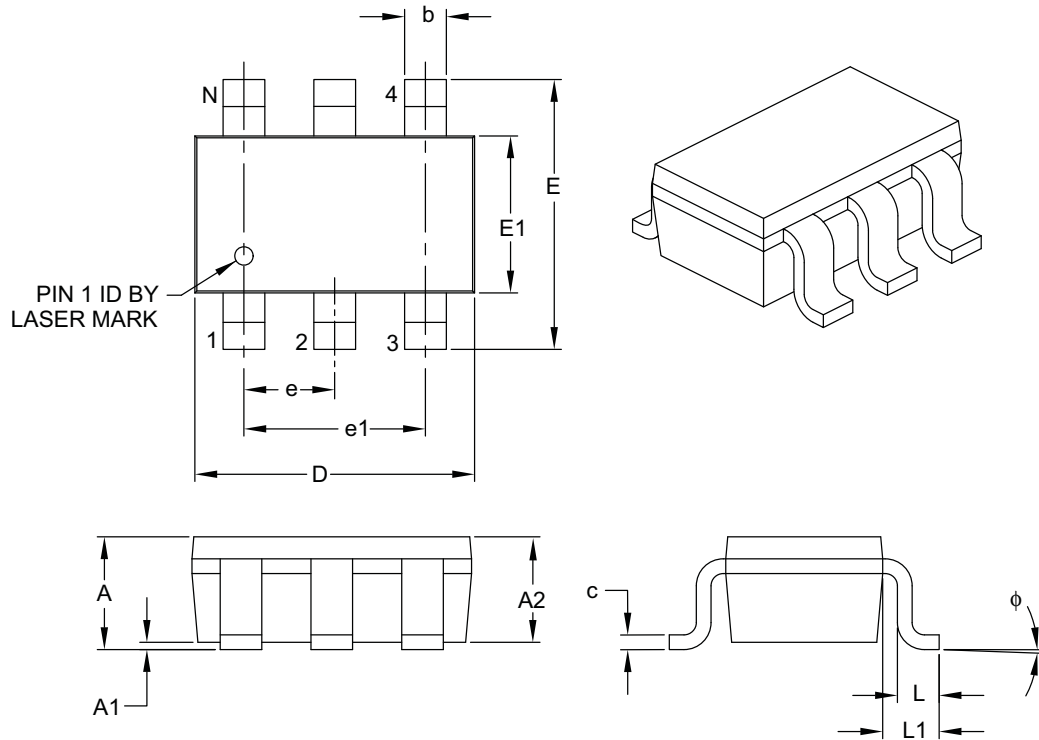
- Dimensions D and E1 do not include mold flash or protrusions. Mold flash or protrusions shall not exceed 0.127 mm per side.
- Dimensioning and tolerancing per ASME Y14.5M.

BSC: Basic Dimension. Theoretically exact value shown without tolerances.

Microchip Technology Drawing C04-091B

## 6-Lead Plastic Small Outline Transistor (CH) [SOT-23]

**Note:** For the most current package drawings, please see the Microchip Packaging Specification located at <http://www.microchip.com/packaging>



Dimension Limits	Units	MILLIMETERS		
		MIN	NOM	MAX
Number of Pins	N	6		
Pitch	e	0.95 BSC		
Outside Lead Pitch	e1	1.90 BSC		
Overall Height	A	0.90	–	1.45
Molded Package Thickness	A2	0.89	–	1.30
Standoff	A1	0.00	–	0.15
Overall Width	E	2.20	–	3.20
Molded Package Width	E1	1.30	–	1.80
Overall Length	D	2.70	–	3.10
Foot Length	L	0.10	–	0.60
Footprint	L1	0.35	–	0.80
Foot Angle	$\phi$	0°	–	30°
Lead Thickness	c	0.08	–	0.26
Lead Width	b	0.20	–	0.51

**Notes:**

- Dimensions D and E1 do not include mold flash or protrusions. Mold flash or protrusions shall not exceed 0.127 mm per side.
- Dimensioning and tolerancing per ASME Y14.5M.

BSC: Basic Dimension. Theoretically exact value shown without tolerances.

Microchip Technology Drawing C04-028B

# MCP9509/10

---

NOTES:

## APPENDIX A: REVISION HISTORY

### Revision A (November 2008)

- Original Release of this Document.

# MCP9509/10

---

NOTES:

## PRODUCT IDENTIFICATION SYSTEM

To order or obtain information, e.g., on pricing or delivery, refer to the factory or the listed sales office.

<u>PART NO.</u>	<u>-X</u>	<u>/XX</u>
Device	Temperature Range	Package
Device:	MCP9509H: Resistor Programmable Temperature Switch, Hot Option	
	MCP9509C: Resistor Programmable Temperature Switch, Cold Option	
	MCP9510H: Resistor Programmable Temperature Switch, Hot Option	
	MCP9510C: Resistor Programmable Temperature Switch, Cold Option	
Temperature Range:	E = -40°C to +125°C	
Package:	CH = Plastic Small Outline Transistor (SOT-23), 6-lead (MCP9510 only)	
	OT = Plastic Small Outline Transistor (SOT-23), 5-lead (MCP9509)	

**Examples:**

a) MCP9509CT-E/OT: Cold option, Extended Temp., 5LD SOT-23 package.

b) MCP9509HT-E/OT: Hot option, Extended Temp., 5LD SOT-23 package.

a) MCP9510C-E/CH: Cold option, Extended Temp., 6LD SOT-23 package.

b) MCP9510H-E/CH: Hot option, Extended Temp., 6LD SOT-23 package.

# MCP9509/10

---

NOTES:

---

**Note the following details of the code protection feature on Microchip devices:**

- Microchip products meet the specification contained in their particular Microchip Data Sheet.
- Microchip believes that its family of products is one of the most secure families of its kind on the market today, when used in the intended manner and under normal conditions.
- There are dishonest and possibly illegal methods used to breach the code protection feature. All of these methods, to our knowledge, require using the Microchip products in a manner outside the operating specifications contained in Microchip's Data Sheets. Most likely, the person doing so is engaged in theft of intellectual property.
- Microchip is willing to work with the customer who is concerned about the integrity of their code.
- Neither Microchip nor any other semiconductor manufacturer can guarantee the security of their code. Code protection does not mean that we are guaranteeing the product as “unbreakable.”

Code protection is constantly evolving. We at Microchip are committed to continuously improving the code protection features of our products. Attempts to break Microchip's code protection feature may be a violation of the Digital Millennium Copyright Act. If such acts allow unauthorized access to your software or other copyrighted work, you may have a right to sue for relief under that Act.

---

Information contained in this publication regarding device applications and the like is provided only for your convenience and may be superseded by updates. It is your responsibility to ensure that your application meets with your specifications. MICROCHIP MAKES NO REPRESENTATIONS OR WARRANTIES OF ANY KIND WHETHER EXPRESS OR IMPLIED, WRITTEN OR ORAL, STATUTORY OR OTHERWISE, RELATED TO THE INFORMATION, INCLUDING BUT NOT LIMITED TO ITS CONDITION, QUALITY, PERFORMANCE, MERCHANTABILITY OR FITNESS FOR PURPOSE. Microchip disclaims all liability arising from this information and its use. Use of Microchip devices in life support and/or safety applications is entirely at the buyer's risk, and the buyer agrees to defend, indemnify and hold harmless Microchip from any and all damages, claims, suits, or expenses resulting from such use. No licenses are conveyed, implicitly or otherwise, under any Microchip intellectual property rights.

**Trademarks**

The Microchip name and logo, the Microchip logo, Accuron, dsPIC, KEELOQ, KEELOQ logo, MPLAB, PIC, PICmicro, PICSTART, rfPIC, SmartShunt and UNI/O are registered trademarks of Microchip Technology Incorporated in the U.S.A. and other countries.


FilterLab, Linear Active Thermistor, MXDEV, MXLAB, SEEVAL, SmartSensor and The Embedded Control Solutions Company are registered trademarks of Microchip Technology Incorporated in the U.S.A.

Analog-for-the-Digital Age, Application Maestro, CodeGuard, dsPICDEM, dsPICDEM.net, dsPICworks, dsSPEAK, ECAN, ECONOMONITOR, FanSense, In-Circuit Serial Programming, ICSP, ICEPIC, Mindi, MiWi, MPASM, MPLAB Certified logo, MPLIB, MPLINK, mTouch, PICkit, PICDEM, PICDEM.net, PICtail, PIC<sup>32</sup> logo, PowerCal, PowerInfo, PowerMate, PowerTool, REAL ICE, rfLAB, Select Mode, Total Endurance, WiperLock and ZENA are trademarks of Microchip Technology Incorporated in the U.S.A. and other countries.

SQTP is a service mark of Microchip Technology Incorporated in the U.S.A.

All other trademarks mentioned herein are property of their respective companies.

© 2008, Microchip Technology Incorporated, Printed in the U.S.A., All Rights Reserved.

 Printed on recycled paper.

**QUALITY MANAGEMENT SYSTEM**  
**CERTIFIED BY DNV**  
**== ISO/TS 16949:2002 ==**

*Microchip received ISO/TS-16949:2002 certification for its worldwide headquarters, design and wafer fabrication facilities in Chandler and Tempe, Arizona; Gresham, Oregon and design centers in California and India. The Company's quality system processes and procedures are for its PIC® MCUs and dsPIC® DSCs, KEELOQ® code hopping devices, Serial EEPROMs, microperipherals, nonvolatile memory and analog products. In addition, Microchip's quality system for the design and manufacture of development systems is ISO 9001:2000 certified.*



## WORLDWIDE SALES AND SERVICE

### AMERICAS

**Corporate Office**  
2355 West Chandler Blvd.  
Chandler, AZ 85224-6199  
Tel: 480-792-7200  
Fax: 480-792-7277  
Technical Support:  
<http://support.microchip.com>  
Web Address:  
[www.microchip.com](http://www.microchip.com)

**Atlanta**  
Duluth, GA  
Tel: 678-957-9614  
Fax: 678-957-1455

**Boston**  
Westborough, MA  
Tel: 774-760-0087  
Fax: 774-760-0088

**Chicago**  
Itasca, IL  
Tel: 630-285-0071  
Fax: 630-285-0075

**Dallas**  
Addison, TX  
Tel: 972-818-7423  
Fax: 972-818-2924

**Detroit**  
Farmington Hills, MI  
Tel: 248-538-2250  
Fax: 248-538-2260

**Kokomo**  
Kokomo, IN  
Tel: 765-864-8360  
Fax: 765-864-8387

**Los Angeles**  
Mission Viejo, CA  
Tel: 949-462-9523  
Fax: 949-462-9608

**Santa Clara**  
Santa Clara, CA  
Tel: 408-961-6444  
Fax: 408-961-6445

**Toronto**  
Mississauga, Ontario,  
Canada  
Tel: 905-673-0699  
Fax: 905-673-6509

### ASIA/PACIFIC

**Asia Pacific Office**  
Suites 3707-14, 37th Floor  
Tower 6, The Gateway  
Harbour City, Kowloon  
Hong Kong  
Tel: 852-2401-1200  
Fax: 852-2401-3431

**Australia - Sydney**  
Tel: 61-2-9868-6733  
Fax: 61-2-9868-6755

**China - Beijing**  
Tel: 86-10-8528-2100  
Fax: 86-10-8528-2104

**China - Chengdu**  
Tel: 86-28-8665-5511  
Fax: 86-28-8665-7889

**China - Hong Kong SAR**  
Tel: 852-2401-1200  
Fax: 852-2401-3431

**China - Nanjing**  
Tel: 86-25-8473-2460  
Fax: 86-25-8473-2470

**China - Qingdao**  
Tel: 86-532-8502-7355  
Fax: 86-532-8502-7205

**China - Shanghai**  
Tel: 86-21-5407-5533  
Fax: 86-21-5407-5066

**China - Shenyang**  
Tel: 86-24-2334-2829  
Fax: 86-24-2334-2393

**China - Shenzhen**  
Tel: 86-755-8203-2660  
Fax: 86-755-8203-1760

**China - Wuhan**  
Tel: 86-27-5980-5300  
Fax: 86-27-5980-5118

**China - Xiamen**  
Tel: 86-592-2388138  
Fax: 86-592-2388130

**China - Xian**  
Tel: 86-29-8833-7252  
Fax: 86-29-8833-7256

**China - Zhuhai**  
Tel: 86-756-3210040  
Fax: 86-756-3210049

### ASIA/PACIFIC

**India - Bangalore**  
Tel: 91-80-4182-8400  
Fax: 91-80-4182-8422

**India - New Delhi**  
Tel: 91-11-4160-8631  
Fax: 91-11-4160-8632

**India - Pune**  
Tel: 91-20-2566-1512  
Fax: 91-20-2566-1513

**Japan - Yokohama**  
Tel: 81-45-471- 6166  
Fax: 81-45-471-6122

**Korea - Daegu**  
Tel: 82-53-744-4301  
Fax: 82-53-744-4302

**Korea - Seoul**  
Tel: 82-2-554-7200  
Fax: 82-2-558-5932 or  
82-2-558-5934

**Malaysia - Kuala Lumpur**  
Tel: 60-3-6201-9857  
Fax: 60-3-6201-9859

**Malaysia - Penang**  
Tel: 60-4-227-8870  
Fax: 60-4-227-4068

**Philippines - Manila**  
Tel: 63-2-634-9065  
Fax: 63-2-634-9069

**Singapore**  
Tel: 65-6334-8870  
Fax: 65-6334-8850

**Taiwan - Hsin Chu**  
Tel: 886-3-572-9526  
Fax: 886-3-572-6459

**Taiwan - Kaohsiung**  
Tel: 886-7-536-4818  
Fax: 886-7-536-4803

**Taiwan - Taipei**  
Tel: 886-2-2500-6610  
Fax: 886-2-2508-0102

**Thailand - Bangkok**  
Tel: 66-2-694-1351  
Fax: 66-2-694-1350

### EUROPE

**Austria - Wels**  
Tel: 43-7242-2244-39  
Fax: 43-7242-2244-393

**Denmark - Copenhagen**  
Tel: 45-4450-2828  
Fax: 45-4485-2829

**France - Paris**  
Tel: 33-1-69-53-63-20  
Fax: 33-1-69-30-90-79

**Germany - Munich**  
Tel: 49-89-627-144-0  
Fax: 49-89-627-144-44

**Italy - Milan**  
Tel: 39-0331-742611  
Fax: 39-0331-466781



**Netherlands - Drunen**  
Tel: 31-416-690399  
Fax: 31-416-690340

**Spain - Madrid**  
Tel: 34-91-708-08-90  
Fax: 34-91-708-08-91






**UK - Wokingham**  
Tel: 44-118-921-5869  
Fax: 44-118-921-5820

## Looking for pricing, stock, or lifecycle information?

Click below to explore more details on WIN SOURCE:

-  [View MCP9509HT-E/OT on WIN SOURCE](#)
-  [Microchip Technology](#) Information

## Optimize Your Supply Chain with WIN SOURCE Solutions

-  Global Sourcing Solution
-  Obsolete Management
-  Cost Control Management
-  Shortage Management
-  Alternative Solution
-  Excess Inventory Management