

2.5V to 6.0V Micropower CMOS Op Amp

Features

- Low Input Offset Voltage: 250 μ V (maximum)
- Rail-to-Rail Output
- Low Input Bias Current: 80 pA (maximum at +85°C)
- Low Quiescent Current: 25 μ A (maximum)
- Power Supply Voltage: 2.5V to 6.0V
- Unity-Gain Stable
- Chip Select (\overline{CS}) Capability: **MCP608**
- Industrial Temperature Range: -40°C to +85°C
- No Phase Reversal
- Available in Single, Dual and Quad Packages

Typical Applications

- Battery Power Instruments
- High-Impedance Applications
- Strain Gauges
- Medical Instruments
- Test Equipment

Design Aids

- SPICE Macro Models
- FilterLab[®] Software
- Mindi[™] Circuit Designer & Simulator
- Analog Demonstration and Evaluation Boards
- Application Notes

Typical Application

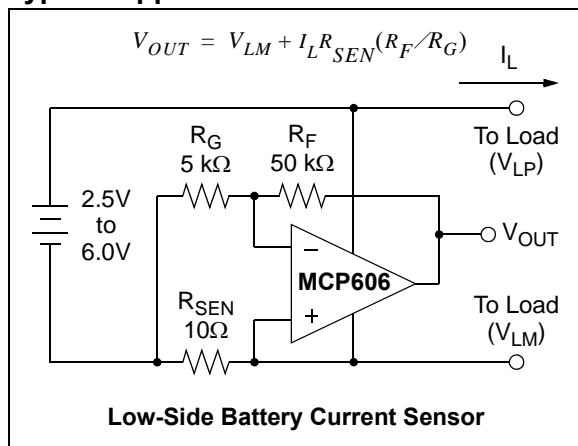

Description

The MCP606/7/8/9 family of operational amplifiers (op amps) from Microchip Technology Inc. are unity-gain stable with low offset voltage (250 μ V, maximum). Performance characteristics include rail-to-rail output swing capability and low input bias current (80 pA at +85°C, maximum). These features make this family of op amps well suited for single-supply, precision, high-impedance, battery-powered applications.

The single is available in standard 8-lead PDIP, SOIC and TSSOP packages, as well as in a SOT-23-5 package. The single MCP608 with Chip Select (\overline{CS}) is offered in the standard 8-lead PDIP, SOIC and TSSOP packages. The dual MCP607 is offered in the standard 8-lead PDIP, SOIC and TSSOP packages. Finally, the quad MCP609 is offered in the standard 14-lead PDIP, SOIC and TSSOP packages. All devices are fully specified from -40°C to +85°C, with power supplies from 2.5V to 6.0V.

Package Types

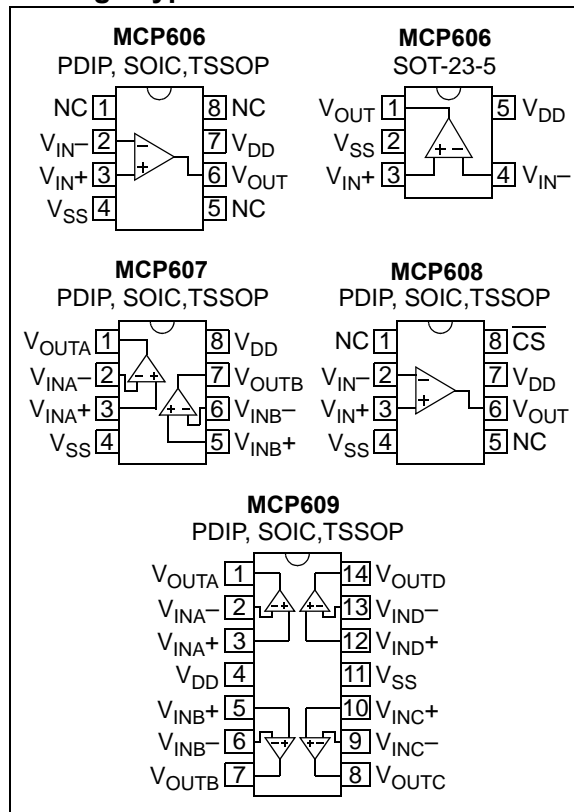

MCP606/7/8/9

NOTES:

1.0 ELECTRICAL CHARACTERISTICS

Absolute Maximum Ratings †

$V_{DD} - V_{SS}$	7.0V
Current at Input Pins	± 2 mA
Analog Inputs (V_{IN+} , V_{IN-}) ††	$V_{SS} - 1.0V$ to $V_{DD} + 1.0V$
All Other Inputs and Outputs	$V_{SS} - 0.3V$ to $V_{DD} + 0.3V$
Difference Input Voltage	$ V_{DD} - V_{SS} $
Output Short Circuit Current	Continuous
Current at Output and Supply Pins	± 30 mA
Storage Temperature	-65° C to $+150^{\circ}$ C
Maximum Junction Temperature (T_J)	$+150^{\circ}$ C
ESD Protection On All Pins (HBM; MM)	≥ 3 kV; 200V

† **Notice:** Stresses above those listed under “Absolute Maximum Ratings” may cause permanent damage to the device. This is a stress rating only and functional operation of the device at those or any other conditions above those indicated in the operational listings of this specification is not implied. Exposure to maximum rating conditions for extended periods may affect device reliability.

†† See Section 4.1.2 “Input Voltage and Current Limits”.

DC CHARACTERISTICS

Electrical Characteristics: Unless otherwise indicated, $V_{DD} = +2.5V$ to $+5.5V$, $V_{SS} = GND$, $T_A = +25^{\circ}C$, $V_{CM} = V_{DD}/2$, $V_{OUT} \approx V_{DD}/2$, $V_L = V_{DD}/2$, $R_L = 100$ k Ω to V_L , and CS is tied low (refer to Figure 1-2 and Figure 1-3).

Parameters	Sym	Min	Typ	Max	Units	Conditions
Input Offset						
Input Offset Voltage	V_{OS}	-250	—	+250	μ V	
Input Offset Drift with Temperature	$\Delta V_{OS}/\Delta T_A$	—	± 1.8	—	μ V/ $^{\circ}$ C	$T_A = -40^{\circ}C$ to $+85^{\circ}C$
Power Supply Rejection Ratio	PSRR	80	93	—	dB	
Input Bias Current and Impedance						
Input Bias Current	I_B	—	1	—	pA	
At Temperature	I_B	—	—	80	pA	$T_A = +85^{\circ}C$
Input Offset Bias Current	I_{OS}	—	1	—	pA	
Common Mode Input Impedance	Z_{CM}	—	$10^{13} 6$	—	ΩpF	
Differential Input Impedance	Z_{DIFF}	—	$10^{13} 6$	—	ΩpF	
Common Mode						
Common Mode Input Range	V_{CMR}	$V_{SS} - 0.3$		$V_{DD} - 1.1$	V	CMRR ≥ 75 dB
Common Mode Rejection Ratio	CMRR	75	91	—	dB	$V_{DD} = 5V$, $V_{CM} = -0.3V$ to $3.9V$
Open-Loop Gain						
DC Open-Loop Gain (Large-signal)	A_{OL}	105	121	—	dB	$R_L = 25$ k Ω to V_L , $V_{OUT} = 50$ mV to $V_{DD} - 50$ mV
DC Open-Loop Gain (Large-signal)	A_{OL}	100	118	—	dB	$R_L = 5$ k Ω to V_L , $V_{OUT} = 0.1V$ to $V_{DD} - 0.1V$
Output						
Maximum Output Voltage Swing	V_{OL}, V_{OH}	$V_{SS} + 15$	—	$V_{DD} - 20$	mV	$R_L = 25$ k Ω to V_L , 0.5V input overdrive
	V_{OL}, V_{OH}	$V_{SS} + 45$	—	$V_{DD} - 60$	mV	$R_L = 5$ k Ω to V_L , 0.5V input overdrive
Linear Output Voltage Range	V_{OUT}	$V_{SS} + 50$	—	$V_{DD} - 50$	mV	$R_L = 25$ k Ω to V_L , $A_{OL} \geq 105$ dB
	V_{OUT}	$V_{SS} + 100$	—	$V_{DD} - 100$	mV	$R_L = 5$ k Ω to V_L , $A_{OL} \geq 100$ dB
Output Short Circuit Current	I_{SC}	—	7	—	mA	$V_{DD} = 2.5V$
	I_{SC}	—	17	—	mA	$V_{DD} = 5.5V$
Power Supply						
Supply Voltage	V_{DD}	2.5	—	6.0	V	
Quiescent Current per Amplifier	I_Q	—	18.7	25	μ A	$I_O = 0$

Note 1: All parts with date codes November 2007 and later have been screened to ensure operation at $V_{DD} = 6.0V$. However, the other minimum and maximum specifications are measured at 2.5V and 5.5V.

MCP606/7/8/9

AC CHARACTERISTICS

Electrical Characteristics: Unless otherwise indicated, $V_{DD} = +2.5V$ to $+5.5V$, $V_{SS} = GND$, $T_A = +25^\circ C$, $V_{CM} = V_{DD}/2$, $V_{OUT} \approx V_{DD}/2$, $V_L = V_{DD}/2$, $R_L = 100\text{ k}\Omega$ to V_L and $C_L = 60\text{ pF}$, and \overline{CS} is tied low (refer to [Figure 1-2](#) and [Figure 1-3](#)).

Parameters	Sym	Min	Typ	Max	Units	Conditions
AC Response						
Gain Bandwidth Product	GBWP	—	155	—	kHz	
Phase Margin	PM	—	62	—	°	$G = +1\text{ V/V}$
Slew Rate	SR	—	0.08	—	V/ μs	
Noise						
Input Noise Voltage	E_{ni}	—	2.8	—	μV_{p-p}	$f = 0.1\text{ Hz to }10\text{ Hz}$
Input Noise Voltage Density	e_{ni}	—	38	—	nV/ \sqrt{Hz}	$f = 1\text{ kHz}$
Input Noise Current Density	i_{ni}	—	3	—	fA/ \sqrt{Hz}	$f = 1\text{ kHz}$

MCP608 CHIP SELECT CHARACTERISTICS

Electrical Characteristics: Unless otherwise indicated, $V_{DD} = +2.5V$ to $+5.5V$, $V_{SS} = GND$, $T_A = +25^\circ C$, $V_{CM} = V_{DD}/2$, $V_{OUT} \approx V_{DD}/2$, $V_L = V_{DD}/2$, $R_L = 100\text{ k}\Omega$ to V_L and $C_L = 60\text{ pF}$, and \overline{CS} is tied low (refer to [Figure 1-2](#) and [Figure 1-3](#)).

Parameters	Sym	Min	Typ	Max	Units	Conditions
\overline{CS} Low Specifications						
\overline{CS} Logic Threshold, Low	V_{IL}	V_{SS}	—	$0.2 V_{DD}$	V	
\overline{CS} Input Current, Low	I_{CSL}	-0.1	0.01	—	μA	$\overline{CS} = 0.2V_{DD}$
\overline{CS} High Specifications						
\overline{CS} Logic Threshold, High	V_{IH}	$0.8 V_{DD}$	—	V_{DD}	V	
\overline{CS} Input Current, High	I_{CSH}	—	0.01	0.1	μA	$\overline{CS} = V_{DD}$
\overline{CS} Input High, GND Current	I_{SS}	-2	-0.05	—	μA	$\overline{CS} = V_{DD}$
Amplifier Output Leakage, \overline{CS} High	$I_{O(LEAK)}$	—	10	—	nA	$\overline{CS} = V_{DD}$
\overline{CS} Dynamic Specifications						
\overline{CS} Low to Amplifier Output Turn-on Time	t_{ON}	—	9	100	μs	$\overline{CS} = 0.2V_{DD}$ to $V_{OUT} = 0.9 V_{DD}/2$, $G = +1\text{ V/V}$, $R_L = 1\text{ k}\Omega$ to V_{SS}
\overline{CS} High to Amplifier Output Hi-Z	t_{OFF}	—	0.1	—	μs	$\overline{CS} = 0.8V_{DD}$ to $V_{OUT} = 0.1 V_{DD}/2$, $G = +1\text{ V/V}$, $R_L = 1\text{ k}\Omega$ to V_{SS}
\overline{CS} Hysteresis	V_{HYST}	—	0.6	—	V	$V_{DD} = 5.0V$

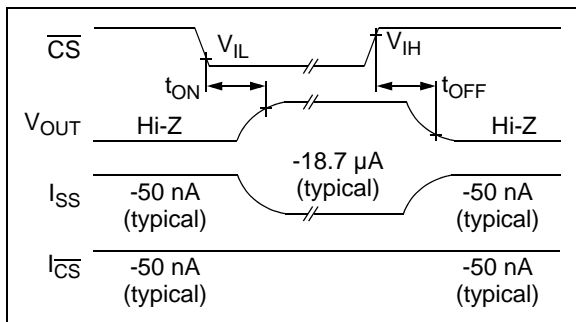

FIGURE 1-1: Timing Diagram for the \overline{CS} Pin on the MCP608.

TEMPERATURE CHARACTERISTICS

Electrical Characteristics: Unless otherwise indicated, $V_{DD} = +2.5V$ to $+5.5V$ and $V_{SS} = GND$.						
Parameters	Sym	Min	Typ	Max	Units	Conditions
Temperature Ranges						
Specified Temperature Range	T_A	-40	—	+85	°C	
Operating Temperature Range	T_A	-40	—	+125	°C	Note 1
Storage Temperature Range	T_A	-65	—	+150	°C	
Thermal Package Resistances						
Thermal Resistance, 5L-SOT23	θ_{JA}	—	220.7	—	°C/W	
Thermal Resistance, 8L-PDIP	θ_{JA}	—	89.3	—	°C/W	
Thermal Resistance, 8L-SOIC	θ_{JA}	—	149.5	—	°C/W	
Thermal Resistance, 8L-TSSOP	θ_{JA}	—	139	—	°C/W	
Thermal Resistance, 14L-PDIP	θ_{JA}	—	70	—	°C/W	
Thermal Resistance, 14L-SOIC	θ_{JA}	—	95.3	—	°C/W	
Thermal Resistance, 14L-TSSOP	θ_{JA}	—	100	—	°C/W	

Note 1: The MCP606/7/8/9 operate over this extended temperature range, but with reduced performance. In any case, the Junction Temperature (T_J) must not exceed the Absolute Maximum specification of $+150^\circ\text{C}$.

1.1 Test Circuits

The test circuits used for the DC and AC tests are shown in [Figure 1-2](#) and [Figure 1-3](#). The bypass capacitors are laid out according to the rules discussed in [Section 4.5 “Supply Bypass”](#).

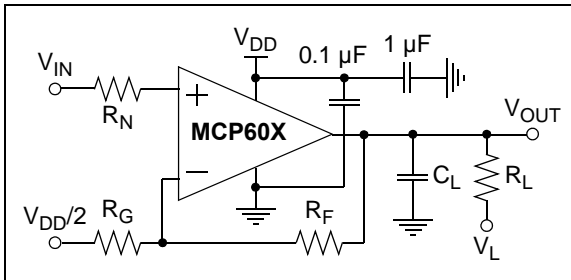

FIGURE 1-2: AC and DC Test Circuit for Most Non-Inverting Gain Conditions.

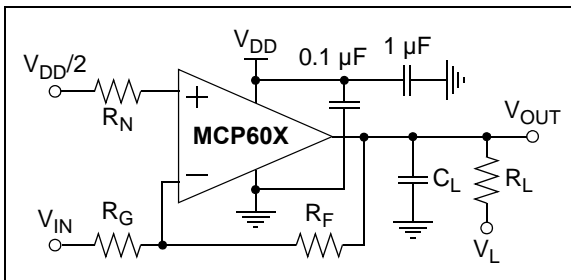

FIGURE 1-3: AC and DC Test Circuit for Most Inverting Gain Conditions.

MCP606/7/8/9

NOTES:

2.0 TYPICAL PERFORMANCE CURVES

Note: The graphs and tables provided following this note are a statistical summary based on a limited number of samples and are provided for informational purposes only. The performance characteristics listed herein are not tested or guaranteed. In some graphs or tables, the data presented may be outside the specified operating range (e.g., outside specified power supply range) and therefore outside the warranted range.

Note: Unless otherwise indicated, $V_{DD} = +2.5V$ to $+5.5V$, $V_{SS} = GND$, $T_A = +25^\circ C$, $V_{CM} = V_{DD}/2$, $V_{OUT} \approx V_{DD}/2$, $V_L = V_{DD}/2$, $R_L = 100\text{ k}\Omega$ to V_L , $C_L = 60\text{ pF}$, and CS is tied low.

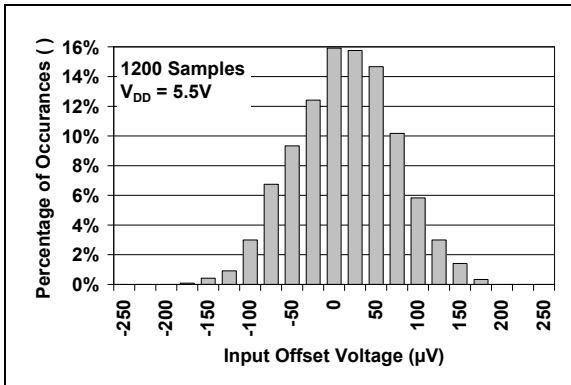

FIGURE 2-1: Input Offset Voltage at $V_{DD} = 5.5V$.

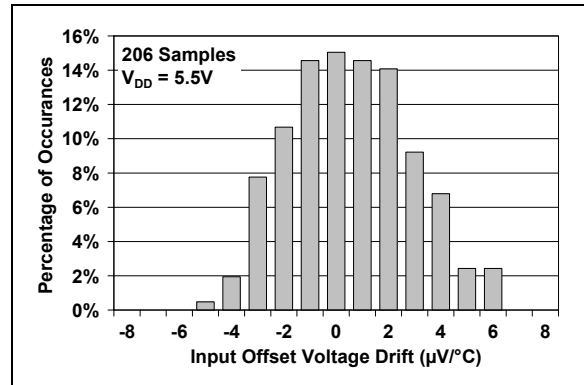

FIGURE 2-4: Input Offset Voltage Drift Magnitude at $V_{DD} = 5.5V$.

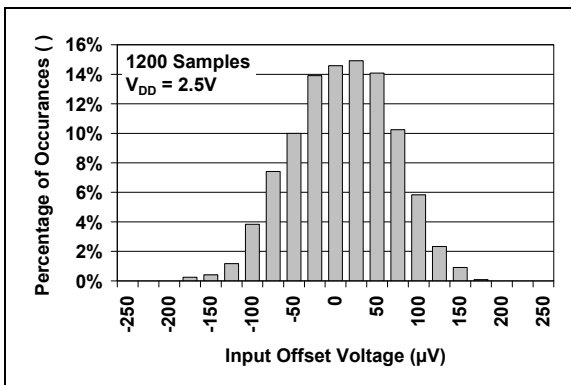

FIGURE 2-2: Input Offset Voltage at $V_{DD} = 2.5V$.

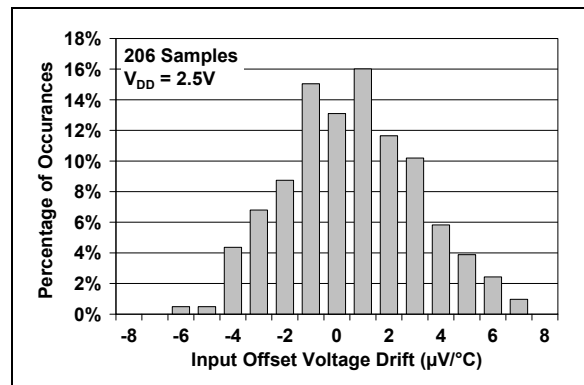

FIGURE 2-5: Input Offset Voltage Drift Magnitude at $V_{DD} = 2.5V$.

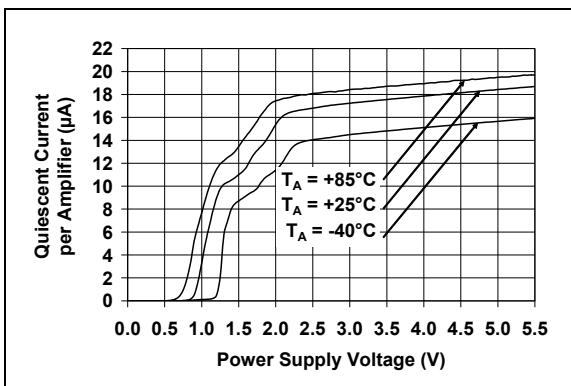

FIGURE 2-3: Quiescent Current vs. Power Supply Voltage.

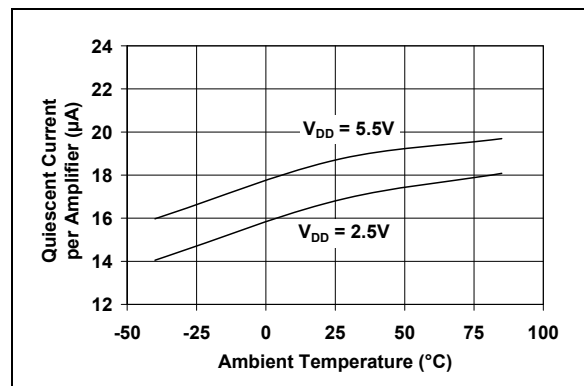

FIGURE 2-6: Quiescent Current vs. Ambient Temperature.

MCP606/7/8/9

Note: Unless otherwise indicated, $V_{DD} = +2.5V$ to $+5.5V$, $V_{SS} = GND$, $T_A = +25^\circ C$, $V_{CM} = V_{DD}/2$, $V_{OUT} \approx V_{DD}/2$, $V_L = V_{DD}/2$, $R_L = 100\text{ k}\Omega$ to V_L , $C_L = 60\text{ pF}$, and \overline{CS} is tied low.

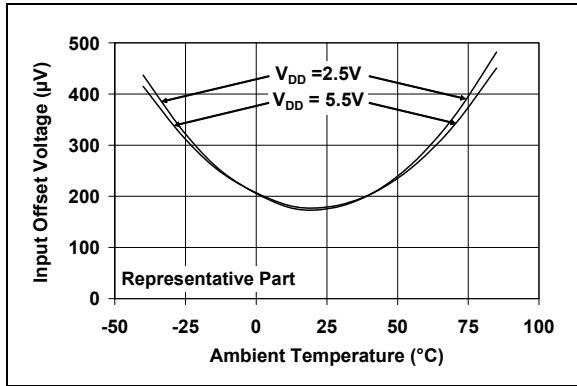

FIGURE 2-7: Input Offset Voltage vs. Ambient Temperature.

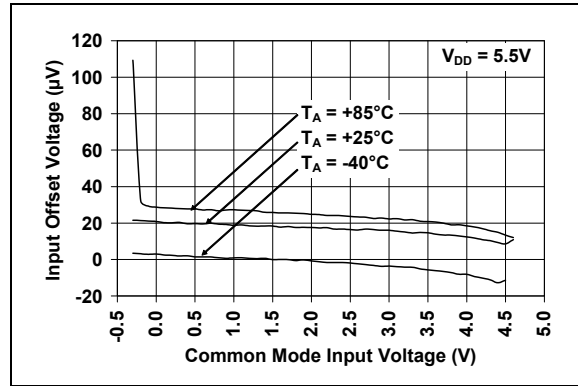

FIGURE 2-10: Input Offset Voltage vs. Common Mode Input Voltage.

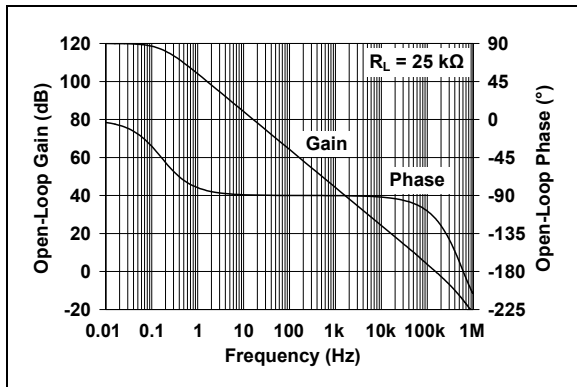

FIGURE 2-8: Open-Loop Gain and Phase vs. Frequency.

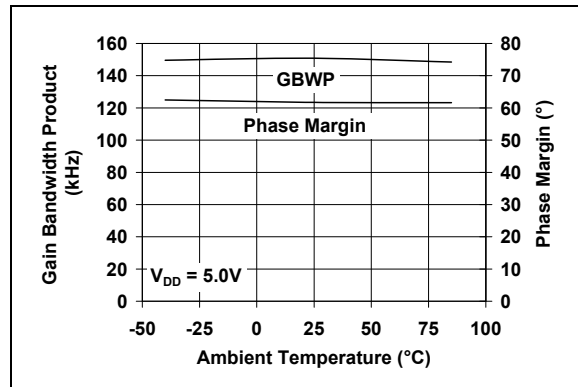

FIGURE 2-11: Gain Bandwidth Product, Phase Margin vs. Ambient Temperature.

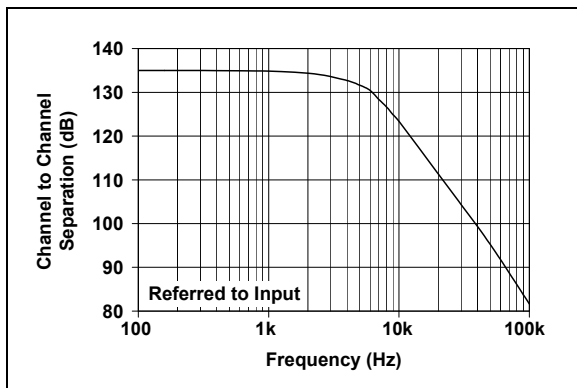

FIGURE 2-9: Channel-to-Channel Separation (MCP607 and MCP609 only).

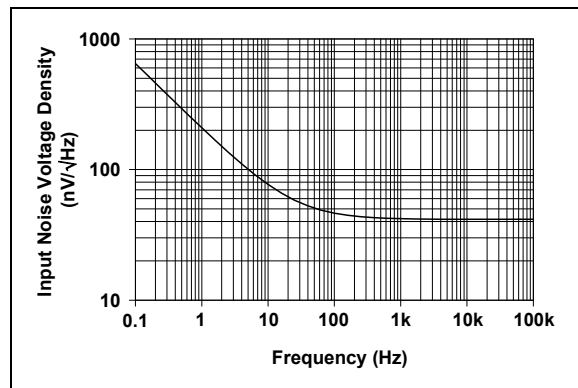

FIGURE 2-12: Input Noise Voltage Density vs. Frequency.

Note: Unless otherwise indicated, $V_{DD} = +2.5V$ to $+5.5V$, $V_{SS} = GND$, $T_A = +25^\circ C$, $V_{CM} = V_{DD}/2$, $V_{OUT} \approx V_{DD}/2$, $V_L = V_{DD}/2$, $R_L = 100\text{ k}\Omega$ to V_L , $C_L = 60\text{ pF}$, and \overline{CS} is tied low.

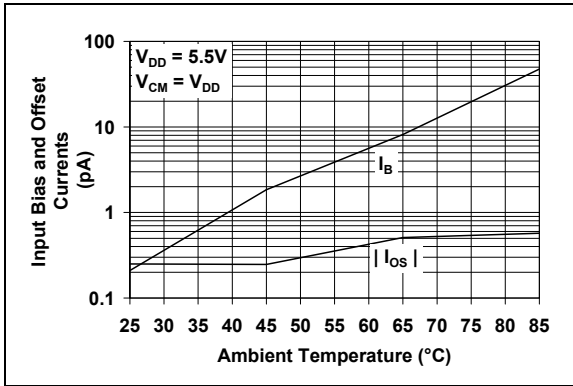

FIGURE 2-13: Input Bias Current, Input Offset Current vs. Ambient Temperature.

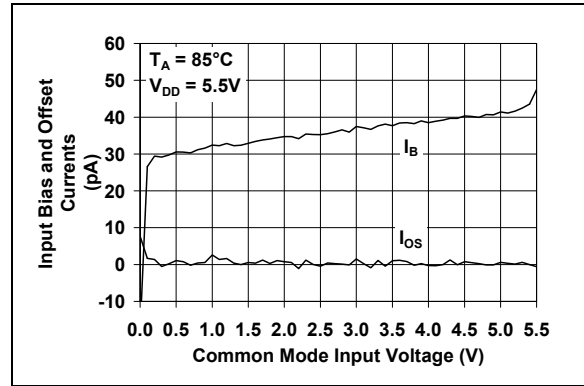

FIGURE 2-16: Input Bias Current, Input Offset Current vs. Common Mode Input Voltage.

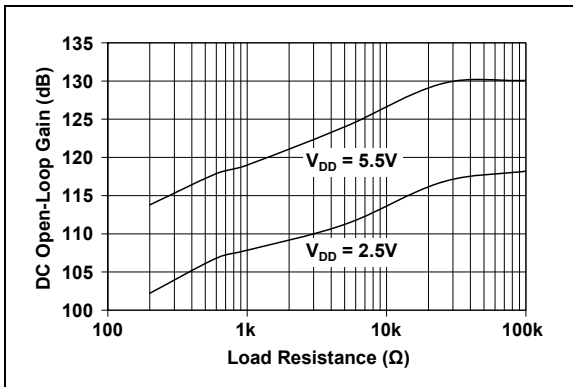

FIGURE 2-14: DC Open-Loop Gain vs. Load Resistance.

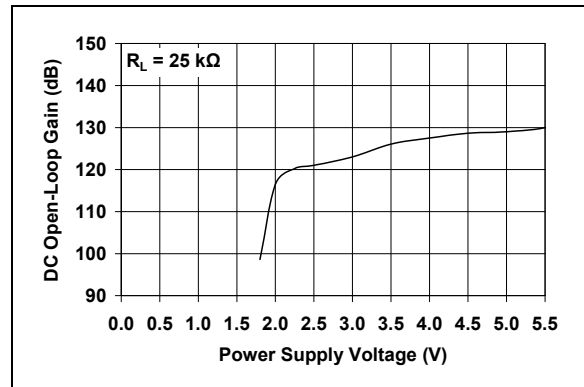

FIGURE 2-17: DC Open-Loop Gain vs. Power Supply Voltage.

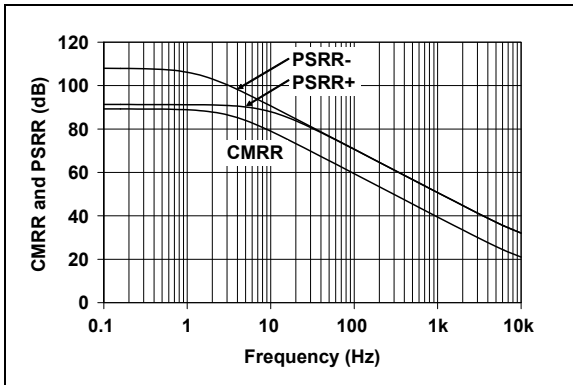

FIGURE 2-15: CMRR, PSRR vs. Frequency.

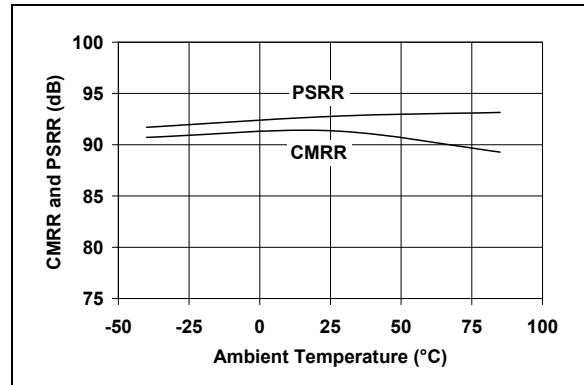

FIGURE 2-18: CMRR, PSRR vs. Ambient Temperature.

MCP606/7/8/9

Note: Unless otherwise indicated, $V_{DD} = +2.5V$ to $+5.5V$, $V_{SS} = GND$, $T_A = +25^\circ C$, $V_{CM} = V_{DD}/2$, $V_{OUT} \approx V_{DD}/2$, $V_L = V_{DD}/2$, $R_L = 100\text{ k}\Omega$ to V_L , $C_L = 60\text{ pF}$, and \overline{CS} is tied low.

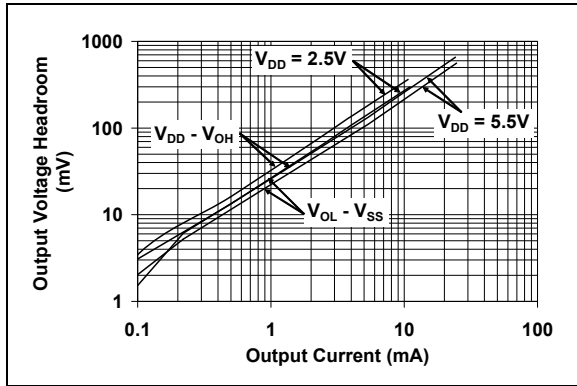

FIGURE 2-19: Output Voltage Headroom vs. Output Current Magnitude.

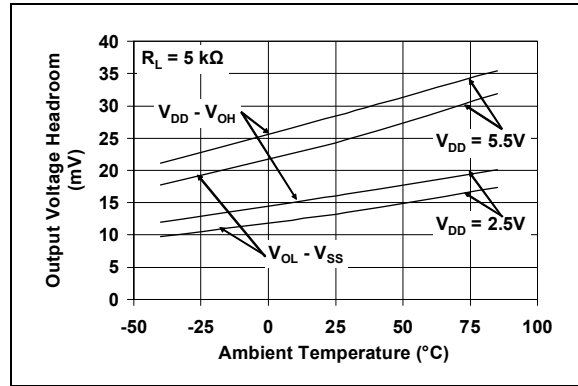

FIGURE 2-22: Output Voltage Headroom vs. Ambient Temperature at $R_L = 5\text{ k}\Omega$.

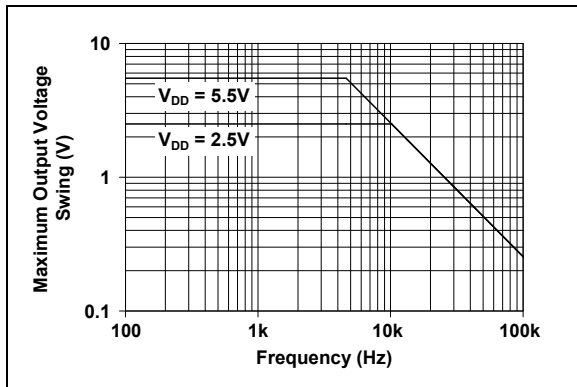

FIGURE 2-20: Maximum Output Voltage Swing vs. Frequency.

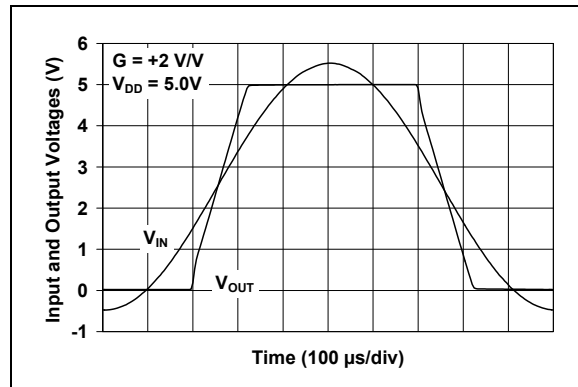

FIGURE 2-23: The MCP606/7/8/9 Show No Phase Reversal.

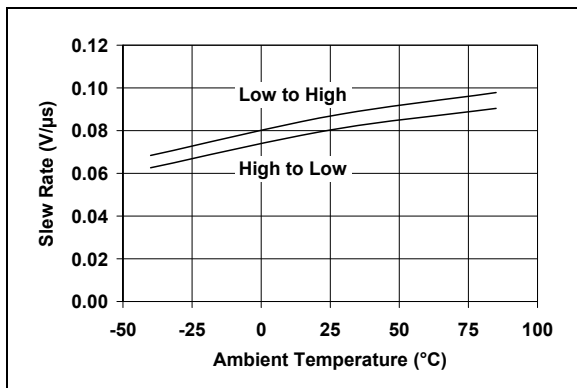

FIGURE 2-21: Slew Rate vs. Ambient Temperature.

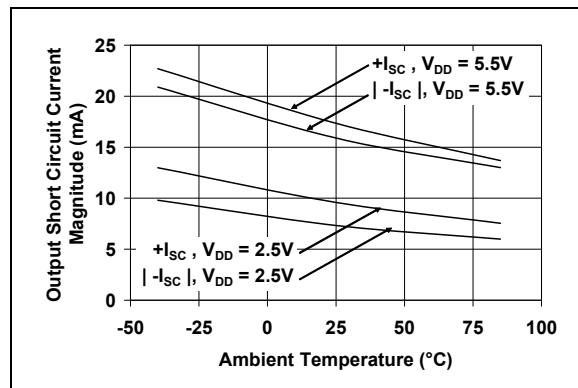

FIGURE 2-24: Output Short Circuit Current Magnitude vs. Ambient Temperature.

Note: Unless otherwise indicated, $V_{DD} = +2.5V$ to $+5.5V$, $V_{SS} = GND$, $T_A = +25^\circ C$, $V_{CM} = V_{DD}/2$, $V_{OUT} \approx V_{DD}/2$, $V_L = V_{DD}/2$, $R_L = 100\text{ k}\Omega$ to V_L , $C_L = 60\text{ pF}$, and \overline{CS} is tied low.

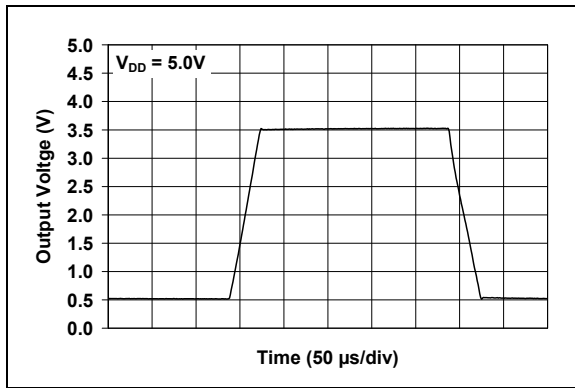

FIGURE 2-25: Large-signal, Non-inverting Pulse Response.

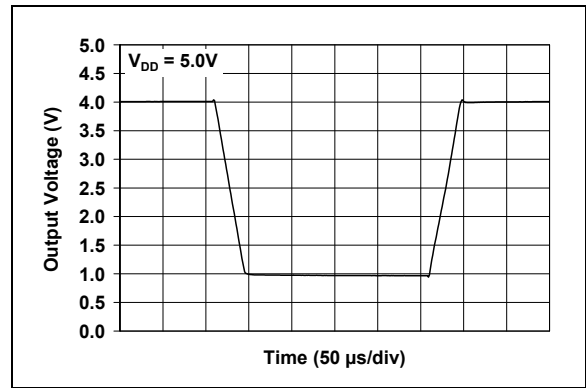

FIGURE 2-28: Large-signal, Inverting Pulse Response.

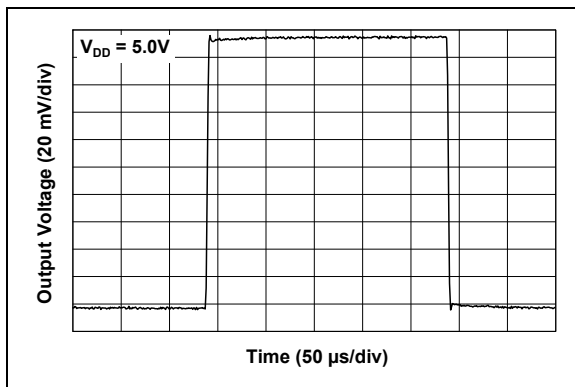

FIGURE 2-26: Small-signal, Non-inverting Pulse Response.

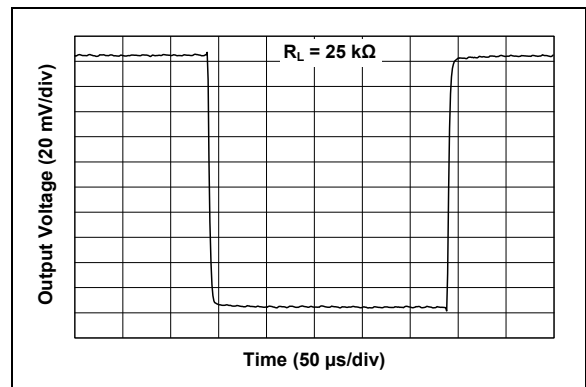

FIGURE 2-29: Small-signal, Inverting Pulse Response.

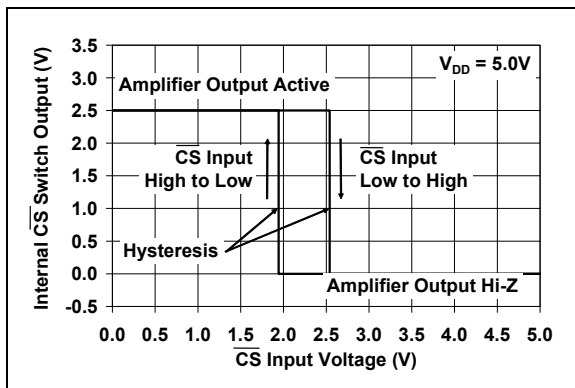

FIGURE 2-27: Chip Select (\overline{CS}) Hysteresis (MCP608 only).

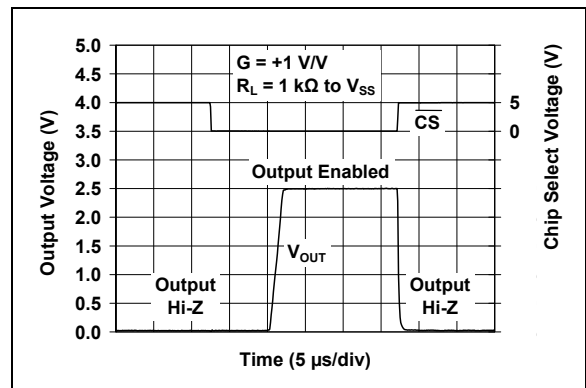

FIGURE 2-30: Amplifier Output Response Times vs. Chip Select (\overline{CS}) Pulse (MCP608 only).

MCP606/7/8/9

Note: Unless otherwise indicated, $V_{DD} = +2.5V$ to $+5.5V$, $V_{SS} = GND$, $T_A = +25^\circ C$, $V_{CM} = V_{DD}/2$, $V_{OUT} \approx V_{DD}/2$, $V_L = V_{DD}/2$, $R_L = 100\text{ k}\Omega$ to V_L , $C_L = 60\text{ pF}$, and \overline{CS} is tied low.

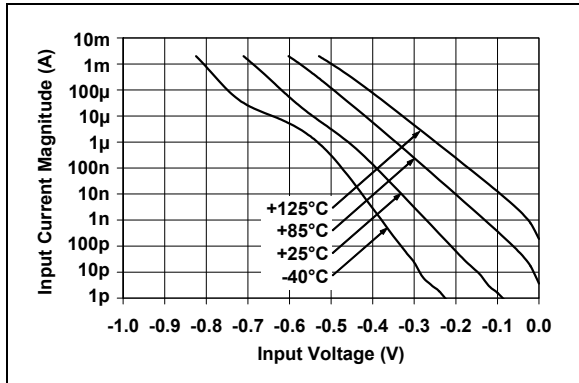

FIGURE 2-31: Measured Input Current vs. Input Voltage (below V_{SS}).

3.0 PIN DESCRIPTIONS

Descriptions of the pins are listed in [Table 3-1](#).

TABLE 3-1: PIN FUNCTION TABLE

MCP606		MCP607	MCP608	MCP609	Symbol	Description
PDIP, SOIC, TSSOP	SOT-23-5					
6	1	1	6	1	V_{OUT} , V_{OUTA}	Output (op amp A)
2	4	2	2	2	V_{IN-} , V_{INA-}	Inverting Input (op amp A)
3	3	3	3	3	V_{IN+} , V_{INA+}	Non-inverting Input (op amp A)
7	5	8	7	4	V_{DD}	Positive Power Supply
—	—	5	—	5	V_{INB+}	Non-inverting Input (op amp B)
—	—	6	—	6	V_{INB-}	Inverting Input (op amp B)
—	—	7	—	7	V_{OUTB}	Output (op amp B)
—	—	—	—	8	V_{OUTC}	Output (op amp B)
—	—	—	—	9	V_{INC-}	Inverting Input (op amp C)
—	—	—	—	10	V_{INC+}	Non-inverting Input (op amp C)
4	2	4	4	11	V_{SS}	Negative Power Supply
—	—	—	—	12	V_{IND+}	Non-inverting Input (op amp D)
—	—	—	—	13	V_{IND-}	Inverting Input (op amp D)
—	—	—	—	14	V_{OUTD}	Output (op amp D)
—	—	—	8	—	\overline{CS}	Chip Select
1, 5, 8	—	—	1, 5	—	NC	No Internal Connection

3.1 Analog Outputs

The output pins are low-impedance voltage sources.

3.2 Analog Inputs

The non-inverting and inverting inputs are high-impedance CMOS inputs with low bias currents.

3.3 Chip Select Digital Input

The Chip Select (\overline{CS}) pin is a Schmitt-triggered, CMOS logic input. It is used to place the MCP608 op amp in a Low-power mode, with the output(s) in a Hi-Z state.

3.4 Power Supply Pins

The positive power supply pin (V_{DD}) is 2.5V to 5.5V higher than the negative power supply pin (V_{SS}). For normal operation, the output pins are at voltages between V_{SS} and V_{DD} ; while the input pins are at voltages between $V_{SS} - 0.3V$ and $V_{DD} + 0.3V$.

Typically, these parts are used in a single-supply (positive) configuration. In this case, V_{SS} is connected to ground and V_{DD} is connected to the supply. V_{DD} will need bypass capacitors.

MCP606/7/8/9

NOTES:

4.0 APPLICATIONS INFORMATION

The MCP606/7/8/9 family of op amps is manufactured using Microchip's state-of-the-art CMOS process. These op amps are unity-gain stable and suitable for a wide range of general purpose applications.

4.1 Rail-to-Rail Inputs

4.1.1 PHASE REVERSAL

The MCP606/7/8/9 op amp is designed to prevent phase reversal when the input pins exceed the supply voltages. Figure 2-23 shows the input voltage exceeding the supply voltage without any phase reversal.

4.1.2 INPUT VOLTAGE AND CURRENT LIMITS

The ESD protection on the inputs can be depicted as shown in Figure 4-1. This structure was chosen to protect the input transistors, and to minimize input bias current (I_B). The input ESD diodes clamp the inputs when they try to go more than one diode drop below V_{SS} . They also clamp any voltages that go too far above V_{DD} ; their breakdown voltage is high enough to allow normal operation, and low enough to bypass quick ESD events within the specified limits.

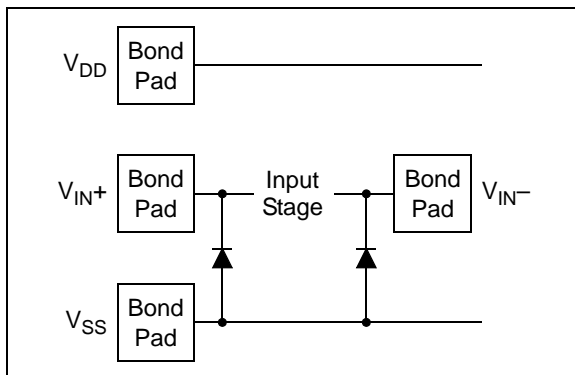

FIGURE 4-1: Simplified Analog Input ESD Structures.

In order to prevent damage and/or improper operation of these op amps, the circuit they are in must limit the currents and voltages at the V_{IN+} and V_{IN-} pins (see **Absolute Maximum Ratings** † at the beginning of **Section 1.0 “Electrical Characteristics”**). Figure 4-2 shows the recommended approach to protecting these inputs. The internal ESD diodes prevent the input pins (V_{IN+} and V_{IN-}) from going too far below ground, and the resistors R_1 and R_2 limit the possible current drawn out of the input pins. Diodes D_1 and D_2 prevent the input pins (V_{IN+} and V_{IN-}) from going too far above V_{DD} , and dump any currents onto V_{DD} . When implemented as shown, resistors R_1 and R_2 also limit the current through D_1 and D_2 .

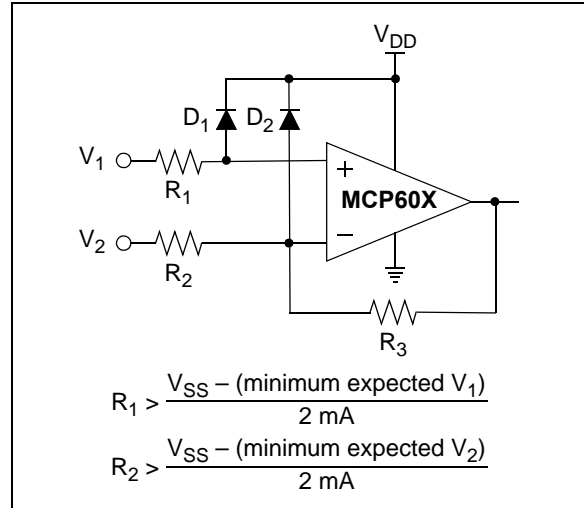

FIGURE 4-2: Protecting the Analog Inputs.

It is also possible to connect the diodes to the left of resistors R_1 and R_2 . In this case, current through the diodes D_1 and D_2 needs to be limited by some other mechanism. The resistors then serve as in-rush current limiters; the DC current into the input pins (V_{IN+} and V_{IN-}) should be very small.

A significant amount of current can flow out of the inputs when the common mode voltage (V_{CM}) is below ground (V_{SS}); see Figure 2-31. Applications that are high impedance may need to limit the useable voltage range.

4.1.3 NORMAL OPERATION

The input stage of the MCP606/7/8/9 op amps use a PMOS input stage. It operates at low common mode input voltage (V_{CM}), including ground. With this topology, the device operates with V_{CM} up to $V_{DD} - 1.1V$ and $0.3V$ below V_{SS} .

Figure 4-3 shows a unity gain buffer. Since V_{OUT} is the same voltage as the inverting input, V_{OUT} must be kept below $V_{DD} - 1.2V$ for correct operation.

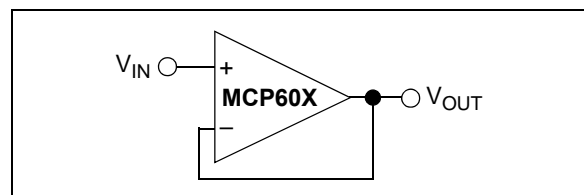

FIGURE 4-3: Unity Gain Buffer has a Limited V_{OUT} Range.

MCP606/7/8/9

4.2 Rail-to-Rail Output

There are two specifications that describe the output-swing capability of the MCP606/7/8/9 family of op amps. The first specification (Maximum Output Voltage Swing) defines the absolute maximum swing that can be achieved under the specified load conditions. For instance, the output voltage swings to within 15 mV of the negative rail with a 25 k Ω load to $V_{DD}/2$. Figure 2-23 shows how the output voltage is limited when the input goes beyond the linear region of operation.

The second specification that describes the output-swing capability of these amplifiers (Linear Output Voltage Range) defines the maximum output swing that can be achieved while the amplifier still operates in its linear region. To verify linear operation in this range, the large-signal DC Open-Loop Gain (A_{OL}) is measured at points inside the supply rails. The measurement must meet the specified A_{OL} conditions in the specification table.

4.3 Capacitive Loads

Driving large capacitive loads can cause stability problems for voltage-feedback op amps. As the load capacitance increases, the feedback loop's phase margin decreases and the closed-loop bandwidth is reduced. This produces gain-peaking in the frequency response, with overshoot and ringing in the step response. A unity-gain buffer ($G = +1$) is the most sensitive to capacitive loads, though all gains show the same general behavior.

When driving large capacitive loads with these op amps (e.g., > 60 pF when $G = +1$), a small series resistor at the output (R_{ISO} in Figure 4-4) improves the feedback loop's phase margin (stability) by making the output load resistive at higher frequencies. The bandwidth will be generally lower than the bandwidth with no capacitive load.

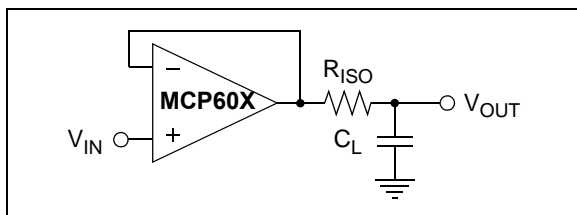

FIGURE 4-4: Output Resistor, R_{ISO} stabilizes large capacitive loads.

Figure 4-5 gives recommended R_{ISO} values for different capacitive loads and gains. The x-axis is the normalized load capacitance (C_L/G_N), where G_N is the circuit's noise gain. For non-inverting gains, G_N and the Signal Gain are equal. For inverting gains, G_N is $1+|\text{Signal Gain}|$ (e.g., -1 V/V gives $G_N = +2$ V/V).

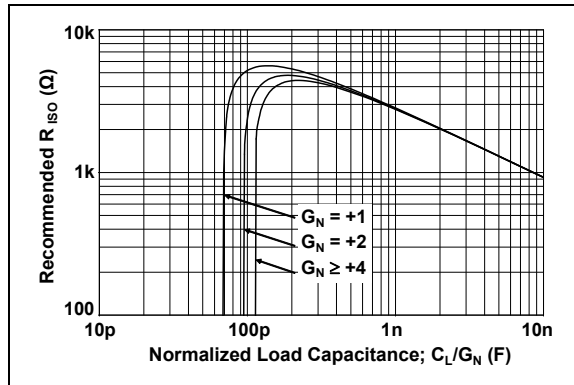

FIGURE 4-5: Recommended R_{ISO} Values for Capacitive Loads.

After selecting R_{ISO} for your circuit, double-check the resulting frequency response peaking and step response overshoot. Modify R_{ISO} 's value until the response is reasonable. Bench evaluation and simulations with the MCP606/7/8/9 SPICE macro model are helpful.

4.4 MCP608 Chip Select

The MCP608 is a single op amp with Chip Select (\overline{CS}). When \overline{CS} is pulled high, the supply current drops to 50 nA (typical) and flows through the \overline{CS} pin to V_{SS} . When this happens, the amplifier output is put into a high-impedance state. By pulling \overline{CS} low, the amplifier is enabled. The \overline{CS} pin has an internal 5 M Ω (typical) pull-down resistor connected to V_{SS} , so it will go low if the \overline{CS} pins is left floating. Figure 1-1 shows the output voltage and supply current response to a \overline{CS} pulse.

4.5 Supply Bypass

With this family of operational amplifiers, the power supply pin (V_{DD} for single-supply) should have a local bypass capacitor (i.e., 0.01 μ F to 0.1 μ F) within 2 mm for good high-frequency performance. It also needs a bulk capacitor (i.e., 1 μ F or larger) within 100 mm to provide large, slow currents. This bulk capacitor can be shared with other nearby analog parts.

4.6 Unused Op Amps

An unused op amp in a quad package (MCP609) should be configured as shown in Figure 4-6. These circuits prevent the output from toggling and causing crosstalk. Circuit A sets the op amp at its minimum noise gain. The resistor divider produces any desired reference voltage within the output voltage range of the op amp; the op amp buffers that reference voltage. Circuit B uses the minimum number of components and operates as a comparator, but it may draw more current.

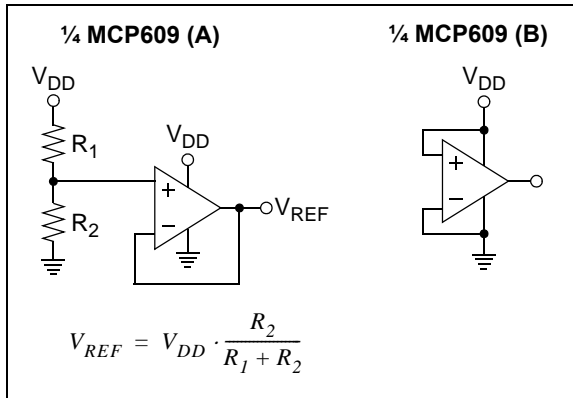

FIGURE 4-6: Unused Op Amps.

4.7 PCB Surface Leakage

In applications where low input bias current is critical, Printed Circuit Board (PCB) surface-leakage effects need to be considered. Surface leakage is caused by humidity, dust or other contamination on the board. Under low humidity conditions, a typical resistance between nearby traces is $10^{12}\Omega$. A 5V difference would cause 5 pA of current to flow, which is greater than the MCP606/7/8/9 family's bias current at +25°C (1 pA, typical).

The easiest way to reduce surface leakage is to use a guard ring around sensitive pins (or traces). The guard ring is biased at the same voltage as the sensitive pin. An example of this type of layout is shown in Figure 4-7.

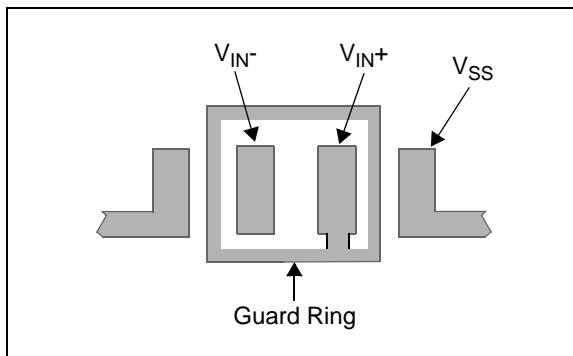

FIGURE 4-7: Example Guard Ring Layout for Inverting Gain.

1. Non-inverting Gain and Unity-gain Buffer:
 - a) Connect the non-inverting pin (V_{IN+}) to the input with a wire that does not touch the PCB surface.
 - b) Connect the guard ring to the inverting input pin (V_{IN-}). This biases the guard ring to the common mode input voltage.
2. Inverting Gain and Transimpedance Gain (convert current to voltage, such as photo detectors) amplifiers:
 - a) Connect the guard ring to the non-inverting input pin (V_{IN+}). This biases the guard ring to the same reference voltage as the op amp (e.g., $V_{DD}/2$ or ground).
 - b) Connect the inverting pin (V_{IN-}) to the input with a wire that does not touch the PCB surface.

4.8 Application Circuits

4.8.1 LOW-SIDE BATTERY CURRENT SENSOR

The MCP606/7/8/9 op amps can be used to sense the load current on the low-side of a battery using the circuit in Figure 4-8. In this circuit, the current from the power supply (minus the current required to power the MCP606) flows through a sense resistor (R_{SEN}), which converts it to voltage. This is gained by the the amplifier and resistors, R_G and R_F . Since the non-inverting input of the amplifier is at the load's negative supply (V_{LM}), the gain from R_{SEN} to V_{OUT} is R_F/R_G .

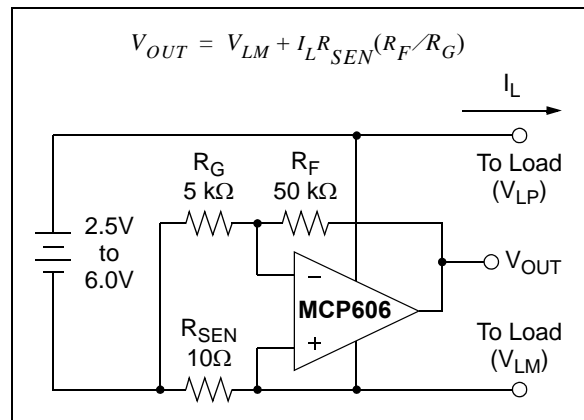

FIGURE 4-8: Low Side Battery Current Sensor.

Since the input bias current and input offset voltage of the MCP606 are low, and the input is capable of swinging below ground, there is very little error generated by the amplifier. The quiescent current is very low, which helps conserve battery power. The rail-to-rail output makes it possible to read very low currents.

MCP606/7/8/9

4.8.2 PHOTODIODE AMPLIFIERS

Sensors that produce an output current and have high output impedance can be connected to a transimpedance amplifier. The transimpedance amplifier converts the current into voltage. Photodiodes are one sensor that produce an output current.

The key op amp characteristics that are needed for these circuits are: low input offset voltage, low input bias current, high input impedance and an input common mode range that includes ground. The low input offset voltage and low input bias current support a very low voltage drop across the photodiode; this gives the best photodiode linearity. Since the photodiode is biased at ground, the op amp's input needs to function well both above and below ground.

4.8.2.1 Photo-Voltaic Mode

Figure 4-9 shows a transimpedance amplifier with a photodiode (D_1) biased in the Photo-voltaic mode (0V across D_1), which is used for precision photodiode sensing.

As light impinges on D_1 , charge is generated, causing a current to flow in the reverse bias direction of D_1 . The op amp's negative feedback forces the voltage across the D_1 to be nearly 0V. Resistor R_2 converts the current into voltage. Capacitor C_2 limits the bandwidth and helps stabilize the circuit when D_1 's junction capacitance is large.

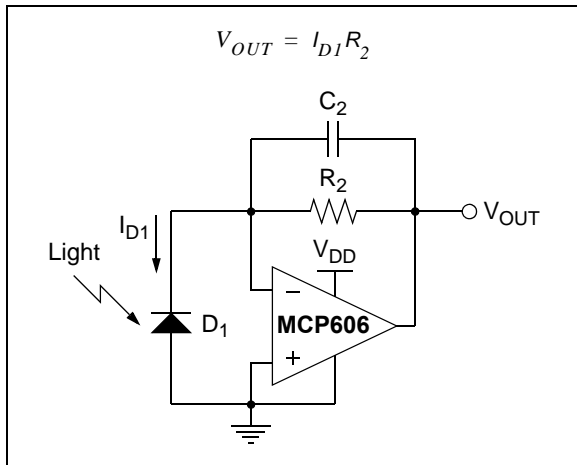

FIGURE 4-9: Photodiode (in Photo-voltaic mode) and Transimpedance Amplifier.

4.8.2.2 Photo-Conductive Mode

Figure 4-9 shows a transimpedance amplifier with a photodiode (D_1) biased in the Photo-conductive mode (D_1 is reverse biased), which is used for high-speed applications.

As light impinges on D_1 , charge is generated, causing a current to flow in the reverse bias direction of D_1 . Placing a negative bias on D_1 significantly reduces its junction capacitance, which allows the circuit to

operate at a much higher speed. This reverse bias also increases the dark current and current noise, however. Resistor R_2 converts the current into voltage. Capacitor C_2 limits the bandwidth and helps stabilize the circuit when D_1 's junction capacitance is large.

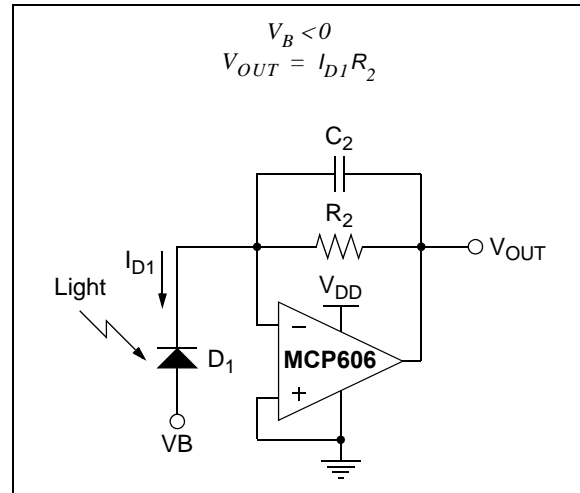

FIGURE 4-10: Photodiode (in Photo-conductive mode) and Transimpedance Amplifier.

4.8.3 TWO OP AMP INSTRUMENTATION AMPLIFIER

The two op amp instrumentation amplifier shown in Figure 4-11 serves the function of taking the difference of two input voltages, level-shifting it and gaining it to the output. This configuration is best suited for higher gains (i.e., gain > 3 V/V). The reference voltage (V_{REF}) is typically at mid-supply ($V_{DD}/2$) in a single-supply environment.

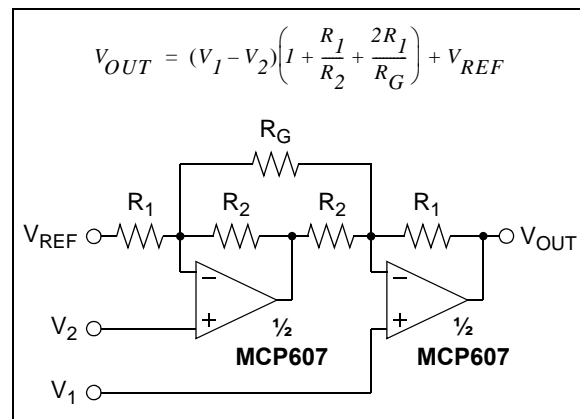

FIGURE 4-11: Two Op Amp Instrumentation Amplifier.

The key specifications that make the MCP606/7/8/9 family appropriate for this application circuit are low input bias current, low offset voltage and high common-mode rejection.

4.8.4 THREE OP AMP INSTRUMENTATION AMPLIFIER

A classic, three op amp instrumentation amplifier is illustrated in Figure 4-12. The two input op amps provide differential signal gain and a common mode gain of +1. The output op amp is a difference amplifier, which converts its input signal from differential to a single ended output; it rejects common mode signals at its input. The gain of this circuit is simply adjusted with one resistor (R_G). The reference voltage (V_{REF}) is typically referenced to mid-supply ($V_{DD}/2$) in single-supply applications.

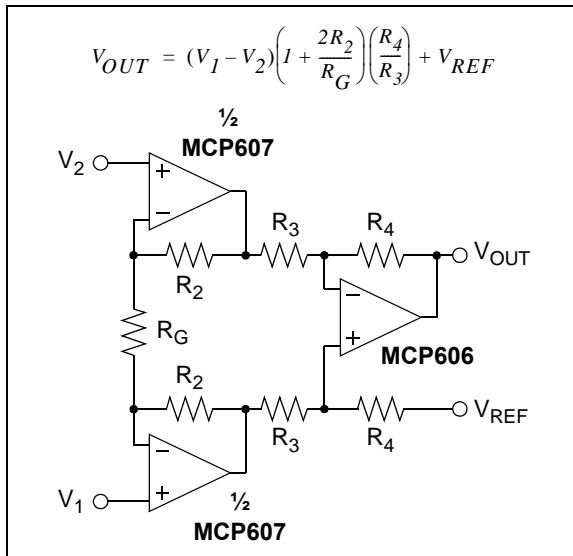

FIGURE 4-12: Three Op Amp Instrumentation Amplifier.

4.8.5 PRECISION GAIN WITH GOOD LOAD ISOLATION

In Figure 4-13, the MCP606 op amps, R_1 and R_2 provide a high gain to the input signal (V_{IN}). The MCP606's low offset voltage makes this an accurate circuit.

The MCP601 is configured as a unity-gain buffer. It isolates the MCP606's output from the load, increasing the high-gain stage's precision. Since the MCP601 has a higher output current, with the two amplifiers being housed in separate packages, there is minimal change in the MCP606's offset voltage due to loading effect.

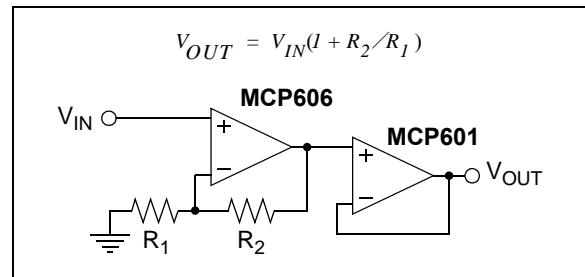

FIGURE 4-13: Precision Gain with Good Load Isolation.

MCP606/7/8/9

NOTES:

5.0 DESIGN AIDS

Microchip provides the basic design tools needed for the MCP606/7/8/9 family of op amps.

5.1 SPICE Macro Model

The latest SPICE macro model for the MCP606/7/8/9 op amps is available on the Microchip web site at www.microchip.com. This model is intended to be an initial design tool that works well in the op amp's linear region of operation over the temperature range. See the model file for information on its capabilities.

Bench testing is a very important part of any design and cannot be replaced with simulations. Also, simulation results using this macro model need to be validated by comparing them to the data sheet specifications and characteristic curves.

5.2 FilterLab[®] Software

Microchip's FilterLab[®] software is an innovative software tool that simplifies analog active filter (using op amps) design. Available at no cost from the Microchip web site at www.microchip.com/filterlab, the FilterLab design tool provides full schematic diagrams of the filter circuit with component values. It also outputs the filter circuit in SPICE format, which can be used with the macro model to simulate actual filter performance.

5.3 Mindi[™] Circuit Designer & Simulator

Microchip's Mindi[™] Circuit Designer & Simulator aids in the design of various circuits useful for active filter, amplifier and power-management applications. It is a free online circuit designer & simulator available from the Microchip web site at www.microchip.com/mindi. This interactive circuit designer & simulator enables designers to quickly generate circuit diagrams, simulate circuits. Circuits developed using the Mindi Circuit Designer & Simulator can be downloaded to a personal computer or workstation.

5.4 Microchip Advanced Part Selector (MAPS)

MAPS is a software tool that helps semiconductor professionals efficiently identify Microchip devices that fit a particular design requirement. Available at no cost from the Microchip website at www.microchip.com/maps, the MAPS is an overall selection tool for Microchip's product portfolio that includes Analog, Memory, MCUs and DSCs. Using this tool you can define a filter to sort features for a parametric search of devices and export side-by-side technical comparison reports. Helpful links are also provided for Datasheets, Purchase, and Sampling of Microchip parts.

5.5 Analog Demonstration and Evaluation Boards

Microchip offers a broad spectrum of Analog Demonstration and Evaluation Boards that are designed to help you achieve faster time to market. For a complete listing of these boards and their corresponding user's guides and technical information, visit the Microchip web site at www.microchip.com/analogtools.

Two of our boards that are especially useful are:

- 8-Pin SOIC/MSOP/TSSOP/DIP Evaluation Board, P/N SOIC8EV
- 14-Pin SOIC/TSSOP/DIP Evaluation Board, P/N SOIC14EV

5.6 Application Notes

The following Microchip Application Notes are available on the Microchip web site at www.microchip.com/appnotes and are recommended as supplemental reference resources.

- **ADN003:** "Select the Right Operational Amplifier for your Filtering Circuits", DS21821
- **AN722:** "Operational Amplifier Topologies and DC Specifications", DS00722
- **AN723:** "Operational Amplifier AC Specifications and Applications", DS00723
- **AN884:** "Driving Capacitive Loads With Op Amps", DS00884
- **AN990:** "Analog Sensor Conditioning Circuits – An Overview", DS00990

These application notes and others are listed in the design guide:

"Signal Chain Design Guide", DS21825

MCP606/7/8/9

NOTES:

6.0 PACKAGING INFORMATION

6.1 Package Marking Information

5-Lead SOT-23 (MCP606)

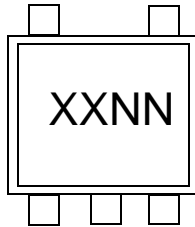

Example:

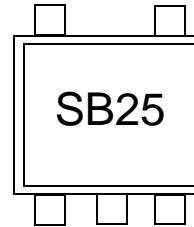

8-Lead PDIP (300 mil)

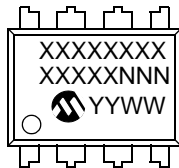

Example:

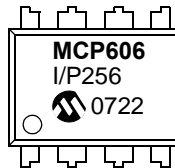

OR

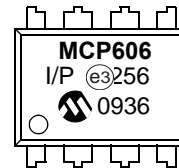

8-Lead SOIC (150 mil)

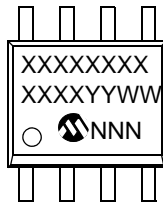

Example:

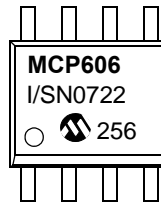

OR



8-Lead TSSOP

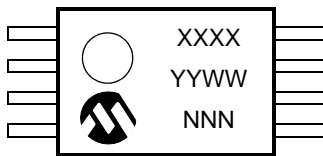

Example:

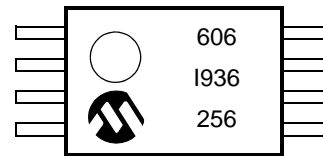

Legend:	XX...X	Customer-specific information
	Y	Year code (last digit of calendar year)
	YY	Year code (last 2 digits of calendar year)
	WW	Week code (week of January 1 is week '01')
	NNN	Alphanumeric traceability code
	e3	Pb-free JEDEC designator for Matte Tin (Sn)
	*	This package is Pb-free. The Pb-free JEDEC designator (e3) can be found on the outer packaging for this package.

Note: In the event the full Microchip part number cannot be marked on one line, it will be carried over to the next line, thus limiting the number of available characters for customer-specific information.

MCP606/7/8/9

Package Marking Information (Continued)

14-Lead PDIP (300 mil) (MCP609)

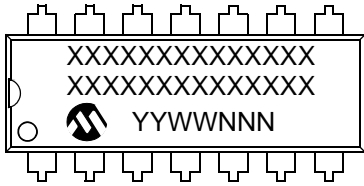

Example:

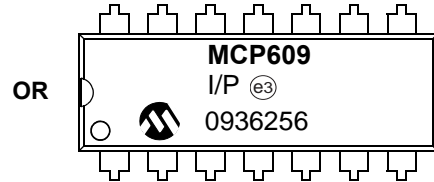
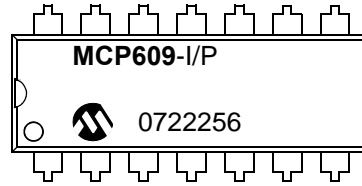

14-Lead SOIC (150 mil) (MCP609)

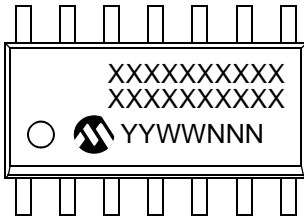

Example:

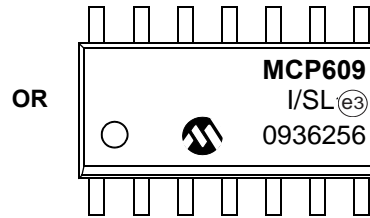
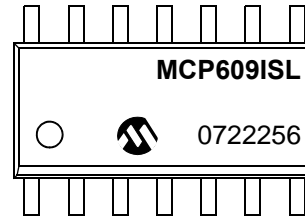

14-Lead TSSOP (MCP609)

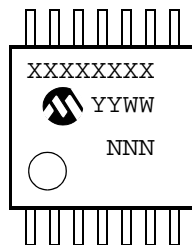

Example:

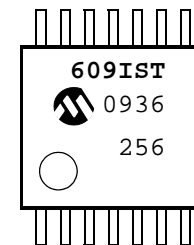

5-Lead Plastic Small Outline Transistor (OT) [SOT-23]

Note: For the most current package drawings, please see the Microchip Packaging Specification located at <http://www.microchip.com/packaging>

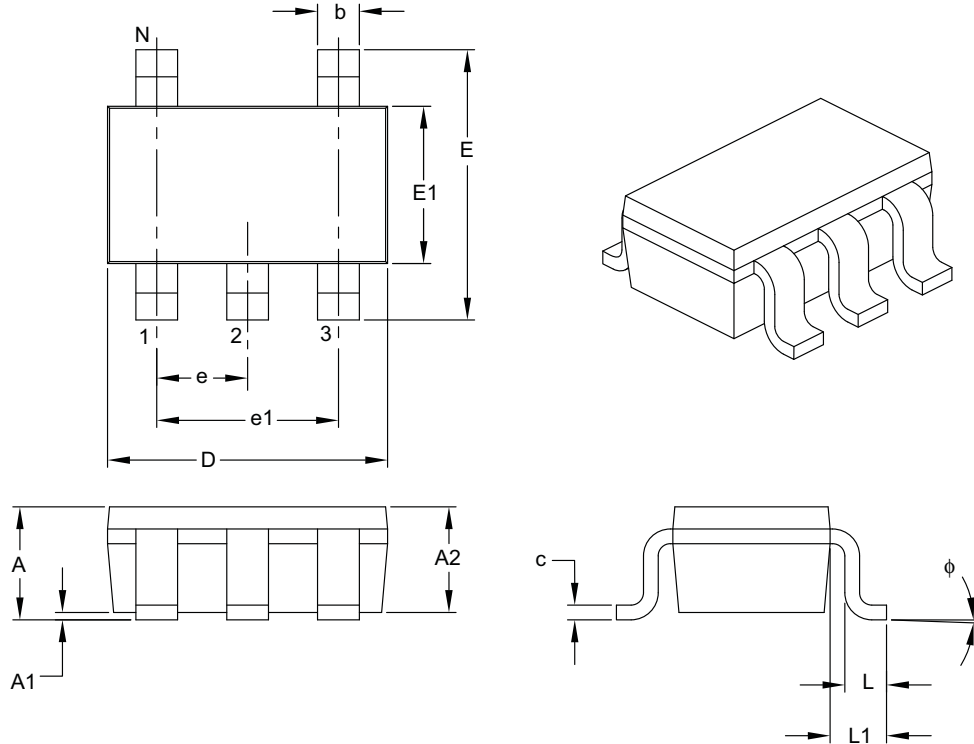

Dimension Limits	Units	MILLIMETERS		
		MIN	NOM	MAX
Number of Pins	N	5		
Lead Pitch	e	0.95 BSC		
Outside Lead Pitch	e1	1.90 BSC		
Overall Height	A	0.90	–	1.45
Molded Package Thickness	A2	0.89	–	1.30
Standoff	A1	0.00	–	0.15
Overall Width	E	2.20	–	3.20
Molded Package Width	E1	1.30	–	1.80
Overall Length	D	2.70	–	3.10
Foot Length	L	0.10	–	0.60
Footprint	L1	0.35	–	0.80
Foot Angle	ϕ	0°	–	30°
Lead Thickness	c	0.08	–	0.26
Lead Width	b	0.20	–	0.51

Notes:

- Dimensions D and E1 do not include mold flash or protrusions. Mold flash or protrusions shall not exceed 0.127 mm per side.
- Dimensioning and tolerancing per ASME Y14.5M.

BSC: Basic Dimension. Theoretically exact value shown without tolerances.

Microchip Technology Drawing C04-091B

MCP606/7/8/9

8-Lead Plastic Dual In-Line (P) – 300 mil Body [PDIP]

Note: For the most current package drawings, please see the Microchip Packaging Specification located at <http://www.microchip.com/packageing>

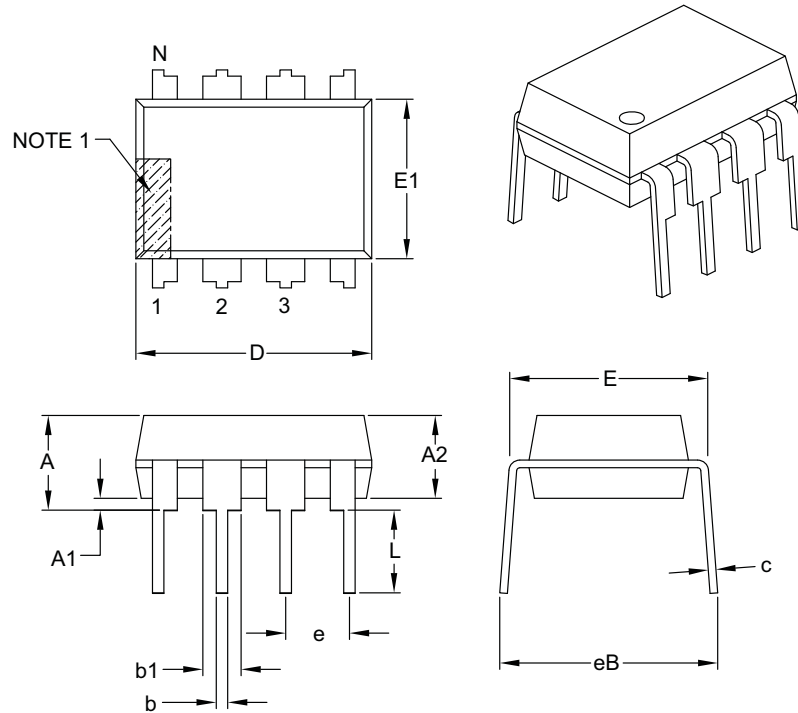

Dimension Limits	Units	INCHES		
		MIN	NOM	MAX
Number of Pins	N	8		
Pitch	e	.100 BSC		
Top to Seating Plane	A	–	–	.210
Molded Package Thickness	A2	.115	.130	.195
Base to Seating Plane	A1	.015	–	–
Shoulder to Shoulder Width	E	.290	.310	.325
Molded Package Width	E1	.240	.250	.280
Overall Length	D	.348	.365	.400
Tip to Seating Plane	L	.115	.130	.150
Lead Thickness	c	.008	.010	.015
Upper Lead Width	b1	.040	.060	.070
Lower Lead Width	b	.014	.018	.022
Overall Row Spacing §	eB	–	–	.430

Notes:

- Pin 1 visual index feature may vary, but must be located with the hatched area.
- § Significant Characteristic.
- Dimensions D and E1 do not include mold flash or protrusions. Mold flash or protrusions shall not exceed .010" per side.
- Dimensioning and tolerancing per ASME Y14.5M.
BSC: Basic Dimension. Theoretically exact value shown without tolerances.

Microchip Technology Drawing C04-018B

8-Lead Plastic Small Outline (SN) – Narrow, 3.90 mm Body [SOIC]

Note: For the most current package drawings, please see the Microchip Packaging Specification located at <http://www.microchip.com/packaging>

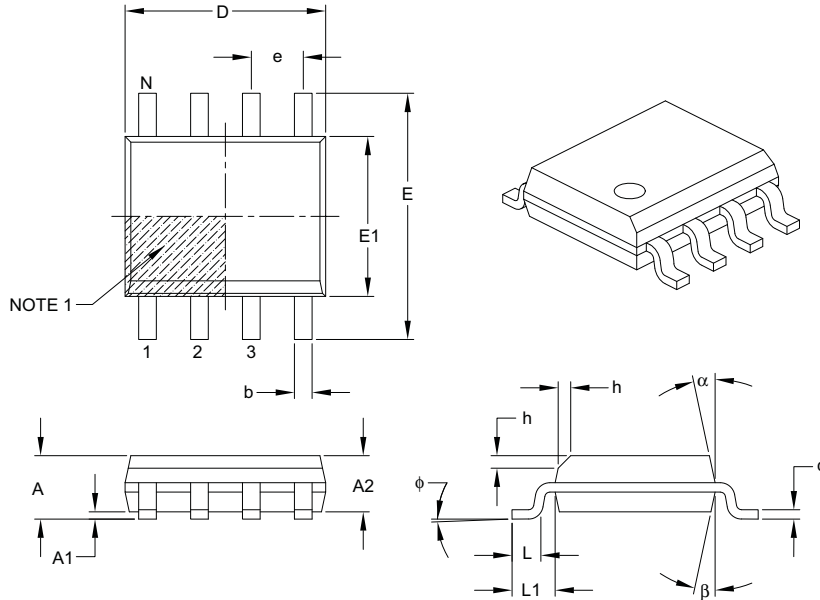

		Units	MILLIMETERS		
Dimension Limits			MIN	NOM	MAX
Number of Pins	N		8		
Pitch	e		1.27 BSC		
Overall Height	A		–	–	1.75
Molded Package Thickness	A2		1.25	–	–
Standoff §	A1		0.10	–	0.25
Overall Width	E		6.00 BSC		
Molded Package Width	E1		3.90 BSC		
Overall Length	D		4.90 BSC		
Chamfer (optional)	h		0.25	–	0.50
Foot Length	L		0.40	–	1.27
Footprint	L1		1.04 REF		
Foot Angle	ϕ		0°	–	8°
Lead Thickness	c		0.17	–	0.25
Lead Width	b		0.31	–	0.51
Mold Draft Angle Top	α		5°	–	15°
Mold Draft Angle Bottom	β		5°	–	15°

Notes:

1. Pin 1 visual index feature may vary, but must be located within the hatched area.
2. § Significant Characteristic.
3. Dimensions D and E1 do not include mold flash or protrusions. Mold flash or protrusions shall not exceed 0.15 mm per side.
4. Dimensioning and tolerancing per ASME Y14.5M.
 - BSC: Basic Dimension. Theoretically exact value shown without tolerances.
 - REF: Reference Dimension, usually without tolerance, for information purposes only.

Microchip Technology Drawing C04-057B

MCP606/7/8/9

8-Lead Plastic Small Outline (SN) – Narrow, 3.90 mm Body [SOIC]

Note: For the most current package drawings, please see the Microchip Packaging Specification located at <http://www.microchip.com/packaging>

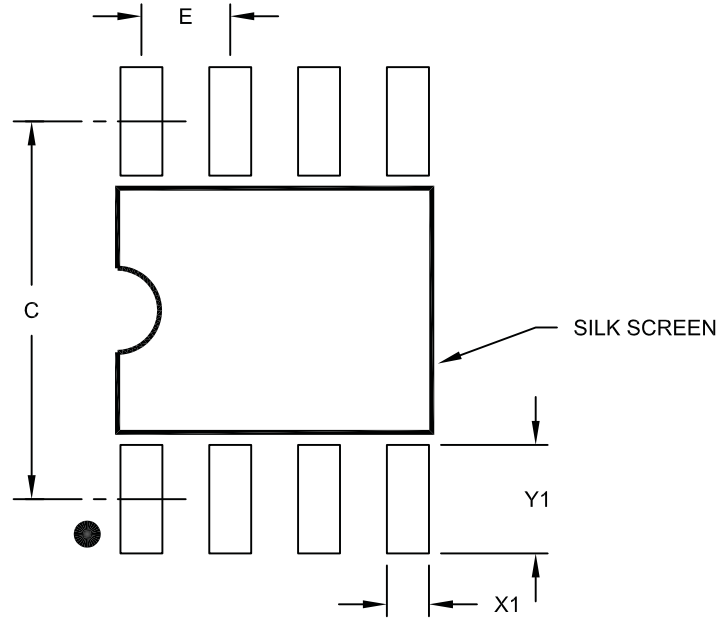

RECOMMENDED LAND PATTERN

		Units	MILLIMETERS		
Dimension Limits			MIN	NOM	MAX
Contact Pitch	E		1.27 BSC		
Contact Pad Spacing	C			5.40	
Contact Pad Width (X8)	X1				0.60
Contact Pad Length (X8)	Y1				1.55

Notes:

1. Dimensioning and tolerancing per ASME Y14.5M

BSC: Basic Dimension. Theoretically exact value shown without tolerances.

Microchip Technology Drawing No. C04-2057A

8-Lead Plastic Thin Shrink Small Outline (ST) – 4.4 mm Body [TSSOP]

Note: For the most current package drawings, please see the Microchip Packaging Specification located at <http://www.microchip.com/packaging>

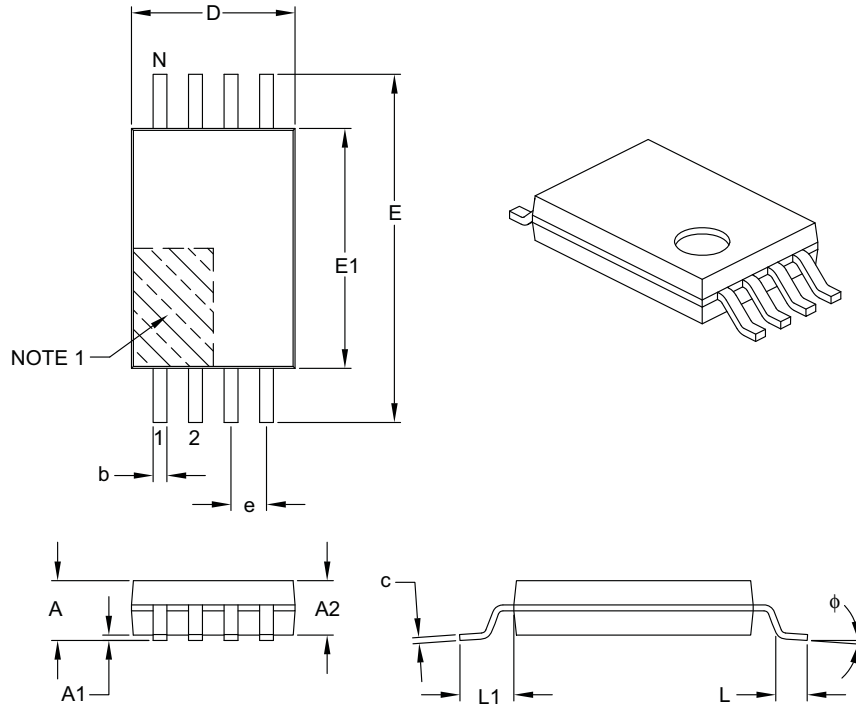

Dimension Limits	Units	MILLIMETERS		
		MIN	NOM	MAX
Number of Pins	N	8		
Pitch	e	0.65 BSC		
Overall Height	A	–	–	1.20
Molded Package Thickness	A2	0.80	1.00	1.05
Standoff	A1	0.05	–	0.15
Overall Width	E	6.40 BSC		
Molded Package Width	E1	4.30	4.40	4.50
Molded Package Length	D	2.90	3.00	3.10
Foot Length	L	0.45	0.60	0.75
Footprint	L1	1.00 REF		
Foot Angle	ϕ	0°	–	8°
Lead Thickness	c	0.09	–	0.20
Lead Width	b	0.19	–	0.30

Notes:

- Pin 1 visual index feature may vary, but must be located within the hatched area.
- Dimensions D and E1 do not include mold flash or protrusions. Mold flash or protrusions shall not exceed 0.15 mm per side.
- Dimensioning and tolerancing per ASME Y14.5M.

BSC: Basic Dimension. Theoretically exact value shown without tolerances.

REF: Reference Dimension, usually without tolerance, for information purposes only.

Microchip Technology Drawing C04-086B

MCP606/7/8/9

8-Lead Plastic Thin Shrink Small Outline (ST) - 4.4 mm Body [TSSOP]

Note: For the most current package drawings, please see the Microchip Packaging Specification located at <http://www.microchip.com/packaging>

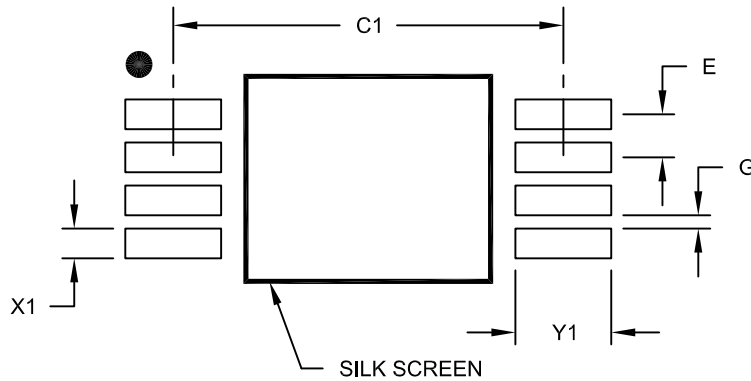

RECOMMENDED LAND PATTERN

Dimension Limits	Units	MILLIMETERS		
		MIN	NOM	MAX
Contact Pitch	E	0.65 BSC		
Contact Pad Spacing	C1		5.90	
Contact Pad Width (X28)	X1			0.45
Contact Pad Length (X28)	Y1			1.45
Distance Between Pads	G	0.20		

Notes:

1. Dimensioning and tolerancing per ASME Y14.5M

BSC: Basic Dimension, Theoretically exact value shown without tolerances.

Microchip Technology Drawing No. C04-2086A

14-Lead Plastic Dual In-Line (P) – 300 mil Body [PDIP]

Note: For the most current package drawings, please see the Microchip Packaging Specification located at <http://www.microchip.com/packaging>

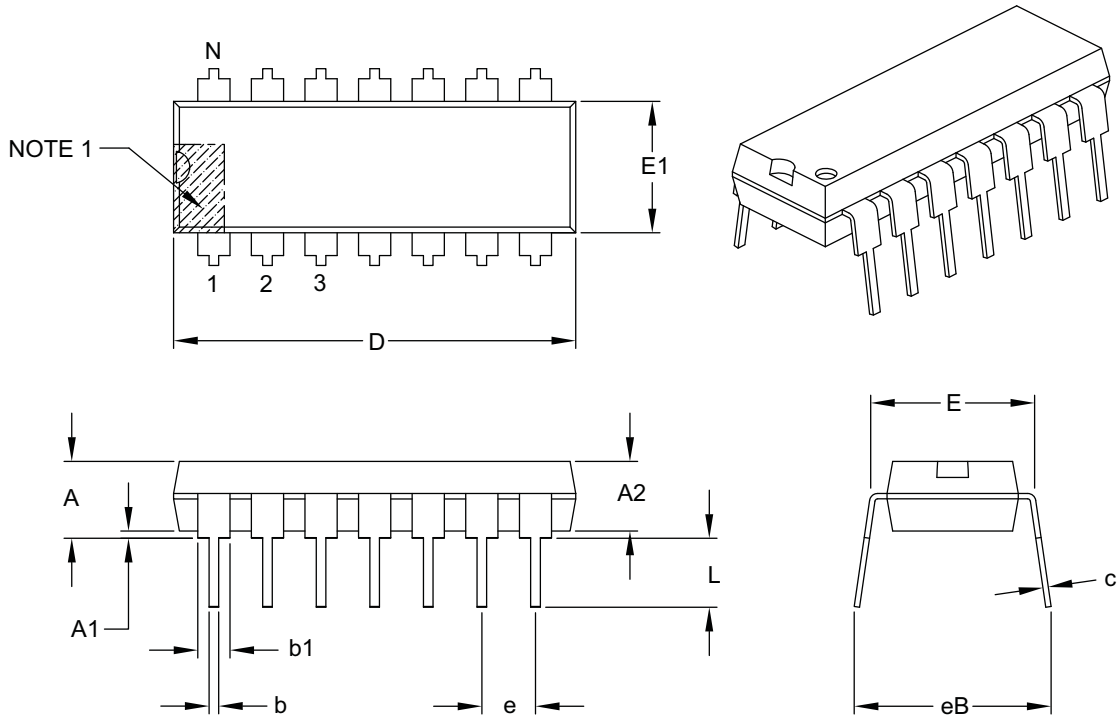

Dimension Limits	Units	INCHES		
		MIN	NOM	MAX
Number of Pins	N	14		
Pitch	e	.100 BSC		
Top to Seating Plane	A	–	–	.210
Molded Package Thickness	A2	.115	.130	.195
Base to Seating Plane	A1	.015	–	–
Shoulder to Shoulder Width	E	.290	.310	.325
Molded Package Width	E1	.240	.250	.280
Overall Length	D	.735	.750	.775
Tip to Seating Plane	L	.115	.130	.150
Lead Thickness	c	.008	.010	.015
Upper Lead Width	b1	.045	.060	.070
Lower Lead Width	b	.014	.018	.022
Overall Row Spacing §	eB	–	–	.430

Notes:

- Pin 1 visual index feature may vary, but must be located with the hatched area.
- § Significant Characteristic.
- Dimensions D and E1 do not include mold flash or protrusions. Mold flash or protrusions shall not exceed .010" per side.
- Dimensioning and tolerancing per ASME Y14.5M.
BSC: Basic Dimension. Theoretically exact value shown without tolerances.

Microchip Technology Drawing C04-005B

MCP606/7/8/9

14-Lead Plastic Small Outline (SL) – Narrow, 3.90 mm Body [SOIC]

Note: For the most current package drawings, please see the Microchip Packaging Specification located at <http://www.microchip.com/packaging>

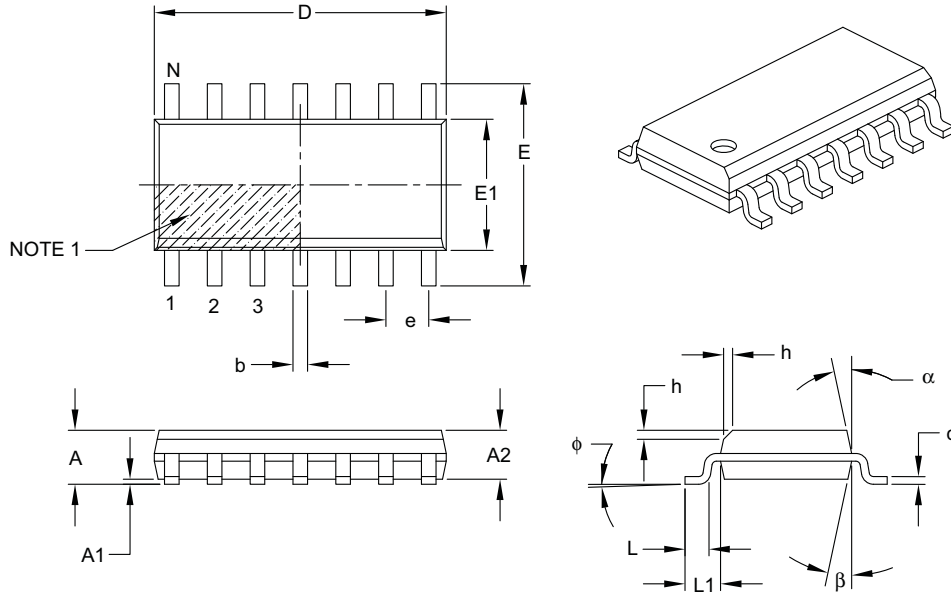

Dimension Limits	Units	MILLIMETERS		
		MIN	NOM	MAX
Number of Pins	N	14		
Pitch	e	1.27 BSC		
Overall Height	A	–	–	1.75
Molded Package Thickness	A2	1.25	–	–
Standoff §	A1	0.10	–	0.25
Overall Width	E	6.00 BSC		
Molded Package Width	E1	3.90 BSC		
Overall Length	D	8.65 BSC		
Chamfer (optional)	h	0.25	–	0.50
Foot Length	L	0.40	–	1.27
Footprint	L1	1.04 REF		
Foot Angle	ϕ	0°	–	8°
Lead Thickness	c	0.17	–	0.25
Lead Width	b	0.31	–	0.51
Mold Draft Angle Top	α	5°	–	15°
Mold Draft Angle Bottom	β	5°	–	15°

Notes:

- Pin 1 visual index feature may vary, but must be located within the hatched area.
- § Significant Characteristic.
- Dimensions D and E1 do not include mold flash or protrusions. Mold flash or protrusions shall not exceed 0.15 mm per side.
- Dimensioning and tolerancing per ASME Y14.5M.

BSC: Basic Dimension. Theoretically exact value shown without tolerances.

REF: Reference Dimension, usually without tolerance, for information purposes only.

Microchip Technology Drawing C04-065B

14-Lead Plastic Small Outline (SL) - Narrow, 3.90 mm Body [SOIC]

Note: For the most current package drawings, please see the Microchip Packaging Specification located at <http://www.microchip.com/packaging>

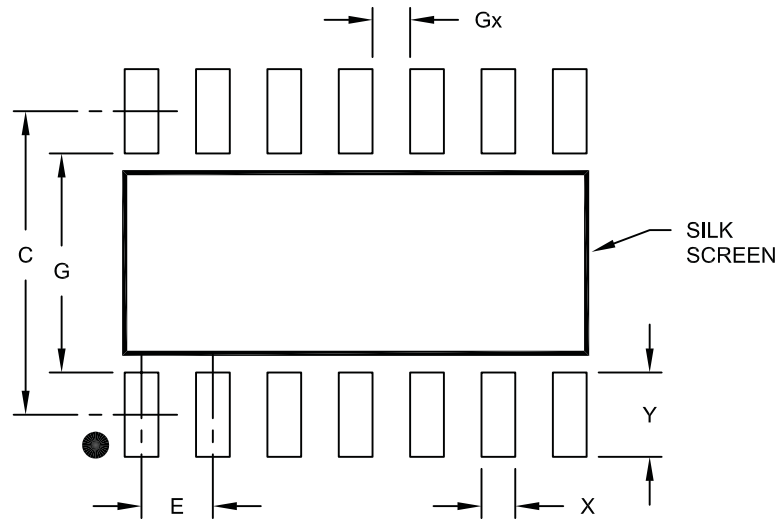

RECOMMENDED LAND PATTERN

Dimension Limits	Units	MILLIMETERS		
		MIN	NOM	MAX
Contact Pitch	E	1.27 BSC		
Contact Pad Spacing	C		5.40	
Contact Pad Width	X			0.60
Contact Pad Length	Y			1.50
Distance Between Pads	Gx	0.67		
Distance Between Pads	G	3.90		

Notes:

1. Dimensioning and tolerancing per ASME Y14.5M

BSC: Basic Dimension. Theoretically exact value shown without tolerances.

Microchip Technology Drawing No. C04-2065A

MCP606/7/8/9

14-Lead Plastic Thin Shrink Small Outline (ST) – 4.4 mm Body [TSSOP]

Note: For the most current package drawings, please see the Microchip Packaging Specification located at <http://www.microchip.com/packaging>

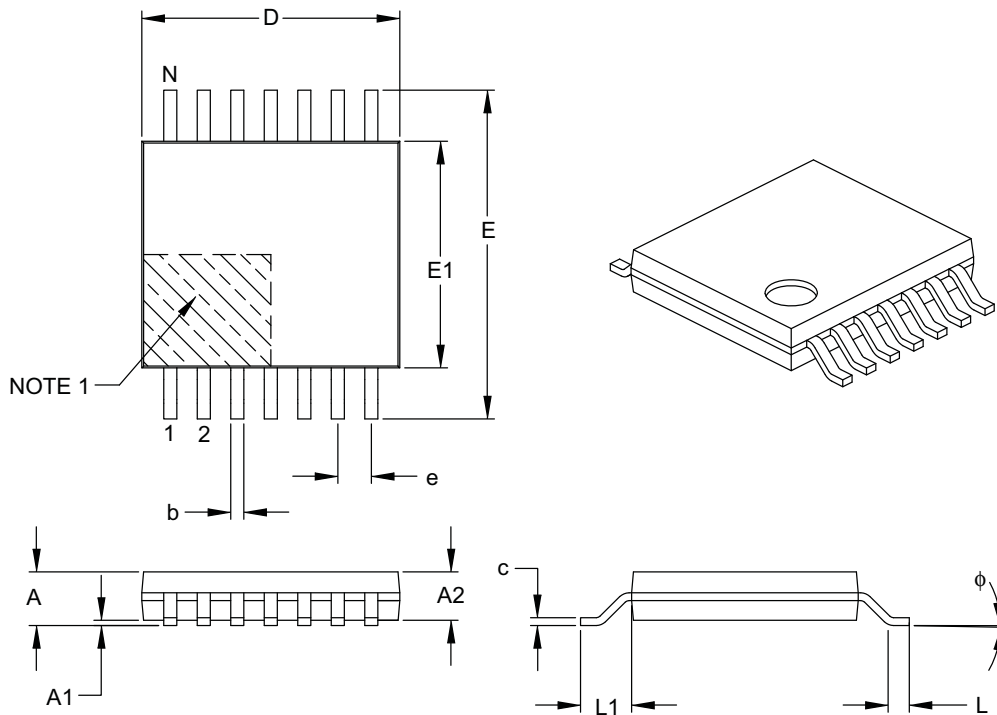

Dimension Limits	Units	MILLIMETERS		
		MIN	NOM	MAX
Number of Pins	N	14		
Pitch	e	0.65 BSC		
Overall Height	A	–	–	1.20
Molded Package Thickness	A2	0.80	1.00	1.05
Standoff	A1	0.05	–	0.15
Overall Width	E	6.40 BSC		
Molded Package Width	E1	4.30	4.40	4.50
Molded Package Length	D	4.90	5.00	5.10
Foot Length	L	0.45	0.60	0.75
Footprint	L1	1.00 REF		
Foot Angle	ϕ	0°	–	8°
Lead Thickness	c	0.09	–	0.20
Lead Width	b	0.19	–	0.30

Notes:

- Pin 1 visual index feature may vary, but must be located within the hatched area.
- Dimensions D and E1 do not include mold flash or protrusions. Mold flash or protrusions shall not exceed 0.15 mm per side.
- Dimensioning and tolerancing per ASME Y14.5M.

BSC: Basic Dimension. Theoretically exact value shown without tolerances.

REF: Reference Dimension, usually without tolerance, for information purposes only.

Microchip Technology Drawing C04-087B

14-Lead Plastic Thin Shrink Small Outline (ST) - 4.4 mm Body [TSSOP]

Note: For the most current package drawings, please see the Microchip Packaging Specification located at <http://www.microchip.com/packaging>

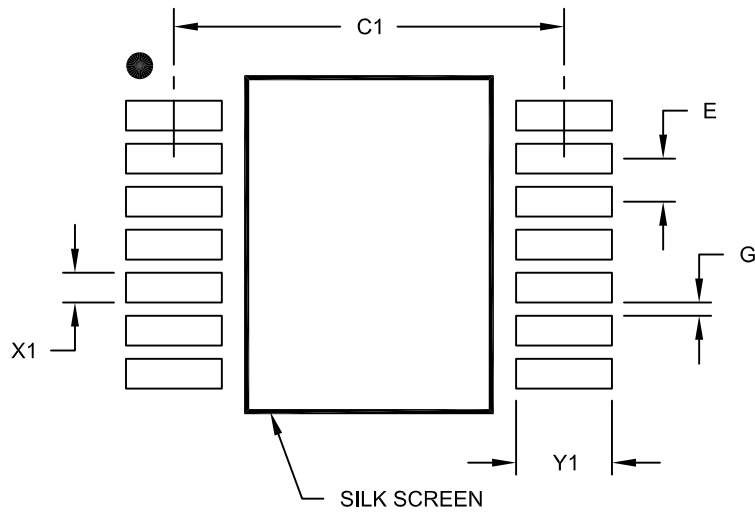

RECOMMENDED LAND PATTERN

Dimension Limits	Units	MILLIMETERS		
		MIN	NOM	MAX
Contact Pitch	E	0.65 BSC		
Contact Pad Spacing	C1		5.90	
Contact Pad Width (X28)	X1			0.45
Contact Pad Length (X28)	Y1			1.45
Distance Between Pads	G	0.20		

Notes:

1. Dimensioning and tolerancing per ASME Y14.5M

BSC: Basic Dimension. Theoretically exact value shown without tolerances.

Microchip Technology Drawing No. C04-2087A

MCP606/7/8/9

NOTES:

APPENDIX A: REVISION HISTORY

Revision F (September 2009)

The following is the list of modifications:

1. Corrected RL text in [Figure 2-22](#) in **Section 2.0 “Typical Performance Curves”**.
2. Corrected devices’ pins in [Table 3-1 \(Section 3.0 “Pin Descriptions”\)](#).
3. Updated **Section 6.0 “Packaging Information”**. Updated package outline drawings.

Revision E (March 2008)

The following is the list of modifications:

1. Increased maximum operating V_{DD} .
2. Added test circuits.
3. Updated performance curves.
4. Added [Figure 2-31](#).
5. Added **Section 4.1.1 “Phase Reversal”**, **Section 4.1.2 “Input Voltage and Current Limits”**, and **Section 4.1.3 “Normal Operation”**.
6. Updated **Section 5.0 “Design Aids”**
7. Updated **Section 6.0 “Packaging Information”**. Updated package outline drawings.

Revision D (February 2005)

The following is the list of modifications:

1. Added **Section 3.0 “Pin Descriptions”**.
2. Updated **Section 4.0 “Applications Information”**.
3. Added **Section 4.3 “Capacitive Loads”**
4. Updated **Section 5.0 “Design Aids”** to include FilterLab[®] and to point to the latest SPICE macro model.
5. Corrected and updated **Section 6.0 “Packaging Information”**.
6. Added **Appendix A: “Revision History”**.

Revision C (January 2001)

- Undocumented changes

Revision B (May 2000)

- Undocumented changes

Revision A (January 2000)

- Original Release of this Document.

MCP606/7/8/9

NOTES:

PRODUCT IDENTIFICATION SYSTEM

To order or obtain information, e.g., on pricing or delivery, refer to the factory or the listed sales office.

<u>PART NO.</u>	<u>X</u>	<u>/XX</u>	
Device	Temperature Range	Package	
Device	MCP606 = Single Op Amp MCP606T = Single Op Amp Tape and Reel (SOIC, TSSOP)		
	MCP607 = Dual Op Amp MCP607T = Dual Op Amp Tape and Reel (SOIC, TSSOP)		
	MCP608 = Single Op Amp with \overline{CS} MCP608T = Single Op Amp with \overline{CS} Tape and Reel (SOIC, TSSOP)		
	MCP609 = Quad Op Amp MCP609T = Quad Op Amp Tape and Reel (SOIC, TSSOP)		
Temperature Range	I = -40°C to +85°C		
Package	OT = Plastic SOT-23, 5-lead P = Plastic DIP (300 mil Body), 8-lead, 14-lead SN = Plastic SOIC (3.90 mm body), 8-lead SL = Plastic SOIC (3.90 mm body), 14-lead ST = Plastic TSSOP, 8-lead, 14-lead		

Examples:	
a) MCP606-I/P:	Industrial Temperature, 8LD PDIP package.
b) MCP606-I/SN:	Industrial Temperature, 8LD SOIC package.
c) MCP606T-I/SN:	Tape and Reel, Industrial Temperature, 8LD SOIC package.
d) MCP606-I/ST:	Industrial Temperature, 8LD TSSOP package.
e) MCP606T-I/OT:	Tape and Reel, Industrial Temperature, 5LD SOT-23 package.
a) MCP607-I/P:	Industrial Temperature, 8LD PDIP package.
b) MCP607T-I/SN:	Tape and Reel, Industrial Temperature, 8LD SOIC package.
a) MCP608-I/SN:	Industrial Temperature, 8LD SOIC package.
b) MCP608T-I/SN:	Tape and Reel, Industrial Temperature, 8LD SOIC package.
a) MCP609-I/P:	Industrial Temperature, 14LD PDIP package.
b) MCP609T-I/SL:	Tape and Reel, Industrial Temperature, 14LD SOIC package.

MCP606/7/8/9

NOTES:

Note the following details of the code protection feature on Microchip devices:

- Microchip products meet the specification contained in their particular Microchip Data Sheet.
- Microchip believes that its family of products is one of the most secure families of its kind on the market today, when used in the intended manner and under normal conditions.
- There are dishonest and possibly illegal methods used to breach the code protection feature. All of these methods, to our knowledge, require using the Microchip products in a manner outside the operating specifications contained in Microchip's Data Sheets. Most likely, the person doing so is engaged in theft of intellectual property.
- Microchip is willing to work with the customer who is concerned about the integrity of their code.
- Neither Microchip nor any other semiconductor manufacturer can guarantee the security of their code. Code protection does not mean that we are guaranteeing the product as “unbreakable.”

Code protection is constantly evolving. We at Microchip are committed to continuously improving the code protection features of our products. Attempts to break Microchip's code protection feature may be a violation of the Digital Millennium Copyright Act. If such acts allow unauthorized access to your software or other copyrighted work, you may have a right to sue for relief under that Act.

Information contained in this publication regarding device applications and the like is provided only for your convenience and may be superseded by updates. It is your responsibility to ensure that your application meets with your specifications. MICROCHIP MAKES NO REPRESENTATIONS OR WARRANTIES OF ANY KIND WHETHER EXPRESS OR IMPLIED, WRITTEN OR ORAL, STATUTORY OR OTHERWISE, RELATED TO THE INFORMATION, INCLUDING BUT NOT LIMITED TO ITS CONDITION, QUALITY, PERFORMANCE, MERCHANTABILITY OR FITNESS FOR PURPOSE. Microchip disclaims all liability arising from this information and its use. Use of Microchip devices in life support and/or safety applications is entirely at the buyer's risk, and the buyer agrees to defend, indemnify and hold harmless Microchip from any and all damages, claims, suits, or expenses resulting from such use. No licenses are conveyed, implicitly or otherwise, under any Microchip intellectual property rights.

Trademarks

The Microchip name and logo, the Microchip logo, dsPIC, KEELOQ, KEELOQ logo, MPLAB, PIC, PICmicro, PICSTART, rfPIC and UNI/O are registered trademarks of Microchip Technology Incorporated in the U.S.A. and other countries.

FilterLab, Hampshire, HI-TECH C, Linear Active Thermistor, MXDEV, MXLAB, SEEVAL and The Embedded Control Solutions Company are registered trademarks of Microchip Technology Incorporated in the U.S.A.

Analog-for-the-Digital Age, Application Maestro, CodeGuard, dsPICDEM, dsPICDEM.net, dsPICworks, dsSPEAK, ECAN, ECONOMONITOR, FanSense, HI-TIDE, In-Circuit Serial Programming, ICSP, Mindi, MiWi, MPASM, MPLAB Certified logo, MPLIB, MPLINK, mTouch, Octopus, Omniscient Code Generation, PICC, PICC-18, PICDEM, PICDEM.net, PICkit, PICtail, PIC³² logo, REAL ICE, rLAB, Select Mode, Total Endurance, TSHARC, UniWinDriver, WiperLock and ZENA are trademarks of Microchip Technology Incorporated in the U.S.A. and other countries.

SQTP is a service mark of Microchip Technology Incorporated in the U.S.A.

All other trademarks mentioned herein are property of their respective companies.

© 2009, Microchip Technology Incorporated, Printed in the U.S.A., All Rights Reserved.

 Printed on recycled paper.

**QUALITY MANAGEMENT SYSTEM
CERTIFIED BY DNV
== ISO/TS 16949:2002 ==**

Microchip received ISO/TS-16949:2002 certification for its worldwide headquarters, design and wafer fabrication facilities in Chandler and Tempe, Arizona; Gresham, Oregon and design centers in California and India. The Company's quality system processes and procedures are for its PIC[®] MCUs and dsPIC[®] DSCs, KEELOQ[®] code hopping devices, Serial EEPROMs, microperipherals, nonvolatile memory and analog products. In addition, Microchip's quality system for the design and manufacture of development systems is ISO 9001:2000 certified.



WORLDWIDE SALES AND SERVICE

AMERICAS

Corporate Office
2355 West Chandler Blvd.
Chandler, AZ 85224-6199
Tel: 480-792-7200
Fax: 480-792-7277
Technical Support:
<http://support.microchip.com>
Web Address:
www.microchip.com

Atlanta
Duluth, GA
Tel: 678-957-9614
Fax: 678-957-1455

Boston
Westborough, MA
Tel: 774-760-0087
Fax: 774-760-0088

Chicago
Itasca, IL
Tel: 630-285-0071
Fax: 630-285-0075

Cleveland
Independence, OH
Tel: 216-447-0464
Fax: 216-447-0643

Dallas
Addison, TX
Tel: 972-818-7423
Fax: 972-818-2924

Detroit
Farmington Hills, MI
Tel: 248-538-2250
Fax: 248-538-2260

Kokomo
Kokomo, IN
Tel: 765-864-8360
Fax: 765-864-8387

Los Angeles
Mission Viejo, CA
Tel: 949-462-9523
Fax: 949-462-9608

Santa Clara
Santa Clara, CA
Tel: 408-961-6444
Fax: 408-961-6445

Toronto
Mississauga, Ontario,
Canada
Tel: 905-673-0699
Fax: 905-673-6509

ASIA/PACIFIC

Asia Pacific Office
Suites 3707-14, 37th Floor
Tower 6, The Gateway
Harbour City, Kowloon
Hong Kong
Tel: 852-2401-1200
Fax: 852-2401-3431

Australia - Sydney
Tel: 61-2-9868-6733
Fax: 61-2-9868-6755

China - Beijing
Tel: 86-10-8528-2100
Fax: 86-10-8528-2104

China - Chengdu
Tel: 86-28-8665-5511
Fax: 86-28-8665-7889

China - Hong Kong SAR
Tel: 852-2401-1200
Fax: 852-2401-3431

China - Nanjing
Tel: 86-25-8473-2460
Fax: 86-25-8473-2470

China - Qingdao
Tel: 86-532-8502-7355
Fax: 86-532-8502-7205

China - Shanghai
Tel: 86-21-5407-5533
Fax: 86-21-5407-5066

China - Shenyang
Tel: 86-24-2334-2829
Fax: 86-24-2334-2393

China - Shenzhen
Tel: 86-755-8203-2660
Fax: 86-755-8203-1760

China - Wuhan
Tel: 86-27-5980-5300
Fax: 86-27-5980-5118

China - Xiamen
Tel: 86-592-2388138
Fax: 86-592-2388130

China - Xian
Tel: 86-29-8833-7252
Fax: 86-29-8833-7256

China - Zhuhai
Tel: 86-756-3210040
Fax: 86-756-3210049

ASIA/PACIFIC

India - Bangalore
Tel: 91-80-3090-4444
Fax: 91-80-3090-4080

India - New Delhi
Tel: 91-11-4160-8631
Fax: 91-11-4160-8632

India - Pune
Tel: 91-20-2566-1512
Fax: 91-20-2566-1513

Japan - Yokohama
Tel: 81-45-471- 6166
Fax: 81-45-471-6122

Korea - Daegu
Tel: 82-53-744-4301
Fax: 82-53-744-4302

Korea - Seoul
Tel: 82-2-554-7200
Fax: 82-2-558-5932 or
82-2-558-5934

Malaysia - Kuala Lumpur
Tel: 60-3-6201-9857
Fax: 60-3-6201-9859

Malaysia - Penang
Tel: 60-4-227-8870
Fax: 60-4-227-4068

Philippines - Manila
Tel: 63-2-634-9065
Fax: 63-2-634-9069

Singapore
Tel: 65-6334-8870
Fax: 65-6334-8850

Taiwan - Hsin Chu
Tel: 886-3-6578-300
Fax: 886-3-6578-370

Taiwan - Kaohsiung
Tel: 886-7-536-4818
Fax: 886-7-536-4803

Taiwan - Taipei
Tel: 886-2-2500-6610
Fax: 886-2-2508-0102

Thailand - Bangkok
Tel: 66-2-694-1351
Fax: 66-2-694-1350

EUROPE

Austria - Wels
Tel: 43-7242-2244-39
Fax: 43-7242-2244-393

Denmark - Copenhagen
Tel: 45-4450-2828
Fax: 45-4485-2829

France - Paris
Tel: 33-1-69-53-63-20
Fax: 33-1-69-30-90-79

Germany - Munich
Tel: 49-89-627-144-0
Fax: 49-89-627-144-44

Italy - Milan
Tel: 39-0331-742611
Fax: 39-0331-466781

Netherlands - Drunen
Tel: 31-416-690399
Fax: 31-416-690340

Spain - Madrid
Tel: 34-91-708-08-90
Fax: 34-91-708-08-91

UK - Wokingham
Tel: 44-118-921-5869
Fax: 44-118-921-5820

03/26/09

Looking for pricing, stock, or lifecycle information?

Click below to explore more details on WIN SOURCE:

- ⊖ [View MCP606-I/SN on WIN SOURCE](#)
- ⊖ [Microchip Technology Information](#)

Optimize Your Supply Chain with WIN SOURCE Solutions

- ✓ Global Sourcing Solution
- ✓ Obsolete Management
- ✓ Cost Control Management
- ✓ Shortage Management
- ✓ Alternative Solution
- ✓ Excess Inventory Management