



MCP2155

IrDA[®] Standard Protocol Stack Controller Supporting DCE Applications

Features

- Implements the IrDA[®] standard including:
 - IrLAP
 - IrLMP
 - IAS
 - TinyTP
 - IrCOMM (9-wire "cooked" service class)
- Provides IrDA standard physical signal layer support including:
 - Bi-directional communication
 - CRC implementation
 - Data communication rates up to 115.2 kbaud
- Includes UART to IrDA standard bit encoder/decoder functionality:
 - Easily interfaces to industry standard UARTs and infrared transceivers
- UART interface for connecting to Data Communicating Equipment (DCE) systems
- Transmit/Receive formats (bit width) supported:
 - 1.63 μ s
- Hardware baud rate selection for UART
 - 9.6 kbaud
 - 19.2 kbaud
 - 57.6 kbaud
 - 115.2 kbaud
- Infrared baud rates supported
 - 9.6 kbaud
 - 19.2 kbaud
 - 38.4 kbaud
 - 57.6 kbaud
 - 115.2 kbaud
- 64 Byte Data Packet Size
- Programmable Device ID String
- Operates as Secondary Device

CMOS Technology

- Low-power, high-speed CMOS technology
- Fully static design
- Low voltage operation
- Industrial temperature range
- Low power consumption
 - < 1 mA @ 3.3V, 11.0592 MHz (typical)
 - 3 mA typical @ 5.0V when disabled

Pin Diagrams

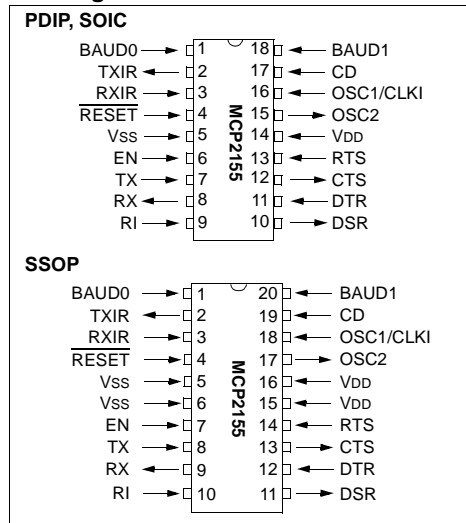

Block Diagram

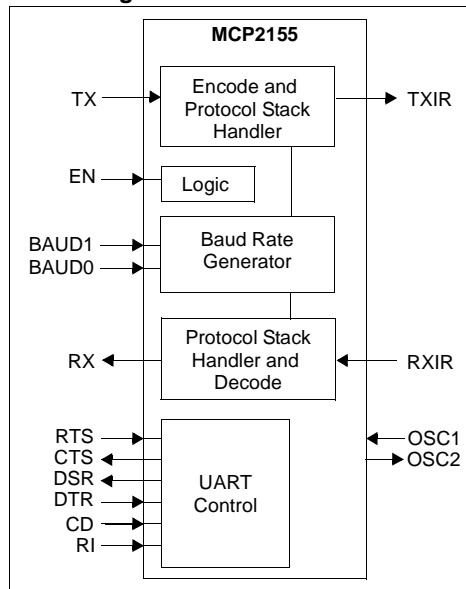



MCP2155

NOTES:

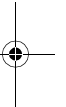
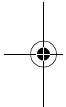

MCP2155

1.0 DEVICE OVERVIEW

This document contains device specific information for the following device:

- MCP2155

The MCP2155 is a cost effective, low pin count (18-pin), easy to use device for implementing IrDA standard wireless connectivity. The MCP2155 handles for the IrDA standard protocol “stack” plus bit encoding/decoding. The MCP2155 operates in Data Communication Equipment (DCE) applications and sits between a UART and an infrared optical transceiver.

The Serial interface baud rates are user selectable to one of four IrDA standard baud rates between 9600 baud and 115.2 kbaud (9600, 19200, 57600, 115200). The IR baud rates are user selectable to one of five IrDA standard baud rates between 9600 baud and 115.2 kbaud (9600, 19200, 38400, 57600, 115200). The serial interface baud rate will be specified by the BAUD1:BAUD0 pins, while the IR baud rate is specified by the Host Controller. This means that the baud rates do not need to be the same.

The MCP2155 encodes an asynchronous serial data stream, converting each data bit to the corresponding infrared (IR) formatted pulse. IR pulses that are received are decoded, and then handled by the protocol handler state machine. The protocol handler will then send the appropriate data bytes to the host controller in UART formatted serial data.

The MCP2155 supports “point-to-point” applications. That is one Primary device and one Secondary device. The MCP2155 is a secondary device and does not support “multi-point” applications.

Sending data using IR light requires some hardware and the use of specialized communications protocols. These protocols and hardware requirements are described in detail by the IrDA standard specifications. The encoding/decoding functionality of the MCP2155 is designed to be compatible with the physical layer component of the IrDA standard. This part of the standard is often referred to as “IrPHY”.

The complete IrDA standard specifications are available for download from the IrDA website (www.IrDA.org).

MCP2155

1.1 Applications

The MCP2155 IrDA standard protocol stack controller supporting the IrDA standard for IrCOMM 9-wire “cooked” service class which enables embedded system designers the easiest way to implement IrDA standard wireless connectivity. Figure 1-1 shows a typical application block diagram. Table 1-2 shows the pin definitions.

TABLE 1-1: OVERVIEW OF FEATURES

Features	MCP2155
Serial Communications:	UART, IR
Baud Rate Selection:	Hardware
Low Power Mode:	Yes
Resets (and Delays):	RESET, POR (PWRT and OST)
Packages:	18-pin DIP, SOIC, 20-pin SSOP

Infrared communication is a wireless two-way data connection using infrared light generated by low-cost transceiver signaling technology. This provides reliable communication between two devices.

Infrared technology offers:

- Universal standard for connecting portable computing devices
- Easy, effortless implementation
- Economical alternative to other connectivity solutions
- Reliable, high speed connection
- Safe to use in any environment; can even be used during air travel
- Eliminates the hassle of cables
- Allows PC's and other electronic device's (such as PDA's, cell phones,) to communicate with each other
- Enhances mobility by allowing users to easily connect

The MCP2155 allows the easy addition of IrDA standard wireless connectivity to any embedded application that uses serial data. Figure 1-1 shows typical implementation of the MCP2155 in an embedded system.

The IrDA protocols for printer support are not included in the IrCOMM 9-wire “cooked” service class.

FIGURE 1-1: SYSTEM BLOCK DIAGRAM

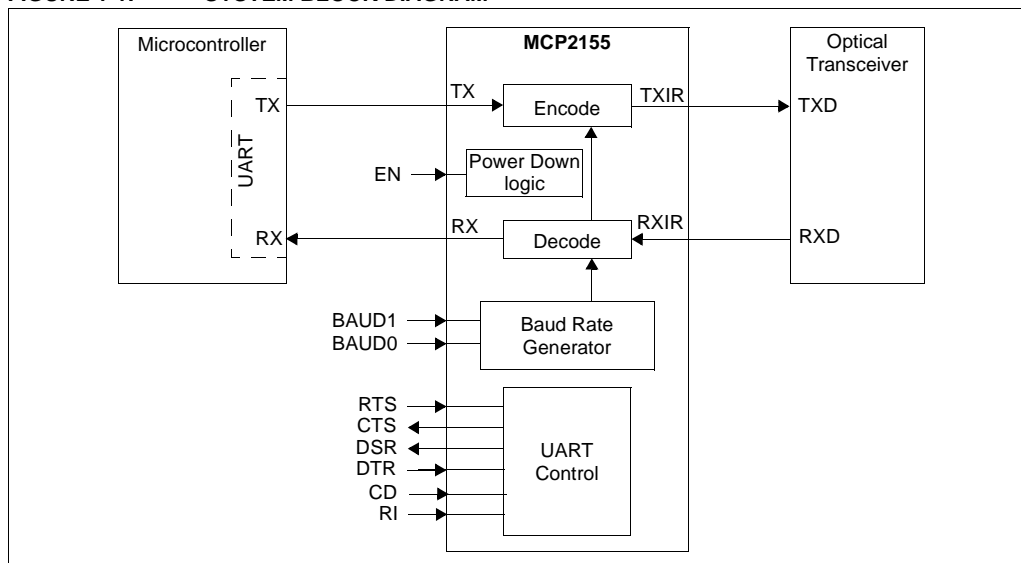

MCP2155

TABLE 1-2: PIN DESCRIPTION

Pin Name	Pin Number			Pin Type	Buffer Type	Description
	PDIP	SOIC	SSOP			
BAUD0	1	1	1	I	ST	BAUD1:BAUD0 specify the baud rate of the device. For more information see Section 2.5.1 .
TXIR	2	2	2	O	—	Asynchronous transmit to Infrared transceiver.
RXIR	3	3	3	I	ST	Asynchronous receive from Infrared transceiver.
RESET	4	4	4	I	ST	Resets the device.
Vss	5	5	5, 6	—	P	Ground reference for logic and I/O pins.
EN	6	6	7	I	TTL	Device enable. 1 = Device is enabled 0 = Device is disabled (low power)
TX	7	7	8	I	TTL	Asynchronous receive; from Host Controller UART.
RX	8	8	9	O	—	Asynchronous transmit; to Host Controller UART.
RI	9	9	10	I	TTL	Ring Indicator. The state of this bit is communicated to the IrDA Primary Device. 1 = No Ring Indicate Present 0 = Ring Indicate Present
DSR	10	10	11	O	—	Data Set Ready. Indicates that the MCP2155 has established a valid link with a Primary Device. This signal is locally emulated and not related to the DTR bit of the IrDA Primary Device. 1 = An IR link has not been established (No IR Link) 0 = An IR link has been established (IR Link)
DTR	11	11	12	I	TTL	Data Terminal Ready. Indicates that the Embedded device connected to the MCP2155 is ready for IR data. The state of this bit is communicated to the IrDA Primary Device, via the IrDA bit carried by IrCOMM. 1 = Embedded device not ready 0 = Embedded device ready At device power-up, this signal is used with RTS to enter device ID programming. 1= Enter Device ID programming mode (if RTS is cleared) 0= Do not enter Device ID programming mode
CTS	12	12	13	O	—	Clear to Send. Indicates that the MCP2155 is ready to receive data form the Host Controller. This signal is locally emulated and not related to the CTS/RTS bit of the IrDA Primary Device. 1 = Host Controller should not send data 0 = Host Controller may send data
RTS	13	13	14	I	TTL	Request to Send. Indicates that the Host Controller is ready to receive data from the MCP2155. This signal is locally emulated and not related to the CTS/RTS bit of the IrDA Primary Device. 1 = Host Controller not ready to receive data 0 = Host Controller ready to receive data At device power-up, this signal is used with CTS to enter device ID programming. 1= Do not enter Device ID programming mode 0= Enter Device ID programming mode (if DTR is set)
VDD	14	14	15, 16	—	P	Positive supply for logic and I/O pins.
OSC2	15	15	17	O	—	Oscillator crystal output.
OSC1/CLKIN	16	16	18	I	CMOS	Oscillator crystal input/external clock source input.

Legend: TTL = TTL compatible input
I = Input
P = Power

ST = Schmitt Trigger input with CMOS levels
O = Output
CMOS = CMOS compatible input

MCP2155

Pin Name	Pin Number			Pin Type	Buffer Type	Description
	PDIP	SOIC	SSOP			
CD	17	17	19	I	ST	Carrier Detect. The state of this bit is communicated to the IrDA Primary Device. 1 = No Carrier Present 0 = Carrier Present
BAUD1	18	18	20	I	ST	BAUD1:BAUD0 specify the baud rate of the device. For more information see Section 2.5.1 .

Legend: TTL = TTL compatible input ST = Schmitt Trigger input with CMOS levels
 I = Input O = Output
 P = Power CMOS = CMOS compatible input

1.1.1 SIGNAL DIRECTIONS

[Table 1-3](#) shows the direction of the MCP2155 signals. The MCP2155 is designed for use in Data Communication Equipment (DCE) applications.

TABLE 1-3: MCP2155 SIGNAL DIRECTION

DB-9 Pin #	Signal	Direction	Comment
1	CD	HC → MCP2155	Carrier Detect
2	RX	MCP2155 → HC	Received Data
3	TX	HC → MCP2155	Transmit Data
4	DTR	HC → MCP2155	Data Terminal Ready
5	GND	—	Ground
6	DSR	MCP2155 → HC	Data Set Ready
7	RTS	HC → MCP2155	Request to Send
8	CTS	MCP2155 → HC	Clear to Send
9	RI	HC → MCP2155	Ring Indicator

Legend: HC = Host Controller

MCP2155

2.0 DEVICE OPERATION

The MCP2155 is a cost effective, low pin count (18-pin), easy to use device for implementing IrDA standard wireless connectivity. The MCP2155 provides support for the IrDA standard protocol "stack" plus bit encoding/decoding. The Serial interface and IR baud rates are independantly selectable.

2.1 Power-up

Any time that the device is powered up ([parameter D003](#)), the Power-up timer delay ([parameter 33](#)) occurs, followed by an Oscillator Start-up Timer (OST) delay ([parameter 32](#)). After these two delays complete, communication with the device may be initiated. This communication is from both the infrared transceiver's side as well as the controller's UART interface.

2.2 Device Reset

The MCP2155 is forced into the reset state when the RESET pin is in the low state. After the RESET pin is brought to a high state, the Device Reset sequence occurs. Once the sequence completes, functional operation begins.

2.3 Clock Source

The MCP2155 requires a clock source to operate. The frequency of this clock is 11.0592 MHz (electrical specification [parameter 1A](#)). This clock can be supplied by either a crystal/resonator or as an external clock input.

2.3.1 CRYSTAL OSCILLATOR / CERAMIC RESONATORS

A crystal or ceramic resonator can be connected to the OSC1 and OSC2 pins to establish oscillation ([Figure 2-1](#)). The MCP2155 oscillator design requires the use of a parallel cut crystal. Use of a series cut crystal may give a frequency out of the crystal manufacturer's specifications.

FIGURE 2-1: CRYSTAL OPERATION (OR CERAMIC RESONATOR)

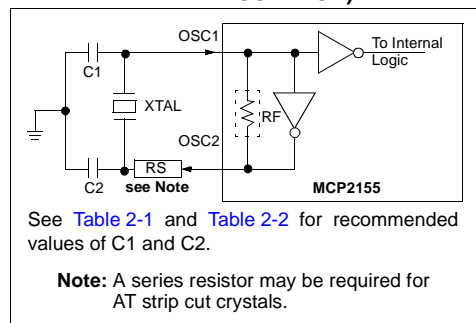

TABLE 2-1: CAPACITOR SELECTION FOR CERAMIC RESONATORS

Freq	OSC1 (C1)	OSC2 (C2)
11.0592 MHz	10 - 22 pF	10 - 22 pF

Higher capacitance increases the stability of the oscillator but also increases the start-up time. These values are for design guidance only. Since each resonator has its own characteristics, the user should consult the resonator manufacturer for appropriate values of external components.

TABLE 2-2: CAPACITOR SELECTION FOR CRYSTAL OSCILLATOR

Freq	OSC1 (C1)	OSC2 (C2)
11.0592 MHz	15 - 30 pF	15 - 30 pF

Higher capacitance increases the stability of the oscillator but also increases the start-up time. These values are for design guidance only. Rs may be required to avoid overdriving crystals with low drive level specification. Since each crystal has its own characteristics, the user should consult the crystal manufacturer for appropriate values of external components.

2.3.2 EXTERNAL CLOCK IN

For applications where a clock is already available elsewhere, users may directly drive the MCP2155 provided that this external clock source meets the AC/DC timing requirements listed in [Section 4.3](#). [Figure 2-2](#) below shows how an external clock circuit should be configured.

FIGURE 2-2: EXTERNAL CLOCK INPUT OPERATION

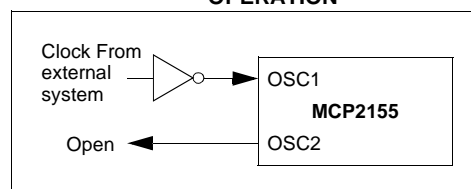

MCP2155

2.4 Bit Clock

The device crystal is used to derive the communication bit clock (BITCLK). There are 16 BITCLKs for each bit time. The BITCLKs are used for the generation of the start bit and the eight data bits. The stop bit uses the BITCLK when the data is transmitted (not for reception).

This clock is a fixed frequency, and has minimal variation in frequency (specified by crystal manufacturer).

2.5 UART Interface

The UART interface communicates with the "controller". This interface is a half duplex interface, meaning that the system is either transmitting or receiving, but not both at the same time.

2.5.1 BAUD RATE

The baud rate for the MCP2155 serial port (the TX and RX pins) is configured by the state of the BAUD1 and BAUD0 pins. These two device pins are used to select the baud rate that the MCP2155 will transmit and receive serial data (not IR data). [Table 2-3](#) shows the baud rate configurations.

TABLE 2-3: SERIAL BAUD RATE SELECTION VS. FREQUENCY

BAUD1:BAUD0	Baud Rate @ 11.0592 MHz	Bit Rate
00	9600	$F_{osc} / 1152$
01	19200	$F_{osc} / 576$
10	57600	$F_{osc} / 192$
11	115200	$F_{osc} / 96$

2.5.2 TRANSMITTING

When the controller sends serial data to the MCP2155, the controller's baud rate is required to match the baud rate of the MCP2155's serial port.

2.5.3 RECEIVING

When the controller receives serial data from the MCP2155, the controller's baud rate is required to match the baud rate of the MCP2155's serial port.

MCP2155

2.6 Modulation

The data that the MCP2155 UART received (on the TX pin) that needs to be transmitted (on the TXIR pin), will need to be modulated. This modulated signal drives the IR transceiver module. Figure 2-3 shows the encoding of the modulated signal.

Note: The signal on the TXIR pin does not actually line up in time with the bit value that was transmitted on the TX pin as shown in Figure 2-3. The TX bit value is shown to represent the value to be transmitted on the TXIR pin.

Each bit time is comprised of 16-bit clocks. If the value to be transmitted (as determined by the TX pin) is a logic low, then the TXIR pin will output a low level for 7-bit clock cycles, a logic high level for 3-bit clock cycles or a minimum of 1.6 μ S (see parameter IR121), and then the remaining 6-bit clock cycles (or difference up to the 16-bit clock time) will be low. If the value to transmit is a logic high, then the TXIR pin will output a low level for the entire 16-bit clock cycles.

2.7 Demodulation

The modulated signal (data) from the IR transceiver module (on RXIR pin) needs to be demodulated to form the received data (on RX pin). After demodulation of the data byte occurs, the data that is received is transmitted by the MCP2155 UART (on the RX pin). Figure 2-4 shows the decoding of the modulated signal.

Note: The signal on the RX pin does not actually line up in time with the bit value that was received on the RXIR pin as shown in Figure 2-4. The RXIR bit value is shown to represent the value to be transmitted on the RX pin.

Each bit time is comprised of 16 bit clocks. If the value to be received is a logic low, then the RXIR pin will be a low level for the first 3-bit clock cycles or a minimum of 1.6 μ s, and then the remaining 13-bit clock cycles (or difference up to the 16-bit clock time) will be high. If the value to be received is a logic high, then the RXIR pin will be a high level for the entire 16-bit clock cycles. The level on the RX pin will be in the appropriate state for the entire 16 clock cycles.

FIGURE 2-3: ENCODING

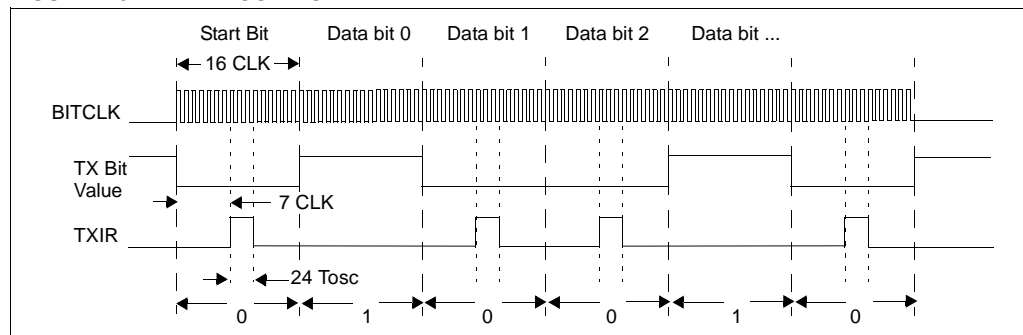
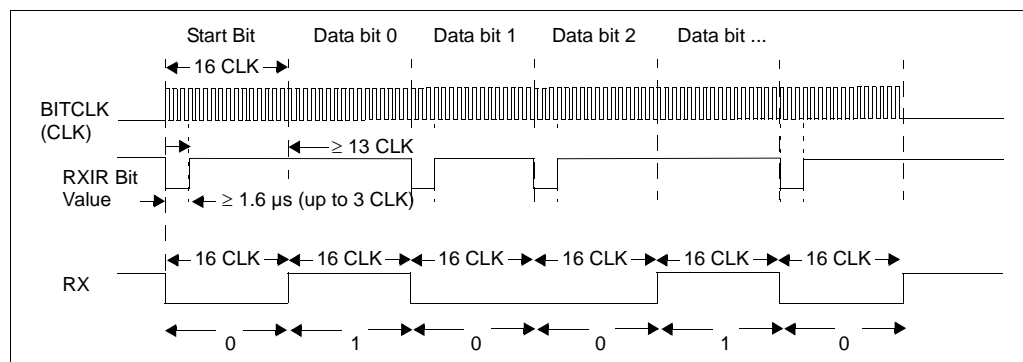

FIGURE 2-4: DECODING



MCP2155

2.8 Minimizing Power

The device can be placed in a low power mode by disabling the device (holding the EN pin at the low state). The internal state machine is monitoring this pin for a low level, and once this is detected the device is disabled and enters into a low power state.

2.8.1 RETURNING TO DEVICE OPERATION

When disabled, the device is in a low power state. When the EN pin is brought to a high level, the device will return to the operating mode. The device requires a delay of 1024 T_{osc} before data may be transmitted or received.

2.9 Network Layering Reference Model

Figure 2-5 shows the ISO Network Layering Reference Model. The shaded areas are implemented by the MCP2155, the cross-hatched area is implemented by an infrared transceiver, and the unshaded areas need to be implemented by the Host controller.

FIGURE 2-5: ISO REFERENCE LAYER MODEL

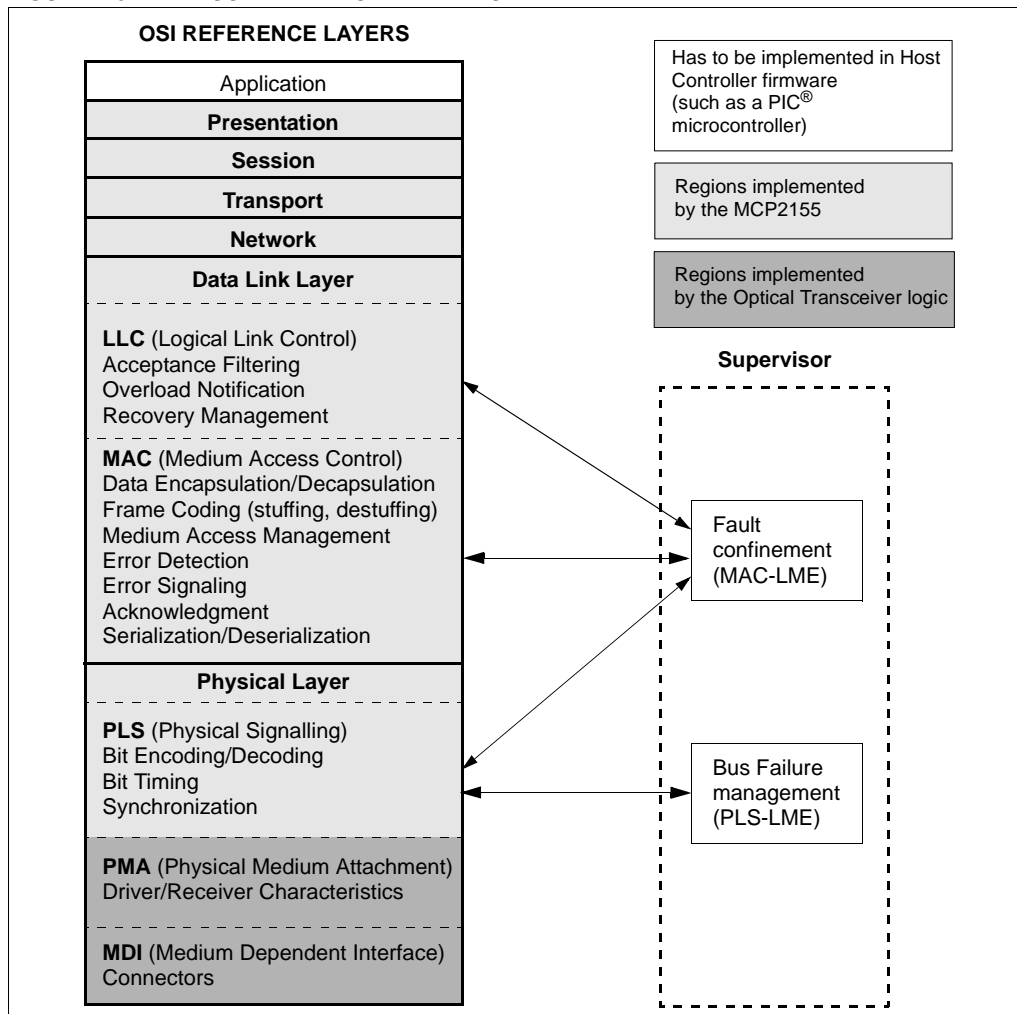

MCP2155

The IrDA standard specifies the following protocols:

- Physical Signaling Layer (PHY)
- Link Access Protocol (IrLAP)
- Link Management Protocol/Information Access Service (IrLMP/IAS)

The IrDA data lists optional protocols. These are:

- Tiny TP
- IrTran-P
- IrOBEX
- IrLAN
- IrCOMM
- IrMC
- IrDA Lite

Figure 2-6 shows the IrDA data protocol stack and which components are implemented by the MCP2155.

FIGURE 2-6: IRDA DATA - PROTOCOL STACKS

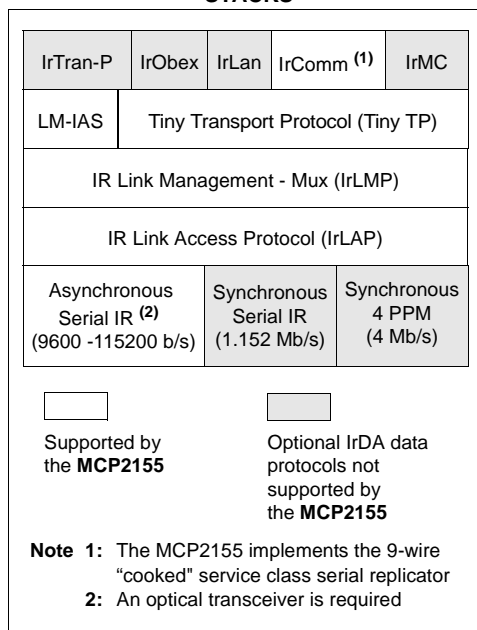

2.9.1 IrDA DATA PROTOCOLS SUPPORTED BY MCP2155

The MCP2155 supports these required IrDA standard protocols:

- Physical Signaling Layer (PHY)
- Link Access Protocol (IrLAP)
- Link Management Protocol/Information Access Service (IrLMP/IAS)

The MCP2155 also supports some of the optional protocols for IrDA data. The optional protocols that the MCP2155 implements are:

- Tiny TP
- IrCOMM

2.9.1.1 Physical Signal Layer (PHY)

The MCP2155 provides the following Physical Signal Layer specification support:

- Bi-directional communication
- Data Packets are protected by a CRC
 - 16-bit CRC for speeds up to 115.2 kbaud
- Data Communication Rate
 - 9600 baud minimum data rate (with primary speed/cost steps of 115.2 kbaud)

The following Physical Layer Specification is dependant on the optical transceiver logic used in the application. The specification states:

- Communication Range, which sets the end user expectation for discovery, recognition and performance
 - Continuous operation from contact to at least 1 meter (typically 2 meters can be reached)
 - A low power specification reduces the objective for operation from contact to at least 20 cm (low power and low power) or 30 cm (low power and standard power).

MCP2155

2.9.1.2 IrLAP

The MCP2155 supports the IrLAP protocol. The IrLAP protocol provides:

- Management of communication processes on the link between devices.
- A device-to-device connection for the reliable, ordered transfer of data.
- Device discover procedures.
- Hidden node handling. (Not supported by MCP2155)

Figure 2-7 identifies the key parts and hierarchy of the IrDA protocols. The bottom layer is the Physical layer, IrPHY. This is the part that converts the serial data to and from pulses of IR light. IR transceivers can't transmit and receive at the same time. The receiver has to wait for the transmitter to finish sending. This is sometimes referred to as a "Half-Duplex" connection. The IR Link Access Protocol (IrLAP) provides the structure for packets or "frames" of data to emulate data that would normally be free to stream back and forth.

FIGURE 2-7: IRDA STANDARD PROTOCOL LAYERS

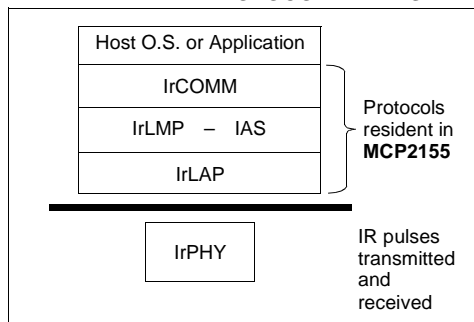

Figure 2-8 shows how the IrLAP frame is organized. The frame is preceded by some number of Beginning of Frame characters (BOFs). The value of the BOF is generally 0xC0, but 0xFF may be used if the last BOF character is a 0xC0. The purpose of multiple BOFs is to give the other station some warning that a frame is coming.

The IrLAP frame begins with an address byte ("A" field), then a control byte ("C" field). The control byte is used to differentiate between different types of frames and is also used to count frames. Frames can carry status, data, or commands. The IrLAP protocol has a command syntax of its own, and these commands are part of the control byte. Lastly, IrLAP frames carry data. This data is the information or "I" field. The integrity of the frame is ensured with a 16-bit CRC, referred to as the Frame Check Sequence (FCS). The 16-bit CRC value is transmitted LSB first. The end of the frame is marked with an EOF character which is always a 0xC1. The frame structure described here is used for all versions of IrDA protocols used for serial wire replacement for speeds up to 115.2 kbaud.

Note 1: Another IrDA standard which is entering general usage is IR Object Exchange (IrOBEX). This standard is not used for serial connection emulation.

2: IrDA communication standards faster than 115.2 kbaud use a different CRC method and physical layer.

FIGURE 2-8: IRLAP FRAME

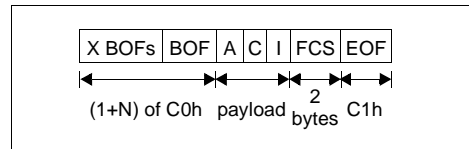

In addition to defining the frame structure, IrLAP provides the "housekeeping" function of opening and closing connections, and maintaining connections once they're open. The critical parameters that determine the performance of the link are part of this function. These parameters control how many BOFs are used, identify the speed of the link, how fast either party may change from receiving to transmitting, etc. IrLAP has the responsibility of negotiating these parameters to the highest common set so that both sides can communicate as fast and as reliably as possible.

MCP2155

2.9.1.3 IrLMP

The MCP2155 implements the IrLMP protocol. The IrLMP protocol provides:

- Multiplexing of the IrLAP layer. This allows multiple channels above an IrLAP connection
- Protocol and service discovery. This is via the Information Access Service (IAS)

When two devices that contain the IrDA standard feature are connected, there is generally one device that has something to do, and the other device has the resource to do it. For example, a laptop may have a job to print and an IrDA standard compatible printer has the resources to print it. In IrDA standard terminology, the laptop is a Primary device and the printer is the Secondary device. When these two devices connect, the Primary device must determine the capabilities of the Secondary device to determine if the Secondary device is capable of doing the job. This determination is made by the Primary device asking the Secondary device a series of questions. Depending on the answers to these questions the Primary device may or may not elect to connect to the Secondary device.

The queries from the Primary device are carried to the Secondary device using IrLMP. The responses to these queries can be found in the Information Access Service (IAS) of the Secondary device. The IAS is a list of the resources of the Secondary device. The Primary device compares the IAS responses with its requirements and then makes the decision if a connection should be made.

The MCP2155 identifies itself to the Primary device as a modem.

Note: The MCP2155 identifies itself as a modem to ensure that it is identified as a serial device with a limited amount of memory.

2.9.1.4 Link Management - Information Access Service (LM-IAS)

The MCP2155 implements the LM-IAS. Each LM-IAS entity maintains an information data base to provide:

- Information on services for other devices that contain the IrDA standard feature (Discovery)
- Information on services for the device itself
- Remote accessing of another device's information base

This is required so that clients on a remote device can find configuration information needed to access a service.

2.9.1.5 Tiny TP

Tiny TP provides the flow control on IrLMP connections. An optional service of Segmentation and Reassembly can be handled.

2.9.1.6 IrCOMM

IrCOMM provides the method to support serial and parallel port emulation. This is useful for legacy COM applications, such as printers and modem devices.

The IrCOMM standard is simply a syntax that allows the Primary device to consider the Secondary device as a serial device. IrCOMM allows for emulation of serial or parallel (printer) connections of various capabilities. The MCP2155 supports the 9-wire "cooked" service class of IrCOMM. Other service classes supported by IrCOMM are shown in [Figure 2-9](#).

FIGURE 2-9: IRCOMM SERVICE CLASSES

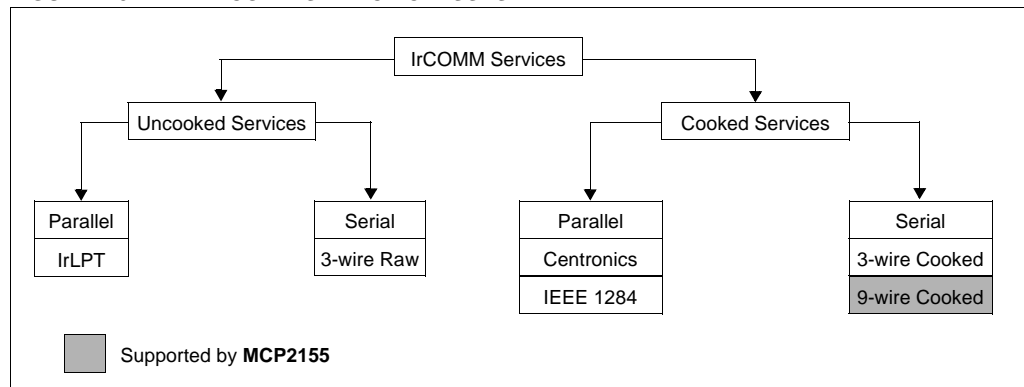

MCP2155

2.9.2 OTHER OPTIONAL IrDA DATA PROTOCOLS

Other IrDA data protocols have been developed to specific application requirements. These optional protocols are not supported in the MCP2155. These IrDA data protocols are briefly described in the following sub-sections. For additional information, please refer to the IrDA website (www.IrDA.org).

2.9.2.1 IrTran-P

IrTran-P provides the protocol to exchange images with digital image capture devices/cameras.

2.9.2.2 IrOBEX

IrOBEX provides OBject EXchange services. This is similar to HTTP.

2.9.2.3 IrLAN

IrLAN describes a protocol to support IR wireless access to a Local Area Network (LAN).

2.9.2.4 IrMC

IrMC describes how mobile telephony and communication devices can exchange information. This information includes phonebook, calendar, and message data.

Also how call control and real-time voice are handled (RTCON).

2.9.2.5 IrDA Lite

IrDA Lite describes how to reduce the application code requirements, while maintaining compatibility with the full implementation.

MCP2155

2.9.3 HOW DEVICES CONNECT

When two devices implementing the IrDA standard feature establish a connection using the IrCOMM protocol, the process is analogous to connecting two devices with serial ports using a cable. This is referred to as a "point-to-point" connection. This connection is limited to half-duplex operation because the IR transceiver cannot transmit and receive at the same time. The purpose of the IrDA protocol is to allow this half-duplex link to emulate, as much as possible, a full-duplex connection. In general, this is done by dividing the data into "packets", or groups of data. These packets can then be sent back and forth when needed without risk of collision. The rules of how and when these packets are sent constitute the IrDA protocols. The MCP2155 supports elements of this IrDA protocol to communicate with other IrDA standard compatible devices.

When a wired connection is used, the assumption is made that both sides have the same communications parameters and features. A wired connection has no need to identify the other connector, because it is assumed that the connectors are properly connected. In the IrDA standard, a connection process has been defined to identify other IrDA compatible devices and establish a communication link. There are three steps that these two devices go through to make this connection. These are:

- Normal Disconnect Mode (NDM)
- Discovery Mode
- Normal Connect Mode (NCM)

Figure 2-10 shows the connection sequence.

2.9.3.1 Normal Disconnect Mode (NDM)

When two IrDA standard compatible devices come into range they must first recognize each other. The basis of this process is that one device has some task to accomplish and the other device has a resource needed to accomplish this task. One device is referred to as a Primary device and the other is referred to as a Secondary device. This distinction between Primary device and Secondary device is important. It is the responsibility of the Primary device to provide the mechanism to recognize other devices. So the Primary device must first poll for nearby IrDA standard compatible devices. During this polling, the default baud rate of 9600 baud is used by both devices.

For example, if you want to print from an IrDA equipped laptop to an IrDA printer utilizing the IrDA standard feature, you would first bring your laptop in range of the printer. In this case, the laptop is the one that has something to do and the printer has the resource to do it. The laptop is called the Primary device and the printer is the Secondary device. Some data-capable cellphones have IrDA standard infrared ports. If you used such a cellphone with a Personal Dig-

ital Assistants (PDAs), the PDA that supports the IrDA standard feature would be the Primary device and the cellphone would be the Secondary device.

When a Primary device polls for another device, then a nearby Secondary device may respond. When a Secondary device responds, the two devices are defined to be in the Normal Disconnect Mode (NDM) state. NDM is established by the Primary device broadcasting a packet and waiting for a response. These broadcast packets are numbered. Usually 6 or 8 packets are sent. The first packet is number 0, the last packet is usually number 5 or 7. After all the packets are sent, the Primary device then sends an ID packet which is not numbered.

The Secondary device waits for these packets, and then responds to one of the packets. The packet it responds to determines the "time slot" to be used by the Secondary device. For example, if the Secondary device responds after packet number 2, then the Secondary device will use time slot 2. If the Secondary device responds after packet number 0, then the Secondary device will use time slot 0. This mechanism allows the Primary device to recognize as many nearby devices as there are time slots. The Primary device will continue to generate time slots and the Secondary device should continue to respond, even if there's nothing to do.

Note 1: The MCP2155 can only be used to implement a Secondary device.

2: The MCP2155 supports a system with only one Secondary device having exclusive use of the IrDA standard infrared link (known as "point-to-point" communication).

3: The MCP2155 always takes time slot 2.

4: If another Secondary device is nearby, the Primary device may fail to recognize the MCP2155, or the Primary device may not recognize either of the devices.

During NDM, the MCP2155 handles all of the responses to the Primary device (see Figure 2-10), without any communication with the Host controller. The Host controller is inhibited by the CTS signal, of the MCP2155, from sending data to the MCP2155.

MCP2155

2.9.3.2 Discovery Mode

Discovery mode allows the Primary device to determine the capabilities of the Secondary device. The discovery mode is entered after the MCP2155 (Secondary device) has sent an XID response to the Primary device, and the Primary device has completed sending the XIDs and then sends a Broadcast ID. If this sequence is not completed, then a Primary device and a Secondary device can stay in NDM indefinitely.

When the Primary device has something to do, it then initiates Discovery. Discovery has two parts. these are:

- Link initialization
- Resource determination

The first step is for the Primary device and Secondary device to determine and then adjust to each other's hardware capabilities. These capabilities are parameters like:

- Data rate
- Turn around time
- Number of packets without a response
- How long to wait before disconnecting

Both the Primary device and Secondary device begin communications at 9600 baud, which is the default baud rate. The Primary device sends its parameters, then the Secondary device responds with its parameters. For example, if the Primary supports all data rates up to 115.2 kbaud and the Secondary device only supports 19.2 kbaud then the link will be established at 19.2 kbaud.

Note: The MCP2155 is limited to a data rate of 115.2 kbaud.

After the hardware parameters are established, the Primary device must determine if the Secondary device has the resources it requires. If the Primary device has a job to print, then it has to know if it's talking to a printer, not a modem or other device. This determination is made using the Information Access Service, (IAS). The job of the Secondary device is to respond to IAS queries made by the Primary device. The Primary device must ask a series of questions like:

- What is the name of your service?
- What is the address of this service?
- What are the capabilities of this device?

When all the Primary device's questions are answered, the Primary device can access the service provided by the Secondary device.

During Discovery Mode, the MCP2155 handles all of the responses to the Primary device (see [Figure 2-10](#)), without any communication with the Host controller. The Host controller is inhibited by the CTS signal, of the MCP2155, from sending data to the MCP2155.

2.9.3.3 Normal Connect Mode (NCM)

After discovery has been completed, the Primary device and MCP2155 (Secondary device) can freely exchange data.

The MCP2155 can receive IR data or serial data, but not both at the same time. The MCP2155 uses a hardware handshake to stop the local serial port from sending data while the MCP2155 is receiving IR data.

Note: Data loss will result if this hardware handshake is not observed.

Both the Primary device and MCP2155 (Secondary device) check to make sure that data packets are received by the other without errors. Even when data is required to be sent the Primary device and Secondary device will still exchange packets just to make sure that the connection hasn't unexpectedly been dropped. When the Primary device has finished, it then transmits the close link command to the MCP2155 (Secondary device). The MCP2155 will confirm the close link command, and then both the Primary device and MCP2155 (Secondary device) will revert to the NDM state.

Note: If the NCM mode is unexpectedly terminated for any reason (including the Primary device not issuing a close link command), the MCP2155 will revert to the NDM state 10 seconds after the last frame has been received.

It is the responsibility of the Host controller program to understand the meaning of the data received, and how the program should respond to it. This is the same as if the data was being received by the host controller from a UART.

MCP2155

FIGURE 2-10: CONNECTION SEQUENCE

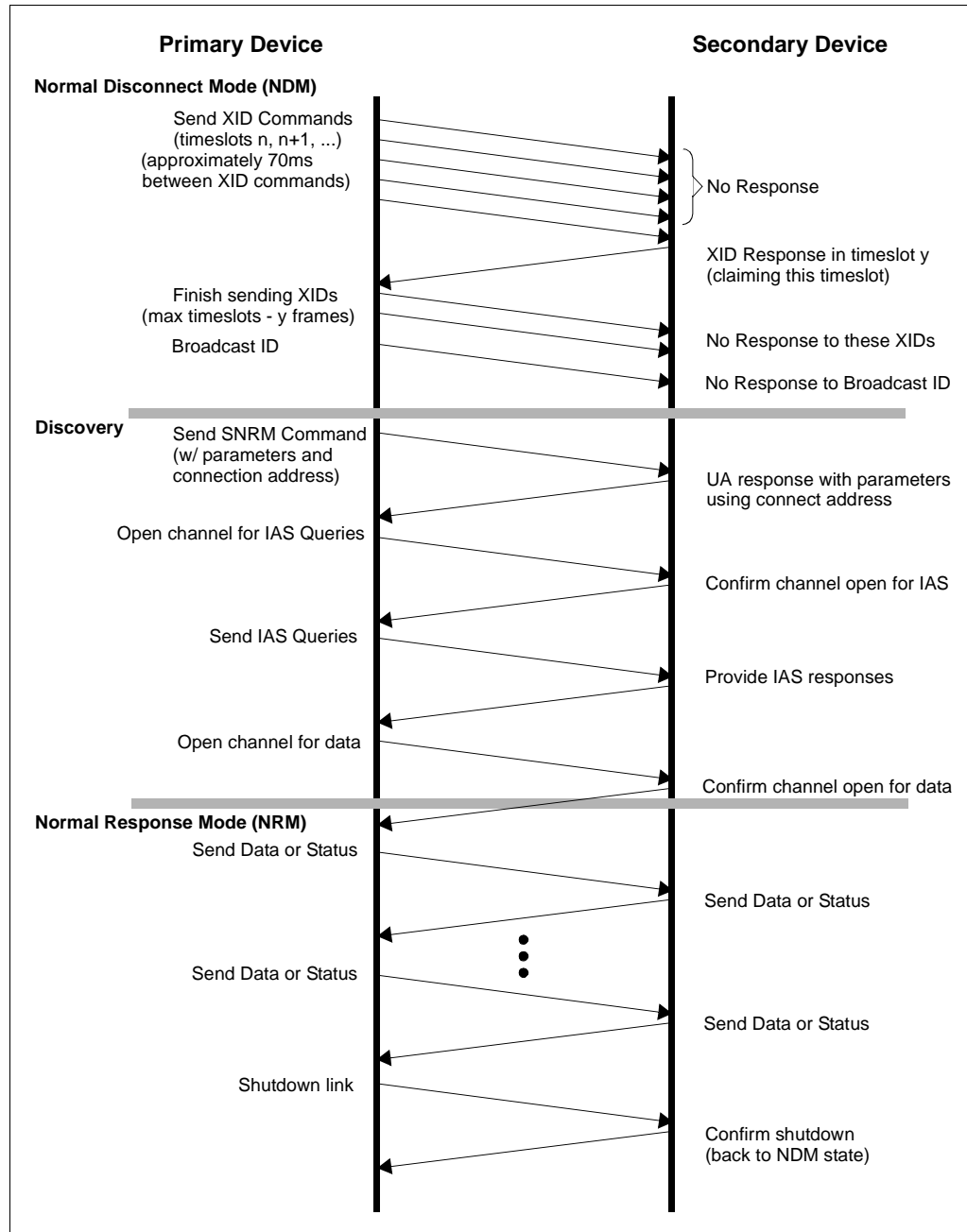

MCP2155

2.10 Operation

The MCP2155 emulates a modem connection. The application on the DCE device sees a virtual serial port. This serial port emulation is provided by the IrDA standard protocols. The link between the DCE device and the embedded application is made using the MCP2155. The connection between the MCP2155 and the embedded application should be wired as a modem connection.

The Data Set Ready (DSR) signal of the MCP2155 is used to indicate if a valid IrDA standard infrared link has been established between the MCP2155 and the Primary device (DCE host). The DSR signal should be monitored closely to make sure that any communication tasks can be completed.

To indicate that the MCP2155 has powered-up, successfully initialized, and is ready for service, monitor the CTS signal for a High level. The CTS signal is driven High during the NDM and Discovery states, and may be either High or Low during the NCM state.

The MCP2155 generates the CTS signal locally.

Note: The RTS and CTS signals are local emulations.

2.10.1 HARDWARE HANDSHAKING

The MCP2155 uses a 64-byte buffer for incoming data from the IR Host. Another 64-byte buffer is provided to buffer data from the UART serial port. When an IR packet begins the IrComm, the MCP2155 handles IR data exclusively. So the UART serial port buffer is not available. A hardware handshaking pin (CTS) is provided to inhibit the host controller from sending serial data while IR Data is being sent or received.

Note: When the CTS output from the IrComm is high, no data should be sent from the Host controller. The UART FIFO will store up to 2 bytes. Any additional data bytes will be lost.

2.10.2 BUFFERS AND THROUGHPUT

The maximum IR data rate of the MCP2155 is 115.2 kbaud. The actual throughput will be less due to several factors, the most significant of which are under the control of the developer. One factor beyond the control of the designer is the overhead associated with the IrDA standard. The MCP2155 uses a fixed data block size of 64-bytes. To carry 64 bytes of data the MCP2155 must send 72 bytes (64+8). The additional 8 bytes are used by the protocol. When the Primary device receives the frame it must wait for a minimum latency period before sending a packet of its own. This turnaround time is set by IrLAP when the parameters of the link are negotiated. A common turnaround time is 1ms, although longer and shorter times may be encountered. 1 ms represents approximately 12 byte times at a data rate of 115.2 kbaud. The minimum size frame that the Primary device can respond with is 6 bytes. The MCP2155 will add the 12 byte-time latency of its own, again assuming a 1ms latency. This means that the maximum throughput will be 64 data bytes out of a total of 64 + 38 byte times. Thus, the maximum theoretical throughput will be limited to about 64/(64+38)=63% of the IR data rate. Actual maximum throughput will be between 38.4 kbaud and 57.6 kbaud. This difference is due to processing time of the receiving station and other factors.

The most significant factor in data throughput is how well the data frames are filled. If only 1 byte is sent at a time, then the maximum throughput is 1/(1+38)=2.5% of the IR data rate. The best way to maximize throughput is to align the amounts of data with the packet size of the MCP2155. Throughput examples are shown in [Table 2-4](#).

TABLE 2-4: IrDA STANDARD THROUGHPUT EXAMPLES @ 115.2 KBAUD

MCP2155 Data Packet Size (Bytes)	Overhead (Bytes)	Primary Device Minimum Response (Bytes)	Primary Device Turn-around Time ⁽¹⁾ (Bytes)	MCP2155 Turn-around Time ⁽¹⁾ (Bytes)	Total Bytes Transmitted	Throughput % (Data/Total)
64	8	6	12	12	102	62.7%
1	8	6	12	12	39	2.6%

Note 1: Number of bytes calculated based on a common turnaround time of 1 ms.

MCP2155

2.11 Turnaround Latency

An IR link can be compared to a one-wire data connection. The IR transceiver can transmit or receive, but not both at the same time. A delay of one bit time is suggested between the time a byte is received and another byte is transmitted.

2.12 IR Port Baud Rate

The baud rate for the MCP2155 IR port (the TXIR and RXIR pins) is initially at the default rate of 9600 baud. The Host controller will determine the maximum baud rate that the MCP2155 can support. This information is used during NDM with the Primary device to set the baud rate of the IR link. The maximum IR baud rate is not required to be the same as the MCP2155's serial port (UART) baud rate (as determined by the BAUD1:BAUD0 pins).

2.13 Programmable Device ID

The MCP2155 has a flexible feature that allows the MCP2155 Device ID to be changed by the Host controller. The default ID is "Generic IrDA", and is stored in non-volatile electrically erasable programmable memory (EEPROM). The maximum ID String length is 19 bytes. The format of the ID EEPROM is shown in [Figure 2-11](#).

The ID String must only contain the ASCII characters from 20h to 7Ah (inclusive).

The MCP2155 enters into ID String programming when the MCP2155 exits the reset state and detects that the DTR pin is High and the RTS pin is Low.

A Host controller connected to the MCP2155 would typically do the following steps to place the MCP2155 into ID String programming mode:

1. Force the MCP2155 into reset (RESET pin forced Low).
2. Force the DTR pin High and the RTS pin Low.
3. Release the MCP2155 from reset (RESET pin forced High).

Once the MCP2155 is ready to receive data, the CTS pin will be forced low. Data may now be transferred, following the format in [Figure 2-11](#). The CTS pin determines the flow control, and the Host controller must monitor this signal to ensure that the data byte may be sent.

Once the Host controller has sent its last byte, the DTR pin must be set Low. This ensures that if another reset occurs, the MCP2155 will not re-enter ID String programming mode. The MCP2155 uses the String Length (1st byte transmitted) to determine when to ID String programming mode has completed. This returns the MCP2155 to normal operation.

Note 1: If a non-valid ID String (contains an ASCII character not in the valid range) is programmed, the MCP2155 will not create a link with a primary device.

2: The communication program that is supplied with Microsoft Windows operating system (called Hyper Terminal), may leave the DTR signal High and the RTS signals Low when the program disconnects, or is closed. Care should be taken to ensure that this could not accidentally cause the MCP2155 to enter Device ID String Programming.

[Example 2-1](#) show the firmware code for a PIC16Cxxx acting as the Host controller to modify the MCP2155 Device ID String.

FIGURE 2-11: ID STRING FORMAT

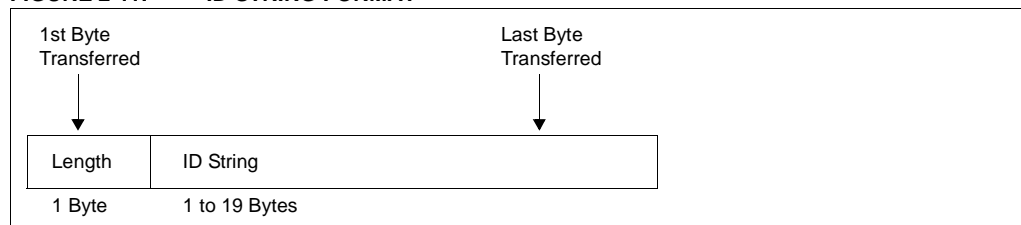

MCP2155

EXAMPLE 2-1: PIC16Fxx Code to Program the Device ID

```

;#define   dtr   PORTx, Pinx   ; Must specify which Port and Which Pin
;#define   cts   PORTx, Pinx   ; Must specify which Port and Which Pin
;#define   rts   PORTx, Pinx   ; Must specify which Port and Which Pin
;#define   clr   PORTx, Pinx   ; Must specify which Port and Which Pin
;
;*****
; String Table
; This table stores a string, breg is the offset.  The string
; is terminated by a null character.
;*****
string1 clrf   PCLATH           ; this routine is on page 0
        movf   breg, W         ; get the offset
        addwf  PCL, F         ; add the offset to PC
        DT    D'15'           ; the first byte is the byte count
        DT    "My IR ID String"
;
UpdateID
        call   deviceInit     ; Initialize the PIC16Fxxx
        bcf   clr             ; place the MCP2155 in reset
        bsf   dtr             ; Force the DTR pin High for program mode
        bcf   rts             ; Force the RTS pin Low for program mode
        call  delay1mS        ; delay for 1 ms.
        bsf   clr             ; allow the MCP2155 to come out of reset
;
        clrf  LoopCnt         ; LoopCnt = 0
ctsLP1  call  delay1mS        ; delay for 1 ms.
        btfss cts             ; if cts=0 then we're ready to program
        goto  ctsLow          ; MCP2155 is ready to receive data
        decfsz LoopCnt, F     ;
        goto  ctsLP1         ; NO, wait for MCP2155 to be ready
        goto  StuckReset      ; The MCP2155 did not exit reset, do your recovery
; in this routine.

```

MCP2155

EXAMPLE 2-1: PIC16Fxx Code to Program the Device ID (continued)

```

ctsLow  clrf    breg          ; clear the offset
        call   string1       ; get the byte count
                                ; (ID length byte + # bytes in string)
        movwf  creg          ; use creg as the loop counter
        incf   creg, f       ; add 1 to the loop count since
                                ; we're jumping into the middle
        movwf  areg          ; save the count in areg to send it
        goto   sndwt        ; start sending the count + ID string
;
sndlp   call   string1       ; get the byte
        movwf  areg          ; save the byte
sndwt   btfsc  cts           ; check the cts input
        goto   sndwt        ; wait if cts=1
        call   txser        ; send the byte using the Transmit Routine
        incf   breg, f       ; increment the table pointer
        decfsz creg, f       ; more bytes to send?
        goto   sndlp        ; YES, send more bytes
;
        bcf   clr           ; NO, place the MCP2155 in reset
        bcf   dtr           ; Force the DTR pin Low for normal mode
        bsf   rts           ; Force the RTS pin High for normal mode
        call  delay1mS      ; delay for 1 ms.
        bsf   clr           ; allow the MCP2155 to come out of reset
;
ctsLP2  btfss  cts           ; if cts=1 then MCP2155 is in Normal mode
        goto   ctsLP2       ; NO, wait for MCP2155 to be ready
        goto   NormalOperation ; The MCP2155 is now programmed with new ID,
                                ; and is ready to establish an IR link

```

MCP2155

2.14 Optical Transceiver

The MCP2155 requires an infrared transceiver. The transceiver can be a integrated solution. Table 2-5 shows a list of common manufacturers of integrated optical transceivers. A typical optical transceiver circuit using a Vishay/Temic TFDS4500 is shown in Figure 2-12.

FIGURE 2-12: TYPICAL OPTICAL TRANSCEIVER CIRCUIT

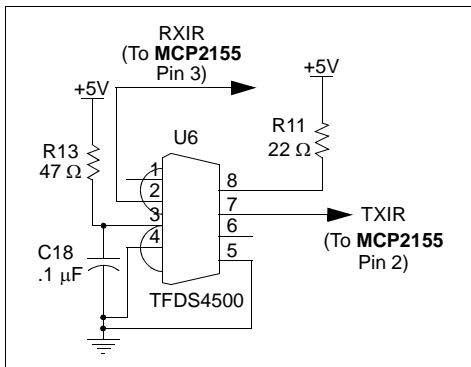

The optical transceiver logic can be implemented with discrete components, for component cost savings. Care must be taken in the design and layout of the photo detect circuit. This is due to the small signals that are being detected and their sensitivity to noise. A discrete implementation of the optical transceiver logic is implemented on the MCP2120 and MCP2150 Developer's Kit boards.

Note: The discrete optical transceiver implementation on the MCP2120 and MCP2150 Developer's Kit boards may not meet the IrDA specifications for the physical layer (IrPHY). Any discrete solution will require appropriate validation for the user's application.

2.15 References

The IrDA Standards download page can be found at:

<http://www.irda.org/standards/specifications>

Some common manufacturers of Optical Transceivers are shown in Table 2-5.

TABLE 2-5: COMMON OPTICAL TRANSCEIVER MANUFACTURERS

Company	Company Web Site Address
Infineon	www.infineon.com
Agilent	www.agilent.com
Vishay/Temic	www.vishay.com
Rohm	www.rohm.com

MCP2155

3.0 DEVELOPMENT TOOLS

The MCP2155 is supported by the MCP2120/MCP2150 Developer's Kit (order number DM163008). This kit allows the user to demonstrate the operation of the MCP2155 by doing some hardware "cuts" on the MCP2150 Developer's board.

Each kit (DM163008) comes with two MCP2120 Developer's boards and one MCP2150 Developer's Board to demonstrate transmission/reception of infrared data streams. Figure 3-1 shows a block diagram of the MCP2150 Developer's Board and the 4 lines that are to be "cut". The use of MCP2155 requires that the Header interface is used (SP3238E disconnected from system).

As can be seen, the user has jumper options for both the interface to the host controller (UART or Header) and the transceiver solution (Integrated or discrete component).

The UART interface allows a direct connection to a PC (use a terminal emulation program), or a header to allow easy connection to host prototypes (or one of the Microchip PICDEM™ boards).

The transceiver logic is jumpered to allow the selection of either a single chip transceiver solution, or a low cost discrete solution. This low cost discrete solution allows a lower system cost to be achieved. With the lower cost comes some trade-offs of the IrDA standard physical layer specifications. These trade-offs need to be evaluated to ensure the characteristics of the component solution meet the requirements of the system.

This kit comes with two identical MCP2120 Developer's Boards and a single MCP2150 Developer's board. This allows a complete system (Transmitter and Receiver) to be implemented with either system requirement (simple encoder/decoder or IrDA standard protocol stack plus encoder/decoder).

FIGURE 3-1: MCP2150 DEVELOPER'S KIT BLOCK DIAGRAM

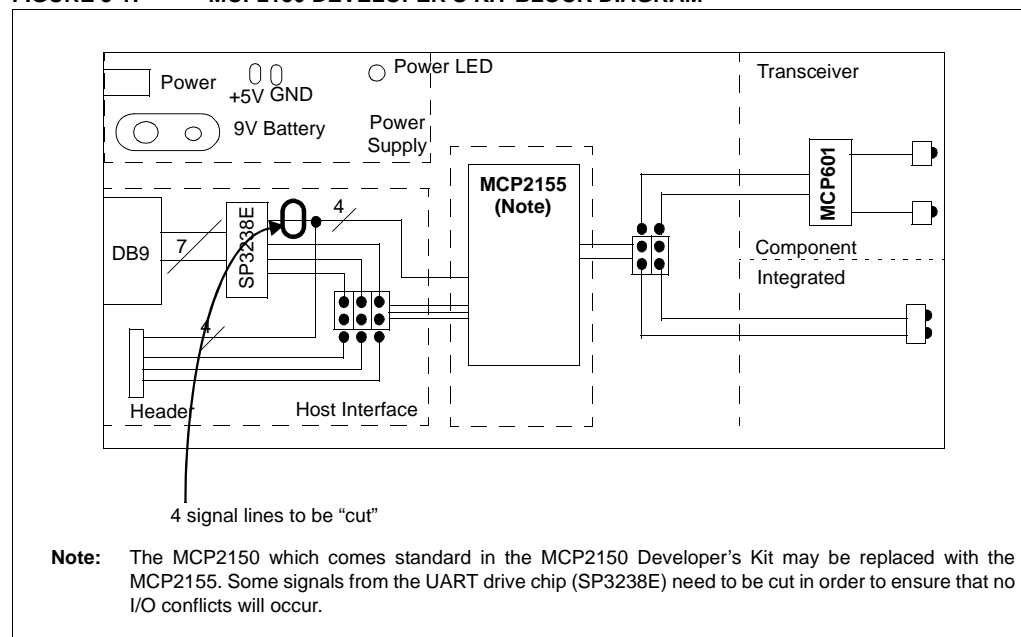



MCP2155



NOTES:

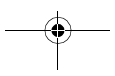
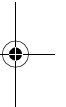
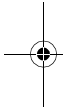

MCP2155

4.0 ELECTRICAL CHARACTERISTICS

Absolute Maximum Ratings†

Ambient Temperature under bias	-40°C to +125°C
Storage Temperature	-65°C to +150°C
Voltage on V _{DD} with respect to V _{SS}	-0.3V to +6.5V
Voltage on $\overline{\text{RESET}}$ with respect to V _{SS}	-0.3V to +14V
Voltage on all other pins with respect to V _{SS}	-0.3V to (V _{DD} + 0.3V)
Total Power Dissipation ⁽¹⁾	800 mW
Max. Current out of V _{SS} pin	300 mA
Max. Current into V _{DD} pin	250 mA
Input Clamp Current, I _{IK} (V _I < 0 or V _I > V _{DD})	±20 mA
Output Clamp Current, I _{OK} (V _O < 0 or V _O > V _{DD}).....	±20 mA
Max. Output Current sunk by any Output pin.....	25 mA
Max. Output Current sourced by any Output pin.....	25 mA

Note 1: Power Dissipation is calculated as follows:

$$P_{DIS} = V_{DD} \times (I_{DD} - \sum I_{OH}) + \sum \{(V_{DD} - V_{OH}) \times I_{OH}\} + \sum (V_{OL} \times I_{OL})$$

†NOTICE: Stresses above those listed under "Maximum Ratings" may cause permanent damage to the device. This is a stress rating only and functional operation of the device at those or any other conditions above those indicated in the operation listings of this specification is not implied. Exposure to maximum rating conditions for extended periods may affect device reliability.

MCP2155

FIGURE 4-1: VOLTAGE-FREQUENCY GRAPH, $-40^{\circ}\text{C} \leq T_A \leq +85^{\circ}\text{C}$

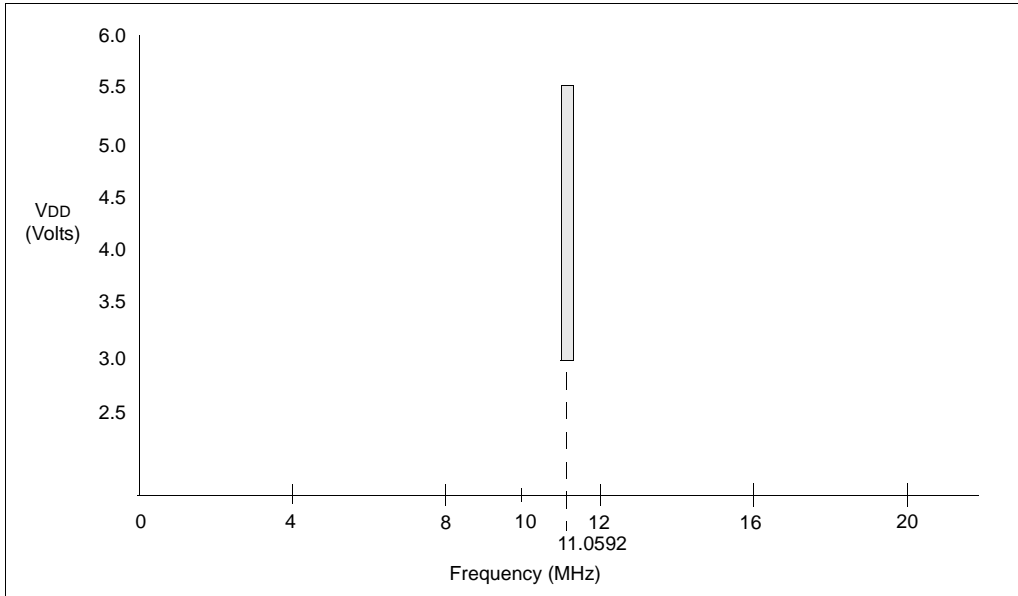

MCP2155

4.1 DC Characteristics

DC Characteristics			Standard Operating Conditions (unless otherwise specified) Operating Temperature: $-40^{\circ}\text{C} \leq T_A \leq +85^{\circ}\text{C}$ (industrial)				
Param. No.	Sym	Characteristic	Min	Typ ⁽¹⁾	Max	Units	Conditions
D001	VDD	Supply Voltage	3.0	—	5.5	V	See Figure 4-1
D002	VDR	RAM Data Retention Voltage ⁽²⁾	2.0	—	—	V	Device Oscillator/Clock stopped
D003	VPOR	VDD Start Voltage to ensure Power-on Reset	—	VSS	—	V	
D004	SVDD	VDD Rise Rate to ensure Power-on Reset	0.05	—	—	V/ms	
D010	IDD	Supply Current ⁽³⁾	—	—	2.2	mA	FOSC = 11.0592 MHz, VDD = 3.0V
			—	4.0	7.0	mA	FOSC = 11.0592 MHz, VDD = 5.5V
D020	IPD	Device Disabled Current ^(3, 4)	—	—	2.2	μA	VDD = 3.0V
			—	—	9	μA	VDD = 5.5V

Note 1: Data in the Typical ("Typ") column is based on characterization results at 25°C. This data is for design guidance only and is not tested.

2: This is the limit to which VDD can be lowered without losing RAM data.

3: The supply current is mainly a function of the operating voltage and frequency. Pin loading, pin rate, and temperature have an impact on the current consumption.

a) The test conditions for all IDD measurements are made when device is enabled (EN pin is high):
OSC1 = external square wave, from rail-to-rail; all input pins pulled to VSS, RXIR = VDD,
RESET = VDD;

b) When device is disabled (EN pin is low), the conditions for current measurements are the same.

4: When the device is disabled (EN pin is low), current is measured with all input pins tied to VDD or VSS and the output pins driving a high or low level into infinite impedance.

MCP2155

DC Characteristics (Continued)

DC CHARACTERISTICS			Standard Operating Conditions (unless otherwise specified)				
			Operating temperature: $-40^{\circ}\text{C} \leq T_A \leq +85^{\circ}\text{C}$ (industrial)				
			Operating voltage VDD range as described in DC spec Section 4.1 .				
Param No.	Sym	Characteristic	Min	Typ	Max	Units	Conditions
Input Low Voltage							
D030	V _{IL}	Input pins with TTL buffer (TX, RI, DTR, RTS, CD, and EN)	V _{SS}	—	0.8V	V	$4.5 \leq V_{DD} \leq 5.5V$
D030A			V _{SS}	—	0.15V _{DD}	V	otherwise
D031		with Schmitt Trigger buffer (BAUD1, BAUD0, and RXIR)	V _{SS}	—	0.2V _{DD}	V	
D032		$\overline{\text{RESET}}$	V _{SS}	—	0.2V _{DD}	V	
D033		OSC1	V _{SS}	—	0.3V _{DD}	V	
Input High Voltage							
D040	V _{IH}	Input pins with TTL buffer (TX, RI, DTR, RTS, CD, and EN)	2.0	—	V _{DD}	V	$4.5 \leq V_{DD} \leq 5.5V$
D040A			0.25V _{DD} + 0.8	—	V _{DD}	V	otherwise
D041		with Schmitt Trigger buffer (BAUD1, BAUD0, and RXIR)	0.8V _{DD}	—	V _{DD}	V	
D042		$\overline{\text{RESET}}$	0.8V _{DD}	—	V _{DD}	V	
D043		OSC1	0.7V _{DD}	—	V _{DD}	V	
Input Leakage Current (Notes 1, 2)							
D060	I _{IL}	Input pins	—	—	±1	μA	$V_{SS} \leq V_{PIN} \leq V_{DD}$, Pin at hi-impedance
D061		$\overline{\text{RESET}}$	—	—	±5	μA	$V_{SS} \leq V_{PIN} \leq V_{DD}$
D063		OSC1	—	—	±5	μA	$V_{SS} \leq V_{PIN} \leq V_{DD}$

Note 1: The leakage current on the $\overline{\text{RESET}}$ pin is strongly dependent on the applied voltage level. The specified levels represent normal operating conditions. Higher leakage current may be measured at different input voltages.

Note 2: Negative current is defined as coming out of the pin.

MCP2155

DC Characteristics (Continued)

DC CHARACTERISTICS			Standard Operating Conditions (unless otherwise specified)				
			Operating temperature: $-40^{\circ}\text{C} \leq T_A \leq +85^{\circ}\text{C}$ (industrial)				
			Operating voltage V_{DD} range as described in DC spec Section 4.1				
Param No.	Sym	Characteristic	Min	Typ	Max	Units	Conditions
Output Low Voltage							
D080	VOL	TXIR, RX, DSR, and CTS pins	—	—	0.6	V	$I_{OL} = 8.5 \text{ mA}$, $V_{DD} = 4.5\text{V}$
D083		OSC2	—	—	0.6	V	$I_{OL} = 1.6 \text{ mA}$, $V_{DD} = 4.5\text{V}$
Output High Voltage							
D090	VOH	TXIR, RX, DSR, and CTS pins (Note 1)	$V_{DD} - 0.7$	—	—	V	$I_{OH} = -3.0 \text{ mA}$, $V_{DD} = 4.5\text{V}$
D092		OSC2	$V_{DD} - 0.7$	—	—	V	$I_{OH} = -1.3 \text{ mA}$, $V_{DD} = 4.5\text{V}$
Capacitive Loading Specs on Output Pins							
D100	Cosc2	OSC2 pin	—	—	15	pF	when external clock is used to drive OSC1.
D101	Cio	All Input or Output pins	—	—	50	pF	

Note 1: Negative current is defined as coming out of the pin.

MCP2155

4.2 Timing Parameter Symbolology and Load Conditions

The timing parameter symbols have been created following one of the following formats:

4.2.1 TIMING CONDITIONS

The temperature and voltages specified in [Table 4-2](#) apply to all timing specifications unless otherwise noted. [Figure 4-2](#) specifies the load conditions for the timing specifications.

TABLE 4-1: SYMBOLOGY

1. TppS2ppS		2. TppS	
T			
F	Frequency	T	Time
E	Error		
Lowercase letters (pp) and their meanings:			
pp			
io	Input or Output pin	osc	Oscillator
rx	Receive	tx	Transmit
bitclk	RX/TX BITCLK	RST	Reset
drt	Device Reset Timer		
Uppercase letters and their meanings:			
S			
F	Fall	P	Period
H	High	R	Rise
I	Invalid (Hi-impedance)	V	Valid
L	Low	Z	Hi-impedance

TABLE 4-2: AC TEMPERATURE AND VOLTAGE SPECIFICATIONS

AC CHARACTERISTICS	Standard Operating Conditions (unless otherwise stated) Operating temperature $-40^{\circ}\text{C} \leq T_A \leq +85^{\circ}\text{C}$ (industrial) Operating voltage VDD range as described in DC spec Section 4.1 .
---------------------------	--

FIGURE 4-2: LOAD CONDITIONS FOR DEVICE TIMING SPECIFICATIONS

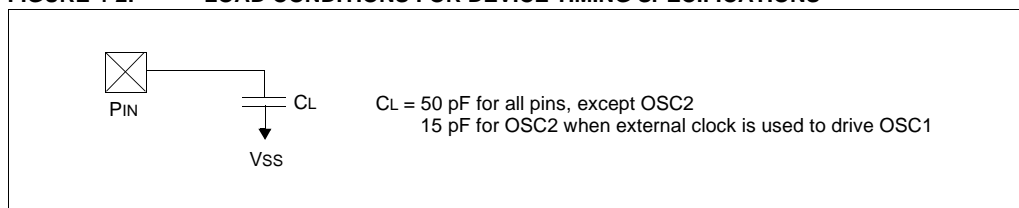

MCP2155

4.3 Timing Diagrams and Specifications

FIGURE 4-3: EXTERNAL CLOCK TIMING

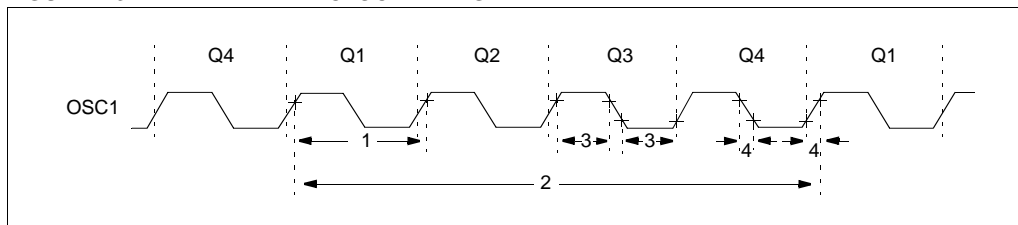
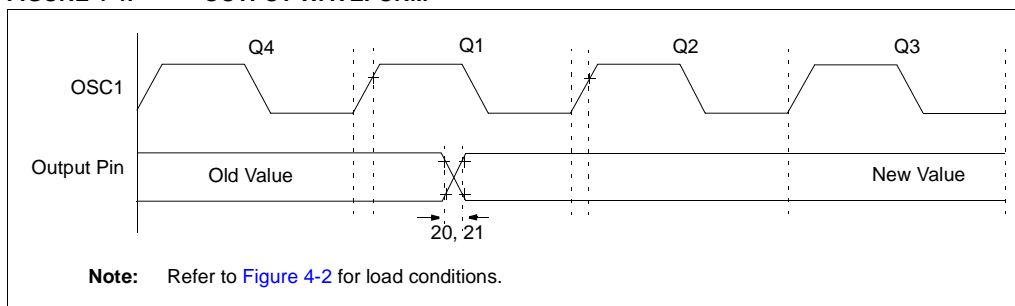

TABLE 4-3: EXTERNAL CLOCK TIMING REQUIREMENTS

AC Characteristics			Standard Operating Conditions (unless otherwise specified)				
			Operating Temperature: $-40^{\circ}\text{C} \leq T_A \leq +85^{\circ}\text{C}$ (industrial)				
			Operating Voltage V_{DD} range is described in Section 4.1				
Param. No.	Sym	Characteristic	Min	Typ ⁽¹⁾	Max	Units	Conditions
1	TOSC	External CLKIN Period ^(2, 3)	90.422	—	90.422	ns	Device Operation Disable Clock for low power
		Oscillator Period ⁽²⁾	90.422	—	90.422	ns	
1A	FOSC	External CLKIN Frequency ^(2, 3)	11.0592	—	11.0592	MHz	
		Oscillator Frequency ⁽²⁾	11.0592	—	11.0592	MHz	
1B	FERR	Error in Frequency	—	—	± 0.01	%	
1C	ECLK	External Clock Error	—	—	± 0.01	%	
4	TosR, TosF	Clock in (OSC1) Rise or Fall Time	—	—	15	ns	

- Note 1:** Data in the Typical ("Typ") column is at 5V, 25°C unless otherwise stated. These parameters are for design guidance only and are not tested.
- 2:** All specified values are based on oscillator characterization data under standard operating conditions. Exceeding these specified limits may result in unstable oscillator operation and/or higher than expected current consumption. When an external clock input is used, the "max" cycle time limit is "DC" (no clock) for all devices.
- 3:** A duty cycle of no more than 60% (High time/Low time, or Low time/High time) is recommended for external clock inputs.

MCP2155

FIGURE 4-4: OUTPUT WAVEFORM

TABLE 4-4: OUTPUT TIMING REQUIREMENTS

AC Characteristics			Standard Operating Conditions (unless otherwise specified)				
			Operating Temperature: $-40^{\circ}\text{C} \leq T_A \leq +85^{\circ}\text{C}$ (industrial)				
			Operating Voltage V_{DD} range is described in Section 4.1				
Param. No.	Sym	Characteristic	Min	Typ ⁽¹⁾	Max	Units	Conditions
20	ToR	RX and TXIR pin rise time ⁽²⁾	—	10	25	ns	
21	ToF	RX and TXIR pin fall time ⁽²⁾	—	10	25	ns	

Note 1: Data in the Typical ("Typ") column is at 5V, 25°C unless otherwise stated.

Note 2: See [Figure 4-2](#) for loading conditions.

MCP2155

FIGURE 4-5: RESET AND DEVICE RESET TIMING

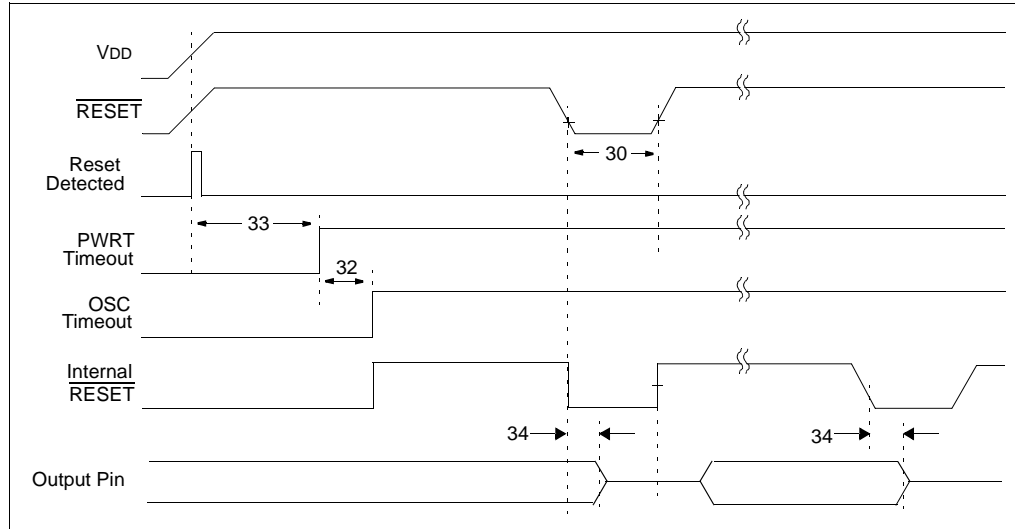
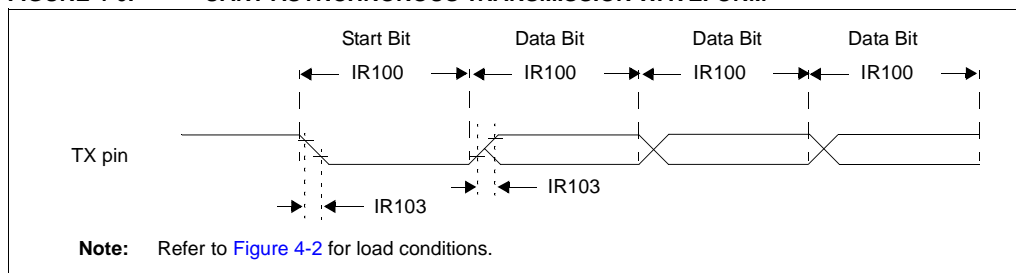

TABLE 4-5: RESET AND DEVICE RESET REQUIREMENTS

AC Characteristics			Standard Operating Conditions (unless otherwise specified)				
			Operating Temperature: $-40^{\circ}\text{C} \leq T_A \leq +85^{\circ}\text{C}$ (industrial)				
			Operating Voltage VDD range is described in Section 4.1				
Param. No.	Sym	Characteristic	Min	Typ ⁽¹⁾	Max	Units	Conditions
30	TRSTL	RESET Pulse Width (low)	2000	—	—	ns	VDD = 5.0 V
32	TOST	Oscillator Start-up Timer Period	1024	—	1024	TOSC	
33	TPWRT	Power up Timer Period	28	72	132	ms	VDD = 5.0 V
34	TIOZ	Output Hi-impedance from RESET Low or device Reset	—	—	2	μs	

Note 1: Data in the Typical ("Typ") column is at 5V, 25°C, unless otherwise stated.

MCP2155

FIGURE 4-6: UART ASYNCHRONOUS TRANSMISSION WAVEFORM

TABLE 4-6: UART ASYNCHRONOUS TRANSMISSION REQUIREMENTS

AC Characteristics			Standard Operating Conditions (unless otherwise specified) Operating Temperature: $-40^{\circ}\text{C} \leq T_A \leq +85^{\circ}\text{C}$ (industrial) Operating Voltage V_{DD} range is described in Section 4.1				
Param. No.	Sym	Characteristic	Min	Typ	Max	Units	Conditions
IR100	TTXBIT	Transmit Baud rate	1152	—	1152	Tosc	BAUD2:BAUD0 = 00
			576	—	576	Tosc	BAUD2:BAUD0 = 01
			192	—	192	Tosc	BAUD2:BAUD0 = 10
			96	—	96	Tosc	BAUD2:BAUD0 = 11
IR101	ETXBIT	Transmit (TX pin) Baud rate Error (into MCP2155)	—	—	± 2	%	
IR102	ETXIRBIT	Transmit (TXIR pin) Baud rate Error (out of MCP2155) ⁽¹⁾	—	—	± 1	%	
IR103	TTXRF	TX pin rise time and fall time	—	—	25	ns	

Note 1: This error is not additive to IR101 parameter.

MCP2155

FIGURE 4-7: UART ASYNCHRONOUS RECEIVE TIMING

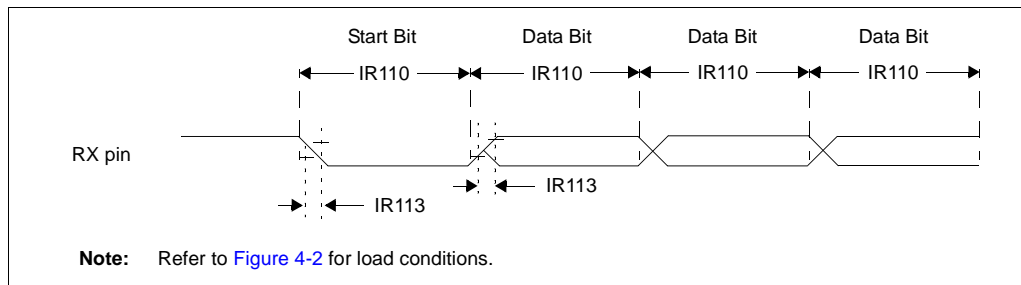

TABLE 4-7: UART ASYNCHRONOUS RECEIVE REQUIREMENTS

AC Characteristics			Standard Operating Conditions (unless otherwise specified)				
			Operating Temperature: $-40^{\circ}\text{C} \leq T_A \leq +85^{\circ}\text{C}$ (industrial)				
			Operating Voltage VDD range is described in Section 4.1				
Param. No.	Sym	Characteristic	Min	Typ	Max	Units	Conditions
IR110	TRXBIT	Receive Baud Rate	1152	—	1152	Tosc	BAUD2:BAUD0 = 00
			576	—	576	Tosc	BAUD2:BAUD0 = 01
			192	—	192	Tosc	BAUD2:BAUD0 = 10
			96	—	96	Tosc	BAUD2:BAUD0 = 11
IR111	ERXBIT	Receive (RXIR pin) Baud rate Error (into MCP2155)	—	—	± 1	%	
IR112	ERXBIT	Receive (RX pin) Baud rate Error (out of MCP2155) ⁽¹⁾	—	—	± 1	%	
IR113	T _{TXRF}	RX pin rise time and fall time	—	—	25	ns	

Note 1: This error is not additive to IR111 parameter.

MCP2155

FIGURE 4-8: TXIR WAVEFORMS

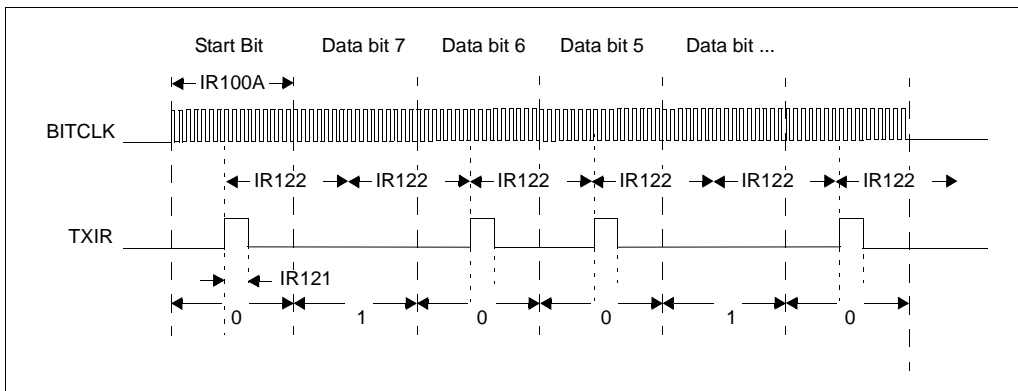

TABLE 4-8: TXIR REQUIREMENTS

AC Characteristics			Standard Operating Conditions (unless otherwise specified)				
			Operating Temperature: $-40^{\circ}\text{C} \leq T_A \leq +85^{\circ}\text{C}$ (industrial)				
			Operating Voltage VDD range is described in Section 4.1				
Param. No.	Sym	Characteristic	Min	Typ	Max	Units	Conditions
IR100A	TTXIRBIT	Transmit Baud Rate	1152	—	1152	Tosc	BAUD = 9600
			576	—	576	Tosc	BAUD = 19200
			288	—	288	Tosc	BAUD = 38400
			192	—	192	Tosc	BAUD = 57600
			96	—	96	Tosc	BAUD = 115200
IR121	TTXIRPW	TXIR pulse width	24	—	24	Tosc	
IR122	TTXIRP	TXIR bit period ⁽¹⁾	—	16	—	TBITCLK	

Note 1: TBITCLK = TTXBIT/16.

MCP2155

FIGURE 4-9: RXIR WAVEFORMS

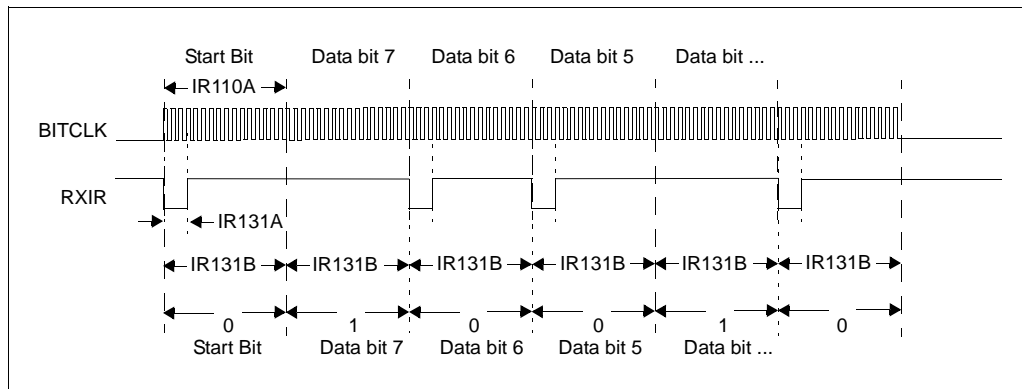

TABLE 4-9: RXIR REQUIREMENTS

AC Characteristics			Standard Operating Conditions (unless otherwise specified)				
			Operating Temperature: $-40^{\circ}\text{C} \leq T_A \leq +85^{\circ}\text{C}$ (industrial)				
			Operating Voltage VDD range is described in Section 4.1				
Param. No.	Sym	Characteristic	Min	Typ	Max	Units	Conditions
IR110A	TRXIRBIT	Receive Baud Rate	1152	—	1152	Tosc	BAUD = 9600
			576	—	576	Tosc	BAUD = 19200
			288	—	288	Tosc	BAUD = 38400
			192	—	192	Tosc	BAUD = 57600
			96	—	96	Tosc	BAUD = 115200
IR131A	TRXIRPW	RXIR pulse width	2	—	24	Tosc	
IR132	TRXIRP	RXIR bit period ⁽¹⁾	—	16	—	TBITCLK	

Note 1: TBITCLK = TRXBIT/16.



MCP2155

NOTES:

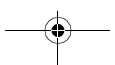
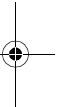
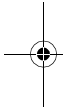

MCP2155

5.0 DC AND AC CHARACTERISTICS GRAPHS AND TABLES

Not available at this time.



MCP2155

NOTES:

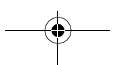
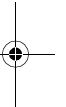
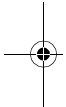
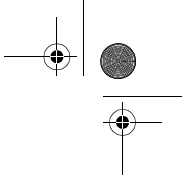

MCP2155

6.0 PACKAGING INFORMATION

6.1 Package Marking Information

18-Lead PDIP (300 mil)

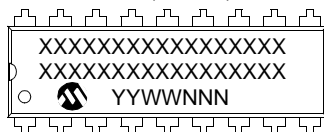

Example:



18-Lead SOIC (300 mil)

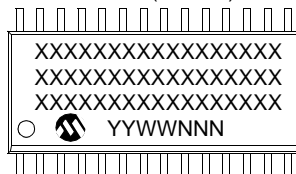

Example:

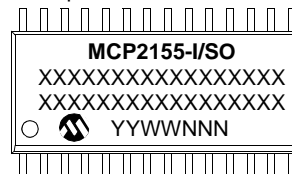

20-Lead SSOP (209 mil, 5.30 mm)

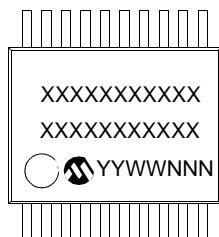

Example:

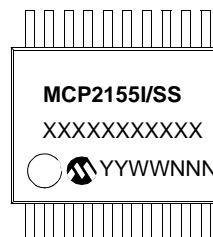

Legend: XX...X Customer-specific information
 Y Year code (last digit of calendar year)
 YY Year code (last 2 digits of calendar year)
 WW Week code (week of January 1 is week '01')
 NNN Alphanumeric traceability code
 (e3) Pb-free JEDEC designator for Matte Tin (Sn)
 * This package is Pb-free. The Pb-free JEDEC designator (e3) can be found on the outer packaging for this package.

Note: In the event the full Microchip part number cannot be marked on one line, it will be carried over to the next line, thus limiting the number of available characters for customer-specific information.

MCP2155

18-Lead Plastic Dual In-line (P) – 300 mil (PDIP)

Note: For the most current package drawings, please see the Microchip Packaging Specification located at <http://www.microchip.com/packaging>

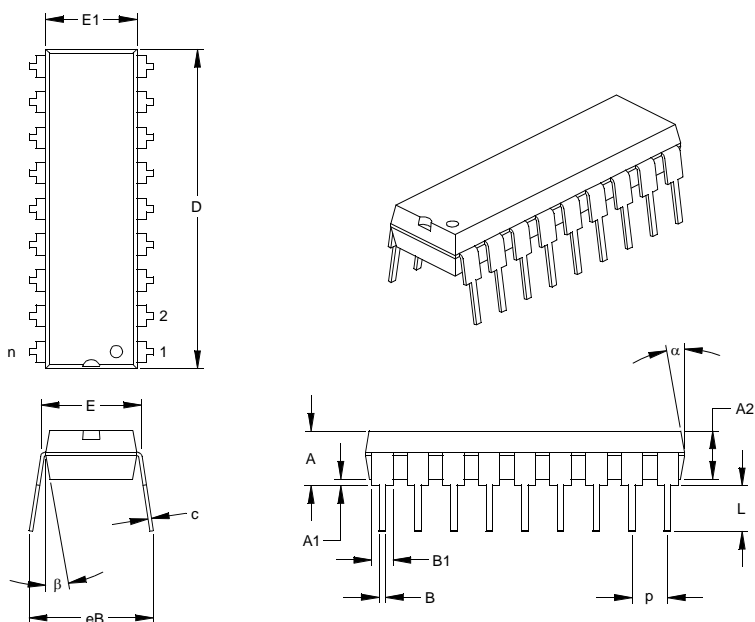

Dimension Limits	Units	INCHES*			MILLIMETERS		
		MIN	NOM	MAX	MIN	NOM	MAX
Number of Pins	n		18			18	
Pitch	p		.100			2.54	
Top to Seating Plane	A	.140	.155	.170	3.56	3.94	4.32
Molded Package Thickness	A2	.115	.130	.145	2.92	3.30	3.68
Base to Seating Plane	A1	.015			0.38		
Shoulder to Shoulder Width	E	.300	.313	.325	7.62	7.94	8.26
Molded Package Width	E1	.240	.250	.260	6.10	6.35	6.60
Overall Length	D	.890	.898	.905	22.61	22.80	22.99
Tip to Seating Plane	L	.125	.130	.135	3.18	3.30	3.43
Lead Thickness	c	.008	.012	.015	0.20	0.29	0.38
Upper Lead Width	B1	.045	.058	.070	1.14	1.46	1.78
Lower Lead Width	B	.014	.018	.022	0.36	0.46	0.56
Overall Row Spacing	§ eB	.310	.370	.430	7.87	9.40	10.92
Mold Draft Angle Top	α	5	10	15	5	10	15
Mold Draft Angle Bottom	β	5	10	15	5	10	15

* Controlling Parameter
 § Significant Characteristic

Notes:
 Dimensions D and E1 do not include mold flash or protrusions. Mold flash or protrusions shall not exceed .010" (0.254mm) per side.
 JEDEC Equivalent: MS-001
 Drawing No. C04-007

MCP2155

18-Lead Plastic Small Outline (SO) – Wide, 300 mil (SOIC)

Note: For the most current package drawings, please see the Microchip Packaging Specification located at <http://www.microchip.com/packaging>

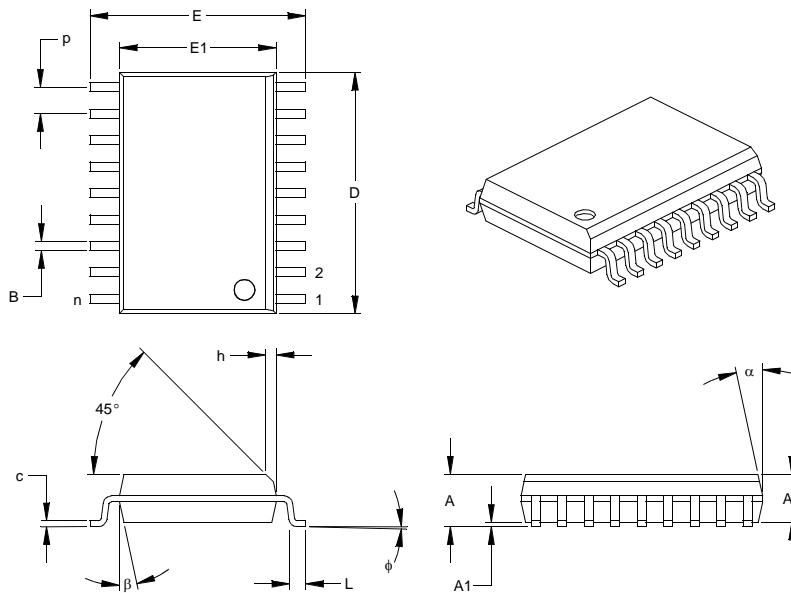

Dimension	Limits	INCHES*			MILLIMETERS		
		MIN	NOM	MAX	MIN	NOM	MAX
Number of Pins	n		18			18	
Pitch	p		.050			1.27	
Overall Height	A	.093	.099	.104	2.36	2.50	2.64
Molded Package Thickness	A2	.088	.091	.094	2.24	2.31	2.39
Standoff §	A1	.004	.008	.012	0.10	0.20	0.30
Overall Width	E	.394	.407	.420	10.01	10.34	10.67
Molded Package Width	E1	.291	.295	.299	7.39	7.49	7.59
Overall Length	D	.446	.454	.462	11.33	11.53	11.73
Chamfer Distance	h	.010	.020	.029	0.25	0.50	0.74
Foot Length	L	.016	.033	.050	0.41	0.84	1.27
Foot Angle	φ	0	4	8	0	4	8
Lead Thickness	c	.009	.011	.012	0.23	0.27	0.30
Lead Width	B	.014	.017	.020	0.36	0.42	0.51
Mold Draft Angle Top	α	0	12	15	0	12	15
Mold Draft Angle Bottom	β	0	12	15	0	12	15

* Controlling Parameter
 § Significant Characteristic

Notes:

Dimensions D and E1 do not include mold flash or protrusions. Mold flash or protrusions shall not exceed .010" (0.254mm) per side.
 JEDEC Equivalent: MS-013
 Drawing No. C04-051

MCP2155

20-Lead Plastic Shrink Small Outline (SS) – 209 mil, 5.30 mm (SSOP)

Note: For the most current package drawings, please see the Microchip Packaging Specification located at <http://www.microchip.com/packaging>

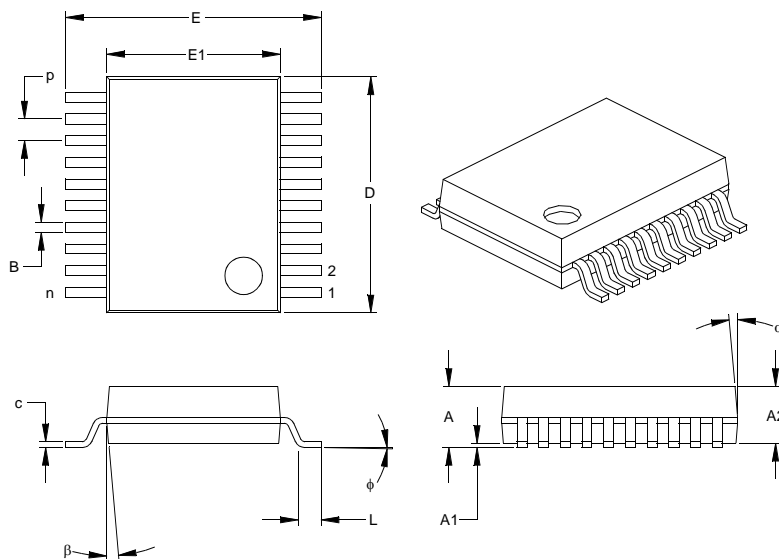

Dimension Limits	Units	INCHES*			MILLIMETERS		
		MIN	NOM	MAX	MIN	NOM	MAX
Number of Pins	n		20			20	
Pitch	p		.026			0.65	
Overall Height	A	.068	.073	.078	1.73	1.85	1.98
Molded Package Thickness	A2	.064	.068	.072	1.63	1.73	1.83
Standoff §	A1	.002	.006	.010	0.05	0.15	0.25
Overall Width	E	.299	.309	.322	7.59	7.85	8.18
Molded Package Width	E1	.201	.207	.212	5.11	5.25	5.38
Overall Length	D	.278	.284	.289	7.06	7.20	7.34
Foot Length	L	.022	.030	.037	0.56	0.75	0.94
Lead Thickness	c	.004	.007	.010	0.10	0.18	0.25
Foot Angle	φ	0	4	8	0.00	101.60	203.20
Lead Width	B	.010	.013	.015	0.25	0.32	0.38
Mold Draft Angle Top	α	0	5	10	0	5	10
Mold Draft Angle Bottom	β	0	5	10	0	5	10

* Controlling Parameter
 § Significant Characteristic

Notes:
 Dimensions D and E1 do not include mold flash or protrusions. Mold flash or protrusions shall not exceed .010" (0.254mm) per side.
 JEDEC Equivalent: MO-150
 Drawing No. C04-072

MCP2155

APPENDIX A: REVISION HISTORY

Revision A

This is a new data sheet

Revision K (January 2013)

Added a note to each package outline drawing.



MCP2155

NOTES:

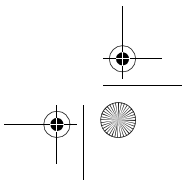
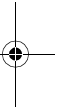
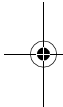
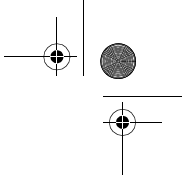

THE MICROCHIP WEB SITE

Microchip provides online support via our WWW site at www.microchip.com. This web site is used as a means to make files and information easily available to customers. Accessible by using your favorite Internet browser, the web site contains the following information:

- **Product Support** – Data sheets and errata, application notes and sample programs, design resources, user's guides and hardware support documents, latest software releases and archived software
- **General Technical Support** – Frequently Asked Questions (FAQ), technical support requests, online discussion groups, Microchip consultant program member listing
- **Business of Microchip** – Product selector and ordering guides, latest Microchip press releases, listing of seminars and events, listings of Microchip sales offices, distributors and factory representatives

CUSTOMER CHANGE NOTIFICATION SERVICE

Microchip's customer notification service helps keep customers current on Microchip products. Subscribers will receive e-mail notification whenever there are changes, updates, revisions or errata related to a specified product family or development tool of interest.

To register, access the Microchip web site at www.microchip.com. Under "Support", click on "Customer Change Notification" and follow the registration instructions.

CUSTOMER SUPPORT

Users of Microchip products can receive assistance through several channels:

- Distributor or Representative
- Local Sales Office
- Field Application Engineer (FAE)
- Technical Support

Customers should contact their distributor, representative or field application engineer (FAE) for support. Local sales offices are also available to help customers. A listing of sales offices and locations is included in the back of this document.

Technical support is available through the web site at: <http://microchip.com/support>

READER RESPONSE

It is our intention to provide you with the best documentation possible to ensure successful use of your Microchip product. If you wish to provide your comments on organization, clarity, subject matter, and ways in which our documentation can better serve you, please FAX your comments to the Technical Publications Manager at (480) 792-4150.

Please list the following information, and use this outline to provide us with your comments about this document.

TO: Technical Publications Manager Total Pages Sent _____

RE: Reader Response

From: Name _____

Company _____

Address _____

City / State / ZIP / Country _____

Telephone: (_____) _____ - _____ FAX: (_____) _____ - _____

Application (optional):

Would you like a reply? ___ Y ___ N

Device:

Literature Number: DS21690B

Questions:

1. What are the best features of this document?

2. How does this document meet your hardware and software development needs?

3. Do you find the organization of this document easy to follow? If not, why?

4. What additions to the document do you think would enhance the structure and subject?

5. What deletions from the document could be made without affecting the overall usefulness?

6. Is there any incorrect or misleading information (what and where)?

7. How would you improve this document?

MCP2155

PRODUCT IDENTIFICATION SYSTEM

To order or obtain information, e.g., on pricing or delivery, refer to the factory or the listed sales office.

PART NO.		X	/XX
Device	Temperature Range		Package
Examples: a) MCP2155-I/P = Industrial Temp., PDIP packaging b) MCP2155-I/SO = Industrial Temp., SOIC package c) MCP2155T-I/SS = Tape and Reel, Industrial Temp., SSOP package			
Device: MCP2155: Infrared Communications Controller MCP2155T: Infrared Communications Controller (Tape and Reel)			
Temperature Range: I = -40°C to +85°C			
Package: P = Plastic DIP (300 mil, Body), 18-lead SO = Plastic SOIC (300 mil, Body), 18-lead SS = Plastic SSOP (209 mil, Body), 20-lead			

Sales and Support

Data Sheets

Products supported by a preliminary Data Sheet may have an errata sheet describing minor operational differences and recommended workarounds. To determine if an errata sheet exists for a particular device, please contact one of the following:

1. Your local Microchip sales office
2. The Microchip Worldwide Site (www.microchip.com)

Please specify which device, revision of silicon and Data Sheet (include Literature #) you are using.

New Customer Notification System

Register on our web site (www.microchip.com/cn) to receive the most current information on our products.



MCP2155

NOTES:

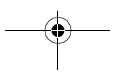
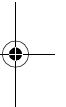
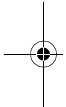

Note the following details of the code protection feature on Microchip devices:

- Microchip products meet the specification contained in their particular Microchip Data Sheet.
- Microchip believes that its family of products is one of the most secure families of its kind on the market today, when used in the intended manner and under normal conditions.
- There are dishonest and possibly illegal methods used to breach the code protection feature. All of these methods, to our knowledge, require using the Microchip products in a manner outside the operating specifications contained in Microchip's Data Sheets. Most likely, the person doing so is engaged in theft of intellectual property.
- Microchip is willing to work with the customer who is concerned about the integrity of their code.
- Neither Microchip nor any other semiconductor manufacturer can guarantee the security of their code. Code protection does not mean that we are guaranteeing the product as "unbreakable."

Code protection is constantly evolving. We at Microchip are committed to continuously improving the code protection features of our products. Attempts to break Microchip's code protection feature may be a violation of the Digital Millennium Copyright Act. If such acts allow unauthorized access to your software or other copyrighted work, you may have a right to sue for relief under that Act.

Information contained in this publication regarding device applications and the like is provided only for your convenience and may be superseded by updates. It is your responsibility to ensure that your application meets with your specifications. MICROCHIP MAKES NO REPRESENTATIONS OR WARRANTIES OF ANY KIND WHETHER EXPRESS OR IMPLIED, WRITTEN OR ORAL, STATUTORY OR OTHERWISE, RELATED TO THE INFORMATION, INCLUDING BUT NOT LIMITED TO ITS CONDITION, QUALITY, PERFORMANCE, MERCHANTABILITY OR FITNESS FOR PURPOSE. Microchip disclaims all liability arising from this information and its use. Use of Microchip devices in life support and/or safety applications is entirely at the buyer's risk, and the buyer agrees to defend, indemnify and hold harmless Microchip from any and all damages, claims, suits, or expenses resulting from such use. No licenses are conveyed, implicitly or otherwise, under any Microchip intellectual property rights.

Trademarks

The Microchip name and logo, the Microchip logo, dsPIC, FlashFlex, KEELOQ, KEELOQ logo, MPLAB, PIC, PICmicro, PICSTART, PIC³² logo, rPIC, SST, SST Logo, SuperFlash and UNI/O are registered trademarks of Microchip Technology Incorporated in the U.S.A. and other countries.

FilterLab, Hampshire, HI-TECH C, Linear Active Thermistor, MTP, SEEVAL and The Embedded Control Solutions Company are registered trademarks of Microchip Technology Incorporated in the U.S.A.

Silicon Storage Technology is a registered trademark of Microchip Technology Inc. in other countries.

Analog-for-the-Digital Age, Application Maestro, BodyCom, chipKIT, chipKIT logo, CodeGuard, dsPICDEM, dsPICDEM.net, dsPICworks, dsSPEAK, ECAN, ECONOMONITOR, FanSense, HI-TIDE, In-Circuit Serial Programming, ICSP, Mindi, MiWi, MPASM, MPF, MPLAB Certified logo, MPLIB, MPLINK, mTouch, Omniclient Code Generation, PICC, PICC-18, PICDEM, PICDEM.net, PICkit, PICtail, REAL ICE, rLAB, Select Mode, SQI, Serial Quad I/O, Total Endurance, TSHARC, UniWinDriver, WiperLock, ZENA and Z-Scale are trademarks of Microchip Technology Incorporated in the U.S.A. and other countries.

SQTP is a service mark of Microchip Technology Incorporated in the U.S.A.

GestIC and ULPP are registered trademarks of Microchip Technology Germany II GmbH & Co. & KG, a subsidiary of Microchip Technology Inc., in other countries.

All other trademarks mentioned herein are property of their respective companies.

© 2001-2013, Microchip Technology Incorporated, Printed in the U.S.A., All Rights Reserved.

 Printed on recycled paper.

ISBN: 9781620768914

**QUALITY MANAGEMENT SYSTEM
CERTIFIED BY DNV
= ISO/TS 16949 =**

Microchip received ISO/TS-16949:2009 certification for its worldwide headquarters, design and wafer fabrication facilities in Chandler and Tempe, Arizona; Gresham, Oregon and design centers in California and India. The Company's quality system processes and procedures are for its PIC® MCUs and dsPIC® DSCs, KEELOQ® code hopping devices, Serial EEPROMs, microperipherals, nonvolatile memory and analog products. In addition, Microchip's quality system for the design and manufacture of development systems is ISO 9001:2000 certified.



Worldwide Sales and Service

AMERICAS

Corporate Office
2355 West Chandler Blvd.
Chandler, AZ 85224-6199
Tel: 480-792-7200
Fax: 480-792-7277
Technical Support:
<http://www.microchip.com/support>
Web Address:
www.microchip.com

Atlanta

Duluth, GA
Tel: 678-957-9614
Fax: 678-957-1455

Boston

Westborough, MA
Tel: 774-760-0087
Fax: 774-760-0088

Chicago

Itasca, IL
Tel: 630-285-0071
Fax: 630-285-0075

Cleveland

Independence, OH
Tel: 216-447-0464
Fax: 216-447-0643

Dallas

Addison, TX
Tel: 972-818-7423
Fax: 972-818-2924

Detroit

Farmington Hills, MI
Tel: 248-538-2250
Fax: 248-538-2260

Indianapolis

Noblesville, IN
Tel: 317-773-8323
Fax: 317-773-5453

Los Angeles

Mission Viejo, CA
Tel: 949-462-9523
Fax: 949-462-9608

Santa Clara

Santa Clara, CA
Tel: 408-961-6444
Fax: 408-961-6445

Toronto

Mississauga, Ontario,
Canada
Tel: 905-673-0699
Fax: 905-673-6509

ASIA/PACIFIC

Asia Pacific Office
Suites 3707-14, 37th Floor
Tower 6, The Gateway
Harbour City, Kowloon
Hong Kong
Tel: 852-2401-1200
Fax: 852-2401-3431

Australia - Sydney

Tel: 61-2-9868-6733
Fax: 61-2-9868-6755

China - Beijing

Tel: 86-10-8569-7000
Fax: 86-10-8528-2104

China - Chengdu

Tel: 86-28-8665-5511
Fax: 86-28-8665-7889

China - Chongqing

Tel: 86-23-8980-9588
Fax: 86-23-8980-9500

China - Hangzhou

Tel: 86-571-2819-3187
Fax: 86-571-2819-3189

China - Hong Kong SAR

Tel: 852-2943-5100
Fax: 852-2401-3431

China - Nanjing

Tel: 86-25-8473-2460
Fax: 86-25-8473-2470

China - Qingdao

Tel: 86-532-8502-7355
Fax: 86-532-8502-7205

China - Shanghai

Tel: 86-21-5407-5533
Fax: 86-21-5407-5066

China - Shenyang

Tel: 86-24-2334-2829
Fax: 86-24-2334-2393

China - Shenzhen

Tel: 86-755-8864-2200
Fax: 86-755-8203-1760

China - Wuhan

Tel: 86-27-5980-5300
Fax: 86-27-5980-5118

China - Xian

Tel: 86-29-8833-7252
Fax: 86-29-8833-7256

China - Xiamen

Tel: 86-592-2388138
Fax: 86-592-2388130

China - Zhuhai

Tel: 86-756-3210040
Fax: 86-756-3210049

ASIA/PACIFIC

India - Bangalore
Tel: 91-80-3090-4444
Fax: 91-80-3090-4123

India - New Delhi

Tel: 91-11-4160-8631
Fax: 91-11-4160-8632

India - Pune

Tel: 91-20-2566-1512
Fax: 91-20-2566-1513

Japan - Osaka

Tel: 81-6-6152-7160
Fax: 81-6-6152-9310

Japan - Tokyo

Tel: 81-3-6880-3770
Fax: 81-3-6880-3771

Korea - Daegu

Tel: 82-53-744-4301
Fax: 82-53-744-4302

Korea - Seoul

Tel: 82-2-554-7200
Fax: 82-2-558-5932 or
82-2-558-5934

Malaysia - Kuala Lumpur

Tel: 60-3-6201-9857
Fax: 60-3-6201-9859

Malaysia - Penang

Tel: 60-4-227-8870
Fax: 60-4-227-4068

Philippines - Manila

Tel: 63-2-634-9065
Fax: 63-2-634-9069

Singapore

Tel: 65-6334-8870
Fax: 65-6334-8850

Taiwan - Hsin Chu

Tel: 886-3-5778-366
Fax: 886-3-5770-955

Taiwan - Kaohsiung

Tel: 886-7-213-7828
Fax: 886-7-330-9305

Taiwan - Taipei

Tel: 886-2-2508-8600
Fax: 886-2-2508-0102

Thailand - Bangkok

Tel: 66-2-694-1351
Fax: 66-2-694-1350

EUROPE

Austria - Wels

Tel: 43-7242-2244-39
Fax: 43-7242-2244-393

Denmark - Copenhagen

Tel: 45-4450-2828
Fax: 45-4485-2829

France - Paris

Tel: 33-1-69-53-63-20
Fax: 33-1-69-30-90-79

Germany - Munich

Tel: 49-89-627-144-0
Fax: 49-89-627-144-44

Italy - Milan

Tel: 39-0331-742611
Fax: 39-0331-466781

Netherlands - Drunen

Tel: 31-416-690399
Fax: 31-416-690340

Spain - Madrid

Tel: 34-91-708-08-90
Fax: 34-91-708-08-91

UK - Wokingham

Tel: 44-118-921-5869
Fax: 44-118-921-5820

11/29/12

Looking for pricing, stock, or lifecycle information?

Click below to explore more details on WIN SOURCE:

- ⊖ [View MCP2155-I/SS on WIN SOURCE](#)
- ⊖ [Microchip Technology Information](#)

Optimize Your Supply Chain with WIN SOURCE Solutions

- ✓ Global Sourcing Solution
- ✓ Obsolete Management
- ✓ Cost Control Management
- ✓ Shortage Management
- ✓ Alternative Solution
- ✓ Excess Inventory Management