

Infrared Encoder/Decoder

Features

- Supports with IrDA[®] Physical Layer Specification (version 1.3)
- UART to IR Encoder/Decoder
 - Interfaces with IrDA Compliant Transceivers
 - Used with any UART, including standard 16550 UART and microcontroller UART
- Transmit/Receive formats supported:
 - 1.63 μ s
- Hardware or Software Baud rate selection
 - Up to IrDA standard 115.2 kbaud operation
 - Up to 312.5 kbaud operation (at 20 MHz)
 - Low power mode
- Pb-free packaging

CMOS Technology

- Low-power, high-speed CMOS technology
- Fully static design
- Low voltage operation
- Commercial and Industrial temperature ranges
- Low power consumption
 - < 1 mA @ 3.3V, 8 MHz (typical)
 - 3 mA typical @ 5.0V when disabled

Pin Diagrams

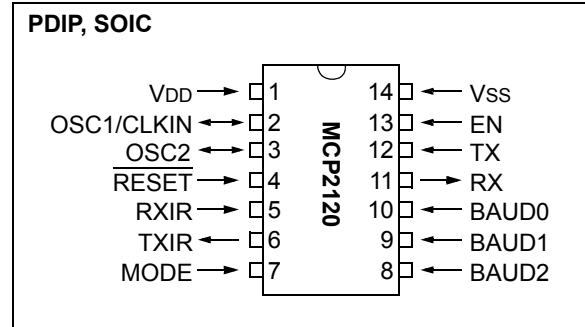

Block Diagram

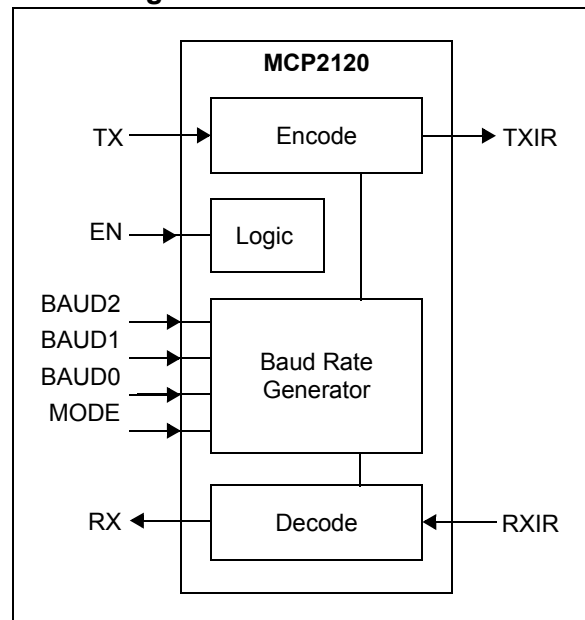

MCP2120

NOTES:

1.0 DEVICE OVERVIEW

This document contains device specific information for the following device:

- MCP2120

This device is a low-cost, high-performance, fully-static infrared encoder/decoder. This device sits between a UART and an infrared (IR) optical transceiver.

The data received from a standard UART is encoded (modulated), and output as electrical pulses to the IR Transceiver. The IR Transceiver also receives data which it outputs as electrical pulses. The MCP2120 decodes (demodulates) these electrical pulses and then the data is transmitted by the MCP2120 UART. This modulation and demodulation method is performed in accordance with the IrDA standard.

Typically a microcontroller interfaces to the IR encoder/decoder.

Infrared communication is a wireless two-way data connection using infrared light generated by low-cost transceiver signaling technology. This provides reliable communication between two devices.

Infrared technology offers:

- Universal standard for connecting portable computing devices
- Easy, effortless implementation
- Economical alternative to other connectivity solutions
- Reliable, high speed connection
- Safe to use in any environment; can even be used during air travel
- Eliminates the hassle of cables
- Allows PC's and non-PC's to communicate to each other
- Enhances mobility by allowing users to easily connect

1.1 Applications

The MCP2120 is a stand-alone IrDA Encoder/Decoder product. Figure 1-1 shows a typical application block diagram. Table 1-2 shows the pin definitions in the user (normal) mode of operation.

TABLE 1-1: MCP2120 FEATURES OVERVIEW

Features	MCP2120
Serial Communications:	UART, IR
Baud Rate Selection:	Hardware/Software
Low Power Mode:	Yes
Resets: (and Delays)	Wake-up (DRT)
Packages:	14-pin DIP 14-pin SOIC

FIGURE 1-1: System Block Diagram

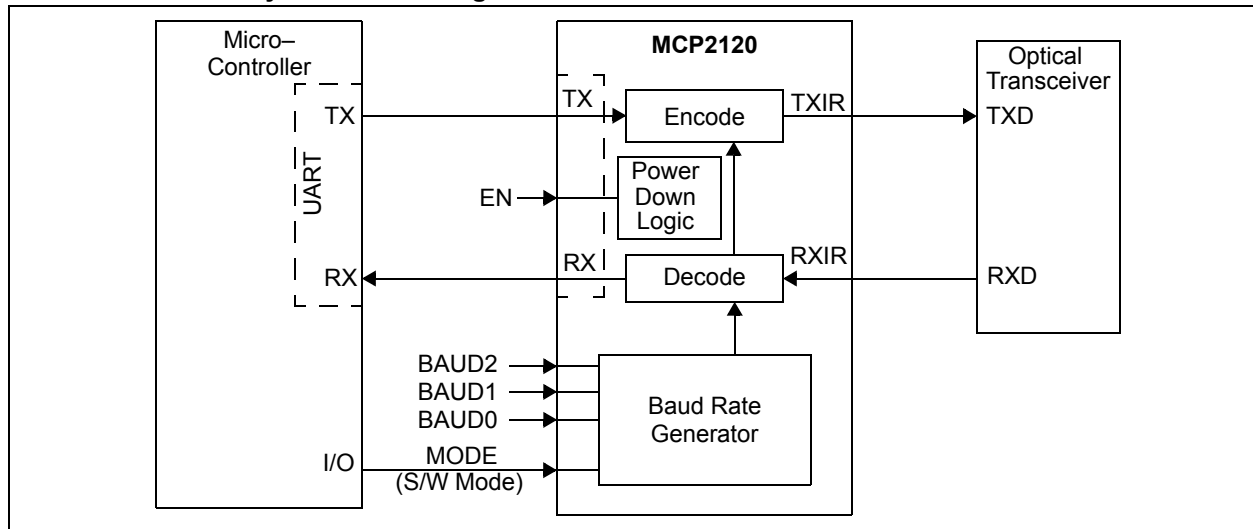

MCP2120

TABLE 1-2: PIN DESCRIPTION USER MODE

Pin Name	Pin Number		Pin Type	Buffer Type	Description
	PDIP	SOIC			
VDD	1	1	—	P	Positive supply for logic and I/O pins
OSC1/CLKIN	2	2	I	CMOS	Oscillator crystal input/external clock source input
OSC2	3	3	O	—	Oscillator crystal Output
RESET	4	4	I	ST	Resets the Device
RXIR	5	5	I	ST	Asynchronous receive from infrared transceiver
TXIR	6	6	O	—	Asynchronous transmit to infrared transceiver
MODE	7	7	I	TTL	Selects the device mode (Data/Command) for Software Baud Rate operation. For more information see Section 2.4.1.2 “Software Selection” .
BAUD2	8	8	I	TTL	BAUD2:BAUD0 specify the Baud rate of the device, or if the device operates in Software Baud Rate mode. For more information see Section 2.4.1 “Baud Rate” .
BAUD1	9	9	I	TTL	
BAUD0	10	10	I	TTL	
RX	11	11	O	—	Asynchronous transmit to controller UART
TX	12	12	I	TTL	Asynchronous receive from controller UART
EN	13	13	I	—	Device Enable.
Vss	14	14	—	P	Ground reference for logic and I/O pins

Legend: TTL = TTL compatible input
I = Input
P = Power

ST = Schmitt Trigger input with CMOS levels
O = Output
CMOS = CMOS compatible input

2.0 DEVICE OPERATION

The MCP2120 is a low cost infrared Encoder/Decoder. The baud rate is user selectable to standard IrDA baud rates between 9600 baud to 115.2 kbaud. The maximum baud rate is 312.5 kbaud.

2.1 Power-up

Any time that the device is powered up, the Device Reset Timer delay ([parameter 32](#)) must occur before any communication with the device is initiated. This is from both the infrared transceiver side as well as the controller UART interface.

2.2 Device Reset

The MCP2120 is forced into the reset state when the RESET pin is in the low state. After the RESET pin is brought to a high state, the Device Reset Timer occurs. Once the DRT times out, normal operation occurs.

2.3 Bit Clock

The device crystal is used to derive the communication bit clock (BITCLK). There are 16 BITCLKs for each bit time. The BITCLKs are used for the generation of the Start bit and the eight data bits. The Stop bit uses the BITCLK when the data is transmitted (not for reception).

This clock is a fixed frequency, and has minimal variation in frequency (specified by crystal manufacturer).

2.4 UART Interface

The UART interface communicates with the "controller". This interface is a Half duplex interface, meaning that the system is either transmitting or receiving, but not both at the same time.

2.4.1 BAUD RATE

The baud rate for the MCP2120 can be configured either by the state of three hardware pins (BAUD2, BAUD1, and BAUD0) or through software selection.

2.4.1.1 Hardware Selection

Three device pins are used to select the baud rate that the MCP2120 will transmit and receive data. These pins are called BAUD2, BAUD1, and BAUD0. There is one pin state (device mode) where the application software can specify the baud rate. [Table 2-1](#) shows the baud rate configurations.

TABLE 2-1: HARDWARE BAUD RATE SELECTION VS. FREQUENCY

BAUD2:BAUD0	Frequency (MHz)							Bit Rate
	0.6144 ⁽¹⁾	2.000	3.6864	4.9152	7.3728	14.7456 ⁽²⁾	20.000 ⁽²⁾	
000	800	2604	4800	6400	9600	19200	26042	Fosc / 768
001	1600	5208	9600	12800	19200	38400	52083	Fosc / 384
010	3200	10417	19200	25600	38400	78600	104167	Fosc / 192
011	4800	15625	28800	38400	57600	115200	156250	Fosc / 128
100	9600	31250	57600	78600	115200	230400	312500	Fosc / 64

Note 1: An external clock is recommended for frequencies below 2 MHz.

2: For frequencies above 7.5 MHz, the TXIR pulse width ([parameter IR121](#)) will be shorter than the minimum pulse width of 1.6 μ s in the IrDA standard specification.

MCP2120

2.4.1.2 Software Selection

When the BAUD2:BAUD0 pins are configured as '111' the MCP2120 defaults to a baud rate of $F_{osc} / 768$.

To place the MCP2120 into Command Mode, the MODE pin must be at a low level. When in this mode, any data that is received by the MCP2120's UART is "echoed" back to the controller and no encoding/decoding occurs. The echoed data will be skewed less than 1 bit time (see [parameter IR141](#)). When the MODE pin goes high, the device is returned to Data Mode where the encoder/decoder is in operation.

[Table 2-2](#) shows the software hex commands to configure the MCP2120's baud rate.

The MCP2120 receives data bytes at the existing baud rate. When the change baud rate command (0x11) is received, the last valid baud rate value received becomes the new baud rate. The new baud rate is effective after the stop bit of the echoed data. [Figure 2-2](#) shows this sequence.

2.4.2 TRANSMITTING

When the controller sends serial data to the MCP2120, the baud rates are required to match.

There will be some jitter on the detection of the high to low edge of the start bit. This jitter will affect the placement of the encoded start bit. All subsequent bits will be 16 BITCLK times later.

2.4.3 RECEIVING

When the controller receives serial data from the MCP2120, the baud rates are required to match.

There will be some jitter on the detection of the high to low edge of the start bit. This jitter will affect the placement of the decoded Start bit. All subsequent bits will be 16 BITCLK times later.

FIGURE 2-1: Data/Command Mode Flow

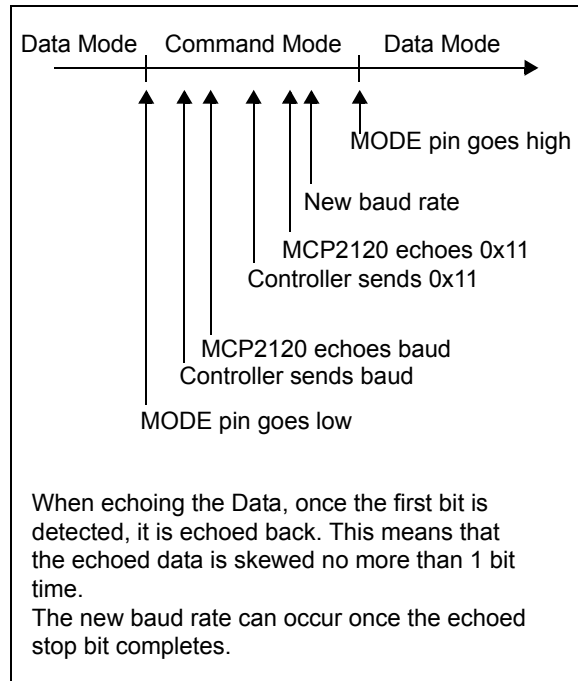

TABLE 2-2: SOFTWARE BAUD RATE SELECTION VS. FREQUENCY

Hex Command ^(3, 4)	Frequency (MHz)							Bit Rate
	0.6144 ⁽¹⁾	2.000	3.6864	4.9152	7.3728	14.7456 ⁽²⁾	20.000 ⁽²⁾	
0x87	800	2604	4800	6400	9600	19200	26042	$F_{osc} / 768$
0x8B	1600	5208	9600	12800	19200	38400	52083	$F_{osc} / 384$
0x85	3200	10417	19200	25600	38400	78600	104167	$F_{osc} / 192$
0x83	4800	15625	28800	38400	57600	115200	156250	$F_{osc} / 128$
0x81	9600	31250	57600	78600	115200	230400	312500	$F_{osc} / 64$

- Note 1:** An external clock is recommended for frequencies below 2 MHz.
- Note 2:** For frequencies above 7.3728 MHz, the TXIR pulse width ([parameter IR121](#)) will be shorter than the 1.6 μ s IrDA standard specification.
- Note 3:** Command 0x11 is used to change to the new baud rate.
- Note 4:** All other command codes are reserved for possible future use.

2.5 Modulation

When the UART receives data to be transmitted, the data needs to be modulated. This modulated signal drives the IR transceiver module. Figure 2-2 shows the encoding of the modulated signal.

Each bit time is comprised of 16-bit clocks. If the value to be transmitted (as determined by the TX pin) is a logic low, then the TXIR pin will output a low level for 7-bit clock cycles, a logic high level for 3-bit clock cycles, and then the remaining 6-bit clock cycles will be low. If the value to transmit is a logic high, then the TXIR pin will output a low level for the entire 16-bit clock cycles.

2.6 Demodulation

The modulated signal from the IR transceiver module needs to be demodulated to form the received data. As demodulation occurs, the bit value is placed on the RX pin in UART format. Figure 2-3 shows the decoding of the modulated signal.

Each bit time is comprised of 16 bit clocks. If the value to be received is a logic low, then the RXIR pin will be a low level for the first 3-bit clock cycles, and then the remaining 13-bit clock cycles will be high. If the value to be received is a logic high, then the RXIR pin will be a high level for the entire 16-bit clock cycles. The level on the RX pin will be in the appropriate state for the entire 16 clock cycles.

FIGURE 2-2: Encoding

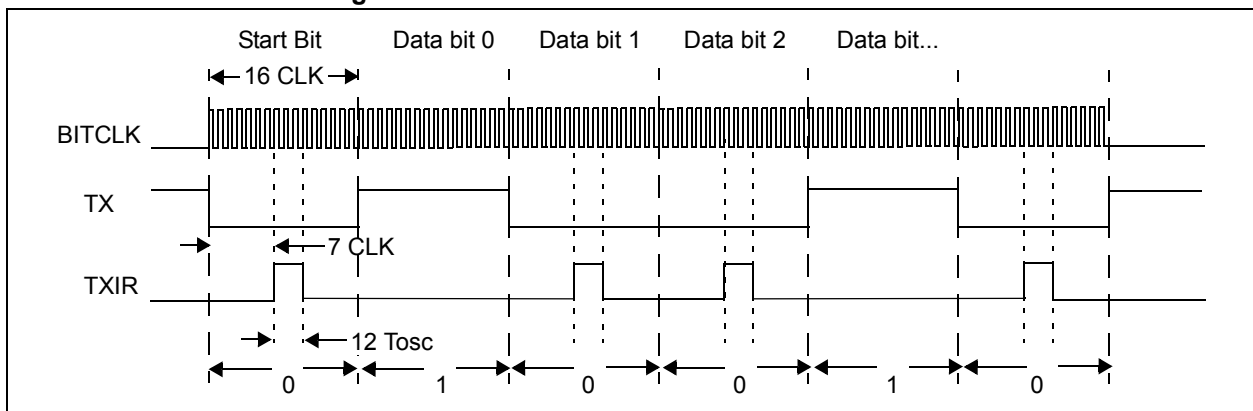
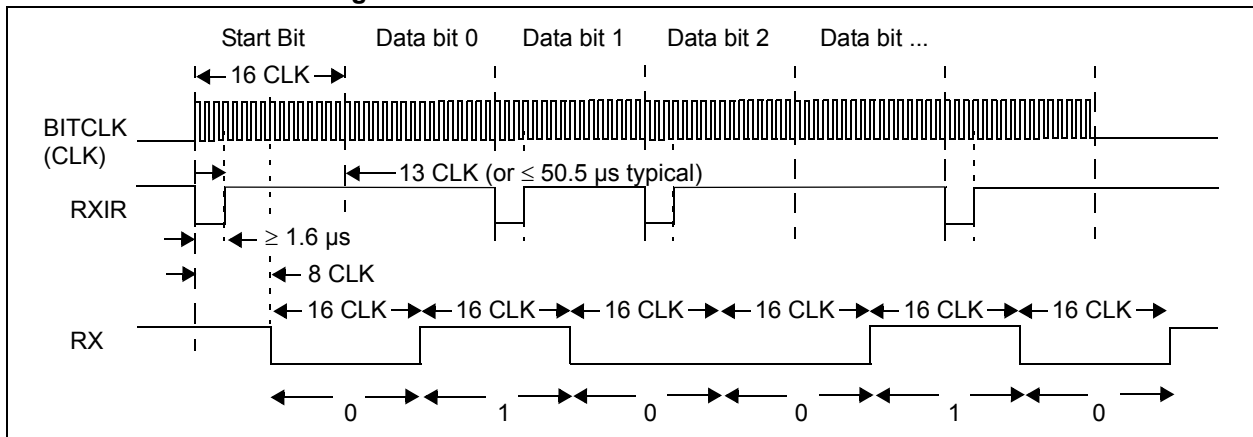

FIGURE 2-3: Decoding



MCP2120

2.7 Encoding/Decoding Jitter and Offset

Figure 2-4 shows the jitter and offset that is possible on the RX pin and the TXIR pin.

Jitter is the possible variation of the desired edge.

Offset is the propagation delay of the input signal (RXIR or TX) to the output signal (RX or TXIR).

The first bit on the output pin (on RX or TXIR) will show jitter compared to the input pin (RXIR or TX), but all remaining bits will be a constant distance.

2.8 Minimizing Power

The device can be placed in a low power mode by disabling the device (holding the EN pin at the low state). The internal state machine is monitoring this pin for a low level, and once this is detected the device is disabled and enters into a low power state.

2.8.1 RETURNING TO OPERATION

When the device is disabled, the device is in a low power state. When the EN pin is brought to a high level, the device will return to the operating mode. The device requires a delay of 1000 T_{osc} before data may be transmitted or received.

FIGURE 2-4: Effects of Jitter and Offset

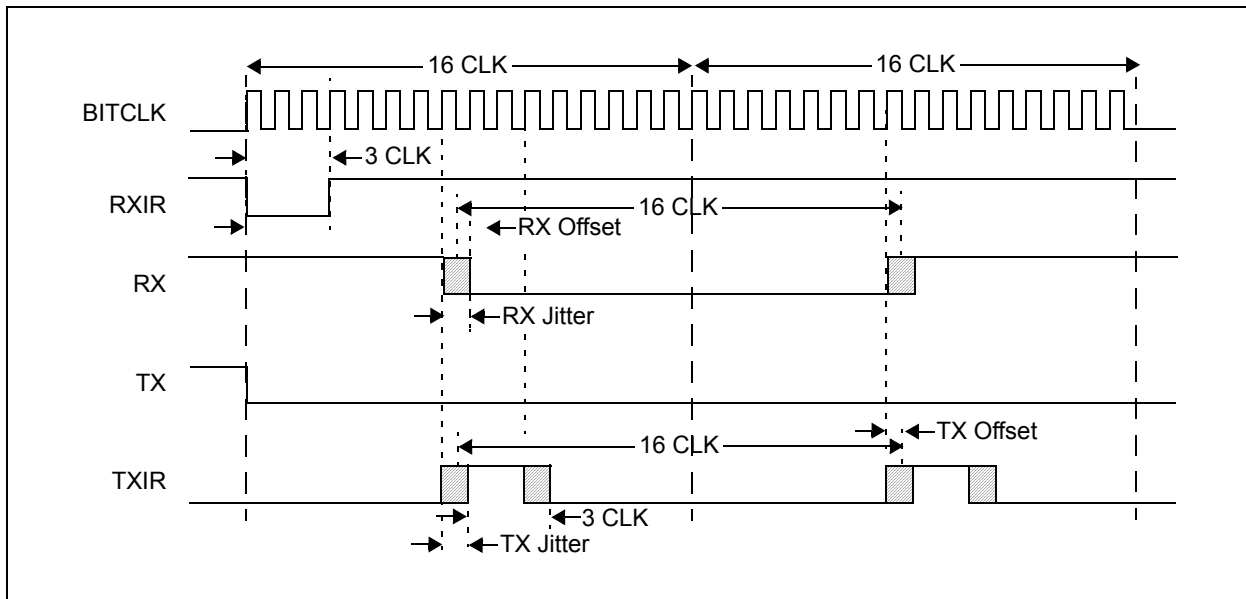

3.0 DEVELOPMENT TOOLS

The MCP212X Developer's Daughter Board is used to evaluate and demonstrate the MCP2122 or the MCP2120 IrDA® Standard Encoder/Decoder devices.

A header allows the MCP212X Developer's Daughter Board to be jumpered easily into systems for development purposes.

The MCP212X Developer's Daughter Board is designed to interface to several of the "new" low cost PIC® Demo Boards. These include the PICDEM HPC Explorer Demo board, the PICDEM FS USB Demo board, and the PICDEM LCD Demo board.

When the MCP212X Developer's Daughter Board is used in conjunction with the PICDEM HPC Explorer Demo board, the MCP212x can be connected to either of the PIC18F8772's two UARTs or the RX and TX signals can be "crossed" so the MCP212x device can communicate directly out the PICDEM HPC Explorer Demo Board's UART (DB-9).

The MCP2120/MCP2150 Developer's Kit has been obsoleted but if you have access to one of these kits, it can be used to demonstrate the operation of the MCP2120.

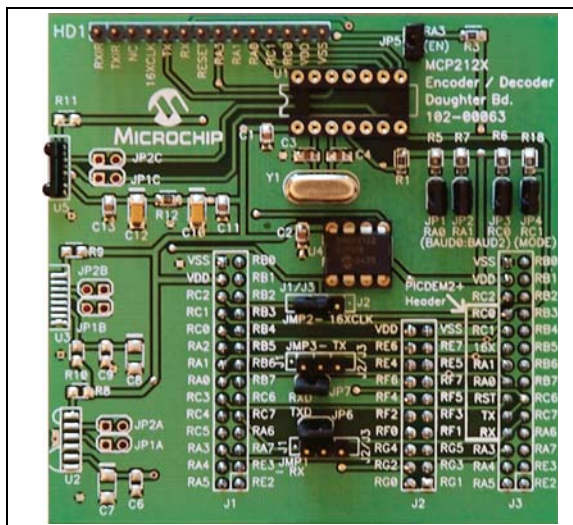

Features:

- 8-pin socket for installation of MCP2122 (installed) and 14-pin socket for installation of MCP2120
- Three Optical Transceiver circuits (1 installed)
- Headers to interface to low cost PICDEM Demo Boards, including:
 - • PICDEM™ HPC Explorer Demo Board
 - • PICDEM™ LCD Demo Board
 - • PICDEM™ FS USB Demo Board
 - • PICDEM™ 2 Plus Demo Board
- Headers to easily connect to the user's embedded system
- Jumpers to select routing of MCP212X signals to the PICDEM™ Demo Board Headers
- Jumpers to configure the operating mode of the board

MCP2120

NOTES:

4.0 ELECTRICAL CHARACTERISTICS

Absolute Maximum Ratings†

Ambient Temperature under bias	-40°C to +125°C
Storage Temperature	-65°C to +150°C
Voltage on VDD with respect to VSS	0 to +7V
Voltage on RESET with respect to VSS	0 to +14V
Voltage on all other pins with respect to VSS	-0.6V to (VDD + 0.6V)
Total Power Dissipation ⁽¹⁾	700 mW
Max. Current out of VSS pin	150 mA
Max. Current into VDD pin	125 mA
Input Clamp Current, I _{IK} (V _I < 0 or V _I > VDD)	±20 mA
Output Clamp Current, I _{OK} (V _O < 0 or V _O > VDD).....	±20 mA
Max. Output Current sunk by any Output pin.....	25 mA
Max. Output Current sourced by any Output pin.....	25 mA

Note 1: Power Dissipation is calculated as follows:

$$P_{DIS} = V_{DD} \times \{I_{DD} - \sum I_{OH}\} + \sum \{(V_{DD} - V_{OH}) \times I_{OH}\} + \sum (V_{OL} \times I_{OL})$$

†NOTICE: Stresses above those listed under "Maximum Ratings" may cause permanent damage to the device. This is a stress rating only and functional operation of the device at those or any other conditions above those indicated in the operation listings of this specification is not implied. Exposure to maximum rating conditions for extended periods may affect device reliability.

MCP2120

FIGURE 4-1: Voltage-Frequency Graph, $-40^{\circ}\text{C} \leq T_A \leq +85^{\circ}\text{C}$

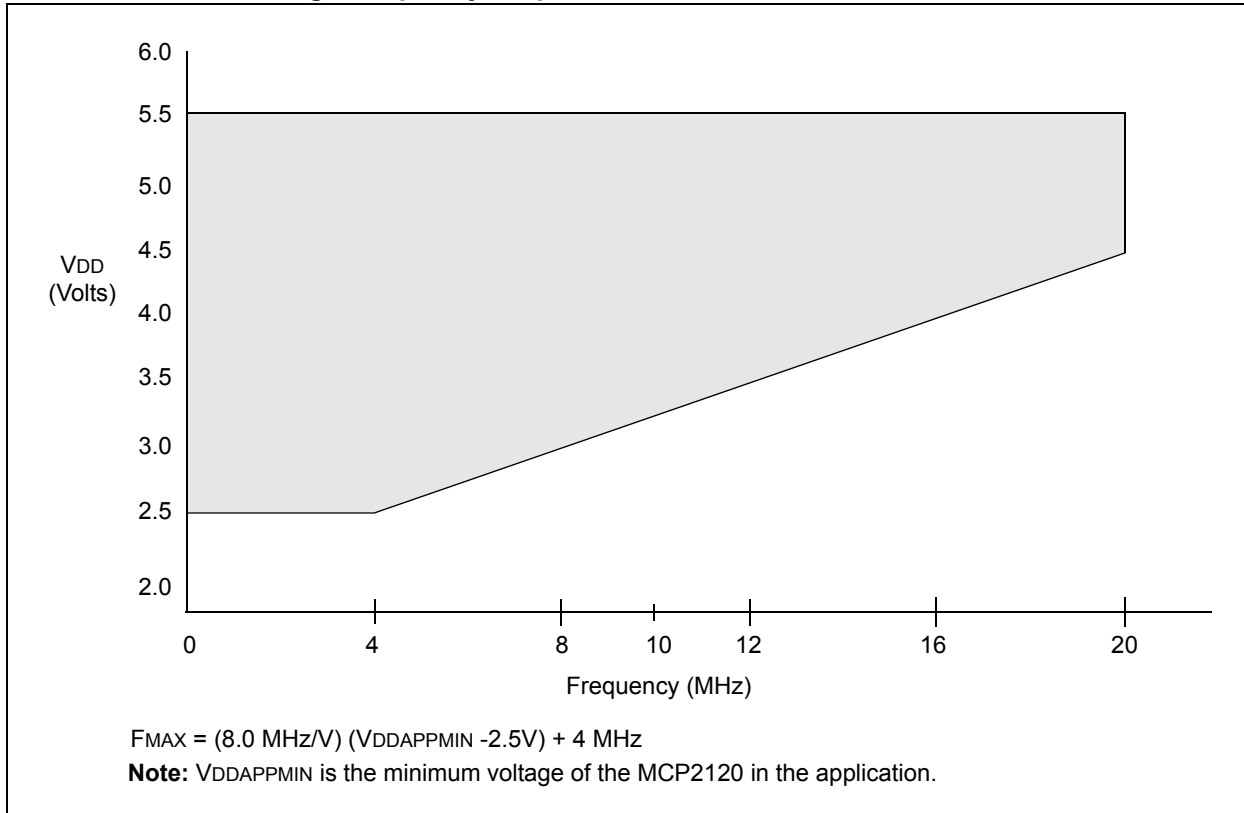

4.1 DC Characteristics

DC Characteristics			Standard Operating Conditions (unless otherwise specified) Operating Temperature $-40^{\circ}\text{C} \leq T_A \leq +85^{\circ}\text{C}$ (industrial)				
Param. No.	Sym	Characteristic	Min	Typ ⁽¹⁾	Max	Units	Conditions
D001	VDD	Supply Voltage	2.5	—	5.5	V	See Figure 4-1
D002	VDR	RAM Data Retention Voltage ⁽²⁾	2.5	—	—	V	Device Oscillator/Clock stopped
D003	VPOR	VDD Start Voltage to ensure Power-on Reset	—	VSS	—	V	
D004	SVDD	VDD Rise Rate to ensure Power-on Reset	0.05	—	—	V/ms	
D010	IDD	Supply Current ⁽³⁾	—	0.8	1.4	mA	FOSC = 4 MHz, VDD = 5.5V
			—	0.6	1.0	mA	FOSC = 4 MHz, VDD = 3.0V
			—	0.4	0.8	mA	FOSC = 4 MHz, VDD = 2.5V
			—	3	7	mA	FOSC = 10 MHz, VDD = 3.0V
			—	4	12	mA	FOSC = 20 MHz, VDD = 4.5V
			—	4.5	16	mA	FOSC = 20 MHz, VDD = 5.5V
D020	IPD	Device Disabled Current ^(3, 4)	—	0.25	4	μA	VDD = 3.0V, $0^{\circ}\text{C} \leq T_A \leq +70^{\circ}\text{C}$
			—	0.25	3	μA	VDD = 2.5V, $0^{\circ}\text{C} \leq T_A \leq +70^{\circ}\text{C}$
			—	0.4	5.5	μA	VDD = 4.5V, $0^{\circ}\text{C} \leq T_A \leq +70^{\circ}\text{C}$
			—	3	8	μA	VDD = 5.5V, $-40^{\circ}\text{C} \leq T_A \leq +85^{\circ}\text{C}$

- Note 1:** Data in the Typical (“Typ”) column is based on characterization results at +25°C. This data is for design guidance only and is not tested.
- 2:** This is the limit to which VDD can be lowered without losing RAM data.
- 3:** The supply current is mainly a function of the operating voltage and frequency. Pin loading, pin rate, and temperature have an impact on the current consumption.
- a) The test conditions for all IDD measurements are made when device is enabled (EN pin is high):
 OSC1 = external square wave, from rail-to-rail; all input pins pulled to VSS, RXIR = VDD, RESET = VDD;
- b) When device is disabled (EN pin is low), the conditions for current measurements are the same.
- 4:** When the device is disabled (EN pin is low), current is measured with all input pins tied to VDD or VSS and the output pins driving a high or low level into infinite impedance.

MCP2120

DC Characteristics (Continued)

DC CHARACTERISTICS			Standard Operating Conditions (unless otherwise specified) Operating temperature $-40^{\circ}\text{C} \leq T_A \leq +85^{\circ}\text{C}$ (industrial) Operating voltage V_{DD} range as described in DC spec Section 4.1 “DC Characteristics” .				
Param No.	Sym	Characteristic	Min	Typ	Max	Units	Conditions
D030 D030A D031 D032 D033	V_{IL}	Input Low Voltage Input pins with TTL buffer with Schmitt Trigger buffer $\overline{\text{RESET}}$, RXIR OSC1	V_{SS} V_{SS} V_{SS} V_{SS} V_{SS}	— — — — —	0.8V 0.15 V_{DD} 0.2 V_{DD} 0.2 V_{DD} 0.3 V_{DD}	V V V V V	For all $4.5 \leq V_{DD} \leq 5.5\text{V}$ otherwise
D040 D040A D041 D042 D043	V_{IH}	Input High Voltage Input pins with TTL buffer with Schmitt Trigger buffer $\overline{\text{RESET}}$, RXIR OSC1	2.0 0.25 V_{DD} + 0.8 V_{DD} 0.8 V_{DD} 0.7 V_{DD}	— — — — —	V_{DD} V_{DD} V_{DD} V_{DD} V_{DD}	V V V V V	$4.5 \leq V_{DD} \leq 5.5\text{V}$ otherwise For entire V_{DD} range
D060 D061 D063	I_{IL}	Input Leakage Current ^(1, 2) Input pins $\overline{\text{RESET}}$ OSC1	— — —	— — —	± 1 ± 30 ± 5	μA μA μA	$V_{SS} \leq V_{PIN} \leq V_{DD}$, Pin at hi-impedance $V_{SS} \leq V_{PIN} \leq V_{DD}$ $V_{SS} \leq V_{PIN} \leq V_{DD}$, XT, HS and LP osc configuration
D070	I_{pur}	weak pull-up current	50	250	400	μA	$V_{DD} = 5\text{V}$, $V_{PIN} = V_{SS}$

Note 1: The leakage current on the $\overline{\text{RESET}}$ pin is strongly dependent on the applied voltage level. The specified levels represent normal operating conditions. Higher leakage current may be measured at different input voltages.

2: Negative current is defined as coming out of the pin.

DC Characteristics (Continued)

DC CHARACTERISTICS			Standard Operating Conditions (unless otherwise specified)				
			Operating temperature $-40^{\circ}\text{C} \leq T_A \leq +85^{\circ}\text{C}$ (industrial)				
			Operating voltage V_{DD} range as described in DC spec Section 4.1 "DC Characteristics"				
Param No.	Sym	Characteristic	Min	Typ	Max	Units	Conditions
D080	VoL	Output Low Voltage TXIR, RX	—	—	0.6	V	$I_{OL} = 8.5\text{ mA}$, $V_{DD} = 4.5\text{V}$, -40°C to $+85^{\circ}\text{C}$
D083		OSC2	—	—	0.6	V	$I_{OL} = 1.6\text{ mA}$, $V_{DD} = 4.5\text{V}$, -40°C to $+85^{\circ}\text{C}$
D090	VoH	Output High Voltage TXIR, RX ⁽¹⁾	$V_{DD} - 0.7$	—	—	V	$I_{OH} = -3.0\text{ mA}$, $V_{DD} = 4.5\text{V}$, -40°C to $+85^{\circ}\text{C}$
D092		OSC2	$V_{DD} - 0.7$	—	—	V	$I_{OH} = -1.3\text{ mA}$, $V_{DD} = 4.5\text{V}$, -40°C to $+85^{\circ}\text{C}$
Capacitive Loading Specs on Output Pins							
D100	Cosc2	OSC2 pin	—	—	15	pF	when external clock is used to drive OSC1.
D101	CIO	All Input or Output pins	—	—	50	pF	

Note 1: Negative current is defined as coming out of the pin.

MCP2120

4.2 Timing Parameter Symbology and Load Conditions

The timing parameter symbols have been created following one of the following formats:

4.2.1 TIMING CONDITIONS

The temperature and voltages specified in [Table 4-2](#) apply to all timing specifications unless otherwise noted. [Figure 4-2](#) specifies the load conditions for the timing specifications.

TABLE 4-1: SYMBOLOGY

1. TppS2ppS		2. TppS	
T		T	Time
F	Frequency		
E	Error		

Lowercase letters (pp) and their meanings:

pp			
io	Input or Output pin	osc	Oscillator
rx	Receive	tx	Transmit
bitclk	RX/TX BITCLK	RST	Reset
drt	Device Reset Timer		

Uppercase letters and their meanings:

S			
F	Fall	P	Period
H	High	R	Rise
I	Invalid (Hi-impedance)	V	Valid
L	Low	Z	Hi-impedance

TABLE 4-2: AC TEMPERATURE AND VOLTAGE SPECIFICATIONS

AC CHARACTERISTICS	Standard Operating Conditions (unless otherwise stated) Operating temperature $-40^{\circ}\text{C} \leq T_A \leq +85^{\circ}\text{C}$ (industrial) Operating voltage V_{DD} range as described in DC spec Section 4.1 “DC Characteristics”.
---------------------------	---

FIGURE 4-2: Load Conditions for Device Timing Specifications

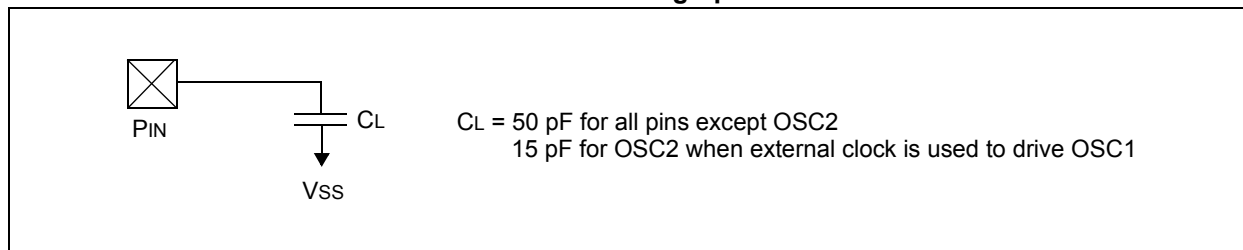

4.3 Timing Diagrams and Specifications

FIGURE 4-3: External Clock Timing

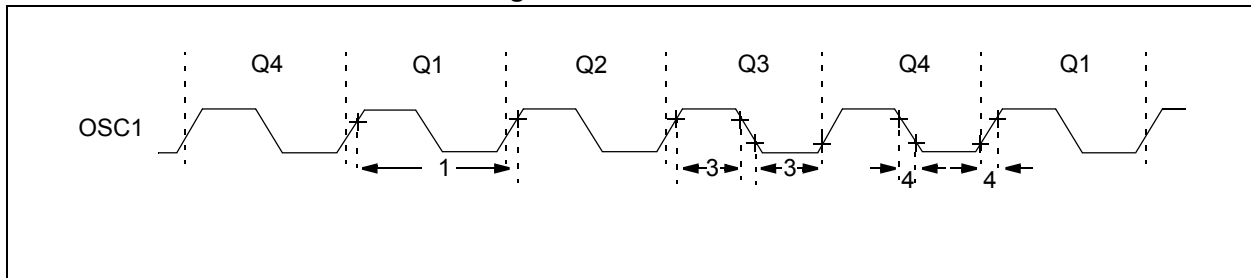

TABLE 4-3: EXTERNAL CLOCK TIMING REQUIREMENTS

AC Characteristics			Standard Operating Conditions (unless otherwise specified) Operating Temperature $-40^{\circ}\text{C} \leq T_A \leq +85^{\circ}\text{C}$ (industrial) Operating Voltage V_{DD} range is described in Section 4.1 "DC Characteristics"				
Param. No.	Sym	Characteristic	Min	Typ ⁽¹⁾	Max	Units	Conditions
1	TOSC	External CLKIN Period ^(2,3)	50	—	—	ns	
		Oscillator Period ⁽²⁾	50	—	500	ns	
1A	FOSC	External CLKIN Frequency ^(2,3)	DC	—	20	MHz	
		Oscillator Frequency ⁽²⁾	2	—	20	MHz	
1C	ECLK	Clock Error	—	—	0.01	%	
3	TosL, TosH	Clock in (OSC1) Low or High Time	10	—	—	ns	
4	TosR, TosF	Clock in (OSC1) Rise or Fall Time	—	—	15	ns	

- Note 1:** Data in the Typical ("Typ") column is at 5V, +25°C unless otherwise stated. These parameters are for design guidance only and are not tested.
- 2:** All specified values are based on characterization data for that particular oscillator type under standard operating conditions with the device executing code. Exceeding these specified limits may result in an unstable oscillator operation and/or higher than expected current consumption. When an external clock input is used, the "max" cycle time limit is "DC" (no clock) for all devices.
- 3:** A duty cycle of no more than 60/40 (High Time / Low Time or Low Time / High Time) is recommended for external clock inputs.

MCP2120

FIGURE 4-4: I/O Waveform

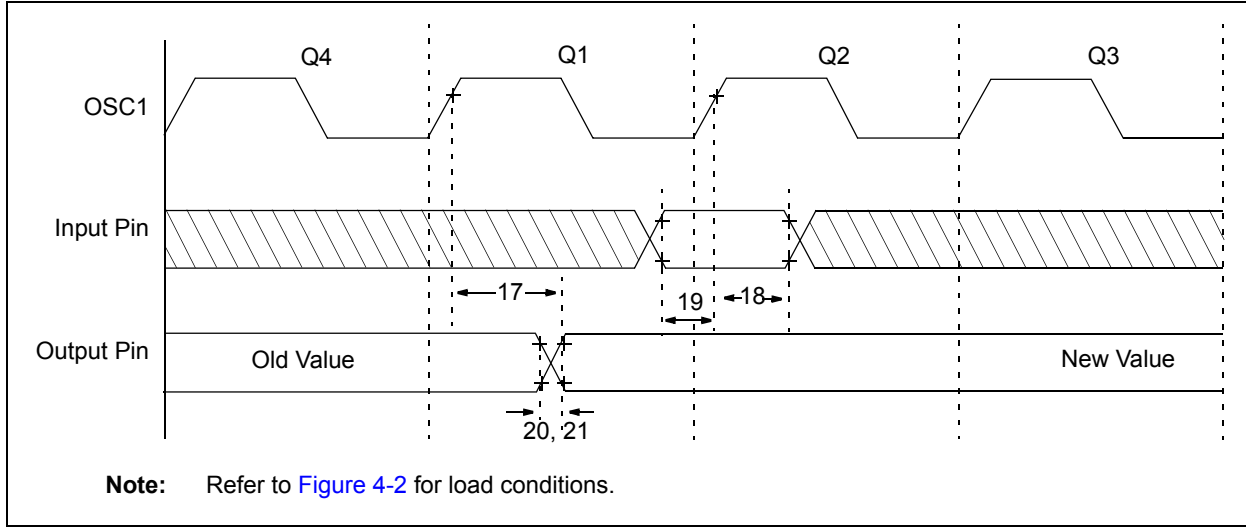

TABLE 4-4: I/O TIMING REQUIREMENTS

AC Characteristics			Standard Operating Conditions (unless otherwise specified) Operating Temperature $-40^{\circ}\text{C} \leq T_A \leq +85^{\circ}\text{C}$ (industrial) Operating Voltage V_{DD} range is described in Section 4.1 "DC Characteristics"				
Param. No.	Sym	Characteristic	Min	Typ ⁽¹⁾	Max	Units	Conditions
17	TosH2ioV	OSC1 \uparrow (Q1 cycle) to Output valid ⁽²⁾	—	—	100	ns	
18	TosH2iol	OSC1 \uparrow (Q2 cycle) to Input invalid (I/O in hold time)	200	—	—	ns	
19	TioV2osH	Input valid to OSC1 \uparrow (I/O in setup time)	0	—	—	ns	
20	ToR	RX and TXIR pin rise time ⁽²⁾	—	10	25	ns	
21	ToF	RX and TXIR pin fall time ⁽²⁾	—	10	25	ns	

Note 1: Data in the Typical ("Typ") column is at 5V, +25°C unless otherwise stated.

2: See [Figure 4-2](#) for loading conditions.

FIGURE 4-5: $\overline{\text{RESET}}$ and Device Reset Timer Timing

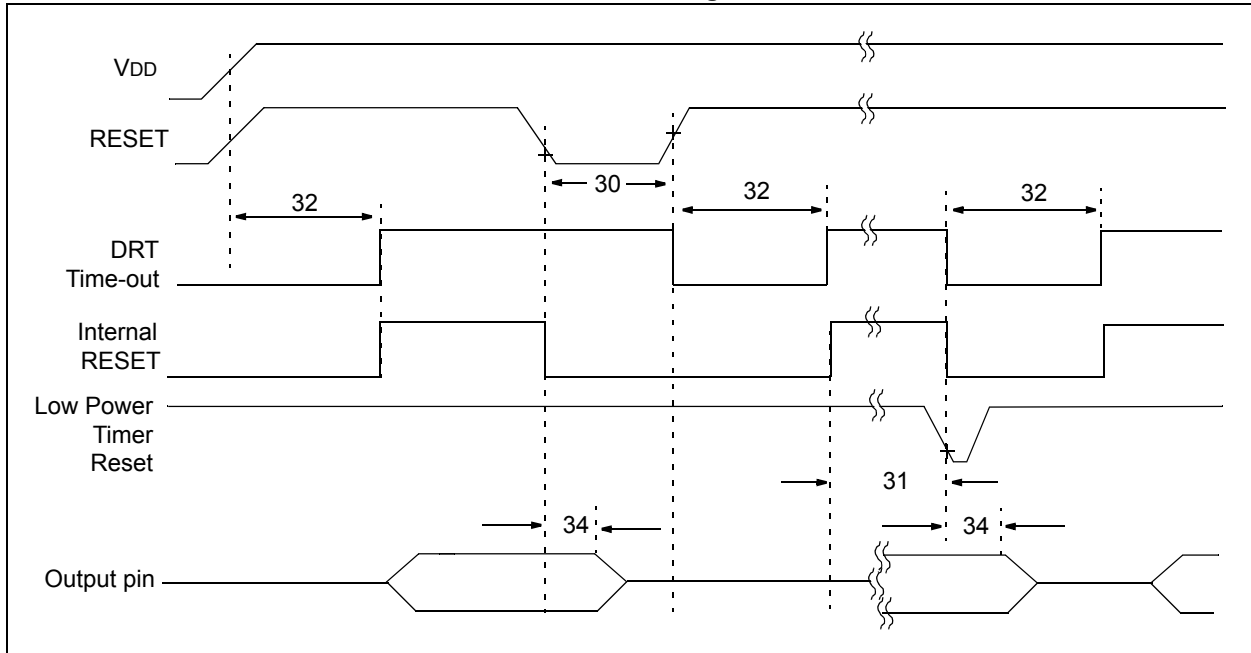

TABLE 4-5: $\overline{\text{RESET}}$ AND DEVICE RESET TIMER REQUIREMENTS

AC Characteristics		Standard Operating Conditions (unless otherwise specified) Operating Temperature $-40^{\circ}\text{C} \leq T_A \leq +85^{\circ}\text{C}$ (industrial) Operating Voltage V_{DD} range is described in Section 4.1 "DC Characteristics"					
Param. No.	Sym	Characteristic	Min	Typ ⁽¹⁾	Max	Units	Conditions
30	TRSTL	$\overline{\text{RESET}}$ Pulse Width (low)	2000	—	—	ns	$V_{DD} = 5.0\text{ V}$
31	TLPT	Low Power Time-out Period	9	18	30	ms	$V_{DD} = 5.0\text{ V}$
32	TDRT	Device Reset Timer Period	9	18	30	ms	$V_{DD} = 5.0\text{ V}$
34	TioZ	Output Hi-impedance from $\overline{\text{RESET}}$ Low or device Reset	—	—	2	μs	

Note 1: Data in the Typical ("Typ") column is at 5V, 25°C unless otherwise stated.

MCP2120

FIGURE 4-6: USART ASynchronous Transmission Waveform

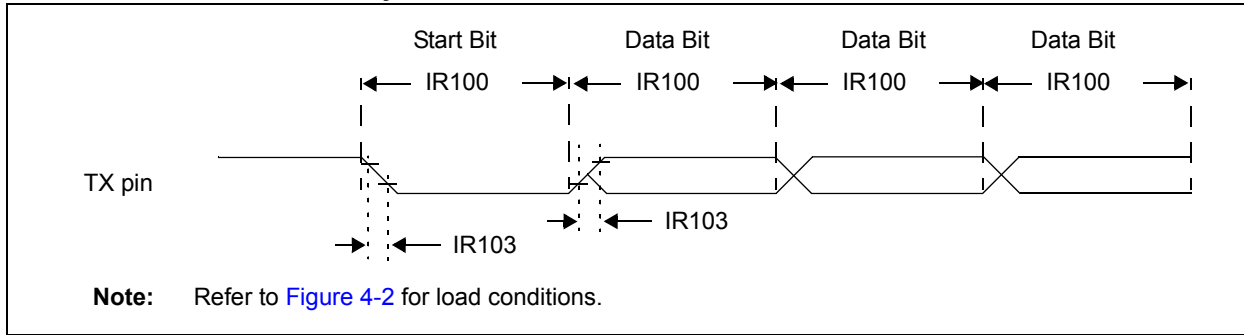

TABLE 4-6: USART ASYNCHRONOUS TRANSMISSION REQUIREMENTS

AC Characteristics			Standard Operating Conditions (unless otherwise specified) Operating Temperature $-40^{\circ}\text{C} \leq T_A \leq +85^{\circ}\text{C}$ (industrial) Operating Voltage V_{DD} range is described in Section 4.1 "DC Characteristics"				
Param. No.	Sym	Characteristic	Min	Typ	Max	Units	Conditions
IR100	TTXBIT	Transmit Baud rate	768	—	768	Tosc	Hardware Selection
							BAUD2:BAUD0 = 000
							BAUD2:BAUD0 = 001
							BAUD2:BAUD0 = 010
							BAUD2:BAUD0 = 011
							BAUD2:BAUD0 = 100
							Software Selection
							BAUD2:BAUD0 = 111
							Hex Command = 0x87
							Hex Command = 0x8B
Hex Command = 0x85							
Hex Command = 0x83							
Hex Command = 0x81							
IR101	ETXBIT	Transmit (TX pin) Baud rate Error (into MCP2120)	—	—	1	%	
IR102	ETXIRBIT	Transmit (TXIR pin) Baud rate Error (out of MCP2120) ⁽¹⁾	—	—	1	%	
IR103	TTXRF	TX pin rise time and fall time	—	—	25	ns	

Note 1: This error is not additive to IR101 parameter.

FIGURE 4-7: USART ASynchronous Receive Timing

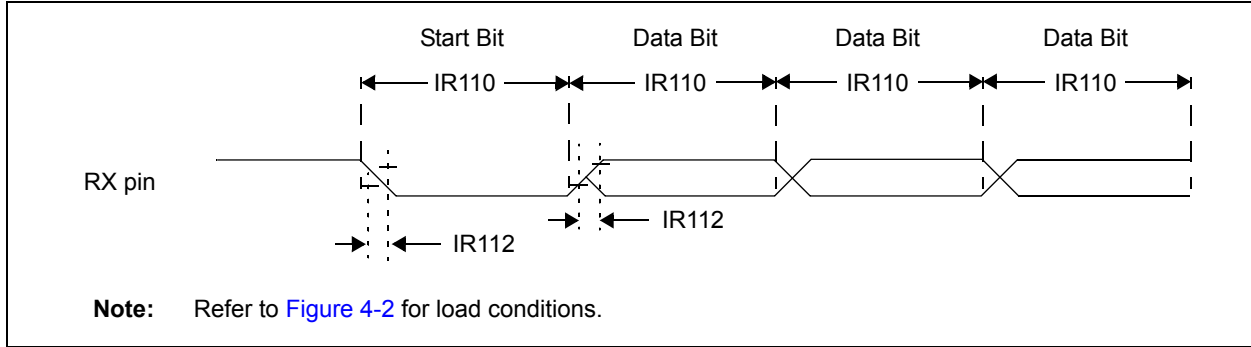

TABLE 4-7: USART ASYNCHRONOUS RECEIVE REQUIREMENTS

AC Characteristics			Standard Operating Conditions (unless otherwise specified) Operating Temperature $-40^{\circ}\text{C} \leq T_A \leq +85^{\circ}\text{C}$ (industrial) Operating Voltage V_{DD} range is described in Section 4.1 “DC Characteristics”				
Param. No.	Sym	Characteristic	Min	Typ	Max	Units	Conditions
IR110	TRXBIT	Receive Baud Rate	768	—	768	Tosc	Hardware Selection BAUD2:BAUD0 = 000
			384	—	384	Tosc	BAUD2:BAUD0 = 001
			192	—	192	Tosc	BAUD2:BAUD0 = 010
			128	—	128	Tosc	BAUD2:BAUD0 = 011
			64	—	64	Tosc	BAUD2:BAUD0 = 100
			768	—	768	Tosc	Software Selection BAUD2:BAUD0 = 111 Hex Command = 0x87
			384	—	384	Tosc	Hex Command = 0x8B
			192	—	192	Tosc	Hex Command = 0x85
			128	—	128	Tosc	Hex Command = 0x83
			64	—	64	Tosc	Hex Command = 0x81
IR111	ERXBIT	Receive (RXIR pin) Baud rate Error (into MCP2120)	—	—	1	%	
IR112	ERXBIT	Receive (RX pin) Baud rate Error (out of MCP2120) ⁽¹⁾	—	—	1	%	
IR113	TTXRF	RX pin rise time and fall time	—	—	25	ns	

Note 1: This error is not additive to IR111 parameter.

MCP2120

FIGURE 4-8: TX and TXIR Waveforms

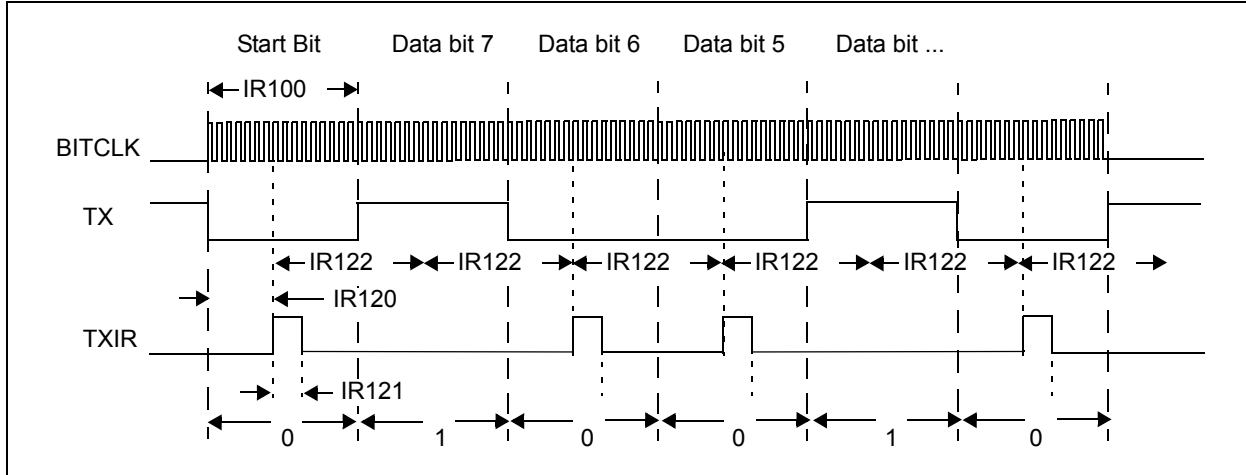

TABLE 4-8: TX AND TXIR REQUIREMENTS

AC Characteristics			Standard Operating Conditions (unless otherwise specified) Operating Temperature $-40^{\circ}\text{C} \leq T_A \leq +85^{\circ}\text{C}$ (industrial) Operating Voltage V_{DD} range is described in Section 4.1 “DC Characteristics”				
Param. No.	Sym	Characteristic	Min	Typ	Max	Units	Conditions
IR100	T _{TXBIT}	Transmit Baud Rate	768	—	768	T _{OSC}	Hardware Selection BAUD2:BAUD0 = 000
			384	—	384	T _{OSC}	BAUD2:BAUD0 = 001
			192	—	192	T _{OSC}	BAUD2:BAUD0 = 010
			128	—	128	T _{OSC}	BAUD2:BAUD0 = 011
			64	—	64	T _{OSC}	BAUD2:BAUD0 = 100
					8		Software Selection BAUD2:BAUD0 = 111
			768	—	768	T _{OSC}	Hex Command = 0x87
			384	—	384	T _{OSC}	Hex Command = 0x8B
			192	—	192	T _{OSC}	Hex Command = 0x85
			128	—	128	T _{OSC}	Hex Command = 0x83
64	—	64	T _{OSC}	Hex Command = 0x81			
IR120	T _{TXL2TXIRH}	TX falling edge (↓) to TXIR rising edge (↑) ⁽¹⁾	7T _{BITCLK} - 8.34 μs	7	7T _{BITCLK} + 8.34 μs	T _{BITCLK}	
IR121	T _{TXIRPW}	TXIR pulse width	12	—	12	T _{OSC}	
IR122	T _{TXIRP}	TXIR bit period ⁽¹⁾	—	16	—	T _{BITCLK}	

Note 1: T_{BITCLK} = T_{TXBIT}/16

FIGURE 4-9: RXIR and RX Waveforms

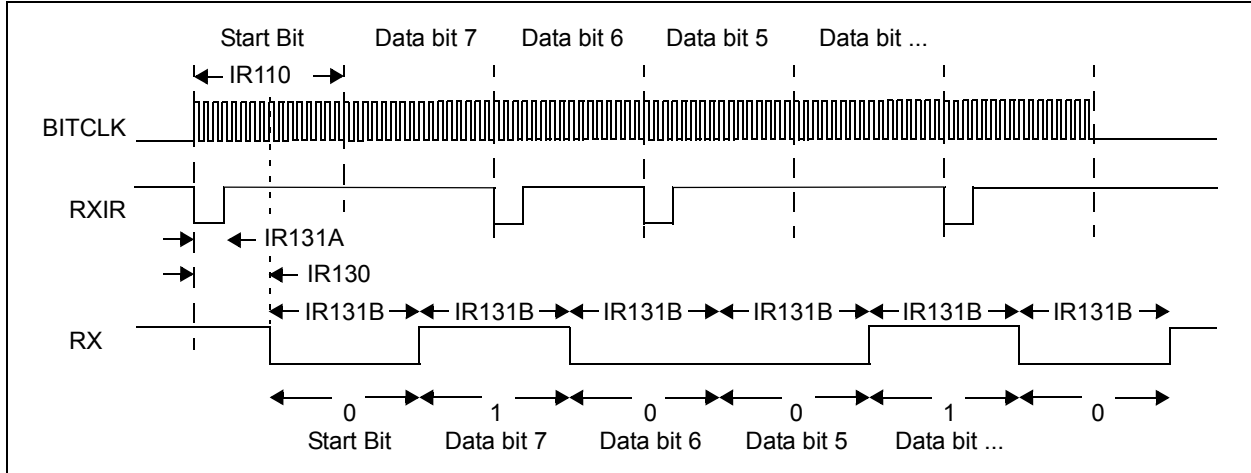

TABLE 4-9: RXIR REQUIREMENTS

AC Characteristics			Standard Operating Conditions (unless otherwise specified) Operating Temperature $-40^{\circ}\text{C} \leq T_A \leq +85^{\circ}\text{C}$ (industrial) Operating Voltage V_{DD} range is described in Section 4.1 "DC Characteristics"				
Param. No.	Sym	Characteristic	Min	Typ	Max	Units	Conditions
IR110	TRXBIT	Receive Baud Rate	768	—	768	TOSC	Hardware Selection BAUD2:BAUD0 = 000
			384	—	384	TOSC	BAUD2:BAUD0 = 001
			192	—	192	TOSC	BAUD2:BAUD0 = 010
			128	—	128	TOSC	BAUD2:BAUD0 = 011
			64	—	64	TOSC	BAUD2:BAUD0 = 100
			768	—	768	TOSC	Software Selection BAUD2:BAUD0 = 111 Hex Command = 0x87
			384	—	384	TOSC	Hex Command = 0x8B
			192	—	192	TOSC	Hex Command = 0x85
			128	—	128	TOSC	Hex Command = 0x83
			64	—	64	TOSC	Hex Command = 0x81
IR130	TRXIRL2RXH	RXIR falling edge (\downarrow) to RX falling edge (\downarrow) ⁽¹⁾	$8T_{\text{BITCLK}} - 8.34 \mu\text{s}$	8	$8T_{\text{BITCLK}} + 8.34 \mu\text{s}$	T_{BITCLK}	
IR131A	TRXIRPW	RXIR pulse width	3	—	3	TOSC	
IR132	TRXIRP	RXIR bit period ⁽¹⁾	—	16	—	T_{BITCLK}	

Note 1: $T_{\text{BITCLK}} = \text{TRXBIT}/16$

MCP2120

FIGURE 4-10: Command Mode: TX and RX Waveforms

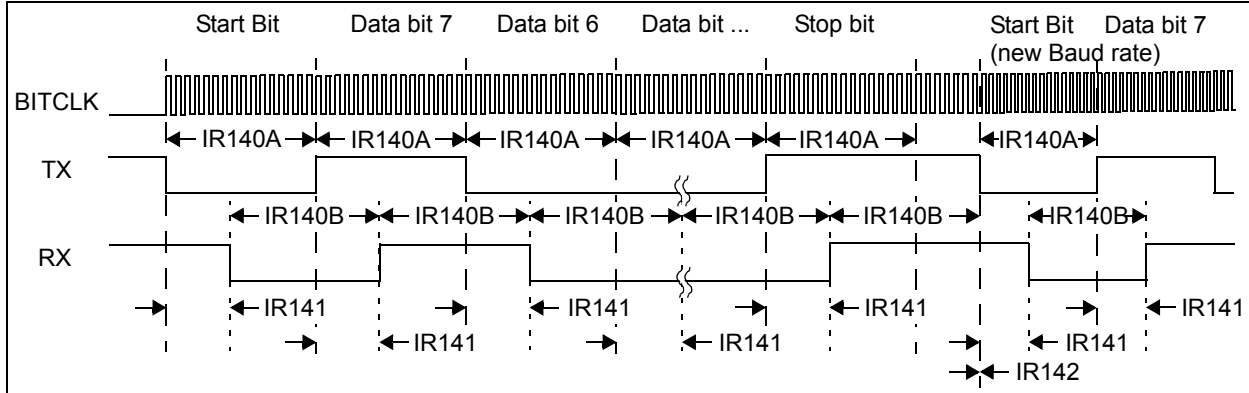

TABLE 4-10: TX AND TXIR REQUIREMENTS

AC Characteristics			Standard Operating Conditions (unless otherwise specified) Operating Temperature $-40^{\circ}\text{C} \leq T_A \leq +85^{\circ}\text{C}$ (industrial) Operating Voltage V_{DD} range is described in Section 4.1 “DC Characteristics”				
Param. No.	Sym	Characteristic	Min	Typ	Max	Units	Conditions
IR140A	BTX	Transmit Baud Rate	16	—	16	TBITCLK	
IR140B	BRX	Receive Baud Rate	16	—	16	TBITCLK	
IR141	T _{TXE2RXE}	TX edge to RX edge (delay)	5.5	8	10.5	TBITCLK	
IR142	T _{RXP2TXS}	Delay from RX Stop bit complete to TX Start bit (new baud rate)	—	—	0	TOSC	

5.0 DC AND AC CHARACTERISTICS GRAPHS AND TABLES

The graphs and tables provided in this section are for design guidance and are not tested. In some graphs or tables the data presented is outside specified operating range (e.g., outside specified VDD range). This is for information only and devices will operate properly only within the specified range.

The data presented in this section is a statistical summary of data collected on units from different lots over a period of time. "Typical" represents the mean of the distribution while "max" or "min" represents (mean + 3s) and (mean - 3s) respectively, where s is standard deviation.

FIGURE 5-1: Short DRT Period Vs. VDD

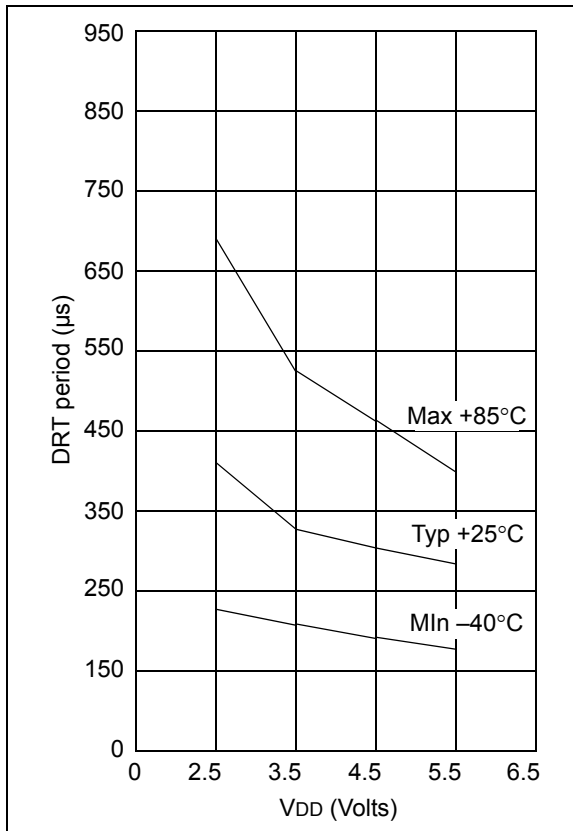

MCP2120

FIGURE 5-2: I_{OH} vs. V_{OH} , $V_{DD} = 2.5V$

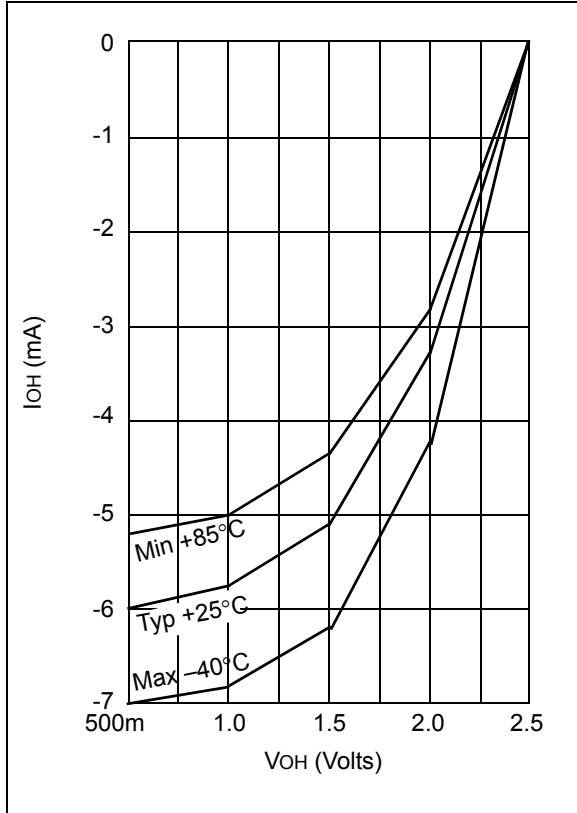

FIGURE 5-4: I_{OL} vs. V_{OL} , $V_{DD} = 2.5V$

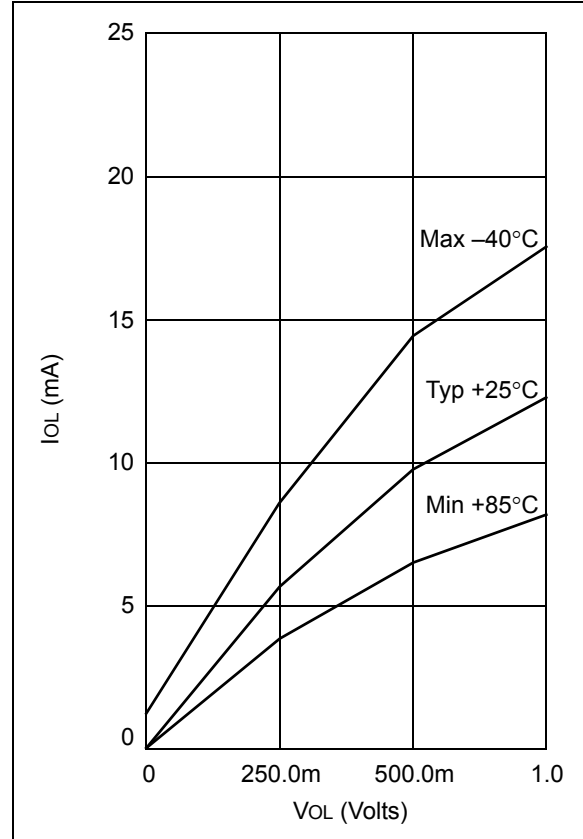

FIGURE 5-3: I_{OH} vs. V_{OH} , $V_{DD} = 5.5V$

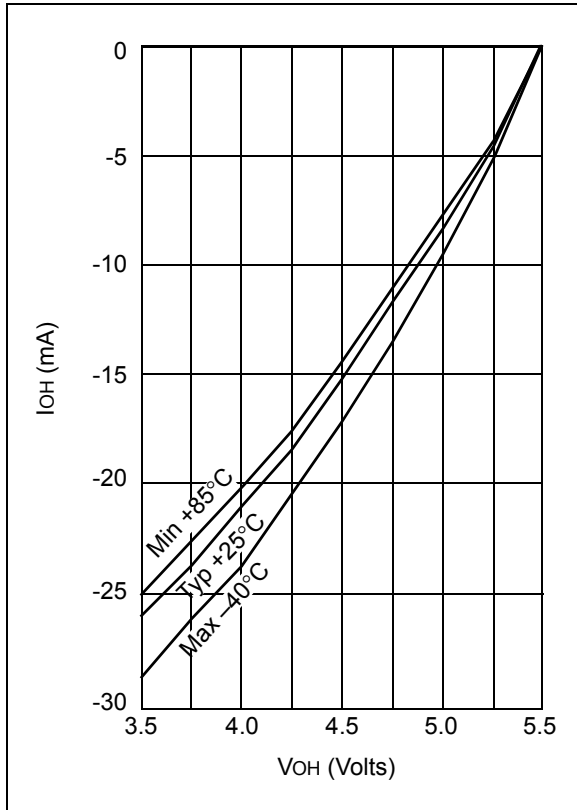
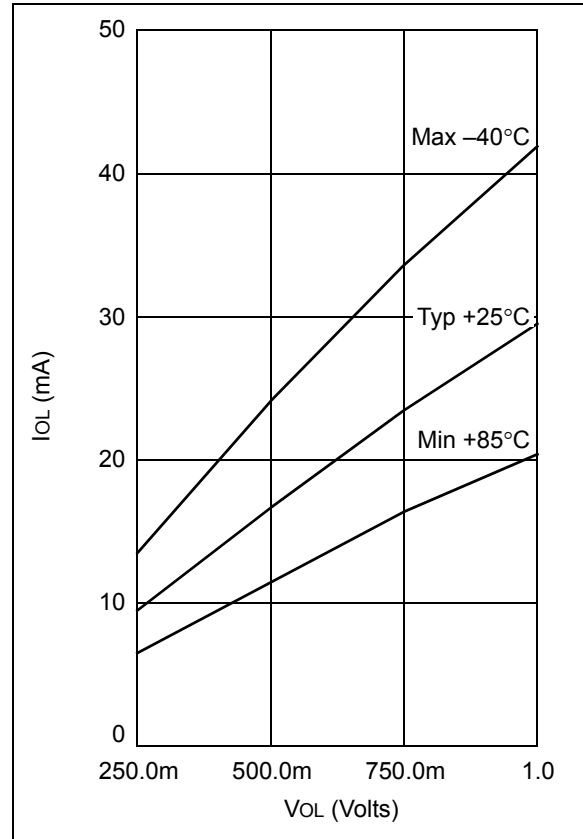

FIGURE 5-1: I_{OL} vs. V_{OL} , $V_{DD} = 5.5V$



6.0 PACKAGING INFORMATION

6.1 Package Marking Information

14-Lead PDIP (300 mil)

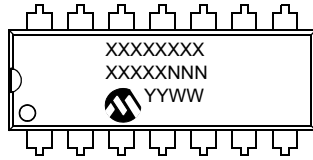

Example:

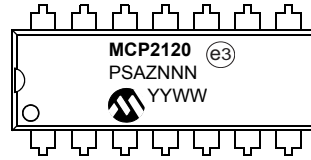

14-Lead SOIC (150 mil)

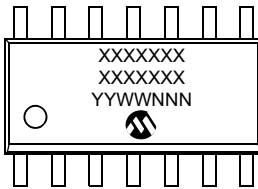

Example:

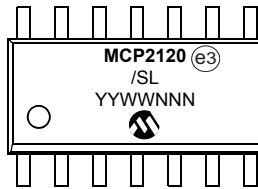

Legend:	XX...X	Customer-specific information
	Y	Year code (last digit of calendar year)
	YY	Year code (last 2 digits of calendar year)
	WW	Week code (week of January 1 is week '01')
	NNN	Alphanumeric traceability code
	(e3)	Pb-free JEDEC designator for Matte Tin (Sn)
	*	This package is Pb-free. The Pb-free JEDEC designator (e3) can be found on the outer packaging for this package.

Note: In the event the full Microchip part number cannot be marked on one line, it will be carried over to the next line, thus limiting the number of available characters for customer-specific information.

MCP2120

14-Lead Plastic Dual In-Line (P) – 300 mil Body [PDIP]

Note: For the most current package drawings, please see the Microchip Packaging Specification located at <http://www.microchip.com/packaging>

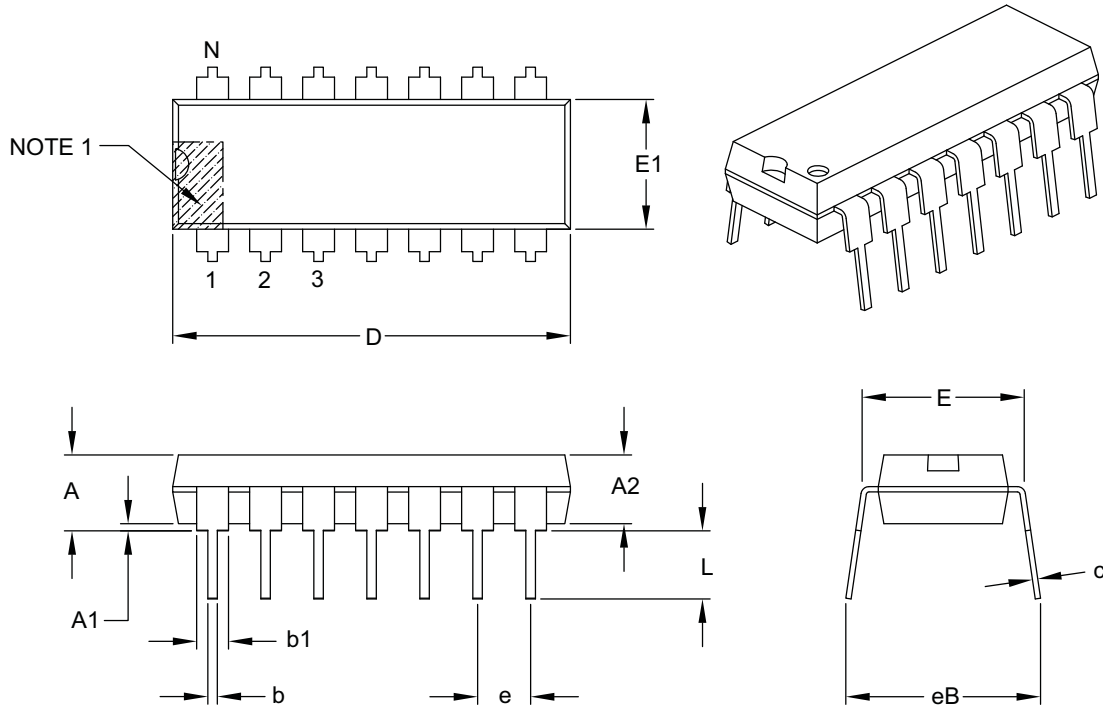

Dimension Limits	Units	INCHES		
		MIN	NOM	MAX
Number of Pins	N	14		
Pitch	e	.100 BSC		
Top to Seating Plane	A	–	–	.210
Molded Package Thickness	A2	.115	.130	.195
Base to Seating Plane	A1	.015	–	–
Shoulder to Shoulder Width	E	.290	.310	.325
Molded Package Width	E1	.240	.250	.280
Overall Length	D	.735	.750	.775
Tip to Seating Plane	L	.115	.130	.150
Lead Thickness	c	.008	.010	.015
Upper Lead Width	b1	.045	.060	.070
Lower Lead Width	b	.014	.018	.022
Overall Row Spacing §	eB	–	–	.430

Notes:

- Pin 1 visual index feature may vary, but must be located with the hatched area.
- § Significant Characteristic.
- Dimensions D and E1 do not include mold flash or protrusions. Mold flash or protrusions shall not exceed .010" per side.
- Dimensioning and tolerancing per ASME Y14.5M.

BSC: Basic Dimension. Theoretically exact value shown without tolerances.

Microchip Technology Drawing C04-005B

14-Lead Plastic Small Outline (SL) – Narrow, 3.90 mm Body [SOIC]

Note: For the most current package drawings, please see the Microchip Packaging Specification located at <http://www.microchip.com/packaging>

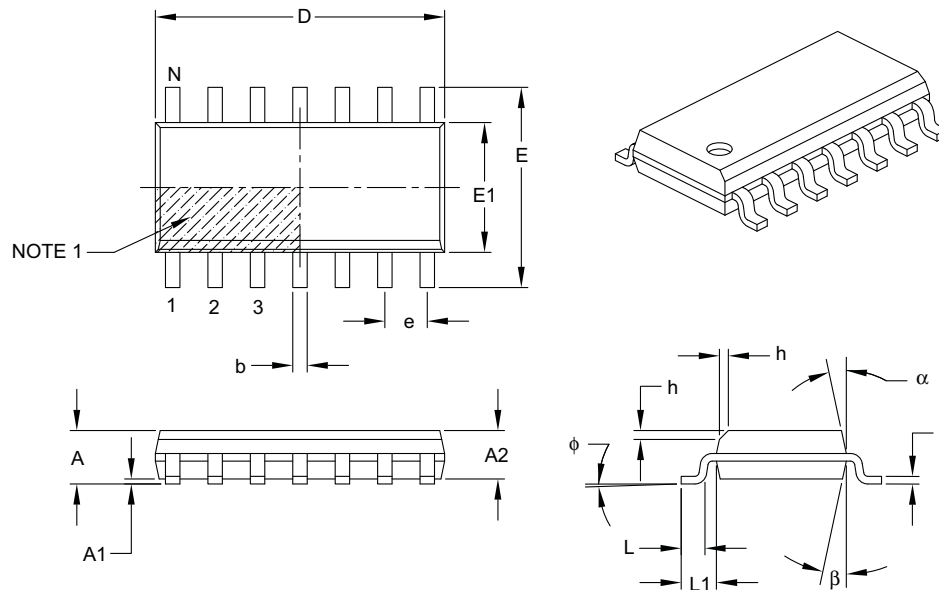

Units		MILLMETERS		
Dimension Limits		MIN	NOM	MAX
Number of Pins	N	14		
Pitch	e	1.27 BSC		
Overall Height	A	–	–	1.75
Molded Package Thickness	A2	1.25	–	–
Standoff §	A1	0.10	–	0.25
Overall Width	E	6.00 BSC		
Molded Package Width	E1	3.90 BSC		
Overall Length	D	8.65 BSC		
Chamfer (optional)	h	0.25	–	0.50
Foot Length	L	0.40	–	1.27
Footprint	L1	1.04 REF		
Foot Angle	ϕ	0°	–	8°
Lead Thickness	c	0.17	–	0.25
Lead Width	b	0.31	–	0.51
Mold Draft Angle Top	α	5°	–	15°
Mold Draft Angle Bottom	β	5°	–	15°

Notes:

- Pin 1 visual index feature may vary, but must be located within the hatched area.
- § Significant Characteristic.
- Dimensions D and E1 do not include mold flash or protrusions. Mold flash or protrusions shall not exceed 0.15 mm per side.
- Dimensioning and tolerancing per ASME Y14.5M.

BSC: Basic Dimension. Theoretically exact value shown without tolerances.

REF: Reference Dimension, usually without tolerance, for information purposes only.

Microchip Technology Drawing C04-065B

MCP2120

FIGURE 6-1: EMBOSSED CARRIER DIMENSIONS (16 MM TAPE)

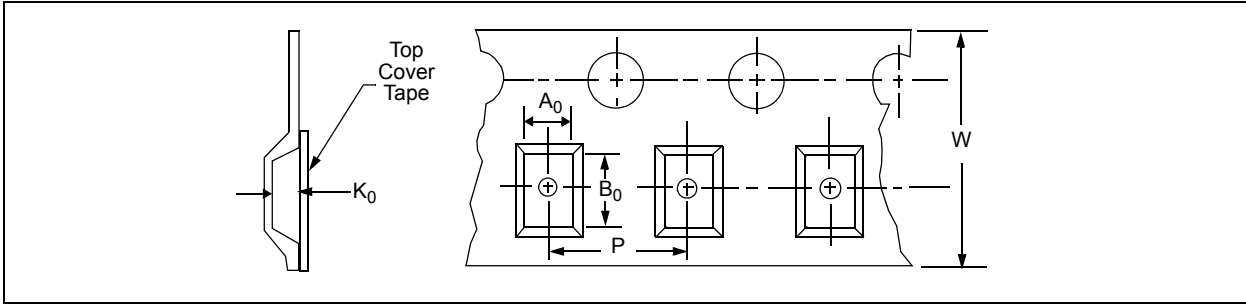
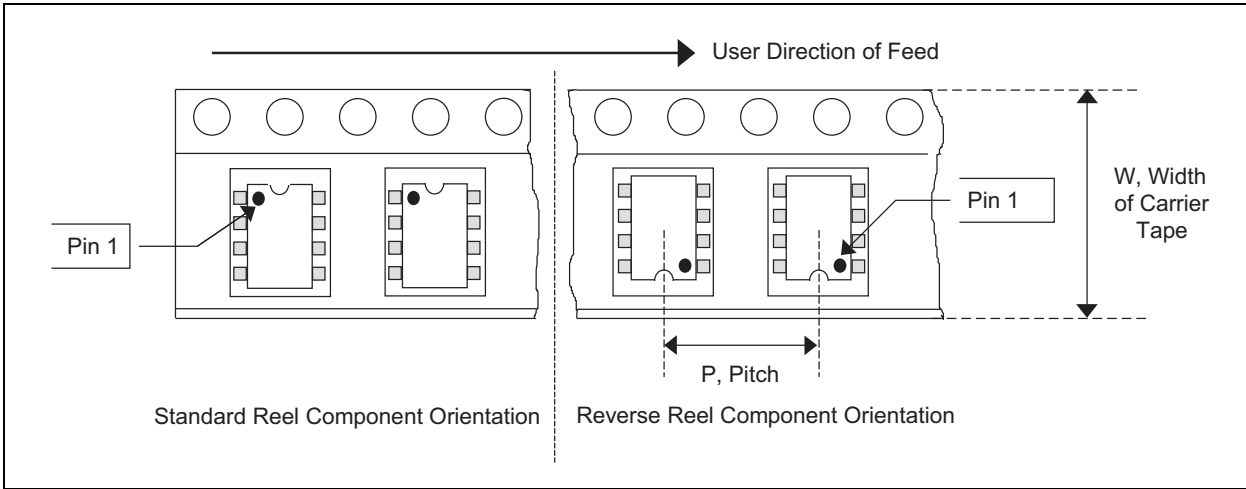

TABLE 6-1: CARRIER TAPE/CAVITY DIMENSIONS

Case Outline	Package Type	Carrier Dimensions		Cavity Dimensions			Output Quantity Units	Reel Diameter in mm
		W mm	P mm	A0 mm	B0 mm	K0 mm		
SL	SOIC .150" 14L	16	8	6.5	9.5	2.1	2600	330

FIGURE 6-2: SOIC DEVICE



APPENDIX A: REVISION HISTORY

Revision B (February 2007)

- Updated Development Tools section
- Update packaging outline drawings
- Updates Product Identification System section.

Revision A (March 2001)

- Initial release of this document

NOTES:

PRODUCT IDENTIFICATION SYSTEM

To order or obtain information, e.g., on pricing or delivery, refer to the factory or the listed sales office.

<u>PART NO.</u>	<u>X</u>	<u>XX</u>
Device	Temperature Range	Package
Device	MCP2120: Infrared Encoder/Decoder MCP2120T: Infrared Encoder/Decoder, Tape and Reel	
Temperature Range	I = -40°C to +85°C	
Package	P = Plastic DIP (300 mil, Body), 14-lead SL = Plastic SOIC (150 mil, Body), 14-lead	

Examples:

- a) MCP2120-I/P: Industrial Temperature, PDIP packaging
- b) MCP2120-I/SL: Industrial Temperature, SOIC package
- c) MCP2120T-I/SL: Tape and Reel, Industrial Temperature, SOIC package

MCP2120

NOTES:

Note the following details of the code protection feature on Microchip devices:

- Microchip products meet the specification contained in their particular Microchip Data Sheet.
- Microchip believes that its family of products is one of the most secure families of its kind on the market today, when used in the intended manner and under normal conditions.
- There are dishonest and possibly illegal methods used to breach the code protection feature. All of these methods, to our knowledge, require using the Microchip products in a manner outside the operating specifications contained in Microchip's Data Sheets. Most likely, the person doing so is engaged in theft of intellectual property.
- Microchip is willing to work with the customer who is concerned about the integrity of their code.
- Neither Microchip nor any other semiconductor manufacturer can guarantee the security of their code. Code protection does not mean that we are guaranteeing the product as “unbreakable.”

Code protection is constantly evolving. We at Microchip are committed to continuously improving the code protection features of our products. Attempts to break Microchip's code protection feature may be a violation of the Digital Millennium Copyright Act. If such acts allow unauthorized access to your software or other copyrighted work, you may have a right to sue for relief under that Act.

Information contained in this publication regarding device applications and the like is provided only for your convenience and may be superseded by updates. It is your responsibility to ensure that your application meets with your specifications. MICROCHIP MAKES NO REPRESENTATIONS OR WARRANTIES OF ANY KIND WHETHER EXPRESS OR IMPLIED, WRITTEN OR ORAL, STATUTORY OR OTHERWISE, RELATED TO THE INFORMATION, INCLUDING BUT NOT LIMITED TO ITS CONDITION, QUALITY, PERFORMANCE, MERCHANTABILITY OR FITNESS FOR PURPOSE. Microchip disclaims all liability arising from this information and its use. Use of Microchip devices in life support and/or safety applications is entirely at the buyer's risk, and the buyer agrees to defend, indemnify and hold harmless Microchip from any and all damages, claims, suits, or expenses resulting from such use. No licenses are conveyed, implicitly or otherwise, under any Microchip intellectual property rights.

Trademarks

The Microchip name and logo, the Microchip logo, Accuron, dsPIC, KEELOQ, KEELOQ logo, microID, MPLAB, PIC, PICmicro, PICSTART, PRO MATE, PowerSmart, rPIC, and SmartShunt are registered trademarks of Microchip Technology Incorporated in the U.S.A. and other countries.

AmpLab, FilterLab, Linear Active Thermistor, Migratable Memory, MXDEV, MXLAB, PS logo, SEEVAL, SmartSensor and The Embedded Control Solutions Company are registered trademarks of Microchip Technology Incorporated in the U.S.A.

Analog-for-the-Digital Age, Application Maestro, CodeGuard, dsPICDEM, dsPICDEM.net, dsPICworks, ECAN, ECONOMONITOR, FanSense, FlexROM, fuzzyLAB, In-Circuit Serial Programming, ICSP, ICEPIC, Mindi, MiWi, MPASM, MPLAB Certified logo, MPLIB, MPLINK, PICkit, PICDEM, PICDEM.net, PICLAB, PICtail, PowerCal, PowerInfo, PowerMate, PowerTool, REAL ICE, rLAB, rfPICDEM, Select Mode, Smart Serial, SmartTel, Total Endurance, UNI/O, WiperLock and ZENA are trademarks of Microchip Technology Incorporated in the U.S.A. and other countries.

SQTP is a service mark of Microchip Technology Incorporated in the U.S.A.

All other trademarks mentioned herein are property of their respective companies.

© 2007, Microchip Technology Incorporated, Printed in the U.S.A., All Rights Reserved.

 Printed on recycled paper.

QUALITY MANAGEMENT SYSTEM
CERTIFIED BY DNV
== ISO/TS 16949:2002 ==

Microchip received ISO/TS-16949:2002 certification for its worldwide headquarters, design and wafer fabrication facilities in Chandler and Tempe, Arizona, Gresham, Oregon and Mountain View, California. The Company's quality system processes and procedures are for its PIC[®] MCUs and dsPIC[®] DSCs, KEELOQ[®] code hopping devices, Serial EEPROMs, microperipherals, nonvolatile memory and analog products. In addition, Microchip's quality system for the design and manufacture of development systems is ISO 9001:2000 certified.



WORLDWIDE SALES AND SERVICE

AMERICAS

Corporate Office
2355 West Chandler Blvd.
Chandler, AZ 85224-6199
Tel: 480-792-7200
Fax: 480-792-7277
Technical Support:
<http://support.microchip.com>
Web Address:
www.microchip.com

Atlanta
Duluth, GA
Tel: 678-957-9614
Fax: 678-957-1455

Boston
Westborough, MA
Tel: 774-760-0087
Fax: 774-760-0088

Chicago
Itasca, IL
Tel: 630-285-0071
Fax: 630-285-0075

Dallas
Addison, TX
Tel: 972-818-7423
Fax: 972-818-2924

Detroit
Farmington Hills, MI
Tel: 248-538-2250
Fax: 248-538-2260

Kokomo
Kokomo, IN
Tel: 765-864-8360
Fax: 765-864-8387

Los Angeles
Mission Viejo, CA
Tel: 949-462-9523
Fax: 949-462-9608

Santa Clara
Santa Clara, CA
Tel: 408-961-6444
Fax: 408-961-6445

Toronto
Mississauga, Ontario,
Canada
Tel: 905-673-0699
Fax: 905-673-6509

ASIA/PACIFIC

Asia Pacific Office
Suites 3707-14, 37th Floor
Tower 6, The Gateway
Harbour City, Kowloon
Hong Kong
Tel: 852-2401-1200
Fax: 852-2401-3431

Australia - Sydney
Tel: 61-2-9868-6733
Fax: 61-2-9868-6755

China - Beijing
Tel: 86-10-8528-2100
Fax: 86-10-8528-2104

China - Chengdu
Tel: 86-28-8665-5511
Fax: 86-28-8665-7889

China - Fuzhou
Tel: 86-591-8750-3506
Fax: 86-591-8750-3521

China - Hong Kong SAR
Tel: 852-2401-1200
Fax: 852-2401-3431

China - Qingdao
Tel: 86-532-8502-7355
Fax: 86-532-8502-7205

China - Shanghai
Tel: 86-21-5407-5533
Fax: 86-21-5407-5066

China - Shenyang
Tel: 86-24-2334-2829
Fax: 86-24-2334-2393

China - Shenzhen
Tel: 86-755-8203-2660
Fax: 86-755-8203-1760

China - Shunde
Tel: 86-757-2839-5507
Fax: 86-757-2839-5571

China - Wuhan
Tel: 86-27-5980-5300
Fax: 86-27-5980-5118

China - Xian
Tel: 86-29-8833-7250
Fax: 86-29-8833-7256

ASIA/PACIFIC

India - Bangalore
Tel: 91-80-4182-8400
Fax: 91-80-4182-8422

India - New Delhi
Tel: 91-11-4160-8631
Fax: 91-11-4160-8632

India - Pune
Tel: 91-20-2566-1512
Fax: 91-20-2566-1513

Japan - Yokohama
Tel: 81-45-471- 6166
Fax: 81-45-471-6122

Korea - Gumi
Tel: 82-54-473-4301
Fax: 82-54-473-4302

Korea - Seoul
Tel: 82-2-554-7200
Fax: 82-2-558-5932 or
82-2-558-5934

Malaysia - Penang
Tel: 60-4-646-8870
Fax: 60-4-646-5086

Philippines - Manila
Tel: 63-2-634-9065
Fax: 63-2-634-9069

Singapore
Tel: 65-6334-8870
Fax: 65-6334-8850

Taiwan - Hsin Chu
Tel: 886-3-572-9526
Fax: 886-3-572-6459

Taiwan - Kaohsiung
Tel: 886-7-536-4818
Fax: 886-7-536-4803

Taiwan - Taipei
Tel: 886-2-2500-6610
Fax: 886-2-2508-0102

Thailand - Bangkok
Tel: 66-2-694-1351
Fax: 66-2-694-1350

EUROPE

Austria - Wels
Tel: 43-7242-2244-39
Fax: 43-7242-2244-393

Denmark - Copenhagen
Tel: 45-4450-2828
Fax: 45-4485-2829

France - Paris
Tel: 33-1-69-53-63-20
Fax: 33-1-69-30-90-79

Germany - Munich
Tel: 49-89-627-144-0
Fax: 49-89-627-144-44

Italy - Milan
Tel: 39-0331-742611
Fax: 39-0331-466781

Netherlands - Drunen
Tel: 31-416-690399
Fax: 31-416-690340

Spain - Madrid
Tel: 34-91-708-08-90
Fax: 34-91-708-08-91

UK - Wokingham
Tel: 44-118-921-5869
Fax: 44-118-921-5820

12/08/06

Looking for pricing, stock, or lifecycle information?

Click below to explore more details on WIN SOURCE:

- ⊖ [View MCP2120-I/P on WIN SOURCE](#)
- ⊖ [Microchip Technology Information](#)

Optimize Your Supply Chain with WIN SOURCE Solutions

- ✓ Global Sourcing Solution
- ✓ Obsolete Management
- ✓ Cost Control Management
- ✓ Shortage Management
- ✓ Alternative Solution
- ✓ Excess Inventory Management