



THE DATASHEET OF MCIMX27LVOP4AR2





i.MX27 and i.MX27L

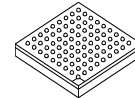

Package Information

Plastic Package
Case 1816-01
(MAPBGA-404)
Case 1931-04
(MAPBGA-473)

i.MX27 and i.MX27L Data Sheet

Multimedia Applications Processor

Ordering Information

See [Table 1](#) on [page 4](#) for ordering information.

1 Introduction

The i.MX27 and i.MX27L (MCIMX27/MX27L) multimedia applications processors represents the next step in low-power, high-performance application processors. Unless otherwise specified, the material in this data sheet is applicable to both the i.MX27 and i.MX27L processors and referred to singularly throughout this document as i.MX27.

The i.MX27L does not include the following features: ATA-6 HDD Interface, Memory Stick Pro, VPU: MPEG-4/ H.263/H.264 HW encoder/decoder, and eMMA (PrP processing, CSC, deblock, dering).

Based on an ARM926EJ-S™ microprocessor core, the i.MX27/27L processor provides the performance with low power consumption required by modern digital devices such as the following:

- Feature-rich cellular phones
- Portable media players and mobile gaming machines
- Personal digital assistants (PDAs) and wireless PDAs

Contents

1	Introduction	1
1.1	Features	2
1.2	Block Diagram	3
1.3	Ordering Information	4
2	Functional Description and Application Information	4
2.1	ARM926 Microprocessor Core Platform	4
2.2	Module Inventory	5
2.3	Module Descriptions	9
3	Signal Descriptions	26
3.1	Power-Up Sequence	35
3.2	EMI Pins Multiplexing	35
4	Electrical Characteristics	40
4.1	i.MX27/i.MX27L Chip-Level Conditions	40
4.2	Module-Level Electrical Specifications	43
4.3	Timing Diagrams	53
5	Package Information and Pinout	108
5.1	Package Outline Drawing (17 mm × 17 mm-404 pin)	108
5.2	Pin Assignments (17 mm × 17 mm-404 pin)	112
5.3	Package Outline Drawing (19 mm × 19 mm-473 pin)	131
5.4	Pin Assignments (19 mm × 19 mm-473 pin)	132
7	Revision History	153



Introduction

- Portable DVD players
- Digital cameras

The i.MX27/MX27L processor features the advanced and power-efficient ARM926EJ-S core operating at speeds up to 400 MHz, and is optimized for minimal power consumption using the most advanced techniques for power saving (for example, DPTC, power gating, and clock gating). With 90 nm technology and dual V_t , the i.MX27/MX27L device provides the optimal performance vs. leakage current balance.

The performance of the i.MX27/MX27L processors are both boosted by an on-chip cache system, and features peripheral devices, such as an MPEG-4, H.263, an H.264 video codec (up to D1—720 x 486—@ 30 FPS), LCD, eMMA_{It}, and CMOS Sensor Interface controllers.

The i.MX27/MX27L processors supports connections to various types of external memories, such as 266-MHz DDR, NAND Flash, NOR Flash, SDRAM, and SRAM. The i.MX27/MX27L devices can be connected to a variety of external devices using technology, such as high-speed USBOTG 2.0, the Advanced Technology Attachment (ATA), Multimedia/Secure Data (MMC/SDIO), and CompactFlash.

NOTE

The i.MX27L does not support the ATA-6 HDD interface.

1.1 Features

The i.MX27/MX27L processors are targeted for video and voice over-IP (V2IP) and smart remote controllers. It also provides low-power solutions for any high-performance and demanding multimedia and graphics applications.

The systems include the following features:

- Multi-standard video codec (i.MX27 only)
 - MPEG-4 part-II simple profile encoding/decoding
 - H.264/AVC baseline profile encoding/decoding
 - H.263 P3 encoding/decoding
 - Multi-party call: one stream encoding and two streams decoding simultaneously
 - Multi-format: encodes MPEG-4 bitstream, and decodes H.264 bitstream simultaneously
 - On-the-fly video processing that reduces system memory load (for example, the power-efficient viewfinder application with no involvement of either the memory system or the Arm CPU)
- Advanced power management (i.MX27/27L)
 - Dynamic process and temperature compensation
 - Multiple clock and power domains
 - Independent gating of power domains
- Multiple communication and expansion ports

1.2 Block Diagram

Figure 1 shows the i.MX27 simplified interface block diagram.

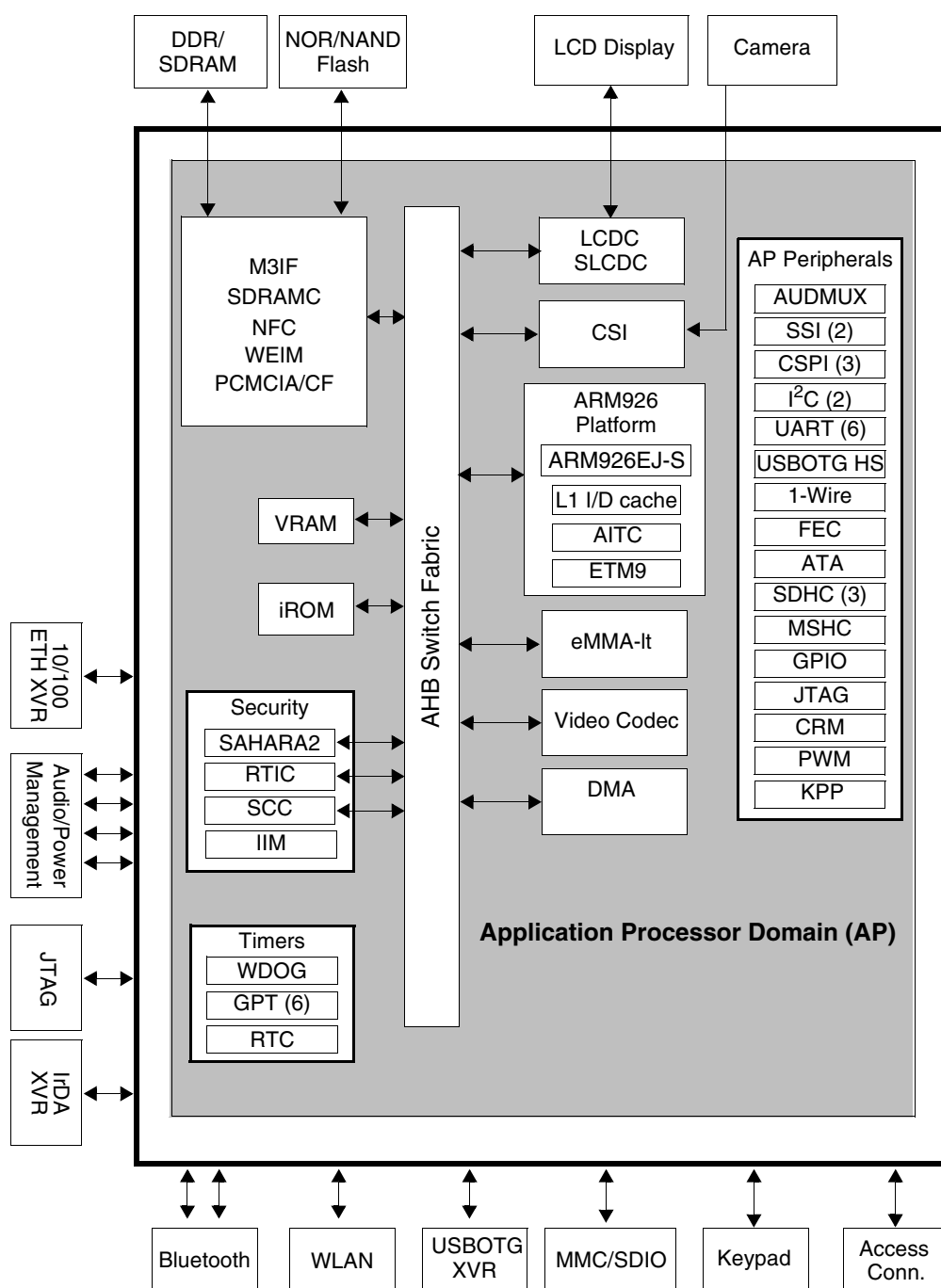

Note: The i.MX27L does not support the following:

- ATA-6 HDD Interface
- Memory Stick Pro
- VPU: MPEG-4/.263/H.264 HW encoder/decoder
- eMMA (PrP processing, CSC, deblock, dering)

Figure 1. i.MX27/MX27L Simplified Interface Block Diagram

1.3 Ordering Information

Table 1 provides ordering information for the MAPBGA, lead-free packages.

Table 1. Ordering Information

Device	Temperature	Package
MCIMX27VOP4A	-20° C to +85° C	1816-01
MCIMX27LVOP4A	-20° C to +85° C	1816-01
MCIMX27MOP4A	-40° C to +85° C	1931-04
MCIMX27LMOP4A	-40° C to +85° C	1931-04
MCIMX27VJP4A	-20° C to +85° C	1816-01
MCIMX27LVJP4A	-20° C to +85° C	1816-01
MCIMX27MJP4A	-40° C to +85° C	1931-04
MCIMX27LMJP4A	-40° C to +85° C	1931-04

2 Functional Description and Application Information

2.1 ARM926 Microprocessor Core Platform

The ARM926 Platform consists of the ARM926EJ-S processor, ETM9, ETB9, a 6 × 3 Multi-Layer AHB crossbar switch (MAX), and a “primary AHB” complex.

- The instruction bus (I-AHB) of the ARM926EJ-S processor is connected directly to MAX Master Port 0.
- The data bus (D-AHB) of the ARM926EJ-S processor is connected directly to MAX Master Port 1.

Four alternate bus master interfaces are connected to MAX Master Ports 2–5. Three slave ports of the MAX are AHB-Lite compliant buses. Slave Port 0 is designated as the “primary” AHB. The primary AHB is internal to the platform and has five slaves connected to it: the AITC interrupt module, the MCTL memory controller, and two APIP peripheral interface gaskets. Slave Ports 1 and 2 of the MAX are referred to as “secondary” AHBs. Each of the secondary AHB interfaces is only accessible off platform.

The ARM926EJ-S processor supports the 32-bit and 16-bit Arm Thumb instruction sets, enabling the user to trade off between high performance and high-code density. The ARM926EJ-S processor includes features for efficient execution of Java byte codes, providing Java performance similar to the just-in-time (JIT) compiler—which is a type of Java compiler—but without the associated code overhead.

The ARM926EJ-S processor supports the Arm debug architecture and includes logic to assist in both hardware and software debugging. The ARM926EJ-S processor has a Harvard cached architecture and provides a complete high-performance processor subsystem, including the following:

- An ARM9EJ-S integer core
- A Memory Management Unit (MMU)
- Separate instruction and data AMBA AHB bus interfaces
- ETM and JTAG-based debug support

The ARM926EJ-S processor provides support for external coprocessors enabling floating-point or other application-specific hardware acceleration to be added. The ARM926EJ-S processor implements Arm architecture version 5TEJ.

The four alternate bus master ports on the ARM926 Platform, which are connected directly to master ports of the MAX, are designed to support connections to multiple AHB masters external to the platform. An external arbitration AHB control module is needed if multiple external masters are desired to share an ARM926 Platform alternate bus master port. However, the alternate bus master ports on the platform support seamless connection to a single master with no external interface logic required.

A primary AHB MUX (PAHBMUX) module performs address decoding, read data muxing, bus watchdog, and other miscellaneous functions for the primary AHB within the platform. A clock control module (CLKCTL) is provided to support a power-conscious design methodology, as well as implementation of several clock synchronization circuits.

2.1.1 Memory System

The ARM926EJ-S complex includes 16-Kbyte Instruction and 16-Kbyte Data caches. The embedded 45-Kbyte SRAM (VRAM) can be used to avoid external memory accesses or it can be used for applications. There is also a 24-Kbyte ROM for bootstrap code.

2.2 Module Inventory

Table 2 shows an alphabetical listing of the modules in the i.MX27/MX27L multimedia applications processors. A cross-reference to each module's section and page number goes directly to a more detailed module description for additional information.

Table 2. Digital and Analog Modules

Block Mnemonic	Block Name	Functional Grouping	Brief Description	Section/Page
1-Wire®	1-Wire Interface	Connectivity Peripheral	The 1-Wire module provides bi-directional communication between the ARM926EJ-S and the Add-Only-Memory EPROM (DS2502). The 1-Kbit EPROM is used to hold information about battery and communicates with the ARM926 Platform using the IP interface.	2.3.1/9
AIPI	AHB-Lite IP Interface Module	Bus Control	The AIPI acts as an interface between the Arm Advanced High-performance Bus Lite. (AHB-Lite) and lower bandwidth peripherals that conforms to the IP Bus specification, Rev 2.0.	2.3.2/9
AITC	ARM9EJ-S Interrupt Controller	Bus Control	AITC is connected to the primary AHB as a slave device. It generates the normal and fast interrupts to the ARM926EJ-S processor.	2.3.3/10
ARM926EJS	ARM926EJ-S	CPU	The ARM926EJ-S (ARM926) is a member of the Arm9 family of general-purpose microprocessors targeted at multi-tasking applications.	2.3.4/10
ATA	Advanced Technology(AT) Attachment	Connectivity Peripheral	The ATA block is an AT attachment host interface. It interfaces with IDE hard disc drives and ATAPI optical disc drives.	2.3.5/10

Table 2. Digital and Analog Modules (continued)

Block Mnemonic	Block Name	Functional Grouping	Brief Description	Section/ Page
AUDMUX	Digital Audio Multiplexer	Multimedia Peripheral	The AUDMUX interconnections allow multiple, simultaneous audio/voice/data flows between the ports in point-to-point or point-to-multipoint configurations.	2.3.6/11
CRM	Clock and Reset Module	Clock and Reset Control	The CRM generates clock and reset signals used throughout the i.MX27/MX27L processors and also for external peripherals.	2.3.7/12
CSI	CMOS Sensor Interface	Multimedia Interface	The CSI is a logic interface which enables the i.MX27/MX27L processors to connect directly to external CMOS sensors and a CCIR656 video source.	2.3.8/12
CSPI	Configurable Serial Peripheral Interface (x3)	Connectivity Peripheral	The i.MX27/MX27L processors have three CSPI modules. CSPI is equipped with two data FIFOs and is a master/slave configurable serial peripheral interface module, allowing the i.MX27/MX27L processors to interface with both external SPI master and slave devices.	2.3.9/12
DMAC	Direct Memory Access Controller	Standard System Resource	The DMAC of the i.MX27/MX27L processors provides 16 channels supporting linear memory, 2D memory, FIFO and end-of-burst enable FIFO transfers to support a wide variety of DMA operations.	2.3.10/13
eMMA_It	eMMA_It	H/W Accelerator Functions	eMMA_It consists of a PreProcessor and PostProcessor, and provides video acceleration. The PrP and PP can be used for generic video pre and post processing such as scaling, resizing, and color space conversions.	2.3.11/13
EMI	External Memory Interface	Memory Interface (EMI)	The EMI includes <ul style="list-style-type: none"> • Multi-Master Memory Interface (M3IF) • Enhanced SDRAM/MDDR memory controller (ESDRAMC) • PCMCIA memory controller (PCMCIA) • NAND Flash Controller (NFC) • Wireless External Interface Module (WEIM) 	—
ESDRAMC	Enhanced SDRAM Controller	External Memory Interface	The ESDRAMC provides interface and control for synchronous DRAM memories for the system.	2.3.12/15
FEC	Fast Ethernet Controller	Connectivity Peripheral	The FEC performs the full set of IEEE 802.3/Ethernet CSMA/CD media access control and channel interface functions. The FEC supports connection and functionality for the 10/100 Mbps 802.3 media independent interface (MII). It requires an external transceiver (PHY) to complete the interface to the media.	2.3.13/15
GPIO	General Purpose I/O Module	Pins	The GPIO provides 32 bits of bidirectional, general purpose I/O. This peripheral provides dedicated general-purpose pins that can be configured as either inputs or outputs.	2.3.14/16
GPT	General Purpose Timer	Timer Peripheral	The GPT is a multipurpose module used to measure intervals or generate periodic output.	2.3.15/16
I ² C	Inter IC Communication	Connectivity Peripheral	The I ² C provides serial interface to control the sensor interface and other external devices. Data rates of up to 100 Kbits/s are supported.	2.3.16/17

Table 2. Digital and Analog Modules (continued)

Block Mnemonic	Block Name	Functional Grouping	Brief Description	Section/ Page
IIM	IC Identification Module	Security	The IIM provides an interface for reading—and in some cases, programming, and overriding identification and control information stored in on-chip fuse elements. Contact your NXP Semiconductor sales office or distributor for additional information on SCC, RTIC, IIM, SAHARA2	2.3.17/17
JTAGC	JTAG Controller	Debug	The JTAGC provides debug access to the ARM926 core, built-in self-test (BIST), and boundary scan test control.	2.3.18/17
KPP	Keypad Port	Connectivity Peripheral	The KPP is used for key pad matrix scanning or as a general purpose I/O. This peripheral simplifies the software task of scanning a keypad matrix.	2.3.19/17
LCDC	Liquid Crystal Display Controller	Multimedia Interface	The LCDC provides display data for external gray-scale or color LCD panels.	2.3.20/17
M3IF	Multi-Master Memory Interface	External Memory Interface	The M3IF controls memory accesses from one or more masters through different port interfaces to different external memory controllers ESDCTL/MDDRC, PCMCIA, NFC, and WEIM.	2.3.21/18
MAX	Multi-layer AHB Crossbar Switch	Bus Control	The ARM926EJ-S processor's instruction and data buses and all alternate bus master interfaces arbitrate for resources via a 6 × 3 MAX. There are six fully functional master ports (M0–M5) and three fully functional slave ports (S0–S2). The MAX is uni-directional. All master and slave ports are AHB-Lite compliant.	2.3.22/18
MSHC	Memory Stick Host Controller	Connectivity Peripheral	The MSHC is placed in between the AIPI and the customer memory stick to support data transfer from the i.MX27 device to the customer memory stick. Note: The i.MX27L does not support the MSHC feature.	2.3.23/19
NFC	NAND Flash Controller	External Memory Interface	The NFC is a submodule of EMI. The NFC implements the interface to standard NAND Flash memory devices.	2.3.24/19
PCMCIA	Personal Computer Memory Card International Association	External Memory Interface	The PCMCIA host adapter module provides the control logic for PCMCIA socket interfaces, and requires some additional external analog power switching logic and buffering.	2.3.25/20
PLL	Phase Lock Loop	Clock and Reset Control	The two DPLLs provide clock generation in digital and mixed analog/digital chips designed for wireless communication and other applications.	2.3.26/20
PWM	Pulse-Width Modulator	Timer Peripheral	The PWM has a 16-bit counter and is optimized to generate sound from stored sample audio images. It can also generate tones.	2.3.27/20
RTC	Real Time Clock	Timer Peripheral	The RTC module provides a current stamp of seconds, minutes, hours, and days. Alarm and timer functions are also available for programming. The RTC supports dates from the year 1980 to 2050.	2.3.28/20

Table 2. Digital and Analog Modules (continued)

Block Mnemonic	Block Name	Functional Grouping	Brief Description	Section/ Page
RTIC	Run-Time Integrity Checkers	Security	The RTIC ensures the integrity of the contents of the peripheral memory and assists with boot authentication. Contact your NXP Semiconductor sales office or distributor for additional information on SCC, RTIC, IIM, SAHARA2	2.3.29/21
SAHARA2	Symmetric/Asymmetric Hashing and Random Accelerator	Security	SAHARA2 is a security co-processor which forms part of the Platform Independent Security Architecture (PISA), and can be used on cell phone baseband processors or wireless PDAs. Contact your NXP Semiconductor sales office or distributor for additional information on SCC, RTIC, IIM, SAHARA2	2.3.30/21
SCC	Security Controller Module	Security	The SCC is a hardware component composed of two blocks—the Secure RAM module, and the Security Monitor. The Secure RAM provides a way of securely storing sensitive information. The Security Monitor implements the security policy, checking algorithm sequencing, and controlling the Secure State. Contact your NXP Semiconductor sales office or distributor for additional information on SCC, RTIC, IIM, SAHARA2	2.3.31/21
SDHC	Secured Digital Host Controller	Connectivity Peripheral	The SDHC controls the MMC (MultiMediaCard), SD (Secure Digital) memory, and I/O cards by sending commands to cards and performing data accesses to and from the cards.	2.3.32/21
SLCDC	Smart Liquid Crystal Display Controller	Multimedia Interface	The SLCDC module transfers data from the display memory buffer to the external display device.	2.3.33/22
SSI	Synchronous Serial Interface	Multimedia Peripheral	The SSI is a full-duplex, serial port that allows the chip to communicate with a variety of serial devices, such as standard codecs, digital signal processors (DSPs), microprocessors, peripherals, and popular industry audio codecs that implement the inter-IC sound bus standard (I ² S) and Intel AC97 standard.	2.3.34/22
UART	Universal Asynchronous Receiver/Transmitter	Connectivity Peripheral	The UART provides serial communication capability with external devices through an RS-232 cable or through use of external circuitry that converts infrared signals to electrical signals (for reception) or transforms electrical signals to signals that drive an infrared LED (for transmission) to provide low speed IrDA compatibility.	2.3.35/23
USB	Universal Serial Bus—2 Host Controllers and 1 OTG (On-The-Go)	Connectivity Peripherals	The i.MX27/MX27L processors provide two USB Host controllers and one USBOTG of which: <ul style="list-style-type: none"> • USB Host 1 is designed to support transceiverless connection to the on-board peripherals in Low Speed and Full Speed mode, and connection to the ULPI (UTMI+Low-Pin Count) and Legacy Full Speed transceivers • USB Host 2 is designed to support transceiverless connection to the Cellular Modem Baseband Processor • The USBOTG controller offers HS/FS/LS capabilities in Host mode and HS/FS in device mode. In Host mode, the controller supports direct connection of a FS/LS device (without external hub). In device (bypass) mode, the OTG port functions as gateway between the Host 1 Port and the OTG transceiver. 	2.3.36/23

Table 2. Digital and Analog Modules (continued)

Block Mnemonic	Block Name	Functional Grouping	Brief Description	Section/ Page
Video Codec	Video Codec	Hardware Acceleration	Video Codec module supports full duplex video codec with 25 fps VGA image resolution, integrates H.264 BP, MPEG-4 SP and H.263 P3 video processing standard together.	2.3.39/25
WDOG	Watchdog Timer Module	Timer Peripheral	The WDOG module protects against system failures by providing a method for the system to recover from unexpected events or programming errors.	2.3.37/24
WEIM	Wireless External Interface Module	External Memory Interface	The Wireless External Module (WEIM) handles the interface to devices external to chip, including generation of chip selects, clock and control for external peripherals and memory. It provides asynchronous and synchronous access to devices with SRAM-like interface.	2.3.38/25

2.3 Module Descriptions

This section provides a brief text description of all the modules included in the i.MX27/MX27L devices, arranged in alphabetical order.

2.3.1 1-Wire Module

The 1-Wire module provides bi-directional communication between the ARM926 core and the Add-Only Memory EPROM, DS2502. The 1-Kbit EPROM holds information about the battery and communicates with the ARM926 Platform using the IP interface. Through the 1-Wire interface, the ARM926 acts as the bus master while the DS2502 device is the slave. The 1-Wire peripheral does not trigger interrupts; hence it is necessary for the ARM926 to poll the 1-Wire to manage the module. The 1-Wire uses an external pin to connect to the DS2502. Timing requirements are met in hardware with the help of a 1 MHz clock. The clock divider generates a 1 MHz clock that is used as a time reference by the state machine. Timing requirements are crucial for proper operation, and the 1-Wire state machine and the internal clock provide the necessary signal. The clock must be configured to approximately 1 MHz. You can then set the 1-Wire register to send and receive bits over the 1-Wire bus.

2.3.2 AHB-Lite IP Interface Module (APII)

The APII acts as an interface between the Arm Advanced High-performance Bus Lite. (AHB-Lite) and lower bandwidth peripherals conforming to the IP bus specification Rev 2.0. There are two APII modules in i.MX27/MX27L processors.

The following list summarizes the key features of the APII:

- All peripheral read transactions require a minimum of two system clocks (R-AHB side) and all write transactions require a minimum of three system clocks (R-AHB side).
- The APII supports 8-bit, 16-bit, and 32-bit IP bus peripherals. Byte, half word, and full word reads and writes are supported.
- The APII supports multi-cycle accesses by providing 16-bit to 8-bit peripherals operations and 32-bit to both 16-bit and 8-bit peripherals operations.

- The APCI supports 31 external IP bus peripherals each with a 4-Kbyte memory map (a slot).

2.3.3 ARM926EJ-S Interrupt Controller (AIPC)

The ARM926EJ-S Interrupt Controller (AIPC) is a 32-bit peripheral that collects interrupt requests from up to 64 sources and provides an interface to the ARM926EJ-S core. The AIPC includes software controlled priority levels for normal interrupts.

The AIPC performs the following functions:

- Supports up to 64 interrupt sources
- Supports fast and normal interrupts
- Selects normal or fast interrupt request for any interrupt source
- Indicates pending interrupt sources via a register for normal and fast interrupts
- Indicates highest priority interrupt number via register. (Can be used as a table index.)
- Independently can enable or disable any interrupt source
- Provides a mechanism for software to schedule an interrupt
- Supports up to 16 software controlled priority levels for normal interrupts and priority masking
- Can single-bit disable all normal interrupts and all fast interrupts. (Used in enabling of secure operations.)

2.3.4 ARM926EJ-S Platform

The ARM926EJ-S (ARM926) is a member of the Arm9 family of general-purpose microprocessors targeted at multi-tasking applications. The ARM926 supports the 32-bit Arm and 16-bit Thumb instructions sets. The ARM926 includes features for efficient execution of Java byte codes. A JTAG port is provided to support the Arm Debug Architecture, along with associated signals to support the ETM9 real-time trace module. The ARM926EJ-S is a Harvard cached architecture including an ARM9EJ-S integer core, a Memory Management Unit (MMU), separate instruction and data AMBA AHB interfaces, separate instruction and data caches, and separate instruction and data tightly coupled memory (TCM) interfaces. The ARM926 co-processor, instruction TCM, and data TCM interfaces will be tied off within the ARM926 Platform and will not be available for external connection.

The ARM926EJ-S processor is a fully synthesizable macrocell, with a configurable memory system. Both instruction and data caches will be 16 kbytes on the platform. The cache is virtually accessed and virtually tagged. The data cache has physical tags as well. The MMU provides virtual memory facilities which are required to support various platform operating systems such as Symbian OS, Windows CE, and Linux. The MMU contains eight fully associative TLB entries for lockdown and 64 set associative entries. Refer to the *ARM926EJ-S Technical Reference Manual* for more information.

2.3.5 Advanced Technology Attachment (ATA)

The Advanced Technology Attachment (ATA) host controller complies with the ATA/ATAPI-6 specification. The primary use of the ATA host controller is to interface with IDE hard disc drives and Advanced Technology Attachment Packet Interface (ATAPI) optical disc drives. It interfaces with the ATA device over a number of ATA signals.

This host controller supports interface protocols as specified in ATA/ATAPI-6 standard, as follows:

- PIO mode 0, 1, 2, 3, and 4
- Multiword DMA mode 0, 1, and 2
- Ultra DMA modes 0, 1, 2, 3, and 4 with bus clock of 50 MHz or higher
- Ultra DMA mode 5 with bus clock of 80 MHz or higher

Before accessing the ATA bus, the host must program the timing parameters to be used on the ATA bus. The timing parameters control the timing on the ATA bus. Most timing parameters are programmable as a number of clock cycles (1 to 255). Some are implied. All of the ATA device-internal registers are visible to users, and they are defined as mirror registers in ATA host controller. As specified in ATA/ATAPI-6 standard, all the features/functions are implemented by reading/writing to the device's internal registers.

There are basically two protocols that can be active at the same time on the ATA bus, as follows:

- The first and simplest protocol (PIO mode access) can be started at any time by the ARM926 to the ATA bus. The PIO mode is a slow protocol, mainly intended to be used to program an ATA disc drive, but also can be used to transfer data to/from the disc drive.
- The second protocol is the DMA mode access. DMA mode is started by the ATA interface after receiving a DMA request from the drive, and only if the ATA interface has been programmed to accept the DMA request. In DMA mode, either multiword-DMA or ultra-DMA protocol is used on the ATA bus. All transfers between FIFO and the host IP or DMA IP bus are zero wait states transfer, so a high-speed transfer between FIFO and DMA/host bus is possible.

2.3.6 Digital Audio MUX (AUDMUX)

The Digital Audio MUX (AUDMUX) provides programmable interconnecting for voice, audio, and synchronous data routing between host serial interfaces—for example, SSI, SAP, and peripheral serial interfaces—such as, audio and voice codecs. The AUDMUX allows audio system connectivity to be modified through programming, as opposed to altering the design of the system into which the chip is designed. The design of the AUDMUX allows multiple simultaneous audio/voice/data flows between the ports in point-to-point or point-to-multipoint configurations.

Included in the AUDMUX are two types of interfaces. The internal ports connect to the processor serial interfaces, and the external ports connect to off-chip audio devices and serial interfaces of other processors. A desired connectivity is achieved by configuring the appropriate internal and external ports.

The module includes full 6-wire SSI interfaces for asynchronous receive and transmit, as well as a configurable 4-wire (synchronous) or 6-wire (asynchronous) peripheral interface. The AUDMUX allows each host interface to be connected to any other host or peripheral interface in a point-to-point or point-to-multipoint (network mode).

2.3.7 Clock and Reset Module (CRM)

The Clock and Reset Module (CRM) generates clock and reset signals used throughout the i.MX27/MX27L processor and for external peripherals. It also enables system software to control, customize, or read the status of the following functions:

- Chip ID
- Multiplexing of I/O signals
- I/O Driving Strength
- I/O Pull Enable Control
- Well-Bias Control
- System boot mode selection
- DPTC Control

2.3.8 CMOS Sensor Interface (CSI)

The CMOS Sensor Interface (CSI) is a logic interface that enables the i.MX27/MX27L processors to connect directly to external CMOS sensors and CCIR656 video source.

The capabilities of the CSI include the following:

- Configurable interface logic to support popular CMOS sensors in the market
- Support traditional sensor timing interface
- Support CCIR656 video interface, progressive mode for smart sensor, interlace mode for PAL and NTSC input
- 8-bit input port for YCC, YUV, Bayer, or RGB data
- 32 × 32 FIFO storing image data supporting Core data read and DMA data burst transfer to system memory
- Full control of 8-bit and 16-bit data to 32-bit FIFO packing
- Direct interface to eMMA-It Pre-Processing block (PrP) - Not available on the i.MX27L
- Single interrupt source to interrupt controller from maskable sensor interrupt sources: Start of Frame, End of Frame, Change of Field, FIFO full
- Configurable master clock frequency output to sensor
- Asynchronous input logic design. Sensor master clock can be driven by either the i.MX27/MX27L processor or by external clock source.
- Statistic data generation for Auto Exposure (AE) and Auto White Balance (AWB) control of the camera (for Bayer data only)

2.3.9 Configurable Serial Peripheral Interface (CSPI)

The Configurable Serial Peripheral Interface (CSPI) is used for fast data communication with fewer software interrupts. There are three CSPI modules in the i.MX27/MX27L processors, which provide a full-duplex synchronous serial interface, capable of interfacing to the SPI master and slave devices. CSPI1 and CSPI2 are master/slave configurable and include three chip selects to support multiple peripherals. CSPI3 is only a master and has one chip-select signal. The transfer continuation function of the CSPI

enables unlimited length data transfers using 32-bit wide by 8-entry FIFO for both TX and RX data DMA support.

The CSPI Ready (SPI_RDY) and Chip Select (SS) control signals enable fast data communication with fewer software interrupts. When the CSPI module is configured as a master, it uses a serial link to transfer data between the CSPI and an external device. A chip-enable signal and a clock signal are used to transfer data between these two devices. When the CSPI module is configured as a slave, the user can configure the CSPI Control register to match the external SPI master's timing.

2.3.10 Direct Memory Access Controller (DMAC)

The Direct Memory Access Controller (DMAC) provides 16 channels to support linear memory, 2D memory, FIFO, and end-of-burst enable FIFO transfers to support a wide variety of DMA operations. Features include the following:

- Support of 16 channels linear memory, 2D memory, and FIFO for both source and destination
- Support of 8-bit, 16-bit, or 32-bit FIFO port size and memory port size data transfer
- Configurability of DMA burst length of up to a maximum of 16 words, 32 half-words, or 64 bytes for each channel
- Bus utilization control for a channel that is not triggered by DMA request
- Interrupts that are provided to interrupt handler on bulk data transfer complete or transfer error
- DMA burst time-out error to terminate DMA cycle when the burst cannot be completed in a programmed timing period
- Dedicated external DMA request and grant signal
- Support of increment, decrement, and no increment for source and destination addressing
- Support of DMA chaining

2.3.11 *enhanced* MultiMedia Accelerator Light (eMMA_Lt)

The *enhanced* MultiMedia Accelerator Light (eMMA_Lt) consists of the video pre-processor (PrP) and post-processor (PP). In contrast with i.MX21 processor's components, this eMMA does not include the video codec. A more powerful video codec is included as a separate module.

NOTE

The i.MX27L does not have a eMMA_Lt module.

Each module has individual control and configuration registers that are accessed via the IP interface, and are capable of bus mastering the AMBA bus to independently access system memory without any CPU intervention. This enables each module to be used independently of each other, and enables the pre-processor and post-processor modules to provide acceleration features for other software codec implementations and image processing software. These blocks work together to provide video acceleration, and to off-load the CPU from computation intensive tasks. The PrP and PP can be used for generic video pre- and post-processing, such as scaling, resizing, and color space conversions. A 32-bit-to-64-bit AHB gasket is used to convert a PrP AHB bus from a 32-bit to 64-bit protocol. A bypass function is implemented to bypass this 64-bit gasket if it is not needed.

eMMA_It supports the following image/video processing features:

- Pre-processor:
 - Data input:
 - System memory
 - Private DMA between CMOS Sensor Interface module and pre-processor
 - Data input formats:
 - Arbitrarily formatted RGB pixels (16 or 32 bits)
 - YUV 4:2:2 (Pixel interleaved)
 - YUV 4:2:0 (IYUV, YV12)
 - Input image size: 32×32 to 2044×2044
 - Image scaling:
 - Programmable independent CH-1 and CH-2 resizer. Can program to be in cascade or parallel.
 - Each resizer supports downscaling ratios from 1:1 to 8:1 in fractional steps.
 - Channel-1 output data format
 - Channel 1
 - RGB 16 and 32 bpp
 - YUV 4:2:2 (YUYV, YVYU, UYVY, VYUY)
 - Channel-2 output data format
 - YUV 4:2:2 (YUYV)
 - YUV 4:4:4
 - YUV 4:2:0 (IYUV, YV12)
 - RGB data and YUV data format can be generated concurrently
 - 32/64-bit AHB bus
- Post-processor
 - Input data:
 - From system memory
 - Input format:
 - YUV 4:2:0 (IYUV, YV12)
 - Image Size: 32×32 to 2044×2044
 - Output format:
 - YUV 4:2:2 (YUYV)
 - RGB16 and RGB32 bpp
 - Image Resize
 - Upscaling ratios ranging from 1:1 to 1:4 in fractional steps
 - Downscaling ratios ranging from 1:1 to 2:1 in fractional steps and a fixed 4:1
 - Ratios provide scaling between QCIF, CIF, QVGA (320×240 , 240×320)

2.3.12 Enhanced Synchronous Dynamic RAM Controller (ESDRAMC)

The Enhanced Synchronous Dynamic RAM Controller (ESDRAMC) provides an interface and control for synchronous DRAM memories for the system. SDRAM memories use a synchronous interface with all signals registered on a clock edge. A command protocol is used for initialization, read, write, and refresh operations to the SDRAM, and is generated on the signals by the controller (when required due to external or internal requests). It has support for both single data rate RAMs and double data rate SDRAMs. It supports 64 Mbits, 128 Mbits, 256 Mbits, and 512 Mbits, 1 Gbit, 2 Gbits, four bank synchronous DRAM by two independent chip selects and with up to 256 Mbytes addressable memory per chip select.

2.3.13 Fast Ethernet Controller (FEC)

The Fast Ethernet Controller (FEC) is designed to support both 10 and 100 Mbps Ethernet/IEEE Std 802.3™ networks. An external transceiver interface and transceiver function are required to complete the interface to the media. The FEC supports the 10/100 Mbps MII and the 10 Mbps-only 7-wire interface, which uses a subset of the MII pins for connection to an external Ethernet transceiver.

The FEC incorporates the following features:

- Support for three different Ethernet physical interfaces:
 - 100-Mbps IEEE 802.3 MII
 - 10-Mbps IEEE 802.3 MII
 - 10-Mbps 7-wire interface (industry standard)
- IEEE 802.3 full duplex flow control
- Programmable max frame length supports IEEE Std 802.1™ VLAN tags and priority
- Support for full-duplex operation (200 Mbps throughput) with a minimum system clock rate of 50 MHz
- Support for half-duplex operation (100 Mbps throughput) with a minimum system clock rate of 25 MHz
- Retransmission from transmit FIFO following a collision (no processor bus utilization)
- Automatic internal flushing of the receive FIFO for runts (collision fragments) and address recognition rejects (no processor bus utilization)
- Address recognition
 - Frames with broadcast address may be always accepted or always rejected
 - Exact match for single 48-bit individual (unicast) address
 - Hash (64-bit hash) check of individual (unicast) addresses
 - Hash (64-bit hash) check of group (multicast) addresses
 - Promiscuous mode
- Independent DMA engine with multiple channels allowing transmit data, transmit descriptor, receive data, and receive descriptor accesses to provide high performance
- Independent RISC-based controller that provides the following functions in the FEC:
 - Initialization (those internal registers not initialized by the user or hardware)

- High level control of the DMA channels (initiating DMA transfers)
- Interpreting buffer descriptors
- Address recognition for receive frames
- Random number generation for transmit collision backoff timer
- The Message Information Block (MIB) in FEC maintains counters for a variety of network events and statistics. The counters supported are the RMON (RFC 1757) Ethernet Statistics group and some of the IEEE 802.3 counters.

2.3.14 General Purpose I/O Module (GPIO)

The general-purpose input/output (GPIO) module provides dedicated general-purpose pins that can be configured as either inputs or outputs. When it is configured as an output, you can write to an internal register to control the state driven on the output pin. When configured as an input, you can detect the state of the input by reading the state of an internal register. The GPIO includes all of the general purpose input/output logic necessary to drive a specific data to the pad and control the direction of the pad using registers in the GPIO module. The ARM926 is able to sample the status of the corresponding pads by reading the appropriate status register. The GPIO supports up to 32 interrupts and has the ability to identify interrupt edges as well as generate three active high interrupts.

2.3.15 General Purpose Timer (GPT)

The i.MX27/MX27L processors contains six identical 32-bit General Purpose Timers (GPT) with programmable prescalers and compare and capture registers. Each timer's counter value can be captured using an external event, and can be configured to trigger a capture event on the rising or/and falling edges of an input pulse. Each GPT can also generate an event on the TOUT pin, and an interrupt when the timer reaches a programmed value. Each GPT has an 11-bit prescaler that provides a programmable clock frequency derived from multiple clock sources, including ipg_clk_32k, ipg_clk_perclk, ipg_clk_perclk/4, and external clock from the TIN pin. The counter has two operation modes: free-run and restart mode. The GPT can work in low-power mode.

2.3.16 Inter IC Communication (I²C)

Inter IC Communication (I²C) is a two-wire, bidirectional serial bus that provides a simple, efficient method of data exchange, minimizing the interconnection between devices. This bus is suitable for applications requiring occasional communications over a short distance between many devices. The flexible I²C enables additional devices to be connected to the bus for expansion and system development.

The I²C operates up to 400 kbps dependent on pad loading and timing. (For pad requirement details, refer to Phillips I²C Bus Specification, Version 2.1.) The I²C system is a true multiple-master bus, including arbitration and collision detection that prevents data corruption if multiple devices attempt to control the bus simultaneously. This feature supports complex applications with multiprocessor control and can be used for rapid testing and alignment of end products through external connections to an assembly-line computer.

2.3.17 IC Identification Module (IIM)

The IC Identification Module (IIM) provides an interface for reading and in some cases programming and/or overriding identification and control information stored in on-chip fuse elements. The module supports laser fuses (L-Fuses) or electrically-programmable poly fuses (e-Fuses) or both.

Contact your NXP Semiconductor sales office or distributor for additional information on SCC, RTIC, IIM, SAHARA2.

2.3.18 JTAG Controller (JTAGC)

The JTAG Controller (JTAGC) module supports debug access to the ARM926 Platform and tristate enable of the I/O pads. The overall strategy is to achieve good test and debug features without increasing the pin count and reducing the complexity of I/O muxing. The JTAG Controller is compatible with IEEE Std 1149.1™ Standard Test Access Port and Boundary Scan Architecture.

2.3.19 Keypad Port (KPP)

The Keypad Port (KPP) is designed to interface with a keypad matrix with 2-contact or 3-point contact keys. KPP is designed to simplify the software task of scanning a keypad matrix. With appropriate software support, the KPP is capable of detecting, debouncing, and decoding one or multiple keys pressed simultaneously in the keypad. The KPP supports up to 8 × 8 external key pad matrix. Its port pins can be used as general purpose I/O. Using an open drain design, the KPP includes glitch suppression circuit design, multiple keys, long key, and standby key detection.

2.3.20 Liquid Crystal Display Controller (LCDC)

The Liquid Crystal Display Controller (LCDC) provides display data for external gray-scale or color LCD panels. The LCDC is capable of supporting black-and-white, gray-scale, passive-matrix color (passive color or CSTN), and active-matrix color (active color or TFT) LCD panels.

The LCDC provides the following features:

- Configurable AHB bus width (32-bit/64-bit)

- Support for single (non-split) screen monochrome or color LCD panels and self-refresh type LCD panels
- 16 simultaneous gray-scale levels from a palette of 16 for monochrome display
- Support for:
 - Maximum resolution of 800×600
 - Passive color panel:
 - 4 (mapped to RGB444)/8 (mapped to RGB444)/12 (RGB444) bits per pixel (bpp)
 - TFT panel:
 - 4 (mapped to RGB666)/8 (mapped to RGB666)/12 (RGB444)/16 (RGB565)/18 (RGB666) bpp
 - 16 and 256 colors out of a palette of 4096 colors for 4 bpp and 8 bpp CSTN display, respectively
 - 16 and 256 colors out of a palette of 256 colors for 4 bpp and 8 bpp TFT display, respectively
 - True 4096 colors for a 12 bpp display
 - True 64-Kbyte colors for 16 bpp
 - True 256-Kbyte colors for 18 bpp
 - 16-bit AUO TFT LCD Panel
 - 24-bit AUO TFT LCD Panel

2.3.21 Multi-Master Memory Interface (M3IF)/M3IF-ESDCTL/MDDRC Interface

The M3IF-ESDCTL/MDDRC interface is optimized and designed to reduce access latency by generating multiple accesses through the dedicated ESDCTL/MDDRC arbitration (MAB) module, which controls the access to and from the Enhanced SDRAM/MDDR memory controller. For the other port interfaces, the M3IF only arbitrates and forwards the master requests received through the Master Port Gasket (MPG) interface and M3IF Arbitration (M3A) module toward the respective memory controller. The masters that interface with the M3IF include the Arm Platform, FEC, LCDC, H.264, and the USB. The controllers are the ESDCTL/MDDRC, PCMCIA, NFC, and WEIM.

2.3.22 Multi-Layer AHB Crossbar Switch (MAX)

The ARM926EJ-S processor's instruction and data buses—and all alternate bus master interfaces—arbitrate for resources via a 6×34 Multi-Layer AHB Crossbar Switch (MAX). There are six (M0–M5) fully functional master ports and three (S0–S2) fully functional slave ports. The MAX is uni-directional. All master and slave ports are AHB-Lite compliant.

The design of the crossbar switch enables concurrent transactions to proceed from any master port to any slave port. That is, it is possible for all three slave ports to be active at the same time as a result of three independent master requests. If a particular slave port is simultaneously requested by more than one master port, arbitration logic exists inside the crossbar to allow the higher priority master port to be granted the bus, while stalling the other requestor(s) until that transaction has completed. The slave port arbitration

schemes supported are fixed, programmable fixed, programmable default input port parking, and a round robin arbitration scheme.

The Crossbar Switch also monitors the `ccm_br` input (clock control module bus request), which requests a bus grant from all four slave ports. The priority of `ccm_br` is programmable and defaults to the highest priority. Upon receiving bus grants for all four output ports, the `ccm_bg` output will assert. At this point, the clock control and reset module (CRM) can turn off `hclk` and be assured there are no outstanding AHB transactions in progress. Once the CRM is granted a port, no other master will receive a grant on that port until the CRM bus request (`ccm_br`) negates.

2.3.23 Memory Stick Host Controller (MSHC)

The Memory Stick Host Controller (MSHC) is located between the AIPI and the Sony Memory Stick and provides support for data transfers between the i.MX27 processor and the Memory Stick (MS). The MSHC consists of two sub-modules; the MSHC gasket and the Sony Memory Stick Host Controller (SMSC). The SMSC module, which is the actual memory stick host controller, is compatible with Sony Memory Stick Ver 1.x and Memory Stick PRO. The gasket connects the AIPI IP bus to the SMSC interface to allow communication and data transfers via the IP Bus.

NOTE

The i.MX27L does not include the MSHC feature.

The MSHC gasket uses a reduced IP Bus interface that supports the IP bus read/write transfers that include a back-to-back read or write. DMA transfers also take place via the IP Bus interface.

A transfer can be initiated by the DMA or the host (through the AIPI) response to an MSHC DMA request or interrupt. The SMSC has two DMA address modes—a single address mode and a dual address mode.

The MSHC is set to dual-address mode for transfers with the DMA. In dual-address mode, when the MSHC requests a transfer with the DMA request (XDRQ), the DMA will initiate a transfer to the MSHC.

NOTE

Details regarding the operation of the MSHC module can be found separately in *Memory Stick/Memory Stick PRO Host Controller IP Specification 1.3*.

2.3.24 NAND Flash Controller (NFC)

NAND Flash Controller (NFC) interfaces standard NAND Flash devices to the i.MX27/MX27L processors and hides the complexities of accessing the NAND Flash. It provides a glueless interface to both 8-bit and 16-bit NAND Flash parts with page sizes of 512 Bytes or 2 Kbytes. Its addressing scheme enables it to access flash devices of almost limitless capacity. The 2-Kbyte RAM buffer of the NAND Flash is used as the boot RAM during a cold reset (if the i.MX27/MX27L device is configured for a boot to be carried out from the NAND Flash device). After the boot procedure completes, the RAM is available as buffer RAM. In addition, the NAND Flash controller provides an X16-bit and X32-bit interface to the AHB bus on the chip side, and an X8/X16 interface to the NAND Flash device on the external side.

2.3.25 Personal Computer Memory Card International Association (PCMCIA)

The Personal Computer Memory Card International Association (PCMCIA) provides the PCMCIA 2.1 standard, which defines the usage of memory and I/O devices as insertable and exchangeable peripherals for personal computers or PDAs. Examples of these types of devices include CompactFlash and WLAN adapters.

The `pcmcia_if` host adapter module provides the control logic for PCMCIA socket interfaces, and requires some additional external analog power switching logic and buffering. The additional external buffers allow the `pcmcia_if` host adapter module to support one PCMCIA socket. The `pcmcia_if` shares its chip level I/O with the external interface to memory (EIM) pins. Additional logic is required to multiplex the EIM and the `pcmcia_if` on the same pins.

2.3.26 Digital Phase Lock Loop (DPLL)

Two on-chip Digital Phase Lock Loop (DPLLs) provide clock generation in digital and mixed analog/digital chips designed for wireless communication and other applications. The DPLLs produce a high-frequency chip clock signals with a low frequency and phase jitter.

2.3.27 Pulse-Width Modulator (PWM)

The Pulse-Width Modulator (PWM) has a 16-bit counter and is optimized to generate sounds from stored sample audio images; it can also generate tones. The PWM uses 16-bit resolution and a 4×16 data FIFO to generate sound. The 16-bit up-counter has a source selectable clock with 4×16 FIFO to minimize interrupt overhead. Clock-in frequency is controlled by a 12-bit prescaler for the division of a clock. Capable of sound and melody generation, the PWM has an active-high or active-low configurable output, and can be programmed to be active in low-power and debug modes. The PWM can be programmed to generate interrupts at compare and rollover events.

2.3.28 Real Time Clock (RTC)

The Real Time Clock (RTC) module maintains the system clock, provides stopwatch, alarm, and interrupt functions, and supports the following features:

- Full clock—days, hours, minutes, seconds
- Minute countdown timer with interrupt
- Programmable daily alarm with interrupt
- Sampling timer with interrupt
- Once-per-day, once-per-hour, once-per-minute, and once-per-second interrupts
- Operation at 32.768 kHz or 32 kHz, or 38.4 kHz (determined by reference clock crystal)

The prescaler converts the incoming crystal reference clock to a 1 Hz signal, which is used to increment the seconds, minutes, hours, and days TOD counters. The alarm functions, when enabled, generate RTC interrupts when the TOD settings reach programmed values. The sampling timer generates fixed-frequency interrupts, and the minute stopwatch allows for efficient interrupts on very small boundaries.

2.3.29 Run-Time Integrity Checker (RTIC)

The Run-Time Integrity Checker (RTIC) is one of the security components in the i.MX27/MX27L processors. Its purpose is to ensure the integrity of the peripheral memory contents and assist with boot authentication. The RTIC has the ability to verify the memory contents during system boot and during run-time execution. If the memory contents at runtime fail to match the hash signature, an error in the security monitor is triggered.

Contact your NXP Semiconductor sales office or distributor for additional information on SCC, RTIC, IIM, SAHARA2.

2.3.30 Symmetric/Asymmetric Hashing and Random Accelerator (SAHARA2)

SAHARA2 is a security co-processor, it implements encryption algorithms (AES, DES, and 3DES), hashing algorithms (MD5, SHA-1, SHA_224, and SHA-256), stream cipher algorithm (ARC4), and a hardware random number generator.

Contact your NXP Semiconductor sales office or distributor for additional information on SCC, RTIC, IIM, SAHARA2.

2.3.31 Security Controller Module (SCC)

The Security Controller Module (SCC) is a hardware security component. Overall, its primary functionality is associated with establishing a centralized security state controller and hardware security state with a hardware configured, unalterable security policy.

Contact your NXP Semiconductor sales office or distributor for additional information on SCC, RTIC, IIM, and SAHARA2.

2.3.32 Secure Digital Host Controller (SDHC)

The Secure Digital Host Controller (SDHC) controls the MultiMedia Card (MMC), Secure Digital (SD) memory, and I/O cards by sending commands to cards and performing data accesses to/from the cards. The Multimedia Card/Secure Digital Host (MMC/SD) module integrates both MMC support along with SD memory and I/O functions. The SDHC is fully compatible with the MMC System Specification Version 3.0, as well as with the SD Memory Card Specification 1.0, and SD I/O Specification 1.0 with 1/4 channel(s). The maximum data rate in 4-bit mode is 100 Mbps. The SDHC uses a built-in programmable frequency counter for the SDHC bus, and provides a maskable hardware interrupt for an SDIO interrupt, internal status, and FIFO status. It has a pair of 32×16 -bit data FIFO buffers built in.

The MultiMedia Card (MMC) is a universal, low-cost data storage and communication media that is designed to cover a wide area of applications, including, for example, electronic toys, organizers, PDAs, and smart phones. The MMC communication is based on an advanced 7-pin serial bus designed to operate in a low-voltage range.

The Secure Digital Card (SD) is an evolution of MMC technology, with two additional pins in the form factor. It is specifically designed to meet the security, capacity, performance, and environment requirements inherent in newly emerging audio and video consumer electronic devices. The physical form

factor, pin assignment, and data transfer protocol are forward-compatible with the MultiMedia Card with some additions. Under SD, it can be categorized into Memory and I/O. The memory card invokes a copyright protection mechanism that complies with the security of the SDMI standard, which is faster and provides the capability for a higher memory capacity. The I/O card provides high-speed data I/O with low-power consumption for mobile electronic devices.

2.3.33 Smart Liquid Crystal Display Controller Module (SLCDC)

The Smart Liquid Crystal Display Controller (SLCDC) module transfers data from the display memory buffer to the external display device. Direct Memory Access (DMA) transfers the data transparently with minimal software intervention. Bus utilization of the DMA is controllable and deterministic.

As cellular phone displays become larger and more colorful, demands on the processor increase. More CPU power is needed to render and manage the image. The role of the display controller is to reduce the CPU's involvement in the transfer of data from memory to the display device so the CPU can concentrate on image rendering. DMA is used to optimize the transfer. Embedded control information needed by the display device is automatically read from a second buffer in system memory and inserted into the data stream at the proper time to completely eliminate the CPU's role in the transfer.

A typical scenario for a cellular phone display is to have the display image rendered in main system memory. After the image is complete, the CPU triggers the SLCDC module to transfer the image to the display device. Image transfer is accomplished by burst DMA, which steals bus cycles from the CPU. Cycle-stealing behavior is programmable so bus use is kept within predefined bounds. After the transfer is complete, a maskable interrupt is generated indicating the status. For animated displays, it is suggested that a two-buffer ping-pong scheme be implemented so that the DMA is fetching data from one buffer while the next image is rendered into the other.

Several display sizes and types are used in the various products that use the SLCDC. The SLCDC module has the capability of directly interfacing to the selected display devices. Both serial and parallel interfaces are supported. The SLCDC module only supports writes to the display controller. SLCDC read operations from the display controller are not supported.

2.3.34 Synchronous Serial Interface (SSI)

The Synchronous Serial Interface (SSI) is a full-duplex serial port that allows the chip to communicate with a variety of serial devices. These serial devices can be standard codecs, Digital Signal Processors (DSPs), microprocessors, peripherals, and popular industry audio codecs that implement the inter-IC sound bus standard (I²S) and Intel AC97 standard.

The SSI is typically used to transfer samples in a periodic manner. The SSI consists of independent transmitter and receiver sections with independent clock generation and frame synchronization.

The SSI contains independent (asynchronous) or shared (synchronous) transmit and receive sections with separate or shared internal/external clocks and frame syncs, operating in Master or Slave mode. The SSI can work in Normal mode operation using frame sync, and in Network mode operation allowing multiple devices to share the port with as many as thirty-two time slots.

The SSI provides two sets of Transmit and Receive FIFOs. Each of the four FIFOs is 8 × 24 bits. The two sets of Tx/RX FIFOs can be used in Network mode to provide two independent channels for transmission

and reception. It also has programmable data interface modes such as I2S, LSB, and MSB aligned and programmable word lengths. Other program options include frame sync, clock generation, and programmable I2S modes (Master, Slave, or Normal). Oversampling clock, `ccm_ssi_clk` is available as output from SRCK in I2S Master mode.

In addition to AC97 support, the SSI has completely separate clock and frame sync selections for the receive and transmit sections. In the AC97 standard, the clock is taken from an external source and frame sync is generated internally. The SSI also has a programmable internal clock divider and Time Slot Mask registers for reduced CPU overhead (for Tx and RX both).

2.3.35 Universal Asynchronous Receiver/Transmitter (UART)

The i.MX27/MX27L processors contain six UART modules. Each UART module is capable of standard RS-232 non-return-to-zero (NRZ) encoding format and IrDA-compatible infrared modes. The UART provides serial communication capability with external devices through an RS-232 cable or through use of external circuitry that converts infrared signals to electrical signals (for reception); or it transforms electrical signals to signals that drive an infrared LED (for transmission) to provide low-speed IrDA compatibility.

The UART transmits and receives characters that are either 7 or 8 bits in length (program selectable). To transmit, data is written from the peripheral data bus to a 32-byte transmitter FIFO (TxFIFO). This data is passed to the shift register and shifted serially out on the transmitter pin (TXD). To receive, data is received serially from the receiver pin (RXD) and stored in a 32-half-word-deep receiver FIFO (RxFIFO). The received data is retrieved from the RxFIFO on the peripheral data bus. The RxFIFO and TxFIFO generate maskable interrupts as well as DMA requests when the data level in each of the FIFO reaches a programmed threshold level.

The UART generates baud rates based on a programmable divisor and input clock. The UART also contains programmable auto baud detection circuitry to receive 1 or 2 stop bits as well as odd, even, or no parity. The receiver detects framing errors, idle conditions, BREAK characters, parity errors, and overrun errors.

2.3.36 Universal Serial Bus (USB)

The i.MX27/MX27L processors provide three USB ports. The USB module provides high performance USB On-The-Go (OTG) functionality, compliant with the USB 2.0 specification, the OTG supplement, and the ULPI 1.0 Low Pin Count specification. The module consists of three independent USB cores, each controlling one USB port.

In addition to the USB cores, the USB module provides for Transceiverless Link (TLL) operation on host Ports 1 and 2, and provides the ability of routing the OTG transceiver interface to Host Port 1 such that this transceiver can be used to communicate with a USB peripheral connected to Host Port 1. The USB module has two connections to the CPU bus—one IP-bus connection for register accesses and one AHB-bus connection for the DMA transfer of data to and from the FIFOs.

The USB module includes the following features:

- Full Speed/Low speed Host only core (HOST 1)
- Transceiverless Link Logic (TLL) for on board connection to a FS/LS USB peripheral

Functional Description and Application Information

- Bypass mode to route Host Port 1 signals to OTG I/O port
- High Speed /Full Speed/Low Speed Host Only core (Host 2)
- Full Speed/Low Speed interface for Serial transceiver
- TLL function for direct connection to USB peripheral in FS/LS (serial) operation
- High-speed OTG core

The USB module has two main modes of operation: Normal mode and Bypass mode. Furthermore, the USB interfaces can be configured for high-speed operation (480 Mbps) and/or full/low speed operation (12/1.5 Mbps). In Normal mode, each USB core controls its corresponding port. In addition to the major operational modes, each port can work in one or more modes, as follows:

PHY mode In PHY mode, an external serial transceiver is connected to the port. This is used for off-board USB connections.

TLL mode In TLL mode, internal logic is enabled to emulate the functionality of two back-to-back connected transceivers. This mode is typically used for on-board USB connections to USB-capable peripherals.

Host Port 2 supports ULPI and Serial Transceivers. The OTG port requires a transceiver and is intended for off-board USB connections.

Serial Interface mode In serial mode, a serial OTG transceiver must be connected. The port does not support dedicated signals for OTG signaling. Instead, a transceiver with built-in OTG registers must be used. Typically, the transceiver registers are accessible over an I²C or SPI interface.

ULPI mode In this mode, a ULPI transceiver is connected to the port pins to support high-speed off board USB connection.

Bypass mode Bypass mode affects the operation of the OTG port and Host Port 1. This mode is only available when a serial transceiver is used on the OTG port, and the peripheral device on Port 1 is using a TLL connection. Bypass mode is activated by setting the bypass bit in the USBCONTROL register. In this mode, the USB OTG port connections are internally routed to the USB Host 1 port, such that the transceiver on the OTG port connects to a peripheral USB device on Host Port 1. The OTG core and the Host 1 core are disconnected from their ports when bypass is active.

Low Power mode Each of the three USB cores has an associated power control module that is controlled by the USB core and clocked on a 32-kHz clock. When a USB bus is idle, the transceiver can be placed in low-power mode (suspend), after which the clocks to the USB core can be stopped. The 32-kHz low power clock must remain active as it is needed for walk-up detection.

2.3.37 Watchdog Timer Module (WDOG)

The Watchdog Timer module (WDOG) protects against system failures by providing a method of escaping from unexpected events or programming errors. Once the WDOG module is activated, it must be serviced by software on a periodic basis. If servicing does not take place, the timer times out. Upon a time-out, the WDOG Timer module either asserts the `wdog` signal or a system reset signal `wdog_rst`, depending on software configuration. The WDOG Timer module also generates a system reset via a software write to

the Watchdog Control Register (WCR) when there is a detection of a clock monitor event, an external reset, an external JTAG reset signal, or if a power-on-reset has occurred.

2.3.38 Wireless External Interface Module (WEIM)

The Wireless External Interface Module (WEIM) handles the interface to devices external to the chip, including generation of chip selects, clocks and controls for external peripherals and memory. It provides asynchronous and synchronous access to devices with an SRAM-like interface.

The WEIM includes six chip selects for external devices, with two CS signals covering a range of 128 Mbytes, and the other four each covering a range of 32 Mbytes. The 128-Mbyte range can be increased to 256 Mbytes when combined with the two signals. The WEIM offers selectable protection for each chip select as well as programmable data port size. There is a programmable wait-state generator for each chip select and support for Big Endian and Little Endian modes of operation per access.

2.3.39 Video Codec

The Video Codec module is the video processing module in the i.MX27 processor. It supports full duplex video codec with 25 fps VGA resolution, supports multi-party calls, and integrates multiple video processing standards, including H.264 BP, MPEG-4 SP, and H.263 P3 (including annex I, J, K, and T), D1 resolution, 30 fps—half-duplex.

NOTE

The Video Codec feature is not available on the i.MX27L.

It has three 64-bit AHB-Lite master bus interfaces connecting to the EMI, which includes two read channels and one write channel. Its 32-bit AHB-Lite master bus is connected to Arm Platform to access system-internal SRAM.

The Video Codec module contains three major architectural components: video codec processing IP, AXI-to-AHB bus protocol transfer module, and a 32-bit to 64-bit AHB master bus protocol transfer module.

The Video Codec module supports following video stream processing features:

- Multi-standard video codec
 - MPEG-4 part-II simple profile encoding/decoding
 - H.264/AVC baseline profile encoding/decoding
 - H.263 P3 encoding/decoding
 - Multi-party call: max processing four image/bitstream encoding and/or decoding simultaneously
 - Multi-format: for example, encodes MPEG-4 bitstream, and decodes H.264 bitstream simultaneously
- Coding tools
 - High-performance motion estimation
 - Single reference frame for both MPEG-4 and H.264 encoding
 - Support 16 reference frame for H.264 decoding

Signal Descriptions

- Quarter-pel and half-pel accuracy motion estimation
- $[\pm 16, \pm 16]$ Search range
- Unrestricted motion vector
- All variable block sizes are supported (in case of encoding, 8×4 , 4×8 , and 4×4 block sizes are not supported).
- MPEG-4 AC/DC prediction and H.264 Intra prediction
- H.263 Annex I, J, K(RS = 0 and ASO =0), and T are supported. In case of encoding, the Annex I and K(RS=1 or ASO=1) are not supported.
- CIR (Cyclic Intra Refresh)/AIR (Adaptive Intra Refresh)
- Error resilience tools
 - MPEG-4 re-synchronize marker and data-partitioning with RVLC (fixed number of bits/macroblocks between macroblocks)
 - H.264/AVC FMO and ASO
 - H.263 slice structured mode
- Bit-rate control (CBR and VBR)
- Pre/post rotation/mirroring
 - 8 rotation/mirroring modes for image to be encoded
 - 8 rotation/mirroring modes for image to be displayed
- Programmability
 - Embeds 16-bit DSP processor that is dedicated to processing bitstream and driving codec hardware
 - General purpose registers and interrupt generation for communication between system and video codec module

3 Signal Descriptions

This section discusses the following:

- Identifies and defines all device signals in text, tables, and (as appropriate) figures. Signals can be organized by group, as applicable.
- Contains pin-assignment/contact-connection diagrams, if the sequence of information in the data sheet requires them to be included here.

Table 3 shows the i.MX27/MX27L signal descriptions.

Table 3. i.MX27/MX27L Signal Descriptions

Pad Name	Function/Notes
External Bus/Chip Select (EMI)	
A [13:0]	Address bus signals, shared with SDRAM/MDDR, WEIM and PCMCIA, A[10] for SDRAM/MDDR is not the address but the pre-charge bank select signal.
MA10	Address bus signals for SDRAM/MDDR

Table 3. i.MX27/MX27L Signal Descriptions (continued)

Pad Name	Function/Notes
A [25:14]	Address bus signals, shared with WEIM and PCMCIA
SDBA[1:0]	SDRAM/MDDR bank address signals
SD[31:0]	Data bus signals for SDRAM, MDDR
SDQS[3:0]	MDDR data sample strobe signals
DQM0–DQM3	SDRAM data mask strobe signals
EB0	Active low external enable byte signal that controls D [15:8], shared with PCMCIA $\overline{PC_REG}$.
EB1	Active low external enable byte signal that controls D [7:0], shared with PCMCIA $\overline{PC_IORD}$.
\overline{OE}	Memory Output Enable—Active low output enables external data bus, shared with PCMCIA $\overline{PC_IOWR}$.
\overline{CS} [5:0]	Chip Select—The chip select signals \overline{CS} [3:2] are multiplexed with \overline{CSD} [1:0] and are selected by the Function Multiplexing Control Register (FMCR) in the System Control chapter. By default \overline{CSD} [1:0] is selected. \overline{DTACK} is multiplexed with $\overline{CS4}$. \overline{CS} [5:4] are multiplexed with ETMTRACECLK and ETMTRACESYNC; PF22, 21.
ECB	Active low input signal sent by flash device to the EIM whenever the flash device must terminate an on-going burst sequence and initiate a new (long first access) burst sequence.
LBA	Active low signal sent by flash device causing external burst device to latch the starting burst address.
BCLK	Clock signal sent to external synchronous memories (such as burst flash) during burst mode.
\overline{RW}	\overline{RW} signal—Indicates whether external access is a read (high) or write (low) cycle. This signal is also shared with the PCMCIA $\overline{PC_WE}$.
RAS	SDRAM/MDDR Row Address Select signal
CAS	SDRAM/MDDR Column Address Select signal
SDWE	SDRAM Write Enable signal
SDCKE0	SDRAM Clock Enable 0
SDCKE1	SDRAM Clock Enable 1
SDCLK	SDRAM Clock
SDCLK_B	SDRAM Clock_B
NFWE_B	NFC Write enable signal, multiplexed with ETMPIPESTAT2; PF6
NFRE_B	NFC Read enable signal, multiplexed with ETMPIPESTAT1; PF5
NFALE	NFC Address latch signal, multiplexed with ETMPIPESTAT0; PF4
NFCLE	NFC Command latch signal, multiplexed with ETMTRACEPKT0; PF1
NFWP_B	NFC Write Permit signal, multiplexed with ETMTRACEPKT1; PF2
NFCE_B	NFC Chip enable signal, multiplexed with ETMTRACEPKT2; PF3
NFRB	NFC read Busy signal, multiplexed with ETMTRACEPKT3; PF0
D[15:0]	Data Bus signal, shared with EMI, PCMCIA, and NFC

Table 3. i.MX27/MX27L Signal Descriptions (continued)

Pad Name	Function/Notes
PC_CD1_B	PCMCIA card detect signal, multiplexed with ATA ATA_DIOR signal; PF20
PC_CD2_B	PCMCIA card detect signal, multiplexed with ATA ATA_DIOW signal; PF19
PC_WAIT_B	PCMCIA WAIT signal, multiplexed with ATA ATA_CS1 signal; PF18
PC_READY	PCMCIA READY/IRQ signal, multiplexed with ATA ATA_CS0 signal; PF17
PC_PWRON	PCMCIA signal, multiplexed with ATA ATA_DA2 signal; PF16
PC_VS1	PCMCIA voltage sense signal, multiplexed with ATA ATA_DA1 signal; PF14
PC_VS2	PCMCIA voltage sense signal, multiplexed with ATA ATA_DAO signal; PF13
PC_BVD1	PCMCIA Battery voltage detect signal, multiplexed with ATA ATA_DMARQ signal; PF12
PC_BVD2	PCMCIA Battery voltage detect signal, multiplexed with ATA ATA_DMACK signal; PF11
PC_RST	PCMCIA card reset signal, multiplexed with ATA ATA_RESET_B signal; PF10
IOIS16	PCMCIA mode signal, multiplexed with ATA ATA_INTRQ signal; PF9
PC_RW_B	PCMCIA read write signal, multiplexed with ATA ATA_IORDY signal; PF8
PC_POE	PCMCIA output enable signal, multiplexed with ATA ATA_BUFFER_EN signal; PF7
Clocks and Resets	
CLKO	Clock Out signal selected from internal clock signals. Refer to the clock controller for internal clock selection; PF15.
EXT_60M	This is a special factory test signal. To ensure proper operation, connect this signal to ground.
EXT_266M	This is a special factory test signal. To ensure proper operation, connect this signal to ground.
OSC26M_TEST	This is a special factory test signal. To ensure proper operation, leave this signal as a no connect.
RESET_IN	Master Reset—External active low Schmitt trigger input signal. When this signal goes active, all modules (except the reset module, SDRAMC module, and the clock control module) are reset.
RESET_OUT	Reset_Out—Output from the internal Hreset_b; and the Hreset can be caused by all reset source: power on reset, system reset (RESET_IN), and watchdog reset.
POR	Power On Reset—Active low Schmitt trigger input signal. The $\overline{\text{POR}}$ signal is normally generated by an external RC circuit designed to detect a power-up event.
XTAL26M	Oscillator output to external crystal
EXTAL26M	Crystal input (26 MHz), or a 16 MHz to 32 MHz oscillator (or square-wave) input when internal oscillator circuit is shut down.
CLKMODE[1:0]	These are special factory test signals. To ensure proper operation, do not connect to these signals.
EXTAL32K	32 kHz crystal input (Note: in the RTC power domain)
XTAL32K	Oscillator output to 32 kHz crystal (Note: in the RTC power domain)
Power_cut	(Note: in the RTC power domain)
Power_on_reset	(Note: in the RTC power domain)

Table 3. i.MX27/MX27L Signal Descriptions (continued)

Pad Name	Function/Notes
osc32k_bypass	The signal for osc32k input bypass (Note: in the RTC power domain)
Bootstrap	
BOOT [3:0]	System Boot Mode Select—The operational system boot mode of the i.MX27/MX27L processor upon system reset is determined by the settings of these pins. BOOT[1:0] are also used as handshake signals to PMIC(VSTBY).
JTAG	
JTAG_CTRL	JTAG Controller select signal—JTAG_CTRL is sampled during rising edge of TRST. Must be pulled to logic high for proper JTAG interface to debugger. Pulling JTAG_CTRL low is for internal test purposes only.
TRST	Test Reset Pin—External active low signal used to asynchronously initialize the JTAG controller.
TDO	Serial Output for test instructions and data. Changes on the falling edge of TCK.
TDI	Serial Input for test instructions and data. Sampled on the rising edge of TCK.
TCK	Test Clock to synchronize test logic and control register access through the JTAG port.
TMS	Test Mode Select to sequence JTAG test controller's state machine. Sampled on rising edge of TCK.
RTCK	JTAG Return Clock used to enhance stability of JTAG debug interface devices. This signal is multiplexed with 1-Wire; thus, utilizing 1-Wire will render RTCK unusable and vice versa; PE16.
Secure Digital Interface (X2)	
SD1_CMD	SD Command bidirectional signal—If the system designer does not want to make use of the internal pull-up, via the Pull-up enable register, a 4.7K–69K external pull up resistor must be added. This signal is multiplexed with CSPI3_MOSI; PE22.
SD1_CLK	SD Output Clock. This signal is multiplexed with CSPI3_SCLK; PE23.
SD1_D[3:0]	SD Data bidirectional signals—If the system designer does not want to make use of the internal pull-up, via the Pull-up enable register, a 50K–69K external pull up resistor must be added. SD1_D[3] is muxed with CSPI3_SS while SD1_D[0] is muxed with CSPI3_MISO PE21–18.
SD2_CMD	SD Command bidirectional signal. This signal is multiplexed with MSHC_BS; through GPIO multiplexed with SLCDC1_CS; PB8.
SD2_CLK	SD Output Clock signal. This signal is multiplexed with MSHC_SCLK, through GPIO multiplexed with SLCDC1_CLK; PB9.
SD2_D[3:0]	SD Data bidirectional signals. SD2_D[3:0] multiplexed with MSHC_DATA[0:3], also through GPIO SD2_1:0] multiplexed with SLCDC1_RS and SLDCD1_D0; PB7–PB4.
SD3_CMD	SD Command bidirectional signal. This signal is through GPIO PD0 multiplexed with FEC_TXD0.
SD3_CLK	SD Output Clock signal. This signal is multiplexed with ETMTRACEPKT15 and also through GPIO PD1 multiplexed with FEC_TXD1.
Note: SD3_DATA is multiplexed with ATA_DATA3–0.	
UARTs (X6)	
UART1_RTS	Request to Send input signal; PE15

Table 3. i.MX27/MX27L Signal Descriptions (continued)

Pad Name	Function/Notes
UART1_CTS	Clear to Send output signal; PE14
UART1_RXD	Receive Data input signal; PE13
UART1_TXD	Transmit Data output signal, PE12
UART2_RXD	Receive Data input signal. This signal is multiplexed with KP_ROW6 signal from KPP; PE7.
UART2_TXD	Transmit Data output signal. This signal is multiplexed with KP_COL6 signal from KPP; PE6.
UART2_RTS	Request to Send input signal. This signal is multiplexed with KP_ROW7 signal from KPP; PE4.
UART2_CTS	Clear to Send output signal. This signal is multiplexed with KP_COL7 signal from KPP; PE3.
UART3_RTS	Request to Send input signal, PE11
UART3_CTS	Clear to Send output signal; PE10
UART3_RXD	Receive Data input signal; PE9
UART3_TXD	Transmit Data output signal; PE8
Note: UART 4, 5, and 6 are multiplexed with COMS Sensor Interface signals.	
Keypad	
KP_COL[5:0]	Keypad Column selection signals. KP_COL[7:6] are multiplexed with $\overline{\text{UART2_CTS}}$ and $\overline{\text{UART2_TXD}}$ respectively. Alternatively, KP_COL6 is also available on the internal factory test signal TEST_WB2. The Function Multiplexing Control Register in the System Control chapter must be used in conjunction with programming the GPIO multiplexing (to select the alternate signal multiplexing) to choose which signal KP_COL6 is available.
KP_ROW[5:0]	Keypad Row selection signals. KP_ROW[7:6] are multiplexed with $\overline{\text{UART2_RTS}}$ and $\overline{\text{UART2_RXD}}$ signals respectively. The Function Multiplexing Control Register in the System Control chapter must be used in conjunction with programming the GPIO multiplexing (to select the alternate signal multiplexing) to choose which signals KP_ROW6 and KP_ROW7 are available.
Note: KP_COL[7:6] and KP_ROW[7:6] are multiplexed with UART2 signals as show above, also see UARTs table.	
PWM	
PWMO	PWM Output. This signal is multiplexed with PC_SPKOUT of PCMCIA, as well as TOUT2 and TOUT3 of the General Purpose Timer module; PE5.
CSPI (X3)	
CSPI1_MOSI	Master Out/Slave In signal, PD31
CSPI1_MISO	Master In/Slave Out signal, PD30
CSPI1_SS[2:0]	Slave Select (Selectable polarity) signal, the CSPI1_SS2 is multiplexed with USBH2_DATA5/RVCV; and CSPI1_SS1 is multiplexed with $\overline{\text{EXT_DMAGRANT}}$; PD26–28.
CSPI1_SCLK	Serial Clock signal, PD29
CSPI1_RDY	Serial Data Ready signal, shared with Ext_DMAREq_B signal; PD25
CSPI2_MOSI	Master Out/Slave In signal, multiplexed with USBH2_DATA1/TXDP; PD24
CSPI2_MISO	Master In/Slave Out signal, multiplexed with USBH2_DATA2/TXDm; PD23

Table 3. i.MX27/MX27L Signal Descriptions (continued)

Pad Name	Function/Notes
CSPI2_SS[2:0]	Slave Select (Selectable polarity) signals, multiplexed with USBH2_DATA4/RXDM, USBH2_DATA3/RXDP, USBH2_DATA6/SPEED; PD19–PD21
CSPI2_SCLK	Serial Clock signal, multiplexed with USBH2_DATA0/OEn; PD22
Note: CSPI3 CSPI3_MOSI, CSPI3_MISO, CSPI3_SS, and CSPI3_SCLK are multiplexed with SD1 signals.	
I²C	
I2C2_SCL	I ² C2 Clock, through GPIO, multiplexed with SLCDC_data8; PC6
I2C2_SDA	I ² C2 Data, through GPIO, multiplexed with SLCDC_data7; PC5
I2C_CLK	I ² C1 Clock; PD18
I2C_DATA	I ² C1 Data; PD17
CMOS Sensor Interface	
CSI_HSYNC	Sensor port horizontal sync, multiplexed with UART5_RTSP; PB21
CSI_VSYNC	Sensor port vertical sync, multiplexed with UART5_CTS; PB20
CSI_D7	Sensor port data, multiplexed with UART5_RXD; PB19
CSI_D6	Sensor port data, multiplexed with UART5_TXD; PB18
CSI_D5	Sensor port data; PB17
CSI_PIXCLK	Sensor port data latch clock; PB16
CSI_MCLK	Sensor port master clock, PB15
CSI_D4	Sensor port data, PD14
CSI_D3	Sensor port data, multiplexed with UART6_RTS; PB13
CSI_D2	Sensor port data, multiplexed with UART6_CTS; PB12
CSI_D1	Sensor port data, multiplexed with UART6_RXD; PB11
CSI_D0	Sensor port data, multiplexed with UART6_TXD; PB10
Serial Audio Port—SSI (Configurable to I2S Protocol and AC97) (2 to 4)	
SSI1_CLK	Serial clock signal that is output in master or input in slave; PC23
SSI1_TXD	Transmit serial data; PC22
SSI1_RXD	Receive serial data; PC21
SSI1_FS	Frame Sync signal that is output in master and input in slave; PC20
SSI2_CLK	Serial clock signal that is output in master or input in slave, multiplexed with GPT4_TIN. PC27
SSI2_TXD	Transmit serial data signal, multiplexed with GPT4_TOUT; PC26
SSI2_RXD	Receive serial data, multiplexed with GPT5_TIN; PC25
SSI2_FS	Frame Sync signal which is output in master and input in slave, multiplexed with GPT5_TOUT: PC24

Table 3. i.MX27/MX27L Signal Descriptions (continued)

Pad Name	Function/Notes
SSI3_CLK	Serial clock signal which is output in master or input in slave. This signal is multiplexed with SLCDC2_CLK; through GPIO multiplexed with PC_WAIT_B; PC31.
SSI3_TXD	Transmit serial data signal which is multiplexed with SLCDC2_CS, through GPIO multiplexed with PC_READY; PC30
SSI3_RXD	Receive serial data which is multiplexed with SLCDC2_RS; through GPIO multiplexed with PC_VS1; PC29
SSI3_FS	Frame Sync signal which is output in master and input in slave. This signal is multiplexed with SLCDC2_D0; through GPIO multiplexed with PC_VS1; PC28.
SSI4_CLK	Serial clock signal which is output in master or input in slave; through GPIO multiplexed with PC_BVD1; PC19
SSI4_TXD	Transmit serial data; through GPIO multiplexed with PC_BVD2; PC18
SSI4_RXD	Receive serial data; through GPIO multiplexed with IOIS16; PC17
SSI4_FS	Frame Sync signal which is output in master and input in slave; PC16
General Purpose Timers (X6)	
TIN	Timer Input Capture or Timer Input Clock—The signal on this input is applied to GPT 1–3 simultaneously. This signal is muxed with the Walk-up Guard Mode \overline{WKGD} signal in the PLL, Clock, and Reset Controller module, and is also multiplexed with GPT6_TOUT; PC15.
TOUT1	Timer Output signal from General Purpose Timer1 (GPT1). This signal is multiplexed with SSI1_MCLK and SSI2_MCLK signal of SSI1 and SSI2. The pin name of this signal is simply TOUT, and is also multiplexed with GPT6_TIN; PC14.
Note: TOUT2, TOUT3 are multiplexed with PWMO pad; GPT4 and GPT5 signals are multiplexed with SSI2 pads.	
USB2.0	
USBOTG_DIR/TXDM	USB OTG direction/Transmit Data Minus signal, multiplexed with KP_ROW7A; PE2
USBOTG_STP/TXDM	USB OTG Stop signal/Transmit Data Minus signal, multiplexed with KP_ROW6A; PE1
USBOTG_NXT/TXDM	USB OTG NEXT/Transmit Data Minus signal, multiplexed with KP_COL6A; PE0
USBOTG_CLK/TXDM	USB OTG Clock/Transmit Data Minus signal, PE24
USBOTG_DATA7/SUSPEND	USB OTG Data7/Suspend signal, PE25
USBH2_STP/TXDM	USB Host2 Stop signal/Transmit Data Minus signal, PA4
USBH2_NXT/TXDM	USB Host2 NEXT/Transmit Data Minus signal, PA3
USBH2_DATA7/SUSPEND	USB Host2 Data7/Suspend signal, PA2
USBH2_DIR/TXDM	USB Host2 Direction/Transmit Data Minus signal, PA1
USBH2_CLK/TXDM	USB Host2 Clock/Transmit Data Minus signal; PA0
USBOTG_DATA3/RXDP	USB OTG data4/Receive Data Plus signal; multiplexed with SLCDC1_DAT15 through PC13
USBOTG_DATA4/RXDM	USB OTG data4/Receive Data Minus signal; multiplexed with SLCDC1_DAT14 through PC12
USBOTG_DATA1/TXDP	USB OTG data1/Transmit Data Plus signal; multiplexed with SLCDC1_DAT13 through PC11
USBOTG_DATA2/TXDm	USB OTG data2/Transmit Data Minus signal; multiplexed with SLCDC1_DAT12 through PC10

Table 3. i.MX27/MX27L Signal Descriptions (continued)

Pad Name	Function/Notes
USBOTG_DATA0/Oen	USB OTG data0/Output Enable signal; multiplexed with SLCDC1_DAT11 through PC9
USBOTG_DATA6/SPEED	USB OTG data6/Suspend signal; multiplexed with SLCDC1_DAT10 and USBG_TXR_INT_B through PC8
USBOTG_DATA5/RCV	USB OTG data5/RCV signal; multiplexed with SLCDC1_DAT9 through PC7
USBH1_RXDP	USB Host1 Receive Data Plus signal, multiplexed with UART4_RXD; multiplexed with SLCDC1_DAT6 and UART4_RTS_ALT through PB31
USBH1_RXDM	USB Host1 Receive Data Minus signal; multiplexed with SLCDC1_DAT5 and UART4_CTS through PB30
USBH1_TXDP	USB Host1 Transmit Data Plus signal; multiplexed with UART4_CTS, multiplexed with SLCDC1_DAT4 and UART4_RXD_ALT through PB29
USBH1_TXDM	USB Host1 Transmit Data Minus signal; multiplexed with UART4_TXD, multiplexed with SLCDC1_DAT3 through PB28
USBH1_OE_B	USB Host1 Output Enable signal; multiplexed with SLCDC1_DAT2 through PB27
USBH1_FS	USB Host1 Full Speed output signal, multiplexed with UART4_RTS, multiplexed with SLCDC1_DAT1 through PB26
USBH1_RCV	USB Host1 RCV signal; multiplexed with SLCDC1_DAT0 through PB25
USB_OC_B	USB OC signal. PB24
USB_PWR	USB Power signal; PB23
USBH1_SUSP	USB Host1 Suspend signal; PB22
LCD Controller and Smart LCD Controller	
OE_ACD	Alternate Crystal Direction/Output Enable; PA31
CONTRAST	This signal is used to control the LCD bias voltage as contrast control; PA30
VSYNC	Frame Sync or Vsync—This signal also serves as the clock signal output for gate; driver (dedicated signal SPS for Sharp panel HR-TFT); PA29.
HSYNC	Line Pulse or HSync; PA28
SPL_SPR	Sampling start signal for left and right scanning. Through GPIO, this signal is multiplexed with the SLCDC1_CLK; PA27.
PS	Control signal output for source driver (Sharp panel dedicated signal). This signal is multiplexed with the SLCDC1_CS; PA26.
CLS	Start signal output for gate driver. This signal is invert version of PS (Sharp panel dedicated signal). This signal is multiplexed with the SLCDC1_RS; PA25.
REV	Signal for common electrode driving signal preparation (Sharp panel dedicated signal). This signal is multiplexed with SLCDC1_D0; PA24.
LD [17:0]	LCD Data Bus—All LCD signals are driven low after reset and when LCD is off. Through GPIO, LD[15:0] signals are multiplexed with SLCDC1_DAT[15:0], SLCDC. PA23–PA6.
LSCLK	Shift Clock; PA5

Table 3. i.MX27/MX27L Signal Descriptions (continued)

Pad Name	Function/Notes
Note: SLCDC signals are multiplexed with LCDC signals.	
ATA (not available on i.MX27L)	
ATA_DATA15–0	ATA Data Bus, [15:0] are multiplexed with ETMTRACEPKT4–12, FEC_MDIO, ETMTRACEPKT13–14 SD3_D3–0; Through GPIO also are multiplexed with SLCDC 15–0, and FEC signals; PF23, PD16–PD2.
Noisy I/O Supply Pins	
N _{VDD} 1–15, A _{VDD}	Noisy Supply for the I/O pins. There are 16 I/O voltage pads, N _{VDD} 1 through N _{VDD} 15 + A _{VDD} .
Analog Supply Pins	
FPM _{VDD} MPLL _{VDD} OSC26 _{VDD} UPLL _{VDD} OSC32 _{VDD} OSC32VSS	Supply for analog blocks
FPMVSS MPLL _{VSS} OSC26VSS UPLL _{VSS}	Quiet GND for analog blocks
Q_{VDD} Internal Power Supply	
Q _{VDD}	Power supply pins for silicon internal circuitry
QVSS	GND pins for silicon internal circuitry
FUSE _{VDD}	For Fuse _{VDD}
RTC _{VDD}	For RTC, SCC power supply
RTC _{VSS}	For RTC, SCC GND

Table 3. i.MX27/MX27L Signal Descriptions (continued)

Pad Name	Function/Notes
----------	----------------

Note: Both 1-Wire and Fast Ethernet Controller signals are multiplexed with other signals. As a result these signal names do not appear in this list. The signals are listed below with the named signal that they are multiplexed.

1-Wire Signals:

The 1-Wire input and output signal is multiplexed with JTAG RTCK pad, PE16.

Fast Ethernet Controller (FEC) Signals on the i.MX27. The ATA module does not exist on the i.MX27L:

FEC_TX_EN: Transmit enable signal, through GPIO multiplexed with ATA_DATA15 pad; PF23

FEC_TX_ER: Transmit Data Error; through GPIO multiplexed with ATA_DATA14 pad; PD16

FEC_COL: Collision signal; through GPIO multiplexed with ATA_DATA13 pad; PD15

FEC_RX_CLK: Receive Clock signal; through GPIO multiplexed with ATA_DATA12 pad; PD14

FEC_RX_DV: Receive data Valid signal; through GPIO multiplexed with ATA_DATA11 pad; PD13

FEC_RXD0: Receive Data0; through GPIO multiplexed with ATA_DATA10 pad; PD12

FEC_TX_CLK: Transmit Clock signal; through GPIO multiplexed with ATA_DATA9 pad; PD11

FEC_CRFS: Carrier Sense enable; through GPIO multiplexed with ATA_DATA8 pad; PD10

FEC_MDC: Management Data Clock; through GPIO multiplexed with ATA_DATA7 pad; PD9

FEC_MDIO: Management Data Input/Output, multiplexed with ATA_DATA6 pad; PD8

FEC_RXD3-1: Receive Data; through GPIO multiplexed with ATA_DATA5-3 pad; PD7-5

FEC_RX_ER: Receive Data Error; through GPIO multiplexed with ATA_DATA2 pad; PD4

FEC_TXD3-2: Transmit Data; through GPIO multiplexed with ATA_DATA1-0; pad; PD3-2

FEC_TXD1: Transmit Data; through GPIO multiplexed with SD3_CLK pad; PD1

FEC_TXD0: Transmit Data; through GPIO multiplexed with SD3_CMD pad; PD0

Note: The Rest ATA signals are multiplexed with PCMCIA Pads.

3.1 Power-Up Sequence

The i.MX27/MX27L processor consists of three major sets for power supply voltage named Q_{VDD} (core logic supply), $FUSE_{VDD}$ (analog supply for FUSEBOX), and $N_{VDD}, VDDA$ (IO supply). The External Voltage Regulators and power-on devices must provide the applications processor with a specific sequence of power and resets to ensure proper operation.

It is important that the applications processor power supplies be powered-up in a certain order to avoid unintentional fuse blown. Q_{VDD} should be powered up before $FUSE_{VDD}$. The recommended order is:

1. Q_{VDD} (1.5 V)
2. $FUSE_{VDD}$ (1.8 V), N_{VDD} (1.8/2.775 V), and Analog Supplies (2.775 V). See [Table 3](#) for signal descriptions.

or

1. Q_{VDD} (1.5 V), N_{VDD} (1.8/2.775 V), and Analog Supplies (2.775 V). See [Table 3](#) for signal descriptions.
2. $FUSE_{VDD}$ (1.8 V).

3.2 EMI Pins Multiplexing

This section discusses the multiplexing of EMI signals. The EMI signals' multiplexing is done inside the EMI. [Table 4](#) lists the i.MX27 pin names, pad types, and the memory devices' equivalent pin names.

Table 4. EMI Multiplexing

Pin Name	Pad Type	WEIM	SDRAM	PCMCIA	DDR	NFC
A0	regular	A0	MA0	A0	MA0	—
A1	regular	A1	MA1	A1	MA1	—
A2	regular	A2	MA2	A2	MA2	—
A3	regular	A3	MA3	A3	MA3	—
A4	regular	A4	MA4	A4	MA4	—
A5	regular	A5	MA5	A5	MA5	—
A6	regular	A6	MA6	A6	MA6	—
A7	regular	A7	MA7	A7	MA7	—
A8	regular	A8	MA8	A8	MA8	—
A9	regular	A9	MA9	A9	MA9	—
A10	regular	A10	—	A10	—	—
MA10	regular	—	MA10	—	MA10	—
A11	regular	A11	MA11	A11	MA11	—
A12	regular	A12	MA12	A12	MA12	—
A13	regular	A13	MA13	A13	MA13	—
A14	regular	A14	—	A14	—	—
A15	regular	A15	—	A15	—	—
A16	regular	A16	—	A16	—	—
A17	regular	A17	—	A17	—	—
A18	regular	A18	—	A18	—	—
A19	regular	A19	—	A19	—	—
A20	regular	A20	—	A20	—	—
A21	regular	A21	—	A21	—	—
A22	regular	A22	—	A22	—	—
A23	regular	A23	—	A23	—	—
A24	regular	A24	—	A24	—	—
A25	regular	A25	—	A25	—	—
SDBA1	regular	—	SDBA1	$\overline{CE1}$	—	—
SDBA0	regular	—	SDBA0	$\overline{CE2}$	—	—
SD0	ddr	—	SD0	—	—	—
SD1	ddr	—	SD1	—	—	—
SD2	ddr	—	SD2	—	—	—
SD3	ddr	—	SD3	—	—	—
SD4	ddr	—	SD4	—	—	—
SD5	ddr	—	SD5	—	—	—

Table 4. EMI Multiplexing (continued)

Pin Name	Pad Type	WEIM	SDRAM	PCMCIA	DDR	NFC
SD6	ddr	—	SD6	—	—	—
SD7	ddr	—	SD7	—	—	—
SD8	ddr	—	SD8	—	—	—
SD9	ddr	—	SD9	—	—	—
SD10	ddr	—	SD10	—	—	—
SD11	ddr	—	SD11	—	—	—
SD12	ddr	—	SD12	—	—	—
SD13	ddr	—	SD13	—	—	—
SD14	ddr	—	SD14	—	—	—
SD15	ddr	—	SD15	—	—	—
SD16	ddr	—	SD16	—	—	—
SD17	ddr	—	SD17	—	—	—
SD18	ddr	—	SD18	—	—	—
SD19	ddr	—	SD19	—	—	—
SD20	ddr	—	SD20	—	—	—
SD21	ddr	—	SD21	—	—	—
SD22	ddr	—	SD22	—	—	—
SD23	ddr	—	SD23	—	—	—
SD24	ddr	—	SD24	—	—	—
SD25	ddr	—	SD25	—	—	—
SD26	ddr	—	SD26	—	—	—
SD27	ddr	—	SD27	—	—	—
SD28	ddr	—	SD28	—	—	—
SD29	ddr	—	SD29	—	—	—
SD30	ddr	—	SD30	—	—	—
SD31	ddr	—	SD31	—	—	—
DQM0	ddr	—	DQM0	—	—	—
DQM1	ddr	—	DQM1	—	—	—
DQM2	ddr	—	DQM2	—	—	—
DQM3	ddr	—	DQM3	—	—	—
EB0	regular	EB0	—	REG	—	—
EB1	regular	EB1	—	IORD	—	—
OE	regular	OE	—	IOWR	—	—
CS0	regular	CS0	—	—	—	—
CS1	regular	CS1	—	—	—	—

Table 4. EMI Multiplexing (continued)

Pin Name	Pad Type	WEIM	SDRAM	PCMCIA	DDR	NFC
CS2	regular	CS2	CSD0	—	—	—
CS3	regular	CS3	CSD1	—	—	—
CS4	regular	CS4	—	—	—	—
CS5	regular	CS5	—	—	—	—
ECB	regular	ECB	—	—	—	—
LBA	regular	LBA	—	$\overline{\text{OE}}$	—	—
BCLK	regular	BCLK	—	—	—	—
RW	regular	RW	—	WE	—	—
RAS	regular	—	RAS	—	—	—
CAS	regular	—	CAS	—	—	—
SDWE	regular	—	SDWE	—	—	—
SDCKE0	regular	—	SDCKE0	—	—	—
SDCKE1	regular	—	SDCKE1	—	—	—
SDCLK	regular	—	SDCLK	—	—	—
$\overline{\text{SDCLK}}$	—	—	—	—	—	—
SDQS0	ddr	—	—	—	SDQS0	—
SDQS1	ddr	—	—	—	SDQS1	—
SDQS2	ddr	—	—	—	SDQS2	—
SDQS3	ddr	—	—	—	SDQS3	—
$\overline{\text{NFW}}$	regular	—	—	—	—	WE
$\overline{\text{NFR}}$	regular	—	—	—	—	RE
NFALE	regular	—	—	—	—	ALE
NFCLE	regular	—	—	—	—	CLE
$\overline{\text{NFWP}}$	regular	—	—	—	—	WP
$\overline{\text{NFCE}}$	regular	—	—	—	—	CE
NFRB	regular	—	—	—	—	R/B
D15	regular	D15	—	D15	—	D15
D14	regular	D14	—	D14	—	D14
D13	regular	D13	—	D13	—	D13
D12	regular	D12	—	D12	—	D12
D11	regular	D11	—	D11	—	D11
D10	regular	D10	—	D10	—	D10
D9	regular	D9	—	D9	—	D9
D8	regular	D8	—	D8	—	D8
D7	regular	D7	—	D7	—	D7

Table 4. EMI Multiplexing (continued)

Pin Name	Pad Type	WEIM	SDRAM	PCMCIA	DDR	NFC
D6	regular	D6	—	D6	—	D6
D5	regular	D5	—	D5	—	D5
D4	regular	D4	—	D4	—	D4
D3	regular	D3	—	D3	—	D3
D2	regular	D2	—	D2	—	D2
D1	regular	D1	—	D1	—	D1
D0	regular	D0	—	D0	—	D0
$\overline{\text{PC_CD1}}$	regular	—	—	$\overline{\text{CD1}}$	—	—
$\overline{\text{PC_CD2}}$	regular	—	—	$\overline{\text{CD2}}$	—	—
$\overline{\text{PC_WAIT}}$	regular	—	—	$\overline{\text{WAIT}}$	—	—
PC_READY	regular	—	—	READY	—	—
PC_PWRON	regular	—	—	PC_PWRON	—	—
PC_VS1	regular	—	—	VS1	—	—
PC_VS2	regular	—	—	VS2	—	—
PC_BVD1	regular	—	—	BVD1	—	—
PC_BVD2	regular	—	—	BVD2	—	—
PC_RST	regular	—	—	RST	—	—
IOIS16	regular	—	—	IOIS16/WP	—	—
$\overline{\text{PC_RW}}$	regular	—	—	$\overline{\text{RW}}$	—	—
PC_POE	regular	—	—	POE	—	—
M_REQUEST	regular	—	—	—	—	—
M_GRANT	regular	—	—	—	—	—

4 Electrical Characteristics

This section provides the chip-level and module-level electrical characteristics for the i.MX27/i.MX27L.

4.1 i.MX27/i.MX27L Chip-Level Conditions

This section provides the chip-level electrical characteristics for the IC. See [Table 5](#) for a quick reference to the individual tables and sections.

Table 5. i.MX27/i.MX27L Chip-Level Conditions

For these characteristics...	Topic appears...
Table 6, "DC Absolute Maximum Conditions"	on page 40
Table 7, "DC Operating Conditions"	on page 40
Table 9, "Interface Frequency"	on page 41
Table 10, "Frequency Definition for Power Consumption Measurement"	on page 42
Table 11, "Current Consumption"	on page 42
Section 4.1.3, "Test Conditions and Recommended Settings"	on page 43

[Table 6](#) provides the DC absolute maximum operating conditions.

CAUTION

Stresses beyond those listed under [Table 6](#) may cause permanent damage to device. These are stress ratings only. Functional operation of device at these or any other conditions beyond those indicated under "DC operating conditions" is not implied. Exposure to absolute-maximum-rated conditions for extended periods may affect device reliability.

Table 6. DC Absolute Maximum Conditions

Ref. Num	Parameter	Symbol	Min	Max	Units
1	Supply Voltage	V_{DDmax}	-0.5	1.52	V
2	Supply Voltage (Level Shift I/O)	$V_{DDIOmax}$	-0.5	3.3	V
3	Input Voltage Range	V_{Imax}	-0.5	$NV_{DD} (1, 5-13) + 0.3$	V
4	Storage Temperature Range	$T_{storage}$	-20	125	°C

[Table 7](#) provides the DC recommended operating conditions.

Table 7. DC Operating Conditions

ID	Parameter	Symbol	Min	Typical	Max	Units
1	Core Supply Voltage (@266 MHz)	QV_{DD}	1.2	1.3	1.52	V
2	Core Supply Voltage (@400 MHz)	QV_{DD}	1.38	1.45	1.52	V
3	RTC, SCC separate Supply Voltage	RTC_{VDD}	1.2	—	1.52	V

Table 7. DC Operating Conditions (continued)

ID	Parameter	Symbol	Min	Typical	Max	Units
4	I/O Supply Voltage, Fast (7, 11, 12, 14, 15) ¹	NV _{DD_FAST}	1.75	—	2.8	V
5	I/O Supply Voltage, Slow (5, 6, 8, 9, 10, 13, AV _{DD})	NV _{DD_SLOW}	1.75	—	3.05	V
		NV _{DD_SLOW}	1.75	—	3.1	V
6	I/O Supply Voltage, DDR (1, 2, 3, 4) ²	NV _{DD_DDR}	1.75	—	1.9	V
7	Analog Supply Voltage: FPMV _{DD} , UPLL _{VDD} , MPLL _{VDD}	V _{DD}	1.35	1.4	1.6	V
8	Fusebox read Supply Voltage	FUSEV _{DD} (read mode)	1.7	1.875	1.95	V
9	Fusebox Program Supply Voltage	FUSEV _{DD} (program mode)	3.00	3.15	3.30	V
10	OSC32V _{DD}	V _{OSC32}	1.1	—	1.6	V
11	OSC26V _{DD}	V _{OSC26}	2.68	—	2.875	V
12	Operating Ambient Temperature (17mm x17mm package)	T _A	-20	—	85	°C
13	Operating Ambient Temperature (19mm x19mm package)	T _A	-40	—	85	°C

¹ Segments 11, 14, 15 are mixture of Fast and Slow GPIO.

² Segments 1, 3, 4 are mixture of DDR and Fast GPIO.

4.1.1 DPLL Frequency Specification

Table 8 provides the frequency specifications for the DPLL.

Table 8. DPLL FREQUENCY Specifications

Parameter	Min	Typical	Max	Unit
Output Duty Cycle (dpdck)	48.5	50.0	51.5	%
Output Duty Cycle (dpgdck_2)	48.5	50.0	51.5	%
Frequency Lock Time (FOL mode or non-integer MF)	—	—	80	μs
Phase Lock Time	—	—	100	μs
Cycle-to-Cycle Jitter	—	—	0.2	ns
MPLL Operating Frequency ¹	—	—	600	MHz

¹ A 600 MHz MPLL frequency equals 1.2 GHz at the 2x clock port (see figure 3-2 in MCIMX27 reference manual), so by using the DIV3 divider, it results in an Arm clock frequency of 400 MHz.

Table 9 provides information for interface frequency limits.

Table 9. Interface Frequency

ID	Parameter	Symbol	Min	Typical	Max	Units
1	JTAG: TCK Frequency of Operation	f _{JTAG}	DC	5	33.25	MHz

4.1.2 Current Consumption

Table 10 defines the frequency settings used for specifying power consumption in Table 11. All power states are specified. The temperature setting of 25° C is used for specifying the Deep Sleep Mode (DSM) per the temperature range shown in Table 7.

Table 10. Frequency Definition for Power Consumption Measurement

ID	Parameter	Symbol	Value	Units
1	MCU core	$f_{MCUmeas@266}$	266	MHz
2	MCU core	$f_{MCUmeas@400}$	400	MHz
3	MCU AHB bus	$f_{MCU-AHBmeas}$	133	MHz
4	MCU IP bus	$f_{MCU-IPmeas}$	66	MHz
5	OSC32	$f_{osc32khzmeas}$	32.768	kHz

Table 11 shows the power consumption for the i.MX27/i.MX27L device.

Table 11. Current Consumption

ID	Parameter	Conditions	Symbol	Typical	Max	Units
1	RUN Current (QV _{DD} current)	RUN Current at 266 MHz QV _{DD} = 1.3 V, T _A = 25°C	I _{ddRUN}	215	260	mA
		RUN Current at 400 MHz QV _{DD} = 1.45 V, T _A = 25°C	I _{ddRUN}	366	420	mA
2	Doze Current	<ul style="list-style-type: none"> QV_{DD} = 1.2 V NV_{DD} = 1.75 V Arm is in wait for interrupt mode. Arm well bias is enabled. MCU PLL is on. SPLL is off. FPM is on. 26MHz oscillator is on. 32 kHz oscillator is on. Other modules are off. T_A = 25° C. 	I _{ddDOZE}	11	13.5	mA
3	Sleep Current	<ul style="list-style-type: none"> QV_{DD} = 1.2 V. NV_{DD} = 1.75 V. Both PLLs are off. FPM is off. Arm well bias is enabled. 32 kHz oscillator is on. 26MHz oscillator is off. All the modules are off. T_A = 25° C. 	I _{ddSLEEP}	0.9	3.5	mA
4	Power Gate	<ul style="list-style-type: none"> NV_{DD13} is on. See Table 7 for specific values. RTC_{VDD}, OSC32_{VDD} are on. See Table 7 for specific values. All other V_{DD} = 0 V T_A = 25° C. 	I _{ddPG}	50	216	µA

4.1.3 Test Conditions and Recommended Settings

Unless specified, AC timing parameters are specified for 15 pF loading on i.MX27/i.MX27L pads. Drive strength has been kept at default/reset values for testing. EMI timing has been verified with high drive strength setting and 25 pF loads. SDHC timing has also been verified with high drive strength setting. Unless otherwise noted, AC/DC parameters are guaranteed at operating conditions shown in [Table 7](#).

4.2 Module-Level Electrical Specifications

This section contains the i.MX27/i.MX27L electrical information including timing specifications, arranged in alphabetical order by module name.

4.2.1 Pads IO (PADIO) Electricals

4.2.1.1 DC Electrical Characteristics

The over-operating characteristics appear in [Table 12](#) for GPIO pads and [Table 13](#) for DDR (Double Data Rate) pads (unless otherwise noted).

Table 12. GPIO Pads DC Electrical Parameters

Parameter	Symbol	Test Conditions	Min	Typical	Max	Units
High-level output voltage	V_{OH}	$I_{OH} = -1 \text{ mA}$	$N_{VDD} - 0.15$	—	—	V
		$I_{OH} = \text{specified Drive}$	$0.8 * N_{VDD}$	—	—	V
Low-level output voltage	V_{OL}	$I_{OL} = 1 \text{ mA}$	—	—	0.15	V
		$I_{OL} = \text{specified Drive}$	—	—	$0.2 * N_{VDD}$	V
High-level output current, slow slew rate	I_{OH_S}	$V_{OH} = 0.8 * N_{VDD}$ Normal High Max High ¹	-2 -4 -8	—	—	mA
High-level output current, fast slew rate	I_{OH_F}	$V_{OH} = 0.8 * N_{VDD}$ Normal High Max High ¹	-4 -6 -8	—	—	mA
Low-level output current, slow slew rate	I_{OL_S}	$V_{OL} = 0.2 * N_{VDD}$ Normal	2	—	—	mA
		High	4	—	—	
		Max High ¹	8	—	—	
Low-level output current, fast slew rate	I_{OL_F}	$V_{OL} = 0.2 * N_{VDD}$ Normal	4	—	—	mA
		High	6	—	—	
		Max High ¹	8	—	—	
Input Hysteresis	V_{HYS}	Hysteresis enabled	0.25	—	—	V
Schmitt trigger VT+	V_{T+}	Hysteresis enabled	$0.5 * Q_{VDD}$	—	—	V
Schmitt trigger VT-	V_{T-}	Hysteresis enabled	—	—	$0.5 * Q_{VDD}$	V

Electrical Characteristics

Table 12. GPIO Pads DC Electrical Parameters (continued)

Parameter	Symbol	Test Conditions	Min	Typical	Max	Units
Pull-up resistor (22 kΩ PU)	R _{PU}	—	15	22	59	kΩ
Pull-up resistor (47 kΩ PU)	R _{PU}	—	30	47	128	
Pull-up resistor (100 kΩ PU)	R _{PU}	—	34	100	268	
Pull-down resistor (100 kΩ PD)	R _{PD}	—	25	100	343	
Input current (no PU/PD)	I _{IN}	V _I = 0 V _I = N _{VDD}	—	0.33	±1	μA
Input current (22 kΩ PU)	I _{IN}	V _I = 0 V _I = N _{VDD}	—	—	115 0.1	μA μA
Input current (47 kΩ PU)	I _{IN}	V _I = 0 V _I = N _{VDD}	—	—	53 0.1	μA μA
Input current (100 kΩ PU)	I _{IN}	V _I = 0 V _I = N _{VDD}	—	—	25 0.1	μA μA
Input current (100 kΩ PD)	I _{IN}	V _I = 0 V _I = N _{VDD}	—	—	0.25 28	μA μA
Tri-state input leakage current	I _Z	V _I = N _{VDD} or 0 I/O = high Z	—	0.33	±2	μA
High Level DC Input Voltage	V _{IH}	—	0.7*V _{DDIO}	—	V _{DDIO}	V
Low-Level DC Input Voltage	V _{IL}	—	0	—	0.3*V _{DDIO}	V

¹ Maximum High strength should be avoided due to excessive overshoot and ringing.

Table 13. DDR (Double Data Rate) I/O Pads DC Electrical Parameters

Parameter	Symbol	Test Conditions	Min	Typical	Max	Units
High-level output voltage	V _{OH}	I _{OH} = -1 mA	NV _{DD_DDR} -0.08	—	—	V
		I _{OH} = specified Drive	0.8*N _{VDD_} DDR	—	—	V
Low-level output voltage	V _{OL}	I _{OL} = 1 mA	—	—	0.08	V
		I _{OL} = specified Drive	—	—	0.2*N _{VDD_} DDR	V
High-level output current	I _{OH}	V _{OH} =0.8*N _{VDD_DDR} Normal High Max High ¹ DDR Drive ¹	-3.6 -7.2 -10.8 -14.4	—	—	mA
Low-level output current	I _{OL}	V _{OL} =0.2*N _{VDD_DDR} Normal High Max High ¹ DDR Drive ¹	3.6 7.2 10.8 14.4	—	—	mA

Table 13. DDR (Double Data Rate) I/O Pads DC Electrical Parameters (continued)

Parameter	Symbol	Test Conditions	Min	Typical	Max	Units
Low-level input current	I_{IL}	$V_I = 0$	—	1.7	2	μA
High-level input current	I_{IH}	$V_I = NV_{DD_DDR}$	—		2	μA
Tri-state current	I_Z	$V_I = NV_{DD_DDR}$ or 0 I/O = high Z	—	1.7	2	μA

¹ Maximum High and DDR Drive strengths should be avoided due to excessive overshoot and ringing.

4.2.1.2 AC Electrical Characteristics

Figure 2 depicts the load circuit for output pads. Figure 3 depicts the output pad transition time waveform. The range of operating conditions appear in Table 14 for slow general I/O, Table 15 for fast general I/O, and Table 16 for DDR I/O (unless otherwise noted).

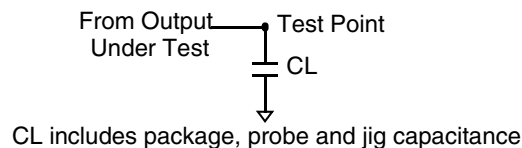
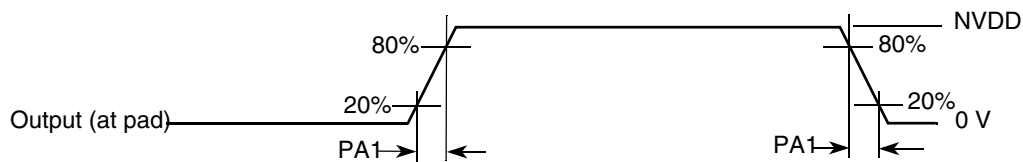
**Figure 2. Load Circuit for Output Pad****Figure 3. Output Pad Transition Time Waveform****Table 14. AC Electrical Characteristics of Slow General I/O Pads**

ID	Parameter	Symbol	Test Condition	Min	Typical	Max	Units
PA1	Output Pad Transition Times (Max High)	tpr	25 pF 50 pF	1.25 1.95	1.9 2.9	3.2 4.75	ns
	Output Pad Transition Times (High)	tpr	25 pF 50 pF	1.45 2.6	—	4.8 8.4	ns
	Output Pad Transition Times (Standard Drive)	tpr	25 pF 50 pF	2.6 5.1	—	8.5 16.5	ns
—	Maximum Input Transition Times ¹	trm	—	—	—	25	ns

¹ Hysteresis mode is recommended for input with transition time greater than 25 ns.

Table 15. AC Electrical Characteristics of Fast General I/O Pads

ID	Parameter	Symbol	Test Condition	Min	Typical	Max	Units
PA1	Output Pad Transition Times (Max High)	tpr	25 pF 50 pF	0.9 1.7	1.2 2.4	2.0 4.0	ns
	Output Pad Transition Times (High)	tpr	25 pF 50 pF	1.15 2.3	1.6 3.1	2.7 5.3	ns
	Output Pad Transition Times (Normal)	tpr	25 pF 50 pF	1.7 3.4	2.4 4.7	4.0 8.0	ns
—	Maximum Input Transition Times ¹	trm	—	—	—	25	ns

¹ Hysteresis mode is recommended for input with transition time greater than 25 ns.

Table 16. AC Electrical Characteristics of DDR I/O Pads

ID	Parameter	Symbol	Test Condition	Min	Typical	Max	Units
PA1	Output Pad Transition Times (DDR Drive)	tpr	25 pF 50 pF	0.5 1.0	0.75 1.45	1.2 2.4	ns
	Output Pad Transition Times (Max High)	tpr	25 pF 50 pF	0.67 1.3	1.0 2.0	1.6 3.1	ns
	Output Pad Transition Times (High)	tpr	25 pF 35 pF	1.0 1.95	1.5 2.9	2.4 4.7	ns
	Output Pad Transition Times (Normal)	tpr	25 pF 50 pF	2.0 3.9	2.9 5.9	4.8 8.4	ns
—	Maximum Input Transition Times	trm	—	—	—	5	ns

4.2.2 1-Wire Electrical Specifications

Figure 4 depicts the RPP timing, and Table 17 lists the RPP timing parameters.

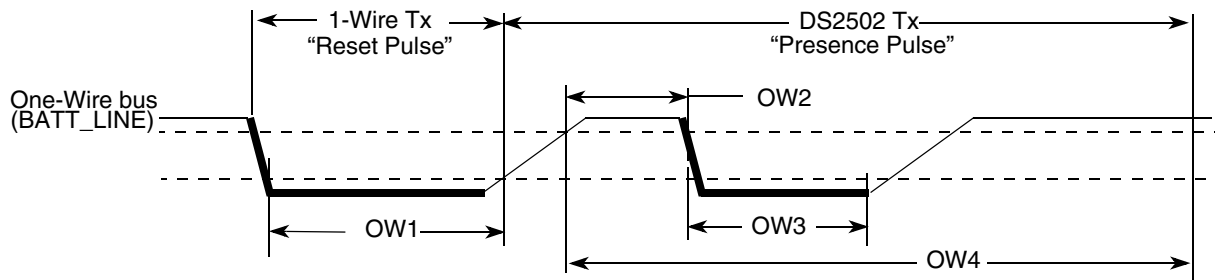

Figure 4. Reset and Presence Pulses (RPP) Timing Diagram

Table 17. RPP Sequence Delay Comparisons Timing Parameters

ID	Parameters	Symbol	Min	Typical	Max	Units
OW1	Reset Time Low	t _{RSTL}	480	511		μs
OW2	Presence Detect High	t _{PDH}	15	—	60	μs

Table 17. RPP Sequence Delay Comparisons Timing Parameters (continued)

ID	Parameters	Symbol	Min	Typical	Max	Units
OW3	Presence Detect Low	t_{PDL}	60	—	240	μs
OW4	Reset Time High	t_{RSTH}	480	512	—	—

Figure 5 depicts Write 0 Sequence timing, and Table 18 lists the timing parameters.

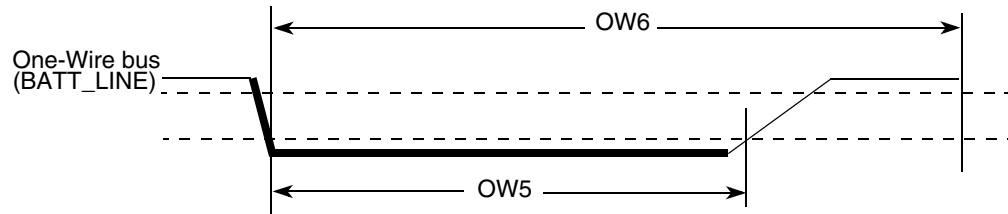

Figure 5. Write 0 Sequence Timing Diagram

Table 18. WR0 Sequence Timing Parameters

ID	Parameter	Symbol	Min	Typical	Max	Units
OW5	Write 0 Low Time	t_{WR0_low}	60	100	120	μs
OW6	Transmission Time Slot	t_{SLOT}	OW5	117	120	μs

Figure 6 depicts Write 1 Sequence timing, Figure 7 depicts the Read Sequence timing, and Table 19 lists the timing parameters.

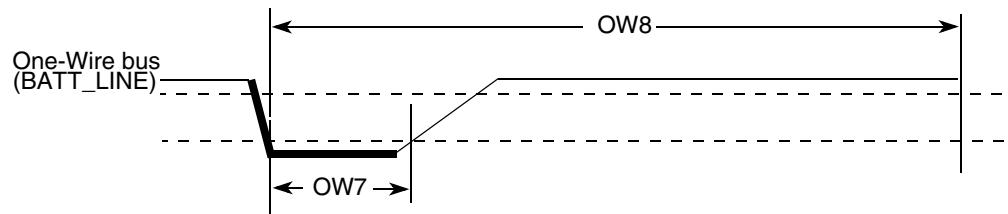

Figure 6. Write 1 Sequence Timing Diagram

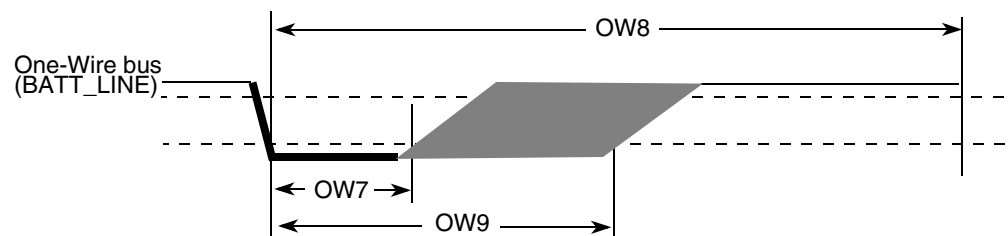

Figure 7. Read Sequence Timing Diagram

Table 19. Write 1/Read Timing Parameters

ID	Parameter	Symbol	Min	Typical	Max	Units
OW7	Write 1/Read Low Time	t_{LOW1}	1	5	15	μs
OW8	Transmission Time Slot	t_{SLOT}	60	117	120	μs
OW9	Release Time	$t_{RELEASE}$	15	—	45	μs

4.2.3 ATA Electrical Specifications

This section describes the electrical information of the Parallel ATA module compliant with ATA/ATAPI-6 specification.

NOTE

The parallel ATA module is not available on the i.MX27L.

Parallel ATA module can work on PIO/Multi-Word DMA/Ultra DMA transfer modes. Each transfer mode has different data transfer rate, Ultra DMA mode 4 data transfer rate is up to 100 MB/s. Parallel ATA module interface consist of a total of 29 pins, Some pins act on different function in different transfer mode. There are different requirements of timing relationships among the function pins conform with ATA/ATAPI-6 specification and these requirements are configurable by the ATA module registers.

Below defines the AC characteristics of all the interface signals on all data transfer modes.

4.2.3.1 General Timing Requirements

Table 20 provides the general timing requirements for the ATA interface signals.

Table 20. AC Characteristics of All Interface Signals

ID	Parameter	Symbol	Min	Max	Unit
S11	Rising edge slew rate for any signal on ATA interface (see note)	S_{rise}	—	1.25	V/ns
S12	Falling edge slew rate for any signal on ATA interface (see note)	S_{fall}	—	1.25	V/ns
S13	Host interface signal capacitance at the host connector	C_{host}	—	20	pF

Note: SRISE and SFALL meets this requirement when measured at the sender's connector from 10–90% of full signal amplitude with all capacitive loads from 15 pf through 40 pf where all signals have the same capacitive load value.

ATA Interface Signals

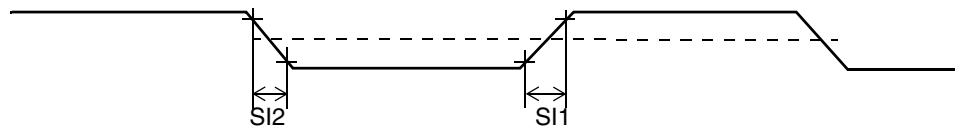

Figure 8. ATA interface Signals Timing Diagram

4.2.4 Digital Audio Mux (AUDMUX)

The AUDMUX provides a programmable interconnect logic for voice, audio and data routing between internal serial interfaces (SSI, SAP) and external serial interfaces (audio and voice codecs). The AC timing of AUDMUX external pins is hence governed by SSI and SAP modules. Please refer to their respective electrical specifications.

4.2.5 CMOS Sensor Interface (CSI)

This section describes the electrical information (AC timing) of the CSI.

4.2.5.1 Gated Clock Mode Timing

VSYNC, HSYNC, and PIXCLK signals are used in this mode. A frame starts with a rising/falling edge on VSYNC, then HSYNC goes high and holds for the entire line. The pixel clock is valid as long as HSYNC is high. [Figure 9](#) and [Figure 10](#) depict the gated clock mode timings of CSI, and [Table 21](#) lists the timing parameters.

Figure 9 shows sensor output data on the pixel clock falling edge. The CSI latches data on the pixel clock rising edge.

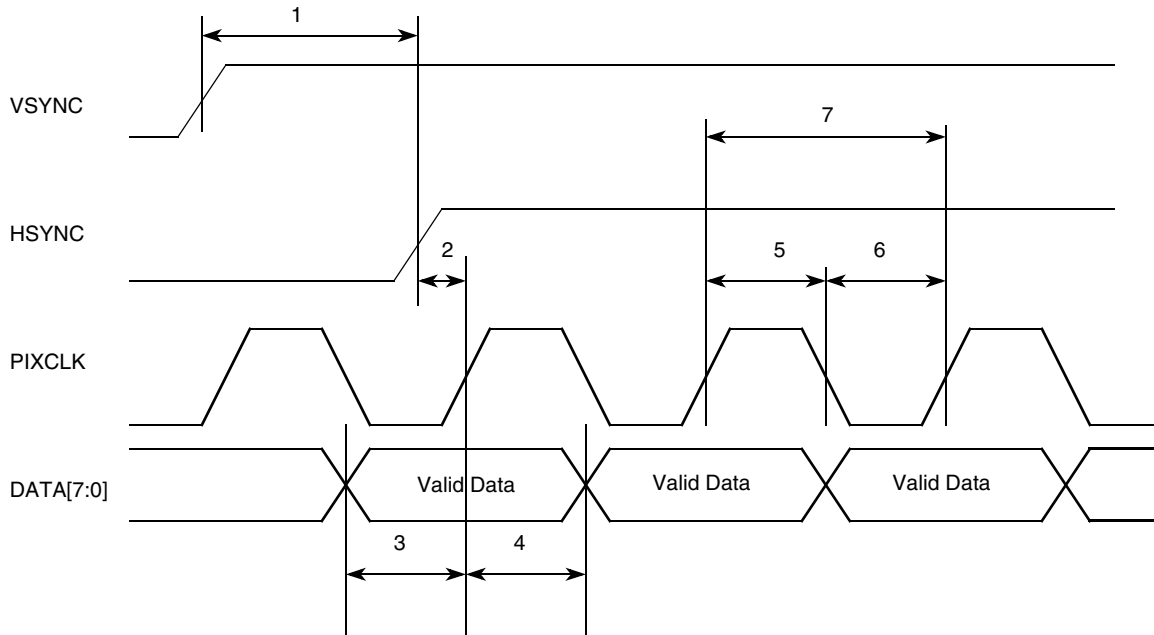

Figure 9. CSI Timing Diagram, Gated, PIXCLK—Sensor Data at Falling Edge, Latch Data at Rising Edge

Figure 10 shows sensor output data on the pixel clock rising edge. The CSI latches data on the pixel clock falling edge.

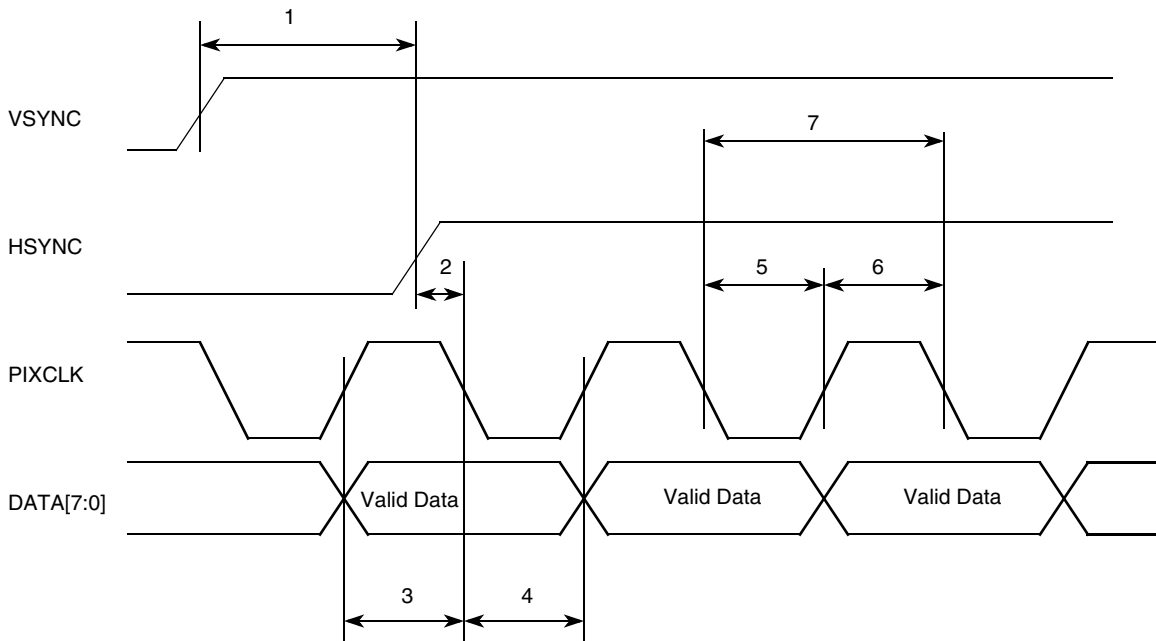

Figure 10. CSI Timing Diagram, Gated, PIXCLK—Sensor Data at Rising Edge, Latch Data at Falling Edge

Table 21. Gated Clock Mode Timing Parameters

Number	Parameter	Minimum	Maximum	Unit
1	csi_vsync to csi_hsync	$9 \cdot T_{HCLK}$	—	ns
2	csi_hsync to csi_pixclk	3	$(T_p/2) - 3$	ns
3	csi_d setup time	1	—	ns
4	csi_d hold time	1	—	ns
5	csi_pixclk high time	T_{HCLK}	—	ns
6	csi_pixclk low time	T_{HCLK}	—	ns
7	csi_pixclk frequency	0	$HCLK/2$	MHz

HCLK = AHB System Clock, THCLK = Period for HCLK, Tp = Period of CSI_PIXCLK

The limitation on pixel clock rise time/fall time is not specified. It should be calculated from the hold time and setup time based on the following assumptions:

Rising-edge latch data:

max rise time allowed = (positive duty cycle—hold time)

max fall time allowed = (negative duty cycle—setup time)

In most of case, duty cycle is 50/50, therefore:

max rise time = (period/2—hold time)

max fall time = (period/2—setup time)

For example: Given pixel clock period = 10 ns, duty cycle = 50/50, hold time = 1 ns, setup time = 1 ns.

positive duty cycle = $10/2 = 5$ ns

max rise time allowed = $5 - 1 = 4$ ns

negative duty cycle = $10/2 = 5$ ns

max fall time allowed = $5 - 1 = 4$ ns

Falling-edge latch data:

max fall time allowed = (negative duty cycle—hold time)

max rise time allowed = (positive duty cycle—setup time)

4.2.5.2 Non-Gated Clock Mode Timing

In non-gated mode only, the VSYNC, and PIXCLK signals are used; the HSYNC signal is ignored.

Figure 11 and Figure 12 show the non-gated clock mode timings of CSI, and Table 22 lists the timing parameters.

Figure 11 shows sensor output data on the pixel clock falling edge. The CSI latches data on the pixel clock rising edge.

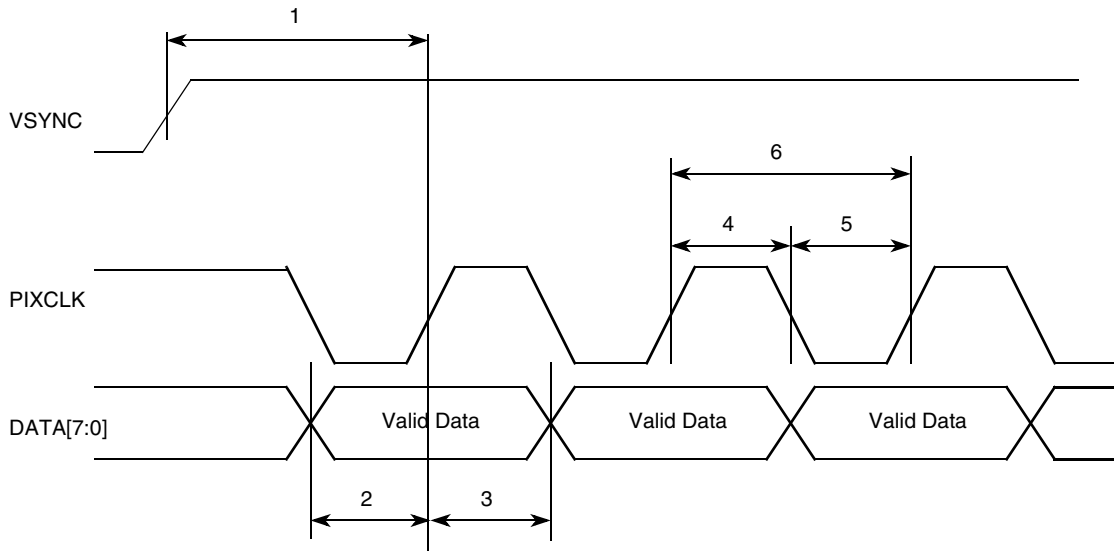

Figure 11. CSI Timing Diagram, Non-Gated, PIXCLK—Sensor Data at Falling Edge, Latch Data at Rising Edge

Figure 12 shows sensor output data on the pixel clock rising edge. The CSI latches data on the pixel clock falling edge.

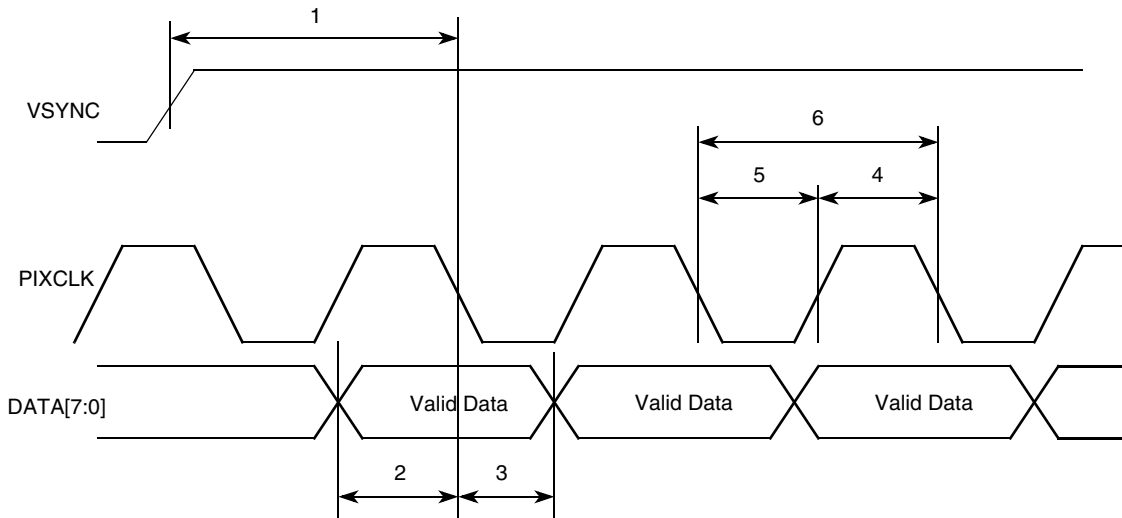

Figure 12. CSI Timing Diagram, Non-Gated, PIXCLK—Sensor Data at Rising Edge, Latch Data at Falling Edge

Table 22. Non-Gated Clock Mode Parameters

Number	Parameter	Minimum	Maximum	Unit
—	csi_vsync to csi_pixclk	$9 \cdot T_{HCLK}$	—	ns
—	csi_d setup time	1	—	ns

Table 22. Non-Gated Clock Mode Parameters (continued)

Number	Parameter	Minimum	Maximum	Unit
—	csi_d hold time	1	—	ns
—	csi_pixclk high time	THCLK	—	ns
—	csi_pixclk low time	THCLK	—	ns
—	csi_pixclk high time	0	HCLK/2	MHz

HCLK = AHB System Clock, THCLK = Period of HCLK

4.3 Timing Diagrams

4.3.1 Configurable Serial Peripheral Interface (CSPI)

This section describes the electrical information of the CSPI.

4.3.1.1 CSPI Timing

Figure 13 and Figure 14 depict the master mode and slave mode timing diagrams of the CSPI and Table 23 lists the timing parameters. The values shown in timing diagrams were tested using a worst case core voltage of 1.1 V, slow pad voltage of 2.68 V, and fast pad voltage of 1.65 V.

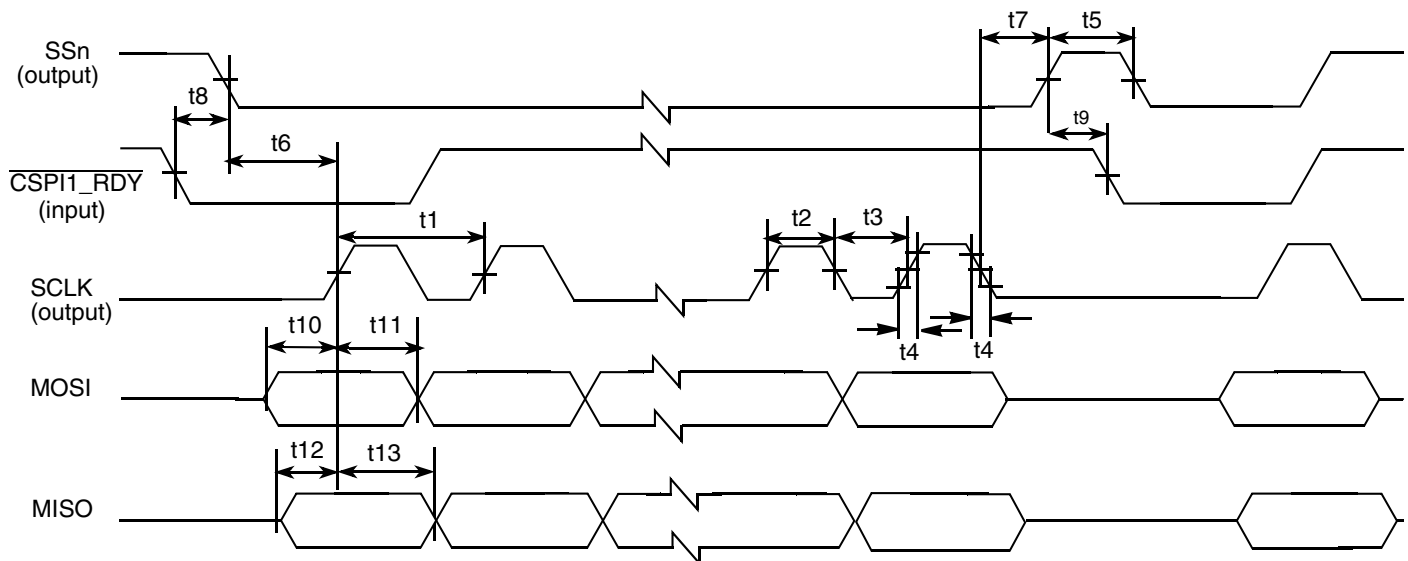

Figure 13. CSPI Master Mode Timing Diagram

Electrical Characteristics

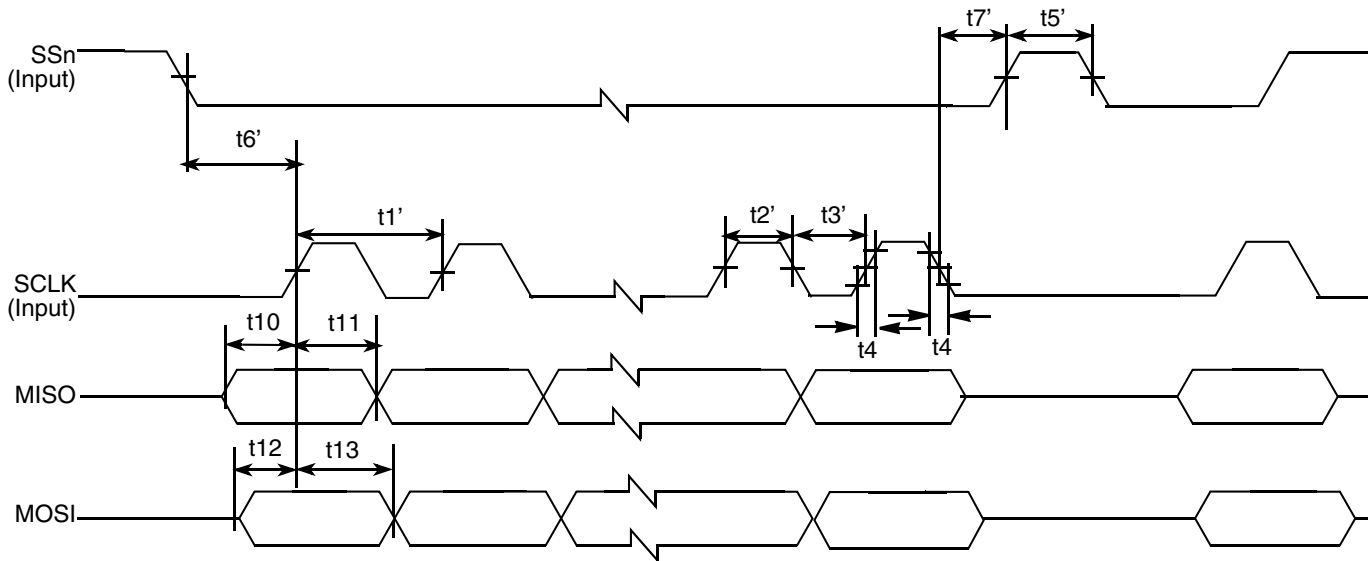

Figure 14. CSPI Slave Mode Timing Diagram

Table 23. CSPI Interface Timing Parameters

ID Num	Parameter Description	Symbol	Minimum	Maximum	Units
t1	CSPI master SCLK cycle time	t_{clko}	45.12	—	ns
t2	CSPI master SCLK high time	t_{clkoH}	22.65	—	ns
t3	CSPI master SCLK low time	t_{clkoL}	22.47	—	ns
t1'	CSPI slave SCLK cycle time	t_{clki}	60.2	—	ns
t2'	CSPI slave SCLK high time	t_{clkiH}	30.1	—	ns
t3'	CSPI slave SCLK low time	t_{clkiL}	30.1	—	ns
t4	CSPI SCLK transition time	t_{pr}^1	2.6	8.5	ns
t5	SSn output pulse width	t_{WssO}	$2T_{sclk}^2 + T_{wait}^3$	—	—
t5'	SSn input pulse width	t_{Wssi}	T_{per}^4	—	—
t6	SSn output asserted to first SCLK edge (SS output setup time)	t_{SssO}	$3T_{sclk}$	—	—
t6'	SSn input asserted to first SCLK edge (SS input setup time)	t_{Sssi}	$T_{per} + 20 \text{ ns}$	—	—
t7	CSPI master: Last SCLK edge to SSn deasserted (SS output hold time)	t_{HssO}	$2T_{sclk}$	—	—
t7'	CSPI slave: Last SCLK edge to SSn deasserted (SS input hold time)	t_{Hssi}	30	—	ns
t8	CSPI master: CSPI1_RDY low to SSn asserted (CSPI1_RDY setup time)	t_{Srdy}	$2T_{per}$	$5T_{per}$	—
t9	CSPI master: SSn deasserted to CSPI1_RDY low	t_{Hrdy}	0	—	ns

Table 23. CSPI Interface Timing Parameters (continued)

ID Num	Parameter Description	Symbol	Minimum	Maximum	Units
t10	Output data setup time	t_{Sdatao}	$(t_{clkOL} \text{ or } t_{clkOH} \text{ or } t_{clkiL} \text{ or } t_{clkiH}) - T_{ipg}$	—	—
t11	Output data hold time	t_{Hdatao}	$t_{clkOL} \text{ or } t_{clkOH} \text{ or } t_{clkiL} \text{ or } t_{clkiH}$	—	—
t12	Input data setup time	t_{Sdatai}	$T_{ipg} + 0.5$	—	ns
t13	Input data hold time	t_{Hdatai}	5	—	ns

¹ The output SCLK transition time is tested with 25 pF drive.

² T_{sclk} = CSPI clock period.

³ T_{wait} = Wait time as per the Sample Period Control Register value.

⁴ T_{per} = CSPI reference baud rate clock period (PERCLK2).

⁵ T_{ipg} = CSPI main clock IPG_CLOCK period.

4.3.2 Direct Memory Access Controller (DMAC)

After assertion of External DMA Request the DMA burst will start when the corresponding DMA channel becomes the current highest priority channel. The External DMA Request should be kept asserted until it is serviced by the DMAC. One External request will initiate at least one DMA burst.

The output External Grant signal from the DMAC is an active-low signal. This signal will be asserted during the time when a DMA burst is ongoing for an External DMA Request, when the following conditions are true:

- The DMA channel for which the DMA burst is ongoing has requested source as external DMA Request (as per RSSR settings).
- REN and CEN bit of this channel are set.
- External DMA Request is asserted.

Once the grant is asserted the External DMA Request will not be sampled until completion of the DMA burst. The priority of the external request will become low, for the next consecutive burst, if another DMA request signal is asserted.

The waveforms are shown for the worst case—that is, smallest burst (1 byte read/write). Minimum and maximum timings for the External request and External grant signal are present in the data sheet.

Figure 15 shows the minimum time for which the External Grant signal remains asserted if External DMA request is de-asserted immediately after sensing grant signal active.

Electrical Characteristics

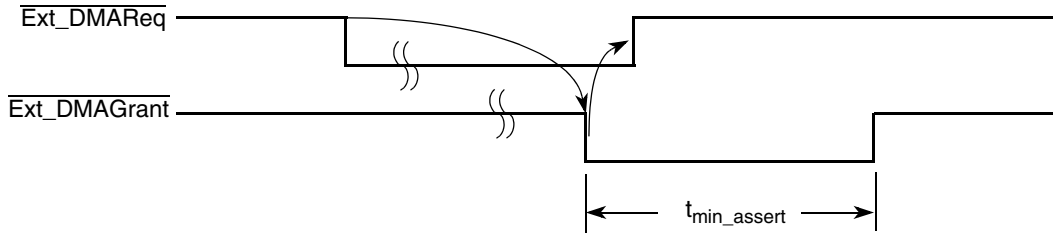
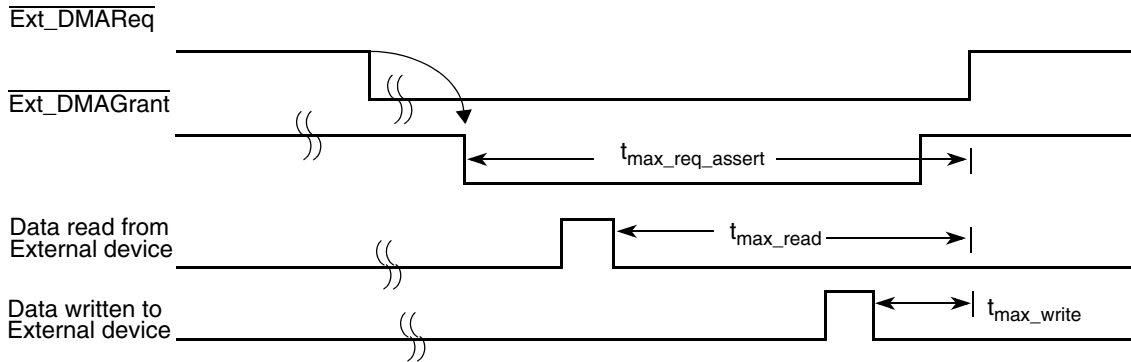

Figure 15. Assertion of DMA External Grant Signal

Figure 16 shows the safe maximum time for which External DMA request can be kept asserted, after sensing grant signal active such that a new burst is not initiated.



NOTE: Assuming worst case that the data is read/written from/to external device as per the above waveform.

Figure 16. Timing Diagram of Safe Maximums for External Request De-Assertion

Table 24. DMAC Timing Parameters

Parameter	Description	3.0 V		1.8 V		Unit
		WCS	BCS	WCS	BCS	
T _{min_assert}	Minimum assertion time of External Grant signal	8hclk+8.6	8hclk+2.74	8hclk+7.17	8hclk+3.25	ns
T _{max_req_assert}	Maximum External Request assertion time after assertion of Grant signal	9hclk-20.66	9hclk-6.7	9hclk-17.96	9hclk-8.16	ns
T _{max_read}	Maximum External Request assertion time after first read completion	8hclk-6.21	8hclk-0.77	8hclk-5.84	8hclk-0.66	ns
T _{max_write}	Maximum External Request assertion time after first write completion	3hclk-5.87	3hclk-8.83	3hclk-15.9	3hclkv91.2	ns

4.3.3 Fast Ethernet Controller (FEC)

This section describes the AC timing specifications of the FEC. The MII signals are compatible with transceivers operating at a voltage of 3.3 V.

4.3.3.1 MII Receive Signal Timing (FEC_RXD[3:0], FEC_RX_DV, FEC_RX_ER, and FEC_RX_CLK)

The receiver functions correctly up to a FEC_RX_CLK maximum frequency of 25 MHz + 1%. There is no minimum frequency requirement. In addition, the FEC IPG clock frequency must exceed twice the FEC_RX_CLK frequency.

Figure 17 shows the MII receive signal timings, and Table 25 lists the timing parameters.

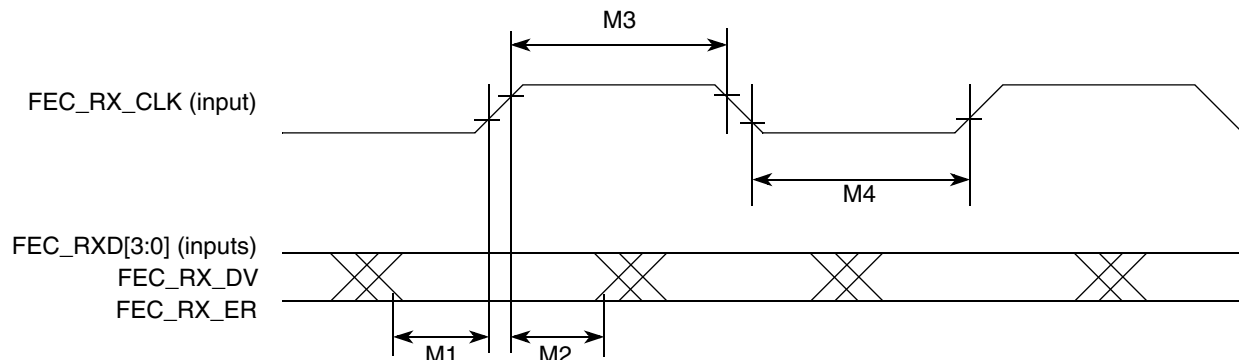

Figure 17. MII Receive Signal Timing Diagram

Table 25. MII Receive Signal Timing Parameters

ID	Parameter ¹	Min	Max	Unit
M1	FEC_RXD[3:0], FEC_RX_DV, FEC_RX_ER to FEC_RX_CLK setup	5	—	ns
M2	FEC_RX_CLK to FEC_RXD[3:0], FEC_RX_DV, FEC_RX_ER hold	5	—	ns
M3	FEC_RX_CLK pulse width high	35%	65%	FEC_RX_CLK period
M4	FEC_RX_CLK pulse width low	35%	65%	FEC_RX_CLK period

¹ FEC_RX_DV, FEC_RX_CLK, and FEC_RXD0 have the same timing in 10 Mbps 7-wire interface mode.

4.3.3.2 MII Transmit Signal Timing (FEC_TXD[3:0], FEC_TX_EN, FEC_TX_ER, and FEC_TX_CLK)

The transmitter functions correctly up to a FEC_TX_CLK maximum frequency of 25 MHz + 1%. There is no minimum frequency requirement. In addition, the FEC IPG clock frequency must exceed twice the FEC_TX_CLK frequency.

Figure 18 shows the MII transmit signal timings, and Table 26 lists the timing parameters.

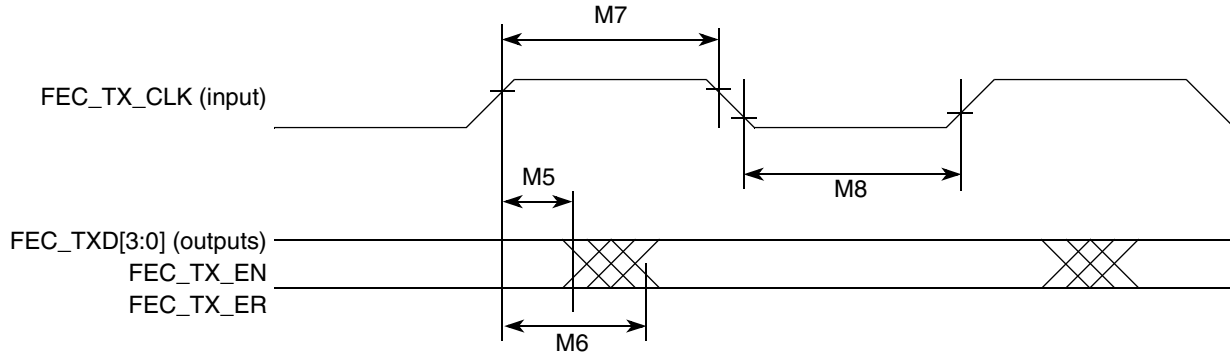

Figure 18. MII Transmit Signal Timing Diagram

Table 26. MII Transmit Signal Timing Parameters

ID	Parameter ¹	Min	Max	Unit
M5	FEC_TX_CLK to FEC_TXD[3:0], FEC_TX_EN, FEC_TX_ER invalid	5	—	ns
M6	FEC_TX_CLK to FEC_TXD[3:0], FEC_TX_EN, FEC_TX_ER valid	—	20	ns
M7	FEC_TX_CLK pulse width high	35%	65%	FEC_TX_CLK period
M8	FEC_TX_CLK pulse width low	35%	65%	FEC_TX_CLK period

¹ FEC_TX_EN, FEC_TX_CLK, and FEC_TXD0 have the same timing in 10 Mbps 7-wire interface mode.

4.3.3.3 MII Asynchronous Inputs Signal Timing (FEC_CRIS and FEC_COL)

Figure 19 shows the MII asynchronous input timings, and Table 27 lists the timing parameters.

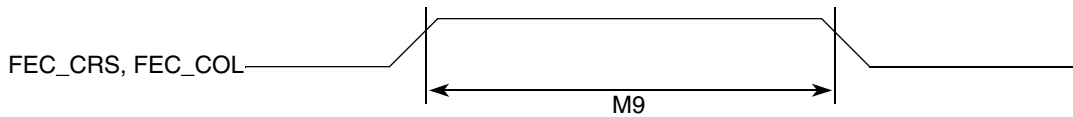

Figure 19. MII Asynchronous Inputs Signal Timing Diagram

Table 27. MII Asynchronous Inputs Signal Timing Parameter

ID	Parameter	Min	Max	Unit
M9 ¹	FEC_CRIS to FEC_COL minimum pulse width	1.5	—	FEC_TX_CLK period

¹ FEC_COL has the same timing in 10 Mbit 7-wire interface mode.

4.3.3.4 MII Serial Management Channel Timing (FEC_MDIO and FEC_MDC)

The FEC functions correctly with a maximum MDC frequency of 2.5 MHz. The MDC frequency should be equal to or less than 2.5 MHz to be compliant with IEEE 802.3 MII specification. However the FEC can function correctly with a maximum MDC frequency of 15 MHz.

Figure 20 shows the MII serial management channel timings, and Table 28 lists the timing parameters.

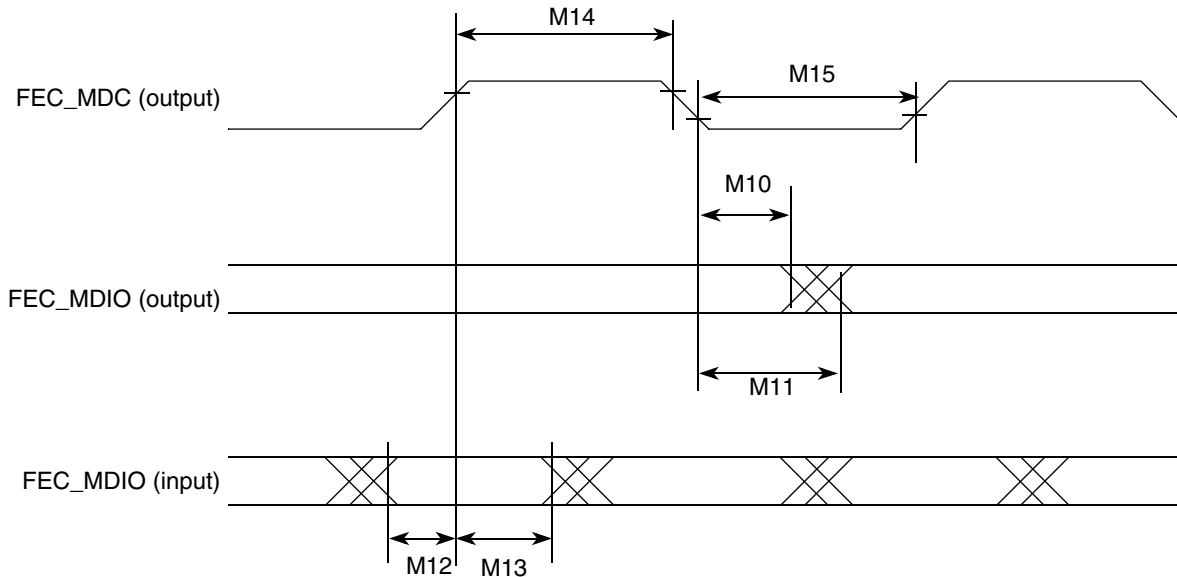

Figure 20. MII Serial Management Channel Timing Diagram

Table 28. MII Serial Management Channel Timing Parameters

ID	Parameter	Min	Max	Unit
M10	FEC_MDC falling edge to FEC_MDIO output invalid (minimum propagation delay)	0	—	ns
M11	FEC_MDC falling edge to FEC_MDIO output valid (max propagation delay)	—	5	ns
M12	FEC_MDIO (input) to FEC_MDC rising edge setup	18	—	ns
M13	FEC_MDIO (input) to FEC_MDC rising edge hold	0	—	ns
M14	FEC_MDC pulse width high	40%	60%	FEC_MDC period
M15	FEC_MDC pulse width low	40%	60%	FEC_MDC period

4.3.4 Inter IC Communication (I²C)

This section describes the electrical information of the I²C module.

4.3.4.1 I²C Module Timing

The I²C communication protocol consists of seven elements: START, Data Source/Recipient, Data Direction, Slave Acknowledge, Data, Data Acknowledge, and STOP. [Figure 21](#) shows the timing of the I²C module. [Table 29](#) lists the I²C module timing parameters.

Electrical Characteristics

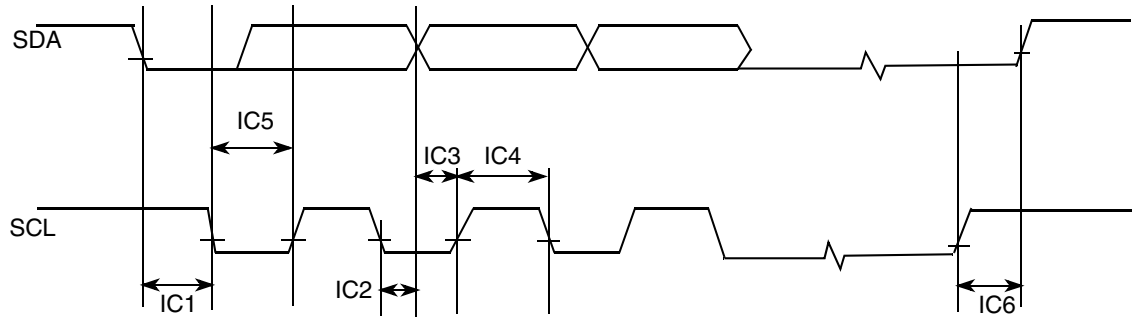

Figure 21. I²C Bus Timing Diagram

Table 29. I²C Module Timing Parameters

ID	Parameter	1.8 V \pm 0.10 V		3.0 V \pm 0.30 V		Unit
		Min	Max	Min	Max	
—	SCL Clock Frequency	0	100	0	100	kHz
IC1	Hold time (repeated) START Condition	114.8	—	111.1	—	ns
IC2	Data Hold Time	0	69.7	0	72.3	ns
IC3	Data Setup Time	3.1	—	1.76	—	ns
IC4	HIGH period of the SCL clock	69.7	—	68.3	—	ns
IC5	LOW period of the SCL clock	336.4	—	335.1	—	ns
IC6	Setup Time for STOP condition	110.5	—	111.1	—	ns

4.3.5 JTAG Controller (JTAGC)

This section details the electrical characteristics for the JTAGC module. [Figure 22](#) shows the JTAGC test clock input timing; [Figure 23](#) shows the JTAGC boundary scan timing; [Figure 24](#) shows the JTAGC test access port; [Figure 25](#) shows the JTAGC TRST timing; and [Table 30](#) lists the JTAGC timing parameters.

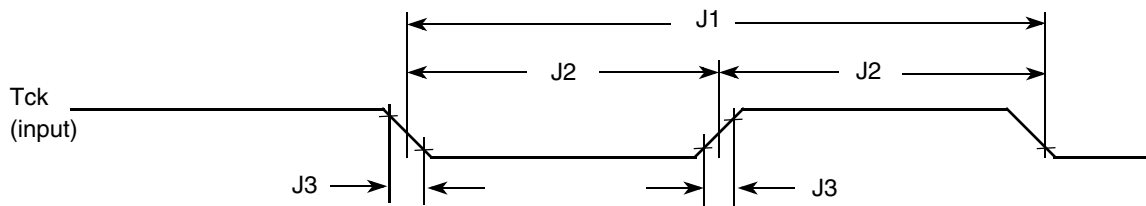

Figure 22. Test Clock Input Timing Diagram

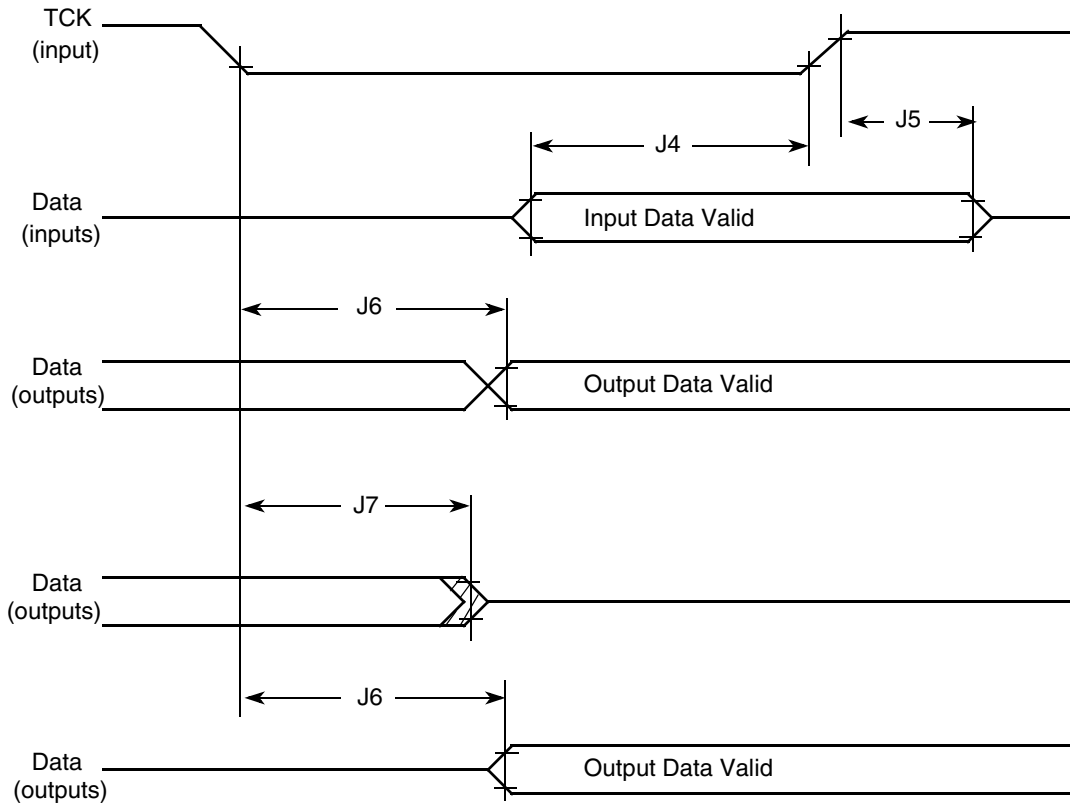

Figure 23. Boundary Scan Timing Diagram

Electrical Characteristics

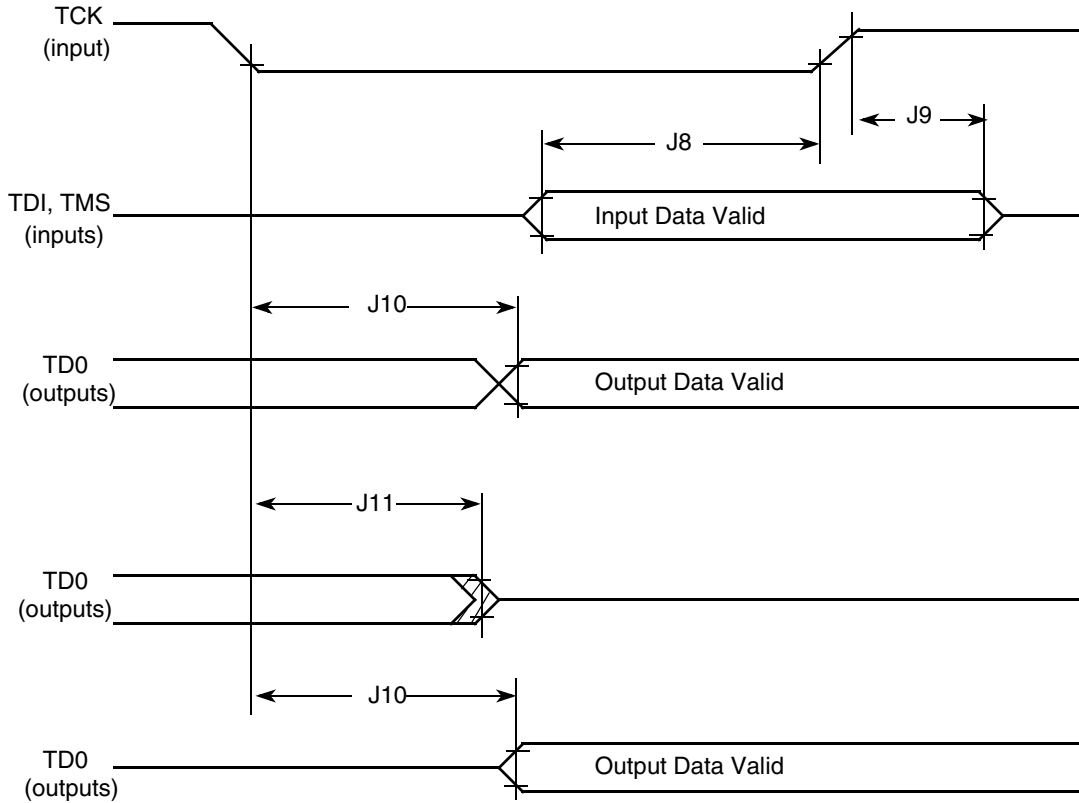

Figure 24. Test Access Port (TAP) Diagram

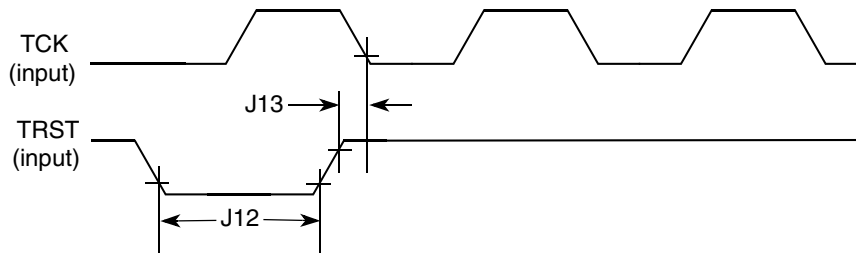

Figure 25. TRST Timing Diagram

Table 30. JTAGC Timing Parameters

ID	Parameter	All Frequencies		Unit
		Min	Max	
J1	TCK cycle time in crystal mode	30.08	—	ns
J2	TCK clock pulse width measured at VM ¹	15.04	—	ns
J3	TCK rise and fall times	—	2.0	ns
J4	Boundary scan input data set-up time	3.5	—	ns
J5	Boundary scan input data hold time	16.0	—	ns

Table 30. JTAGC Timing Parameters (continued)

ID	Parameter	All Frequencies		Unit
		Min	Max	
J6	TCK low to output data valid	—	25.0	ns
J7	TCK low to output high impedance	—	25.0	ns
J8	TMS, TDI data set-up time	3.5	—	ns
J9	TMS, TDI data hold time	20.0	—	ns
J10	TCK low to TDO data valid	—	29.0	ns
J11	TCK low to TDO high impedance	—	29.0	ns
J12	TRST assert time	70.0	—	ns
J13	TRST set-up time to TCK low	2.5.0	—	ns

¹ Midpoint voltage

4.3.6 Liquid Crystal Display Controller Module (LCDC)

Figure 26 and Figure 27 depict the timings of the LCDC, and Table 31 and Table 32 list the timing parameters.

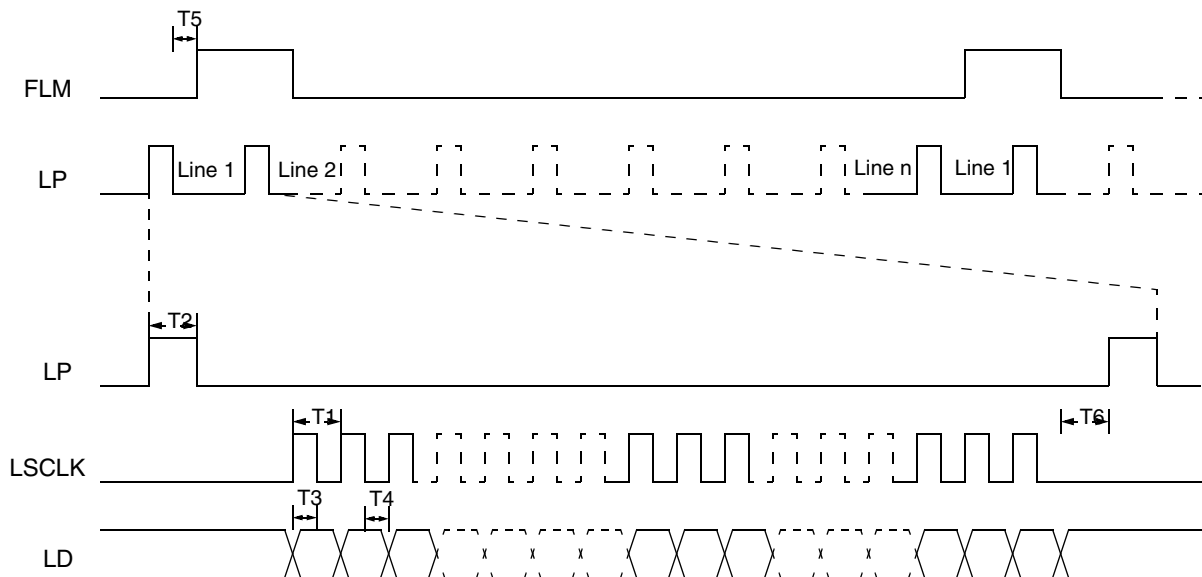

Figure 26. LCDC Non-TFT Mode Timing Diagram

Table 31. LCDC Non-TFT Mode Timing Parameters

ID	Description	Min	Max	Unit
T1	Pixel Clock period	22.5	1000	ns
T2	LP width	1	—	T ¹

Table 31. LCDC Non-TFT Mode Timing Parameters (continued)

ID	Description	Min	Max	Unit
T3	LD setup time	5	—	ns
T4	LD hold time	5	—	ns
T5	Wait between LP and FLM rising edge	2	—	T ¹
T6	Wait between last data and LP rising edge	1	—	T ¹

¹ T is pixel clock period.

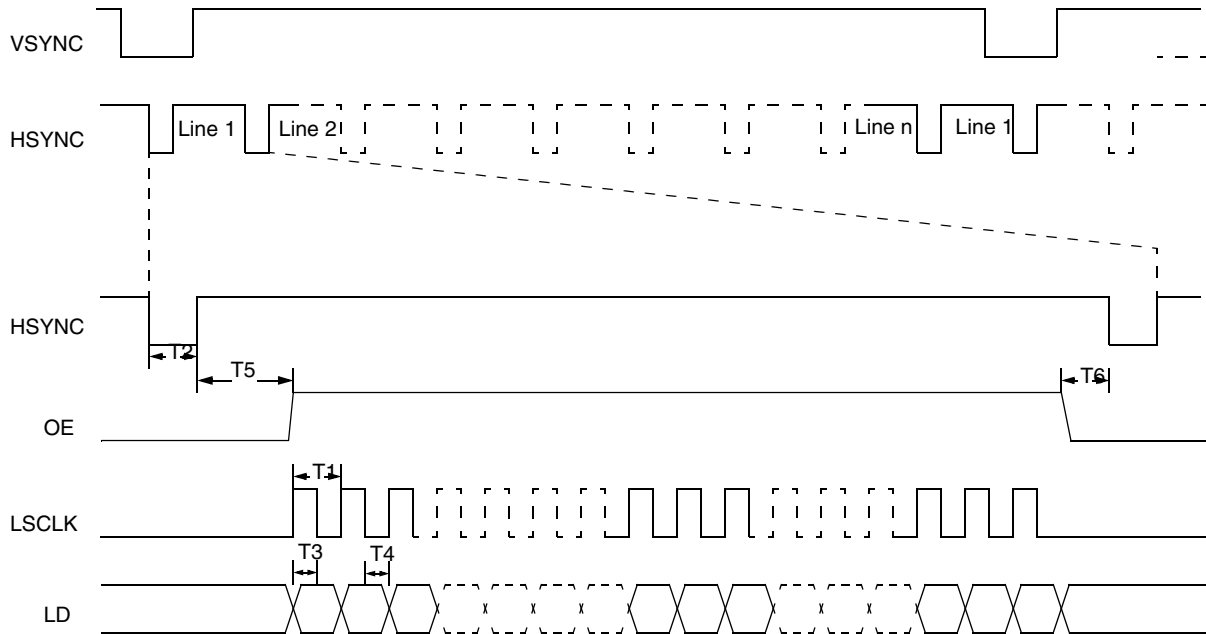

Figure 27. LCDC TFT Mode Timing Diagram

Table 32. LCDC TFT Mode Timing Parameters

ID	Description	Min	Max	Unit
T1	Pixel Clock period	22.5	1000	ns
T2	HSYNC width	1	—	T ¹
T3	LD setup time	5	—	ns
T4	LD hold time	5	—	ns
T5	Delay from the end of HSYNC to the beginning of the OE pulse.	3	—	T ¹
T6	Delay from end of OE to the beginning of the HSYNC pulse.	1	—	T ¹

¹ T is pixel clock period.

4.3.7 Memory Stick Host Controller (MSHC)

Figure 28, Figure 29, and Figure 30, show the MSHC timings. Table 33 and Table 34 list the timing parameters.

NOTE

The i.MX27L does not contain an MSHC module.

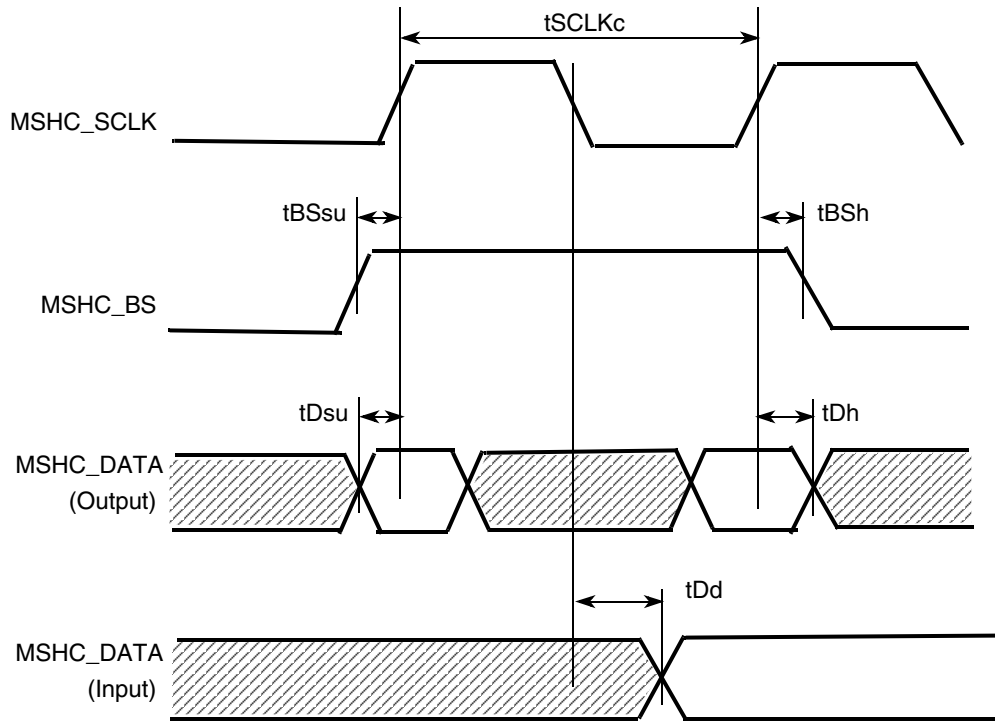

Figure 28. Transfer Operation Timing Diagram (Serial)

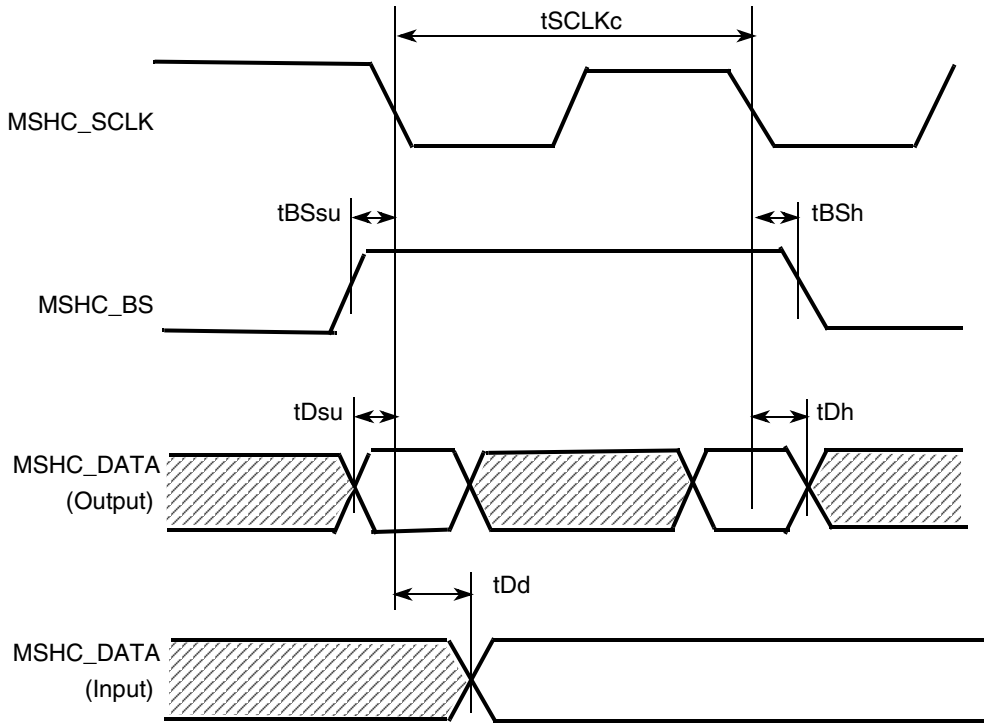

Figure 29. Transfer Operation Timing Diagram (Parallel)

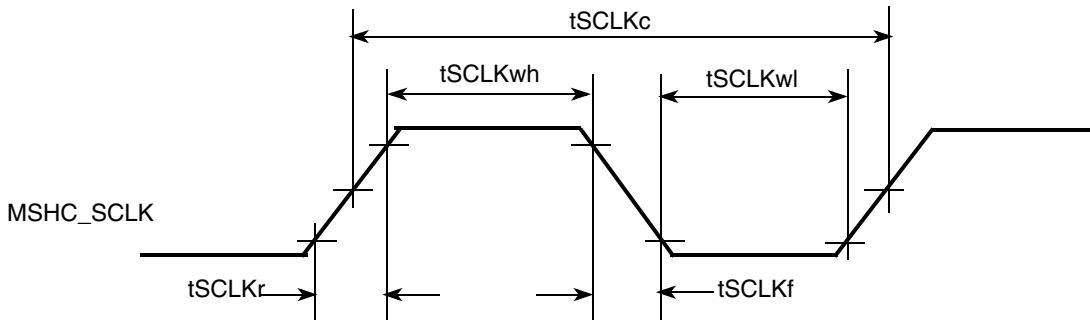

Figure 30. MSHC_CLK Timing Diagram

Table 33. Serial Interface Timing Parameters

Signal	Parameter	Symbol	Standards		Unit
			Min	Max	
MSHC_SCLK	Cycle	tSCLKc	50	—	ns
	H pulse length	tSCLKwh	15	—	ns
	L pulse length	tSCLKwl	15	—	ns
	Rise time	tSCLKr	—	10	ns
	Fall time	tSCLKf	—	10	ns

Table 33. Serial Interface Timing Parameters (continued)

Signal	Parameter	Symbol	Standards		Unit
			Min	Max	
MSHC_BS	Setup time	tBSsu	5	—	ns
	Hold time	tBSh	5	—	ns
MSHC_DATA	Setup time	tDsu	5	—	ns
	Hold time	tDh	5	—	ns
	Output delay time	tDd	—	15	ns

Table 34. Parallel Interface Timing Parameters

Signal	Parameter	Symbol	Standards		Unit
			Min	Max	
MSHC_SCLK	Cycle	tSCLKc	25	—	ns
	H pulse length	tSCLKwh	5	—	ns
	L pulse length	tSCLKwl	5	—	ns
	Rise time	tSCLKr	—	10	ns
	Fall time	tSCLKf	—	10	ns
MSHC_BS	Setup time	tBSsu	8	—	ns
	Hold time	tBSh	1	—	ns
MSHC_DATA	Setup time	tDsu	8	—	ns
	Hold time	tDh	1	—	ns
	Output delay time	tDd	—	15	ns

4.3.8 NAND Flash Controller Interface (NFC)

Figure 31, Figure 32, Figure 33, and Figure 34 show the relative timing requirements among different signals of the NFC at module level, and Table 35 lists the timing parameters. The NAND Flash Controller (NFC) timing parameters are based on the internal NFC clock generated by the Clock Controller module, where time T is the period of the NFC clock in ns. The relationship between the NFC clock and the external timing parameters of the NFC is provided in Table 35.

Table 35 also provides two examples of external timing parameters with NFC clock frequencies of 22.17 MHz and 33.25 MHz. Assuming a 266 MHz FCLK (CPU clock), NFCDIV should be set to divide-by-12 to generate a 22.17 MHz NFC clock and divide-by-8 to generate a 33.25 MHz NFC clock. The user should compare the parameters of the selected NAND Flash memory with the NFC external timing parameters to determine the proper NFC clock. The maximum NFC clock allowed is 66 MHz. It should also be noted that the default NFC clock on power up is 16.63 MHz.

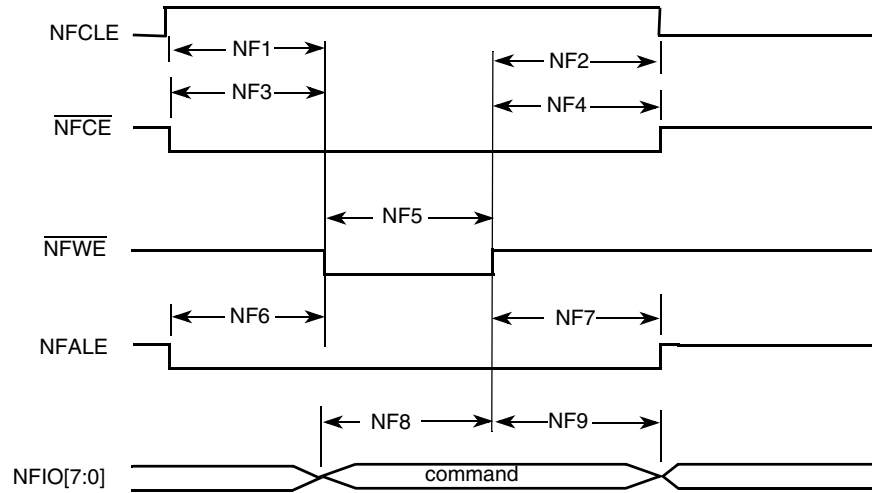

Figure 31. Command Latch Cycle Timing Diagram

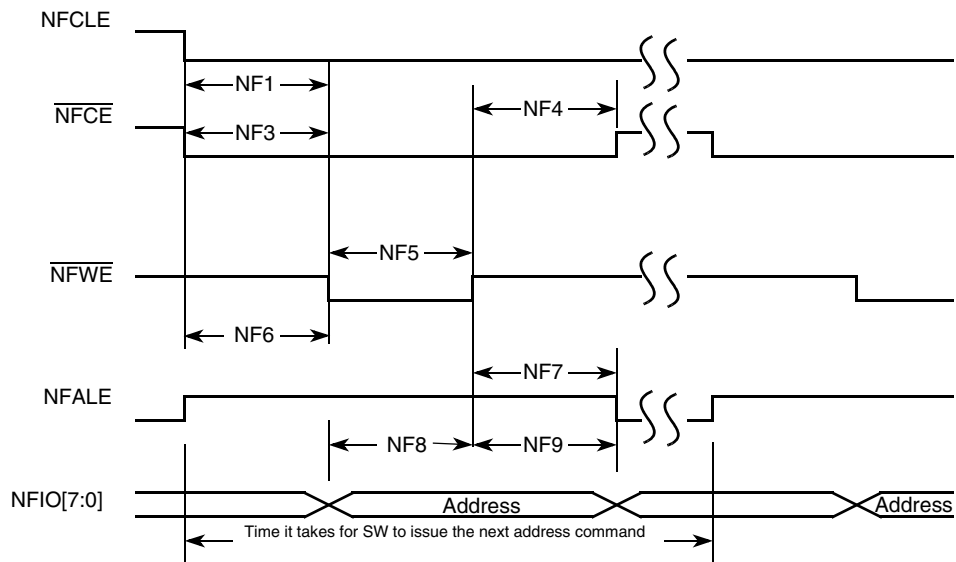

Figure 32. Address Latch Cycle Timing Diagram

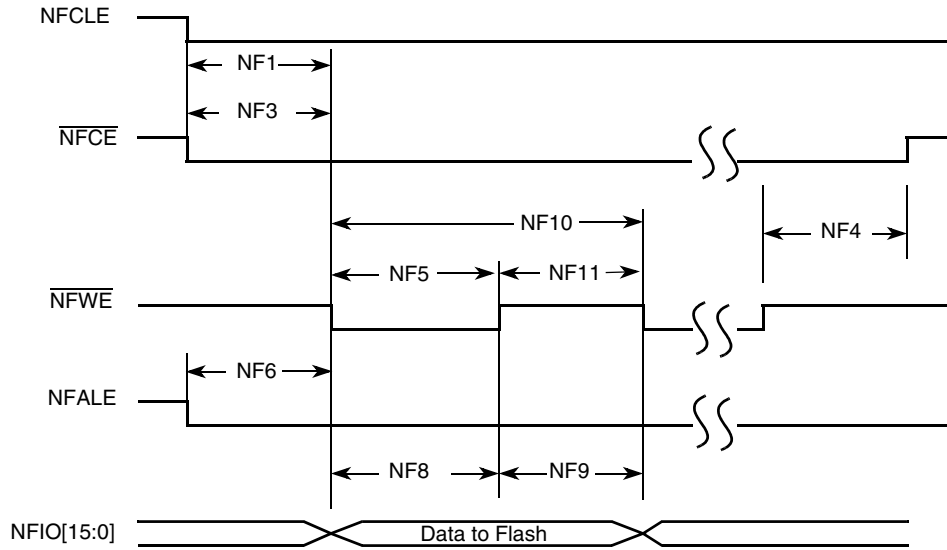

Figure 33. Write Data Latch Timing Diagram

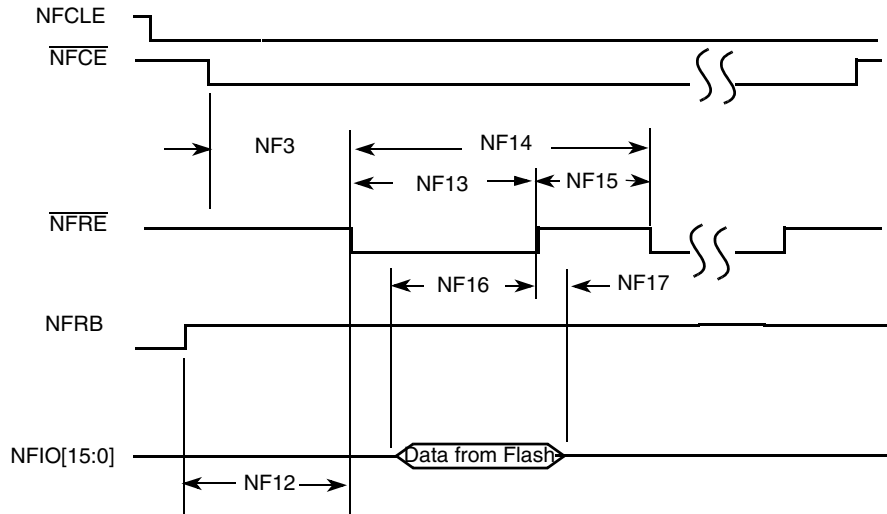

Figure 34. Read Data Latch Timing Diagram

Table 35. NFC Target Timing Parameters

ID	Parameter	Symbol	Relationship to NFC clock period (T)		NFC clock 22.17 MHz T = 45 ns		NFC clock 33.25 MHz T = 30 ns		Unit
			Min	Max	Min	Max	Min	Max	
NF1	NFCLE Setup Time	tCLS	T	—	45	—	30	—	ns
NF2	NFCLE Hold Time	tCLH	T	—	45	—	30	—	ns
NF3	$\overline{\text{NFCE}}$ Setup Time	tCS	T	—	45	—	30	—	ns
NF4	$\overline{\text{NFCE}}$ Hold Time	tCH	T	—	45	—	30	—	ns
NF5	$\overline{\text{NF_WP}}$ Pulse Width	tWP	T	—	45	—	30	—	ns

Table 35. NFC Target Timing Parameters (continued)

ID	Parameter	Symbol	Relationship to NFC clock period (T)		NFC clock 22.17 MHz T = 45 ns		NFC clock 33.25 MHz T = 30 ns		Unit
			Min	Max	Min	Max	Min	Max	
NF6	NFALE Setup Time	tALS	T	—	45	—	30	—	ns
NF7	NFALE Hold Time	tALH	T	—	45	—	30	—	ns
NF8	Data Setup Time	tDS	T	—	45	—	30	—	ns
NF9	Data Hold Time	tDH	T	—	45	—	30	—	ns
NF10	Write Cycle Time	tWC	2T	—	90	—	60	—	ns
NF11	$\overline{\text{NFW}}\overline{\text{E}}$ Hold Time	tWH	T	—	45	—	30	—	ns
NF12	Ready to $\overline{\text{NFR}}\overline{\text{E}}$ Low	tRR	4T	—	180	—	120	—	ns
NF13	$\overline{\text{NFR}}\overline{\text{E}}$ Pulse Width	tRP	1.5T	—	67.5	—	45	—	ns
NF14	READ Cycle Time	tRC	2T	—	90	—	60	—	ns
NF15	$\overline{\text{NFR}}\overline{\text{E}}$ High Hold Time	tREH	0.5T	—	22.5	—	15	—	ns
NF16	Data Setup on READ	tDSR	15	—	15	—	15	—	ns
NF17	Data Hold on READ	tDHR	0	—	0	—	0	—	ns

NOTE

High is defined as 80% of signal value and low is defined as 20% of signal value. All timings are listed according to this NFC clock frequency (multiples of NFC clock period) except NF16, which is not NFC clock related.

The read data is generated by the NAND Flash device and sampled with the internal NFC clock.

4.3.9 Personal Computer Memory Card International Association (PCMCIA)

Figure 35 and Figure 36 show the timings pertaining to the PCMCIA module, each of which is an example of one clock of strobe setup time and one clock of strobe hold time. Table 36 lists the timing parameters.

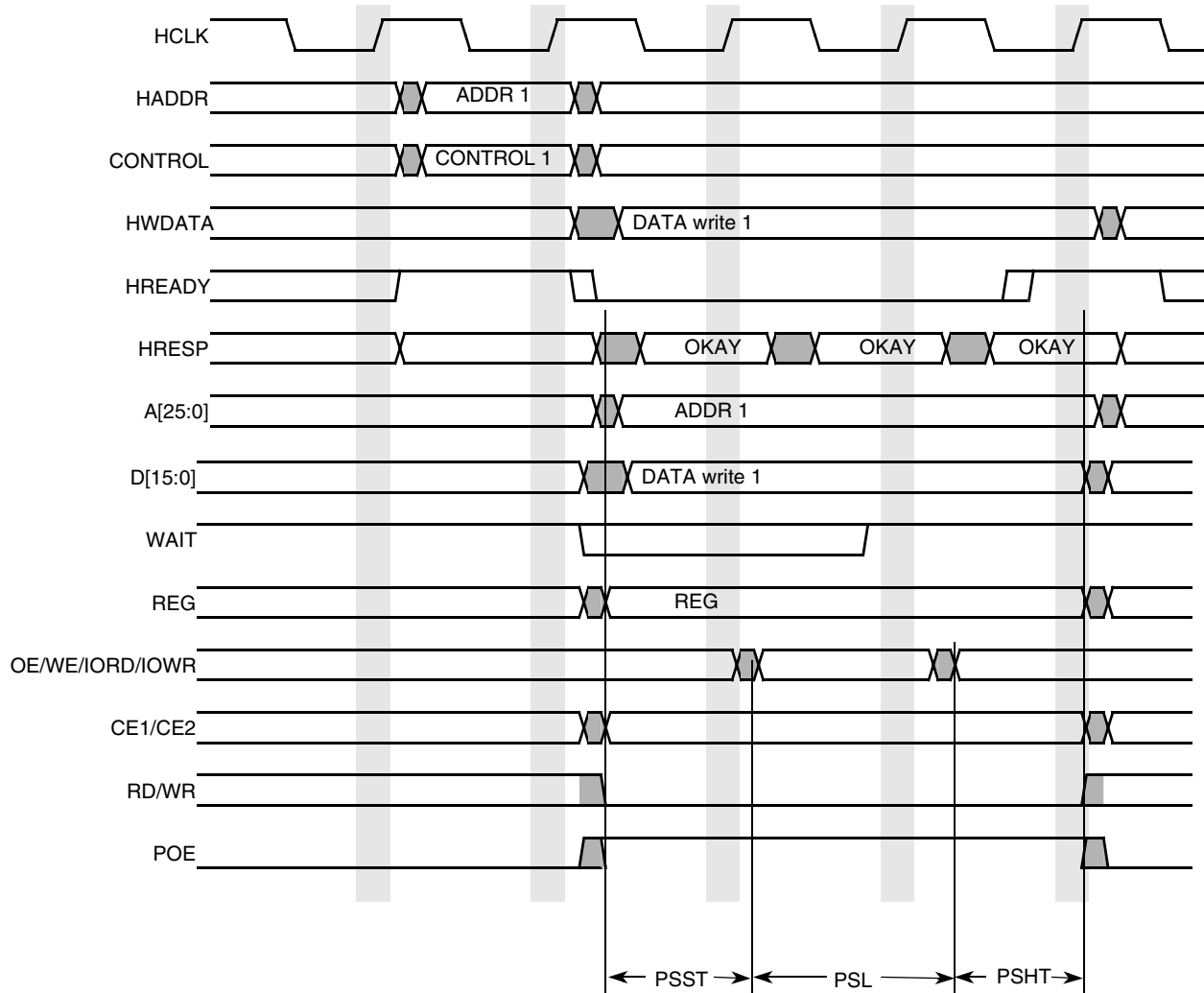

Figure 35. Write Accesses Timing Diagram—PSHT=1, PSST=1

Electrical Characteristics

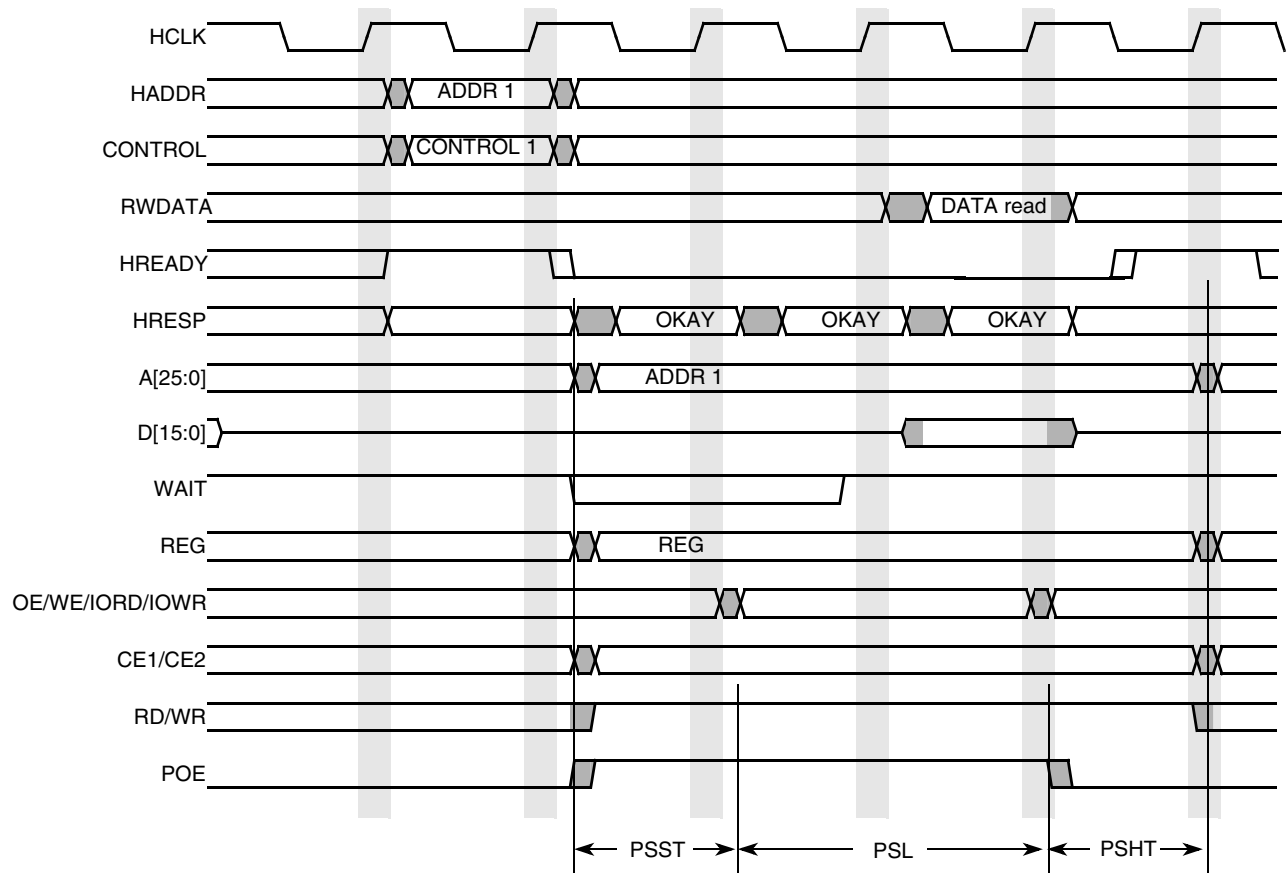

Figure 36. Read Accesses Timing Diagram—PSHT=1, PSST=1

Table 36. PCMCIA Write and Read Timing Parameters

Symbol	Parameter	Min	Max	Unit
PSHT	PCMCIA strobe hold time	0	63	clock
PSST	PCMCIA strobe set up time	1	63	clock
PSL	PCMCIA strobe length	1	128	clock

4.3.10 SDRAM (DDR and SDR) Memory Controller

Figure 37, Figure 38, Figure 39, Figure 40, Figure 41, and Figure 42 depict the timings pertaining to the ESDCTL module, which interfaces Mobile DDR or SDR SDRAM. Table 37, Table 38, Table 39, Table 40, Table 41, and Table 42 list the timing parameters.

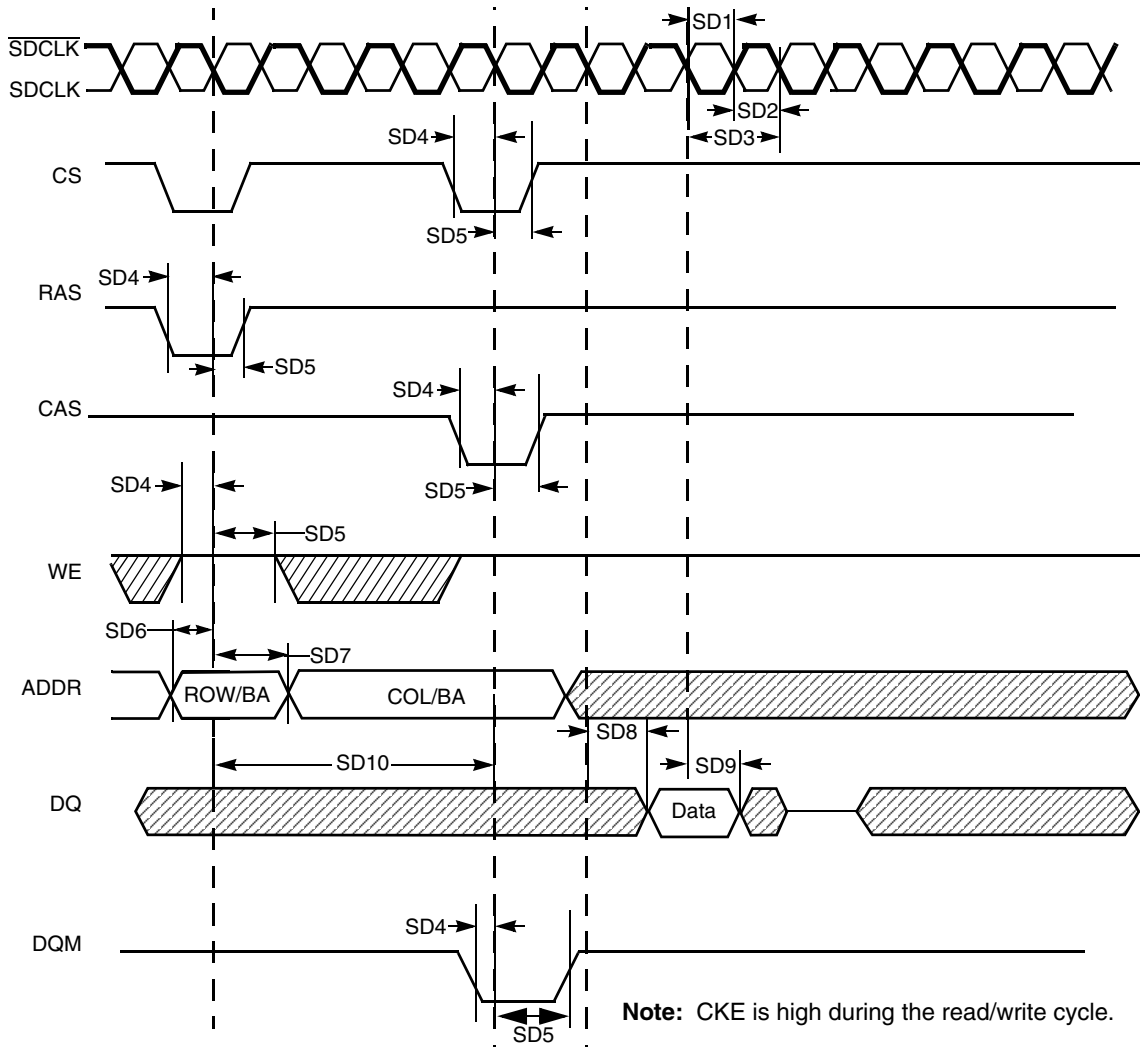

Figure 37. SDRAM Read Cycle Timing Diagram

Table 37. DDR/SDR SDRAM Read Cycle Timing Parameters

ID	Parameter	Symbol	Min	Max	Unit
SD1	SDRAM clock high-level width	tCH	3.4	4.1	ns
SD2	SDRAM clock low-level width	tCL	3.4	4.1	ns
SD3	SDRAM clock cycle time	tCK	7.5	—	ns
SD4	CS, RAS, CAS, WE, DQM, CKE setup time	tCMS	2.0	—	ns
SD5	CS, RAS, CAS, WE, DQM, CKE hold time	tCMH	1.8	—	ns

Table 37. DDR/SDR SDRAM Read Cycle Timing Parameters (continued)

ID	Parameter	Symbol	Min	Max	Unit
SD6	Address setup time	tAS	2.0	—	ns
SD7	Address hold time	tAH	1.8	—	ns
SD8	SDRAM access time	tAC	—	6.47	ns
SD9	Data out hold time ¹	tOH	1.8	—	ns
SD10	Active to read/write command period	tRC	10	—	clock

¹ Timing parameters are relevant only to SDR SDRAM. For the specific DDR SDRAM data related timing parameters, see [Table 41](#) and [Table 42](#).

NOTE

SDR SDRAM CLK parameters are being measured from the 50% point—that is, high is defined as 50% of signal value and low is defined as 50% of signal value. SD1 + SD2 does not exceed 7.5 ns for 133 MHz.

The timing parameters are similar to the ones used in SDRAM data sheets—that is, [Table 37](#) indicates SDRAM requirements. All output signals are driven by the ESDCTL at the negative edge of SDCLK and the parameters are measured at maximum memory frequency.

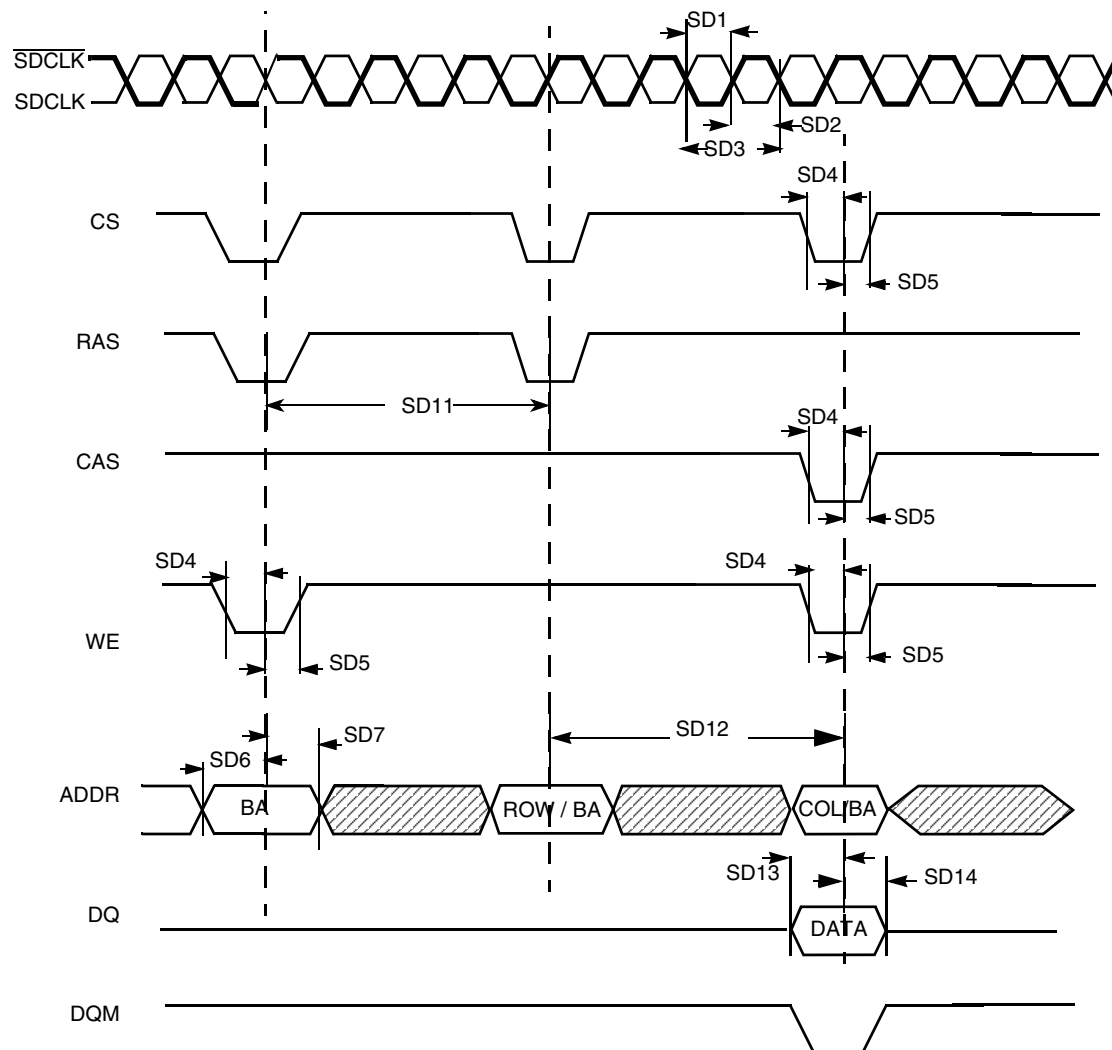

Figure 38. SDR SDRAM Write Cycle Timing Diagram

Table 38. SDR SDRAM Write Timing Parameters

ID	Parameter	Symbol	Min	Max	Unit
SD1	SDRAM clock high-level width	t _{CH}	3.4	4.1	ns
SD2	SDRAM clock low-level width	t _{CL}	3.4	4.1	ns
SD3	SDRAM clock cycle time	t _{CK}	7.5	—	ns
SD4	CS, RAS, CAS, WE, DQM, CKE setup time	t _{CMS}	2.0	—	ns
SD5	CS, RAS, CAS, WE, DQM, CKE hold time	t _{CMH}	1.8	—	ns
SD6	Address setup time	t _{AS}	2.0	—	ns
SD7	Address hold time	t _{AH}	1.8	—	ns
SD11	Precharge cycle period ¹	t _{RP}	1	4	clock
SD12	Active to read/write command ¹	t _{RCD}	1	8	clock

Table 38. SDR SDRAM Write Timing Parameters (continued)

ID	Parameter	Symbol	Min	Max	Unit
SD13	Data setup time	t _{DS}	2.0	—	ns
SD14	Data hold time	t _{DH}	1.3	—	ns

¹ SD11 and SD12 are determined by SDRAM controller register settings.

NOTE

SDR SDRAM CLK parameters are being measured from the 50% point—that is, high is defined as 50% of signal value and low is defined as 50% of signal value.

The timing parameters are similar to the ones used in SDRAM data sheets—that is, Table 38 indicates SDRAM requirements. All output signals are driven by the ESDCTL at the negative edge of SDCLK and the parameters are measured at maximum memory frequency.

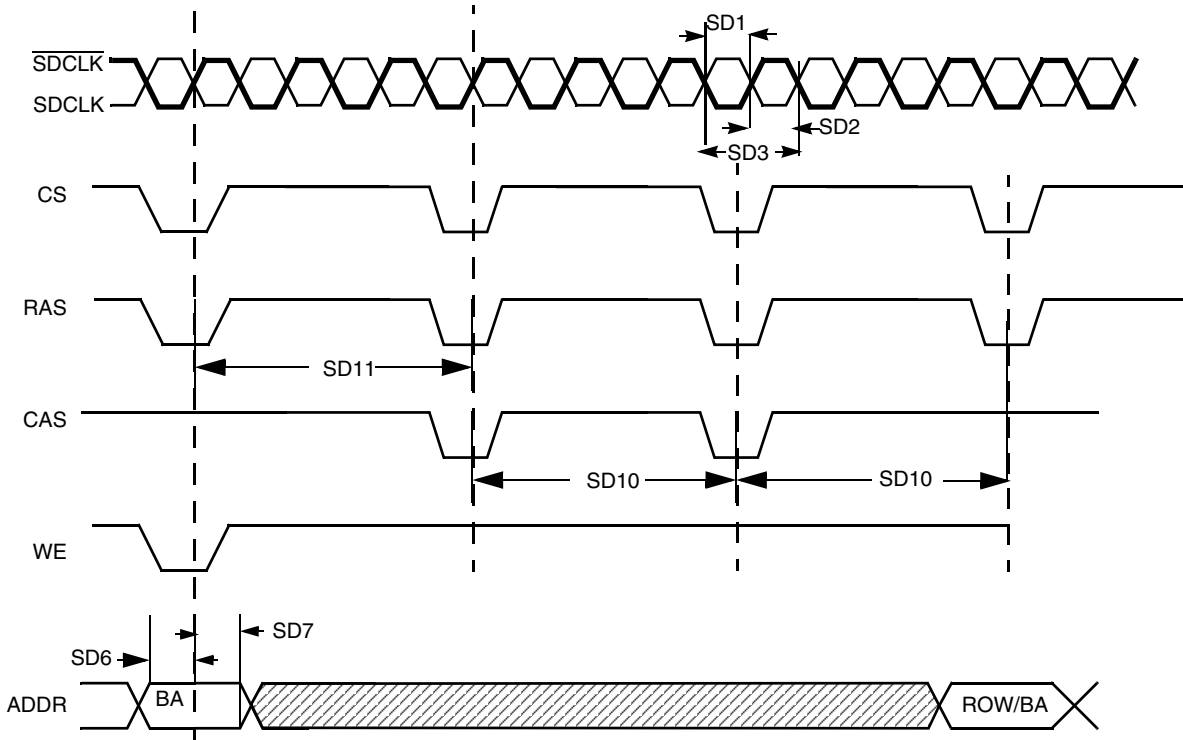

Figure 39. SDRAM Refresh Timing Diagram

Table 39. SDRAM Refresh Timing Parameters

ID	Parameter	Symbol	Min	Max	Unit
SD1	SDRAM clock high-level width	t _{CH}	3.4	4.1	ns
SD2	SDRAM clock low-level width	t _{CL}	3.4	4.1	ns
SD3	SDRAM clock cycle time	t _{CK}	7.5	—	ns

Table 39. SDRAM Refresh Timing Parameters (continued)

ID	Parameter	Symbol	Min	Max	Unit
SD6	Address setup time	tAS	1.8	—	ns
SD7	Address hold time	tAH	1.8	—	ns
SD10	Precharge cycle period ¹	tRP	1	4	clock
SD11	Auto precharge command period ¹	tRC	2	20	clock

¹ SD10 and SD11 are determined by SDRAM controller register settings.

NOTE

SDR SDRAM CLK parameters are being measured from the 50% point—that is, high is defined as 50% of signal value and low is defined as 50% of signal value.

The timing parameters are similar to the ones used in SDRAM data sheets—that is, Table 39 indicates SDRAM requirements. All output signals are driven by the ESDCTL at the negative edge of SDCLK and the parameters are measured at maximum memory frequency.

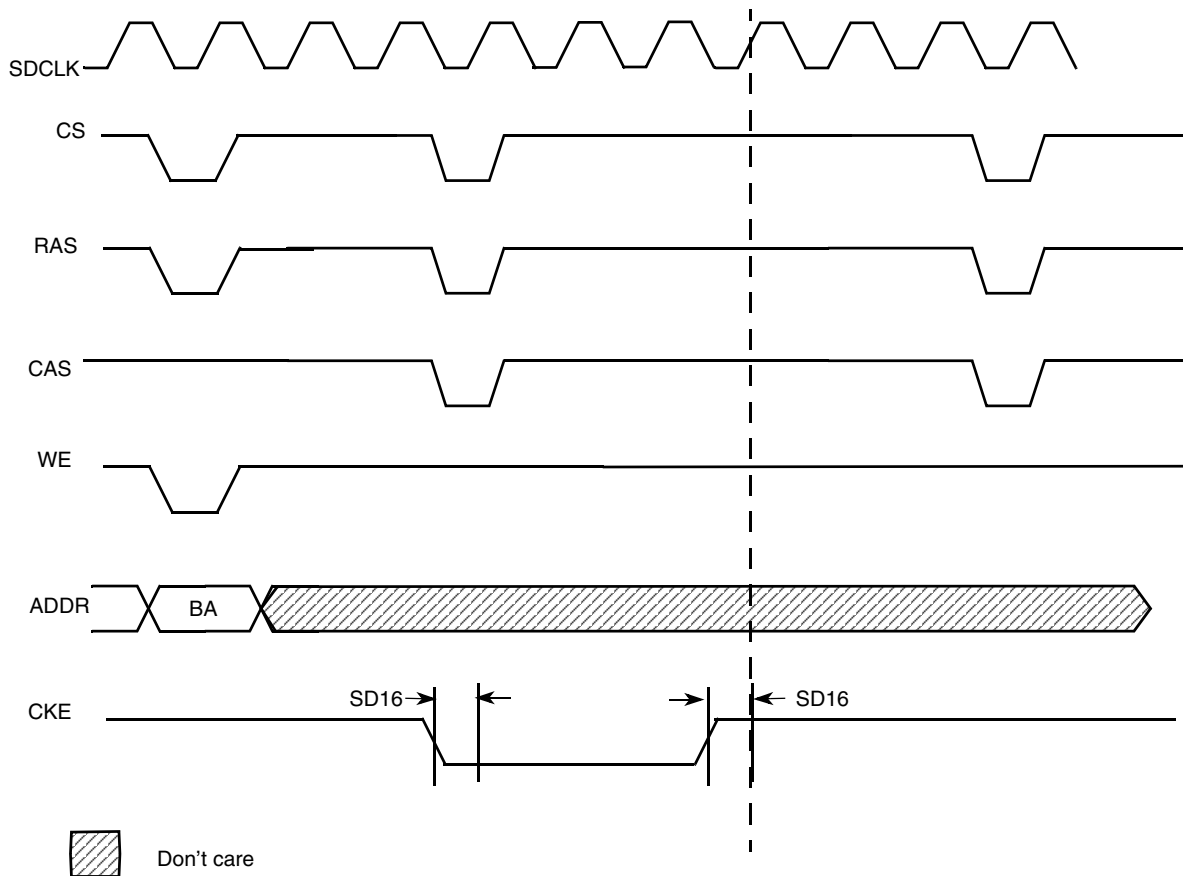

Figure 40. SDRAM Self-Refresh Cycle Timing Diagram

NOTE

The clock continues to run unless both CKEs are low. Then the clock is stopped in low state.

Table 40. SDRAM Self-Refresh Cycle Timing Parameters

ID	Parameter	Symbol	Min	Max	Unit
SD16	CKE output delay time	tCKS	1.8	—	ns

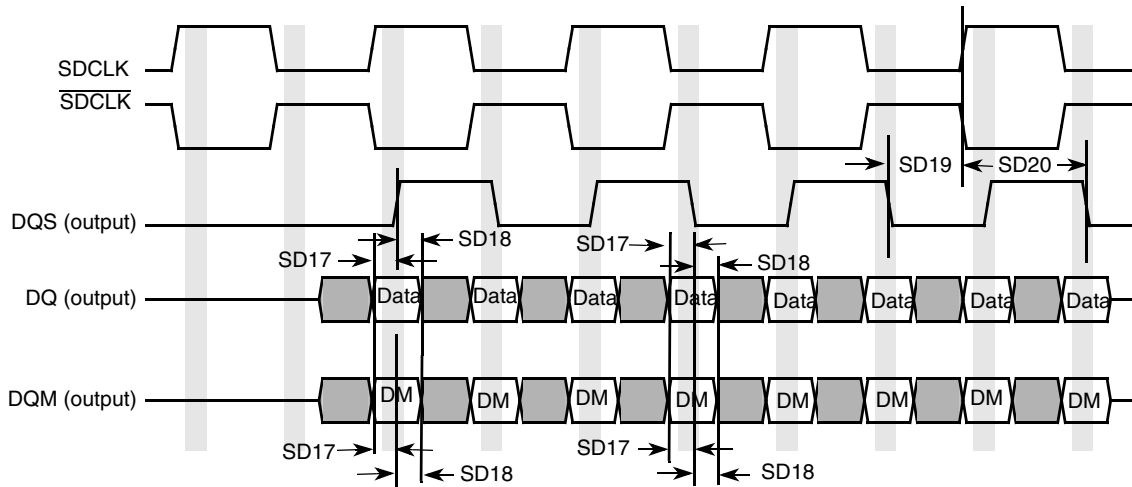

Figure 41. Mobile DDR SDRAM Write Cycle Timing Diagram

Table 41. Mobile DDR SDRAM Write Cycle Timing Parameters¹

ID	Parameter	Symbol	Min	Max	Unit
SD17	DQ and DQM setup time to DQS	tDS	0.95	—	ns
SD18	DQ and DQM hold time to DQS	tDH	0.95	—	ns
SD19	Write cycle DQS falling edge to SDCLK output delay time.	tDSS	1.8	—	ns
SD20	Write cycle DQS falling edge to SDCLK output hold time.	tDSH	1.8	—	ns

¹ Test condition: Measured using delay line 5 programmed as follows: ESDCDLY5[15:0] = 0x0703.

NOTE

SDRAM CLK and DQS related parameters are being measured from the 50% point—that is, high is defined as 50% of signal value and low is defined as 50% of signal value.

The timing parameters are similar to the ones used in SDRAM data sheets—that is, [Table 41](#) indicates SDRAM requirements. All output signals are driven by the ESDCTL at the negative edge of SDCLK and the parameters are measured at maximum memory frequency.

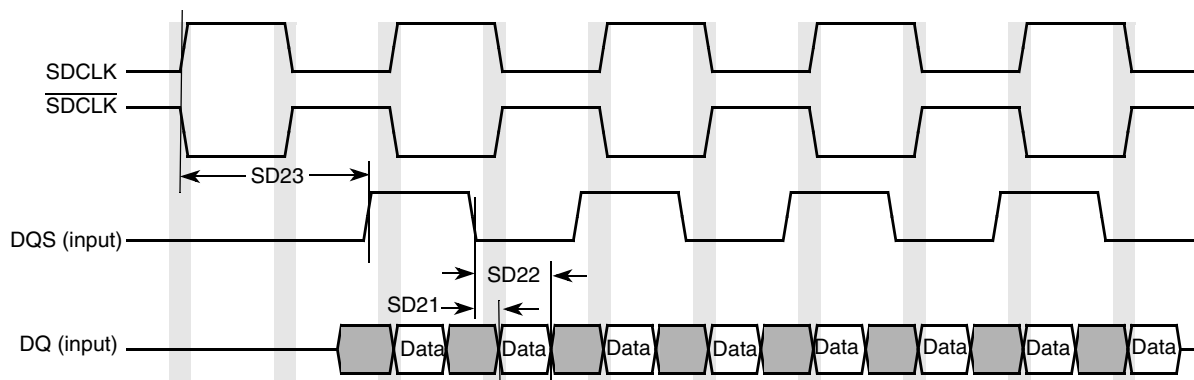

Figure 42. Mobile DDR SDRAM DQ versus DQS and SDCLK Read Cycle Timing Diagram

Table 42. Mobile DDR SDRAM Read Cycle Timing Parameters

ID	Parameter	Symbol	Min	Max	Unit
SD21	DQS–DQ Skew (defines the Data valid window in read cycles related to DQS).	tDQSQ	—	0.85	ns
SD22	DQS DQ HOLD time from DQS	tQH	2.3	—	ns
SD23	DQS output access time from SDCLK posedge	tDQSK	—	6.7	ns

NOTE

SDRAM CLK and DQS related parameters are being measured from the 50% point—that is, high is defined as 50% of signal value and low is defined as 50% of signal value.

The timing parameters are similar to the ones used in SDRAM data sheets—that is, [Table 42](#) indicates SDRAM requirements. All output signals are driven by the ESDCTL at the negative edge of SDCLK and the parameters are measured at maximum memory frequency.

4.3.10.1 SDHC Electrical DC Characteristics

[Table 43](#) lists the SDHC electrical DC characteristics.

Table 43. SDHC Electrical DC Characteristics

ID	Parameter	Min	Max	Unit	Comments
General					
SD10	Peak Voltage on All Lines	-0.3	$V_{DD} + 0.3$	V	—
All Inputs					
SD11	Input Leakage Current	-10	10	μA	—
All Outputs					
SD12	Output Leakage Current	-10	10	μA	—

Table 43. SDHC Electrical DC Characteristics

ID	Parameter	Min	Max	Unit	Comments
Power Supply					
SD13	Supply Voltage (low voltage)	1.65	1.95	V	1.95 ~2.7 V is not supported.
SD14	Supply Voltage (high voltage)	2.7	3.6	V	
SD15	Power Up Time	—	250	ms	—
SD16	Supply Current	100	—	mA	—
Bus Signal Line Load					
SD17	Pull-up Resistance	10	100	k Ω	Internal PU
SD18	Open Drain Resistance	NA	NA	k Ω	For MMC cards only
Open Drain Signal Level					—
SD19	Output High Voltage	$V_{DD} - 0.2$	—	V	$I_{OH} = -100$ mA
SD20	Output Low Voltage	—	0.3	V	$I_{OL} = 2$ mA
Push-Pull Signal Levels (High Voltage)					
SD21	Output HIGH Voltage	$0.75 \times V_{DD}$	—	V	$I_{OH} = -100$ mA @ V_{DD} min
SD22	Output LOW Voltage	—	$0.125 \times V_{DD}$	V	$I_{OL} = 100$ mA @ V_{DD} min
SD23	Input HIGH Voltage	$0.625 \times V_{DD}$	$V_{DD} + 0.3$	V	—
SD24	Input LOW Voltage	$V_{SS} - 0.3$	$0.25 \times V_{DD}$	V	—
Push-Pull Signal Levels (Low Voltage)					
SD25	Output HIGH Voltage	$V_{DD} - 0.2$	—	V	$I_{OH} = -100$ mA @ V_{DD} min
SD26	Output LOW Voltage	—	0.2	V	$I_{OL} = 100$ mA @ V_{DD} min
SD27	Input HIGH Voltage	$0.7 \times V_{DD}$	$V_{DD} + 0.3$	V	—
SD28	Input LOW Voltage	$V_{SS} - 0.3$	$0.3 \times V_{DD}$	V	—

4.3.11 Smart Liquid Crystal Display Controller (SLCDC)

Figure 43 and Figure 44 show the timings of the SLCDC, and Table 44 and Table 45 list the timing parameters.

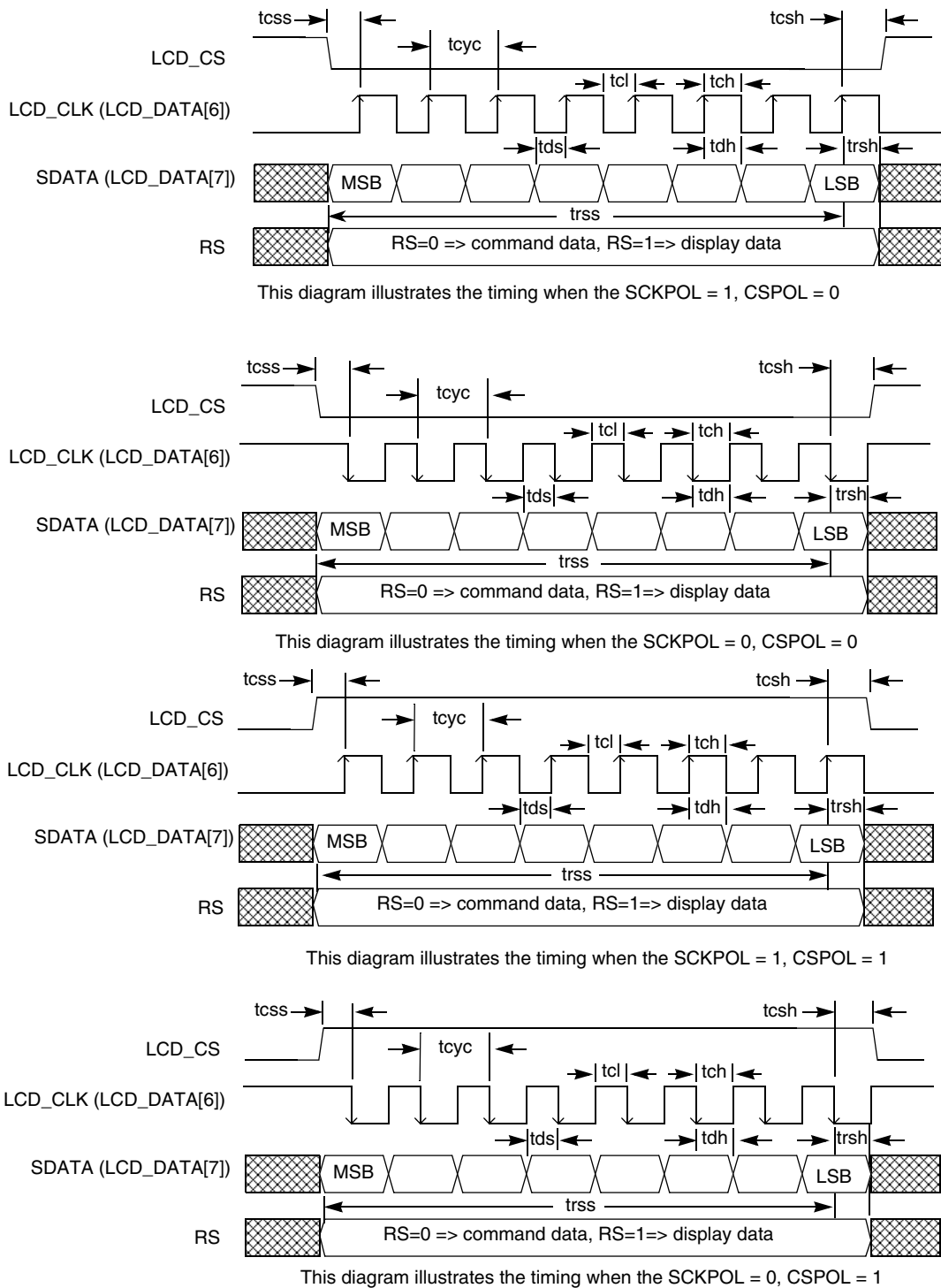
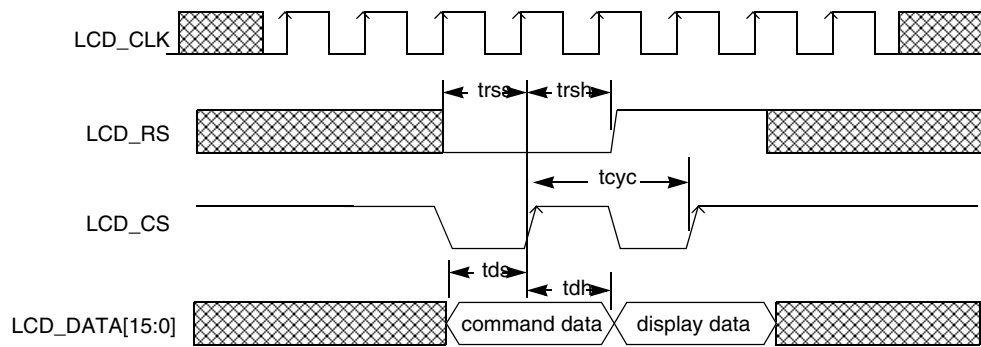

Figure 43. SLCDC Timing Diagram—Serial Transfers to LCD Device

Table 44. SLCDC Serial Interface Timing Parameters

Symbol	Parameter	Min	Typical	Max	Units
t_{css}	Chip select setup time	$(t_{cyc} / 2) (\pm) t_{prop}$	—	—	ns
t_{csh}	Chip select hold time	$(t_{cyc} / 2) (\pm) t_{prop}$	—	—	ns
t_{cyc}	Serial clock cycle time	$39 (\pm) t_{prop}$	—	2641	ns
t_{cl}	Serial clock low pulse	$18 (\pm) t_{prop}$	—	—	ns
t_{ch}	Serial clock high pulse	$18 (\pm) t_{prop}$	—	—	ns
t_{ds}	Data setup time	$(t_{cyc} / 2) (\pm) t_{prop}$	—	—	ns
t_{dh}	Data hold time	$(t_{cyc} / 2) (\pm) t_{prop}$	—	—	ns
t_{rss}	Register select setup time	$(15 * t_{cyc} / 2) (\pm) t_{prop}$	—	—	ns
t_{rsh}	Register select hold time	$(t_{cyc} / 2) (\pm) t_{prop}$	—	—	ns



This diagram illustrates the timing when CSPOL=0

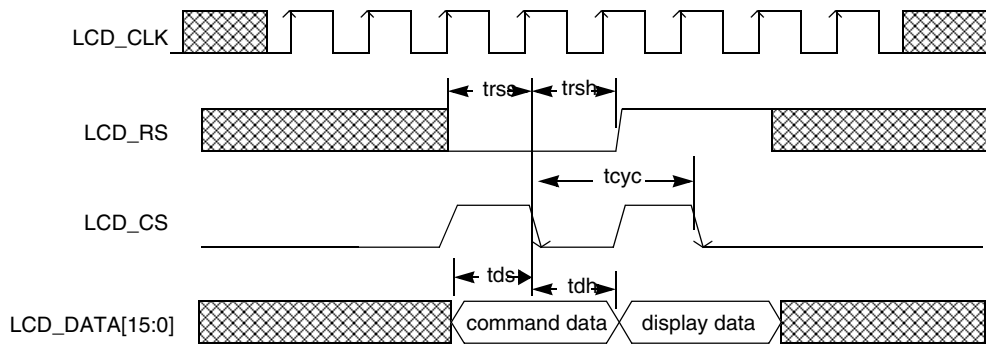

This diagram illustrates the timing when CSPOL=1

Figure 44. SLCDC Timing Diagram—Parallel Transfers to LCD Device

Table 45. SLCDC Parallel Interface Timing Parameters

Symbol	Parameter	Min	Typical	Max	Units
t_{cyc}	Parallel clock cycle time	$78 (\pm) t_{prop}$	—	4923	—
t_{ds}	Data setup time	$(t_{cyc} / 2) (\pm) t_{prop}$	—	—	—
t_{dh}	Data hold time	$(t_{cyc} / 2) (\pm) t_{prop}$	—	—	—

Table 45. SLCDC Parallel Interface Timing Parameters (continued)

Symbol	Parameter	Min	Typical	Max	Units
t_{rss}	Register select setup time	$(t_{cyc} / 2) (\pm) t_{prop}$	—	—	—
t_{rsh}	Register select hold time	$(t_{cyc} / 2) (\pm) t_{prop}$	—	—	—

4.3.12 Synchronous Serial Interface (SSI)

This section describes the electrical information of SSI.

4.3.12.1 SSI Transmitter Timing with Internal Clock

Figure 45 and Figure 46 show the SSI transmitter timing with internal clock, and Table 46 lists the timing parameters.

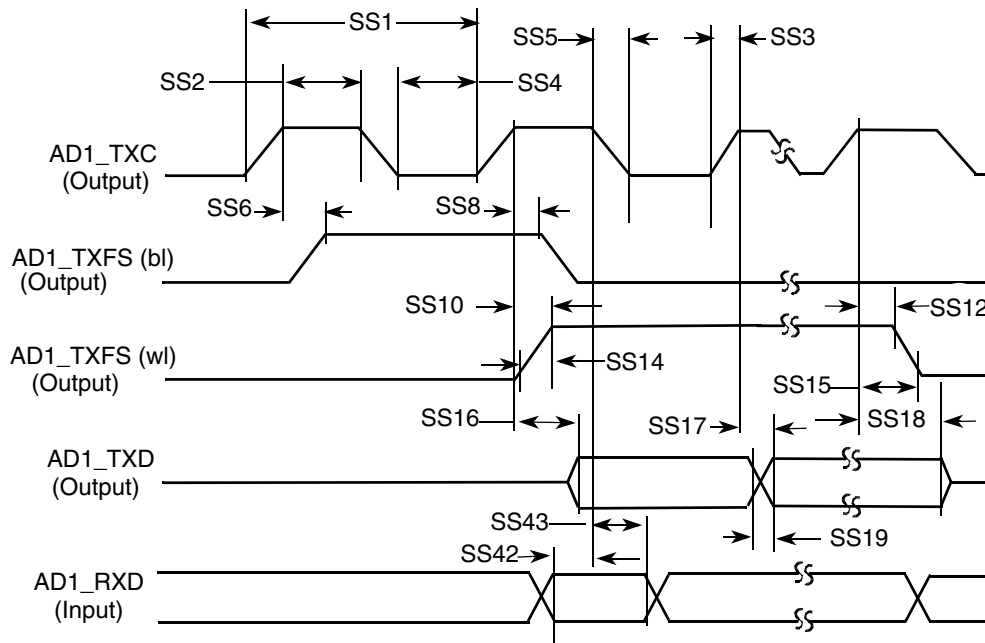

Note: SRXD Input in Synchronous mode only

Figure 45. SSI Transmitter with Internal Clock Timing Diagram

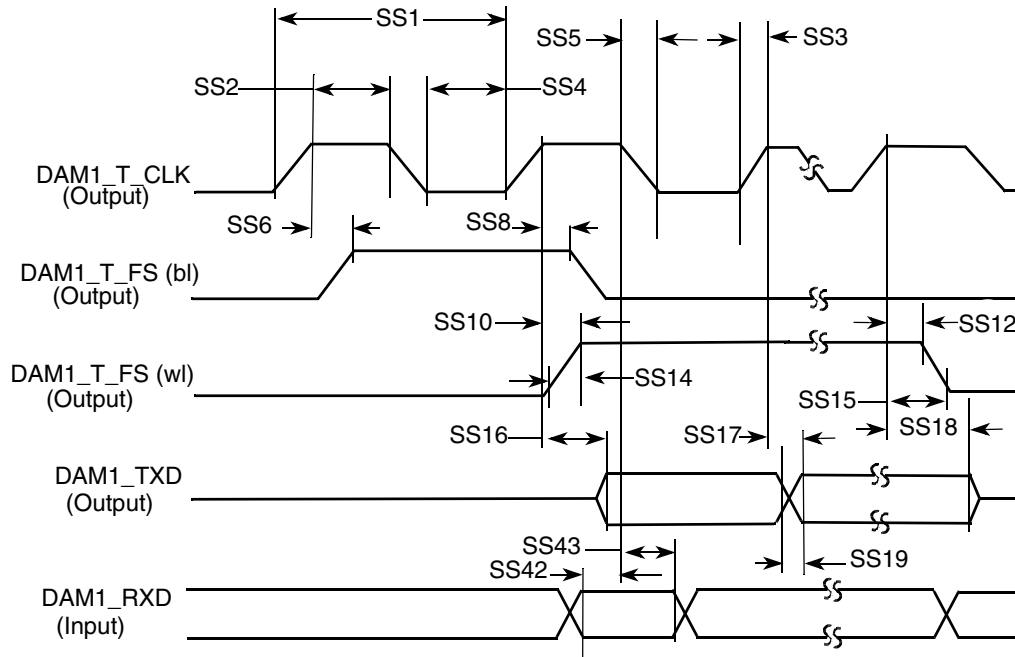

Note: SRXD Input in Synchronous mode only

Figure 46. SSI Transmitter with Internal Clock Timing Diagram

Table 46. SSI Transmitter with Internal Clock Timing Parameters

ID	Parameter	Min	Max	Unit
Internal Clock Operation				
SS1	(Tx/Rx) CK clock period	81.4	—	ns
SS2	(Tx/Rx) CK clock high period	36.0	—	ns
SS3	(Tx/Rx) CK clock rise time	—	6	ns
SS4	(Tx/Rx) CK clock low period	36.0	—	ns
SS5	(Tx/Rx) CK clock fall time	—	6	ns
SS6	(Tx) CK high to FS (bl) high	—	15.0	ns
SS8	(Tx) CK high to FS (bl) low	—	15.0	ns
SS10	(Tx) CK high to FS (wl) high	—	15.0	ns
SS12	(Tx) CK high to FS (wl) low	—	15.0	ns
SS14	(Tx/Rx) Internal FS rise time	—	6	ns
SS15	(Tx/Rx) Internal FS fall time	—	6	ns
SS16	(Tx) CK high to STXD valid from high impedance	—	15.0	ns
SS17	(Tx) CK high to STXD high/low	—	15.0	ns
SS18	(Tx) CK high to STXD high impedance	—	15.0	ns
SS19	STXD rise/fall time	—	6	ns

Table 46. SSI Transmitter with Internal Clock Timing Parameters (continued)

ID	Parameter	Min	Max	Unit
Synchronous Internal Clock Operation				
SS42	SRXD setup before (Tx) CK falling	10.0	—	ns
SS43	SRXD hold after (Tx) CK falling	0	—	ns
SS52	Loading	—	25	pF

- All the timings for the SSI are given for a non-inverted serial clock polarity (TSCKP/RSCKP = 0) and a non-inverted frame sync (TFSI/RFSI = 0). If the polarity of the clock and/or the frame sync have been inverted, all the timing remains valid by inverting the clock signal STCK/SRCK and/or the frame sync STFS/SRFS shown in the tables and in the figures.
- All timings are on AUDMUX pads when SSI is being used for data transfer.
- “Tx” and “Rx” refer to the Transmit and Receive sections of the SSI.
- For internal Frame Sync operation using external clock, the FS timing will be same as that of Tx Data (for example, during AC97 mode of operation).

4.3.12.2 SSI Receiver Timing with Internal Clock

Figure 47 and Figure 48 show the SSI receiver timing with internal clock, and Table 47 lists the timing parameters.

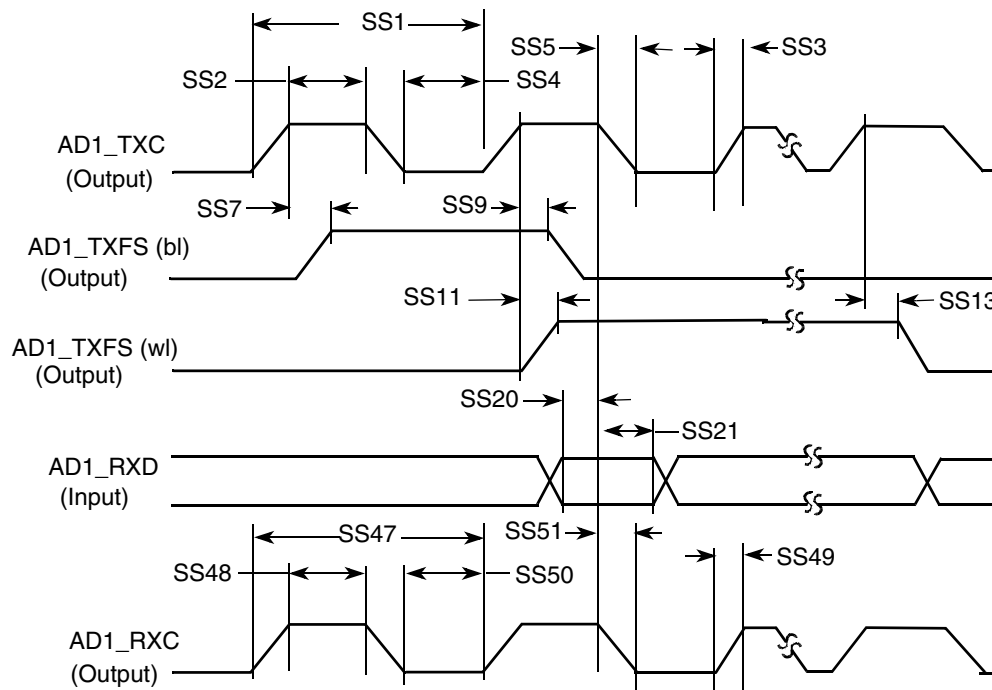
**Figure 47. SSI Receiver with Internal Clock Timing Diagram**

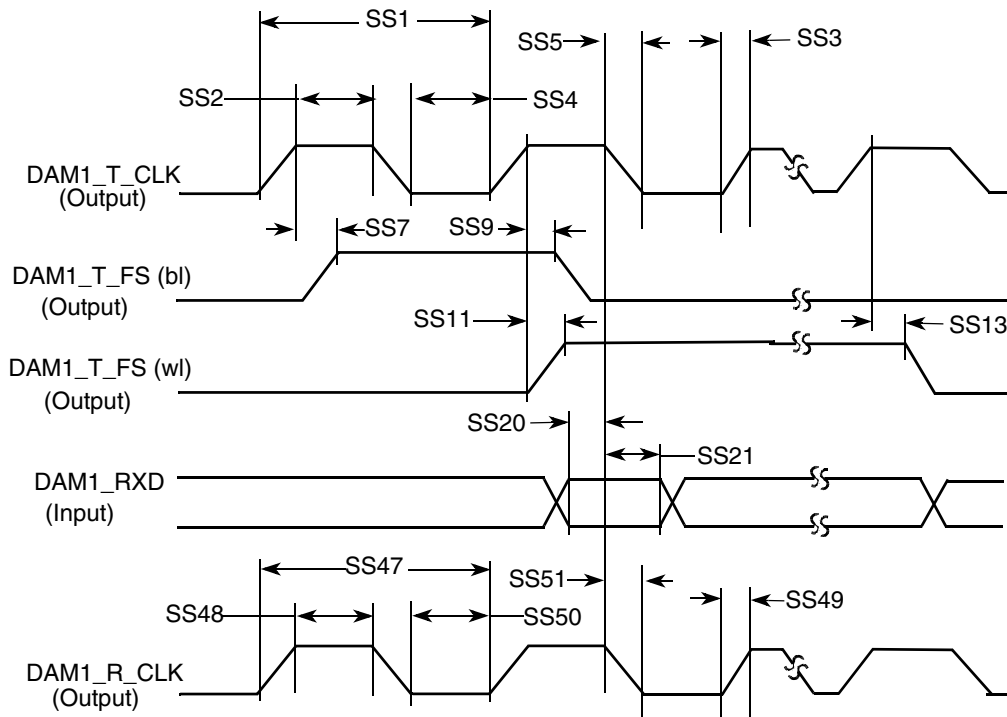

Figure 48. SSI Receiver with Internal Clock Timing Diagram

Table 47. SSI Receiver with Internal Clock Timing Parameters

ID	Parameter	Min	Max	Unit
Internal Clock Operation				
SS1	(Tx/Rx) CK clock period	81.4	—	ns
SS2	(Tx/Rx) CK clock high period	36.0	—	ns
SS3	(Tx/Rx) CK clock rise time	—	6	ns
SS4	(Tx/Rx) CK clock low period	36.0	—	ns
SS5	(Tx/Rx) CK clock fall time	—	6	ns
SS7	(Rx) CK high to FS (bl) high	—	15.0	ns
SS9	(Rx) CK high to FS (bl) low	—	15.0	ns
SS11	(Rx) CK high to FS (wl) high	—	15.0	ns
SS13	(Rx) CK high to FS (wl) low	—	15.0	ns
SS20	SRXD setup time before (Rx) CK low	10.0	—	ns
SS21	SRXD hold time after (Rx) CK low	0	—	ns
Oversampling Clock Operation				
SS47	Oversampling clock period	15.04	—	ns
SS48	Oversampling clock high period	6	—	ns

Table 47. SSI Receiver with Internal Clock Timing Parameters (continued)

ID	Parameter	Min	Max	Unit
SS49	Oversampling clock rise time	—	3	ns
SS50	Oversampling clock low period	6	—	ns
SS51	Oversampling clock fall time	—	3	ns

NOTE

All the timings for the SSI are given for a non-inverted serial clock polarity (TSCKP/RSCKP = 0) and a non-inverted frame sync (TFSI/RFSI = 0). If the polarity of the clock and/or the frame sync have been inverted, all the timing remains valid by inverting the clock signal STCK/SRCK and/or the frame sync STFS/SRFS shown in the tables and in the figures.

All timings are on AUDMUX pads when SSI is being used for data transfer.

“Tx” and “Rx” refer to the Transmit and Receive sections of the SSI.

For internal Frame Sync operation using external clock, the FS timing is the same as that of Tx Data, for example, during the AC97 mode of operation.

4.3.12.3 SSI Transmitter Timing with External Clock

Figure 49 and Figure 50 show the SSI transmitter timing with external clock, and Table 48 lists the timing parameters.

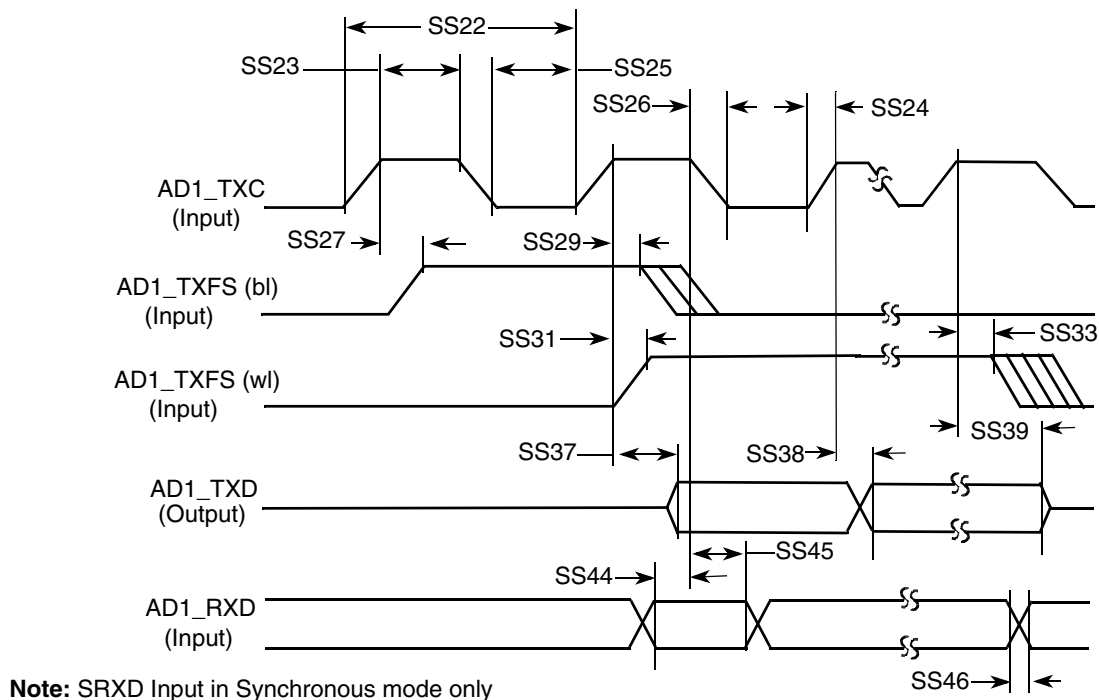
**Figure 49. SSI Transmitter with External Clock Timing Diagram**

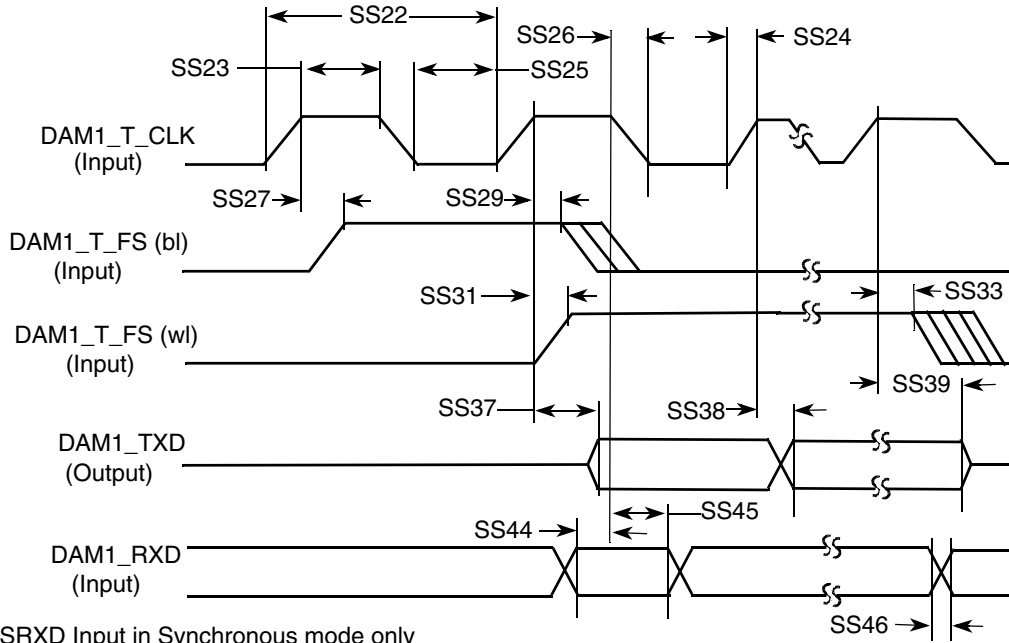

Note: SRXD Input in Synchronous mode only

Figure 50. SSI Transmitter with External Clock Timing Diagram

Table 48. SSI Transmitter with External Clock Timing Parameters

ID	Parameter	Min	Max	Unit
External Clock Operation				
SS22	(Tx/Rx) CK clock period	81.4	—	ns
SS23	(Tx/Rx) CK clock high period	36.0	—	ns
SS24	(Tx/Rx) CK clock rise time	—	6.0	ns
SS25	(Tx/Rx) CK clock low period	36.0	—	ns
SS26	(Tx/Rx) CK clock fall time	—	6.0	ns
SS27	(Tx) CK high to FS (bl) high	-10.0	15.0	ns
SS29	(Tx) CK high to FS (bl) low	10.0	—	ns
SS31	(Tx) CK high to FS (wl) high	-10.0	15.0	ns
SS33	(Tx) CK high to FS (wl) low	10.0	—	ns
SS37	(Tx) CK high to STXD valid from high impedance	—	15.0	ns
SS38	(Tx) CK high to STXD high/low	—	15.0	ns
SS39	(Tx) CK high to STXD high impedance	—	15.0	ns
Synchronous External Clock Operation				
SS44	SRXD setup before (Tx) CK falling	10.0	—	ns
SS45	SRXD hold after (Tx) CK falling	2.0	—	ns
SS46	SRXD rise/fall time	—	6.0	ns

NOTE

All the timings for the SSI are given for a non-inverted serial clock polarity (TSCKP/RSCKP = 0) and a non-inverted frame sync (TFSI/RFSI = 0). If the polarity of the clock and/or the frame sync have been inverted, all the timing remains valid by inverting the clock signal STCK/SRCK and/or the frame sync STFS/SRFS shown in the tables and in the figures.

All timings are on AUDMUX pads when the SSI is being used for data transfer.

“Tx” and “Rx” refer to the Transmit and Receive sections of the SSI.

For internal Frame Sync operation using external clock, the FS timing will be same as that of Tx Data, for example, during the AC97 mode of operation.

4.3.12.4 SSI Receiver Timing with External Clock

Figure 51 and Figure 52 show the SSI receiver timing with external clock, and Table 49 lists the timing parameters.

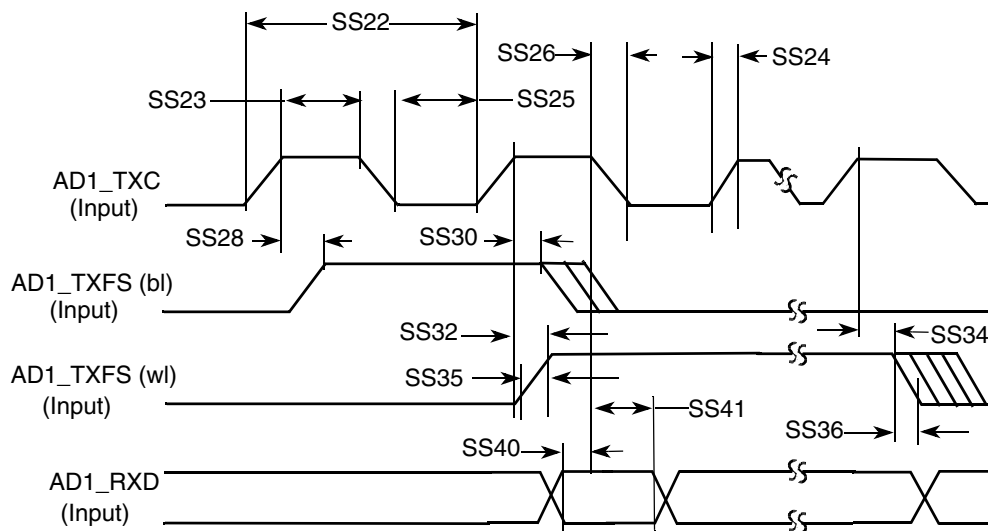

Figure 51. SSI Receiver with External Clock Timing Diagram

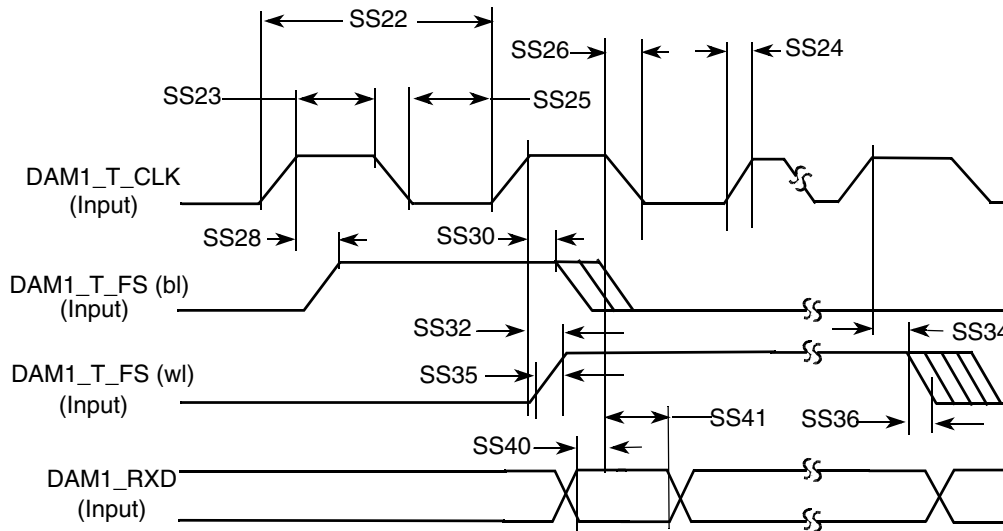

Figure 52. SSI Receiver with External Clock Timing Diagram

Table 49. SSI Receiver with External Clock Timing Parameters

ID	Parameter	Min	Max	Unit
External Clock Operation				
SS22	(Tx/Rx) CK clock period	81.4	—	ns
SS23	(Tx/Rx) CK clock high period	36.0	—	ns
SS24	(Tx/Rx) CK clock rise time	—	6.0	ns
SS25	(Tx/Rx) CK clock low period	36.0	—	ns
SS26	(Tx/Rx) CK clock fall time	—	6.0	ns
SS28	(Rx) CK high to FS (bl) high	-10.0	15.0	ns
SS30	(Rx) CK high to FS (bl) low	10.0	—	ns
SS32	(Rx) CK high to FS (wl) high	-10.0	15.0	ns
SS34	(Rx) CK high to FS (wl) low	10.0	—	ns
SS35	(Tx/Rx) External FS rise time	—	6.0	ns
SS36	(Tx/Rx) External FS fall time	—	6.0	ns
SS40	SRXD setup time before (Rx) CK low	10.0	—	ns
SS41	SRXD hold time after (Rx) CK low	2.0	—	ns

NOTE

All the timings for the SSI are given for a non-inverted serial clock polarity (TSCKP/RSCKP = 0) and a non-inverted frame sync (TFSI/RFSI = 0). If the polarity of the clock and/or the frame sync have been inverted, all the timing remains valid by inverting the clock signal STCK/SRCK and/or the frame sync STFS/SRFS shown in the tables and in the figures.

All timings are on AUDMUX pads when the SSI is being used for data transfer.

“Tx” and “Rx” refer to the Transmit and Receive sections of the SSI.

For internal Frame Sync operation using external clock, the FS timing will be same as that of Tx Data, for example, during the AC97 mode of operation.

4.3.13 Wireless External Interface Module (WEIM)

All WEIM output control signals may be asserted and deasserted by internal clock related to BCLK rising edge or falling edge according to corresponding assertion/negation control fields. Address always begins related to BCLK falling edge but may be ended both on rising and falling edge in muxed mode according to control register configuration. Output data begins related to BCLK rising edge except in muxed mode where both rising and falling edge may be used according to control register configuration. Input data, \overline{ECB} and \overline{DTACK} all captured according to BCLK rising edge time. [Figure 53](#) shows the timing of the WEIM module, and [Table 50](#) lists the timing parameters.

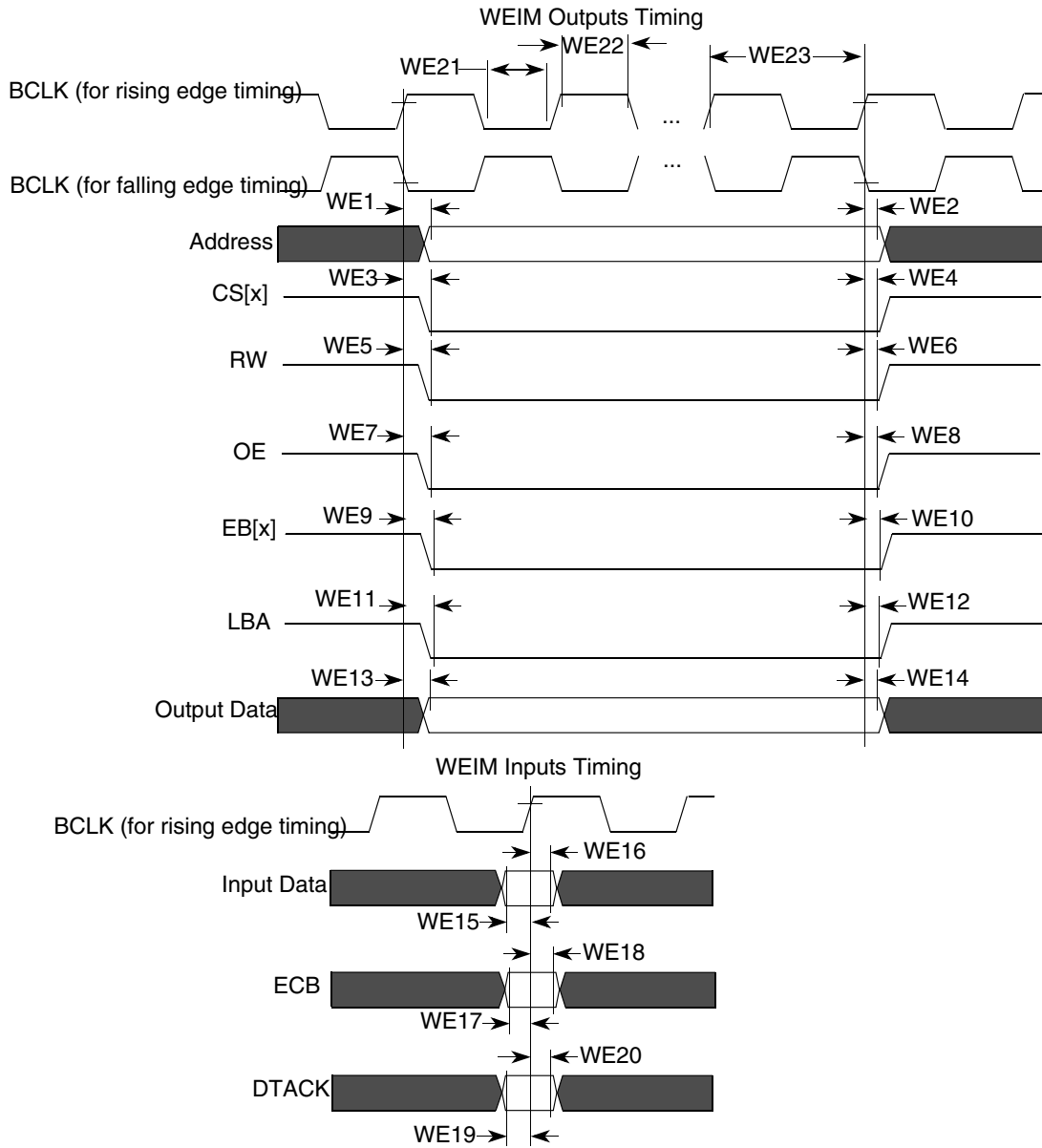

Figure 53. WEIM Bus Timing Diagram

Table 50. WEIM Bus Timing Parameters

ID	Parameter	1.8 V		Unit
		Min	Max	
WE1	Clock fall to address valid	0.68	2.05	ns
WE2	Clock rise/fall to address invalid	0.68	2.49	ns
WE3	Clock rise/fall to $\overline{CS}[x]$ valid	0.45	2.25	ns
WE4	Clock rise/fall to $\overline{CS}[x]$ invalid	0.45	2.25	ns

Table 50. WEIM Bus Timing Parameters (continued)

ID	Parameter	1.8 V		Unit
		Min	Max	
WE5	Clock rise/fall to \overline{RW} Valid	0.90	2.60	ns
WE6	Clock rise/fall to \overline{RW} Invalid	0.90	2.60	ns
WE7	Clock rise/fall to \overline{OE} Valid	1.17	3.57	ns
WE8	Clock rise/fall to \overline{OE} Invalid	1.17	3.57	ns
WE9	Clock rise/fall to $\overline{EB[x]}$ Valid	0.73	2.43	ns
WE10	Clock rise/fall to $\overline{EB[x]}$ Invalid	0.73	2.43	ns
WE11	Clock rise/fall to \overline{LBA} Valid	1.03	2.84	ns
WE12	Clock rise/fall to \overline{LBA} Invalid	1.03	2.84	ns
WE13	Clock rise/fall to Output Data Valid	1.04	4.01	ns
WE14	Clock rise to Output Data Invalid	1.04	4.01	ns
WE15	Input Data Valid to Clock rise, FCE=0 (in the case there is ECB_B asserted during access)	1/2BCLK +3.6	—	ns
WE15	Input Data Valid to Clock rise, FCE=0 (in the case there is NO ECB_B asserted during access)	6.95	—	ns
WE16	Clock rise to Input Data Invalid, FCE=0	2.35	—	ns
WE17	Input Data Valid to Clock rise, FCE=1	1.24	—	ns
WE18	Clock rise to Input Data Invalid, FCE=1	0.23	—	ns
WE19	\overline{ECB} setup time, FCE=0	7.23	—	ns
WE20	\overline{ECB} hold time, FCE=0	2.93	—	ns
WE21	\overline{ECB} setup time, FCE=1	1.08	—	ns
WE22	\overline{ECB} hold time, FCE=1	0	—	ns
WE23	\overline{DTACK} setup time	5.35	—	ns
WE24	\overline{DTACK} hold time	3.19	—	ns
WE25	BCLK High Level Width ¹	3.0	—	ns
WE26	BCLK Low Level Width ¹	3.0	—	ns
WE27	BCLK Cycle time ¹	7.5	—	ns

¹ BCLK parameters are being measured from the 50% point—that is, high is defined as 50% of signal value and low is defined as 50% of signal value.

NOTE

High is defined as 80% of signal value and low is defined as 20% of signal value.

Electrical Characteristics

Test conditions: pad voltage, 1.7–1.95 V; pad capacitance, 25 pF.
 Recommended drive strength for all controls, address, and BCLK is Max High.

Figure 54, Figure 55, Figure 56, Figure 57, Figure 58, and Figure 59 show examples of basic WEIM accesses to external memory devices with the timing parameters mentioned in Table 50 for specific control parameter settings.

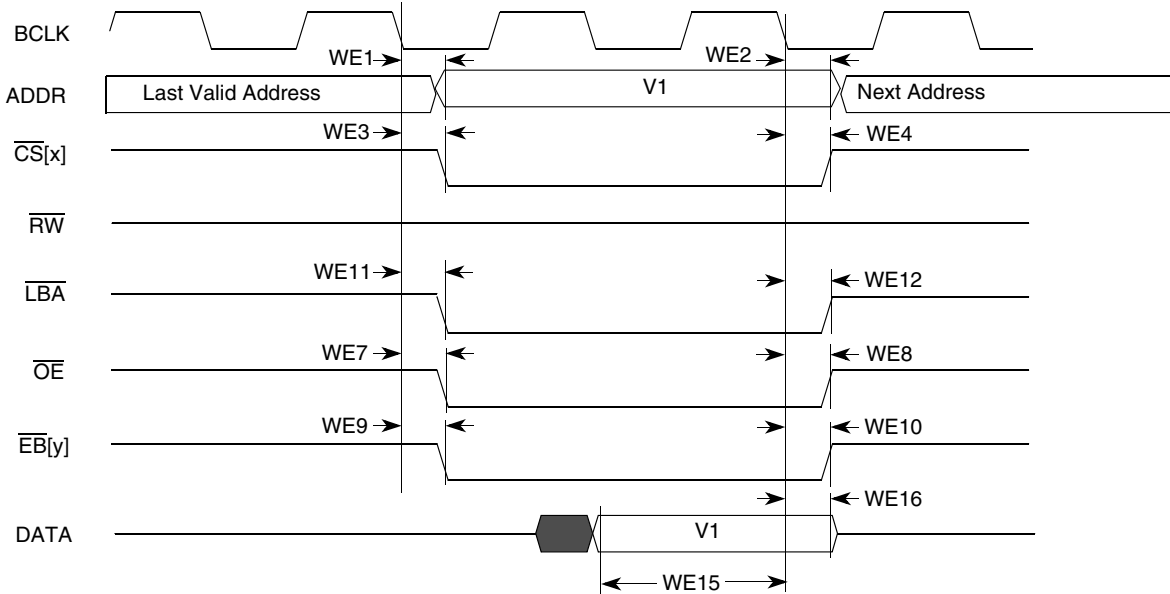

Figure 54. Asynchronous Memory Timing Diagram for Read Access—WSC=1

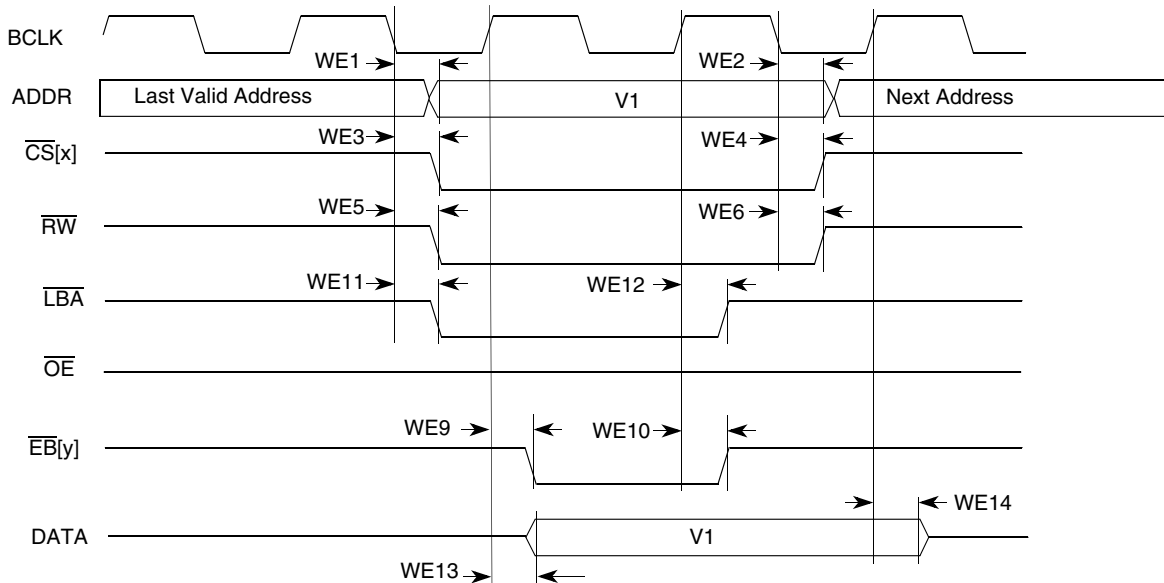

Figure 55. Asynchronous Memory Timing Diagram for Write Access—WSC=1, EBWA=1, EBWN=1, LBN=1

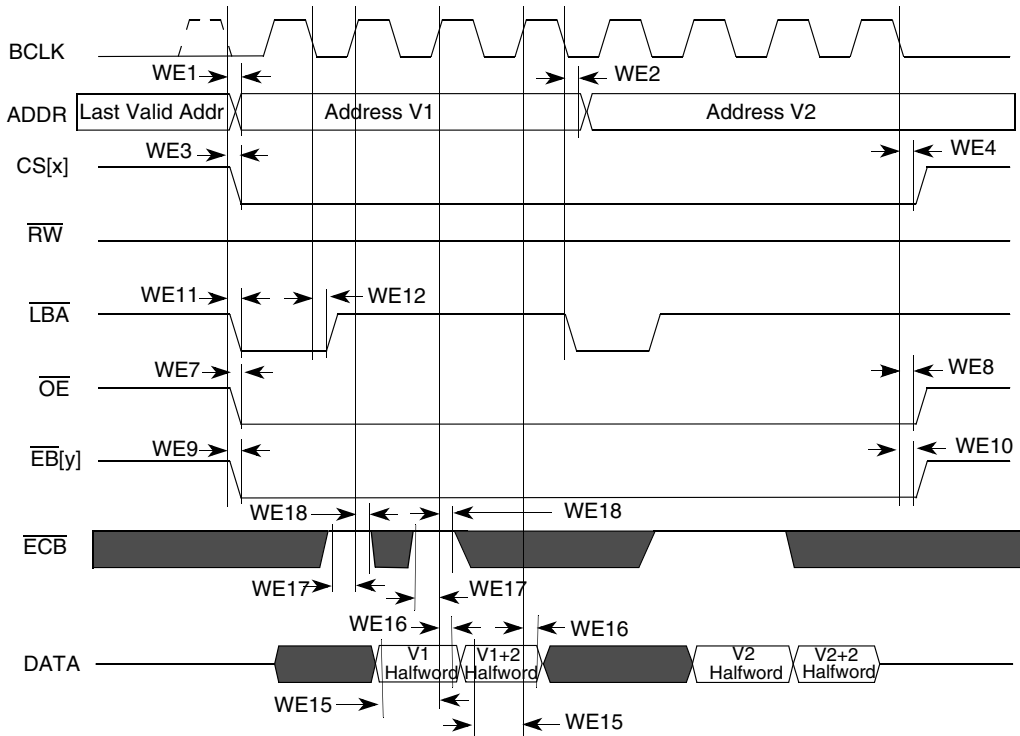

Figure 56. Synchronous Memory Timing Diagram for Two Non-Sequential Read Accesses: WSC=2, SYNC=1, DOL=0

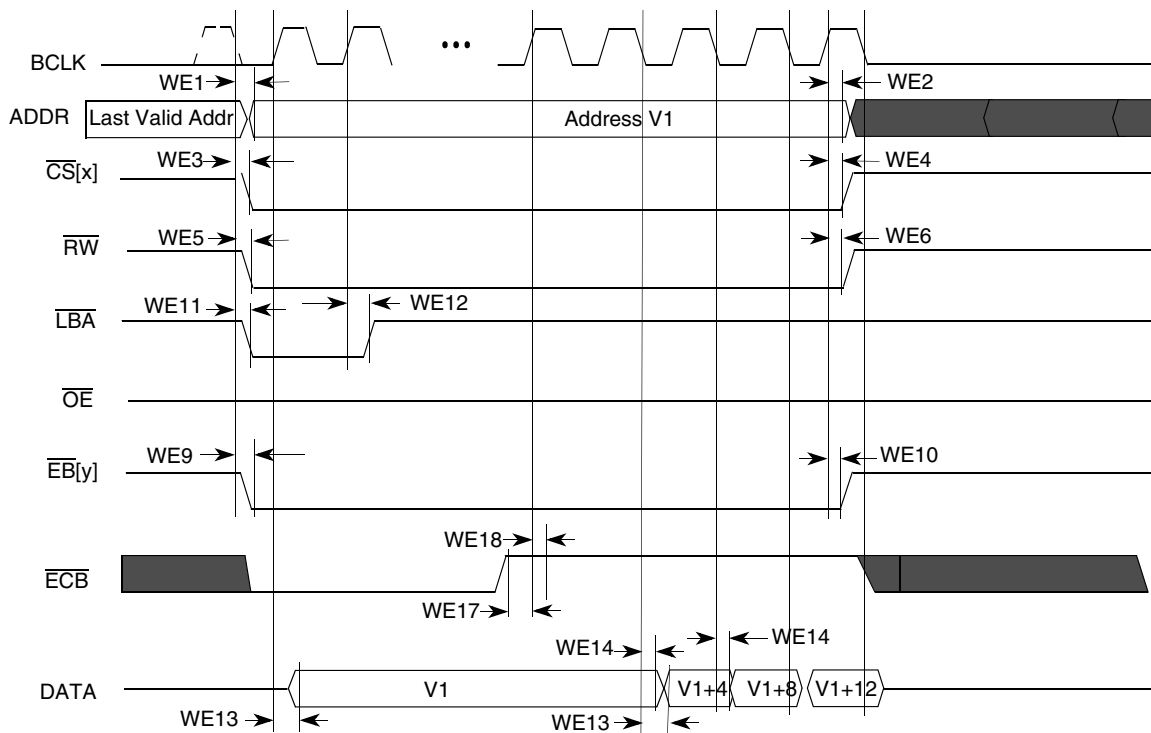

Figure 57. Synchronous Memory Timing Diagram for Burst Write Access—BCS=1, WSC=4, SYNC=1, DOL=0, PSR=1

Electrical Characteristics

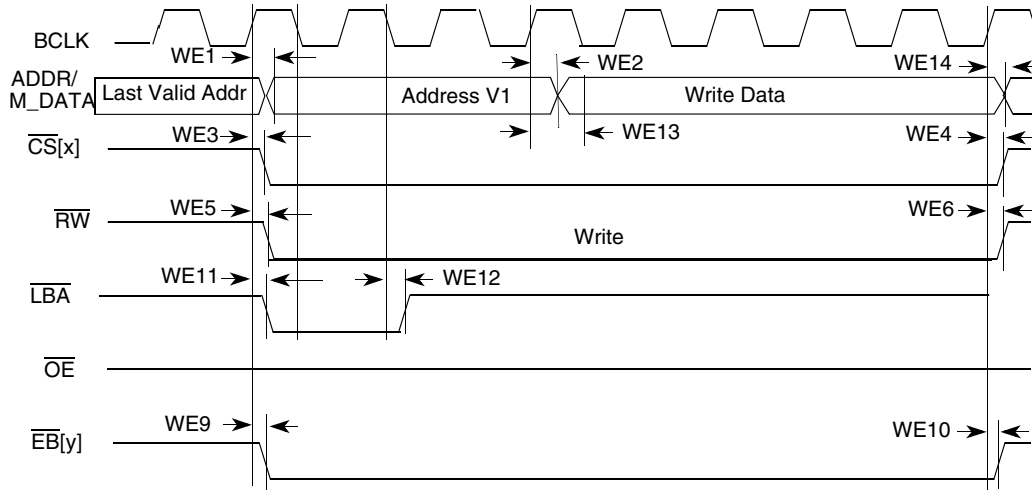

Figure 58. Muxed A/D Mode Timing Diagram for Asynchronous Write Access—WSC=7, LBA=1, LBN=1, LAH=1

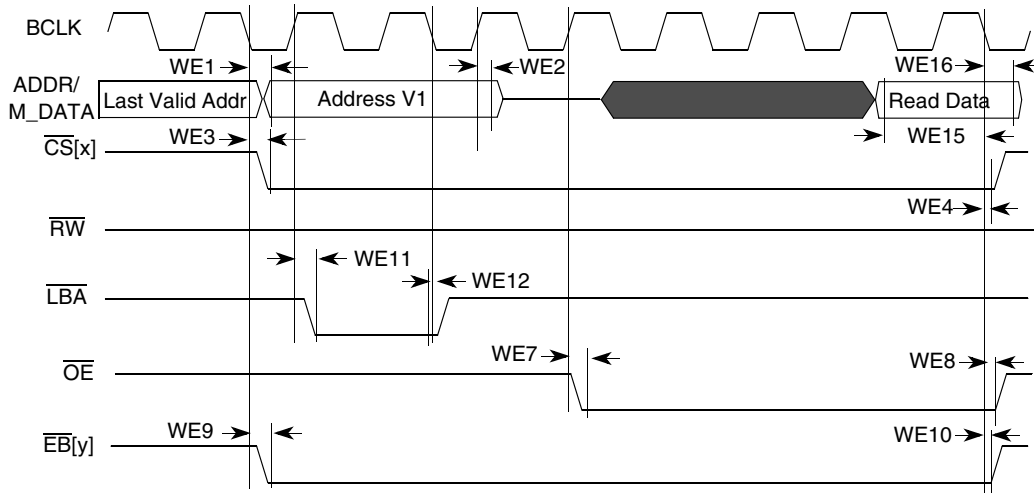

Figure 59. Muxed A/D Mode Timing Diagram for Asynchronous Read Access—WSC=7, LBA=1, LBN=1, LAH=1, OEA=7

4.3.13.1 WEIM Synchronous Mode Sample Point

Figure 60 shows that the AHB first sample point is the time marker A.

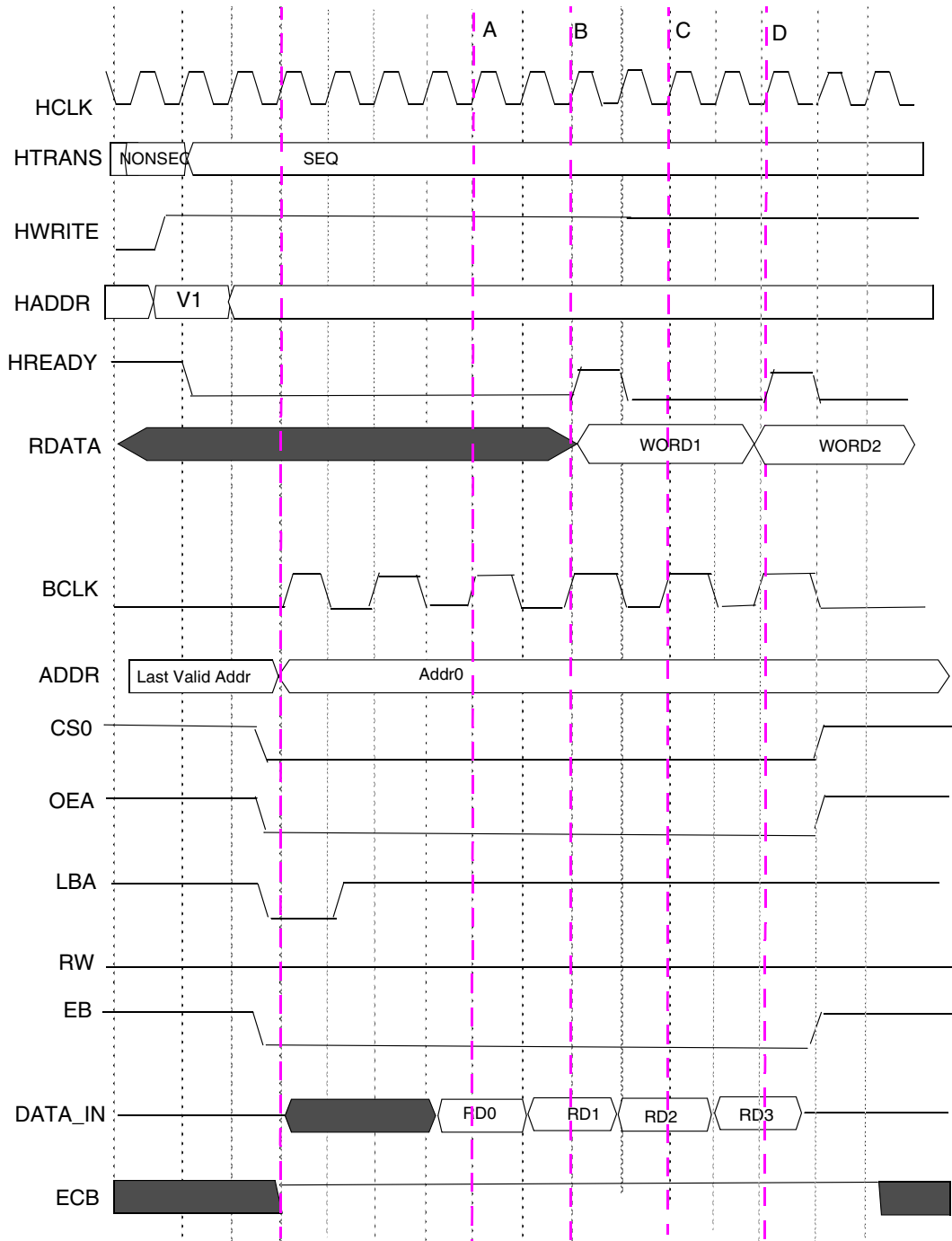

Figure 60. FCE=0,SYNC=1,BCD=1,WSC=4,BCS=0,CSA=0,OEA=0

Figure 61 shows that the AHB first sample point is the time marker A.

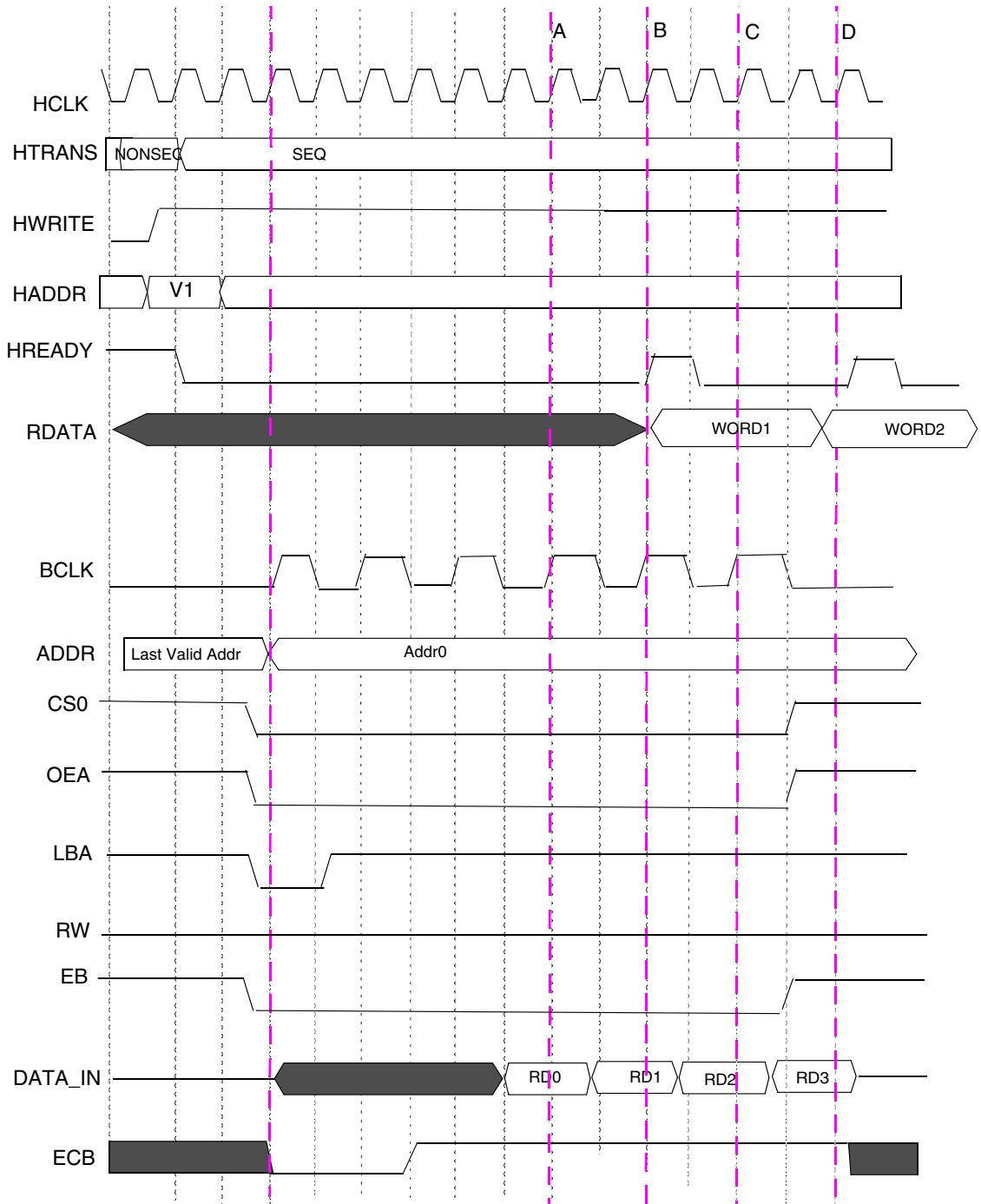

Figure 61. FCE=0,SYNC=1,BCD=1,WSC=6,BCS=0,CSA=0,OEA=0

Figure 62 shows that the AHB first sample point is the time marker A.

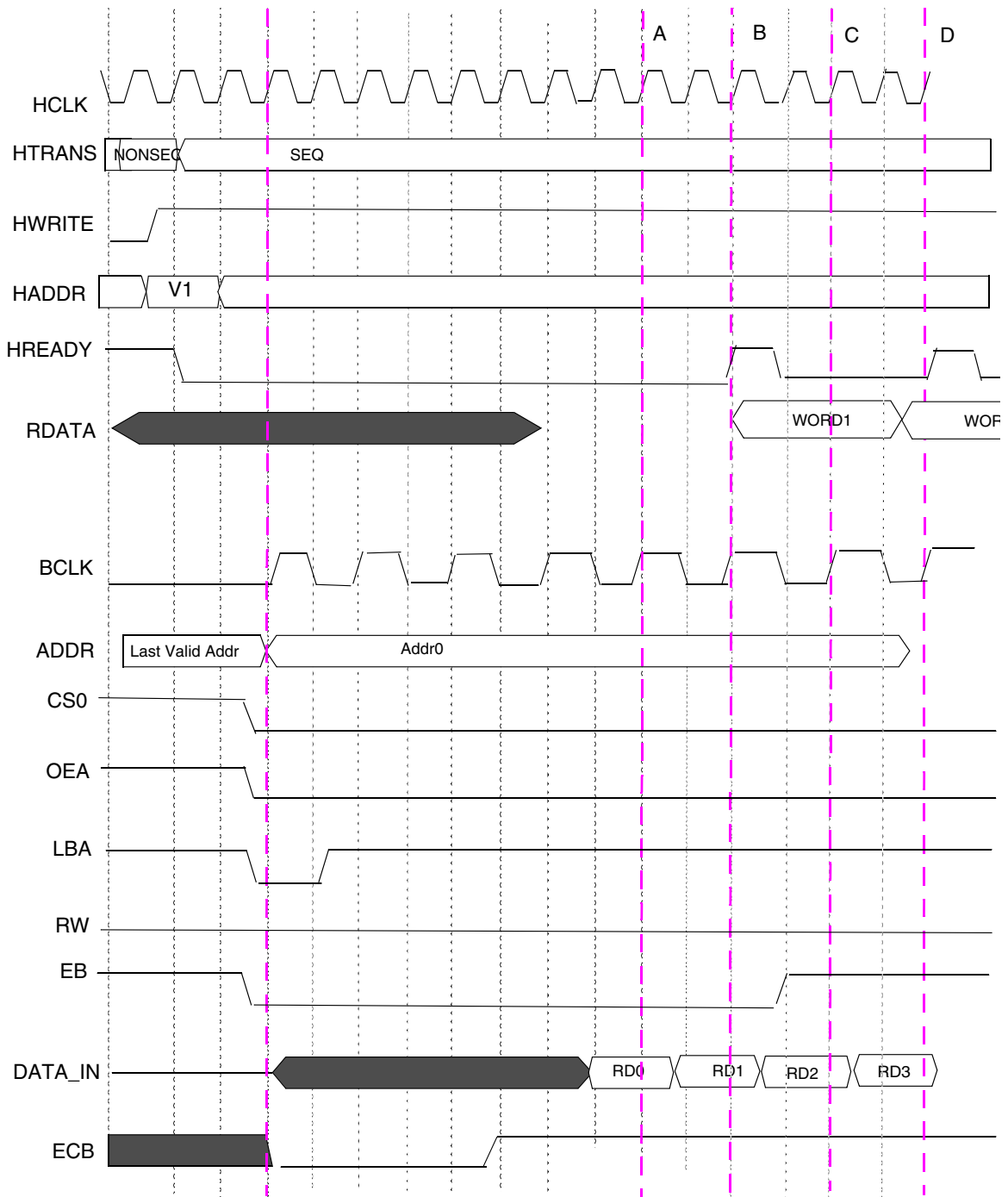

Figure 62. FCE=0,SYNC=1,BCD=1,WSC=8,BCS=0,CSA=0,OEA=0

Figure 63 shows that the AHB first sample point is the time marker A, If ECB is asserted during access, the sample point will be changed to the negative of the BCLK (just like the sample point C&D).

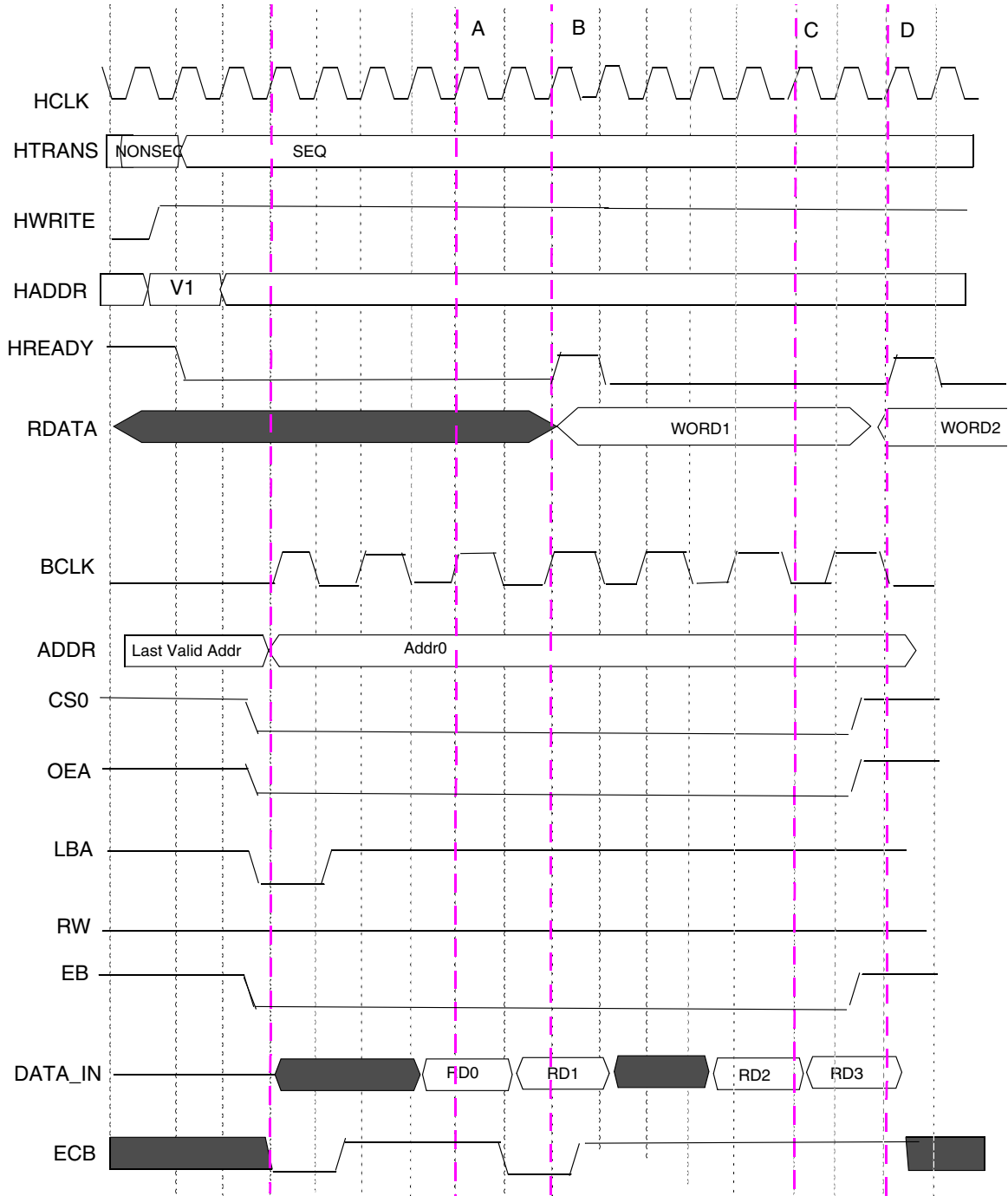

Figure 63. FCE=0,SYNC=1,BCD=1,WSC=4,BCS=0,CSA=0, OEA=0

4.3.14 USBOTG Electricals

This section describes the electrical information of the USB OTG port and host ports.

4.3.15 Serial Interface

In order to support four serial different interfaces, the USBOTG transceiver can be configured to operate in one of the following modes:

- DAT_SE0 bidirectional, 3-wire mode
- DAT_SE0 unidirectional, 6-wire mode
- VP_VM bidirectional, 4-wire mode
- VP_VM unidirectional, 6-wire mode

4.3.15.1 DAT_SE0 Bidirectional Mode

Table 51. Signal Definitions—DAT_SE0 Bidirectional Mode

Name	Direction	Signal Description
USB_TXOE_B	Out	<ul style="list-style-type: none"> • Transmit enable, active low
USB_DAT_VP	Out In	<ul style="list-style-type: none"> • TX data when USB_TXOE_B is low • Differential RX data when USB_TXOE_B is high
USB_SE0_VM	Out In	<ul style="list-style-type: none"> • SE0 drive when USB_TXOE_B is low • SE0 RX indicator when USB_TXOE_B is high

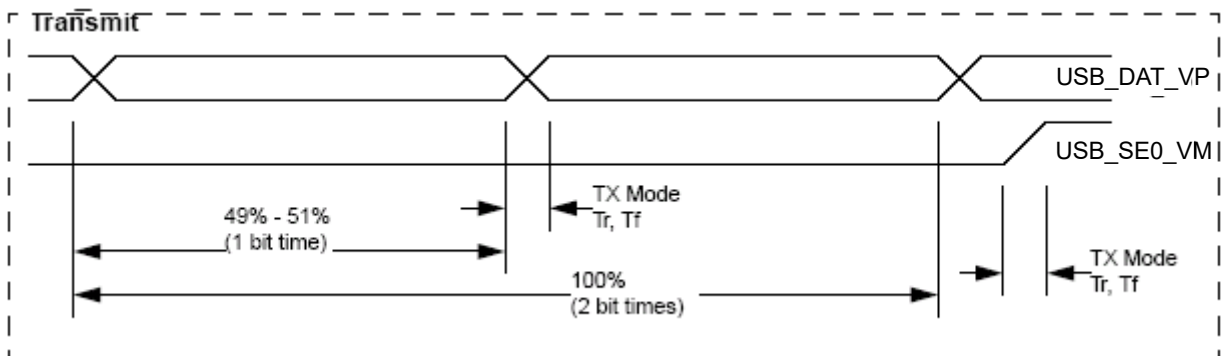

Figure 64. USB Transmit Waveform in DAT_SE0 Bidirectional Mode

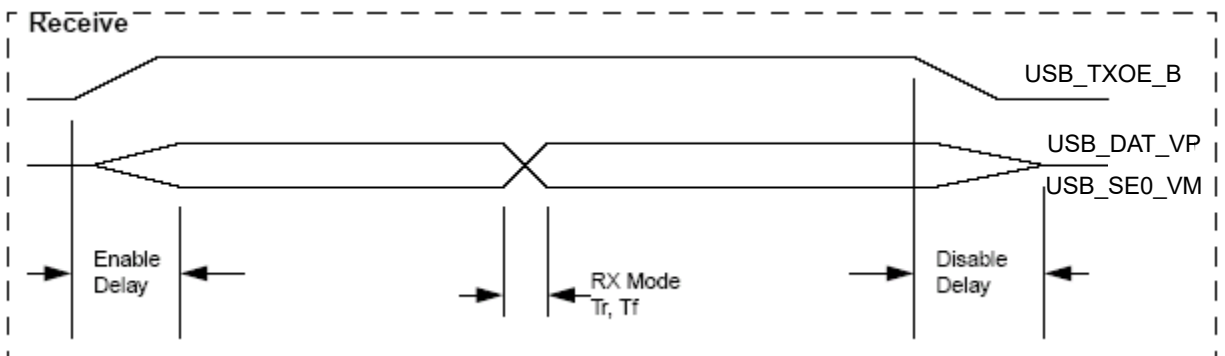

Figure 65. USB Receive Waveform in DAT_SE0 Bidirectional Mode

Table 52. OTG Port Timing Specification in DAT_SE0 Bidirectional Mode

Parameter	Signal Name	Direction	Min	Max	Unit	Conditions/ Reference Signal
TX Rise/Fall Time	USB_DAT_VP	Out	—	5.0	ns	50 pF
TX Rise/Fall Time	USB_SE0_VM	Out	—	5.0	ns	50 pF
TX Rise/Fall Time	USB_TXOE_B	Out	—	5.0	ns	50 pF
TX Duty Cycle	USB_DAT_VP	Out	49.0	51.0	%	—
Enable Delay	USB_DAT_VP USB_SE0_VM	In	—	8.0	ns	USB_TXOE_B
Disable Delay	USB_DAT_VP USB_SE0_VM	In	—	10.0	ns	USB_TXOE_B
RX Rise/Fall Time	USB_DAT_VP	In	—	3.0	ns	35 pF
RX Rise/Fall Time	USB_SE0_VM	In	—	3.0	ns	35 pF

4.3.15.2 DAT_SE0 Unidirectional Mode

Table 53. Signal Definitions—DAT_SE0 Unidirectional Mode

Name	Direction	Signal Description
USB_TXOE_B	Out	Transmit enable, active low
USB_DAT_VP	Out	TX data when USB_TXOE_B is low.
USB_SE0_VM	Out	SE0 drive when USB_TXOE_B is low.
USB_VP1	In	Buffered data on DP when USB_TXOE_B is high.
USB_VM1	In	Buffered data on DM when USB_TXOE_B is high.
USB_RCV	In	Differential RX data when USB_TXOE_B is high.

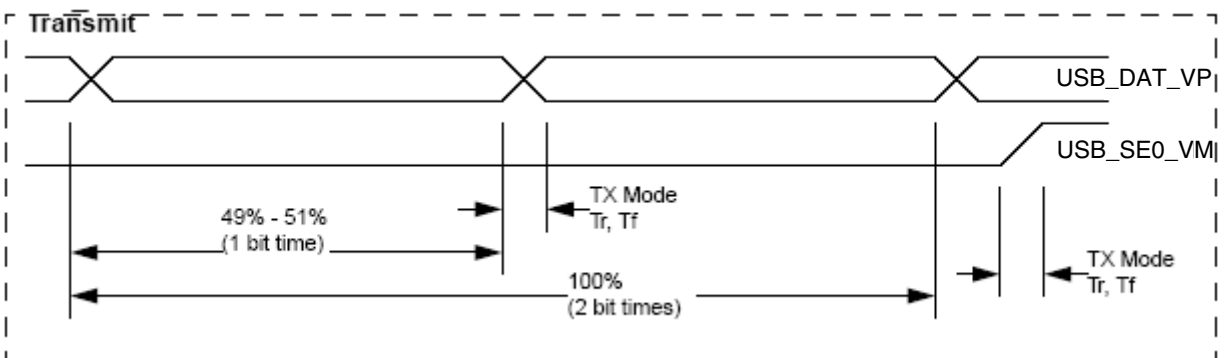

Figure 66. USB Transmit Waveform in DAT_SE0 Unidirectional Mode

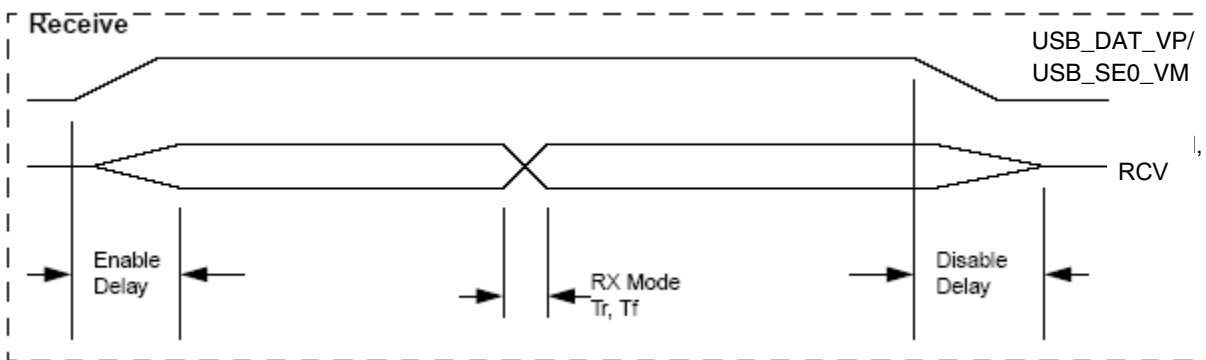

Figure 67. USB Receive Waveform in DAT_SE0 Unidirectional Mode

Table 54. OTG Port Timing Specification in DAT_SE0 Unidirectional Mode

Parameter	Signal Name	Signal Source	Min	Max	Unit	Condition/ Reference Signal
TX Rise/Fall Time	USB_DAT_VP	Out	—	5.0	ns	50 pF
TX Rise/Fall Time	USB_SE0_VM	Out	—	5.0	ns	50 pF
TX Rise/Fall Time	USB_TXOE_B	Out	—	5.0	ns	50 pF
TX Duty Cycle	USB_DAT_VP	Out	49.0	51.0	%	—
Enable Delay	USB_DAT_VP USB_SE0_VM	In	—	8.0	ns	USB_TXOE_B
Disable Delay	USB_DAT_VP USB_SE0_VM	In	—	10.0	ns	USB_TXOE_B
RX Rise/Fall Time	USB_VP1	In	—	3.0	ns	35 pF
RX Rise/Fall Time	USB_VM1	In	—	3.0	ns	35 pF
RX Rise/Fall Time	USB_RCV	In	—	3.0	ns	35 pF

4.3.15.3 VP_VM Bidirectional Mode

Table 55. Signal Definitions—VP_VM Bidirectional Mode

Name	Direction	Signal Description
USB_TXOE_B	Out	<ul style="list-style-type: none"> Transmit enable, active low
USB_DAT_VP	Out (Tx) In (Rx)	<ul style="list-style-type: none"> TX VP data when USB_TXOE_B is low RX VP data when USB_TXOE_B is high
USB_SE0_VM	Out (Tx) In (Rx)	<ul style="list-style-type: none"> TX VM data when USB_TXOE_B low RX VM data when USB_TXOE_B high
USB_RCV	In	<ul style="list-style-type: none"> Differential RX data

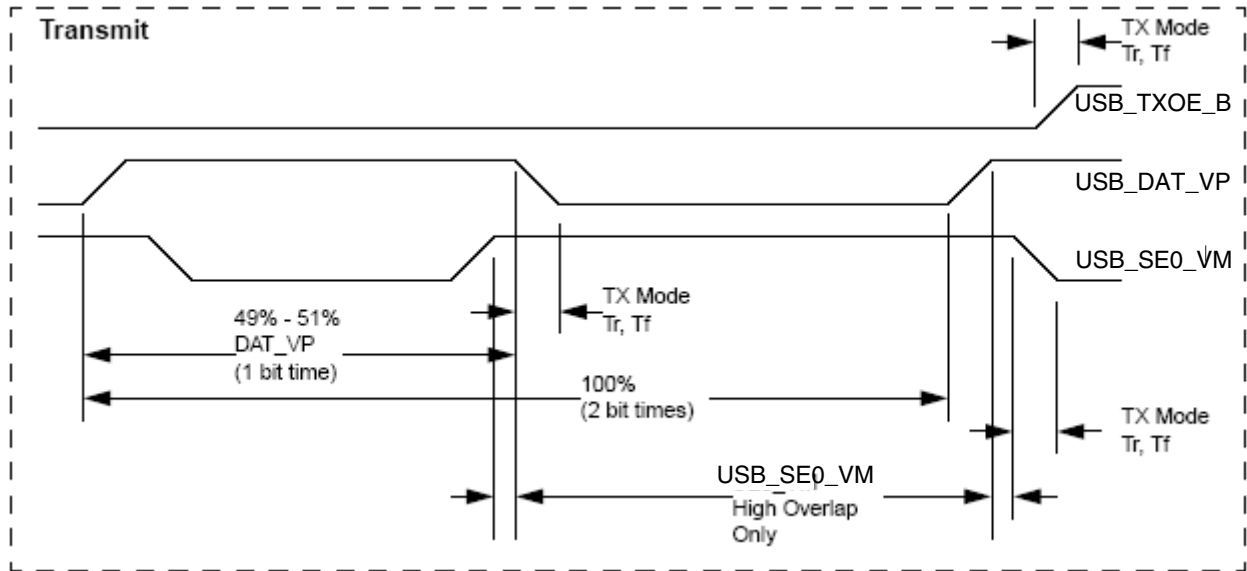

Figure 68. USB Transmit Waveform in VP_VM Bidirectional Mode

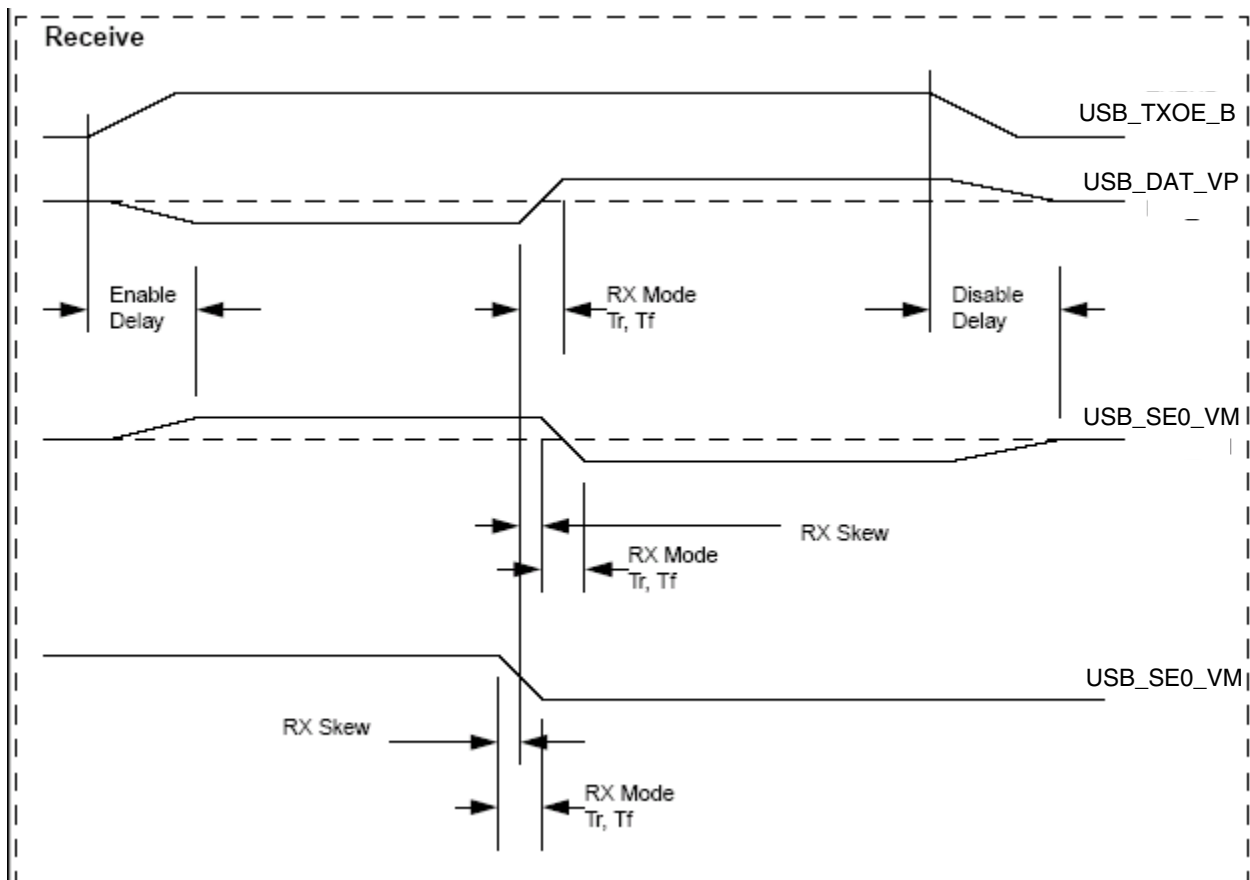

Figure 69. USB Receive Waveform in VP_VM Bidirectional Mode

Table 56. OTG Port Timing Specification in VP_VM Bidirectional Mode

Parameter	Signal Name	Direction	Min	Max	Unit	Condition/ Reference Signal
TX Rise/Fall Time	USB_DAT_VP	Out	—	5.0	ns	50 pF
TX Rise/Fall Time	USB_SE0_VM	Out	—	5.0	ns	50 pF
TX Rise/Fall Time	USB_TXOE_B	Out	—	5.0	ns	50 pF
TX Duty Cycle	USB_DAT_VP	Out	49.0	51.0	%	—
TX High Overlap	USB_SE0_VM	Out	0.0	—	ns	USB_DAT_VP
TX Low Overlap	USB_SE0_VM	Out	—	0.0	ns	USB_DAT_VP
Enable Delay	USB_DAT_VP USB_SE0_VM	In	—	8.0	ns	USB_TXOE_B
Disable Delay	USB_DAT_VP USB_SE0_VM	In	—	10.0	ns	USB_TXOE_B
RX Rise/Fall Time	USB_DAT_VP	In	—	3.0	ns	35 pF
RX Rise/Fall Time	USB_SE0_VM	In	—	3.0	ns	35 pF
RX Skew	USB_DAT_VP	Out	-4.0	+4.0	ns	USB_SE0_VM
RX Skew	USB_RCV	Out	-6.0	+2.0	ns	USB_DAT_VP

4.3.15.4 VP_VM Unidirectional Mode

Table 57. Signal Definitions—VP_VM Unidirectional Mode

Name	Direction	Signal Description
USB_TXOE_B	Out	Transmit enable, active low
USB_DAT_VP	Out	TX VP data when USB_TXOE_B is low
USB_SE0_VM	Out	TX VM data when USB_TXOE_B is low
USB_VP1	In	RX VP data when USB_TXOE_B is high
USB_VM1	In	RX VM data when USB_TXOE_B is high
USB_RCV	In	Differential RX data

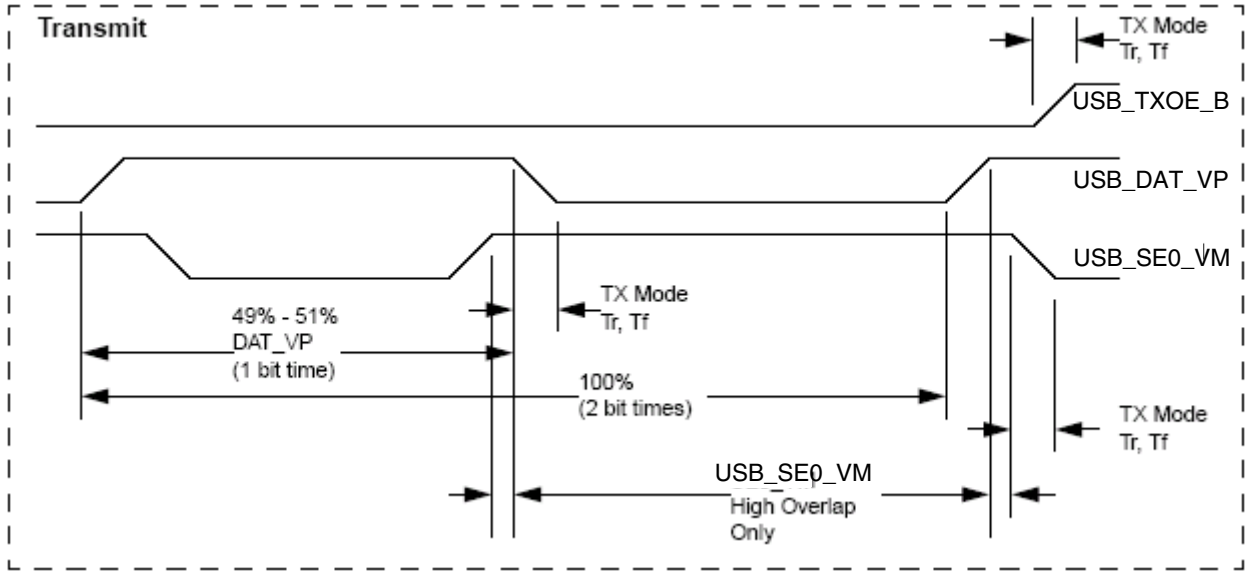

Figure 70. USB Transmit Waveform in VP_VM Unidirectional Mode

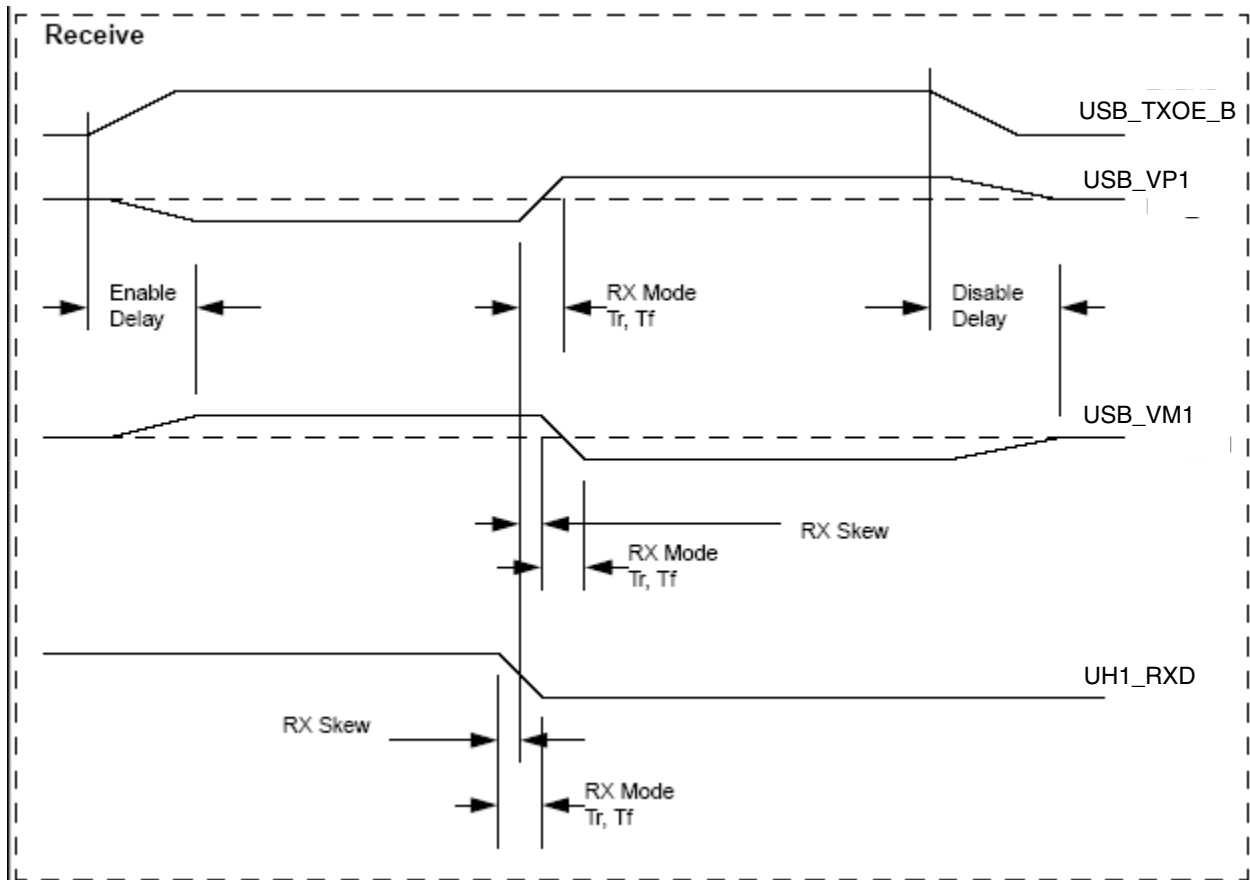

Figure 71. USB Receive Waveform in VP_VM Unidirectional Mode

Table 58. USB Timing Specification in VP_VM Unidirectional Mode

Parameter	Signal	Direction	Min	Max	Unit	Conditions/ Reference Signal
TX Rise/Fall Time	USB_DAT_VP	Out	—	5.0	ns	50 pF
TX Rise/Fall Time	USB_SE0_VM	Out	—	5.0	ns	50 pF
TX Rise/Fall Time	USB_TXOE_B	Out	—	5.0	ns	50 pF
TX Duty Cycle	USB_DAT_VP	Out	49.0	51.0	%	—
TX High Overlap	USB_SE0_VM	Out	0.0	—	ns	USB_DAT_VP
TX Low Overlap	USB_SE0_VM	Out	—	0.0	ns	USB_DAT_VP
Enable Delay	USB_DAT_VP USB_SE0_VM	In	—	8.0	ns	USB_TXOE_B
Disable Delay	USB_DAT_VP USB_SE0_VM	In	—	10.0	ns	USB_TXOE_B
RX Rise/Fall Time	USB_VP1	In	—	3.0	ns	35 pF
RX Rise/Fall Time	USB_VM1	In	—	3.0	ns	35 pF
RX Skew	USB_VP1	Out	-4.0	+4.0	ns	USB_SE0_VM
RX Skew	USB_RCV	Out	-6.0	+2.0	ns	USB_DAT_VP

5 Package Information and Pinout

The i.MX27/MX27L processor is available in a 17 mm × 17 mm, 0.65 mm pitch, 404-pin MAPBGA package and a 19 mm × 19 mm, 0.8 mm pitch, 473-pin MAPBGA package.

5.1 Package Outline Drawing (17 mm × 17 mm–404 pin)

Figure 72 through Figure 76 show the package drawings and dimensions of the production package.

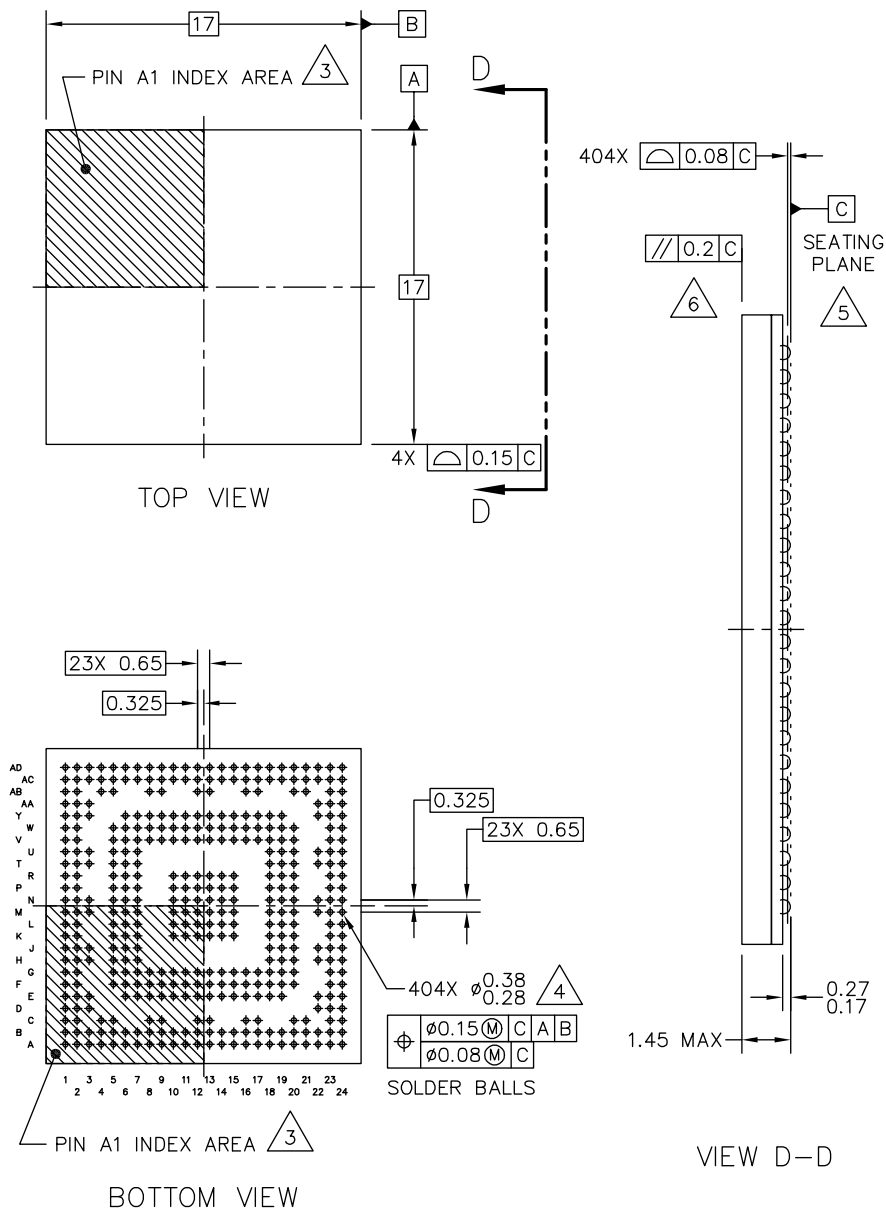
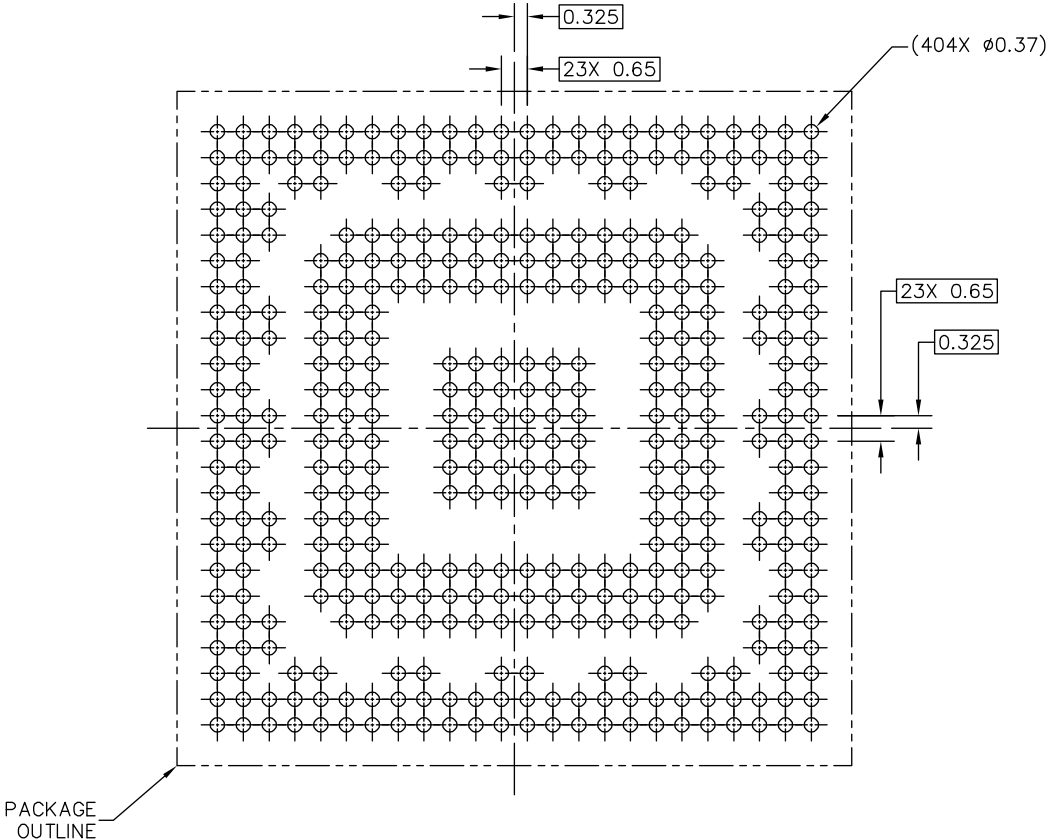

Figure 72. i.MX27/MX27L 17 mm × 17 mm MAPBGA: Mechanical Drawing (sheet 1 of 5)



PCB DESIGN GUIDELINES – SOLDER MASK OPENING PATTERN

THIS SHEET SERVES ONLY AS A GUIDELINE TO HELP DEVELOP A USER SPECIFIC SOLUTION. DEVELOPMENT EFFORT WILL STILL BE REQUIRED BY END USERS TO OPTIMIZE PCB MOUNTING PROCESSES AND BOARD DESIGN IN ORDER TO MEET INDIVIDUAL/SPECIFIC REQUIREMENTS.

Figure 73. i.MX27/MX27L 17 mm x 17 mm MAPBGA: Mechanical Drawing (Sheet 2 of 5)

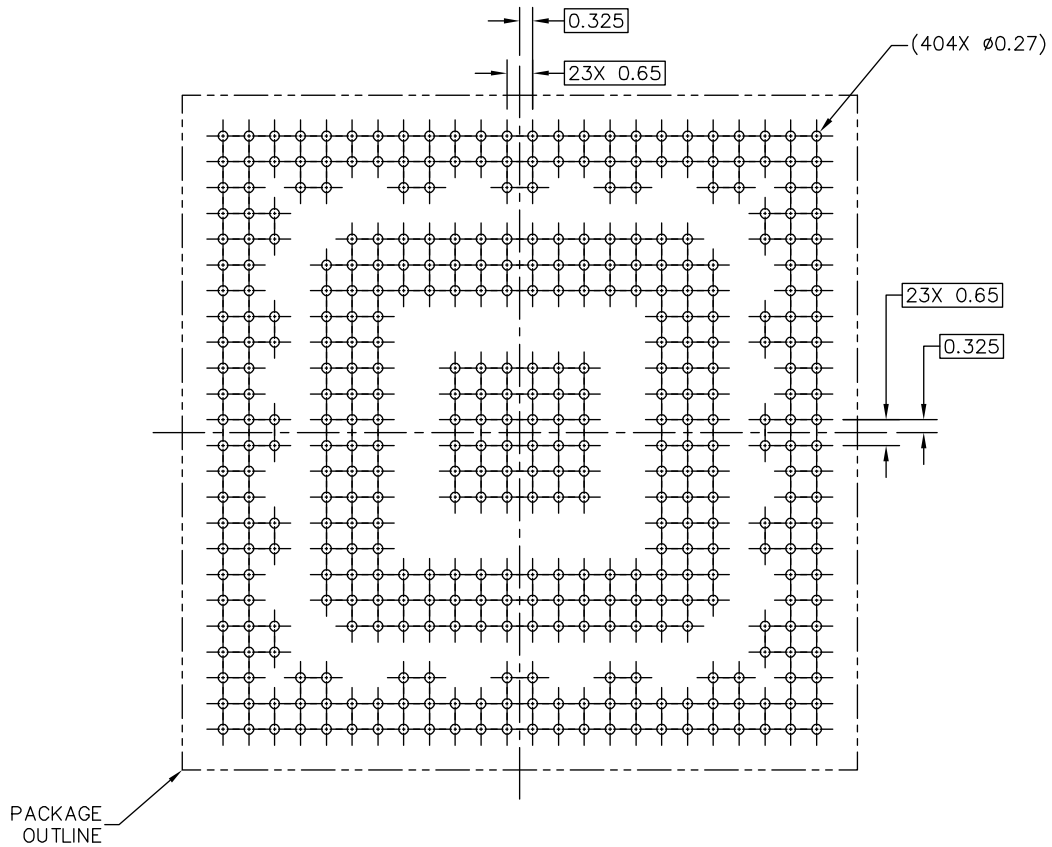

PCB DESIGN GUIDELINES – I/O PADS AND SOLDERABLE AREA

THIS SHEET SERVES ONLY AS A GUIDELINE TO HELP DEVELOP A USER SPECIFIC SOLUTION. DEVELOPMENT EFFORT WILL STILL BE REQUIRED BY END USERS TO OPTIMIZE PCB MOUNTING PROCESSES AND BOARD DESIGN IN ORDER TO MEET INDIVIDUAL/SPECIFIC REQUIREMENTS.

Figure 74. i.MX27/MX27L 17 mm x 17 mm MAPBGA: Mechanical Drawing (Sheet 3 of 5)

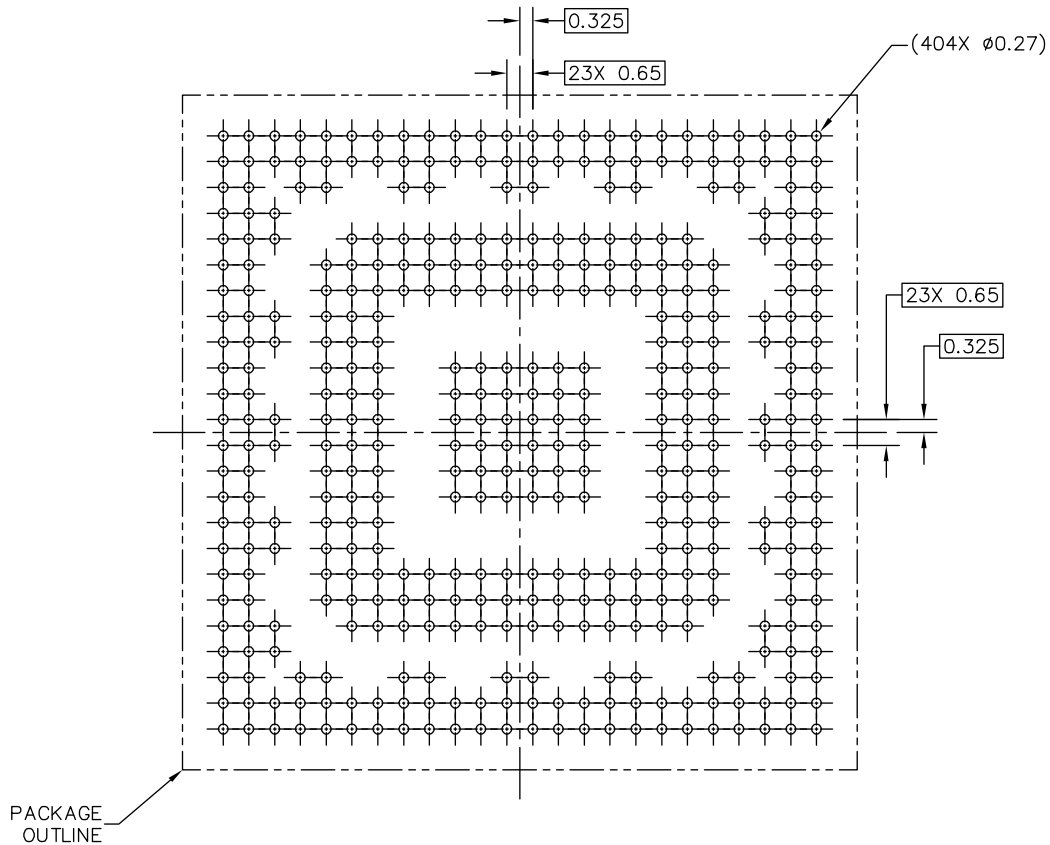

RECOMMENDED STENCIL THICKNESS 0.1

PCB DESIGN GUIDELINES – SOLDER PASTE STENCIL

THIS SHEET SERVES ONLY AS A GUIDELINE TO HELP DEVELOP A USER SPECIFIC SOLUTION. DEVELOPMENT EFFORT WILL STILL BE REQUIRED BY END USERS TO OPTIMIZE PCB MOUNTING PROCESSES AND BOARD DESIGN IN ORDER TO MEET INDIVIDUAL/SPECIFIC REQUIREMENTS.

Figure 75. i.MX27/MX27L 17 mm × 17 mm MAPBGA: Mechanical Drawing (Sheet 4 of 5)

NOTES:

1. ALL DIMENSIONS IN MILLIMETERS.
2. DIMENSIONING AND TOLERANCING PER ASME Y14.5M-1994.
3. PIN A1 FEATURE SHAPE, SIZE AND LOCATION MAY VARY.
4. MAXIMUM SOLDER BALL DIAMETER MEASURED PARALLEL TO DATUM C.
5. DATUM C, THE SEATING PLANE, IS DETERMINED BY THE SPHERICAL CROWNS OF THE SOLDER BALLS.
6. PARALLELISM MEASUREMENT SHALL EXCLUDE ANY EFFECT OF MARK ON TOP SURFACE OF PACKAGE.

Figure 76. i.MX27/MX27L 17 mm × 17 mm MAPBGA: Mechanical Drawing (Sheet 5 of 5)

5.2 Pin Assignments (17 mm × 17 mm–404 pin)

[Table 59](#) identifies the i.MX27 (17 mm × 17 mm) MAPBGA package pin assignments.

[Table 60](#) provides the pin assignments listed by contact name—that is, the list is sorted alphabetically by the name of the contact. The connections of these pins depend solely upon the user application, however there are a few factory test signals that are not used in a normal application. Following is a list of these signals and how they are to be terminated for proper operation of the i.MX27/MX27L processor:

- CLKMODE[1:0]: To ensure proper operation, leave these signals as no connects.
- OSC26M_TEST: To ensure proper operation, leave this signal as no connect.
- EXT_60M: To ensure proper operation, connect this signal to ground.
- EXT_266M: To ensure proper operation, connect this signal to ground.
- Most of the signals shown in [Table 59](#) are multiplexed with other signals. For ease of reference, all of the signals at a particular pad are shown in the form of a compound signal name. Please refer to [Table 3](#) for complete information on the signal multiplexing schemes of these signals.

Table 59. i.MX27 (17 mm × 17 mm) MAPBGA Pin Assignments

19	RTCK_OWIRE _PE16	TMS			USBH1_FS_UART4 _RTS_PB26	19
18	UART1_CTS_PE14	TDI			SD1_D3_CSPI3 _SS_PE21	18
17	UART3_CTS_ PE10	UART1_TXD _PE12	TRST_B		SD1_D1_PE19	17
16	UART2_TXD_KP _COL6_PE6	UART3_TXD _PE8	UART1_RTS_PE15		TDO	16
15	KP_COL2	KP_COL4			UART3_RTS_PE11	15
14	UART2_RTS_KP _ROW7_PE4	KP_COLO			UART2_RXD_KP _ROW6_PE7	14
13	KP_ROW5	I2C_CLK_PD18	PWMO_PE5		KP_COL3	13
12	KP_ROW1	KP_ROW3	KP_ROW2		UART2_CTS_KP _COL7_PE3	12
11	SSI3_RXDAT_SLDCDC2 _RS_PC29	SSI3_CLK_ SLCDC2CLK_PC31			KP_ROW4	11
10	SSI2_RXDAT_GPT5 _TIN_PC25	SSI2_CLK_GPT4 _TIN_PC27			SSI3_FS_SLDCDC2 _D0_PC28	10
9	SSI1_RXDAT _PC21	SSI1_CLK_PC23	SSI3_TXDAT_ SLCDC2_CS_PC30		SSI1_TXDAT_PC22	9
8	SSI4_RXDAT _PC17	SSI4_CLK _PC19	SD2_D2_MSHC _DATA2_PB6		TOUT_PC14	8
7	CSI_HSYNC_ UART5_RTS_PB21	TIN_PC15			CSI_PIXCLK_PB16	7
6	CSI_D5_PB17	CSI_D7_UART5 _RXD_PB19			CSI_D2_UART6 _CTS_PB12	6
5	CSI_D3_UART6_ RTS_PB13	CSI_MCLK_PB15	SD2_CMD_MSHC _BS_PB8			5
4	SD2_CLK_MSHC _SCLK_PB9	CSI_D1_UART6 _RXD_PB11	CSI_D0_UART6 _TXD_PB10			4
3	SD2_D3_MSHC _DATA3_PB7	SPL_SPR_PA27		OE_ACD_PA31	SD2_D1_MSHC _DATA1_PB5	3
2	GND	GND	CONTRAST _PA30	PS_PA26	LD16_PA22	2
1	GND	GND	SD2_D0_MSHC _DATA0_PB4	HSYNC_PA28	REV_PA24	1
	A	B	C	D	E	

i.MX27 and i.MX27L Data Sheet, Rev. 2, 3/2019

Table 59. i.MX27 (17 mm × 17 mm) MAPBGA Pin Assignments (continued)

19	USBH1_TXDM_UART4_TXD_PB28	USBH1_SUSP_PB22	USBOTG_DATA5_PC7	USBOTG_DATA0_PC9	RTCVDD	19
18	CSPI1_SCLK_PD29	USBOTG_DATA1_PC11	NVDD14	UPLLVD	RTCVSS	18
17	TCK	SD1_CLK_CSPI3_SCLK_PE23				17
16	UART1_RXD_PE13					16
15	UART3_RXD_PE9	NVDD8			GND	15
14	KP_COL5	NVDD9			GND	14
13	KP_COL1	QVDD			GND	13
12	I2C_DATA_PD17	QVDD			GND	12
11	KP_ROW0	NVDD10			GND	11
10	SSI2_TXDAT_GPT4_TOUT_PC26	NVDD11			GND	10
9	SSI1_FS_PC20	SSI2_FS_GPT5_TOUT_PC24				9
8	SSI4_FS_PC16	SSI4_TXDAT_PC18				8
7	CSI_D6_UART5_TXD_PB18	CSI_VSYNC_UART5_CTS_PB20	NVDD15	LD11_PA17	LD9_PA15	7
6	CSI_D4_PB14	CLS_PA25	LD15_PA21	LD5_PA11	LD1_PA7	6
5	VSYNC_PA29	LD17_PA23	LD13_PA19	LD7_PA13	LD3_PA9	5
4						4
3			LD12_PA18	LD2_PA8		3
2	LD10_PA16	LD6_PA12	LD4_PA10	LD0_PA6	LSCLK_PA5	2
1	LD14_PA20	LD8_PA14	NFRB_ETMTRACEPKT3_PFO	NFWP_B_ETMTRACEPKT1_PFO	NFALE_ETMPIPE_STATO_PFO	1
	F	G	H	J	K	

Table 59. i.MX27 (17 mm × 17 mm) MAPBGA Pin Assignments (continued)

19	NVDD7	NVDD13	POWER_ON_RESET	ATA_DATA6_FEC_MDIO_PD8	FUSEVSS	19
18	NVDD7	FPMVDD	NVDD6	NVDD6	FUSEVDD	18
17						17
16						16
15	GND	UPLLVS	GND	FPMVSS	MPLLVS	15
14	GND	GND	GND	GND	GND	14
13	GND	GND	GND	GND	GND	13
12	GND	GND	GND	GND	GND	12
11	GND	GND	GND	GND	GND	11
10	GND	GND	GND	GND	GND	10
9						9
8						8
7	NVDD12	NVDD1	NVDD1	QVDD	NVDD2	7
6	NFCLE_ETMTRAC EPKT0_P1	D9	D1	A12	A7	6
5	NFRE_B_ETMPIP ESTAT1_P5	D13	D3	A9	A5	5
4						4
3		D11	D5			3
2	NFCE_B_ETMTRACE PKT2_P3	D15	D7	D8	D4	2
1	NFWE_B_ETMPIP STAT2_P6	D14	D12	D10	D6	1
	L	M	N	P	R	

Table 59. i.MX27 (17 mm × 17 mm) MAPBGA Pin Assignments (continued)

19	AVSS	BOOT2	OSC26M_TEST	PC_VS2_ATA _DA0_P13	PC_PWRON_ATA _DA2_P16	19
18	MPLLVD	AVDD	NVDD5	PC_CD1_B_ATA _DIOR_P20	PC_WAIT_B_ATA _CS1_P18	18
17			NVDD5	EXT_60M	OE_B	17
16			QVDD	EB0_B	LBA_B	16
15			QVDD	CS5_B_ETMTRACE CLK_P22	CS2_B	15
14			QVDD	CS3_B	SDCKE1	14
13			NVDD4	SDWE_B	DQM2	13
12			NVDD3	DQM1	SD2	12
11			NVDD3	A16	A15	11
10			NVDD2	SD6	SD8	10
9			NVDD2	SD13	SD12	9
8			A19	SDQS1	SD15	8
7	NVDD2	NVDD2	SD29	SD25	SD18	7
6	A1	A25	SD28	SDQS2	A20	6
5	SDBA1	SD31	SD26	SD23		5
4						4
3	MA10	A3			SDQS3	3
2	D0	A11	A6	A2	SDBA0	2
1	D2	A13	A8	A4	A0	1
	T	U	V	W	Y	

Table 59. i.MX27 (17 mm × 17 mm) MAPBGA Pin Assignments (continued)

	AA	AB	AC	AD	
1	SD30	A23	GND	GND	1
2	A24	SD24	GND	GND	2
3	SD27		A22	SD22	3
4		A21	SD20	SD19	4
5		SD21	SD17	SD16	5
6			A18	SD14	6
7			A17	SD11	7
8		SD10	SD9	SD7	8
9		A14	SD5	SDQS0	9
10			SD4	SD3	10
11			SD1	DQM3	11
12		SD0	A10	DQM0	12
13		RAS_B	CAS_B	SDCLK	13
14			SDCKE0	SDCLK_B	14
15			RW_B	CS4_B_ETMTRACE SYNC_PF21	15
16		CS1_B	ECB_B	CS0_B	16
17		BCLK	EB1_B	CLKO_PF15	17
18			JTAG_CTRL	EXT_266M	18
19			PC_CD2_B_ATA _DIOW_PF19	PC_READY_ATA _CS0_PF17	19

Table 60 shows the device pin list, sorted by signal identification, including pad locations for ground and power supply voltages.

Table 60. i.MX27 (17 mm × 17 mm) MAPBGA Contact Name Listing

Contact Name	Location
A0	Y1
A1	T6
A10	AC12
A11	U2
A12	P6
A13	U1
A14	AB9
A15	Y11
A16	W11
A17	AC7
A18	AC6
A19	V8
A2	W2
A20	Y6
A21	AB4
A22	AC3
A23	AB1
A24	AA2
A25	U6
A3	U3
A4	W1
A5	R5
A6	V2
A7	R6
A8	V1
A9	P5
ATA_DATA0_SD3_D0_PD2	R23
ATA_DATA1_SD3_D1_PD3	R24
ATA_DATA10_ETMTRACEPKT9_PD12	R20
ATA_DATA11_ETMTRACEPKT8_PD13	W23
ATA_DATA12_ETMTRACEPKT7_PD14	U23

Table 60. i.MX27 (17 mm × 17 mm) MAPBGA Contact Name Listing (continued)

Contact Name	Location
ATA_DATA13_ETMTRACEPKT6_PD15	W24
ATA_DATA14_ETMTRACEPKT5_PD16	T20
ATA_DATA15_ETMTRACEPKT4_PF23	Y24
ATA_DATA2_SD3_D2_PD4	P20
ATA_DATA3_SD3_D3_PD5	T24
ATA_DATA4_ETMTRACEPKT14_PD6	T22
ATA_DATA5_ETMTRACEPKT13_PD7	T23
ATA_DATA6_FEC_MDIO_PD8	P19
ATA_DATA7_ETMTRACEPKT12_PD9	U24
ATA_DATA8_ETMTRACEPKT11_PD10	U22
ATA_DATA9_ETMTRACEPKT10_PD11	V24
AVDD	U18
AVSS	T19
BCLK	AB17
BOOT0	V23
BOOT1	Y23
BOOT2	U19
BOOT3	Y22
CAS_B	AC13
CLKMODE0	AB20
CLKMODE1	AB21
CLKO_PF15	AD17
CLS_PA25	G6
CONTRAST_PA30	C2
CS0_B	AD16
CS1_B	AB16
CS2_B	Y15
CS3_B	W14
CS4_B_ETMTRACESYNC_PF21	AD15
CS5_B_ETMTRACECLK_PF22	W15
CSI_D0_UART6_TXD_PB10	C4
CSI_D1_UART6_RXD_PB11	B4
CSI_D2_UART6_CTS_PB12	E6

Table 60. i.MX27 (17 mm × 17 mm) MAPBGA Contact Name Listing (continued)

Contact Name	Location
CSI_D3_UART6_RTS_PB13	A5
CSI_D4_PB14	F6
CSI_D5_PB17	A6
CSI_D6_UART5_TXD_PB18	F7
CSI_D7_UART5_RXD_PB19	B6
CSI_HSYNC_UART5_RTS_PB21	A7
CSI_MCLK_PB15	B5
CSI_PIXCLK_PB16	E7
CSI_VSYNC_UART5_CTS_PB20	G7
CSPI1_MISO_PD30	A22
CSPI1_MOSI_PD31	C21
CSPI1_RDY_PD25	B21
CSPI1_SCLK_PD29	F18
CSPI1_SS0_PD28	B22
CSPI1_SS1_PD27	C20
CSPI1_SS2_USBH2_DATA5_PD26	E22
CSPI2_MISO_USBH2_DATA2_PD23	G20
CSPI2_MOSI_USBH2_DATA1_PD24	E23
CSPI2_SCLK_USBH2_DATA0_PD22	D23
CSPI2_SS0_USBH2_DATA6_PD21	F20
CSPI2_SS1_USBH2_DATA3_PD20	C23
CSPI2_SS2_USBH2_DATA4_PD19	D22
D0	T2
D1	N6
D10	P1
D11	M3
D12	N1
D13	M5
D14	M1
D15	M2
D2	T1
D3	N5
D4	R2

Table 60. i.MX27 (17 mm × 17 mm) MAPBGA Contact Name Listing (continued)

Contact Name	Location
D5	N3
D6	R1
D7	N2
D8	P2
D9	M6
DQM0	AD12
DQM1	W12
DQM2	Y13
DQM3	AD11
EB0_B	W16
EB1_B	AC17
ECB_B	AC16
EXT_266M	AD18
EXT_60M	W17
EXTAL26M	AB24
EXTAL32K	M24
FPMVDD	M18
FPMVSS	P15
FUSEVDD	R18
FUSEVSS	R19
GND	A1
GND	A2
GND	A23
GND	A24
GND	AC1
GND	AC2
GND	AC23
GND	AC24
GND	AD1
GND	AD2
GND	AD23
GND	AD24
GND	B1

Table 60. i.MX27 (17 mm × 17 mm) MAPBGA Contact Name Listing (continued)

Contact Name	Location
GND	B2
GND	B23
GND	B24
GND	K10
GND	K11
GND	K12
GND	K13
GND	K14
GND	K15
GND	L10
GND	L11
GND	L12
GND	L13
GND	L14
GND	L15
GND	M10
GND	M11
GND	M12
GND	M13
GND	M14
GND	N10
GND	N11
GND	N12
GND	N13
GND	N14
GND	N15
GND	P10
GND	P11
GND	P12
GND	P13
GND	P14
GND	R10
GND	R11

Table 60. i.MX27 (17 mm × 17 mm) MAPBGA Contact Name Listing (continued)

Contact Name	Location
GND	R12
GND	R13
GND	R14
HSYNC_PA28	D1
I2C_CLK_PD18	B13
I2C_DATA_PD17	F12
I2C2_SCL_PC6	F24
I2C2_SDA_PC5	J22
IOIS16_ATA_INTRQ_PF9	U20
JTAG_CTRL	AC18
KP_COL0	B14
KP_COL1	F13
KP_COL2	A15
KP_COL3	E13
KP_COL4	B15
KP_COL5	F14
KP_ROW0	F11
KP_ROW1	A12
KP_ROW2	C12
KP_ROW3	B12
KP_ROW4	E11
KP_ROW5	A13
LBA_B	Y16
LD0_PA6	J2
LD1_PA7	K6
LD10_PA16	F2
LD11_PA17	J7
LD12_PA18	H3
LD13_PA19	H5
LD14_PA20	F1
LD15_PA21	H6
LD16_PA22	E2
LD17_PA23	G5

Table 60. i.MX27 (17 mm × 17 mm) MAPBGA Contact Name Listing (continued)

Contact Name	Location
LD2_PA8	J3
LD3_PA9	K5
LD4_PA10	H2
LD5_PA11	J6
LD6_PA12	G2
LD7_PA13	J5
LD8_PA14	G1
LD9_PA15	K7
LSCLK_PA5	K2
MA10	T3
MPLLVD	T18
MPLLVS	R15
NFALE_ETMPIPESTAT0_P4	K1
NFCE_B_ETMTRACEPKT2_P3	L2
NFCLE_ETMTRACEPKT0_P1	L6
NFRB_ETMTRACEPKT3_P0	H1
NFRE_B_ETMPIPESTAT1_P5	L5
NFWE_B_ETMPIPESTAT2_P6	L1
NFWP_B_ETMTRACEPKT1_P2	J1
NVDD1	M7
NVDD1	N7
NVDD10	G11
NVDD11	G10
NVDD12	L7
NVDD13	M19
NVDD14	H18
NVDD15	H7
NVDD2	R7
NVDD2	T7
NVDD2	U7
NVDD2	V10
NVDD2	V9
NVDD3	V11

Table 60. i.MX27 (17 mm × 17 mm) MAPBGA Contact Name Listing (continued)

Contact Name	Location
NVDD3	V12
NVDD4	V13
NVDD5	V17
NVDD5	V18
NVDD6	N18
NVDD6	P18
NVDD7	L18
NVDD7	L19
NVDD8	G15
NVDD9	G14
OE_ACD_PA31	D3
OE_B	Y17
OSC26M_TEST	V19
OSC26VDD	AA23
OSC26VSS	AB23
OSC32K_BYPASS	L24
OSC32VDD	M23
OSC32VSS	N23
PC_BVD1_ATA_DMARQ_PF12	AD20
PC_BVD2_ATA_DMACK_PF11	W20
PC_CD1_B_ATA_DIOR_PF20	W18
PC_CD2_B_ATA_DIOW_PF19	AC19
PC_POE_ATA_BUFFER_EN_PF7	V20
PC_PWRON_ATA_DA2_PF16	Y19
PC_READY_ATA_CS0_PF17	AD19
PC_RST_ATA_RESET_B_PF10	AC21
PC_RW_B_ATA_IORDY_PF8	AD21
PC_VS1_ATA_DA1_PF14	AC20
PC_VS2_ATA_DA0_PF13	W19
PC_WAIT_B_ATA_CS1_PF18	Y18
POR_B	AD22
POWER_CUT	N22
POWER_ON_RESET	N19

Table 60. i.MX27 (17 mm × 17 mm) MAPBGA Contact Name Listing (continued)

Contact Name	Location
PS_PA26	D2
PWMO_PE5	C13
QVDD	G12
QVDD	G13
QVDD	G16
QVDD	P7
QVDD	V14
QVDD	V15
QVDD	V16
RAS_B	AB13
RESET_IN_B	AC22
RESET_OUT_B_PE17	AA22
REV_PA24	E1
RTCK_OWIRE_PE16	A19
RTCVDD	K19
RTCVSS	K18
RW_B	AC15
SD0	AB12
SD1	AC11
SD1_CLK_CSPI3_SCLK_PE23	G17
SD1_CMD_CSPI3_MOSI_PE22	A21
SD1_D0_CSPI3_MISO_PE18	A20
SD1_D1_PE19	E17
SD1_D2_PE20	B20
SD1_D3_CSPI3_SS_PE21	E18
SD10	AB8
SD11	AD7
SD12	Y9
SD13	W9
SD14	AD6
SD15	Y8
SD16	AD5
SD17	AC5

Table 60. i.MX27 (17 mm × 17 mm) MAPBGA Contact Name Listing (continued)

Contact Name	Location
SD18	Y7
SD19	AD4
SD2	Y12
SD2_CLK_MSHC_SCLK_PB9	A4
SD2_CMD_MSHC_BS_PB8	C5
SD2_D0_MSHC_DATA0_PB4	C1
SD2_D1_MSHC_DATA1_PB5	E3
SD2_D2_MSHC_DATA2_PB6	C8
SD2_D3_MSHC_DATA3_PB7	A3
SD20	AC4
SD21	AB5
SD22	AD3
SD23	W5
SD24	AB2
SD25	W7
SD26	V5
SD27	AA3
SD28	V6
SD29	V7
SD3	AD10
SD3_CLK_ETMTRACEPKT15_PD1	P24
SD3_CMD_PD0	P23
SD30	AA1
SD31	U5
SD4	AC10
SD5	AC9
SD6	W10
SD7	AD8
SD8	Y10
SD9	AC8
SDBA0	Y2
SDBA1	T5
SDCKE0	AC14

Table 60. i.MX27 (17 mm × 17 mm) MAPBGA Contact Name Listing (continued)

Contact Name	Location
SDCKE1	Y14
SDCLK	AD13
SDCLK_B	AD14
SDQS0	AD9
SDQS1	W8
SDQS2	W6
SDQS3	Y3
SDWE_B	W13
SPL_SPR_PA27	B3
SSI1_CLK_PC23	B9
SSI1_FS_PC20	F9
SSI1_RXDAT_PC21	A9
SSI1_TXDAT_PC22	E9
SSI2_CLK_GPT4_TIN_PC27	B10
SSI2_FS_GPT5_TOUT_PC24	G9
SSI2_RXDAT_GPT5_TIN_PC25	A10
SSI2_TXDAT_GPT4_TOUT_PC26	F10
SSI3_CLK_SLCDC2_CLK_PC31	B11
SSI3_FS_SLCDC2_D0_PC28	E10
SSI3_RXDAT_SLCDC2_RS_PC29	A11
SSI3_TXDAT_SLCDC2_CS_PC30	C9
SSI4_CLK_PC19	B8
SSI4_FS_PC16	F8
SSI4_RXDAT_PC17	A8
SSI4_TXDAT_PC18	G8
TCK	F17
TDI	B18
TDO	E16
TIN_PC15	B7
TMS	B19
TOUT_PC14	E8
TRST_B	C17
UART1_CTS_PE14	A18

Table 60. i.MX27 (17 mm × 17 mm) MAPBGA Contact Name Listing (continued)

Contact Name	Location
UART1_RTS_PE15	C16
UART1_RXD_PE13	F16
UART1_TXD_PE12	B17
UART2_CTS_KP_COL7_PE3	E12
UART2_RTS_KP_ROW7_PE4	A14
UART2_RXD_KP_ROW6_PE7	E14
UART2_TXD_KP_COL6_PE6	A16
UART3_CTS_PE10	A17
UART3_RTS_PE11	E15
UART3_RXD_PE9	F15
UART3_TXD_PE8	B16
UPLLVD	J18
UPLLVSS	M15
USB_OC_B_PB24	H20
USB_PWR_PB23	F23
USBH1_FS_UART4_RTS_PB26	E19
USBH1_OE_B_PB27	C24
USBH1_RCV_PB25	H22
USBH1_RXDM_PB30	J20
USBH1_RXDP_UART4_RXD_PB31	E24
USBH1_SUSP_PB22	G19
USBH1_TXDM_UART4_TXD_PB28	F19
USBH1_TXDP_UART4_CTS_PB29	D24
USBH2_CLK_PA0	H23
USBH2_DATA7_PA2	J24
USBH2_DIR_PA1	K23
USBH2_NXT_PA3	L20
USBH2_STP_PA4	J23
USBOTG_CLK_PE24	K24
USBOTG_DATA0_PC9	J19
USBOTG_DATA1_PC11	G18
USBOTG_DATA2_PC10	G23
USBOTG_DATA3_PC13	K20

Table 60. i.MX27 (17 mm × 17 mm) MAPBGA Contact Name Listing (continued)

Contact Name	Location
USBOTG_DATA4_PC12	H24
USBOTG_DATA5_PC7	H19
USBOTG_DATA6_PC8	G24
USBOTG_DATA7_PE25	M22
USBOTG_DIR_KP_ROW7A_PE2	N20
USBOTG_NXT_KP_COL6A_PE0	M20
USBOTG_STP_KP_ROW6A_PE1	L23
VSYNC_PA29	F5
XTAL26M	AA24
XTAL32K	N24

5.3 Package Outline Drawing (19 mm × 19 mm–473 pin)

Figure 77 shows the package drawings and dimensions of the production package.

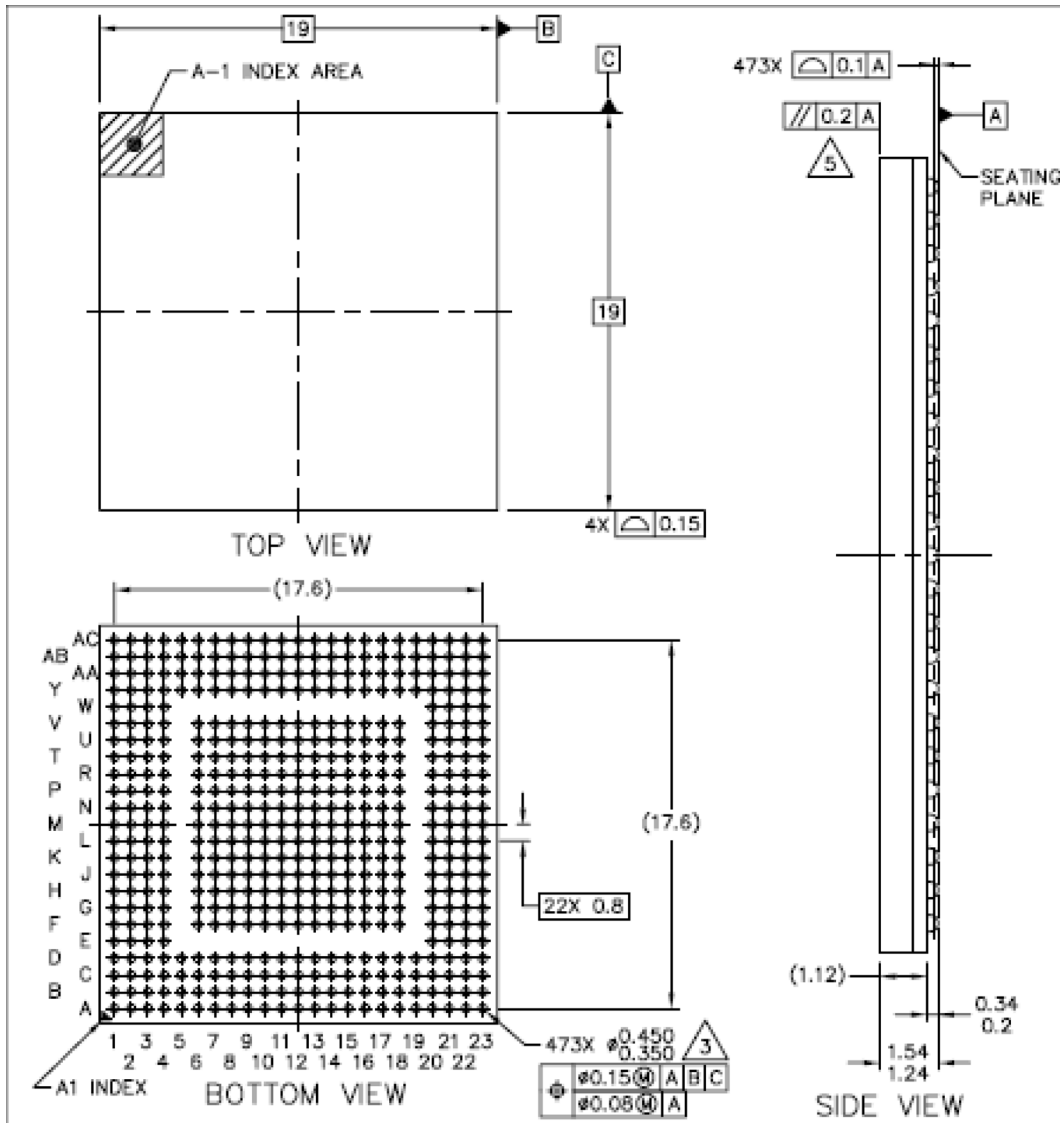

Figure 77. i.MX27/MX27L (19 mm × 19 mm) MAPBGA: Mechanical Drawing

5.4 Pin Assignments (19 mm × 19 mm–473 pin)

[Table 61](#) identifies the i.MX27 (19 mm × 19 mm) MAPBGA package pin assignments.

[Table 62](#) provides the pin assignments listed by contact name—that is, the list is sorted alphabetically by the name of the contact. The connections of these pins depend solely upon the user application, however there are a few factory test signals that are not used in a normal application. Following is a list of these signals and how they are to be terminated for proper operation of the i.MX27/MX27L processor:

- CLKMODE[1:0]: To ensure proper operation, leave these signals as no connects.
- OSC26M_TEST: To ensure proper operation, leave this signal as no connect.
- EXT_60M: To ensure proper operation, connect this signal to ground.
- EXT_266M: To ensure proper operation, connect this signal to ground.
- Most of the signals shown in [Table 62](#) are multiplexed with other signals. For ease of reference, all of the signals at a particular pad are shown in the form of a compound signal name. Refer to [Table 3](#) for complete information on the signal multiplexing schemes of these signals.

Table 61. i.MX27 (19 mm × 19 mm) MAPBGA Pin Assignments

18	RTCK_OWIRE _PE16	SD1_D0_CSPI3 _MISO_PE18	TMS	SD1_D3_CSPI3 _SS_PE21		18
17	UART1_RXD _PE13	UART1_CTS _PE14	UART1_RTS_ PE15	TDI		17
16	UART3_TXD _PE8	UART3_CTS _PE10	UART3_RTS_ PE11	TDO		16
15	KP_COL4	KP_COL5	UART2_RXD_KP_ ROW6_PE7	UART1_TXD_PE12		15
14	PWMO_PE5	KP_COL2	KP_COL3	UART2_TXD_KP_ COL6_PE6		14
13	UART2_CTS_KP _COL7_PE3	I2C_CLK_ PD18	UART2_RTS_KP_ ROW7_PE4	KP_COL0		13
12	KP_ROW3	KP_ROW2	KP_ROW4	KP_ROW5		12
11	SSI3_CLK_SLDCDC2 _CLK_PC31	SSI3_RXDAT_SLDCDC2 _RS_PC29	SSI3_TXDAT_SLDCDC2_ CS_PC30	KP_ROW1		11
10	SSI3_FS_SLDCDC2 _D0_PC28	SSI2_RXDAT_GPT5 _TIN_PC25	SSI2_FS_GPT5_TOUT _PC24	SSI2_CLK_GPT4_ TIN_PC27		10
9	SSI1_CLK_ PC23	SSI1_TXDAT _PC22	SSI1_FS_PC20	SSI1_RXDAT _PC21		9
8	SSI4_CLK_ PC19	SSI4_RXDAT _PC17	TIN_PC15	SSI4_FS_PC16		8
7	TOUT_PC14	CSI_HSYNC_UART5 _RTS_PB21	CSI_D7_UART5_ RXD_PB19	CSI_D6_UART5 _TXD_PB18		7
6	CSI_D5_PB17	CSI_PIXCLK _PB16	CSI_D4_PB14	CSI_D3_UART6 _RTS_PB13		6
5	CSI_MCLK _PB15	CSI_D2_UART6_ CTS_PB12	CSI_D0_UART6_ TXD_PB10	SD2_CLK_MSHC _SCLK_PB9		5
4	CSI_D1_UART6 _RXD_PB11	SD2_CMD_MSHC _BS_PB8	SD2_D2_MSHC_ DATA2_PB6	VSYNC_PA29	CLS_PA25	4
3	SD2_D3_MSHC _DATA3_PB7	SD2_D1_MSHC_ DATA1_PB5	OE_ACD_ PA31	SPL_SPR_PA27	LD17_PA23	3
2	GND	GND	CONTRAST _PA30	PS_PA26	LD16_PA22	2
1	GND	GND	SD2_D0_MSHC_ DATA0_PB4	HSYNC_PA28	LD15_PA21	1
	A	B	C	D	E	

i.MX27 and i.MX27L Data Sheet, Rev. 2, 3/2019

Table 61. i.MX27 (19 mm × 19 mm) MAPBGA Pin Assignments (continued)

18	GND	USBH1_SUSP_PB22	NVDD14	NVDD7	NVDD7	NVDD13	18
17	QVDD	QVDD	QVDD	NVDD14	UPLLVDD	UPLLVSS	17
16	TRST_B	NVDD8	QVDD	QVDD	QVDD	QVDD	16
15	TCK	NVDD8	QVDD	GND	GND	GND	15
14	UART3_RXD_PE9	NVDD9	QVDD	GND	GND	GND	14
13	KP_COL1	NVDD9	QVDD	GND	GND	GND	13
12	I2C_DATA_PD17	NVDD10	QVDD	GND	GND	GND	12
11	KP_ROW0	NVDD10	QVDD	GND	GND	GND	11
10	SSI2_TXDAT_GPT4_TOUT_PC26	NVDD11	QVDD	GND	GND	GND	10
9	SSI4_TXDAT_PC18	NVDD11	QVDD	GND	GND	GND	9
8	CSI_VSYNC_UART5_CTS_PB20	NVDD11	QVDD	QVDD	QVDD	QVDD	8
7	GND	GND	QVDD	NVDD12	NVDD1	NVDD1	7
6	GND	NVDD15	NVDD15	NVDD12	NVDD1	NVDD1	6
5							5
4	REV_PA24	LD11_PA17	LD9_PA15	LD4_PA10	LSCLK_PA5	NFCLE_ETMTRACEPKT0_PPF1	4
3	LD14_PA20	LD10_PA16	LD6_PA12	LD2_PA8	NFCE_B_ETMTRACEPKT2_PPF3	NFRE_B_ETMPIPESTAT1_PPF5	3
2	LD12_PA18	LD7_PA13	LD5_PA11	LD1_PA7	NFRB_ETMTRACEPKT3_PPF0	NFALE_ETMPIPESTAT0_PPF4	2
1	LD13_PA19	LD8_PA14	LD3_PA9	LD0_PA6	NFWP_B_ETMTRACEPKT1_PPF2	NFWE_B_ETMPIPESTAT2_PPF6	1
	F	G	H	J	K	L	

Table 61. i.MX27 (19 mm × 19 mm) MAPBGA Pin Assignments (continued)

18	RTCVD	FPMVD	NVDD6	FUSEVD	BOOT2	18
17	RTCVSS	FPMVSS	NVDD6	FUSEVSS	MPLLSS	17
16	QVDD	QVDD	QVDD	QVDD	QVDD	16
15	GND	GND	GND	GND	QVDD	15
14	GND	GND	GND	GND	QVDD	14
13	GND	GND	GND	GND	QVDD	13
12	GND	GND	GND	GND	QVDD	12
11	GND	GND	GND	GND	QVDD	11
10	GND	GND	GND	GND	QVDD	10
9	GND	GND	GND	GND	QVDD	9
8	QVDD	QVDD	QVDD	QVDD	QVDD	8
7	QVDD	D0	NVDD2	NVDD2	NVDD2	7
6	D11	D7	MA10	NVDD2	A1	6
5						5
4	D13	D8	NC_P4_1	A12	A7	4
3	D12	D5	D3	A13	A8	3
2	D14	D9	D4	D1	A9	2
1	D15	D10	D6	D2	A11	1
	M	N	P	R	T	

Table 61. i.MX27 (19 mm × 19 mm) MAPBGA Pin Assignments (continued)

18	AVSS	GND		PC_VS1_ATA_ DA1_PF14	PC_WAIT_B _ATA_CS1_PF18	18
17	AVDD	MPLLVD		PC_CD2_B_ATA_ DIOW_PF19	EXT_60M	17
16	NVDD4	NVDD5		OE_B	EB0_B	16
15	NVDD4	NVDD5		CS0_B	CS1_B	15
14	NVDD4	CS5_B_ETM TRACECLK_PF22		CS4_B_ETMTRACE SYNC_PF21	RW_B	14
13	SDCKE1	SDCKE0		SDCLK_B	SDCLK	13
12	NVDD3	DQM1		RAS_B	DQM0	12
11	NVDD3	SD2		DQM3	SD0	11
10	QVDD	SD6		SDQS0	A15	10
9	NVDD2	SD12		SD9	SD7	9
8	NVDD2	GND		SD13	SD11	8
7	NVDD2	GND		A19	SD15	7
6	SD29	A22		SD17	SD16	6
5				SD20	A20	5
4	A3	SD31	SD27	SD26	SD22	4
3	A4	SDBA0	SDQS3	SD28	SD24	3
2	A5	A0	A25	A24	A23	2
1	A6	A2	SDBA1	SD30	SD25	1
	U	V	W	Y	AA	

Table 61. i.MX27 (19 mm × 19 mm) MAPBGA Pin Assignments (continued)

	18	PC_CD1_B_ATA _DIOR_P20	EXT_266M	18
	17	JTAG_CTRL	CLKO_PF15	17
	16	EB1_B	BCLK	16
	15	ECB_B	LBA_B	15
	14	CS2_B	CS3_B	14
	13	SDWE_B	CAS_B	13
	12	A10	DQM2	12
	11	SD1	SD3	11
	10	SD4	A14	10
	9	SD5	A16	9
	8	SD10	SD8	8
	7	SD14	A17	7
	6	SDQS1	A18	6
	5	SD19	SD18	5
	4	SD21	A21	4
	3	SDQS2	SD23	3
	2	GND	GND	2
	1	GND	GND	1
		AB	AC	

Table 62 shows the device pin list, sorted by signal identification, including pad locations for ground and power supply voltages.

Table 62. i.MX27 (19 mm × 19 mm) MAPBGA Contact Name Listing

Contact Name	Location
A0	V2
A1	T6
A10	AB12
A11	T1
A12	R4
A13	R3
A14	AC10
A15	AA10
A16	AC9
A17	AC7
A18	AC6
A19	Y7
A2	V1
A20	AA5
A21	AC4
A22	V6
A23	AA2
A24	Y2
A25	W2
A3	U4
A4	U3
A5	U2
A6	U1
A7	T4
A8	T3
A9	T2
ATA_DATA0_SD3_D0_PD2	P20
ATA_DATA1_SD3_D1_PD3	P21
ATA_DATA10_ETMTRACEPKT9_PD12	U23
ATA_DATA11_ETMTRACEPKT8_PD13	U22
ATA_DATA12_ETMTRACEPKT7_PD14	U21

Table 62. i.MX27 (19 mm × 19 mm) MAPBGA Contact Name Listing (continued)

Contact Name	Location
ATA_DATA13_ETMTRACEPKT6_PD15	U20
ATA_DATA14_ETMTRACEPKT5_PD16	V23
ATA_DATA15_ETMTRACEPKT4_PF23	V22
ATA_DATA2_SD3_D2_PD4	R23
ATA_DATA3_SD3_D3_PD5	R22
ATA_DATA4_ETMTRACEPKT14_PD6	R21
ATA_DATA5_ETMTRACEPKT13_PD7	R20
ATA_DATA6_FEC_MDIO_PD8	T23
ATA_DATA7_ETMTRACEPKT12_PD9	T22
ATA_DATA8_ETMTRACEPKT11_PD10	T20
ATA_DATA9_ETMTRACEPKT10_PD11	T21
AVDD	U17
AVSS	U18
BCLK	AC16
BOOT0	V21
BOOT1	V20
BOOT2	T18
BOOT3	W23
CAS_B	AC13
CLKMODE0	AA22
CLKMODE1	Y22
CLKO_PF15	AC17
CLS_PA25	E4
CONTRAST_PA30	C2
CS0_B	Y15
CS1_B	AA15
CS2_B	AB14
CS3_B	AC14
CS4_B_ETMTRACESYNC_PF21	Y14
CS5_B_ETMTRACECLK_PF22	V14
CSI_D0_UART6_TXD_PB10	C5
CSI_D1_UART6_RXD_PB11	A4
CSI_D2_UART6_CTS_PB12	B5

Table 62. i.MX27 (19 mm × 19 mm) MAPBGA Contact Name Listing (continued)

Contact Name	Location
CSI_D3_UART6_RTS_PB13	D6
CSI_D4_PB14	C6
CSI_D5_PB17	A6
CSI_D6_UART5_TXD_PB18	D7
CSI_D7_UART5_RXD_PB19	C7
CSI_HSYNC_UART5_RTS_PB21	B7
CSI_MCLK_PB15	A5
CSI_PIXCLK_PB16	B6
CSI_VSYNC_UART5_CTS_PB20	F8
CSPI1_MISO_PD30	A21
CSPI1_MOSI_PD31	C20
CSPI1_RDY_PD25	B20
CSPI1_SCLK_PD29	D19
CSPI1_SS0_PD28	B21
CSPI1_SS1_PD27	C21
CSPI1_SS2_USBH2_DATA5_PD26	D20
CSPI2_MISO_USBH2_DATA2_PD23	E20
CSPI2_MOSI_USBH2_DATA1_PD24	D23
CSPI2_SCLK_USBH2_DATA0_PD22	D22
CSPI2_SS0_USBH2_DATA6_PD21	C23
CSPI2_SS1_USBH2_DATA3_PD20	C22
CSPI2_SS2_USBH2_DATA4_PD19	D21
D0	N7
D1	R2
D10	N1
D11	M6
D12	M3
D13	M4
D14	M2
D15	M1
D2	R1
D3	P3
D4	P2

Table 62. i.MX27 (19 mm × 19 mm) MAPBGA Contact Name Listing (continued)

Contact Name	Location
D5	N3
D6	P1
D7	N6
D8	N4
D9	N2
DQM0	AA12
DQM1	V12
DQM2	AC12
DQM3	Y11
EB0_B	AA16
EB1_B	AB16
ECB_B	AB15
EXT_266M	AC18
EXT_60M	AA17
EXTAL26M	Y23
EXTAL32K	N23
FPMVDD	N18
FPMVSS	N17
FUSEVDD	R18
FUSEVSS	R17
GND	A1
GND	A2
GND	A22
GND	A23
GND	AB1
GND	AB2
GND	AB22
GND	AB23
GND	AC1
GND	AC2
GND	AC22
GND	AC23
GND	B1

Table 62. i.MX27 (19 mm × 19 mm) MAPBGA Contact Name Listing (continued)

Contact Name	Location
GND	B2
GND	B22
GND	B23
GND	F6
GND	F7
GND	F18
GND	G7
GND	J9
GND	J10
GND	J11
GND	J12
GND	J13
GND	J14
GND	J15
GND	K9
GND	K10
GND	K11
GND	K12
GND	K13
GND	K14
GND	K15
GND	L9
GND	L10
GND	L11
GND	L12
GND	L13
GND	L14
GND	L15
GND	M9
GND	M10
GND	M11
GND	M12
GND	M13

Table 62. i.MX27 (19 mm × 19 mm) MAPBGA Contact Name Listing (continued)

Contact Name	Location
GND	M14
GND	M15
GND	N9
GND	N10
GND	N11
GND	N12
GND	N13
GND	N14
GND	N15
GND	P9
GND	P10
GND	P11
GND	P12
GND	P13
GND	P14
GND	P15
GND	R9
GND	R10
GND	R11
GND	R12
GND	R13
GND	R14
GND	R15
GND	V7
GND	V8
GND	V18
HSYNC_PA28	D1
I2C_CLK_PD18	B13
I2C_DATA_PD17	F12
I2C2_SCL_PC6	G23
I2C2_SDA_PC5	G22
IOIS16_ATA_INTRQ_PF9	AA20
JTAG_CTRL	AB17

Table 62. i.MX27 (19 mm × 19 mm) MAPBGA Contact Name Listing (continued)

Contact Name	Location
KP_COL0	D13
KP_COL1	F13
KP_COL2	B14
KP_COL3	C14
KP_COL4	A15
KP_COL5	B15
KP_ROW0	F11
KP_ROW1	D11
KP_ROW2	B12
KP_ROW3	A12
KP_ROW4	C12
KP_ROW5	D12
LBA_B	AC15
LD0_PA6	J1
LD1_PA7	J2
LD10_PA16	G3
LD11_PA17	G4
LD12_PA18	F2
LD13_PA19	F1
LD14_PA20	F3
LD15_PA21	E1
LD16_PA22	E2
LD17_PA23	E3
LD2_PA8	J3
LD3_PA9	H1
LD4_PA10	J4
LD5_PA11	H2
LD6_PA12	H3
LD7_PA13	G2
LD8_PA14	G1
LD9_PA15	H4
LSCLK_PA5	K4
MA10	P6

Table 62. i.MX27 (19 mm × 19 mm) MAPBGA Contact Name Listing (continued)

Contact Name	Location
MPLLVD	V17
MPLLVS	T17
NC_P4_1	P4
NFALE_ETMPIPESTAT0_P4	L2
NFCE_B_ETMTRACEPKT2_P3	K3
NFCLE_ETMTRACEPKT0_P1	L4
NFRB_ETMTRACEPKT3_P0	K2
NFRE_B_ETMPIPESTAT1_P5	L3
NFWE_B_ETMPIPESTAT2_P6	L1
NFWP_B_ETMTRACEPKT1_P2	K1
NVDD1	K6
NVDD1	K7
NVDD1	L6
NVDD1	L7
NVDD10	G11
NVDD10	G12
NVDD11	G8
NVDD11	G9
NVDD11	G10
NVDD12	J6
NVDD12	J7
NVDD13	L18
NVDD14	H18
NVDD14	J17
NVDD15	G6
NVDD15	H6
NVDD2	P7
NVDD2	R6
NVDD2	R7
NVDD2	T7
NVDD2	U7
NVDD2	U8
NVDD2	U9

Table 62. i.MX27 (19 mm × 19 mm) MAPBGA Contact Name Listing (continued)

Contact Name	Location
NVDD3	U11
NVDD3	U12
NVDD4	U14
NVDD4	U15
NVDD4	U16
NVDD5	V15
NVDD5	V16
NVDD6	P17
NVDD6	P18
NVDD7	J18
NVDD7	K18
NVDD8	G15
NVDD8	G16
NVDD9	G13
NVDD9	G14
OE_ACD_PA31	C3
OE_B	Y16
OSC26M_TEST	W20
OSC26VDD	W22
OSC26VSS	W21
OSC32K_BYPASS	M21
OSC32VDD	N21
OSC32VSS	N22
PC_BVD1_ATA_DMARQ_PF12	AA19
PC_BVD2_ATA_DMACK_PF11	AB20
PC_CD1_B_ATA_DIOR_PF20	AB18
PC_CD2_B_ATA_DIOW_PF19	Y17
PC_POE_ATA_BUFFER_EN_PF7	Y20
PC_PWRON_ATA_DA2_PF16	AC19
PC_READY_ATA_CS0_PF17	AB19
PC_RST_ATA_RESET_B_PF10	Y19
PC_RW_B_ATA_IORDY_PF8	AB21
PC_VS1_ATA_DA1_PF14	Y18

Table 62. i.MX27 (19 mm × 19 mm) MAPBGA Contact Name Listing (continued)

Contact Name	Location
PC_VS2_ATA_DA0_PF13	AC20
PC_WAIT_B_ATA_CS1_PF18	AA18
POR_B	Y21
POWER_CUT	M23
POWER_ON_RESET	M22
PS_PA26	D2
PWMO_PE5	A14
QVDD	F17
QVDD	G17
QVDD	H7
QVDD	H8
QVDD	H9
QVDD	H10
QVDD	H11
QVDD	H12
QVDD	H13
QVDD	H14
QVDD	H15
QVDD	H16
QVDD	H17
QVDD	J8
QVDD	J16
QVDD	K8
QVDD	K16
QVDD	L8
QVDD	L16
QVDD	M7
QVDD	M8
QVDD	M16
QVDD	N8
QVDD	N16
QVDD	P8
QVDD	P16

Table 62. i.MX27 (19 mm × 19 mm) MAPBGA Contact Name Listing (continued)

Contact Name	Location
QVDD	R8
QVDD	R16
QVDD	T8
QVDD	T9
QVDD	T10
QVDD	T11
QVDD	T12
QVDD	T13
QVDD	T14
QVDD	T15
QVDD	T16
QVDD	U10
RAS_B	Y12
RESET_IN_B	AA21
RESET_OUT_B_PE17	AC21
REV_PA24	F4
RTCK_OWIRE_PE16	A18
RTCVDD	M18
RTCVSS	M17
RW_B	AA14
SD0	AA11
SD1	AB11
SD1_CLK_CSPI3_SCLK_PE23	C19
SD1_CMD_CSPI3_MOSI_PE22	A20
SD1_D0_CSPI3_MISO_PE18	B18
SD1_D1_PE19	A19
SD1_D2_PE20	B19
SD1_D3_CSPI3_SS_PE21	D18
SD10	AB8
SD11	AA8
SD12	V9
SD13	Y8
SD14	AB7

Table 62. i.MX27 (19 mm × 19 mm) MAPBGA Contact Name Listing (continued)

Contact Name	Location
SD15	AA7
SD16	AA6
SD17	Y6
SD18	AC5
SD19	AB5
SD2	V11
SD2_CLK_MSHC_SCLK_PB9	D5
SD2_CMD_MSHC_BS_PB8	B4
SD2_D0_MSHC_DATA0_PB4	C1
SD2_D1_MSHC_DATA1_PB5	B3
SD2_D2_MSHC_DATA2_PB6	C4
SD2_D3_MSHC_DATA3_PB7	A3
SD20	Y5
SD21	AB4
SD22	AA4
SD23	AC3
SD24	AA3
SD25	AA1
SD26	Y4
SD27	W4
SD28	Y3
SD29	U6
SD3	AC11
SD3_CLK_ETMTRACEPKT15_PD1	P22
SD3_CMD_PD0	N20
SD30	Y1
SD31	V4
SD4	AB10
SD5	AB9
SD6	V10
SD7	AA9
SD8	AC8
SD9	Y9

Table 62. i.MX27 (19 mm × 19 mm) MAPBGA Contact Name Listing (continued)

Contact Name	Location
SDBA0	V3
SDBA1	W1
SDCKE0	V13
SDCKE1	U13
SDCLK	AA13
SDCLK_B	Y13
SDQS0	Y10
SDQS1	AB6
SDQS2	AB3
SDQS3	W3
SDWE_B	AB13
SPL_SPR_PA27	D3
SSI1_CLK_PC23	A9
SSI1_FS_PC20	C9
SSI1_RXDAT_PC21	D9
SSI1_TXDAT_PC22	B9
SSI2_CLK_GPT4_TIN_PC27	D10
SSI2_FS_GPT5_TOUT_PC24	C10
SSI2_RXDAT_GPT5_TIN_PC25	B10
SSI2_TXDAT_GPT4_TOUT_PC26	F10
SSI3_CLK_SLCDC2_CLK_PC31	A11
SSI3_FS_SLCDC2_D0_PC28	A10
SSI3_RXDAT_SLCDC2_RS_PC29	B11
SSI3_TXDAT_SLCDC2_CS_PC30	C11
SSI4_CLK_PC19	A8
SSI4_FS_PC16	D8
SSI4_RXDAT_PC17	B8
SSI4_TXDAT_PC18	F9
TCK	F15
TDI	D17
TDO	D16
TIN_PC15	C8
TMS	C18

Table 62. i.MX27 (19 mm × 19 mm) MAPBGA Contact Name Listing (continued)

Contact Name	Location
TOUT_PC14	A7
TRST_B	F16
UART1_CTS_PE14	B17
UART1_RTS_PE15	C17
UART1_RXD_PE13	A17
UART1_TXD_PE12	D15
UART2_CTS_KP_COL7_PE3	A13
UART2_RTS_KP_ROW7_PE4	C13
UART2_RXD_KP_ROW6_PE7	C15
UART2_TXD_KP_COL6_PE6	D14
UART3_CTS_PE10	B16
UART3_RTS_PE11	C16
UART3_RXD_PE9	F14
UART3_TXD_PE8	A16
UPLLVDD	K17
UPLLVSS	L17
USB_OC_B_PB24	E22
USB_PWR_PB23	E21
USBH1_FS_UART4_RTS_PB26	F20
USBH1_OE_B_PB27	F21
USBH1_RCV_PB25	E23
USBH1_RXDM_PB30	G20
USBH1_RXDP_UART4_RXD_PB31	G21
USBH1_SUSP_PB22	G18
USBH1_TXDM_UART4_TXD_PB28	F22
USBH1_TXDP_UART4_CTS_PB29	F23
USBH2_CLK_PA0	J23
USBH2_DATA7_PA2	K21
USBH2_DIR_PA1	K20
USBH2_NXT_PA3	K22
USBH2_STP_PA4	K23
USBOTG_CLK_PE24	L22
USBOTG_DATA0_PC9	H22

Table 62. i.MX27 (19 mm × 19 mm) MAPBGA Contact Name Listing (continued)

Contact Name	Location
USBOTG_DATA1_PC11	J20
USBOTG_DATA2_PC10	H23
USBOTG_DATA3_PC13	J22
USBOTG_DATA4_PC12	J21
USBOTG_DATA5_PC7	H20
USBOTG_DATA6_PC8	H21
USBOTG_DATA7_PE25	L20
USBOTG_DIR_KP_ROW7A_PE2	M20
USBOTG_NXT_KP_COL6A_PE0	L21
USBOTG_STP_KP_ROW6A_PE1	L23
VSYNC_PA29	D4
XTAL26M	AA23
XTAL32K	P23

6 Revision History

Table 63 summarizes revisions to this document since the previous release.

Table 63. Document Revision History

Rev. No.	Date	Significant Change(s)
2	3/2019	<ul style="list-style-type: none"> Updated Figure 72 through Figure 76. In Section 5, "Package Information and Pinout" standardized section, table and figure titles.
1.8	12/2012	<ul style="list-style-type: none"> In Table 3, "i.MX27/MX27L Signal Descriptions," updated Function/Notes column for SD3_CMD and SD3_CLK. In Table 11, "Current Consumption," for parameter 4, Power Gate, updated maximum power to 216 μA.
1.7	05/2011	In Table 8, "DPLL FREQUENCY Specifications," added the MPLL row along with a footnote.
1.6	08/2010	<ul style="list-style-type: none"> Added a new section- Section 4.3.13.1, "WEIM Synchronous Mode Sample Point." Updated ID WE15 in Table 50.
1.5	12/2009	Updated Table 1, "Ordering Information," to include new part numbers and table footnote.
1.4	5/2009	<ul style="list-style-type: none"> In Table 11, "Current Consumption," a column for Max value was added. In Table 59, "i.MX27 (17 mm \times 17 mm) MAPBGA Pin Assignments," inaccurate pin list information was corrected and the table reformatted. In Table 60, "i.MX27 (17 mm \times 17 mm) MAPBGA Contact Name Listing," inaccurate pin list information was corrected and the table was reformatted. Reformatted Table 62, "i.MX27 (19 mm \times 19 mm) MAPBGA Contact Name Listing."
1.3	11/2008	<ul style="list-style-type: none"> In Table 3, "i.MX27/MX27L Signal Descriptions," switched FEC_TXD0 and FEC_TXD1 for SD3_CMD and SD3_CLK. In Table 23, "CSPI Interface Timing Parameters," updated t6' and t13, and removed t14. In Table 60, "i.MX27 (17 mm \times 17 mm) MAPBGA Contact Name Listing," changed "RW" to "RW_B." Added Table 59, "i.MX27 (17 mm \times 17 mm) MAPBGA Pin Assignments." Updated Table 62, "i.MX27 (19 mm \times 19 mm) MAPBGA Contact Name Listing."
1.2	7/2008	Corrected part number in Section 1.3, "Ordering Information," on p. 4. Part number previously listed as MCIMX27FVOP4A has been corrected to read MCIMX27VOP4A.
1.1	7/2008	Formatting and template work.

How to Reach Us:

Home Page:

nxp.com

Web Support:

nxp.com/support

Information in this document is provided solely to enable system and software implementers to use NXP products. There are no express or implied copyright licenses granted hereunder to design or fabricate any integrated circuits based on the information in this document. NXP reserves the right to make changes without further notice to any products herein.

NXP makes no warranty, representation, or guarantee regarding the suitability of its products for any particular purpose, nor does NXP assume any liability arising out of the application or use of any product or circuit, and specifically disclaims any and all liability, including without limitation consequential or incidental damages. "Typical" parameters that may be provided in NXP data sheets and/or specifications can and do vary in different applications, and actual performance may vary over time. All operating parameters, including "typicals," must be validated for each customer application by customer's technical experts. NXP does not convey any license under its patent rights nor the rights of others. NXP sells products pursuant to standard terms and conditions of sale, which can be found at the following address:

nxp.com/SalesTermsandConditions.

While NXP has implemented advanced security features, all products may be subject to unidentified vulnerabilities. Customers are responsible for the design and operation of their applications and products to reduce the effect of these vulnerabilities on customer's applications and products, and NXP accepts no liability for any vulnerability that is discovered. Customers should implement appropriate design and operating safeguards to minimize the risks associated with their applications and products.

NXP, the NXP logo, NXP SECURE CONNECTIONS FOR A SMARTER WORLD, COOLFLUX, EMBRACE, GREENCHIP, HITAG, I2C BUS, ICODE, JCOP, LIFE VIBES, MIFARE, MIFARE CLASSIC, MIFARE DESFire, MIFARE PLUS, MIFARE FLEX, MANTIS, MIFARE ULTRALIGHT, MIFARE4MOBILE, MIGLO, NTAG, ROADLINK, SMARTLX, SMARTMX, STARPLUG, TOPFET, TRENCHMOS, UCODE, Freescale, the Freescale logo, AltiVec, C³, CodeTEST, CodeWarrior, ColdFire, ColdFire+, C²Ware, the Energy Efficient Solutions logo, Kinetis, Layerscape, MagniV, mobileGT, PEG, PowerQUICC, Processor Expert, QoriQ, QoriQ Qonverge, Ready Play, SafeAssure, the SafeAssure logo, StarCore, Symphony, VortiQa, Vybrid, Airfast, BeeKit, BeeStack, CoreNet, Flexis, MXC, Platform in a Package, QUICC Engine, SMARTMOS, Tower, TurboLink, and UMEMS are trademarks of NXP B.V. All other product or service names are the property of their respective owners. Arm, AMBA, Artisan, Cortex, Jazelle, Keil, SecurCore, Thumb, TrustZone, and μ Vision are registered trademarks of Arm Limited (or its subsidiaries) in the EU and/or elsewhere. Arm7, Arm9, Arm11, big.LITTLE, CoreLink, CoreSight, DesignStart, Mali, Mbed, NEON, POP, Sensinode, Socrates, ULINK and Versatile are trademarks of Arm Limited (or its subsidiaries) in the EU and/or elsewhere. All rights reserved. Oracle and Java are registered trademarks of Oracle and/or its affiliates. The Power Architecture and Power.org word marks and the Power and Power.org logos and related marks are trademarks and service marks licensed by Power.org.

© 2008-2019 NXP B.V.

Document Number: MCIMX27EC

Rev. 2

3/2019



Looking for pricing, stock, or lifecycle information?

Click below to explore more details on WIN SOURCE:

- ⊖ [View MCIMX27LVOP4AR2 on WIN SOURCE](#)
- ⊖ [Freescale Semiconductor - NXP Information](#)

Optimize Your Supply Chain with WIN SOURCE Solutions

- ✓ Global Sourcing Solution
- ✓ Obsolete Management
- ✓ Cost Control Management
- ✓ Shortage Management
- ✓ Alternative Solution
- ✓ Excess Inventory Management