



**THE DATASHEET OF
MC9S12XDP512MAL**



DESCRIPTION

The MP6401 combines a low-dropout linear regulator with an integrated reset circuit. It operates from a 2.5V to 5.5V input voltage and regulates the output voltage with 2% accuracy at 1.8V, 2.5V, 3.3V or adjustable value. It delivers up to 300mA of load current. By combining an LDO linear regulator with a reset circuit, these products can reduce cost and save space in compact portable devices such as cell phones, smart phones, PDAs, PMPs, and portable GPS devices.

The MP6401 provides a push-pull, active-low that asserts when the regulator output voltage drops below the microprocessor supply threshold (-7.5% or -12.5% of nominal output voltage). Four reset delay time, 3.125ms, 25ms, 200ms and 1580ms can be selected. The MP6401 is available in 3mmx3mm TQFN8, 2mmx2mm TQFN6 and TSOT packages and is specified for operation from -40°C to 85°C.

FEATURES

- Low Quiescent Current of 80µA for Battery Powered Equipment
- Low 114mV Dropout at 300mA Output
- ±2% Accurate Output Voltage
- Fixed Output Voltage Options of 1.8V, 2.5V or 3.3V
- Adjustable Output Voltage from 1.229V to 5V Using an External Resistor Divider
- 15µV_{RMS} Ultra Low Noise Output
- PSRR: 57dB at 1kHz
- Input Reverse Current, Thermal and Short-Circuit Protection
- Microprocessor Reset with Four Delay time Options
- Push-Pull $\overline{\text{RESET}}$

APPLICATIONS

- Smart Phone and Cell Phone
- Portable GPS Devices
- Wireless Devices
- PDA and PMP

All MPS parts are lead-free and adhere to the RoHS directive. For MPS green status, please visit MPS website under Quality Assurance. "MPS" and "The Future of Analog IC Technology" are Registered Trademarks of Monolithic Power Systems, Inc.

TYPICAL APPLICATION

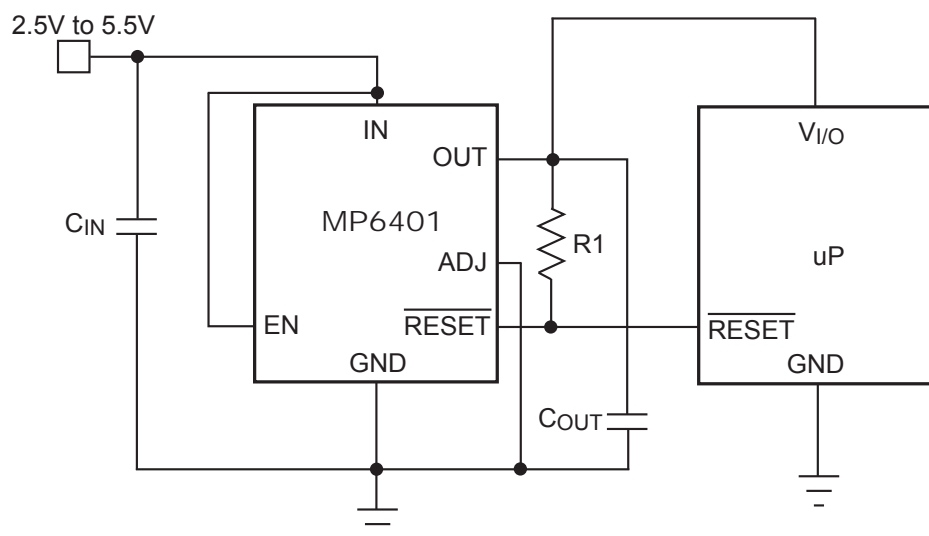

ORDERING INFORMATION

Part Number*	Package	Top Marking	Free Air Temperature (T _A)
MP6401DQT-18AD3	TQFN8 (3mmx3mm)	7T	-40°C to +85°C
MP6401DQT-18BD3		8T	
MP6401DQT-25AD3		5T	
MP6401DQT-25BD3		6T	
MP6401DQT-33BD3		4T	
MP6401DGT-18AD3		TQFN6 (2mmx2mm)	
MP6401DGT-18BD3	8T		
MP6401DGT-25AD3	5T		
MP6401DGT-25BD3	6T		
MP6401DGT-33BD3	4T		
MP6401DJ-18AD3	TSOT23-6		
MP6401DJ-18BD3		8T	
MP6401DJ-25AD3		5T	
MP6401DJ-25BD3		6T	
MP6401DJ-33BD3		4T	

* For other versions, contact factory for availability.

Note:

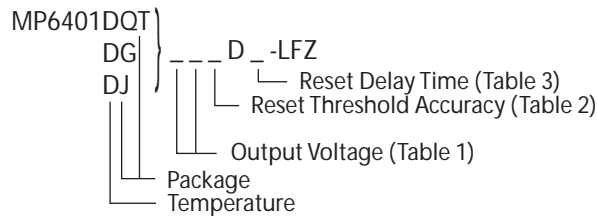

Table 1—Output Voltage Suffix Guide

Suffix	Output Voltage
18	1.8
25	2.5
33	3.3

Table 2—Reset Threshold Accuracy

Suffix	Vout Reset Threshold (%)
A	-7.5%
B	-12.5%

Table 3—Reset Delay Time Guide

Suffix	Typical Reset Delay Time (ms)
D1	3.125
D2	25
D3	200
D4	1580

PACKAGE REFERENCE

<p>TOP VIEW</p>	<p>TOP VIEW</p>	<p>TOP VIEW</p>
TQFN8 (3mm x 3mm)	TQFN6 (2mm x 2mm)	TSOT23-6

ABSOLUTE MAXIMUM RATINGS ⁽¹⁾

IN, EN, OUT	-0.3V to + 6 V
ADJ	-0.3V to 6V
RESET	-0.3V to 6V
Continuous Power Dissipation. (T _A = +25°C) ⁽²⁾	
TQFN8 (3mm x 3mm)	2.6W
TQFN6 (2mm x 2mm)	1.56W
TSOT	0.57W
Junction Temperature	150°C
Lead Temperature	260°C
Storage Temperature	-65°C to +150°C

Recommended Operating Conditions ⁽³⁾

Supply Voltage V _{IN}	2.5V to 5.5V
Operating Junct. Temp (T _J)	-40°C to +125°C

<i>Thermal Resistance</i> ⁽⁴⁾	θ_{JA}	θ_{JC}
TQFN8 (3mm x 3mm)	48	11 ... °C/W
TQFN6 (2mm x 2mm)	80	16 ... °C/W
TSOT	220	110 .. °C/W

Notes:

- Exceeding these ratings may damage the device.
- The maximum allowable power dissipation is a function of the maximum junction temperature T_J (MAX), the junction-to-ambient thermal resistance θ_{JA} , and the ambient temperature T_A. The maximum allowable continuous power dissipation at any ambient temperature is calculated by P_D (MAX) = (T_J (MAX)-T_A)/ θ_{JA} . Exceeding the maximum allowable power dissipation will cause excessive die temperature, and the regulator will go into thermal shutdown. Internal thermal shutdown circuitry protects the device from permanent damage. Thermal shutdown engages at T_J=150°C(TYP) and disengages at T_J=130°C(TYP)
- The device is not guaranteed to function outside of its operating conditions.
- Measured on JESD51-7 4-layer board.

ELECTRICAL CHARACTERISTICS

$V_{IN} = (V_{OUT} + 0.5V)$ or $+2.5V$, whichever is greater, $C_{OUT} = 3.3\mu F$. Typical Value at $T_A = +25^\circ C$ unless otherwise noted.

Parameter	Symbol	Condition	Min	Typ	Max	Unit
Input Supply Range	V_{IN}		2.5		5.5	V
Input Undervoltage Lockout	V_{UVLO}	V_{IN} falling	1.85	2.05	2.2	V
Hysteresis of UVLO	V_{HYS}			190		mV
Supply Current (Ground Current)	I_Q	$I_{OUT} = 0$		80	155	μA
Shutdown Supply Current	I_{SHDN}	$T_A = +25^\circ C$		0.1	1	μA
Regulation Circuit						
Output Current			300			mA
Output Voltage Accuracy (Fixed Output Voltage)		$1mA \leq I_{OUT} \leq 300mA$	-2		+2	%
Adjustable Output Voltage Range			V_{ADJ}		5	V
ADJ Reference Voltage	V_{ADJ}		1.205	1.229	1.253	V
ADJ Threshold				250		mV
ADJ Input Leakage Current	I_{ADJ}	$V_{ADJ} = 0, +1.2V$		± 20	± 100	nA
Dropout Voltage (Fixed Output Voltage) ⁽⁵⁾	ΔV_{DO}	$V_{OUT} = +3.3V, I_{OUT} = 300mA$		114	220	mV
Short Current Limit		$V_{IN} \geq 2.5V$		375		mA
In Regulation Current Limit		$V_{IN} \geq 2.5V$		500		mA
Input Reverse Leakage Current (OUT to IN Leakage Current)		$V_{IN} = 4V, V_{OUT} = 5V, EN$ deasserted, $T_A = +25^\circ C$		0.01	1	μA
EN Input Low Voltage	V_{IL}				$0.3V_{IN}$	V
EN Input High Voltage	V_{IH}		$0.7V_{IN}$			V
EN Input Current		$EN = V_{IN}$ or GND, $T_A = +25^\circ C$	-1	0.1	+1	μA
Thermal-Shutdown Temperature	T_{SHDN}			150		$^\circ C$
Thermal-Shutdown Hysteresis	ΔT_{SHDN}			20		$^\circ C$
Line Regulation		$V_{OUT} = 1.5V, 2.5V \leq V_{IN} \leq 5.5V, I_{OUT} = 10mA$		0.02		%/V
Load Regulation		$V_{OUT} = 1.5V, V_{IN} = 2.5V, 1mA \leq I_{OUT} \leq 150mA$		0.1		%
Output Voltage Noise		10Hz to 100kHz, $C_{IN} = 0.1\mu F, I_{OUT} = 100mA, V_{OUT} = 1.5V$		15		μV_{RMS}
Reset Circuit						
V_{OUT} Reset Threshold	V_{THOUT}	MP6401__ - __ AD_	90	92.5	95	% V_{OUT}
		MP6401__ - __ BD_	85	87.5	90	
V_{OUT} to Reset Delay				30		μs
Reset Delay Time	T_d	D1	2.2	3.125	4.0	ms
		D2	17.5	25	32.5	
		D3	140	200	260	
		D4	1106	1580	2054	

ELECTRICAL CHARACTERISTICS *(continued)*

$V_{IN} = (V_{OUT} + 0.5V)$ or +2.5V, whichever is greater, $C_{OUT} = 3.3\mu F$. Typical Value at $T_A = +25^\circ C$ unless otherwise noted.

Parameter	Symbol	Condition	Min	Typ	Max	Unit
RESET Output Voltage Push-Pull	V_{OL}	$V_{OUT} \geq 1.0V, I_{SINK} = 50\mu A,$ RESET asserted			0.3	V
		$V_{OUT} \geq 1.5V, I_{SINK} = 3.2mA,$ RESET asserted			0.4	
	V_{OH}	$V_{OUT} \geq 2.0V, I_{SOURCE} = 500\mu A,$ RESET deasserted	$0.8V_{OUT}$			

Notes:

5) Dropout Voltage is defined as the input to output differential when the output voltage drops 100mV below its nominal value.

PIN FUNCTIONS

TQFN8 Pin #	TQFN6 Pin#	TSOT Pin#	Name	Description
1	1	3	IN	Supply input pin.
2				
3	2	2	GND	Ground.
4	3	1	EN	Enable (Active High). Connect EN to IN generally. Don't float EN pin.
5	4	6	$\overline{\text{RESET}}$	Push-pull $\overline{\text{RESET}}$. It asserts when the OUT voltage drops below its threshold. When OUT voltage recover, $\overline{\text{RESET}}$ deasserts after a fix delay time (four options).
6	5	5	ADJ	Mode selector input. When ADJ is connected to the tap of an external resistor divider from the OUT to GND, the OUT voltage is adjustable. When ADJ is connected to GND, a preset output voltage is selected.
7	6	4	OUT	Regulator output pin.
8				

TYPICAL PERFORMANCE CHARACTERISTICS

$V_{IN}=5V$, $V_{OUT}=3.3V$, $C_{OUT}=3.3\mu F$, $T_A=-40^{\circ}C$ to $+85^{\circ}C$, Typical values are at $T_A=+25^{\circ}C$, unless otherwise noted.

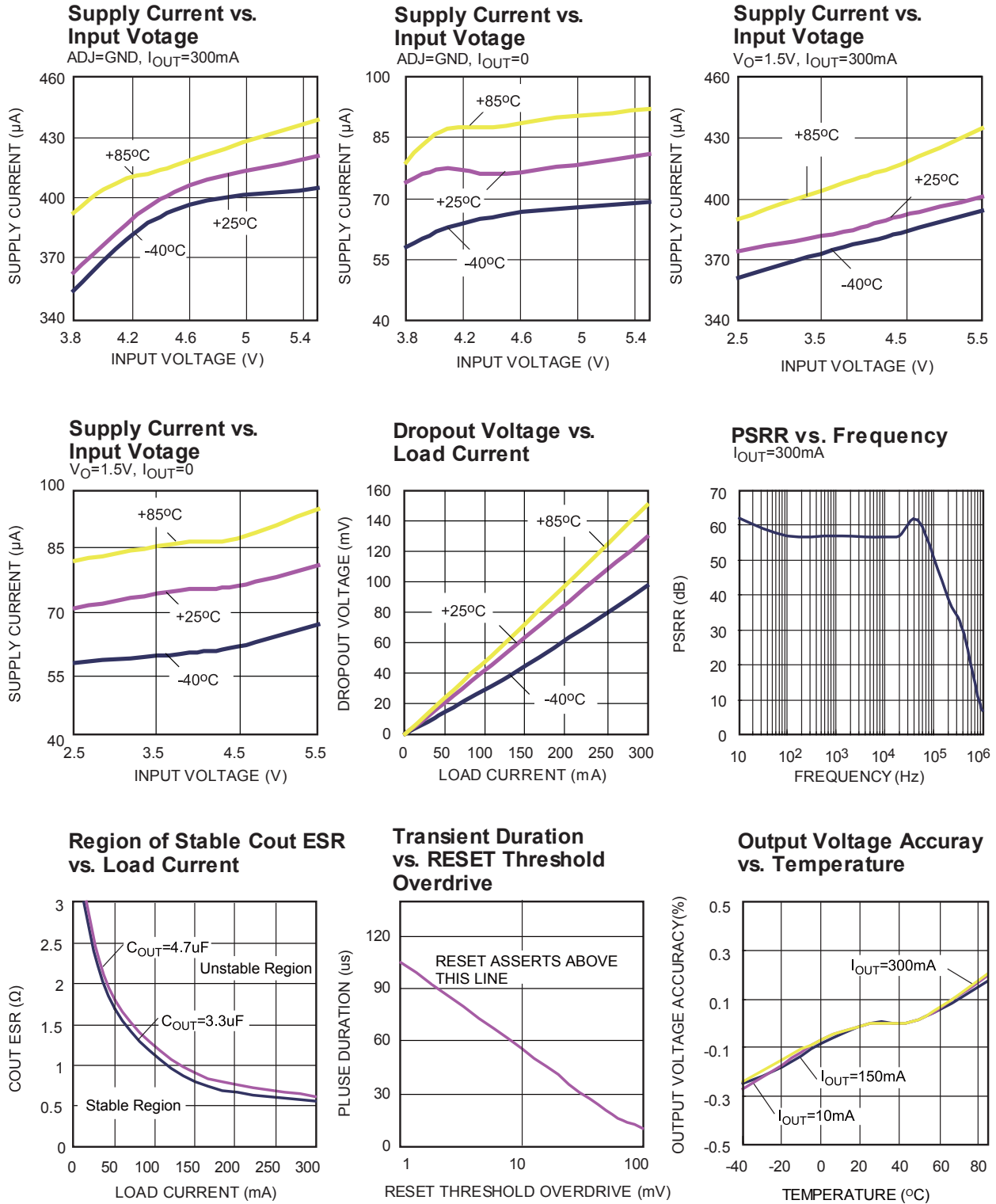

TYPICAL PERFORMANCE CHARACTERISTICS (continued)

$V_{IN}=5V$, $V_{OUT}=3.3V$, $C_{OUT}=3.3\mu F$, $T_A=-40^{\circ}C$ to $+85^{\circ}C$, Typical values are at $T_A=+25^{\circ}C$, unless otherwise noted.

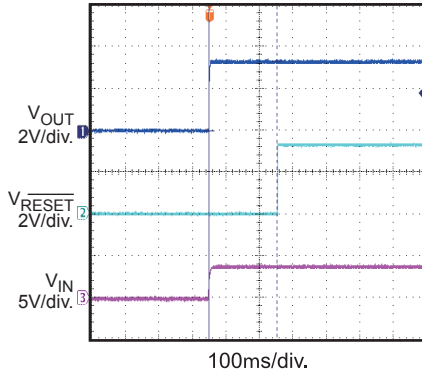
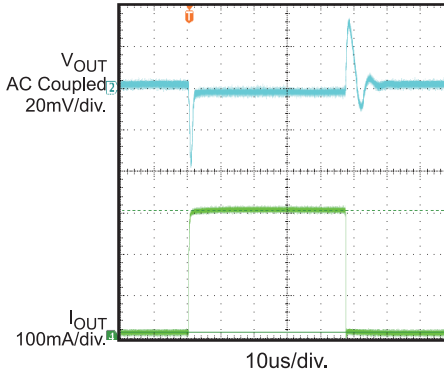
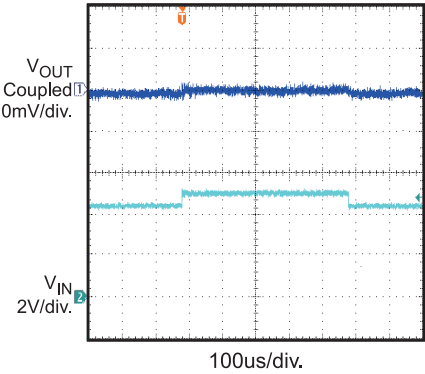
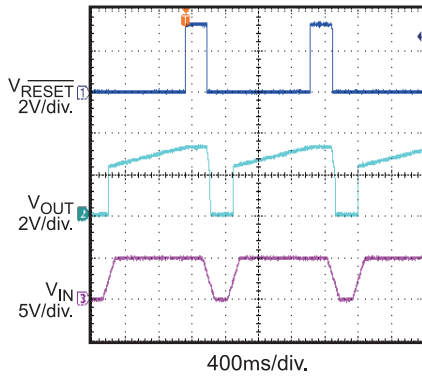
Start-up through V_{IN}
 $V_{IN} = 3.8V, I_{OUT} = 0$

Load-Transient Response
 $I_{OUT} = 10mA$ to $300mA$

Line-Transient Response
 $V_{IN} = 4.5V$ to $5V$, $I_{OUT} = 10mA$

Reset Response To V_{IN} Rising
 $ADJ=GND, I_{OUT} = 0$

BLOCK DIAGRAM

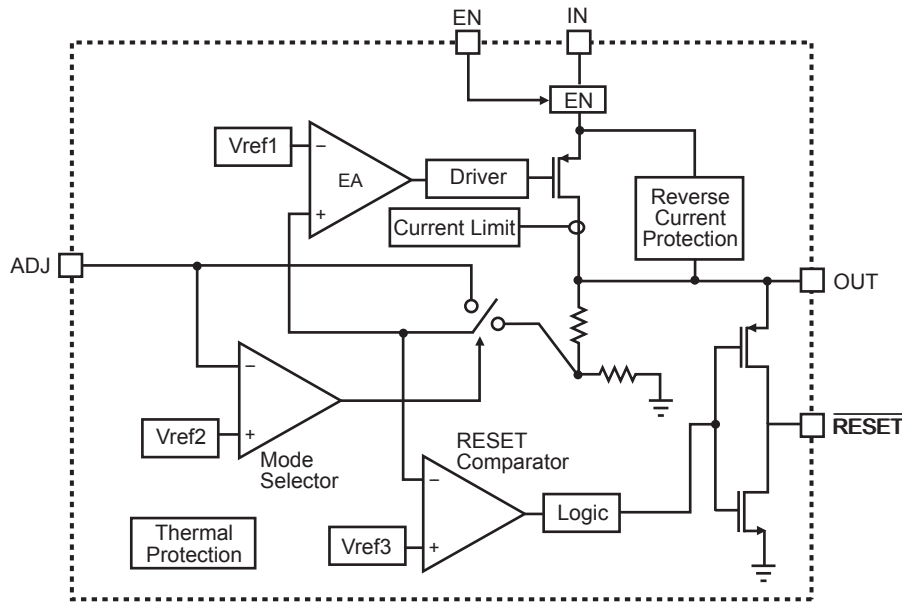

Figure 1—MP6401 Block Diagram

TIMING DIAGRAM

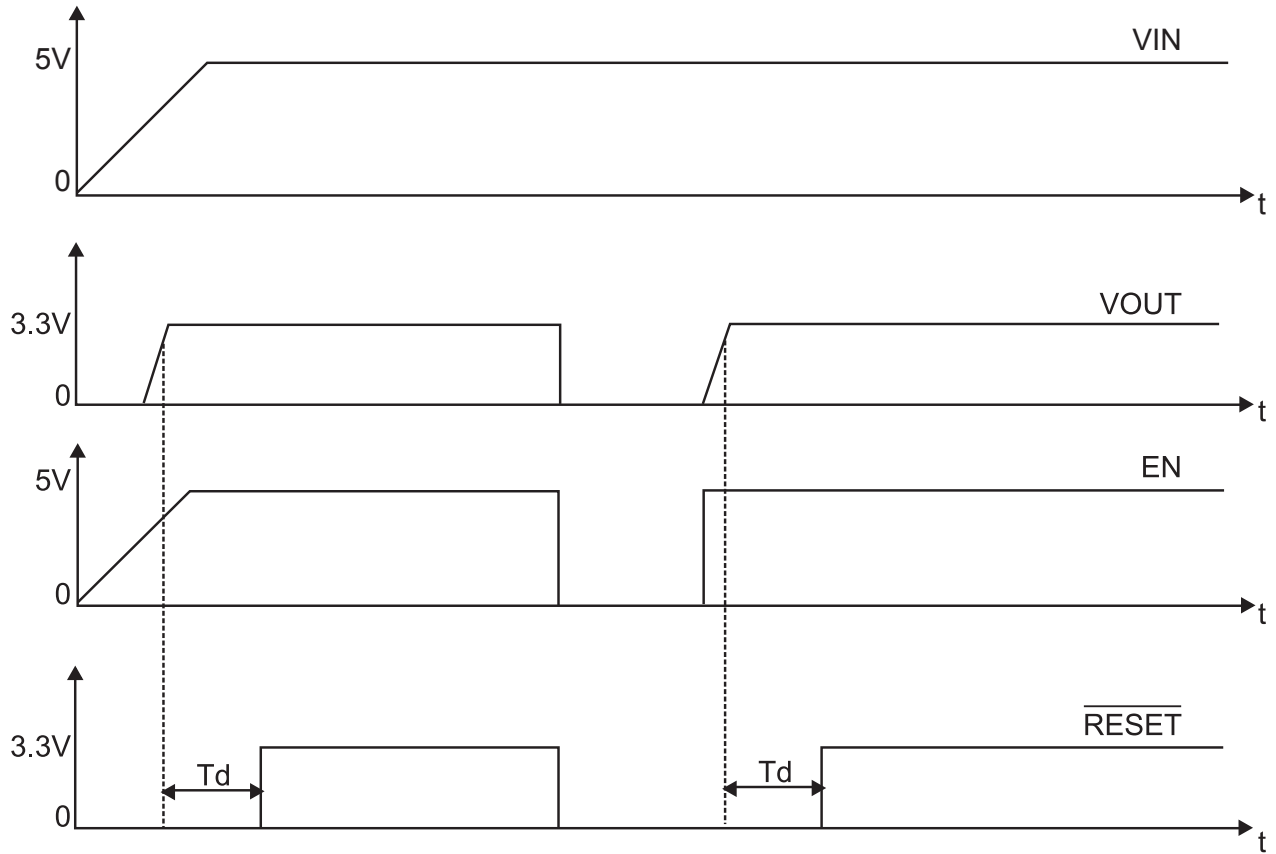

Figure 2—RESET Timing Diagram

OPERATION

The MP6401 integrates a low noise, low dropout, low quiescent current linear regulator and a microprocessor reset circuit. It operates from a 2.5V to 5.5V input voltage and regulates the fixed output voltage with 2% accuracy at 1.8V, 2.5V, 3.3V or adjustable value. The MP6401 can supply to 300mA of load current. The internal reset circuit is used to monitor the regulator output voltage. The $\overline{\text{RESET}}$ asserts when the regulator output voltage drops below the standard microprocessor supply threshold.

Linear Regulator

The MP6401 can output a fixed voltage (1.8V, 2.5V, 3.3V options) or adjustable voltage which ranges from 1.25V to 5V with 2.0% accuracy by operating from a +2.5V to +5.5V input. The MP6401 can supply up to 300mA of load current. When ADJ is connected to GND, a fixed output voltage is selected. Connecting ADJ pin to the tap of external resistor divider from the OUT to GND, adjustable output voltage is selected. The typical ADJ connection is shown in Fig 3.

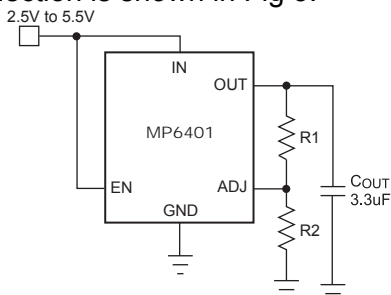

Figure 3—Output Voltage Adjusted with Resistor Divider

Reset Function

The reset circuit monitors the OUT voltage. $\overline{\text{RESET}}$ asserts while OUT voltage falls below its threshold. Two OUT voltage thresholds (-7.5% and -12.5%) are available. The power-up, power-down, and brownout conditions will make $\overline{\text{RESET}}$ asserted. So MP6401 monitor circuit could right control the microprocessor. $\overline{\text{RESET}}$ asserts when the input and output voltage below their thresholds. $\overline{\text{RESET}}$ asserts when EN is a low logic. When the assert trigger condition is removed, $\overline{\text{RESET}}$ will deassert after a fixed delay time. Four options of reset delay-time (see Table 3) can be selected.

EN Shutdown

The MP6401 can be switched ON or OFF by a logic input at the EN pin. A high voltage at this pin will turn the device on. When the EN pin is low, the regulator output is off and the supply current is reduced. Generally, the EN pin should be tied to IN to keep the regulator output always on. Do not float the EN pin.

Reverse Leakage Protection

An internal circuit monitors V_{IN} and V_{OUT} to control the reverse leakage current from OUT to IN. While V_{IN} decreases lower than V_{OUT} and EN still hold logic high, the monitor circuit turns off the pass element and its parasitic diode. Typically the reverse leakage current through pass element decreases to 0.1uA. $\overline{\text{RESET}}$ deasserts until V_{IN} returns greater than V_{OUT} and V_{OUT} is higher than its preset threshold.

MP6401 also can work with backup battery at OUT after input power supply is removed as shown in Fig 4. When input power supply is removed, $\overline{\text{RESET}}$ asserts. The backup battery will power the device through two external diodes and typically the current from OUT to ground is 40uA. So, the power supply removing does not erase RAM content if the voltage of backup battery is greater than memory's standby specification. The backup battery can be replaced by a super-cap, while the diode connected with battery is changed to a current-limiting resistor.

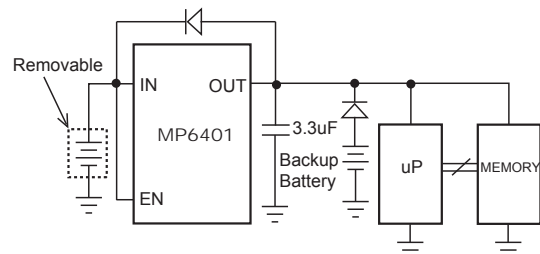

Figure 4— Maintain Memory with Backup Battery

Current Limit

The MP6401 includes a current limit structure which monitors and controls pass element gate voltage limiting the guaranteed maximum output current to 500mA.

Thermal Shutdown

Thermal protection turns off the pass element when the junction temperature exceeds +150°C, allowing to cool the IC. When the IC's junction temperature drops by 20°C, the pass element will be turned on again. Thermal protection limits total power dissipation on the MP6401. For reliable operation, junction temperature should be limited to 125 °C maximum.

APPLICATION INFORMATION

Adjustable Regulator Output

The OUT voltage of MP6401 has two modes available (fixed and adjustable output voltage). When ADJ pin is connected to GND, the regulator works in fixed voltage mode. The regulator output voltage will equal to preset voltage (1.8V, 2.5V or 3.3V options). In fixed voltage mode, the impedance between ADJ and ground should always be less than 50kΩ. Generally, ADJ is connected directly to ground.

When the ADJ pin is connected to the tap of an external resistor divider, the regulator works in adjustable voltage mode as shown in Fig 3. The output voltage is selected by resistor divider, thus

$$V_{OUT} = 1.229 \times \frac{R_1 + R_2}{R_2}$$

In adjustable voltage mode, R₂ equal to 13kΩ is recommended as a good tradeoff among stability, accuracy and high-frequency PSRR. R₂ should be not greater than 100kΩ.

Power Dissipation

The power dissipation for any package depends on the thermal resistance of the case and circuit board, the temperature difference between the junction and ambient air, and the rate of airflow. The power dissipation across the device can be represented by the equation:

$$P = (V_{IN} - V_{OUT}) \times I_{OUT}$$

The allowable power dissipation can be calculated using the following equation:

$$P_D (MAX) = (T_J (MAX) - T_A) / \theta_{JA}$$

Where (T_J(MAX)-T_A) is the temperature difference between the junction and the ambient environment, θ_{JA} is the thermal resistance from the junction to the ambient environment. Connecting the GND pin of MP6401 to ground using a large pad or ground plane helps to channel heat away.

Output Capacitor Selection

The MP6401 is designed specifically to work with very low ESR ceramic output capacitor 3.3uF (min). For performance consideration, a large ceramic capacitor such as 10uF is better. X7R or X5R capacitor dielectric is recommended.

OUT Voltage Transient Immunity

The MP6401 can be immune to OUT pin short negative transient. Typically, the immune duration is 60us with 10mV overdriving. A shorter negative transient can not make the \overline{RESET} output assert.

PACKAGE INFORMATION

TQFN8 (3mm x 3mm)

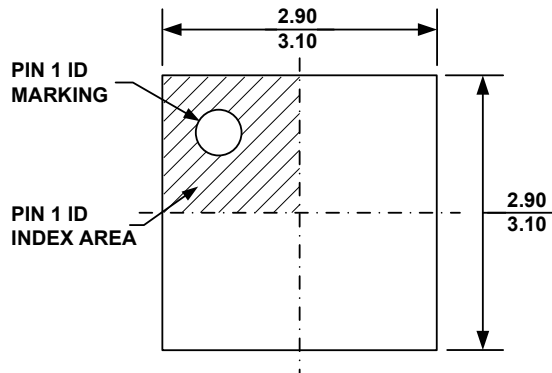

TOP VIEW

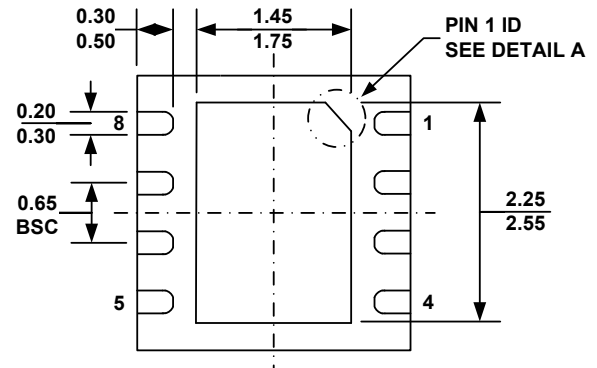

BOTTOM VIEW

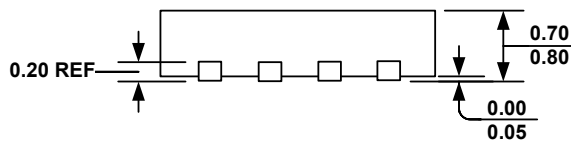

SIDE VIEW

PIN 1 ID OPTION A
0.30x45° TYP.

PIN 1 ID OPTION B
R0.20 TYP.

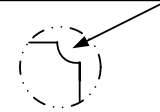

DETAIL A

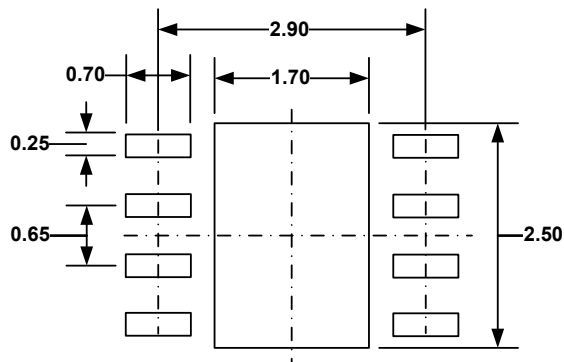

RECOMMENDED LAND PATTERN

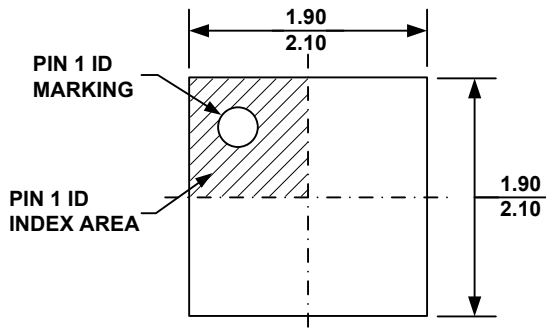
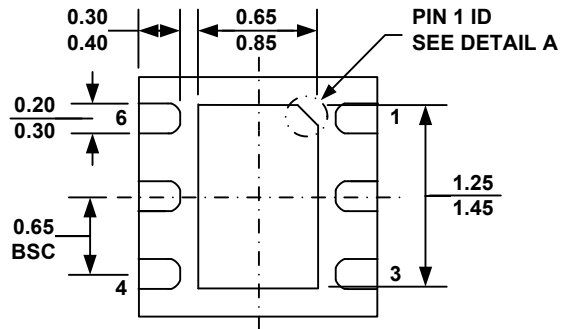
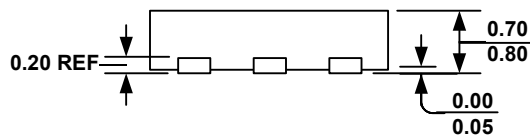
TQFN6 (2mm x 2mm)

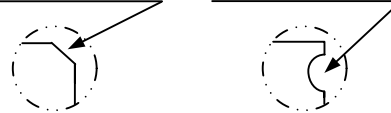
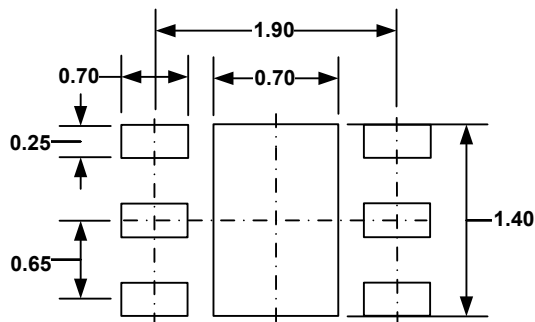
TOP VIEW

BOTTOM VIEW

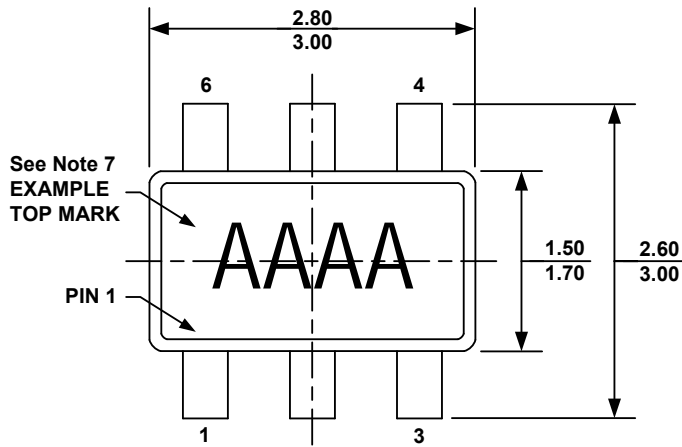
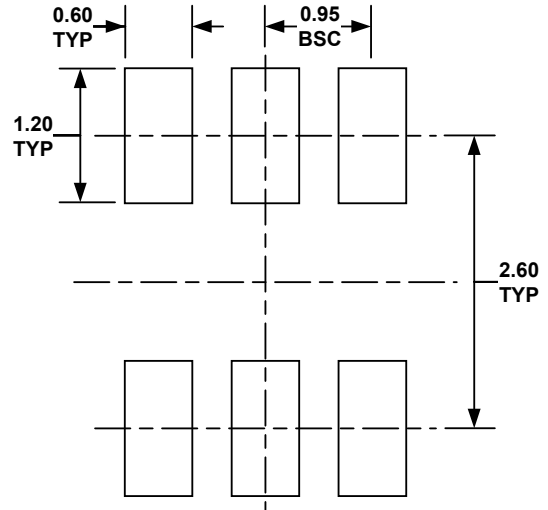
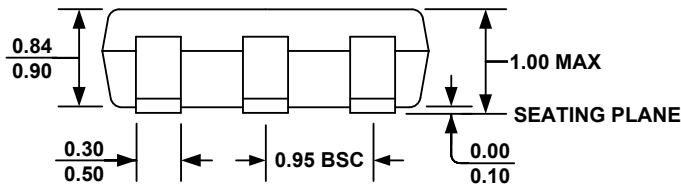
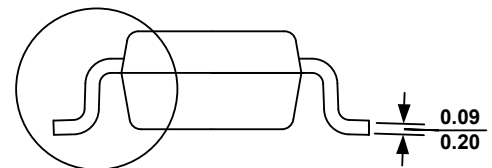
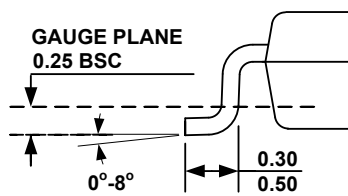
SIDE VIEW
PIN 1 ID OPTION A
 0.30x45° TYP.

PIN 1 ID OPTION B
 R0.20 TYP.

DETAIL A

RECOMMENDED LAND PATTERN
NOTE:

- 1) ALL DIMENSIONS ARE IN MILLIMETERS.
- 2) EXPOSED PADDLE SIZE DOES NOT INCLUDE MOLD FLASH.
- 3) LEAD COPLANARITY SHALL BE 0.10 MILLIMETER MAX.
- 4) JEDEC REFERENCE IS MO-229, VARIATION WCCC.
- 5) DRAWING IS NOT TO SCALE.

TSOT23-6

TOP VIEW

RECOMMENDED LAND PATTERN

FRONT VIEW

SEE DETAIL "A"
SIDE VIEW

DETAIL "A"
NOTE:

- 1) ALL DIMENSIONS ARE IN MILLIMETERS.
- 2) PACKAGE LENGTH DOES NOT INCLUDE MOLD FLASH, PROTRUSION OR GATE BURR.
- 3) PACKAGE WIDTH DOES NOT INCLUDE INTERLEAD FLASH OR PROTRUSION.
- 4) LEAD COPLANARITY (BOTTOM OF LEADS AFTER FORMING) SHALL BE 0.10 MILLIMETERS MAX.
- 5) DRAWING CONFORMS TO JEDEC MO-193, VARIATION AB.
- 6) DRAWING IS NOT TO SCALE.
- 7) PIN 1 IS LOWER LEFT PIN WHEN READING TOP MARK FROM LEFT TO RIGHT, (SEE EXAMPLE TOP MARK)

NOTICE: The information in this document is subject to change without notice. Users should warrant and guarantee that third party Intellectual Property rights are not infringed upon when integrating MPS products into any application. MPS will not assume any legal responsibility for any said applications.

Looking for pricing, stock, or lifecycle information?

Click below to explore more details on WIN SOURCE:

- ⊖ [View MC9S12XDP512MAL on WIN SOURCE](#)
- ⊖ [Freescale Semiconductor - NXP Information](#)

Optimize Your Supply Chain with WIN SOURCE Solutions

- ✓ Global Sourcing Solution
- ✓ Obsolete Management
- ✓ Cost Control Management
- ✓ Shortage Management
- ✓ Alternative Solution
- ✓ Excess Inventory Management