



**THE DATASHEET OF
MC9S08MP16VLC**



MC9S08MP16 Series Data Sheet

Features

- 8-Bit HCS08 Central Processor Unit (CPU)
 - Up to 51.34 MHz CPU at 2.7V to 5.5V across temperature range of -40°C to 105°C
 - Up to 40 MHz CPU at 2.7V to 5.5V across temperature range of -40°C to 125°C
 - HC08 instruction set with added BGND instruction and additional addressing modes for LDHX and STHX
 - Support for up to 48 interrupt/reset sources
- On-Chip Memory
 - Up to 16 KB flash memory; read/program/erase over full operating voltage and temperature
 - Up to 1 KB random-access memory (RAM)
 - Security circuitry to prevent unauthorized access to RAM and flash memory contents
- Power-Saving Modes
 - Two low power stop modes; reduced power wait mode
 - Peripheral clock gating can disable clocks to unused modules
- Clock Source Options
 - Oscillator (XOSC) — Loop-control Pierce oscillator; Crystal or ceramic resonator range of 31.25–38.4 kHz or 1–16 MHz
 - Internal Clock Source (ICS) — Containing a frequency-locked-loop (FLL) controlled by internal or external reference; precision trimming of internal reference allows 0.2% resolutions and 2% deviation over temperature and voltage; supports CPU frequencies up to 51.34 MHz
- System Protection
 - Watchdog computer operating properly (COP) reset running from dedicated 1-kHz internal clock source or bus clock
 - Low-voltage detection with reset or interrupt; selectable trip points
 - Illegal opcode and illegal address detection with reset
 - Flash memory block protection
- Development Support
 - Single-wire background debug interface
 - Breakpoint capability to allow single breakpoint setting during in-circuit debugging (plus three more breakpoints in on-chip debug module)
 - On-chip in-circuit emulator (ICE) debug module containing three comparators and nine trigger modes. Eight deep FIFO for storing change-of-flow addresses and event-only data. Debug module supports both tag and force breakpoints
- Peripherals
 - **IPC** — Interrupt Priority Controller with 4 programmable interrupt priority levels
 - **ADC** — 13-channel, 12-bit resolution; 2.5 μs conversion time; automatic compare function; 1.7 $\text{mV}/^{\circ}\text{C}$ temperature sensor; internal bandgap reference channel; operation in stop3



48-LQFP
Case 932-03



32-LQFP
Case 873A-03



28-SOIC
Case 751F-05

- **PGA** — Differential programmable gain amplifier with programmable gain (x1, x2, x4, x8, x16, or x32)
- **HSCMP** — Three fast analog comparators with positive and negative inputs; separately selectable interrupt on rising and falling comparator output; filtering; windowing; HSCMP1 and HSCMP2 outputs can be optionally routed to FTM1 module; runs in stop3
- **DAC** — Three 5-bit digital to analog convertor used as a 32-tap voltage reference for each comparator
- **PDB** — Two programmable delay blocks: PDB1 synchronizes PWM with samples of ADC; PDB2 synchronizes PWM with comparing window of analog comparators
- **SCI** — Full duplex non-return to zero (NRZ); LIN master extended break generation; LIN slave extended break detection; wake up on active edge
- **SPI** — Full-duplex or single-wire bidirectional; Double-buffered transmit and receive; Master or Slave mode; MSB-first or LSB-first shifting
- **IIC/SMBus** — Up to 400 kbps; Multi-master operation; Programmable slave address; Interrupt driven byte-by-byte data transfer; supports broadcast mode and 10-bit addressing; SMBus compatible
- **FTM** — Two Fleximers with total of 8 channels; One 2-channel (FTM1) and one 6-channel (FTM2); supports operation up to 2x bus clock; selectable input capture, output compare, edge- or center-aligned PWM; dead time insertion; fault inputs
- **MTIM** — 8-bit modulo counter with 8-bit prescaler
- **RTC** — (Real-time counter) 8-bit modulus counter with binary or decimal based prescaler; External clock source for precise time base, time-of-day, calendar or task scheduling; Free running on-chip low power oscillator (1 kHz) for cyclic wake-up without external components, runs in all MCU modes
- **CRC** — Cyclic redundancy check generator
- **KBI** — Three 8 channel keyboard interrupt module with software selectable polarity on edge or edge/level modes
- Input/Output
 - 40 GPIOs, 2 output-only pins.
 - Hysteresis and configurable pull up device on input pins; Configurable slew rate and drive strength on output pins; Sink/Source current up to 20mA
- Package Options
 - 48-LQFP, 32-LQFP, 28-SOIC
 - 48-LQFP qualified for automotive usage

Freescale reserves the right to change the detail specifications as may be required to permit improvements in the design of its products.

Table of Contents

1	Pin Assignments	4	2.13	Programmable Gain Amplifier (PGA) Characteristics	26
2	Electrical Characteristics	8	2.14	AC Characteristics	27
	2.1	Introduction		2.14.1	Control Timing
	2.2	Parameter Classification		2.14.2	FTM Module Timing
	2.3	Absolute Maximum Ratings		2.14.3	MTIM Module Timing
	2.4	Thermal Characteristics		2.14.4	SPI
	2.5	ESD Protection and Latch-Up Immunity		2.15	Flash Memory Specifications
	2.6	DC Characteristics		2.16	EMC Performance
	2.7	Supply Current Characteristics		2.16.1	Radiated Emissions
	2.8	External Oscillator (XOSC) Characteristics	3	Ordering Information	34
	2.9	Internal Clock Source (ICS) Characteristics		3.1	Device Numbering Scheme
	2.10	ADC Characteristics	4	Package Information	35
	2.11	Digital to Analog (DAC) Characteristics	5	Related Documentation	35
	2.12	High Speed Comparator (HSCMP) Characteristics	6	Revision History	35

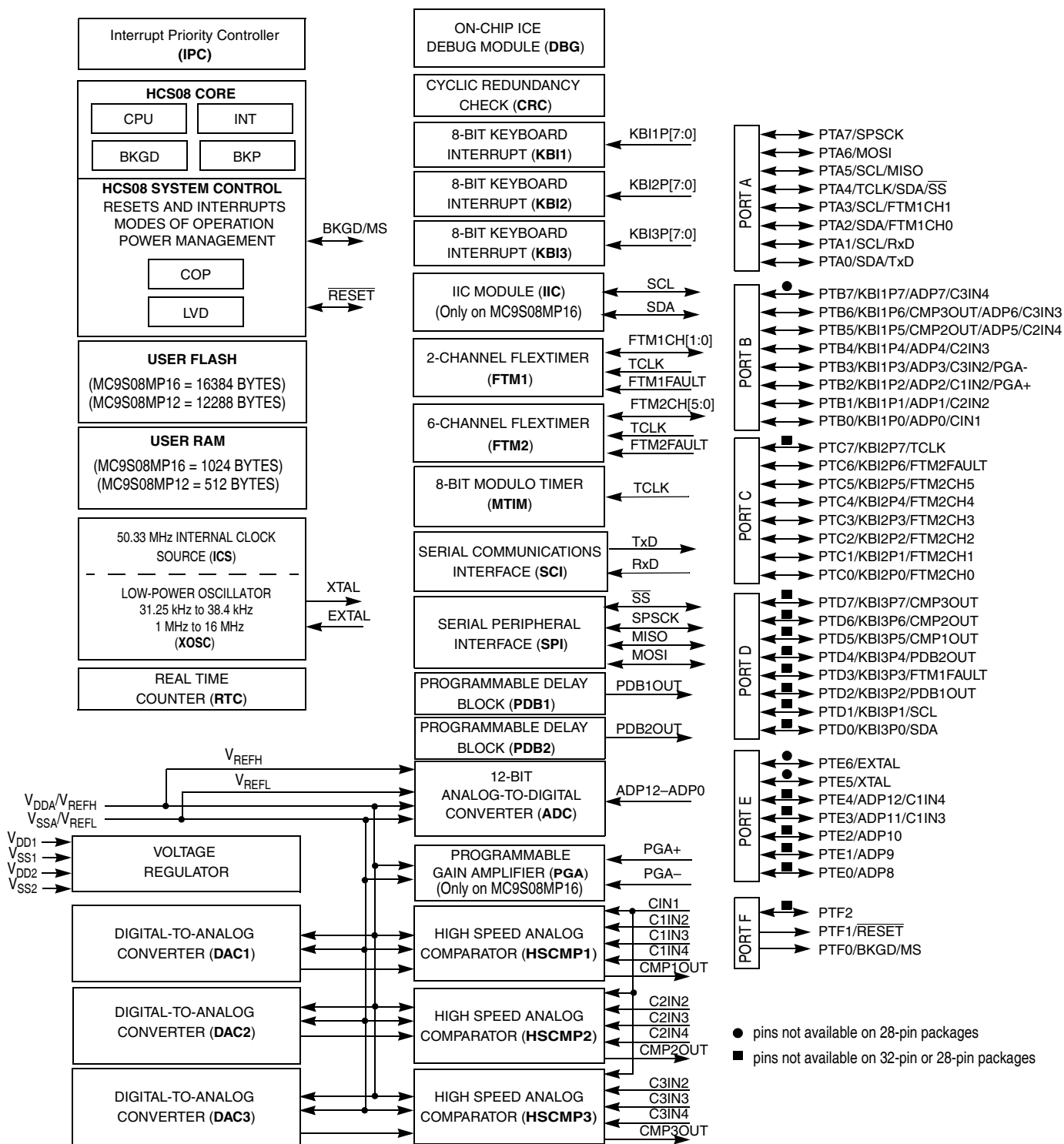

Notes: When PTF1 is configured as $\overline{\text{RESET}}$, pin becomes bi-directional with output being open-drain drive containing an internal pull-up device.
 When PTF0 is configured as BKGD, pin becomes bi-directional.
 V_{DD2} pad is tied internally on 32-pin and 28-pin packages,
 V_{SS2} pad is tied internally on 28-pin packages

Figure 1. MC9S08MP16 Series Block Diagram

1 Pin Assignments

This section shows the pin assignments for the MC9S08MP16 Series devices.

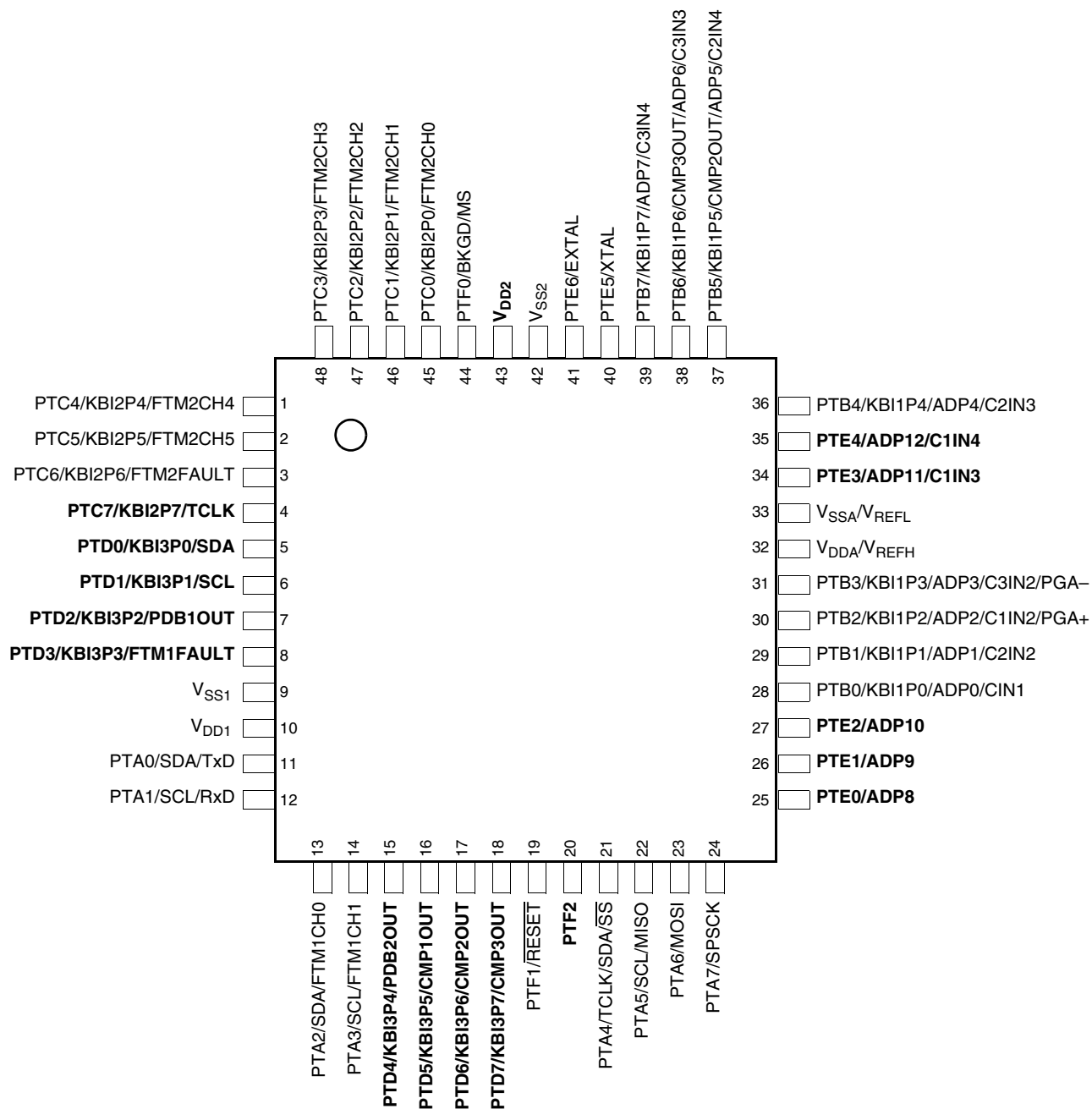

Note: Pins in **bold** are lost in the next lower pin count package.

Figure 2. MC9S08MP16 Series in 48-LQFP

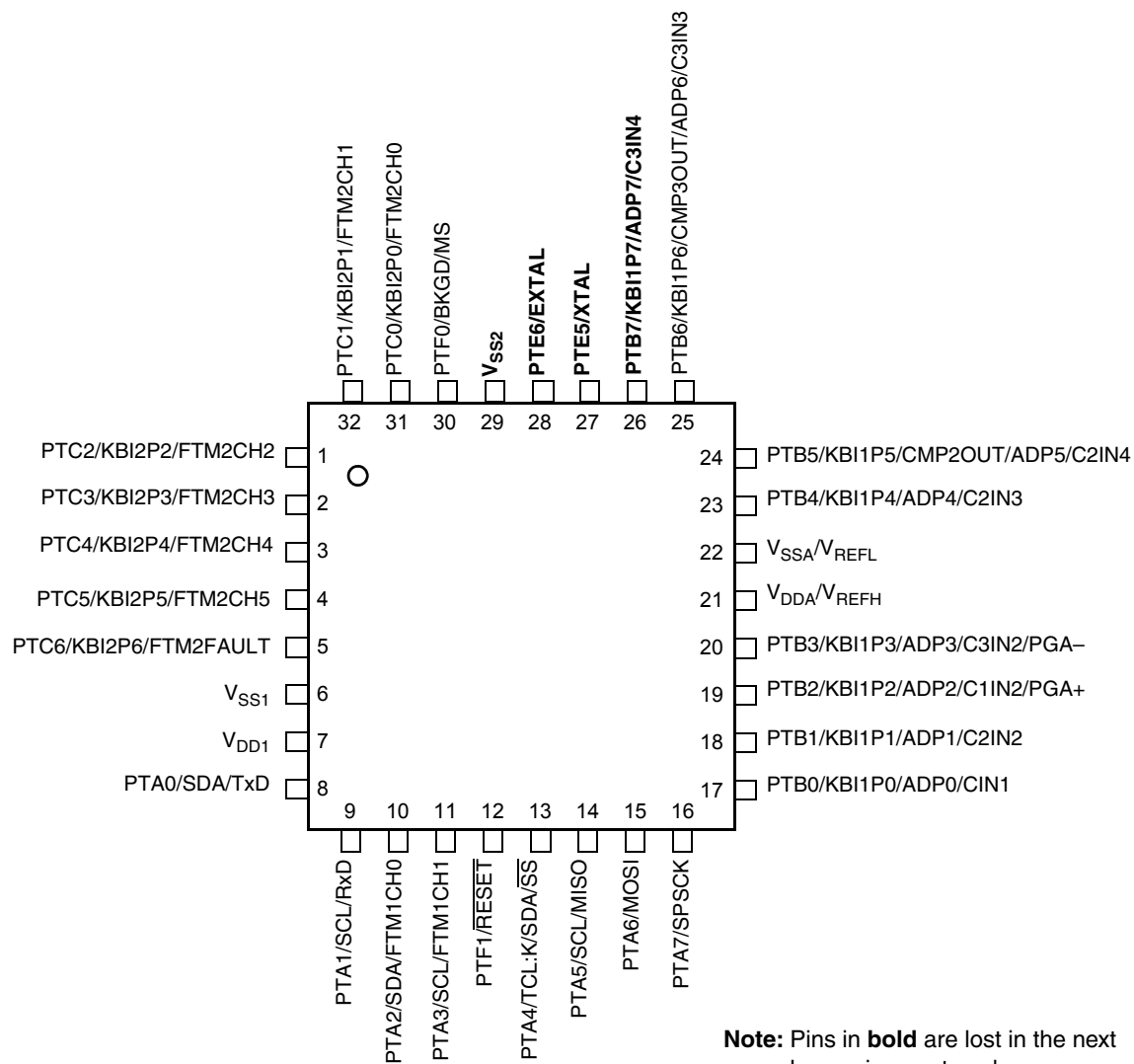

Figure 3. MC9S08MP16 Series in 32-Pin LQFP Package

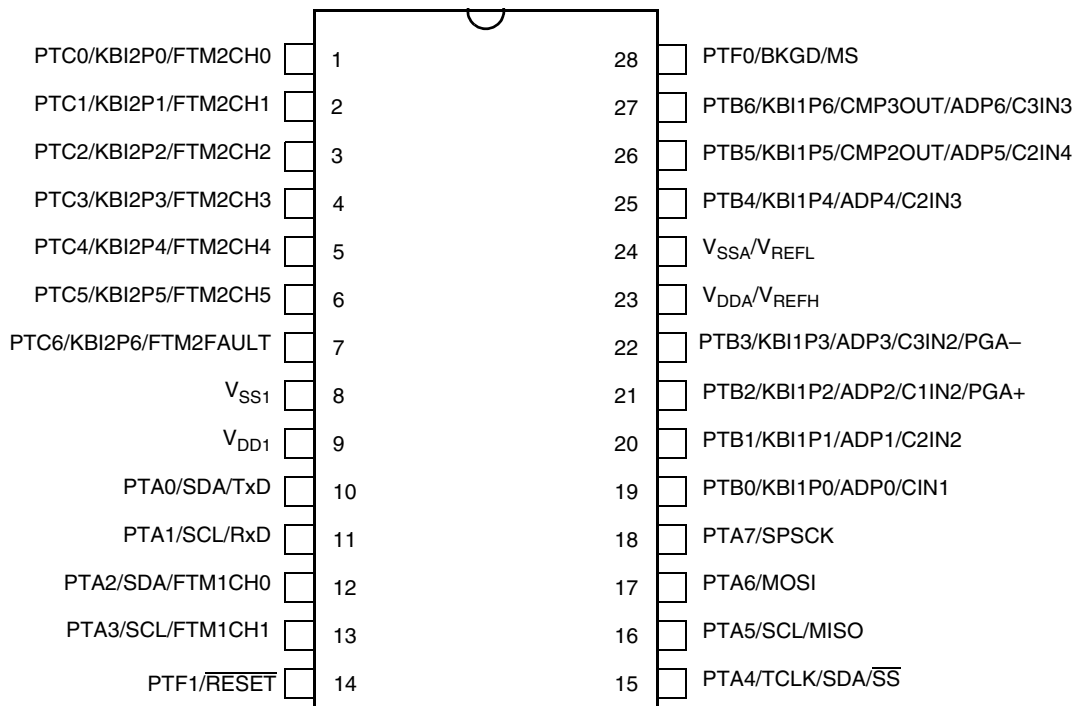

Figure 4. MC9S08MP16 Series in 28-Pin SOIC Package

Table 1. Pin Availability by Package Pin-Count

Pin Number			<-- Lowest Priority --> Highest				
48	32 LQFP	28	Port Pin	Alt 1	Alt 2	Alt3	Alt4
1	3	5	PTC4	KBI2P4	FTM2CH4		
2	4	6	PTC5	KBI2P5	FTM2CH5		
3	5	7	PTC6	KBI2P6	FTM2FAULT		
4	—	—	PTC7	KBI2P7	TCLK ¹		
5	—	—	PTD0	KBI3P0	SDA ⁵		
6	—	—	PTD1	KBI3P1	SCL ⁵		
7	—	—	PTD2	KBI3P2	PDB1OUT		
8	—	—	PTD3	KBI3P3	FTM1FAULT		
9	6	8					V _{SS1}
10	7	9					V _{DD1}
11	8	10	PTA0	SDA ⁵	TxD		
12	9	11	PTA1	SCL ⁵	RxD		
13	10	12	PTA2	SDA ⁵	FTM1CH0		
14	11	13	PTA3	SCL ⁵	FTM1CH1		
15	—	—	PTD4	KBI3P4	PDB2OUT		
16	—	—	PTD5	KBI3P5	CMP1OUT		
17	—	—	PTD6	KBI3P6	CMP2OUT ²		
18	—	—	PTD7	KBI3P7	CMP3OUT ³		
19	12	14	PTF1	$\overline{\text{RESET}}$ ⁴			
20	—	—	PTF2				
21	13	15	PTA4	TCLK ¹	SDA ⁵	$\overline{\text{SS}}$	
22	14	16	PTA5		SCL ⁵	MISO	
23	15	17	PTA6			MOSI	
24	16	18	PTA7			SPSCK	
25	—	—	PTE0		ADP8		
26	—	—	PTE1		ADP9		
27	—	—	PTE2		ADP10		
28	17	19	PTB0	KBI1P0	ADP0 ⁶	CIN1 ⁶	
29	18	20	PTB1	KBI1P1	ADP1 ⁶	C2IN2 ⁶	
30	19	21	PTB2	KBI1P2	ADP2 ⁶	C1IN2 ⁶	PGA+ ⁶
31	20	22	PTB3	KBI1P3	ADP3 ⁶	C3IN2 ⁶	PGA- ⁶
32	21	23					V _{DDA} /V _{REFH}
33	22	24					V _{SSA} /V _{REFL}
34	—	—	PTE3		ADP11 ⁶	C1IN3 ⁶	

Table 1. Pin Availability by Package Pin-Count (continued)

Pin Number			<-- Lowest Priority --> Highest				
48	32 LQFP	28	Port Pin	Alt 1	Alt 2	Alt3	Alt4
35	—	—	PTE4		ADP12 ⁶	C1IN4 ⁶	
36	23	25	PTB4	KBI1P4		ADP4 ⁶	C2IN3 ⁶
37	24	26	PTB5	KBI1P5	CMP2OUT ²	ADP5 ⁶	C2IN4 ⁶
38	25	27	PTB6	KBI1P6	CMP3OUT ³	ADP6 ⁶	C3IN3 ⁶
39	26	—	PTB7	KBI1P7		ADP7 ⁶	C3IN4 ⁶
40	27	—	PTE5	XTAL			
41	28	—	PTE6	EXTAL			
42	29	—					V _{SS2}
43	—	—					V _{DD2}
44	30	28	PTF0	BKGD	MS		
45	31	1	PTC0	KBI2P0	FTM2CH0		
46	32	2	PTC1	KBI2P1	FTM2CH1		
47	1	3	PTC2	KBI2P2	FTM2CH2		
48	2	4	PTC3	KBI2P3	FTM2CH3		

- ¹ TCLK pin can be repositioned using TCLKPS in SOPT2. Default reset location is PTC7.
- ² HSCMP2 output CMP2OUT can be repositioned using the CMP2OPS in the SOPT2 register. Default reset location is PTD6.
- ³ HSCMP3 output CMP3OUT can be repositioned using the CMP3OPS in the SOPT2 register. Default reset location is PTD7.
- ⁴ Pin is open drain with an internal pullup that is always enabled. Pin does not contain a clamp diode to V_{DD} and should not be driven above V_{DD}. The voltage measured on the internally pulled up $\overline{\text{RESET}}$ will not be pulled to V_{DD}. The internal gates connected to this pin are pulled to V_{DD}.
- ⁵ IIC pins SDA and SCL can be repositioned using IICPS in SOPT2. Default reset locations are PTD0 and PTD1.
- ⁶ If ADC, HSCMP, or PGA is enabling a shared analog input pin, each has access to the pin.

2 Electrical Characteristics

2.1 Introduction

This section contains electrical and timing specifications for the MC9S08MP16 Series of microcontrollers available at the time of publication.

2.2 Parameter Classification

The electrical parameters shown in this supplement are guaranteed by various methods. To give the customer a better understanding the following classification is used and the parameters are tagged accordingly in the tables where appropriate:

Table 2. Parameter Classifications

P	Those parameters that are guaranteed during production testing on each individual device.
C	Those parameters that are achieved by the design characterization by measuring a statistically relevant sample size across process variations.
T	Those parameters that are achieved by design characterization on a small sample size from typical devices under typical conditions unless otherwise noted. All values shown in the typical column are within this category.
D	Those parameters that are derived mainly from simulations.

NOTE

The classification is shown in the column labeled “C” in the parameter tables where appropriate.

2.3 Absolute Maximum Ratings

Absolute maximum ratings are stress ratings only, and functional operation at the maxima is not guaranteed. Stress beyond the limits specified in [Table 3](#) may affect device reliability or cause permanent damage to the device. For functional operating conditions, refer to the remaining tables in this section.

This device contains circuitry protecting against damage due to high static voltage or electrical fields; however, it is advised that normal precautions be taken to avoid application of any voltages higher than maximum-rated voltages to this high-impedance circuit. Reliability of operation is enhanced if unused inputs are tied to an appropriate logic voltage level (for instance, either V_{SS} or V_{DD}) or the programmable pull-up resistor associated with the pin is enabled.

Table 3. Absolute Maximum Ratings

Rating	Symbol	Value	Unit
Supply voltage	V_{DD}	-0.3 to +5.8	V
Maximum current into V_{DD}	I_{DD}	120	mA
Digital input voltage	V_{In}	-0.3 to $V_{DD} + 0.3$	V
Instantaneous maximum current Single pin limit (applies to all port pins) ^{1, 2, 3}	I_D	± 25	mA
Storage temperature range	T_{stg}	-55 to 150	°C

¹ Input must be current limited to the value specified. To determine the value of the required current-limiting resistor, calculate resistance values for positive (V_{DD}) and negative (V_{SS}) clamp voltages, then use the larger of the two resistance values.

² All functional non-supply pins, except for PTF1/RESET are internally clamped to V_{SS} and V_{DD} .

³ Power supply must maintain regulation within operating V_{DD} range during instantaneous and operating maximum current conditions. If positive injection current ($V_{In} > V_{DD}$) is greater than I_{DD} , the injection current may flow out of V_{DD} and could result in external power supply going out of regulation. Ensure external V_{DD} load will shunt current greater than maximum injection current. This will be the greatest risk when the MCU is not consuming power. Examples are: if no system clock is present, or if the clock rate is very low (which would reduce overall power consumption).

2.4 Thermal Characteristics

This section provides information about operating temperature range, power dissipation, and package thermal resistance. Power dissipation on I/O pins is usually small compared to the power dissipation in on-chip logic and voltage regulator circuits, and it is user-determined rather than being controlled by the MCU design. To take $P_{I/O}$ into account in power calculations, determine the difference between actual pin voltage and V_{SS} or V_{DD} and multiply by the pin current for each I/O pin. Except in cases of unusually high pin current (heavy loads), the difference between pin voltage and V_{SS} or V_{DD} will be very small.

Table 4. Thermal Characteristics

Num	C	Rating	Symbol	Consumer & Industrial	Automotive	Unit	
1	—	Operating temperature range (packaged)	T_A	–40 to 105	–40 to 125	°C	
2	D	Maximum junction temperature	T_J	115	135	°C	
3	D	Thermal resistance ^{1,2} single-layer board					°C/W
		48-pin LQFP	θ_{JA}	80	80		
		32-pin LQFP		85	—		
		28-pin SOIC		71	—		
4	D	Thermal resistance ^{1,2} four-layer board					°C/W
		48-pin LQFP	θ_{JA}	56	56		
		32-pin LQFP		57	—		
		28-pin SOIC		48	—		

¹ Junction temperature is a function of die size, on-chip power dissipation, package thermal resistance, mounting site (board) temperature, ambient temperature, air flow, power dissipation of other components on the board, and board thermal resistance.

² Junction-to-ambient natural convection

The average chip-junction temperature (T_J) in °C can be obtained from:

$$T_J = T_A + (P_D \times \theta_{JA}) \quad \text{Eqn. 1}$$

where:

T_A = Ambient temperature, °C

θ_{JA} = Package thermal resistance, junction-to-ambient, °C/W

$P_D = P_{int} + P_{I/O}$

$P_{int} = I_{DD} \times V_{DD}$, Watts — chip internal power

$P_{I/O}$ = Power dissipation on input and output pins — user determined

For most applications, $P_{I/O} \ll P_{int}$ and can be neglected. An approximate relationship between P_D and T_J (if $P_{I/O}$ is neglected) is:

$$P_D = K \div (T_J + 273^\circ\text{C}) \quad \text{Eqn. 2}$$

Solving Equation 1 and Equation 2 for K gives:

$$K = P_D \times (T_A + 273^\circ\text{C}) + \theta_{JA} \times (P_D)^2 \quad \text{Eqn. 3}$$

where K is a constant pertaining to the particular part. K can be determined from equation 3 by measuring P_D (at equilibrium) for a known T_A . Using this value of K, the values of P_D and T_J can be obtained by solving Equation 1 and Equation 2 iteratively for any value of T_A .

2.5 ESD Protection and Latch-Up Immunity

Although damage from electrostatic discharge (ESD) is much less common on these devices than on early CMOS circuits, normal handling precautions should be taken to avoid exposure to static discharge. Qualification tests are performed to ensure that these devices can withstand exposure to reasonable levels of static without suffering any permanent damage.

All ESD testing is in conformity with AEC-Q100 Stress Test Qualification for Automotive Grade Integrated Circuits. During the device qualification, ESD stresses were performed for the human body model (HBM) and the charge device model (CDM).

A device is defined as a failure if after exposure to ESD pulses the device no longer meets the device specification. Complete DC parametric and functional testing is performed per the applicable device specification at room temperature followed by hot temperature, unless instructed otherwise in the device specification.

Table 5. ESD and Latch-up Test Conditions

Model	Description	Symbol	Value	Unit
Human Body	Series resistance	R1	1500	Ω
	Storage capacitance	C	100	pF
	Number of pulses per pin	—	3	
Latch-up	Minimum input voltage limit		-2.5	V
	Maximum input voltage limit		7.5	V

Table 6. ESD and Latch-Up Protection Characteristics

No.	Rating ¹	Symbol	Min	Max	Unit
1	Human body model (HBM)	V_{HBM}	± 2000	—	V
2	Charge device model (CDM)	V_{CDM}	± 500	—	V
3	Latch-up current at $T_A = 125^\circ\text{C}$	I_{LAT}	± 100	—	mA

¹ Parameter is achieved by design characterization on a small sample size from typical devices under typical conditions unless otherwise noted.

2.6 DC Characteristics

This section includes information about power supply requirements and I/O pin characteristics.

Table 7. DC Characteristics

Num	C	Characteristic	Symbol	Condition	Min	Typ ¹	Max	Unit
1	—	Operating Voltage	V_{DD}		2.7	—	5.5	V
2	—	Analog Supply voltage delta to V_{DD} ($V_{DD} - V_{DDA}$) ⁽²⁾	ΔV_{DDA}		—	0	± 100	mV
3	—	Analog Ground voltage delta to V_{SS} ($V_{SS} - V_{SSA}$) ⁽²⁾	ΔV_{SSA}		—	0	± 100	mV

Table 7. DC Characteristics (continued)

Num	C	Characteristic	Symbol	Condition	Min	Typ ¹	Max	Unit		
4	C	All I/O pins (except PTF1/RESET) low-drive strength	V _{OH}	5 V, I _{Load} = -4 mA	V _{DD} - 1.5	—	—	V		
	P			5 V, I _{Load} = -2 mA	V _{DD} - 0.8	—	—			
	C			3 V, I _{Load} = -1 mA	V _{DD} - 0.8	—	—			
	C			5 V, I _{Load} = -20 mA	V _{DD} - 1.5	—	—			
	P			5 V, I _{Load} = -10 mA	V _{DD} - 0.8	—	—			
	C			3 V, I _{Load} = -5 mA	V _{DD} - 0.8	—	—			
5	D	Output high current Max total I _{OH} for all ports	I _{OHT}	V _{OUT} < V _{DD}	0	—	-100	mA		
6	C	All I/O pins (except PTF1/RESET) low-drive strength	V _{OL}	5 V, I _{Load} = 4 mA	—	—	1.5	V		
	P			5 V, I _{Load} = 2 mA	—	—	0.8			
	C			3 V, I _{Load} = 1 mA	—	—	0.8			
	C			All I/O pins	5 V, I _{Load} = 20 mA	—	—		1.5	
	P			Output low (Except PTF1/RESET)	5 V, I _{Load} = 10 mA	—	—		0.8	
	C			high-drive strength	3 V, I _{Load} = 5 mA	—	—		0.8	
	7			C	PTF1/RESET	5 V, I _{Load} = 3.2 mA	—		—	1.5
	8			P		5 V, I _{Load} = 1.6 mA	—		—	0.8
	9			C		3 V, I _{Load} = 0.8 mA	—		—	0.8
10	D	Output low current Max total I _{OL} for all ports	I _{OLT}	V _{OUT} > V _{SS}	0	—	100	mA		
11	P	Input high voltage; all digital inputs	V _{IH}	5V	0.65 x V _{DD}	—	—	V		
	C			3V	0.7 x V _{DD}	—	—			
12	P	Input low voltage; all digital inputs	V _{IL}	5V	—	—	0.35 x V _{DD}	V		
	C			3V	—	—	0.35 x V _{DD}			
13	C	Input hysteresis	V _{hys}		0.06 x V _{DD}			V		
14	P	Input leakage current (per pin)	I _{In}	V _{In} = V _{DD} or V _{SS}	—	—	1	μA		
15	P	Hi-Z (off-state) leakage current (per pin) input/output port pins	I _{OZ}	V _{In} = V _{DD} or V _{SS}	—	—	1	μA		
				PTF1/RESET, PTE5/XTAL pins	V _{In} = V _{DD} or V _{SS}	—	—		2	
16	P	Pullup or Pulldown ³ resistors; when enabled I/O pins	R _{PU} , R _{PD}		17	37	52	kΩ		
	C	PTF1/RESET ⁴	R _{PU}		17	37	52	kΩ		
17	D	DC injection current ^{5, 6, 7, 8} Single pin limit	I _{IC}	V _{IN} > V _{DD}	0	—	2	mA		
				V _{IN} < V _{SS}	0	—	-0.2	mA		
				V _{IN} > V _{DD}	0	—	25	mA		
				V _{IN} < V _{SS}	0	—	-5	mA		
		Total MCU limit, includes sum of all stressed pins								

Table 7. DC Characteristics (continued)

Num	C	Characteristic	Symbol	Condition	Min	Typ ¹	Max	Unit	
13	C	Input Capacitance, all pins	C_{In}		—	—	8	pF	
14	C	RAM retention voltage	V_{RAM}		—	0.6	1.0	V	
15	C	POR re-arm voltage ⁹	V_{POR}		0.9	1.4	2.0	V	
16	D	POR re-arm time	t_{POR}		10	—	—	μ s	
17	P	Low-voltage detection threshold — high range	V_{LVD1}		V_{DD} falling	3.9	4.0	4.1	V
					V_{DD} rising	4.0	4.1	4.2	
18	P	Low-voltage detection threshold — low range	V_{LVD0}		V_{DD} falling	2.48	2.56	2.64	V
					V_{DD} rising	2.54	2.62	2.70	
19	P	Low-voltage warning threshold — high range 1	V_{LVW3}		V_{DD} falling	4.5	4.6	4.7	V
					V_{DD} rising	4.6	4.7	4.8	
20	P	Low-voltage warning threshold — high range 0	V_{LVW2}		V_{DD} falling	4.2	4.3	4.4	V
					V_{DD} rising	4.3	4.4	4.5	
21	P	Low-voltage warning threshold low range 1	V_{LVW1}		V_{DD} falling	2.84	2.92	3.00	V
					V_{DD} rising	2.90	2.98	3.06	
22	P	Low-voltage warning threshold — low range 0	V_{LVW0}		V_{DD} falling	2.66	2.74	2.82	V
					V_{DD} rising	2.72	2.80	2.88	
23	T	Low-voltage inhibit reset/recover hysteresis	V_{hys}	5 V	—	100	—	mV	
				3 V	—	60	—		
24	P	Bandgap voltage reference at 25°C ¹⁰	V_{BG}		1.18	1.202	1.21	V	
25	P	Bandgap voltage reference across temperature range ¹⁰			1.17	—	1.22	V	

¹ Typical values are measured at 25°C. Characterized, not tested

² DC potential difference.

³ When keyboard interrupt is configured to detect rising edges, pulldown resistors are used in place of pullup resistors.

⁴ The specified resistor value is the actual value internal to the device. The pullup value may measure higher when measured externally on the pin.

⁵ Power supply must maintain regulation within operating V_{DD} range during instantaneous and operating maximum current conditions. If positive injection current ($V_{in} > V_{DD}$) is greater than I_{DD} , the injection current may flow out of V_{DD} and could result in external power supply going out of regulation. Ensure external V_{DD} load will shunt current greater than maximum injection current. This will be the greatest risk when the MCU is not consuming power. Examples are: if no system clock is present, or if clock rate is very low (which would reduce overall power consumption).

⁶ Input must be current limited to the value specified. To determine the value of the required current-limiting resistor, calculate resistance values for positive and negative clamp voltages, then use the larger of the two values.

Electrical Characteristics

- ⁷ All functional non-supply pins except PTF1/ $\overline{\text{RESET}}$ are internally clamped to V_{SS} and V_{DD} .
- ⁸ The PTF1/ $\overline{\text{RESET}}$ pin does not have a clamp diode to V_{DD} . Do not drive this pin above V_{DD} .
- ⁹ Maximum is highest voltage that POR is guaranteed.
- ¹⁰ Factory trimmed at $V_{DD} = 5.0\text{ V}$

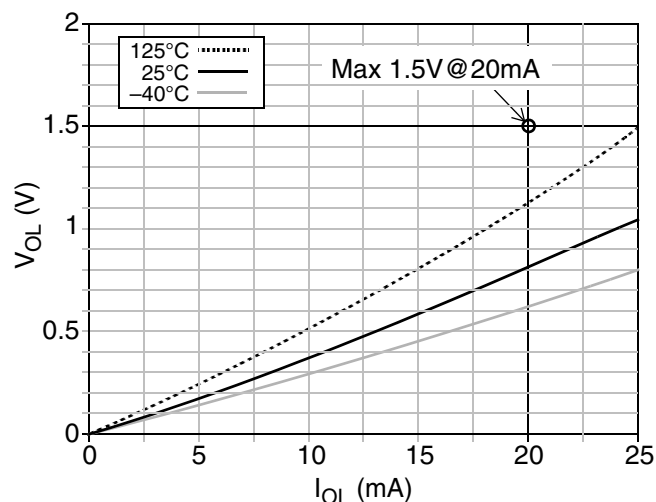

a) $V_{DD} = 5\text{V}$, High Drive

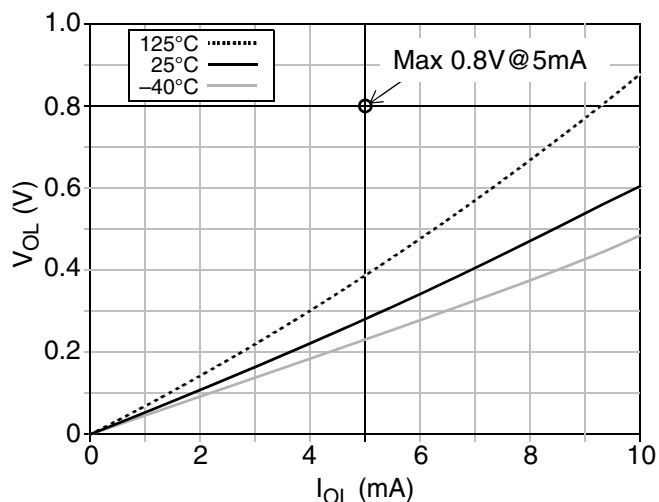

b) $V_{DD} = 3\text{V}$, High Drive

Figure 5. Typical V_{OL} vs I_{OL} , High Drive Strength (except PTF1/ $\overline{\text{RESET}}$)

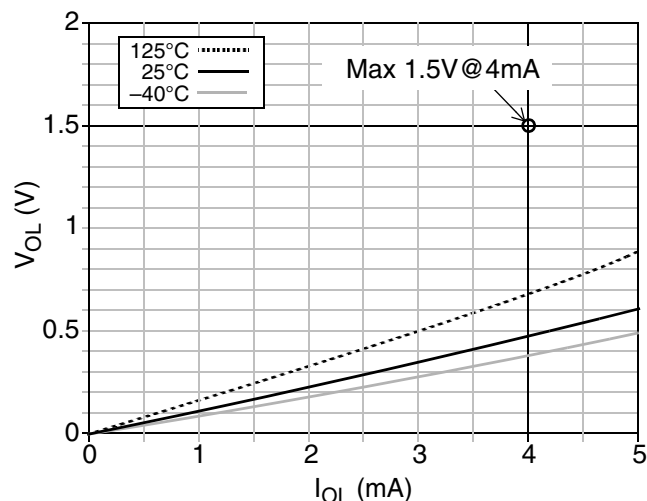

a) $V_{DD} = 5\text{V}$, Low Drive

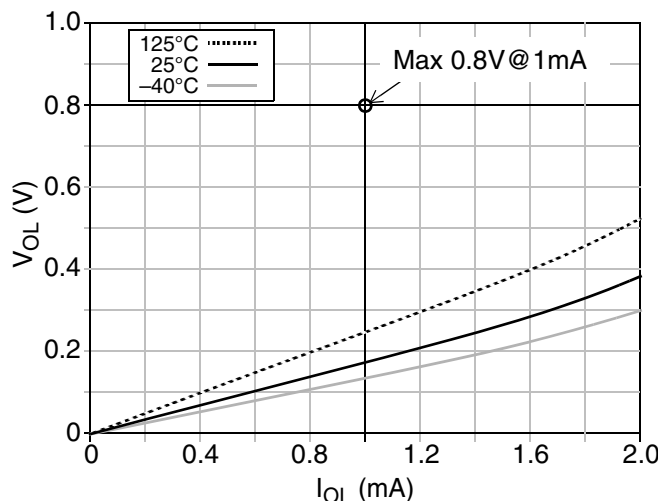

b) $V_{DD} = 3\text{V}$, Low Drive

Figure 6. Typical V_{OL} vs I_{OL} , Low Drive Strength (except PTF1/ $\overline{\text{RESET}}$)

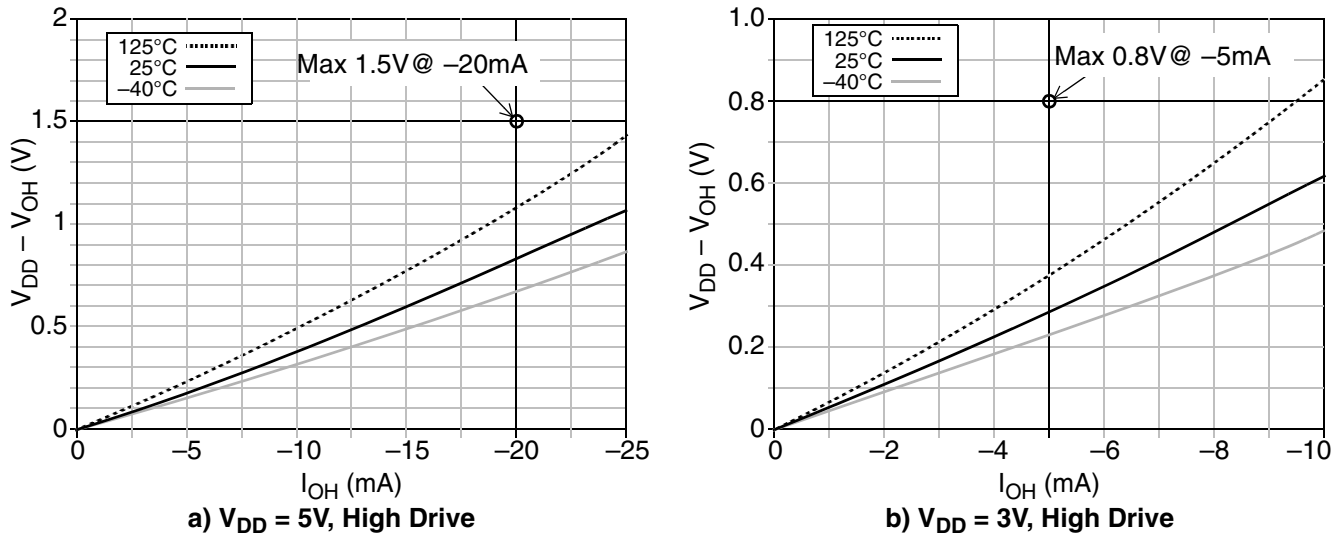

Figure 7. Typical $V_{DD} - V_{OH}$ vs I_{OH} , High Drive Strength

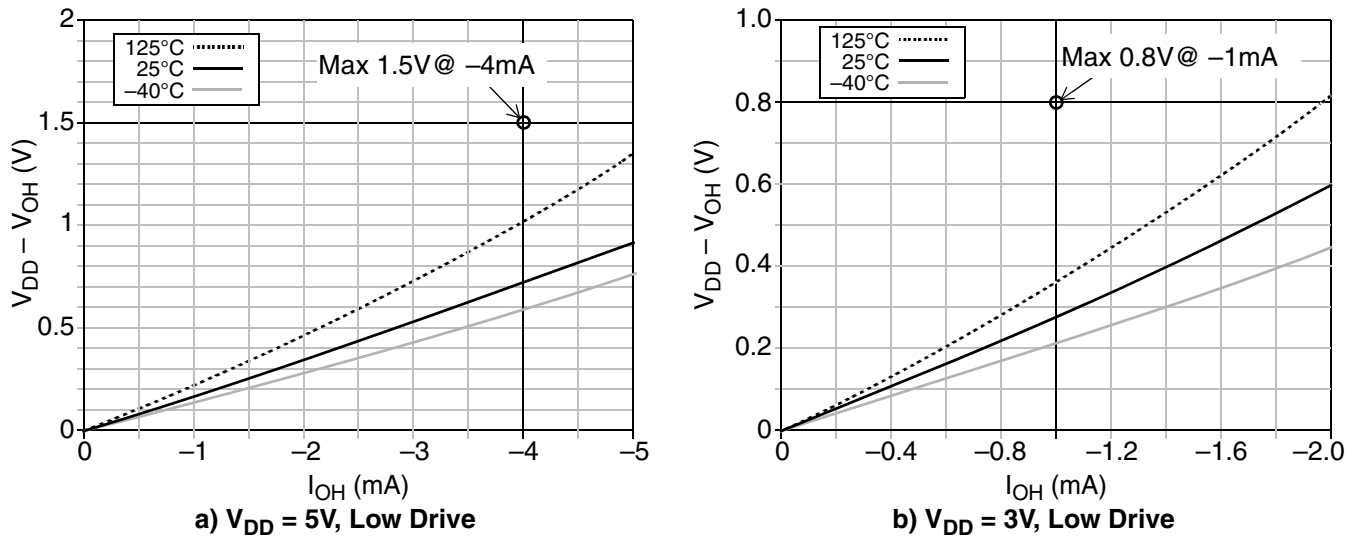

Figure 8. Typical $V_{DD} - V_{OH}$ vs I_{OH} , Low Drive Strength

2.7 Supply Current Characteristics

This section includes information about power supply current in various operating modes.

Table 8. Supply Current Characteristics

Num	C	Parameter	Symbol	V_{DD} (V)	Typ ¹	Max ²	Unit
1	C	Run supply current ³ measured at (CPU clock = 4 MHz, f_{Bus} = 2 MHz)	$R_{I_{DD}}$	5	2.16	3	mA
	3			1.8	2.5		
2	P	Run supply current ³ measured at (CPU clock = 16 MHz, f_{Bus} = 8 MHz)	$R_{I_{DD}}$	5	5.26	7.5	mA
	C			3	4.92	7	

Table 8. Supply Current Characteristics (continued)

Num	C	Parameter	Symbol	V _{DD} (V)	Typ ¹	Max ²	Unit	
3	C	Run supply current ⁴ measured at (CPU clock = 32 MHz, f _{Bus} = 16 MHz)	R _{I_{DD}}	5	9.4	10	mA	
	C			3	9	10		
4	P	Run supply current ⁵ measured at (CPU clock = 51.34 MHz, f _{Bus} = 25.67 MHz)	R _{I_{DD}}	5	14.3	30	mA	
	C			3	13.9	20		
5	P	Run supply current measured at (CPU clock = 40 MHz, f _{Bus} = 20 MHz)	R _{I_{DD}}	5	16	30	mA	
	—			3	—	—		
6	C	Wait mode supply current measured at (CPU clock = 8 MHz, f _{Bus} = 4 MHz) (FEI mode, all modules off)	W _{I_{DD}}	5	2.7	—	mA	
Stop3 mode supply current								
7	C	—40°C	S3I _{DD}	5	0.96	—	μA	
	P				25°C	1.3		—
	C				85°C	7.5		25
	p ⁶				105°C	37		90
	P				125°C	65		150
	C	—40°C		3	0.85	—	μA	
	P				25°C	1.2		—
	C				85°C	6.5		20
	p ⁶				105°C	32.7		80
	P				125°C	58		130
Stop2 mode supply current								
8	C	—40°C	S2I _{DD}	5	0.94	—	μA	
	P				25°C	1.25		—
	C				85°C	7		25
	p ⁶				105°C	30		65
	P				125°C	64		120
	C	—40°C		3	0.83	—	μA	
	P				25°C	1.1		—
	C				85°C	6.3		20
	p ⁶				105°C	25		55
	P				125°C	57		100
9	C	RTC adder to stop2 or stop3 ⁷	S23I _{DDRTC}	5	300	500	nA	
				3	300	500	nA	

Table 8. Supply Current Characteristics (continued)

Num	C	Parameter	Symbol	V _{DD} (V)	Typ ¹	Max ²	Unit
10	C	LVD adder to stop3 (LVDE = LVDSE = 1)	S3I _{DDLVD}	5	110	180	μA
				3	90	160	μA
11	C	Adder to stop3 for oscillator enabled ⁸ (EREFSTEN = 1)	S3I _{DDOSC}	5,3	5	8	μA

¹ Typical values are based on characterization data at 25°C. See Figure 9 through Figure 14 for typical curves across temperature and voltage.

² Max values in this column apply for the full operating temperature range of the device unless otherwise noted.

³ All modules except ADC active, ICS configured for FBELP, and does not include any dc loads on port pins

⁴ All modules except ADC active, ICS configured for FEI, and does not include any dc loads on port pins

⁵ All modules except ADC active, ICS configured for FEI, and does not include any dc loads on port pins

⁶ Stop currents are tested in production for 25°C on all parts. Tests at other temperatures depend upon the part number suffix and maturity of the product. Freescale may eliminate a test insertion at a particular temperature from the production test flow once sufficient data has been collected and is approved.

⁷ Most customers are expected to find that auto-wakeup from stop2 or stop3 can be used instead of the higher current wait mode.

⁸ Values given under the following conditions: low range operation (RANGE = 0) with a 32.768kHz crystal and low power mode (HGO = 0).

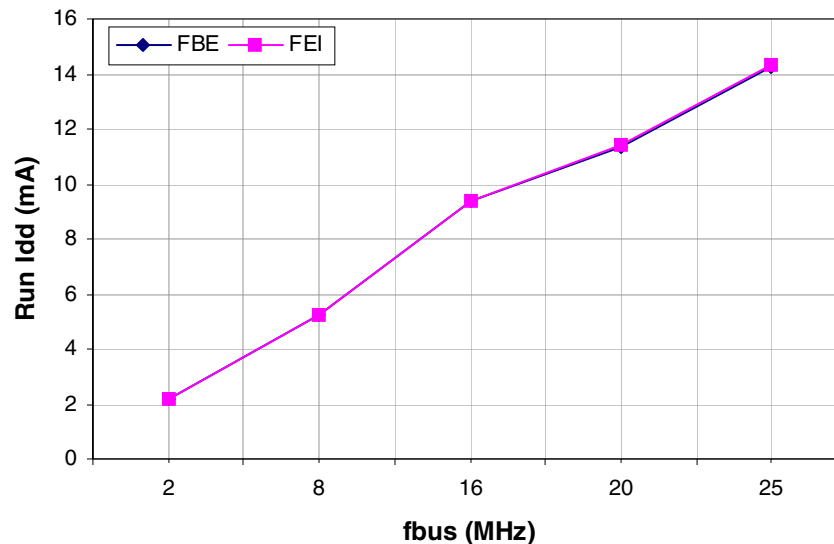
 Figure 9. Typical Run I_{DD} vs. Bus Frequency (V_{DD} = 5V)

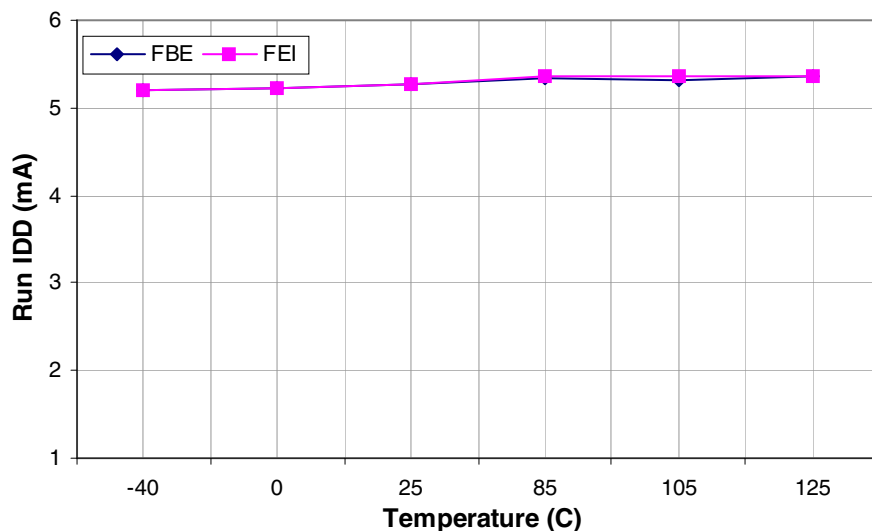

Figure 10. Typical Run I_{DD} vs. Temperature ($V_{DD} = 5V$, $f_{bus} = 8MHz$)

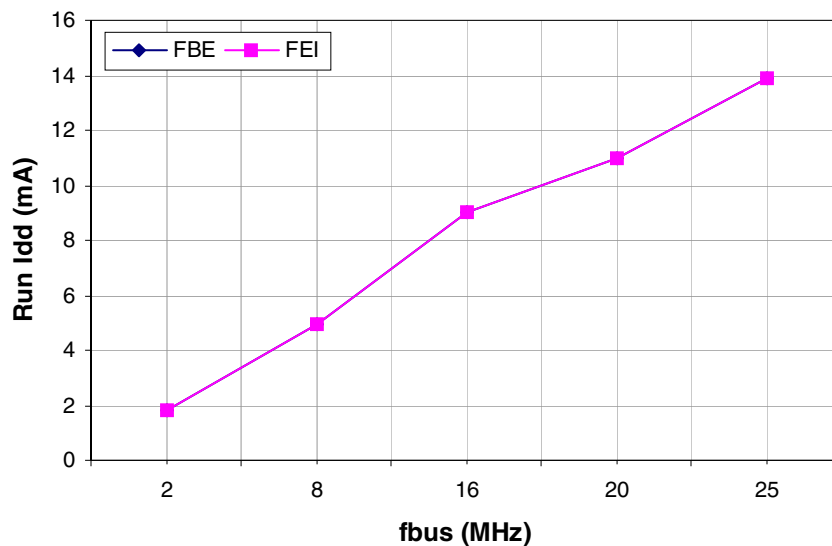

Figure 11. Typical Run I_{DD} vs. Bus Frequency ($V_{DD} = 3V$)

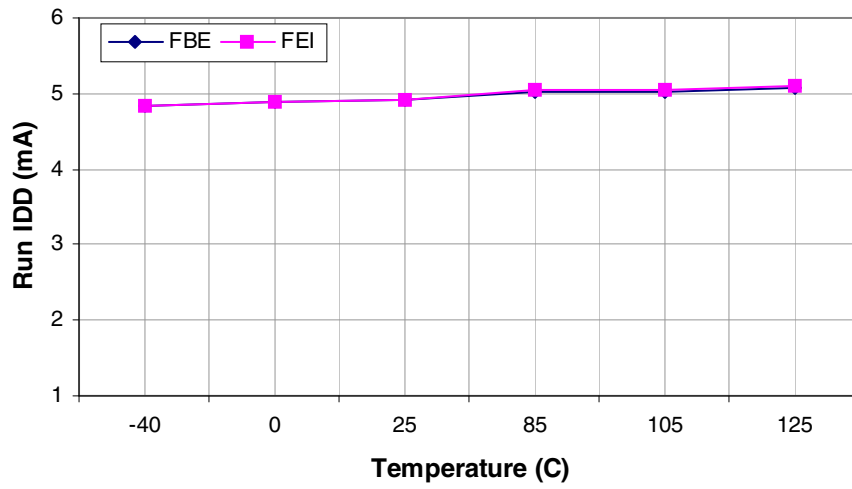

Figure 12. Typical Run I_{DD} vs. Temperature (V_{DD} = 3V, f_{bus} = 8MHz)

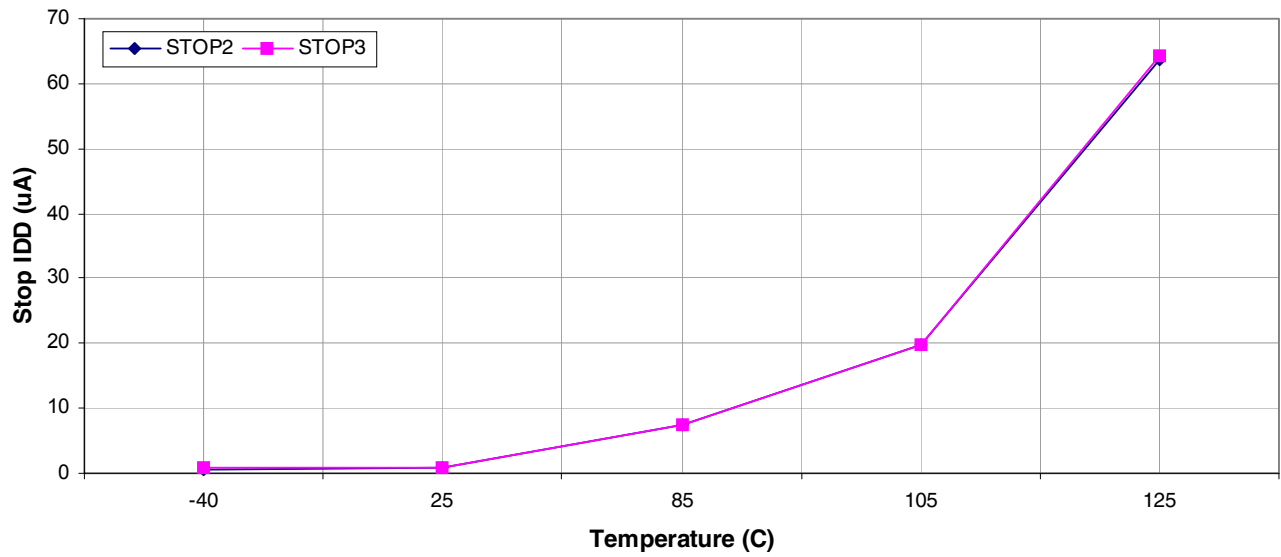

Figure 13. Typical Stop I_{DD} vs. Temperature (V_{DD} = 5V)

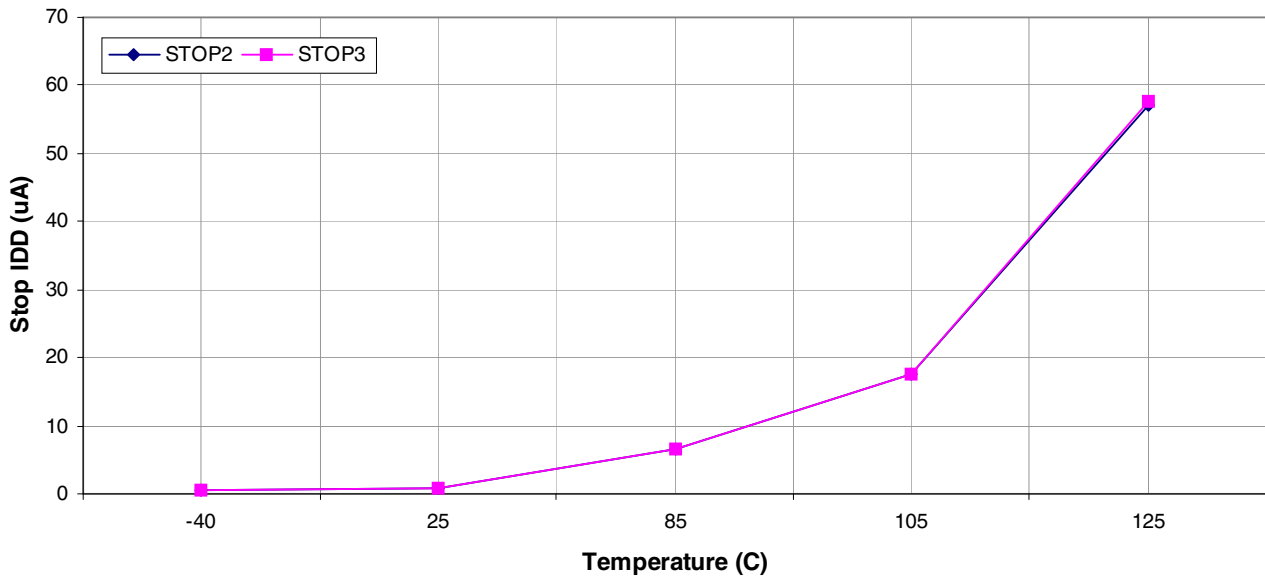

Figure 14. Typical Stop I_{DD} vs. Temperature (V_{DD} = 3V)

2.8 External Oscillator (XOSC) Characteristics

Table 9. Oscillator Electrical Specifications

Num	C	Rating	Symbol	Min	Typ ¹	Max	Unit
1	C	Oscillator crystal or resonator (EREFS = 1, ERCLKEN = 1)					
		Low range (RANGE = 0)	f _{lo}	32	—	38.4	kHz
		High range (RANGE = 1) FEE ² or FBE ³ mode	f _{hi}	1	—	16	MHz
		High range (RANGE = 1, HGO = 1) FBELP mode	f _{hi-hgo}	1	—	16	MHz
		High range (RANGE = 1, HGO = 0) FBELP mode	f _{hi-lp}	1	—	8	MHz
2	—	Load capacitors	C ₁ , C ₂	See crystal or resonator manufacturer's recommendation.			
3	—	Feedback resistor					
		Low range (32 kHz to 100 kHz)	R _F	—	10	—	MΩ
		High range (1 MHz to 16 MHz)		—	1	—	
4	—	Series resistor					
		Low range, low gain (RANGE = 0, HGO = 0)		—	0	—	
		Low range, high gain (RANGE = 0, HGO = 1)		—	100	—	
		High range, low gain (RANGE = 1, HGO = 0)		—	0	—	
		High range, high gain (RANGE = 1, HGO = 1)	R _S				
		≥ 8 MHz		—	0	0	
		4 MHz		—	0	10	
		1 MHz		—	0	20	

Table 9. Oscillator Electrical Specifications (continued)

Num	C	Rating	Symbol	Min	Typ ¹	Max	Unit
5	T	Crystal start-up time ⁴					
		Low range, low gain (RANGE = 0, HGO = 0)	$t_{\text{CSTL-LP}}$	—	200	—	ms
		Low range, high gain (RANGE = 0, HGO = 1)	$t_{\text{CSTL-HGO}}$	—	400	—	
		High range, low gain (RANGE = 1, HGO = 0) ⁵	$t_{\text{CSTH-LP}}$	—	5	—	
High range, high gain (RANGE = 1, HGO = 1) ⁴	$t_{\text{CSTH-HGO}}$	—	20	—			
6	T	Square wave input clock frequency (EREFS = 0, ERCLKEN = 1)					
		FEE mode ²	f_{extal}	0.03125	—	51.34	MHz
		FBE mode ³		0	—	51.34	MHz
		FBELP mode		0	—	51.34	MHz

¹ Typical data was characterized at 5.0 V, 25°C or is recommended value.

² The input clock source must be divided using RDIV to within the range of 31.25 kHz to 39.0625 kHz.

³ The input clock source must be divided using RDIV to less than or equal to 39.0625 kHz.

⁴ This parameter is characterized and not tested on each device. Proper PC board layout procedures must be followed to achieve specifications.

⁵ 4 MHz crystal

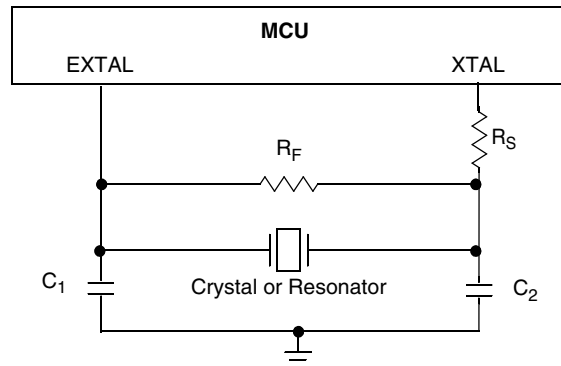

2.9 Internal Clock Source (ICS) Characteristics

Table 10. ICS Frequency Specifications

Num	C	Characteristic	Symbol	Min	Typ ¹	Max	Unit
1a	P	Average internal reference frequency — factory trimmed (consumer- and industrial-qualified devices) at $V_{\text{DD}} = 5\text{ V}$ and temperature = 25°C	$f_{\text{int_t}}$	—	32.768	—	kHz
1b	P	Average internal reference frequency — factory trimmed (automotive-qualified devices) at $V_{\text{DD}} = 5\text{ V}$ and temperature = 25°C	$f_{\text{int_t}}$	—	31.25	—	kHz
2	P	Internal reference frequency — user trimmed	$f_{\text{int_t}}$	31.25	—	39.06	kHz
3	T	Internal reference start-up time	t_{irefst}	—	60	100	μs

Table 10. ICS Frequency Specifications (continued)

Num	C	Characteristic	Symbol	Min	Typ ¹	Max	Unit
4	P	DCO output frequency range — trimmed ²	f_{dco_t}	16	—	20	MHz
	C			32	—	40	
	P			48	—	60	
5	P	DCO output frequency ² Reference = 32768 Hz and DMX32 = 1	f_{dco_DMX32}	—	19.92	—	MHz
	P			—	39.85	—	
	P			—	59.77	—	
6	C	Resolution of trimmed DCO output frequency at fixed voltage and temperature (using FTRIM)	$\Delta f_{dco_res_t}$	—	± 0.1	± 0.2	% f_{dco}
7	C	Resolution of trimmed DCO output frequency at fixed voltage and temperature (not using FTRIM)	$\Delta f_{dco_res_t}$	—	± 0.2	± 0.4	% f_{dco}
8	P	Total deviation of trimmed DCO output frequency over voltage and temperature	Δf_{dco_t}	—	± 0.8	± 2	% f_{dco}
9	C	Total deviation of trimmed DCO output frequency over fixed voltage and temperature range of 0°C to 70 °C	Δf_{dco_t}	—	± 0.5	± 1	% f_{dco}
10	C	FLL acquisition time ³	$t_{Acquire}$	—	—	1	ms
11	C	Long term jitter of DCO output clock (averaged over 2-ms interval) ⁴	C_{Jitter}	—	0.02	0.2	% f_{dco}

¹ Data in Typical column was characterized at 3.0 V, 25°C or is typical recommended value.

² The resulting bus clock frequency should not exceed the maximum specified bus clock frequency of the device.

³ This specification applies to any time the FLL reference source or reference divider is changed, trim value changed or changing from FLL disabled (FBELP, FBILP) to FLL enabled (FEI, FEE, FBE, FBI). If a crystal/resonator is being used as the reference, this specification assumes it is already running.

⁴ Jitter is the average deviation from the programmed frequency measured over the specified interval at maximum f_{Bus} . Measurements are made with the device powered by filtered supplies and clocked by a stable external clock signal. Noise injected into the FLL circuitry via V_{DD} and V_{SS} and variation in crystal oscillator frequency increase the C_{Jitter} percentage for a given interval.

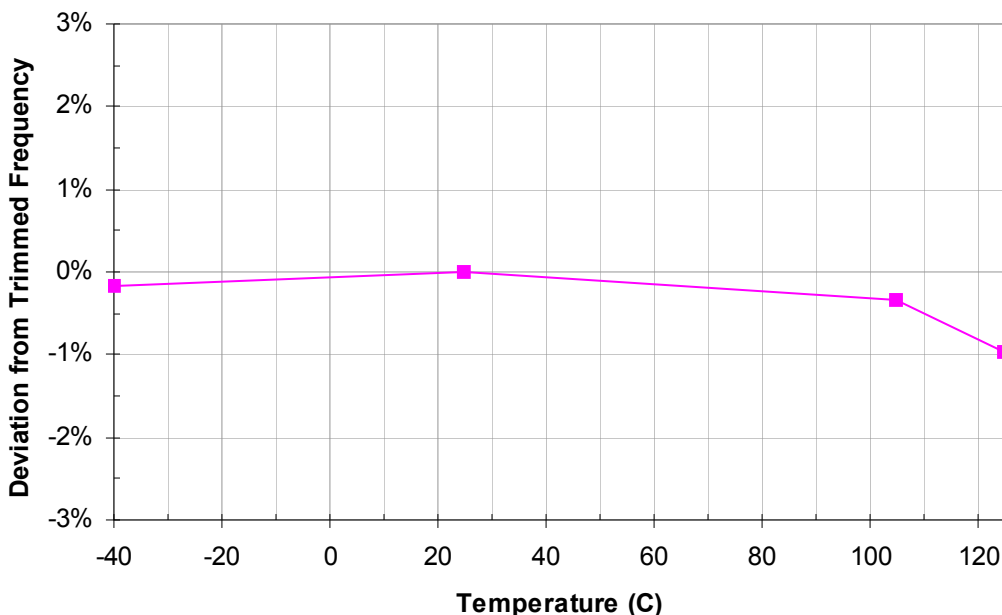

Figure 15. Typical Frequency Deviation vs Temperature (ICS Trimmed to 25 MHz bus@25°C, 5V, FEI)¹

2.10 ADC Characteristics

Table 11. 12-bit ADC Operating Conditions

Characteristic	Conditions	Symbol	Min	Typ ¹	Max	Unit	Comment
Supply voltage	Absolute	V_{DDA}	2.7	—	5.5	V	
Input Voltage		V_{ADIN}	V_{REFL}	—	V_{REFH}	V	
Input Capacitance		C_{ADIN}	—	4.5	5.5	pF	
Input Resistance		R_{ADIN}	—	3	5	k Ω	
Analog Source Resistance	12 bit mode $f_{ADCK} > 4\text{MHz}$ $f_{ADCK} < 4\text{MHz}$	R_{AS}	—	—	2	k Ω	External to MCU
	10 bit mode $f_{ADCK} > 4\text{MHz}$ $f_{ADCK} < 4\text{MHz}$		—	—	5		
	8 bit mode (all valid f_{ADCK})		—	—	10		
ADC Conversion Clock Freq.	High Speed (ADLPC=0)	f_{ADCK}	0.4	—	8.0	MHz	
	Low Power (ADLPC=1)		0.4	—	4.0		

¹ Typical values assume $V_{DDAD} = 5.0\text{V}$, Temp = 25°C, $f_{ADCK} = 1.0\text{MHz}$ unless otherwise stated. Typical values are for reference only and are not tested in production.

1. Based on the average of several hundred units from a typical characterization lot.

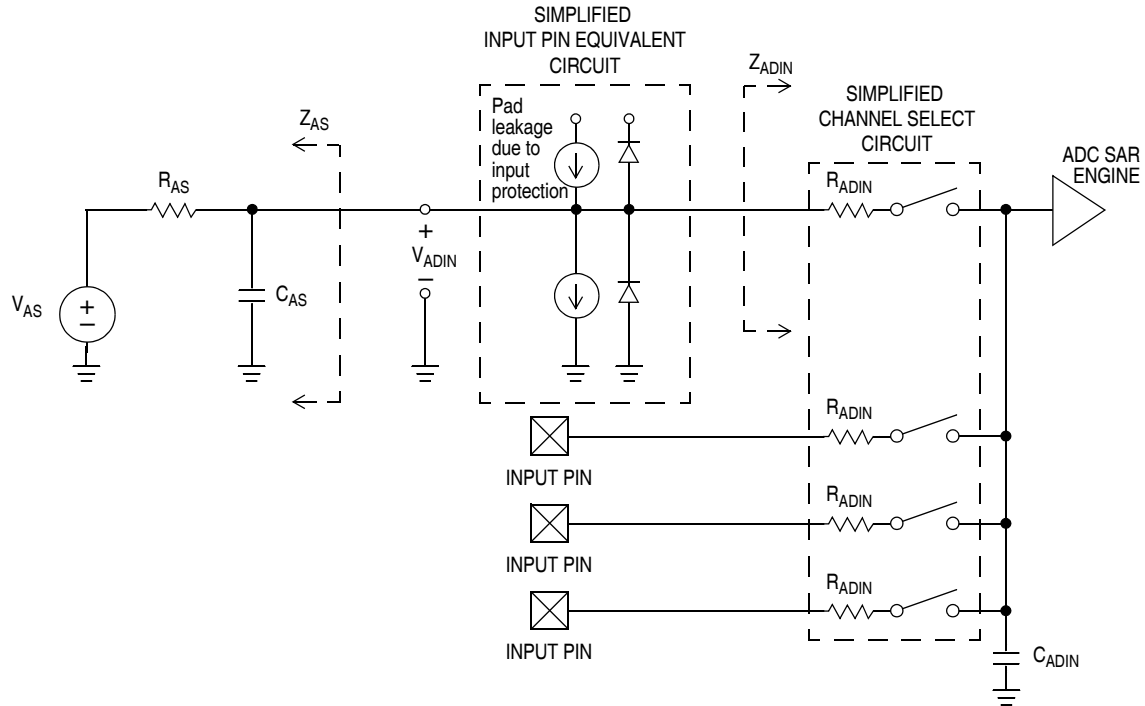

Figure 16. ADC Input Impedance Equivalency Diagram

Table 12. 12-bit ADC Characteristics ($V_{REFH} = V_{DDAD}$, $V_{REFL} = V_{SSAD}$)

C	Characteristic	Conditions	Symb	Min	Typ ¹	Max	Unit	Comment
T	Supply Current ADLPC=1 ADLSMP=1 ADCO=1		I_{DDA}	—	133	—	μA	
T	Supply Current ADLPC=1 ADLSMP=0 ADCO=1		I_{DDA}	—	218	—	μA	
T	Supply Current ADLPC=0 ADLSMP=1 ADCO=1		I_{DDA}	—	327	—	μA	
T	Supply Current ADLPC=0 ADLSMP=0 ADCO=1		I_{DDA}	—	0.582	—	mA	
P	ADC Asynchronous Clock Source	High Speed (ADLPC=0)	f_{ADACK}	2	3.3	5	MHz	$t_{ADACK} = 1/f_{ADACK}$
		Low Power (ADLPC=1)		1.25	2	3.3		

Table 12. 12-bit ADC Characteristics ($V_{REFH} = V_{DDAD}$, $V_{REFL} = V_{SSAD}$) (continued)

C	Characteristic	Conditions	Symb	Min	Typ ¹	Max	Unit	Comment
D	Conversion Time (Including sample time)	Short Sample (ADLSMP=0)	t_{ADC}	—	20	—	ADCK cycles	See ADC chapter in the Reference Manual for conversion time variances
		Long Sample (ADLSMP=1)		—	40	—		
D	Sample Time	Short Sample (ADLSMP=0)	t_{ADS}	—	3.5	—	ADCK cycles	
		Long Sample (ADLSMP=1)		—	23.5	—		
T	Temp Sensor Slope	-40°C to 25°C	m	—	3.266	—	mV/°C	
		25°C to 125°C		—	3.638	—		
T	Temp Sensor Voltage	25°C	V_{TEMP25}	—	1.396	—	mV	
T	Total Unadjusted Error	12 bit mode	E_{TUE}	—	±3.0	±6.5	LSB ²	Includes quantization
P		10 bit mode		—	±1	±2.5		
T		8 bit mode		—	±0.5	±1.0		
T	Differential Non-Linearity	12 bit mode	DNL	—	±1.75	±3.5	LSB ²	
P		10 bit mode ³		—	±0.5	±1.0		
T		8 bit mode ³		—	±0.3	±0.5		
T	Integral Non-Linearity	12 bit mode	INL	—	±1.5	±4.5	LSB ²	
P		10 bit mode		—	±0.5	±1.0		
T		8 bit mode		—	±0.3	±0.5		
T	Zero-Scale Error	12 bit mode	E_{ZS}	—	±1.5	0.0/ -3.0	LSB ²	$V_{ADIN} = V_{SSAD}$
P		10 bit mode		—	±0.5	±1.5		
T		8 bit mode		—	±0.5	±0.5		
T	Full-Scale Error	12 bit mode	E_{FS}	—	±1.0	+1.75/ -1.25	LSB ²	$V_{ADIN} = V_{DDAD}$
T		10 bit mode		—	±0.5	±1		
T		8 bit mode		—	±0.5	±0.5		
D	Quantization Error	12 bit mode	E_Q	—	-1 to 0	—	LSB ²	
		10 bit mode		—	—	±0.5		
		8 bit mode		—	—	±0.5		
D	Input Leakage Error	12 bit mode	E_{IL}	—	±1	—	LSB ²	Pad leakage ⁴ * R_{AS}
		10 bit mode		—	±0.2	±2.5		
		8 bit mode		—	±0.1	±1		

¹ Typical values assume $V_{DDAD} = 5.0V$, Temp = 25°C, $f_{ADCK} = 1.0MHz$ unless otherwise stated. Typical values are for reference only and are not tested in production.

² $1 \text{ LSB} = (V_{REFH} - V_{REFL})/2^N$

³ Monotonicity and No-Missing-Codes guaranteed in 10 bit and 8 bit modes

⁴ Based on input pad leakage current. Refer to pad electricals.

2.11 Digital to Analog (DAC) Characteristics

- The accuracy at worst case: +/- 1.5% maximum
- The settling time must be less than 100 ns
- When changing the output voltage level, the voltage glitch cannot be completely eliminated

Table 13. 5-bit DAC Characteristics

Num	C	Characteristic	Symbol	Min	Typical	Max	Unit
2	D	Supply current adder (enabled)	I_{DDAC}	—	—	20	μA
3	D	DAC reference inputs	V_{in}	V_{SSA}	—	V_{DDA}	V
5	D	DAC step size	V_{step}	$0.75 \times V_{in}/32$	$V_{in}/32$	$1.25 \times V_{in}/32$	V
6	D	DAC voltage range	V_{dacout}	$V_{in}/32$	—	V_{in}	V

2.12 High Speed Comparator (HSCMP) Characteristics

Table 14. High Speed Comparator Electrical Specifications

Num	C	Characteristic ¹	Symbol	Min	Typical	Max	Unit
1	D	Supply current, High Speed Mode (EN=1, PMODE=1)	I_{DDAHS}	—	200		μA
2	D	Supply current, Low Speed Mode (EN=1, PMODE=0)	I_{DDALS}	—	10		μA
3	—	Analog input voltage	V_{AIN}	V_{SSA}	—	V_{DDA}	V
4	P	Analog input offset voltage	V_{AIO}	—	5	40	mV
5	C	Analog Comparator hysteresis	V_H	3.0	9	20.0	mV
6	T	Propagation Delay, High Speed Mode (EN=1, PMODE=1)	t_{DHS}^2	—	70	120	ns
7	T	Propagation Delay, Low Speed Mode (EN=1, PMODE=0)	t_{DLS}^2	—	400	600	ns
8	D	Analog comparator initialization delay	t_{AINIT}	—	400	—	ns

¹ All timing assumes slew rate control disabled and high drive strength enabled.

² Delay from analog input to the CMPxOUT output pin. Measured with an input waveform that switches 30 mV above and below the reference.

2.13 Programmable Gain Amplifier (PGA) Characteristics

Table 15. Programmable Gain Amplifier Electrical Specifications

Num	C	Parameter	Symbol	Min	Typical	Max	Unit
1	T	Supply current adder • normal mode (LP=0) • low power mode (LP=1)	I_{DDON}	— —	450 250	550 300	μA
2	T	Supply current adder (stand-by)	I_{DDAOFF}	—	1	10	nA
3	T	Absolute analog input level	V_{IL}	V_{SSA}	$V_{DDA}/2$	V_{DDA}	V

Table 15. Programmable Gain Amplifier Electrical Specifications (continued)

Num	C	Parameter	Symbol	Min	Typical	Max	Unit
4	D	Differential input voltage	$V_{DIFFMAX}$	$-\left(\frac{V_{DDA}-1.4}{2 \times Gain}\right)$	0	$\frac{V_{DDA}-1.4}{2 \times Gain}$	V
5	T	Linearity (@ voltage gain) ¹ <ul style="list-style-type: none"> • 1x • 2x • 4x • 8x • 16x • 32x 	L_V	1 – 1/2 LSB 2 – 1/2 LSB 4 – 1 LSB 8 – 1 LSB 16 – 4 LSB 32 – 4 LSB	1 2 4 8 16 32	1 + 1/2 LSB 2 + 1/2 LSB 4 + 1 LSB 8 + 1 LSB 16 + 4 LSB 32 + 4 LSB	V/V
6	T	Max gain error	E_G	—	1	2	%
7a	D	PGA clock <ul style="list-style-type: none"> • normal mode (LP=0) • low power mode (LP=1) 	f_{PGA}	— —	8 ² 4	8 ² 4	MHz
7b	D	PGA sampling frequency ³	f_{SAMPL}	—	$\frac{1}{\left(\frac{12 + 18 \times NUM_CLK_GS}{f_{PGA}}\right) + \frac{43}{f_{ADC}} + \frac{5}{f_{BUS}}}$	—	Samples per second
8	D	Input signal bandwidth	BW	0	$f_{SAMPL} \div 8$	$f_{SAMPL} \div 2$	Hz
9	D	Charge pump clock frequency	f_{cpclk}	100	$f_{PGA} \div 4$	—	Hz

¹ LSB in 12-bit resolution

² 8 MHz is required for PGA achieving 1 μs sampling time.

³ ADC in 12-bit mode, long sampling time, $f_{ADC} = f_{PGA}$

2.14 AC Characteristics

This section describes timing characteristics for each peripheral system.

2.14.1 Control Timing

Table 16. Control Timing

Num	C	Rating	Symbol	Min	Typ ¹	Max	Unit	
1	D	Bus frequency ($t_{cyc} = 1/f_{Bus}$)	–40 to 105 °C	f_{Bus}	DC	—	25.67	MHz
			–40 to 125 °C	f_{Bus}	DC	—	20	MHz
2	P	Internal low power oscillator period	t_{LPO}	700	—	1300	μs	
3	D	External reset pulse width ²	t_{extrst}	100	—	—	ns	
4	D	Reset low drive	t_{rstdrv}	$34 \times t_{cyc}$	—	—	ns	
5	D	BKGD/MS setup time after issuing background debug force reset to enter user or BDM modes	t_{MSSU}	500	—	—	ns	
6	D	BKGD/MS hold time after issuing background debug force reset to enter user or BDM modes ³	t_{MSH}	100	—	—	μs	

Table 16. Control Timing (continued)

Num	C	Rating	Symbol	Min	Typ ¹	Max	Unit
7	D	Keyboard interrupt pulse width Asynchronous path ⁴ Synchronous path ⁵	t_{LIH}, t_{HIL}	100 $1.5 \times t_{cyc}$	— —	— —	ns
8	C	Port rise and fall time — Low output drive (PTxDS = 0) (load = 50 pF) ⁶ Slew rate control disabled (PTxSE = 0) Slew rate control enabled (PTxSE = 1)	t_{Rise}, t_{Fall}	— —	40 75	— —	ns
		Port rise and fall time — High output drive (PTxDS = 1) (load = 50 pF) ⁶ Slew rate control disabled (PTxSE = 0) Slew rate control enabled (PTxSE = 1)	t_{Rise}, t_{Fall}	— —	11 35	— —	ns

- ¹ Typical values are based on characterization data at $V_{DD} = 5.0V$, $25^{\circ}C$ unless otherwise stated.
- ² This is the shortest pulse that is guaranteed to be recognized as a reset pin request.
- ³ To enter BDM mode following a POR, BKGD/MS should be held low during the power-up and for a hold time of t_{MSH} after V_{DD} rises above V_{LVD} .
- ⁴ This is the minimum pulse width that is guaranteed to be recognized as a keyboard interrupt request in stop mode.
- ⁵ This is the minimum pulse width that is guaranteed to pass through the pin synchronization circuitry. Shorter pulses may or may not be recognized. In stop mode, the synchronizer is bypassed so shorter pulses can be recognized in that case.
- ⁶ Timing is shown with respect to 20% V_{DD} and 80% V_{DD} levels. Temperature range $-40^{\circ}C$ to $125^{\circ}C$.

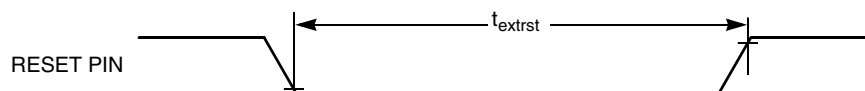

Figure 17. Reset Timing

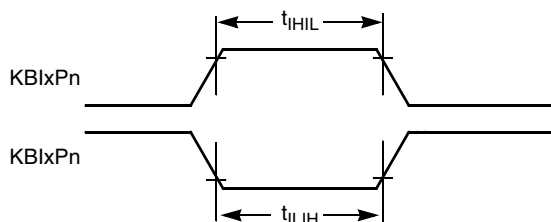

Figure 18. KBlxPn Timing

2.14.2 FTM Module Timing

Synchronizer circuits determine the shortest input pulses that can be recognized or the fastest clock that can be used as the optional external source to the FTM timer counter. These synchronizers operate from the current ICSOUT clock. The ICSOUT clock period = $0.5 \times t_{cyc} = 1/(f_{Bus} \times 2)$.

Table 17. FTM Input Timing

No.	C	Function	Symbol	Min	Max	Unit
1	D	External clock frequency	f_{TCLK}	0	$f_{ICSOUT}/4^1$	Hz
2	D	External clock period	t_{TCLK}	2	—	t_{cyc}
3	D	External clock high time	t_{clkh}	0.75	—	t_{cyc}

Table 17. FTM Input Timing (continued)

No.	C	Function	Symbol	Min	Max	Unit
4	D	External clock low time	t_{ckl}	0.75	—	t_{cyc}
5	D	Input capture pulse width	t_{ICPW}	0.75	—	t_{cyc}

¹ The maximum external clock frequency is limited to 10MHz due to input filter characteristics.

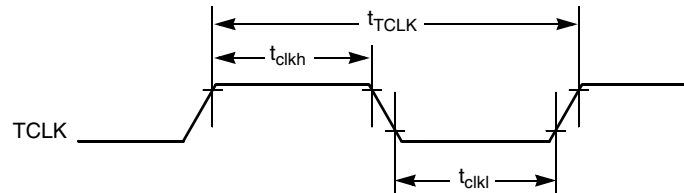

Figure 19. FTM External Clock

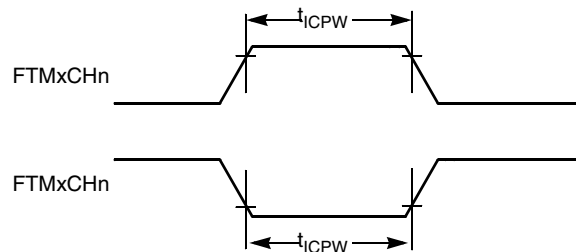

Figure 20. FTM Input Capture Pulse

2.14.3 MTIM Module Timing

Synchronizer circuits determine the fastest clock that can be used as the optional external clock source to the MTIM timer counter. These synchronizers operate from the current bus rate clock.

Table 18. MTIM Input Timing

No.	C	Function	Symbol	Min	Max	Unit
1	D	External clock frequency	f_{TCLK}	0	$f_{\text{Bus}}/4$	Hz
2	D	External clock period	t_{TCLK}	4	—	t_{cyc}
3	D	External clock high time	t_{clkh}	1.5	—	t_{cyc}
4	D	External clock low time	t_{ckl}	1.5	—	t_{cyc}

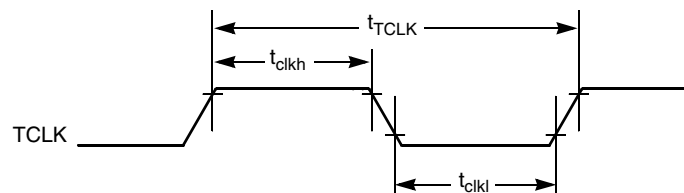

Figure 21. MTIM Timer External Clock

2.14.4 SPI

Table 19 and Figure 22 through Figure 25 describe the timing requirements for the SPI system.

Table 19. SPI Electrical Characteristics

Num ¹	C	Rating ²	Symbol	Min	Max	Unit
1	D	Cycle time Master Slave	t_{SCK}	2	4096	t_{cyc}
			t_{SCK}	4	—	t_{cyc}
2	D	Enable lead time Master Slave	t_{Lead}	—	1/2	t_{SCK}
			t_{Lead}	1/2	—	t_{SCK}
3	D	Enable lag time Master Slave	t_{Lag}	—	1/2	t_{SCK}
			t_{Lag}	1/2	—	t_{SCK}
4	D	Clock (SPSCK) high time Master and Slave	t_{SCKH}	$1/2 t_{SCK} - 25$	—	ns
5	D	Clock (SPSCK) low time Master and Slave	t_{SCKL}	$1/2 t_{SCK} - 25$	—	ns
6	D	Data setup time (inputs) Master Slave	$t_{SI(M)}$	30	—	ns
			$t_{SI(S)}$	30	—	ns
7	D	Data hold time (inputs) Master Slave	$t_{HI(M)}$	30	—	ns
			$t_{HI(S)}$	30	—	ns
8	D	Access time, slave ³	t_A	0	40	ns
9	D	Disable time, slave ⁴	t_{dis}	—	40	ns
10	D	Data setup time (outputs) Master Slave	t_{SO}	—	25	ns
			t_{SO}	—	25	ns
11	D	Data hold time (outputs) Master Slave	t_{HO}	-10	—	ns
			t_{HO}	-10	—	ns
12	D	Operating frequency Master (SPIFE=0) Slave (SPIFE=0) Master (SPIFE=1) Slave (SPIFE=1)	f_{op}	$f_{Bus}/4096$	8^5	MHz
				dc	$f_{Bus}/4$	
				$f_{Bus}/4096$	5^6	MHz
				dc	5^6	

¹ Refer to Figure 22 through Figure 25.

² All timing is shown with respect to 20% V_{DD} and 70% V_{DD} , unless noted; 100 pF load on all SPI pins. All timing assumes slew rate control disabled and high drive strength enabled for SPI output pins.

³ Time to data active from high-impedance state.

⁴ Hold time to high-impedance state.

⁵ Maximum baud rate must be limited to 8 MHz.

⁶ Maximum baud rate must be limited to 5 MHz due to input filter characteristics.

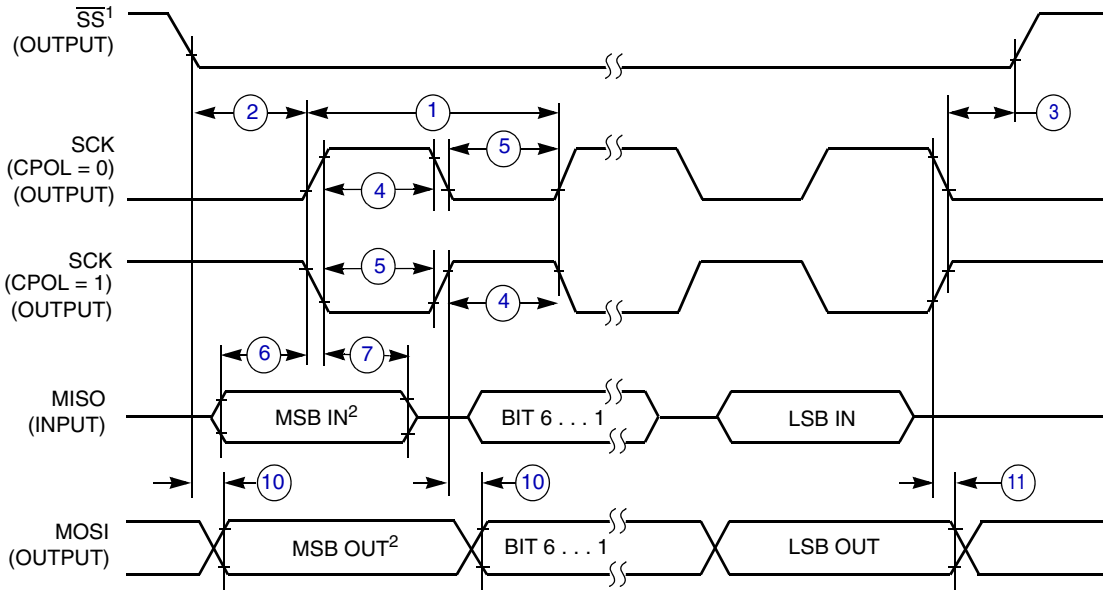

NOTES:

1. \overline{SS} output mode (MODFEN = 1, SSOE = 1).
2. LSBF = 0. For LSBF = 1, bit order is LSB, bit 1, ..., bit 6, MSB.

Figure 22. SPI Master Timing (CPHA = 0)

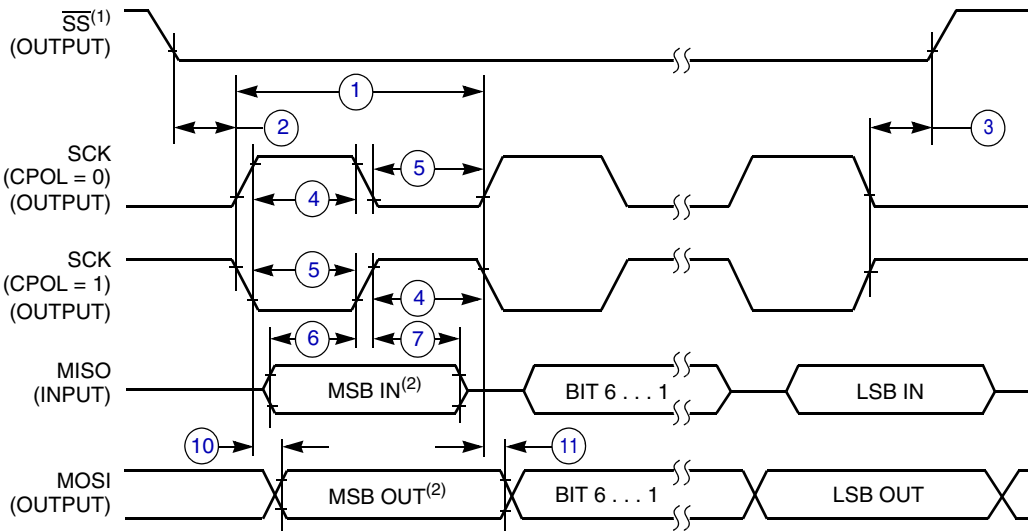

NOTES:

1. \overline{SS} output mode (MODFEN = 1, SSOE = 1).
2. LSBF = 0. For LSBF = 1, bit order is LSB, bit 1, ..., bit 6, MSB.

Figure 23. SPI Master Timing (CPHA = 1)

Electrical Characteristics

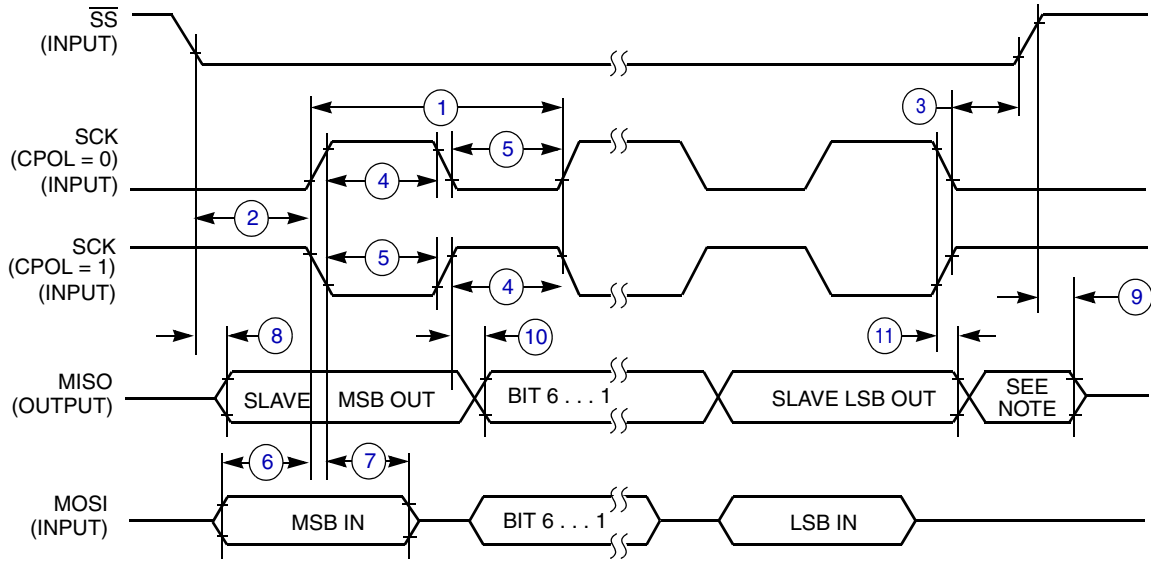

NOTE:

1. Not defined but normally MSB of character just received

Figure 24. SPI Slave Timing (CPHA = 0)

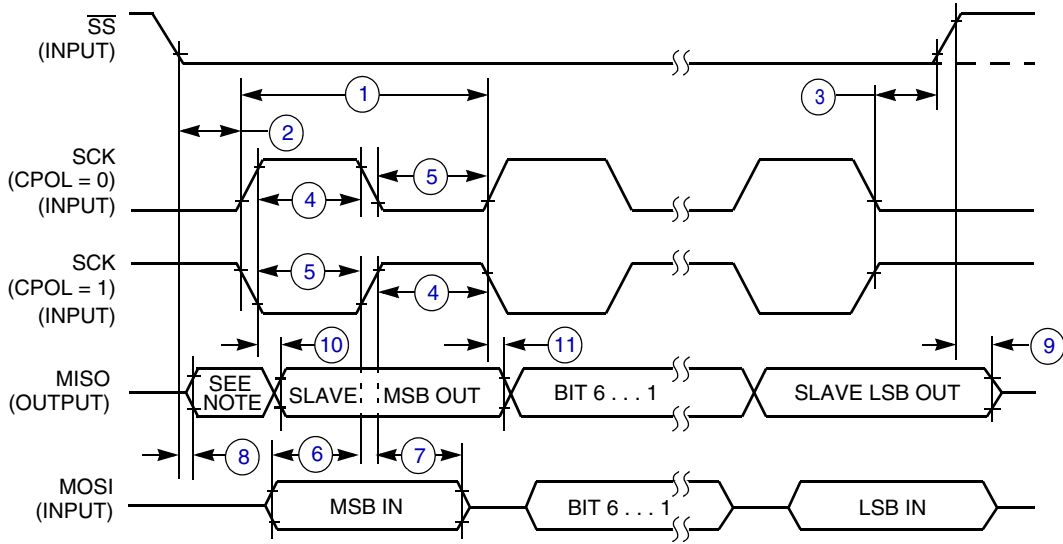

NOTE:

1. Not defined but normally LSB of character just received

Figure 25. SPI Slave Timing (CPHA = 1)

2.15 Flash Memory Specifications

This section provides details about program/erase times and program-erase endurance for the flash memory.

Program and erase operations do not require any special power sources other than the normal V_{DD} supply. For more detailed information about program/erase operations, see the Memory section.

Table 20. Flash Memory Characteristics

Num	C	Characteristic	Symbol	Min	Typical	Max	Unit
1	—	Supply voltage for program/erase -40°C to 125°C	$V_{\text{prog/erase}}$	2.7		5.5	V
2	—	Supply voltage for read operation	V_{Read}	2.7		5.5	V
3	—	Internal FCLK frequency ¹	f_{FCLK}	150		200	kHz
4	—	Internal FCLK period (1/FCLK)	t_{Fcyc}	5		6.67	μs
5	C	Byte program time (random location) ²	t_{prog}	9			t_{Fcyc}
6	—	Byte program time (burst mode) ²	t_{Burst}	4			t_{Fcyc}
7	D	Page erase time ²	t_{Page}	4000			t_{Fcyc}
8	D	Mass erase time ²	t_{Mass}	20,000			t_{Fcyc}
9	C	Byte program current ³	R_{IDDBP}	—	4	—	mA
10	C	Page erase current ³	R_{IDDPE}	—	6	—	mA
11	C	Program/erase endurance ⁴ T_L to $T_H = -40^\circ\text{C}$ to $+125^\circ\text{C}$ $T = 25^\circ\text{C}$		10,000	— 100,000	— —	cycles
12	C	Data retention ⁵	$t_{\text{D_ret}}$	15	100	—	years

¹ The frequency of this clock is controlled by a software setting.

² These values are hardware state machine controlled. User code does not need to count cycles. This information supplied for calculating approximate time to program and erase.

³ The program and erase currents are additional to the standard run I_{DD} . These values are measured at room temperatures with $V_{DD} = 5.0$ V, bus frequency = 4.0 MHz.

⁴ **Typical endurance for Flash** is based upon the intrinsic bit cell performance. For additional information on how Freescale defines typical endurance, please refer to Engineering Bulletin EB619/D, *Typical Endurance for Nonvolatile Memory*.

⁵ **Typical data retention** values are based on intrinsic capability of the technology measured at high temperature and de-rated to 25°C using the Arrhenius equation. For additional information on how Freescale defines typical data retention, please refer to Engineering Bulletin EB618/D, *Typical Data Retention for Nonvolatile Memory*.

2.16 EMC Performance

Electromagnetic compatibility (EMC) performance is highly dependant on the environment in which the MCU resides. Board design and layout, circuit topology choices, location and characteristics of external components as well as MCU software operation all play a significant role in EMC performance. The system designer should consult Freescale applications notes such as AN2321, AN1050, AN1263, AN2764, and AN1259 for advice and guidance specifically targeted at optimizing EMC performance.

2.16.1 Radiated Emissions

Microcontroller radiated RF emissions are measured from 150 kHz to 1 GHz using the TEM/GTEM Cell method in accordance with the IEC 61967-2 and SAE J1752/3 standards. The measurement is performed with the microcontroller installed on a

Ordering Information

custom EMC evaluation board while running specialized EMC test software. The radiated emissions from the microcontroller are measured in a TEM cell in two package orientations (North and East).

The maximum radiated RF emissions of the tested configuration in all orientations are less than or equal to the reported emissions levels.

Table 21. Radiated Emissions, Electric Field

Parameter	Symbol	Conditions	Frequency	f_{osc}/f_{BUS}	Level ¹ (Max)	Unit	
Radiated emissions, electric field	V_{RE_TEM}	$V_{DD} = 5V$ $TA = +25^{\circ}C$ package type 48 LQFP	0.15 – 50 MHz	4 MHz crystal 2 MHz bus	3	dB μ V	
			50 – 150 MHz		8		
			150 – 500 MHz		-4		
			500 – 1000 MHz		-8		
					IEC Level ²	N	—
					SAE Level ³	1	—

¹ Data based on qualification test results. The reported emission level is the value of the maximum emission, rounded up to the next whole number, from among the measured orientations in each frequency range.

² IEC level maximums: N \leq 12 dB μ V, L \leq 24 dB μ V, I \leq 36 dB μ V

³ SAE level maximums: 1 \leq 10 dB μ V, 2 \leq 20 dB μ V, 3 \leq 30 dB μ V, 4 \leq 40 dB μ V

3 Ordering Information

This section contains ordering information for MC9S08MP16 and MC9S08MP12 devices.

Table 22. Device and Package Options

Device Number ¹	Temp Range	Memory		Available Packages ²		
		Flash	RAM	48-Pin	32-Pin	28-Pin
Consumer and Industrial Qualification						
MC9S08MP16	V	16K	1024	48 LQFP	32 LQFP	28 SOIC
MC9S08MP12	V	12K	512	—	—	28 SOIC
Automotive Qualification						
S9S08MP16	C, V, M	16K	1024	48 LQFP	—	—

¹ See the *MC9S08MP16RM Reference Manual* (MC9S08MP16RM) for a complete description of modules included on each device.

² See [Table 23](#) for package information.

3.1 Device Numbering Scheme

Example of the device numbering system:

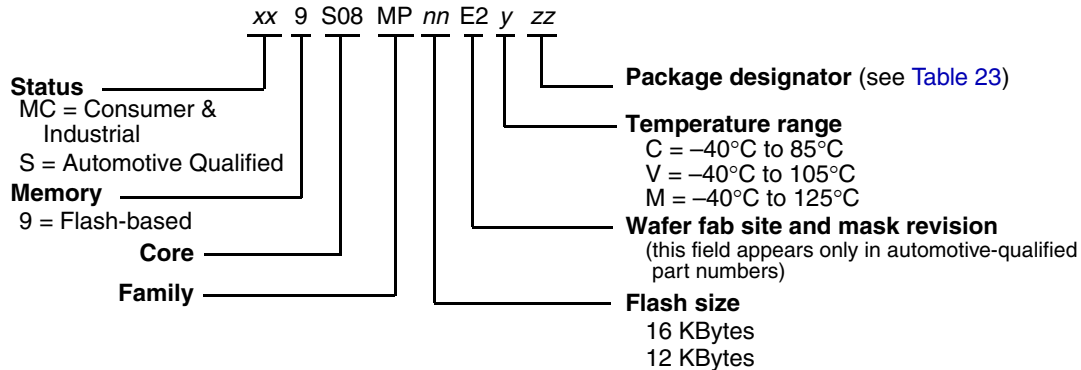

4 Package Information

The latest package outline drawings are available on the product summary pages on our web site: <http://www.freescale.com/8bit>. The following table lists the document numbers per package. Use these numbers in the web page's keyword search engine to find the latest package outline drawings.

NOTE

The 32 LQFP and 28 SOIC are not qualified to meet automotive requirements.

Table 23. Package Descriptions

Pin Count	Package Type	Abbreviation	Designator	Case No.	Document No.
48	Low Quad Flat Pack	LQFP	LF	932-03	98ASH00962A
32	Low Quad Flat Pack	LQFP	LC	873A-03	98ASH70029A
28	Small Outline Integrated Circuit	SOIC	WL	751F-05	98ASB42345B

5 Related Documentation

Find the most current versions of all documents at <http://www.freescale.com>.

Reference Manual (MC9S08MP16RM)

Contains extensive product information including modes of operation, memory, resets and interrupts, register definition, port pins, CPU, and all module information.

6 Revision History

To provide the most up-to-date information, the revision of our documents on the World Wide Web are the most current. Your printed copy may be an earlier revision. To verify you have the latest information available, refer to:

<http://www.freescale.com>

Table 24 summarizes changes contained in this document.

Table 24. Revision History

Rev	Date	Description of Changes
1	10/15/2009	Initial public revision
2	08/09/2011	Updated Table 10. Changed the value of row 8 column "C" from to C to P.

How to Reach Us:

Home Page:
www.freescale.com

Web Support:
<http://www.freescale.com/support>

USA/Europe or Locations Not Listed:
 Freescale Semiconductor, Inc.
 Technical Information Center, EL516
 2100 East Elliot Road
 Tempe, Arizona 85284
 +1-800-521-6274 or +1-480-768-2130
www.freescale.com/support

Europe, Middle East, and Africa:
 Freescale Halbleiter Deutschland GmbH
 Technical Information Center
 Schatzbogen 7
 81829 Muenchen, Germany
 +44 1296 380 456 (English)
 +46 8 52200080 (English)
 +49 89 92103 559 (German)
 +33 1 69 35 48 48 (French)
www.freescale.com/support

Japan:
 Freescale Semiconductor Japan Ltd.
 Headquarters
 ARCO Tower 15F
 1-8-1, Shimo-Meguro, Meguro-ku,
 Tokyo 153-0064
 Japan
 0120 191014 or +81 3 5437 9125
support.japan@freescale.com

Asia/Pacific:
 Freescale Semiconductor China Ltd.
 Exchange Building 23F
 No. 118 Jianguo Road
 Chaoyang District
 Beijing 100022
 China
 +86 10 5879 8000
support.asia@freescale.com

For Literature Requests Only:
 Freescale Semiconductor Literature Distribution Center
 1-800-441-2447 or 303-675-2140
 Fax: 303-675-2150
LDCForFreescaleSemiconductor@hibbertgroup.com

Document Number: MC9S08MP16
 Rev. 2
 08/2011

Information in this document is provided solely to enable system and software implementers to use Freescale Semiconductor products. There are no express or implied copyright licenses granted hereunder to design or fabricate any integrated circuits or integrated circuits based on the information in this document.

Freescale Semiconductor reserves the right to make changes without further notice to any products herein. Freescale Semiconductor makes no warranty, representation or guarantee regarding the suitability of its products for any particular purpose, nor does Freescale Semiconductor assume any liability arising out of the application or use of any product or circuit, and specifically disclaims any and all liability, including without limitation consequential or incidental damages. "Typical" parameters that may be provided in Freescale Semiconductor data sheets and/or specifications can and do vary in different applications and actual performance may vary over time. All operating parameters, including "Typicals", must be validated for each customer application by customer's technical experts. Freescale Semiconductor does not convey any license under its patent rights nor the rights of others. Freescale Semiconductor products are not designed, intended, or authorized for use as components in systems intended for surgical implant into the body, or other applications intended to support or sustain life, or for any other application in which the failure of the Freescale Semiconductor product could create a situation where personal injury or death may occur. Should Buyer purchase or use Freescale Semiconductor products for any such unintended or unauthorized application, Buyer shall indemnify and hold Freescale Semiconductor and its officers, employees, subsidiaries, affiliates, and distributors harmless against all claims, costs, damages, and expenses, and reasonable attorney fees arising out of, directly or indirectly, any claim of personal injury or death associated with such unintended or unauthorized use, even if such claim alleges that Freescale Semiconductor was negligent regarding the design or manufacture of the part.



RoHS-compliant and/or Pb-free versions of Freescale products have the functionality and electrical characteristics as their non-RoHS-compliant and/or non-Pb-free counterparts. For further information, see <http://www.freescale.com> or contact your Freescale sales representative.

For information on Freescale's Environmental Products program, go to <http://www.freescale.com/epp>.

Freescale™ and the Freescale logo are trademarks of Freescale Semiconductor, Inc. All other product or service names are the property of their respective owners.
 © Freescale Semiconductor, Inc. 2009-2011. All rights reserved.

Looking for pricing, stock, or lifecycle information?

Click below to explore more details on WIN SOURCE:

-  [View MC9S08MP16VLC on WIN SOURCE](#)
-  [Freescale Semiconductor - NXP Information](#)

Optimize Your Supply Chain with WIN SOURCE Solutions

-  Global Sourcing Solution
-  Obsolete Management
-  Cost Control Management
-  Shortage Management
-  Alternative Solution
-  Excess Inventory Management