



**THE DATASHEET OF
MC74VHC4053DTR2G**



MC74VHC4051, MC74VHC4052, MC74VHC4053

Analog Multiplexers / Demultiplexers High-Performance Silicon-Gate CMOS

The MC74VHC4051, MC74VHC4052 and MC74VHC4053 utilize silicon-gate CMOS technology to achieve fast propagation delays, low ON resistances, and low OFF leakage currents. These analog multiplexers/demultiplexers control analog voltages that may vary across the complete power supply range (from V_{CC} to V_{EE}).

The VHC4051, VHC4052 and VHC4053 are identical in pinout to the high-speed HC4051A, HC4052A and HC4053A, and the metal-gate MC14051B, MC14052B and MC14053B. The Channel-Select inputs determine which one of the Analog Inputs/Outputs is to be connected, by means of an analog switch, to the Common Output/Input. When the Enable pin is HIGH, all analog switches are turned off.

The Channel-Select and Enable inputs are compatible with standard CMOS outputs; with pullup resistors they are compatible with LSTTL outputs.

These devices have been designed so that the ON resistance (R_{on}) is more linear over input voltage than R_{on} of metal-gate CMOS analog switches.

- Fast Switching and Propagation Speeds
- Low Crosstalk Between Switches
- Diode Protection on All Inputs/Outputs
- Analog Power Supply Range ($V_{CC} - V_{EE}$) = 2.0 to 12.0 V
- Digital (Control) Power Supply Range ($V_{CC} - GND$) = 2.0 to 6.0 V
- Improved Linearity and Lower ON Resistance Than Metal-Gate Counterparts
- Low Noise
- Chip Complexity: VHC4051 — 184 FETs or 46 Equivalent Gates
VHC4052 — 168 FETs or 42 Equivalent Gates
VHC4053 — 156 FETs or 39 Equivalent Gates
- These Devices are Pb-Free and are RoHS Compliant



ON Semiconductor

<http://onsemi.com>

MARKING DIAGRAMS

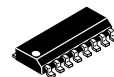

SOIC-16
D SUFFIX
CASE 751B

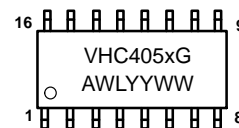

TSSOP-16
DT SUFFIX
CASE 948F

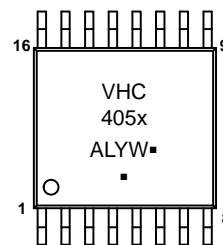

VHC405x = Specific Device Code
(x = 1, 2 or 3)

A = Assembly Location

L, WL = Wafer Lot

Y, YY = Year

W, WW = Work Week

G or ■ = Pb-Free Package

(Note: Microdot may be in either location)

ORDERING INFORMATION

See detailed ordering and shipping information in the package dimensions section on page 14 of this data sheet.

MC74VHC4051, MC74VHC4052, MC74VHC4053

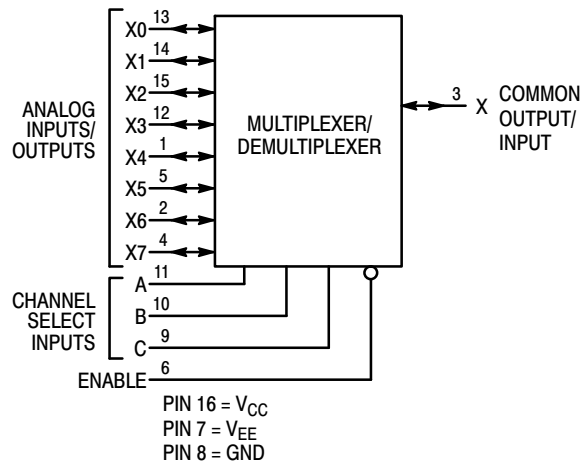

MC74VHC4051

Single-Pole, 8-Position Plus Common Off

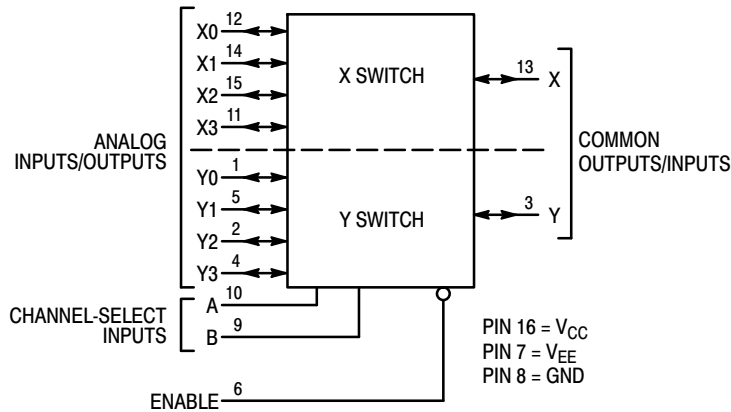

MC74VHC4052

Double-Pole, 4-Position Plus Common Off

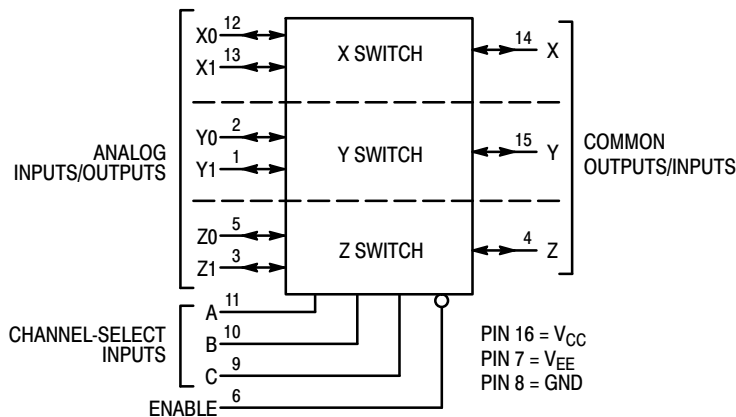

NOTE: This device allows independent control of each switch. Channel-Select Input A controls the X-Switch, Input B controls the Y-Switch and Input C controls the Z-Switch

MC74VHC4053

Triple Single-Pole, Double-Position Plus Common Off

Figure 1. Logic Diagrams

MC74VHC4051, MC74VHC4052, MC74VHC4053

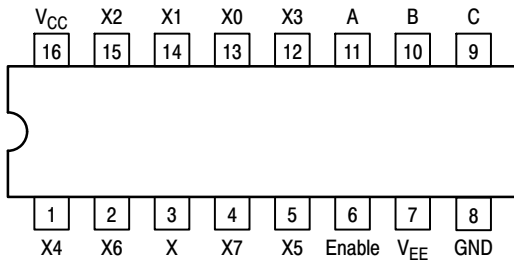

Figure 2. Pinout: MC74VHC4051 (Top View)

FUNCTION TABLE – MC74VHC4051

Control Inputs				ON Channels
Enable	Select			
	C	B	A	
L	L	L	L	X0
L	L	L	H	X1
L	L	H	L	X2
L	L	H	H	X3
L	H	L	L	X4
L	H	L	H	X5
L	H	H	L	X6
L	H	H	H	X7
H	X	X	X	NONE

X = Don't Care

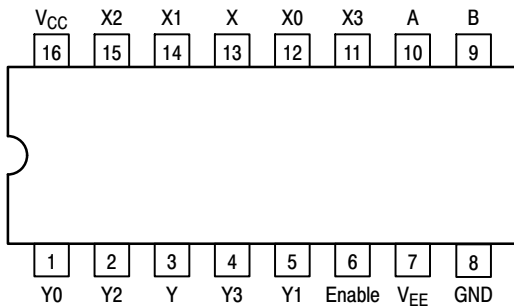

Figure 3. Pinout: MC74VHC4052 (Top View)

FUNCTION TABLE – MC74VHC4052

Control Inputs			ON Channels	
Enable	Select			
	B	A		
L	L	L	Y0	X0
L	L	H	Y1	X1
L	H	L	Y2	X2
L	H	H	Y3	X3
H	X	X	NONE	

X = Don't Care

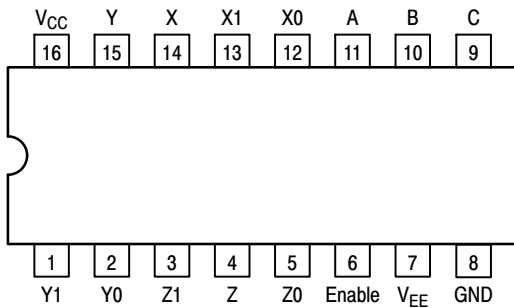

Figure 4. Pinout: MC74VHC4053 (Top View)

FUNCTION TABLE – MC74VHC4053

Control Inputs				ON Channels		
Enable	Select					
	C	B	A			
L	L	L	L	Z0	Y0	X0
L	L	L	H	Z0	Y0	X1
L	L	H	L	Z0	Y1	X0
L	L	H	H	Z0	Y1	X1
L	H	L	L	Z1	Y0	X0
L	H	L	H	Z1	Y0	X1
L	H	H	L	Z1	Y1	X0
L	H	H	H	Z1	Y1	X1
H	X	X	X	NONE		

X = Don't Care

MC74VHC4051, MC74VHC4052, MC74VHC4053

MAXIMUM RATINGS

Symbol	Parameter	Value	Unit
V_{CC}	Positive DC Supply Voltage (Referenced to GND) (Referenced to V_{EE})	- 0.5 to + 7.0 - 0.5 to + 14.0	V
V_{EE}	Negative DC Supply Voltage (Referenced to GND)	- 7.0 to + 5.0	V
V_{IS}	Analog Input Voltage	$V_{EE} - 0.5$ to $V_{CC} + 0.5$	V
V_{in}	Digital Input Voltage (Referenced to GND)	- 0.5 to $V_{CC} + 0.5$	V
I	DC Current, Into or Out of Any Pin	± 25	mA
P_D	Power Dissipation in Still Air SOIC Package† TSSOP Package†	500 450	mW
T_{stg}	Storage Temperature Range	- 65 to + 150	°C
T_L	Lead Temperature, 1 mm from Case for 10 Seconds	260	°C

This device contains protection circuitry to guard against damage due to high static voltages or electric fields. However, precautions must be taken to avoid applications of any voltage higher than maximum rated voltages to this high-impedance circuit. For proper operation, V_{in} and V_{out} should be constrained to the range $GND \leq (V_{in} \text{ or } V_{out}) \leq V_{CC}$. Unused inputs must always be tied to an appropriate logic voltage level (e.g., either GND or V_{CC}). Unused outputs must be left open.

Stresses exceeding those listed in the Maximum Ratings table may damage the device. If any of these limits are exceeded, device functionality should not be assumed, damage may occur and reliability may be affected.

†Derating — SOIC Package: - 7 mW/°C from 65° to 125°C
TSSOP Package: - 6.1 mW/°C from 65° to 125°C

RECOMMENDED OPERATING CONDITIONS

Symbol	Parameter	Min	Max	Unit
V_{CC}	Positive DC Supply Voltage (Referenced to GND) (Referenced to V_{EE})	2.0 2.0	6.0 12.0	V
V_{EE}	Negative DC Supply Voltage, Output (Referenced to GND)	- 6.0	GND	V
V_{IS}	Analog Input Voltage	V_{EE}	V_{CC}	V
V_{in}	Digital Input Voltage (Referenced to GND)	GND	V_{CC}	V
V_{IO}^*	Static or Dynamic Voltage Across Switch		1.2	V
T_A	Operating Temperature Range, All Package Types	- 55	+ 125	°C
t_r, t_f	Input Rise/Fall Time (Channel Select or Enable Inputs)	$V_{CC} = 2.0$ V $V_{CC} = 3.0$ V $V_{CC} = 4.5$ V $V_{CC} = 6.0$ V	0 1000 800 500 400	ns

Functional operation above the stresses listed in the Recommended Operating Ranges is not implied. Extended exposure to stresses beyond the Recommended Operating Ranges limits may affect device reliability.

*For voltage drops across switch greater than 1.2V (switch on), excessive V_{CC} current may be drawn; i.e., the current out of the switch may contain both V_{CC} and switch input components. The reliability of the device will be unaffected unless the Maximum Ratings are exceeded.

MC74VHC4051, MC74VHC4052, MC74VHC4053

DC CHARACTERISTICS — Digital Section (Voltages Referenced to GND) $V_{EE} = \text{GND}$, Except Where Noted

Symbol	Parameter	Condition	V_{CC} V	Guaranteed Limit			Unit
				-55 to 25°C	≤85°C	≤125°C	
V_{IH}	Minimum High-Level Input Voltage, Channel-Select or Enable Inputs	$R_{on} = \text{Per Spec}$	2.0	1.50	1.50	1.50	V
			3.0	2.10	2.10	2.10	
			4.5	3.15	3.15	3.15	
			6.0	4.20	4.20	4.20	
V_{IL}	Maximum Low-Level Input Voltage, Channel-Select or Enable Inputs	$R_{on} = \text{Per Spec}$	2.0	0.5	0.5	0.5	V
			3.0	0.9	0.9	0.9	
			4.5	1.35	1.35	1.35	
			6.0	1.8	1.8	1.8	
I_{in}	Maximum Input Leakage Current, Channel-Select or Enable Inputs	$V_{in} = V_{CC}$ or GND, $V_{EE} = -6.0 \text{ V}$	6.0	± 0.1	± 1.0	± 1.0	μA
I_{CC}	Maximum Quiescent Supply Current (per Package)	Channel Select, Enable and $V_{IS} = V_{CC}$ or GND; $V_{EE} = \text{GND}$ $V_{IO} = 0 \text{ V}$ $V_{EE} = -6.0$	6.0	1	10	40	μA
			6.0	4	40	80	

DC ELECTRICAL CHARACTERISTICS Analog Section

Symbol	Parameter	Test Conditions	V_{CC} V	V_{EE} V	Guaranteed Limit			Unit
					- 55 to 25°C	≤ 85°C	≤ 125°C	
R_{on}	Maximum "ON" Resistance	$V_{in} = V_{IL}$ or V_{IH} $V_{IS} = V_{CC}$ to V_{EE} $I_S \leq 2.0 \text{ mA}$ (Figures 5 through 11)	3.0	0.0	200	240	320	Ω
			4.5	0.0	160	200	280	
		4.5	-4.5	120	150	170		
		6.0	-6.0	100	125	140		
		$V_{in} = V_{IL}$ or V_{IH} $V_{IS} = V_{CC}$ or V_{EE} (Endpoints) $I_S \leq 2.0 \text{ mA}$ (Figures 5 through 11)	3.0	0.0	150	180	230	
			4.5	0.0	110	140	190	
ΔR_{on}	Maximum Difference in "ON" Resistance Between Any Two Channels in the Same Package	$V_{in} = V_{IL}$ or V_{IH} $V_{IS} = 1/2 (V_{CC} - V_{EE})$ $I_S \leq 2.0 \text{ mA}$	3.0	0.0	40	50	80	Ω
			4.5	0.0	20	25	40	
			4.5	-4.5	10	15	18	
			6.0	-6.0	10	12	14	
I_{off}	Maximum Off-Channel Leakage Current, Any One Channel	$V_{in} = V_{IL}$ or V_{IH} ; $V_{IO} = V_{CC} - V_{EE}$; Switch Off (Figure 12)	6.0	-6.0	0.1	0.5	1.0	μA
			Maximum Off-Channel Leakage Current, VHC4052 Common Channel VHC4053	$V_{in} = V_{IL}$ or V_{IH} ; $V_{IO} = V_{CC} - V_{EE}$; Switch Off (Figure 13)	6.0	-6.0	0.2	
	6.0	-6.0			0.1	1.0	2.0	
I_{on}	Maximum On-Channel Leakage Current, VHC4051 Channel-to-Channel VHC4053	$V_{in} = V_{IL}$ or V_{IH} ; Switch-to-Switch = $V_{CC} - V_{EE}$; (Figure 14)	6.0	-6.0	0.2	2.0	4.0	μA
			6.0	-6.0	0.1	1.0	2.0	
			6.0	-6.0	0.1	1.0	2.0	

MC74VHC4051, MC74VHC4052, MC74VHC4053

AC CHARACTERISTICS (C_L = 50 pF, Input t_r = t_f = 6 ns)

Symbol	Parameter	V _{CC} V	Guaranteed Limit			Unit
			-55 to 25°C	≤85°C	≤125°C	
t _{PLH} , t _{PHL}	Maximum Propagation Delay, Channel–Select to Analog Output (Figures 18, 19)	2.0	270	320	350	ns
		3.0	90	110	125	
		4.5	59	79	85	
		6.0	45	65	75	
t _{PLH} , t _{PHL}	Maximum Propagation Delay, Analog Input to Analog Output (Figures 20, 21)	2.0	40	60	70	ns
		3.0	25	30	32	
		4.5	12	15	18	
		6.0	10	13	15	
t _{PLZ} , t _{PHZ}	Maximum Propagation Delay, Enable to Analog Output (Figures 22, 23)	2.0	160	200	220	ns
		3.0	70	95	110	
		4.5	48	63	76	
		6.0	39	55	63	
t _{PZL} , t _{PZH}	Maximum Propagation Delay, Enable to Analog Output (Figures 22, 23)	2.0	245	315	345	ns
		3.0	115	145	155	
		4.5	49	69	83	
		6.0	39	58	67	
C _{in}	Maximum Input Capacitance, Channel–Select or Enable Inputs		10	10	10	pF
C _{I/O}	Maximum Capacitance (All Switches Off)	Analog I/O	35	35	35	pF
		Common O/I: VHC4051	130	130	130	
		VHC4052	80	80	80	
		VHC4053	50	50	50	
	Feedthrough		1.0	1.0	1.0	
C _{PD}	Power Dissipation Capacitance (Figure 25)*	Typical @ 25°C, V _{CC} = 5.0 V, V _{EE} = 0 V			pF	
		VHC4051	45			
		VHC4052	80			
		VHC4053	45			

* Used to determine the no-load dynamic power consumption: P_D = C_{PD} V_{CC}²f + I_{CC} V_{CC}.

MC74VHC4051, MC74VHC4052, MC74VHC4053

ADDITIONAL APPLICATION CHARACTERISTICS (GND = 0 V)

Symbol	Parameter	Condition	V _{CC} V	V _{EE} V	Limit*			Unit
					25°C			
BW	Maximum On-Channel Bandwidth or Minimum Frequency Response (Figure 15)	f _{in} = 1MHz Sine Wave; Adjust f _{in} Voltage to Obtain 0dBm at V _{OS} ; Increase f _{in} Frequency Until dB Meter Reads -3dB; R _L = 50Ω, C _L = 10pF	2.25	-2.25	'51	'52	'53	MHz
			4.50	-4.50	80	95	120	
			6.00	-6.00	80	95	120	
—	Off-Channel Feedthrough Isolation (Figure 16)	f _{in} = Sine Wave; Adjust f _{in} Voltage to Obtain 0dBm at V _{IS} f _{in} = 10kHz, R _L = 600Ω, C _L = 50pF	2.25	-2.25	-50			dB
			4.50	-4.50	-50			
—	Feedthrough Noise. Channel-Select Input to Common I/O (Figure 17)	V _{in} ≤ 1MHz Square Wave (t _r = t _f = 6ns); Adjust R _L at Setup so that I _S = 0A; Enable = GND R _L = 600Ω, C _L = 50pF	2.25	-2.25	25			mV _{PP}
			4.50	-4.50	105			
—	Crosstalk Between Any Two Switches (Figure 24) (Test does not apply to VHC4051)	f _{in} = Sine Wave; Adjust f _{in} Voltage to Obtain 0dBm at V _{IS} f _{in} = 10kHz, R _L = 600Ω, C _L = 50pF	2.25	-2.25	-50			dB
			4.50	-4.50	-50			
—	Crosstalk Between Any Two Switches (Figure 24) (Test does not apply to VHC4051)	f _{in} = 1.0MHz, R _L = 50Ω, C _L = 10pF	2.25	-2.25	-60			dB
			4.50	-4.50	-60			
THD	Total Harmonic Distortion (Figure 26)	f _{in} = 1kHz, R _L = 10kΩ, C _L = 50pF THD = THD _{measured} - THD _{source} V _{IS} = 4.0V _{PP} sine wave V _{IS} = 8.0V _{PP} sine wave V _{IS} = 11.0V _{PP} sine wave	2.25	-2.25	0.10			%
			4.50	-4.50	0.08			
—	Total Harmonic Distortion (Figure 26)	f _{in} = 1kHz, R _L = 10kΩ, C _L = 50pF THD = THD _{measured} - THD _{source} V _{IS} = 4.0V _{PP} sine wave V _{IS} = 8.0V _{PP} sine wave V _{IS} = 11.0V _{PP} sine wave	6.00	-6.00	0.05			%
			6.00	-6.00	0.05			

*Limits not tested. Determined by design and verified by qualification.

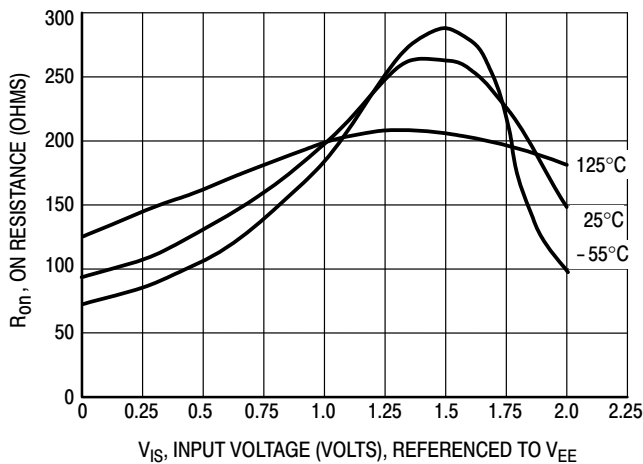

Figure 5. Typical On Resistance, V_{CC} - V_{EE} = 2.0 V

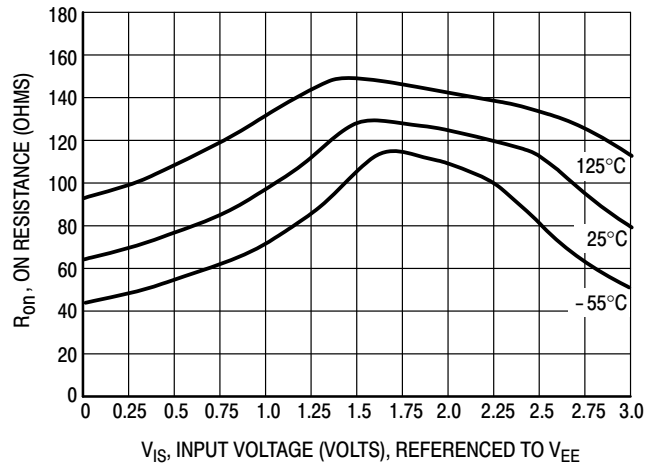

Figure 6. Typical On Resistance, V_{CC} - V_{EE} = 3.0 V

MC74VHC4051, MC74VHC4052, MC74VHC4053

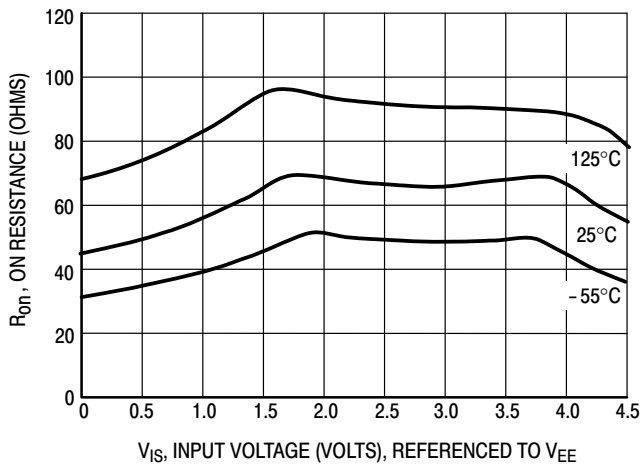

Figure 7. Typical On Resistance, $V_{CC} - V_{EE} = 4.5$ V

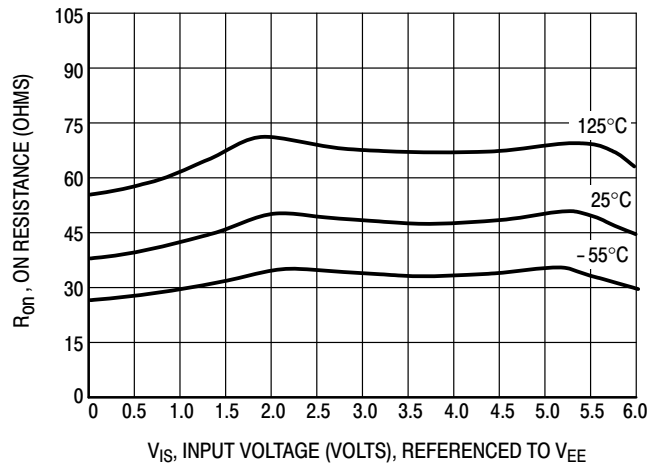

Figure 8. Typical On Resistance, $V_{CC} - V_{EE} = 6.0$ V

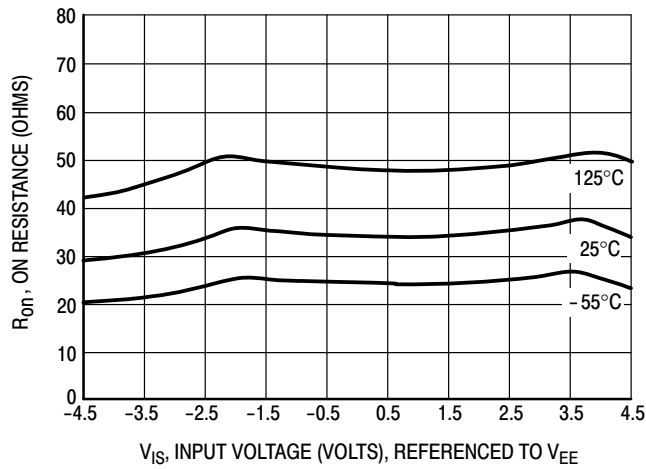

Figure 9. Typical On Resistance, $V_{CC} - V_{EE} = 9.0$ V

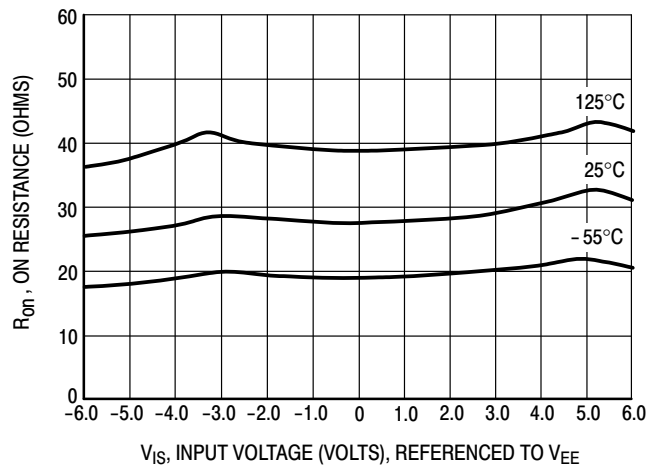

Figure 10. Typical On Resistance, $V_{CC} - V_{EE} = 12.0$ V

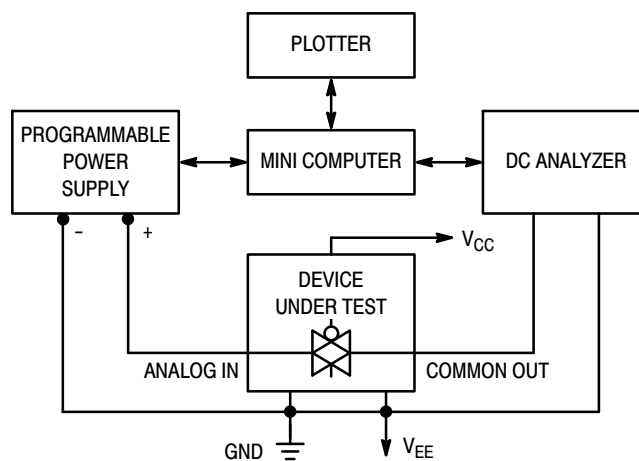

Figure 11. On Resistance Test Set-Up

MC74VHC4051, MC74VHC4052, MC74VHC4053

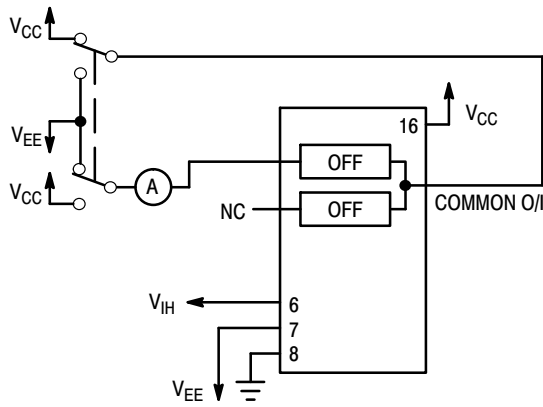

Figure 12. Maximum Off Channel Leakage Current, Any One Channel, Test Set-Up

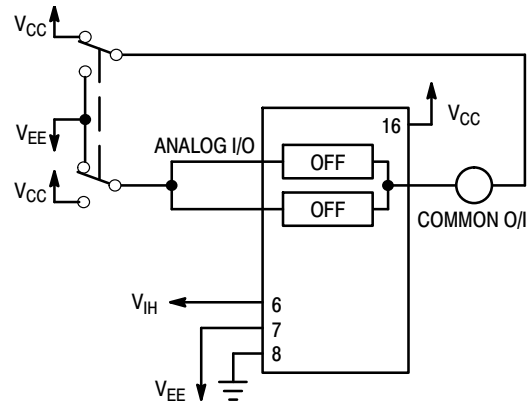

Figure 13. Maximum Off Channel Leakage Current, Common Channel, Test Set-Up

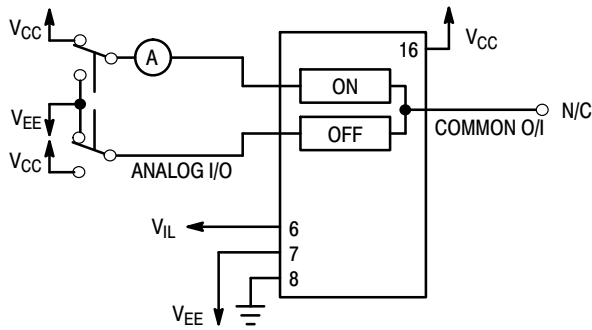
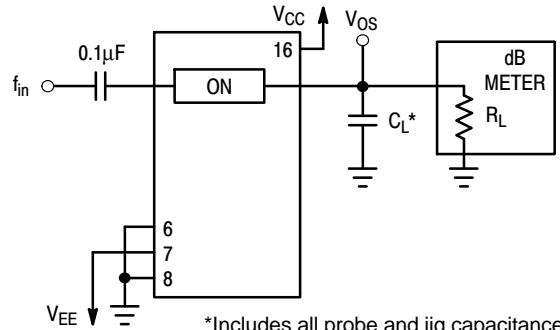
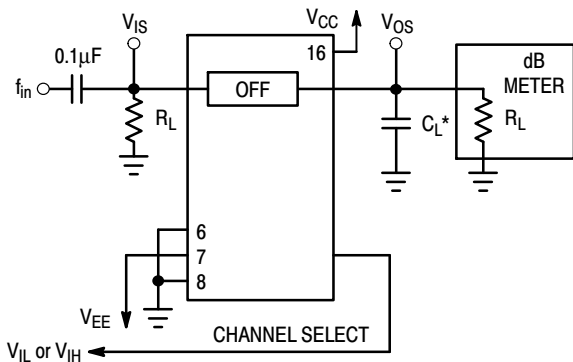

Figure 14. Maximum On Channel Leakage Current, Channel to Channel, Test Set-Up



*Includes all probe and jig capacitance

Figure 15. Maximum On Channel Bandwidth, Test Set-Up



*Includes all probe and jig capacitance

Figure 16. Off Channel Feedthrough Isolation, Test Set-Up

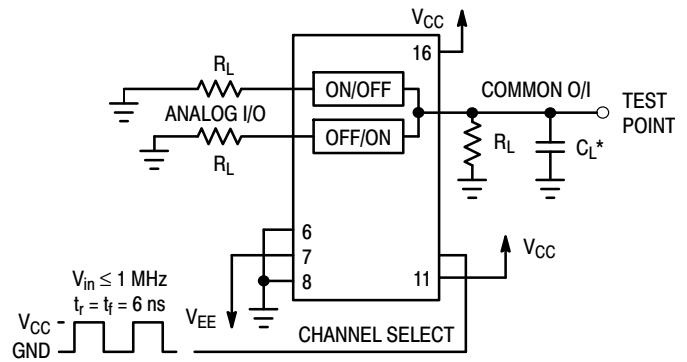

*Includes all probe and jig capacitance

Figure 17. Feedthrough Noise, Channel Select to Common Out, Test Set-Up

MC74VHC4051, MC74VHC4052, MC74VHC4053

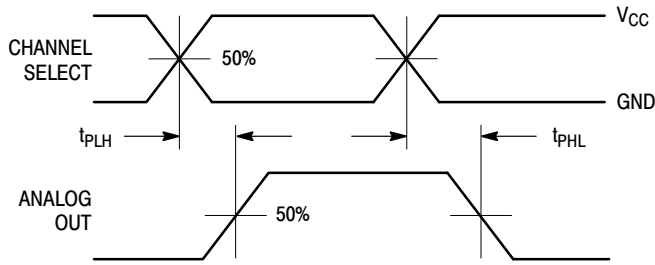
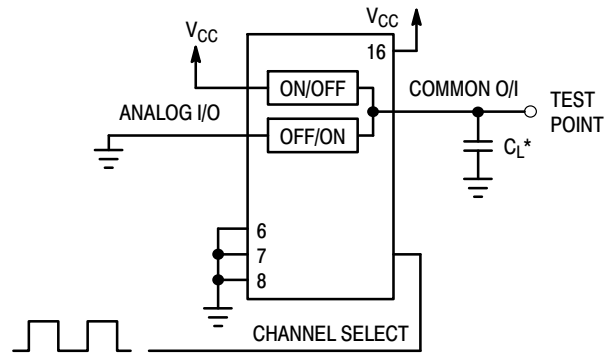

Figure 18. Propagation Delays, Channel Select to Analog Out



*Includes all probe and jig capacitance

Figure 19. Propagation Delay, Test Set-Up Channel Select to Analog Out

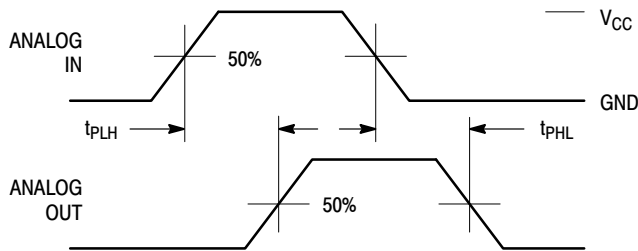
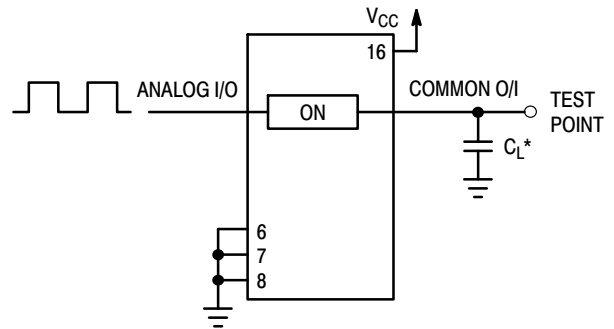

Figure 20. Propagation Delays, Analog In to Analog Out



*Includes all probe and jig capacitance

Figure 21. Propagation Delay, Test Set-Up Analog In to Analog Out

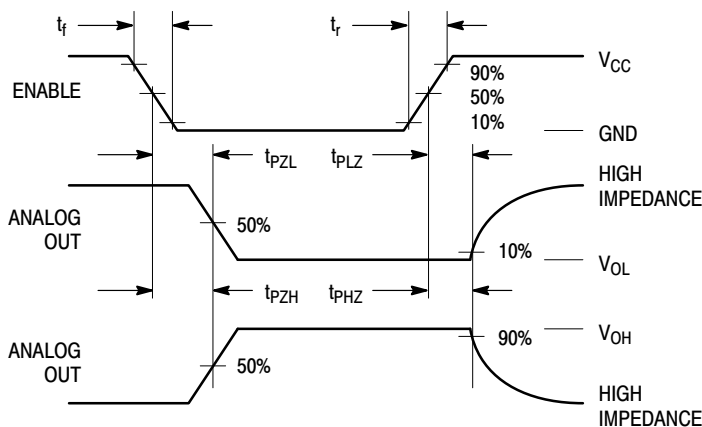

Figure 22. Propagation Delays, Enable to Analog Out

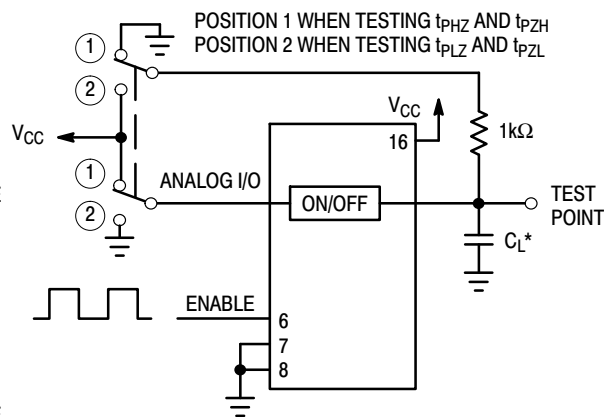
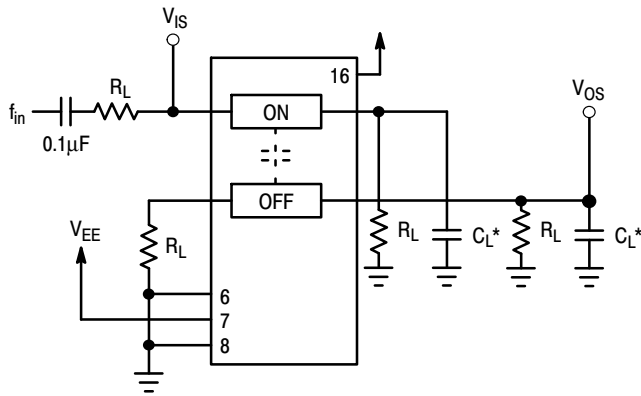

Figure 23. Propagation Delay, Test Set-Up Enable to Analog Out

MC74VHC4051, MC74VHC4052, MC74VHC4053



*Includes all probe and jig capacitance

Figure 24. Crosstalk Between Any Two Switches, Test Set-Up

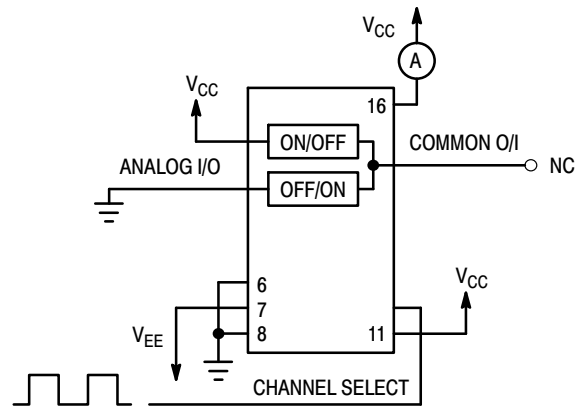
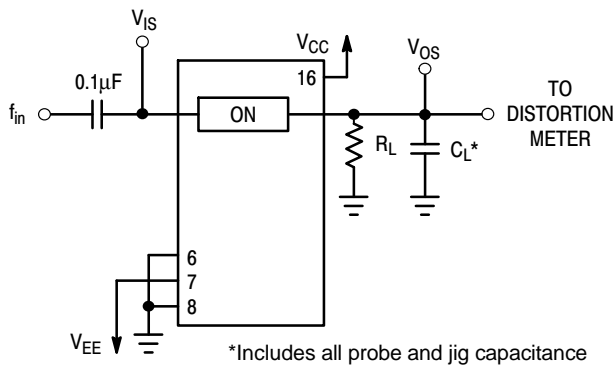

Figure 25. Power Dissipation Capacitance, Test Set-Up



*Includes all probe and jig capacitance

Figure 26. Total Harmonic Distortion, Test Set-Up

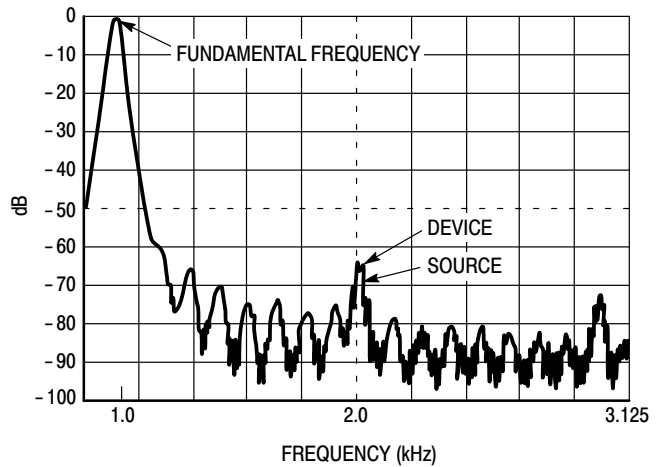

Figure 27. Plot, Harmonic Distortion

APPLICATIONS INFORMATION

The Channel Select and Enable control pins should be at V_{CC} or GND logic levels. V_{CC} being recognized as a logic high and GND being recognized as a logic low. In this example:

$$\begin{aligned} V_{CC} &= +5V = \text{logic high} \\ \text{GND} &= 0V = \text{logic low} \end{aligned}$$

The maximum analog voltage swings are determined by the supply voltages V_{CC} and V_{EE} . The positive peak analog voltage should not exceed V_{CC} . Similarly, the negative peak analog voltage should not go below V_{EE} . In this example, the difference between V_{CC} and V_{EE} is ten volts. Therefore, using the configuration of Figure 28, a maximum analog signal of ten volts peak-to-peak can be controlled. Unused analog inputs/outputs may be left floating (i.e., not connected). However, tying unused analog inputs and

outputs to V_{CC} or GND through a low value resistor helps minimize crosstalk and feedthrough noise that may be picked up by an unused switch.

Although used here, balanced supplies are not a requirement. The only constraints on the power supplies are that:

$$\begin{aligned} V_{CC} - \text{GND} &= 2 \text{ to } 6 \text{ volts} \\ V_{EE} - \text{GND} &= 0 \text{ to } -6 \text{ volts} \\ V_{CC} - V_{EE} &= 2 \text{ to } 12 \text{ volts} \\ &\text{and } V_{EE} \leq \text{GND} \end{aligned}$$

When voltage transients above V_{CC} and/or below V_{EE} are anticipated on the analog channels, external Germanium or Schottky diodes (D_x) are recommended as shown in Figure 29. These diodes should be able to absorb the maximum anticipated current surges during clipping.

MC74VHC4051, MC74VHC4052, MC74VHC4053

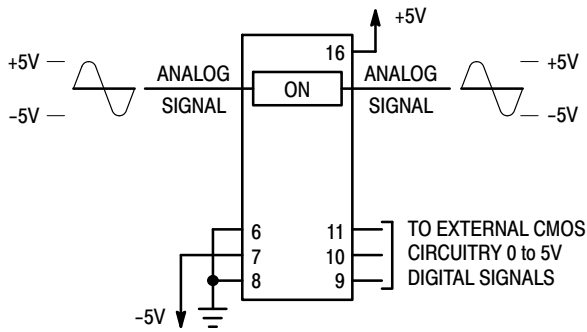

Figure 28. Application Example

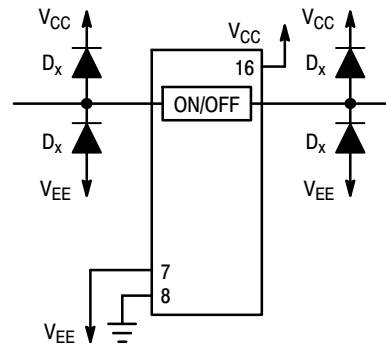
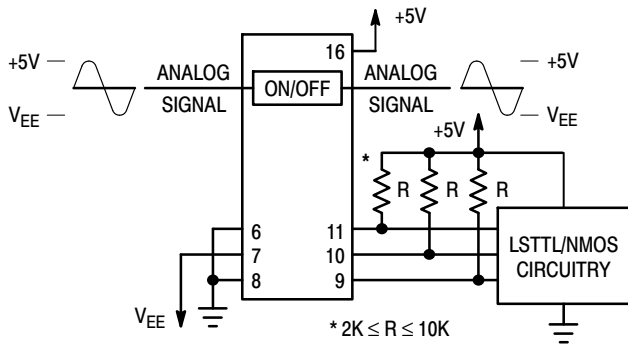
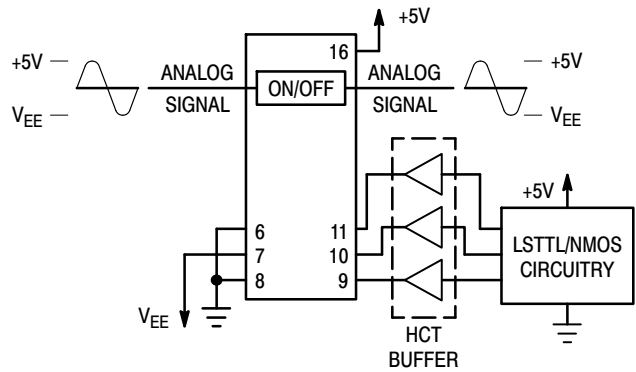

Figure 29. External Germanium or Schottky Clipping Diodes



a. Using Pull-Up Resistors



b. Using HCT Interface

Figure 30. Interfacing LSTTL/NMOS to CMOS Inputs

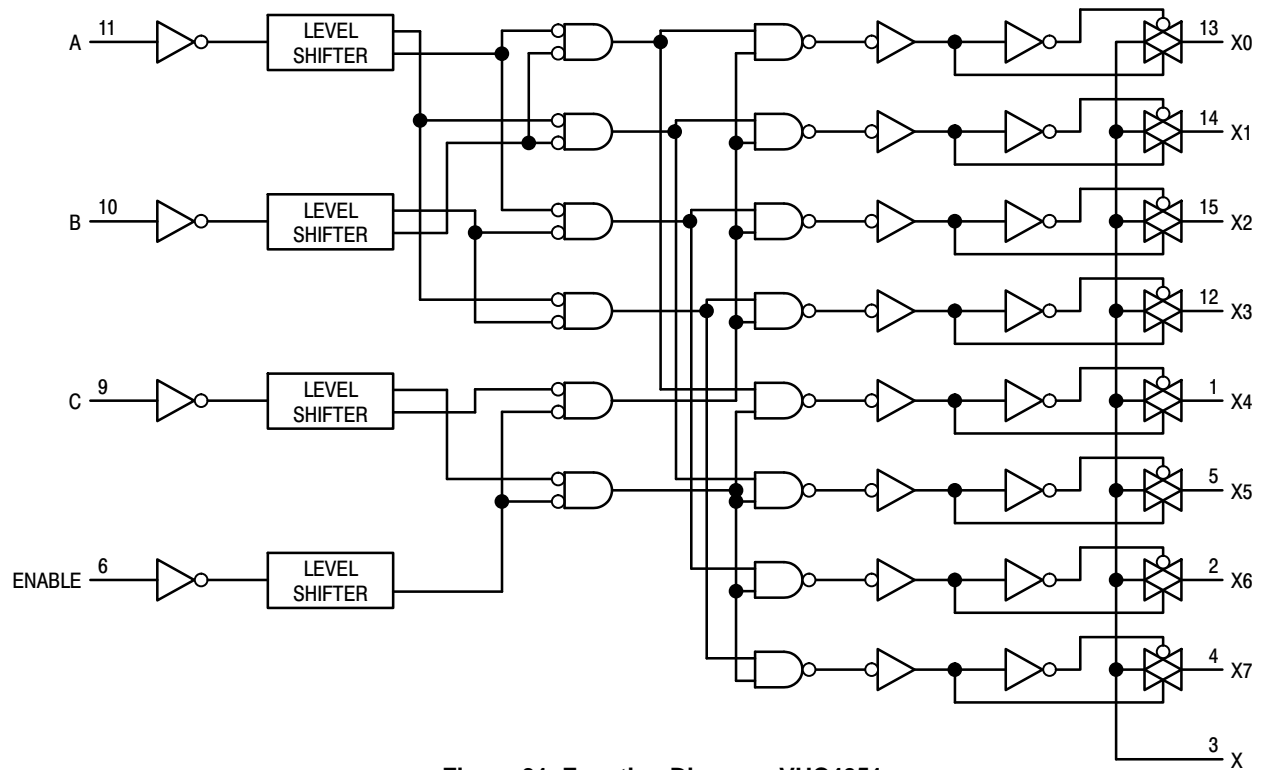

Figure 31. Function Diagram, VHC4051

MC74VHC4051, MC74VHC4052, MC74VHC4053

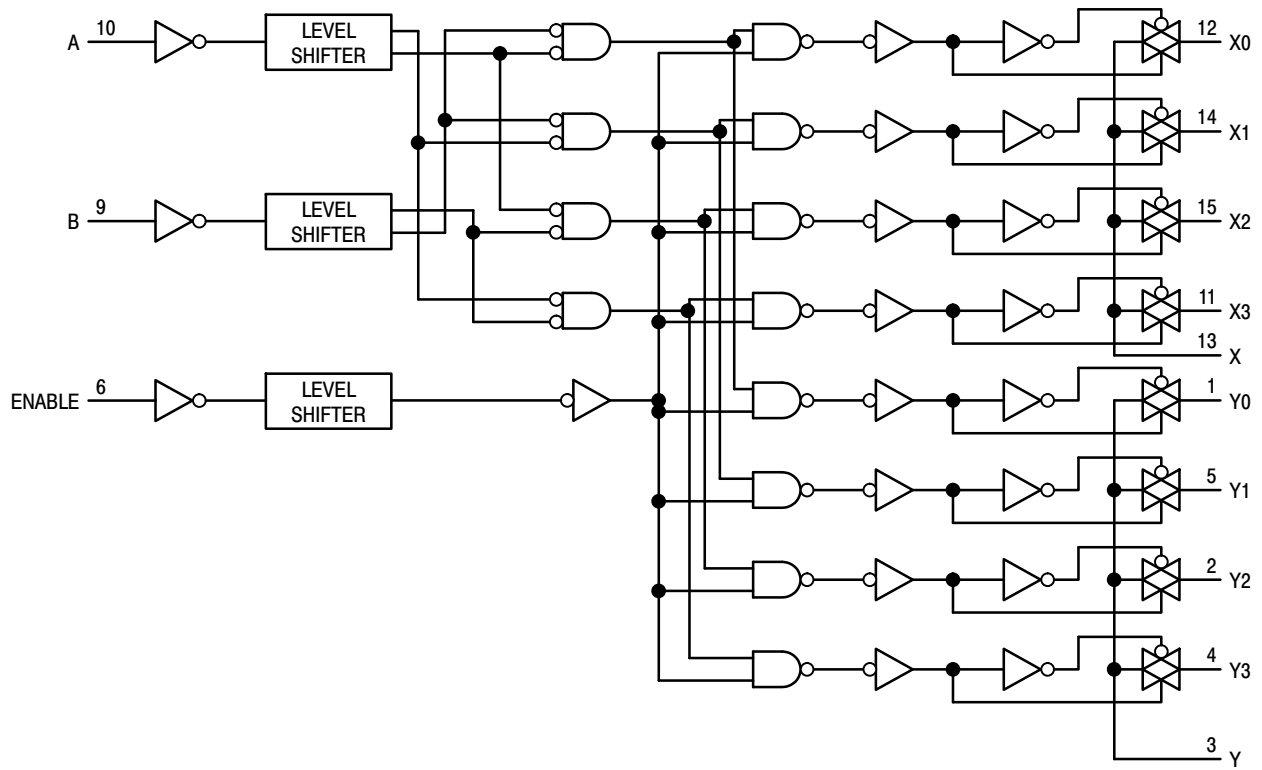

Figure 33. Function Diagram, VHC4052

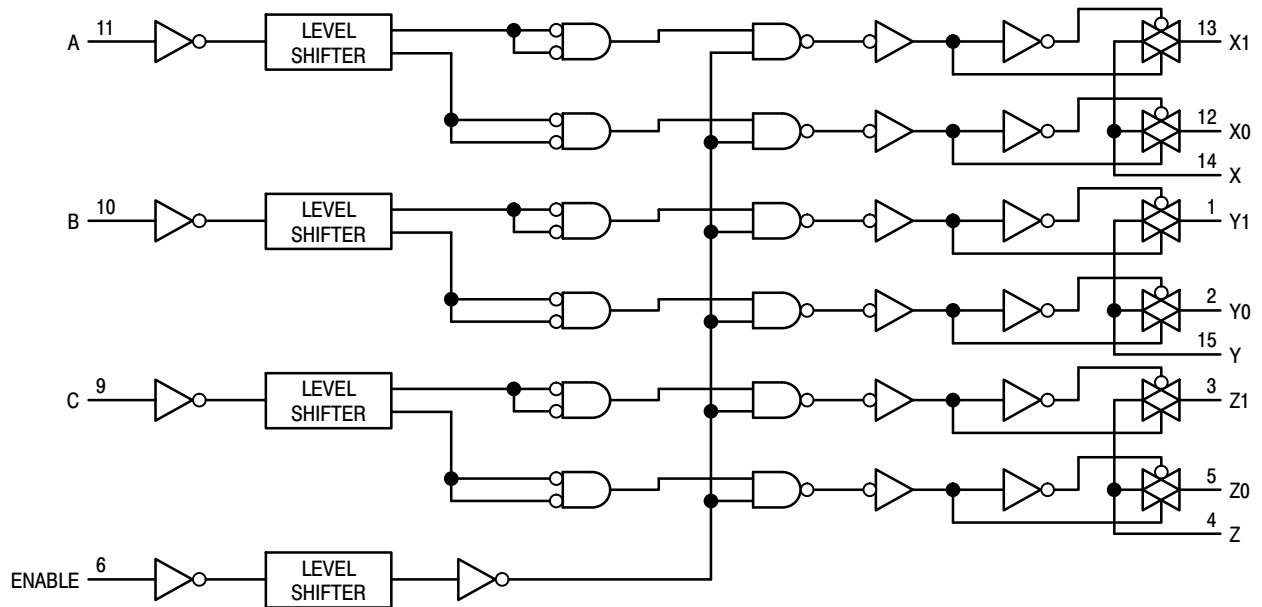

Figure 32. Function Diagram, VHC4053

MC74VHC4051, MC74VHC4052, MC74VHC4053

ORDERING & SHIPPING INFORMATION

Device	Package	Shipping [†]
MC74VHC4051DR2G	SOIC-16 (Pb-Free)	2500 / Tape & Reel
MC74VHC4052DR2G		
MC74VHC4053DR2G		
MC74VHC4051DTR2G	TSSOP-16 (Pb-Free)	2500 / Tape & Reel
MC74VHC4052DTR2G		
MC74VHC4053DTR2G		

[†]For information on tape and reel specifications, including part orientation and tape sizes, please refer to our Tape and Reel Packaging Specifications Brochure, BRD8011/D.

MC74VHC4051, MC74VHC4052, MC74VHC4053

PACKAGE DIMENSIONS

SOIC-16
CASE 751B-05
ISSUE K

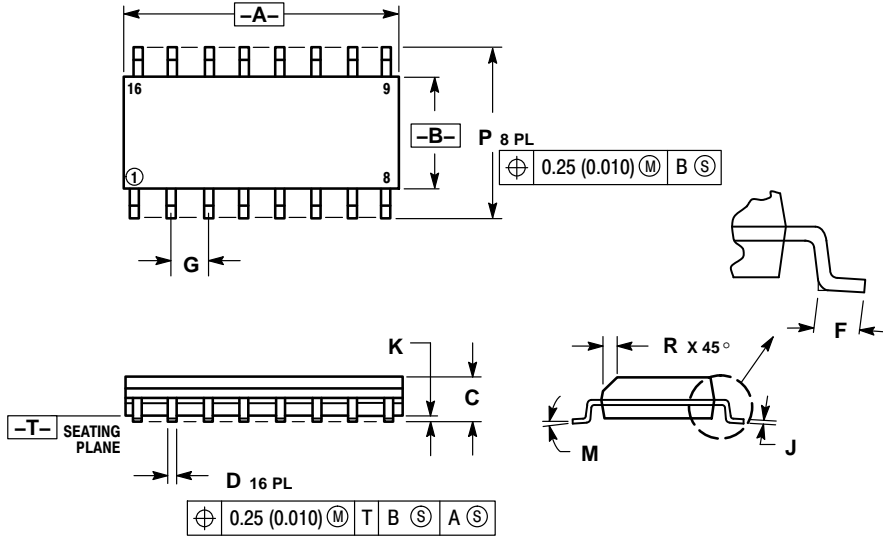

NOTES:

1. DIMENSIONING AND TOLERANCING PER ANSI Y14.5M, 1982.
2. CONTROLLING DIMENSION: MILLIMETER.
3. DIMENSIONS A AND B DO NOT INCLUDE MOLD PROTRUSION.
4. MAXIMUM MOLD PROTRUSION 0.15 (0.006) PER SIDE.
5. DIMENSION D DOES NOT INCLUDE DAMBAR PROTRUSION. ALLOWABLE DAMBAR PROTRUSION SHALL BE 0.127 (0.005) TOTAL IN EXCESS OF THE D DIMENSION AT MAXIMUM MATERIAL CONDITION.

DIM	MILLIMETERS		INCHES	
	MIN	MAX	MIN	MAX
A	9.80	10.00	0.386	0.393
B	3.80	4.00	0.150	0.157
C	1.35	1.75	0.054	0.068
D	0.35	0.49	0.014	0.019
F	0.40	1.25	0.016	0.049
G	1.27 BSC		0.050 BSC	
J	0.19	0.25	0.008	0.009
K	0.10	0.25	0.004	0.009
M	0°	7°	0°	7°
P	5.80	6.20	0.229	0.244
R	0.25	0.50	0.010	0.019

SOLDERING FOOTPRINT

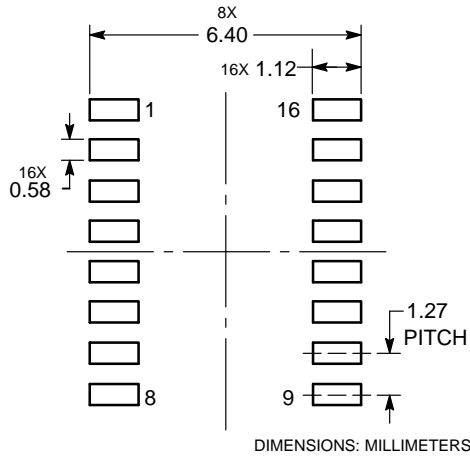

MC74VHC4051, MC74VHC4052, MC74VHC4053

PACKAGE DIMENSIONS

TSSOP-16
CASE 948F
ISSUE B

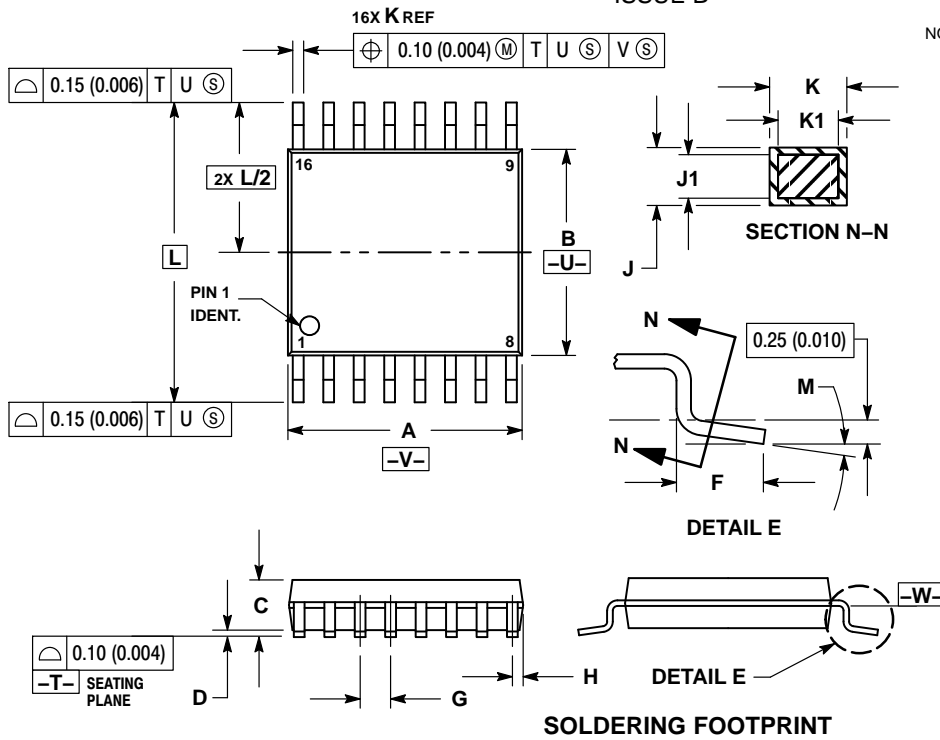

NOTES:

1. DIMENSIONING AND TOLERANCING PER ANSI Y14.5M, 1982.
2. CONTROLLING DIMENSION: MILLIMETER.
3. DIMENSION A DOES NOT INCLUDE MOLD FLASH, PROTRUSIONS OR GATE BURRS. MOLD FLASH OR GATE BURRS SHALL NOT EXCEED 0.15 (0.006) PER SIDE.
4. DIMENSION B DOES NOT INCLUDE INTERLEAD FLASH OR PROTRUSION. INTERLEAD FLASH OR PROTRUSION SHALL NOT EXCEED 0.25 (0.010) PER SIDE.
5. DIMENSION K DOES NOT INCLUDE DAMBAR PROTRUSION. ALLOWABLE DAMBAR PROTRUSION SHALL BE 0.08 (0.003) TOTAL IN EXCESS OF THE K DIMENSION AT MAXIMUM MATERIAL CONDITION.
6. TERMINAL NUMBERS ARE SHOWN FOR REFERENCE ONLY.
7. DIMENSION A AND B ARE TO BE DETERMINED AT DATUM PLANE -W-.

DIM	MILLIMETERS		INCHES	
	MIN	MAX	MIN	MAX
A	4.90	5.10	0.193	0.200
B	4.30	4.50	0.169	0.177
C	—	1.20	—	0.047
D	0.05	0.15	0.002	0.006
F	0.50	0.75	0.020	0.030
G	0.65 BSC		0.026 BSC	
H	0.18	0.28	0.007	0.011
J	0.09	0.20	0.004	0.008
J1	0.09	0.16	0.004	0.006
K	0.19	0.30	0.007	0.012
K1	0.19	0.25	0.007	0.010
L	6.40 BSC		0.252 BSC	
M	0°	8°	0°	8°

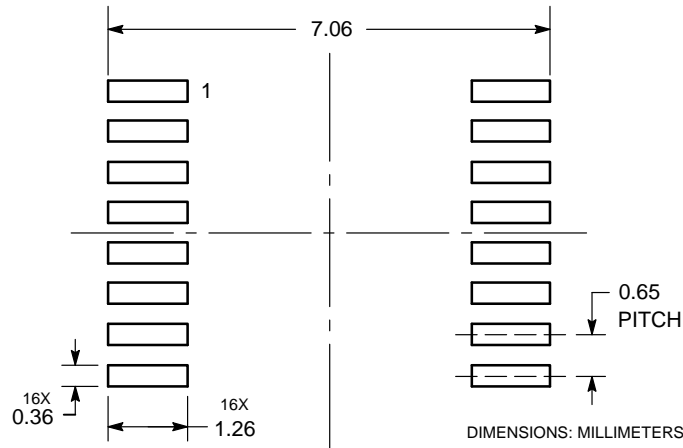

ON Semiconductor and the are registered trademarks of Semiconductor Components Industries, LLC (SCILLC) or its subsidiaries in the United States and/or other countries. SCILLC owns the rights to a number of patents, trademarks, copyrights, trade secrets, and other intellectual property. A listing of SCILLC's product/patent coverage may be accessed at www.onsemi.com/site/pdf/Patent-Marking.pdf. SCILLC reserves the right to make changes without further notice to any products herein. SCILLC makes no warranty, representation or guarantee regarding the suitability of its products for any particular purpose, nor does SCILLC assume any liability arising out of the application or use of any product or circuit, and specifically disclaims any and all liability, including without limitation special, consequential or incidental damages. "Typical" parameters which may be provided in SCILLC data sheets and/or specifications can and do vary in different applications and actual performance may vary over time. All operating parameters, including "Typicals" must be validated for each customer application by customer's technical experts. SCILLC does not convey any license under its patent rights nor the rights of others. SCILLC products are not designed, intended, or authorized for use as components in systems intended for surgical implant into the body, or other applications intended to support or sustain life, or for any other application in which the failure of the SCILLC product could create a situation where personal injury or death may occur. Should Buyer purchase or use SCILLC products for any such unintended or unauthorized application, Buyer shall indemnify and hold SCILLC and its officers, employees, subsidiaries, affiliates, and distributors harmless against all claims, costs, damages, and expenses, and reasonable attorney fees arising out of, directly or indirectly, any claim of personal injury or death associated with such unintended or unauthorized use, even if such claim alleges that SCILLC was negligent regarding the design or manufacture of the part. SCILLC is an Equal Opportunity/Affirmative Action Employer. This literature is subject to all applicable copyright laws and is not for resale in any manner.

PUBLICATION ORDERING INFORMATION

LITERATURE FULFILLMENT:

Literature Distribution Center for ON Semiconductor
P.O. Box 5163, Denver, Colorado 80217 USA
Phone: 303-675-2175 or 800-344-3860 Toll Free USA/Canada
Fax: 303-675-2176 or 800-344-3867 Toll Free USA/Canada
Email: orderlit@onsemi.com

N. American Technical Support: 800-282-9855 Toll Free
USA/Canada
Europe, Middle East and Africa Technical Support:
Phone: 421 33 790 2910
Japan Customer Focus Center
Phone: 81-3-5817-1050

ON Semiconductor Website: www.onsemi.com

Order Literature: <http://www.onsemi.com/orderlit>

For additional information, please contact your local Sales Representative

MC74VHC4051/D

Looking for pricing, stock, or lifecycle information?

Click below to explore more details on WIN SOURCE:

 [View MC74VHC4053DTR2G on WIN SOURCE](#)

 [ON Semiconductor](#) Information

Optimize Your Supply Chain with WIN SOURCE Solutions

-  Global Sourcing Solution
-  Obsolete Management
-  Cost Control Management
-  Shortage Management
-  Alternative Solution
-  Excess Inventory Management