



**THE DATASHEET OF  
MC74HC4851ADTR2G**



# Analog Multiplexers/ Demultiplexers with Injection Current Effect Control

Automotive Customized

## MC74HC4851A, MC74HC4852A, MC74HCT4851A, MC74HCT4852A

These devices are pin compatible to standard HC405x and MC1405xB analog mux/demux devices, but feature injection current effect control. This makes them especially suited for usage in automotive applications where voltages in excess of normal logic voltage are common.

The injection current effect control allows signals at disabled analog input channels to exceed the supply voltage range without affecting the signal of the enabled analog channel. This eliminates the need for external diode/resistor networks typically used to keep the analog channel signals within the supply voltage range.

The devices utilize low power silicon gate CMOS technology. The Channel Select and Enable inputs are compatible with standard CMOS outputs.

### Features

- Injection Current Cross-Coupling Less than 1 mV/mA (See Figure 10)
- Pin Compatible to HC405X and MC1405XB Devices
- Power Supply Range 2.0 to 6.0 V (HC), 4.5 to 5.5 V (HCT)
- In Compliance With the Requirements of JEDEC Standard No. 7 A
- Chip Complexity: 154 FETs or 36 Equivalent Gates
- -Q Suffix for Automotive and Other Applications Requiring Unique Site and Control Change Requirements; AEC-Q100 Qualified and PPAP Capable
- These Devices are Pb-Free, Halogen Free and are RoHS Compliant

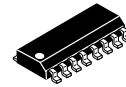

SOIC-16  
D SUFFIX  
CASE 751B

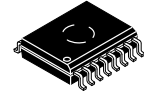

SOIC-16 WIDE  
DW SUFFIX  
CASE 751G

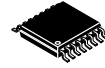

TSSOP-16  
DT SUFFIX  
CASE 948F



QFN16  
MN SUFFIX  
CASE 485AW

### MARKING DIAGRAMS

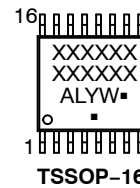
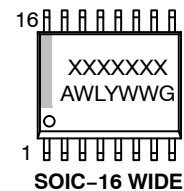
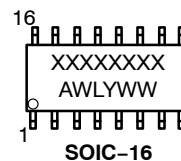

\*V4851 marking used for  
NLV74HC4851AMN1TWG

XXXXXXX = Specific Device Code  
A = Assembly Location  
WL, L = Wafer Lot  
YY, Y = Year  
WW, W = Work Week  
G or ■ = Pb-Free Package

(Note: Microdot may be in either location)

### ORDERING INFORMATION

See detailed ordering and shipping information on page 15 of this data sheet.

# MC74HC4851A, MC74HC4852A, MC74HCT4851A, MC74HCT4852A

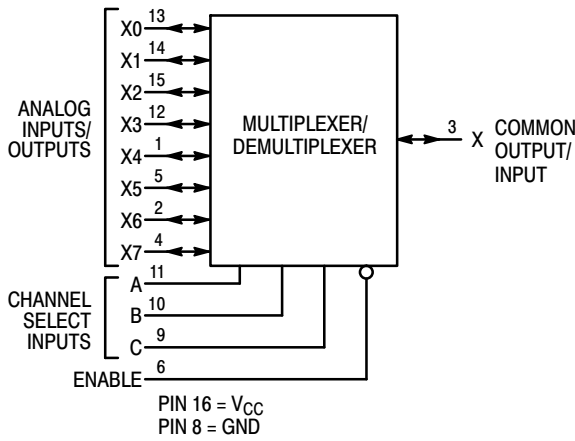

**Figure 1. 4851A Logic Diagram  
Single-Pole, 8-Position Plus Common Off**

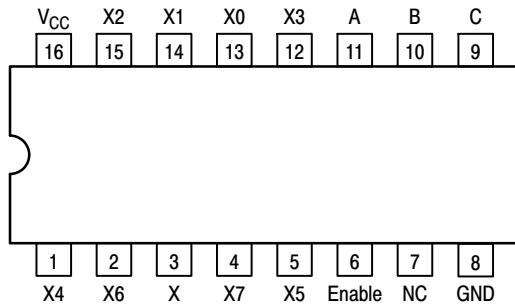

**Figure 2. 4851A 16-Lead Pinout (Top View)**

**FUNCTION TABLE - 4851A**

Control Inputs				ON Channels
Enable	Select			
	C	B	A	
L	L	L	L	X0
L	L	L	H	X1
L	L	H	L	X2
L	L	H	H	X3
L	H	L	L	X4
L	H	L	H	X5
L	H	H	L	X6
L	H	H	H	X7
H	X	X	X	NONE

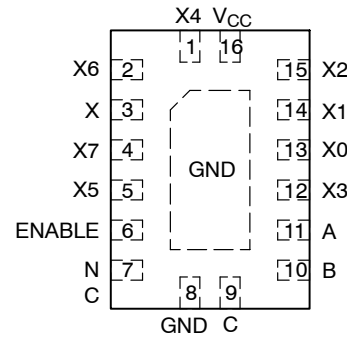
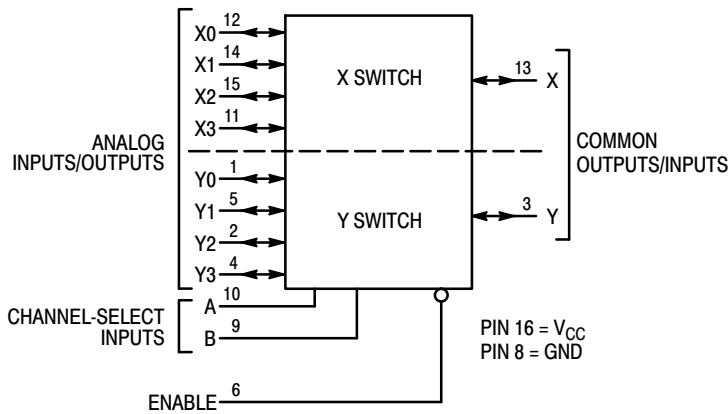

**Figure 3. 4851A QFN Pinout**

**FUNCTION TABLE - 4852A**

Control Inputs			ON Channels	
Enable	Select			
	B	A		
L	L	L	Y0	X0
L	L	H	Y1	X1
L	H	L	Y2	X2
L	H	H	Y3	X3
H	X	X	NONE	

X = Don't Care



**Figure 4. 4852A Logic Diagram  
Double-Pole, 4-Position Plus Common Off**

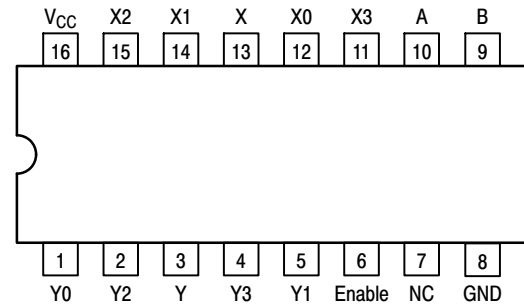

**Figure 5. 4852A 16-Lead Pinout (Top View)**

# MC74HC4851A, MC74HC4852A, MC74HCT4851A, MC74HCT4852A

## MAXIMUM RATINGS

Symbol	Parameter	Value	Unit	
V <sub>CC</sub>	DC Supply Voltage	-0.5 to +6.5	V	
V <sub>IN</sub>	DC Input Voltage	-0.5 to V <sub>CC</sub> +0.5	V	
I <sub>IN</sub>	DC Input Current, per Pin	±25	mA	
I <sub>CC</sub>	DC Supply Current, V <sub>CC</sub> and GND Pins	±50	mA	
I <sub>IK</sub>	Input Clamp Current (V <sub>IN</sub> < 0 or V <sub>IN</sub> > V <sub>CC</sub> )	±20	mA	
I <sub>OK</sub>	Output Clamp Current (V <sub>OUT</sub> < 0 or V <sub>OUT</sub> > V <sub>CC</sub> )	±20	mA	
T <sub>STG</sub>	Storage Temperature Range	-65 to +150	°C	
T <sub>L</sub>	Lead Temperature, 1 mm from Case for 10 secs	260	°C	
T <sub>J</sub>	Junction Temperature Under Bias	+150	°C	
θ <sub>JA</sub>	Thermal Resistance (Note 1)	SOIC-16 QFN16 TSSOP-16	126 118 159	°C/W
P <sub>D</sub>	Power Dissipation in Still Air at 25°C	SOIC-16 QFN16 TSSOP-16	995 1062 787	mW
MSL	Moisture Sensitivity	Level 1	-	
F <sub>R</sub>	Flammability Rating	Oxygen Index: 28 to 34	UL 94 V-0 @ 0.125 in	-
V <sub>ESD</sub>	ESD Withstand Voltage (Note 2)	Human Body Model Charged Device Model	> 2000 N/A	V

Stresses exceeding those listed in the Maximum Ratings table may damage the device. If any of these limits are exceeded, device functionality should not be assumed, damage may occur and reliability may be affected.

1. Measured with minimum pad spacing on an FR4 board, using 76 mm-by-114 mm, 2-ounce copper trace no air flow per JESD51-7.
2. HBM tested to EIA / JESD22-A114-A. CDM tested to JESD22-C101-A. JEDEC recommends that ESD qualification to EIA/JESD22-A115A (Machine Model) be discontinued.

## RECOMMENDED OPERATING CONDITIONS

Symbol	Parameter	Min	Max	Unit
--------	-----------	-----	-----	------

### MC74HC

V <sub>CC</sub>	DC Supply Voltage (Referenced to GND)	2.0	6.0	V
V <sub>IN</sub>	DC Input Voltage – Any Pin (Referenced to GND)	0	V <sub>CC</sub>	V
V <sub>IO*</sub>	Static or Dynamic Voltage Across Switch	0	1.2	V
T <sub>A</sub>	Operating Free-Air Temperature	-55	+125	°C
t <sub>r</sub> , t <sub>f</sub>	Input Rise or Fall Time	V <sub>CC</sub> = 2.0 V V <sub>CC</sub> = 4.5 V V <sub>CC</sub> = 6.0 V	0 1000 500 400	ns

### MC74HCT

V <sub>CC</sub>	DC Supply Voltage (Referenced to GND)	4.5	5.5	V
V <sub>IN</sub>	DC Input Voltage – Any Pin (Referenced to GND)	0	V <sub>CC</sub>	V
V <sub>IO*</sub>	Static or Dynamic Voltage Across Switch	0	1.2	V
T <sub>A</sub>	Operating Free-Air Temperature	-55	+125	°C
t <sub>r</sub> , t <sub>f</sub>	Input Rise or Fall Time	V <sub>CC</sub> = 4.5 V	0 500	ns

Functional operation above the stresses listed in the Recommended Operating Ranges is not implied. Extended exposure to stresses beyond the Recommended Operating Ranges limits may affect device reliability.

3. Unused inputs must always be tied to an appropriate logic voltage level (e.g., either GND or VCC). Unused outputs must be left open.

# MC74HC4851A, MC74HC4852A, MC74HCT4851A, MC74HCT4852A

## DC CHARACTERISTICS – Digital Section (MC74HC4851A, MC74HC4852A)

Symbol	Parameter	Condition	V <sub>CC</sub> V	Guaranteed Limit			Unit
				-55 to 25°C	≤85°C	≤125°C	
V <sub>IH</sub>	Minimum High-Level Input Voltage, Channel-Select or Enable Inputs	R <sub>on</sub> = Per Spec	2.0	1.50	1.50	1.50	V
			3.0	2.10	2.10	2.10	
			4.5	3.15	3.15	3.15	
			6.0	4.20	4.20	4.20	
V <sub>IL</sub>	Maximum Low-Level Input Voltage, Channel-Select or Enable Inputs	R <sub>on</sub> = Per Spec	2.0	0.50	0.50	0.50	V
			3.0	0.90	0.90	0.90	
			4.5	1.35	1.35	1.35	
			6.0	1.80	1.80	1.80	
I <sub>in</sub>	Maximum Input Leakage Current on Digital Pins (Enable/A/B/C)	V <sub>in</sub> = V <sub>CC</sub> or GND	6.0	±0.1	±1.0	±1.0	μA
I <sub>CC</sub>	Maximum Quiescent Supply Current (per Package)	V <sub>in(digital)</sub> = V <sub>CC</sub> or GND V <sub>in(analog)</sub> = GND	6.0	2	20	40	μA

Product parametric performance is indicated in the Electrical Characteristics for the listed test conditions, unless otherwise noted. Product performance may not be indicated by the Electrical Characteristics if operated under different conditions.

## DC CHARACTERISTICS – Analog Section (MC74HC4851A, MC74HC4852A)

Symbol	Parameter	Condition	V <sub>CC</sub>	Guaranteed Limit			Unit
				-55 to 25°C	≤85°C	≤125°C	
R <sub>on</sub>	Maximum "ON" Resistance	V <sub>in</sub> = V <sub>IL</sub> or V <sub>IH</sub> ; V <sub>IS</sub> = V <sub>CC</sub> to GND (Note 4); I <sub>S</sub> ≤ 2.0 mA (Note 5)	2.0	1700	1750	1800	Ω
			3.0	1100	1200	1300	
			4.5	550	650	750	
			6.0	400	500	600	
ΔR <sub>on</sub>	Delta "ON" Resistance	V <sub>in</sub> = V <sub>IL</sub> or V <sub>IH</sub> ; V <sub>IS</sub> = V <sub>CC</sub> /2 (Note 4); I <sub>S</sub> ≤ 2.0 mA (Note 5)	2.0	300	400	500	Ω
			3.0	160	200	240	
			4.5	80	100	120	
			6.0	60	80	100	
I <sub>off</sub>	Maximum Off-Channel Leakage Current, Any One Channel Common Channel	V <sub>in</sub> = V <sub>CC</sub> or GND	6.0	±0.1 ±0.1	±0.1 ±0.1	±0.1 ±0.1	μA
I <sub>on</sub>	Maximum On-Channel Leakage Channel-to-Channel	V <sub>in</sub> = V <sub>CC</sub> or GND	6.0	±0.1	±0.1	±0.1	μA

Product parametric performance is indicated in the Electrical Characteristics for the listed test conditions, unless otherwise noted. Product performance may not be indicated by the Electrical Characteristics if operated under different conditions.

4. V<sub>IS</sub> is the input voltage of an analog I/O pin.

5. I<sub>S</sub> is the current flowing in or out of analog I/O pin.

## AC CHARACTERISTICS (MC74HC4851A, MC74HC4852A) (C<sub>L</sub> = 50 pF)

Symbol	Parameter	V <sub>CC</sub>	-55 to 25°C	≤85°C	≤125°C	Unit
t <sub>PHL</sub> , t <sub>PLH</sub>	Maximum Propagation Delay, Analog Input to Analog Output	2.0	160	180	200	ns
		3.0	80	90	100	
		4.5	40	45	50	
		6.0	30	35	40	
t <sub>PHL</sub> , t <sub>PHZ,PZH</sub> t <sub>PLH</sub> , t <sub>PLZ,PZL</sub>	Maximum Propagation Delay, Enable or Channel-Select to Analog Output	2.0	260	280	300	ns
		3.0	160	180	200	
		4.5	80	90	100	
		6.0	78	80	80	
C <sub>in</sub>	Maximum Input Capacitance (All Switches Off) Any Single Analog Pin (All Switches Off) Common Analog Pin		10	10	10	pF
			35	35	35	
			40	40	40	
C <sub>PD</sub>	Power Dissipation Capacitance	Typical	5.0	20		pF

Product parametric performance is indicated in the Electrical Characteristics for the listed test conditions, unless otherwise noted. Product performance may not be indicated by the Electrical Characteristics if operated under different conditions.

# MC74HC4851A, MC74HC4852A, MC74HCT4851A, MC74HCT4852A

## INJECTION CURRENT COUPLING SPECIFICATIONS (MC74HC4851A, MC74HC4852A) ( $V_{CC} = 5\text{ V}$ , $T_A = -55^\circ\text{C}$ to $+125^\circ\text{C}$ )

Symbol	Parameter	Condition	Typ	Max	Unit
$V_{\Delta out}$	Maximum Shift of Output Voltage of Enabled Analog Channel	$I_{in}^* \leq 1\text{ mA}$ , $R_S \leq 3,9\text{ k}\Omega$ $I_{in}^* \leq 10\text{ mA}$ , $R_S \leq 3,9\text{ k}\Omega$ $I_{in}^* \leq 1\text{ mA}$ , $R_S \leq 20\text{ k}\Omega$ $I_{in}^* \leq 10\text{ mA}$ , $R_S \leq 20\text{ k}\Omega$	0.1 1.0 0.5 5.0	1.0 5.0 2.0 20	mV

\* $I_{in}$  = Total current injected into all disabled channels.

## DC CHARACTERISTICS – Digital Section (MC74HCT4851A, MC74HCT4852A)

Symbol	Parameter	Condition	$V_{CC}$ V	Guaranteed Limit			Unit
				$-55$ to $25^\circ\text{C}$	$\leq 85^\circ\text{C}$	$\leq 125^\circ\text{C}$	
$V_{IH}$	Minimum High-Level Input Voltage, Channel-Select or Enable Inputs	$R_{on} = \text{Per Spec}$	4.5 to 5.5	2.0	2.0	2.0	V
$V_{IL}$	Maximum Low-Level Input Voltage, Channel-Select or Enable Inputs	$R_{on} = \text{Per Spec}$	4.5 to 5.5	0.8	0.8	0.8	V
$I_{in}$	Maximum Input Leakage Current on Digital Pins (Enable/A/B/C)	$V_{in} = V_{CC}$ or GND	5.5	$\pm 0.1$	$\pm 1.0$	$\pm 1.0$	$\mu\text{A}$
$I_{CC}$	Maximum Quiescent Supply Current (per Package)	$V_{in(\text{digital})} = V_{CC}$ or GND $V_{in(\text{analog})} = \text{GND}$	5.5	2.0	20	40	$\mu\text{A}$

Product parametric performance is indicated in the Electrical Characteristics for the listed test conditions, unless otherwise noted. Product performance may not be indicated by the Electrical Characteristics if operated under different conditions.

## DC CHARACTERISTICS – Analog Section (MC74HCT4851A, MC74HCT4852A)

Symbol	Parameter	Condition	$V_{CC}$	Guaranteed Limit			Unit
				$-55$ to $25^\circ\text{C}$	$\leq 85^\circ\text{C}$	$\leq 125^\circ\text{C}$	
$R_{on}$	Maximum "ON" Resistance	$V_{in} = V_{IL}$ or $V_{IH}$ ; $V_{IS} = V_{CC}$ to GND (Note 4); $I_S \leq 2.0\text{ mA}$ (Note 5)	4.5 5.5	550 400	650 500	750 600	$\Omega$
$\Delta R_{on}$	Delta "ON" Resistance	$V_{in} = V_{IL}$ or $V_{IH}$ ; $V_{IS} = V_{CC}/2$ (Note 4); $I_S \leq 2.0\text{ mA}$ (Note 5)	4.5 5.5	80 60	100 80	120 100	$\Omega$
$I_{off}$	Maximum Off-Channel Leakage Current, Any One Channel Common Channel	$V_{in} = V_{CC}$ or GND	5.5	$\pm 0.1$ $\pm 0.1$	$\pm 0.1$ $\pm 0.1$	$\pm 0.1$ $\pm 0.1$	$\mu\text{A}$
$I_{on}$	Maximum On-Channel Leakage Channel-to-Channel	$V_{in} = V_{CC}$ or GND	5.5	$\pm 0.1$	$\pm 0.1$	$\pm 0.1$	$\mu\text{A}$

Product parametric performance is indicated in the Electrical Characteristics for the listed test conditions, unless otherwise noted. Product performance may not be indicated by the Electrical Characteristics if operated under different conditions.

# MC74HC4851A, MC74HC4852A, MC74HCT4851A, MC74HCT4852A

## AC CHARACTERISTICS (MC74HCT4851A, MC74HCT4852A) ( $C_L = 50$ pF)

Symbol	Parameter	$V_{CC}$	-55 to 25°C	≤85°C	≤125°C	Unit
$t_{PHL}$ , $t_{PLH}$	Maximum Propagation Delay, Analog Input to Analog Output	5.0	40	45	50	ns
$t_{PHL}$ , $t_{PHZ,PZH}$ , $t_{PLH}$ , $t_{PLZ,PZL}$	Maximum Propagation Delay, Enable or Channel-Select to Analog Output	5.0	80	90	100	ns
$C_{in}$	Maximum Input Capacitance (All Switches Off)					pF
	Digital Pins		10	10	10	
	Any Single Analog Pin		35	35	35	
	Common Analog Pin		40	40	40	
$C_{PD}$	Power Dissipation Capacitance Typical	5.0	20			pF

Product parametric performance is indicated in the Electrical Characteristics for the listed test conditions, unless otherwise noted. Product performance may not be indicated by the Electrical Characteristics if operated under different conditions.

## INJECTION CURRENT COUPLING SPECIFICATIONS (MC74HCT4851A, MC74HCT4852A) ( $V_{CC} = 5$ V, $T_A = -55^\circ\text{C}$ to $+125^\circ\text{C}$ )

Symbol	Parameter	Condition	Typ	Max	Unit
$V_{\Delta out}$	Maximum Shift of Output Voltage of Enabled Analog Channel	$I_{in}^* \leq 1$ mA, $R_S \leq 3,9$ k $\Omega$	0.1	1.0	mV
		$I_{in}^* \leq 10$ mA, $R_S \leq 3,9$ k $\Omega$	1.0	5.0	
		$I_{in}^* \leq 1$ mA, $R_S \leq 20$ k $\Omega$	0.5	2.0	
		$I_{in}^* \leq 10$ mA, $R_S \leq 20$ k $\Omega$	5.0	20	

\* $I_{in}$  = Total current injected into all disabled channels.

MC74HC4851A, MC74HC4852A, MC74HCT4851A, MC74HCT4852A

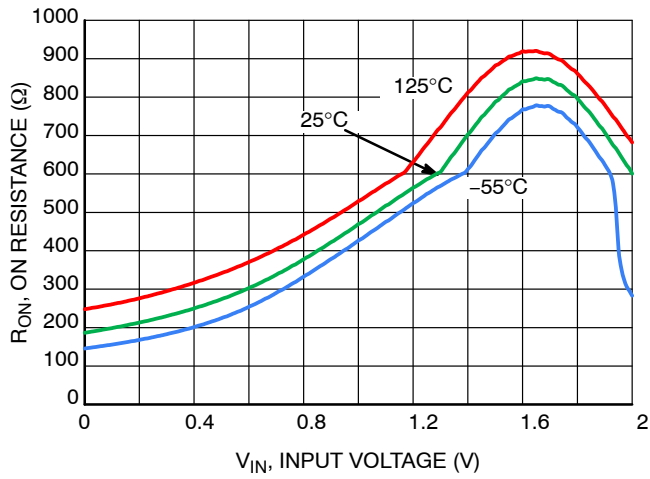

Figure 6. Typical On Resistance  $V_{CC} = 2\text{ V}$

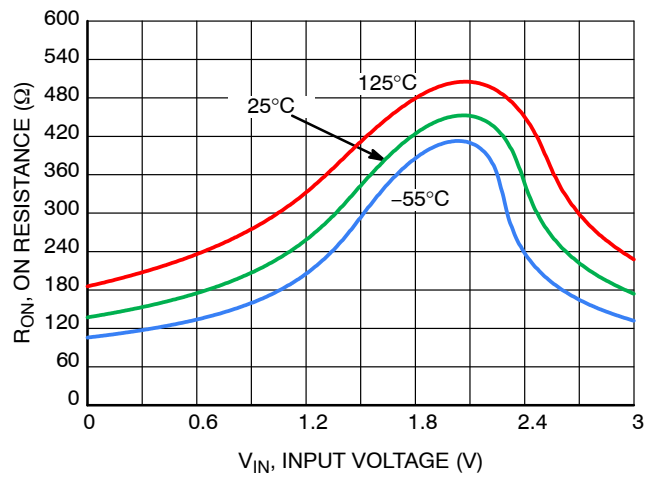

Figure 7. Typical On Resistance  $V_{CC} = 3\text{ V}$

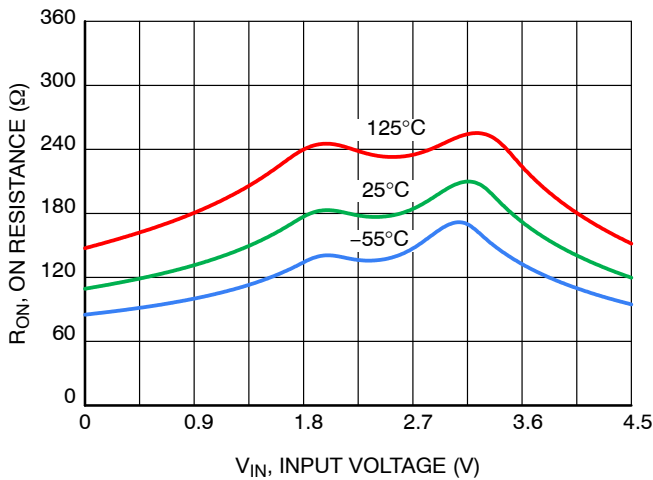

Figure 8. Typical On Resistance  $V_{CC} = 4.5\text{ V}$

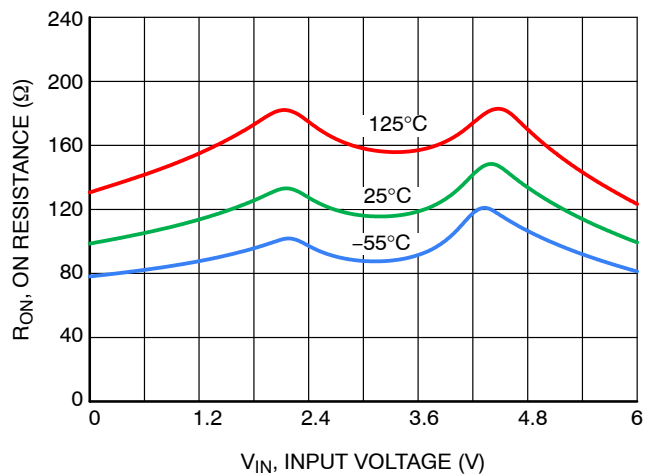

Figure 9. Typical On Resistance  $V_{CC} = 6\text{ V}$

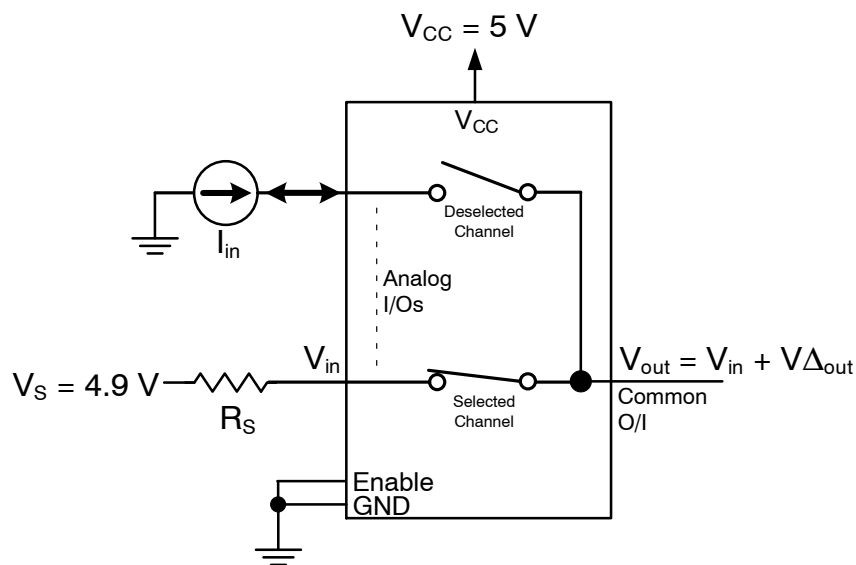

Figure 10. Injection Current Coupling Specification



TEST SETUPS

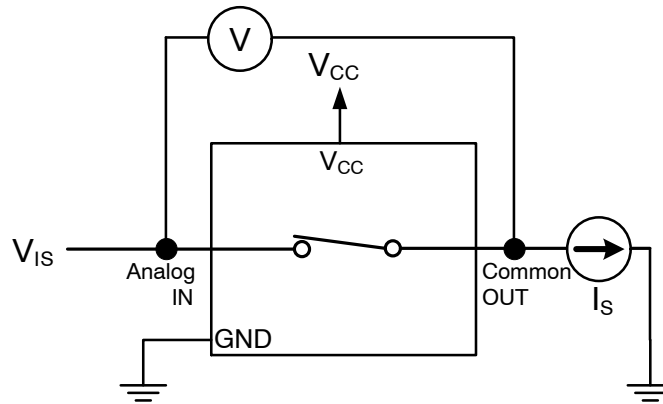

Figure 13. On Resistance

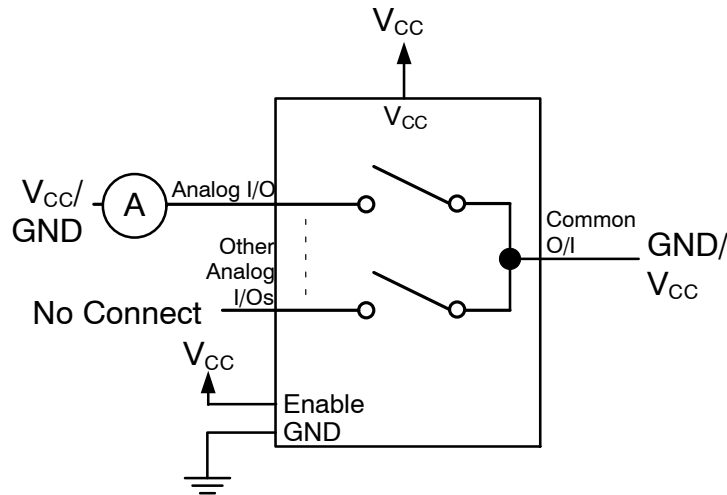

Figure 14. Maximum Off Channel Leakage Current, Any One Channel

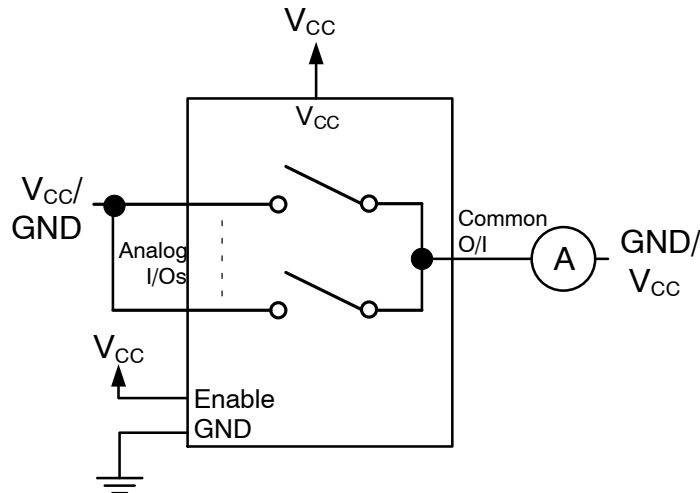

Figure 15. Maximum Off Channel Leakage Current, Common Channel

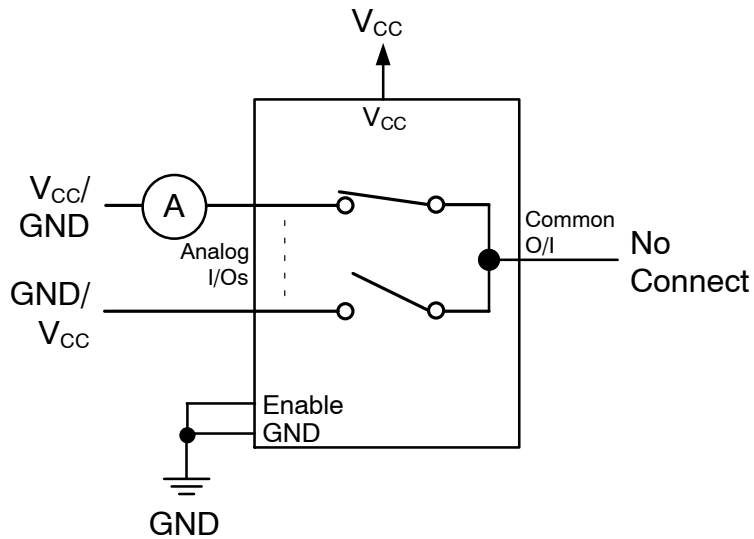
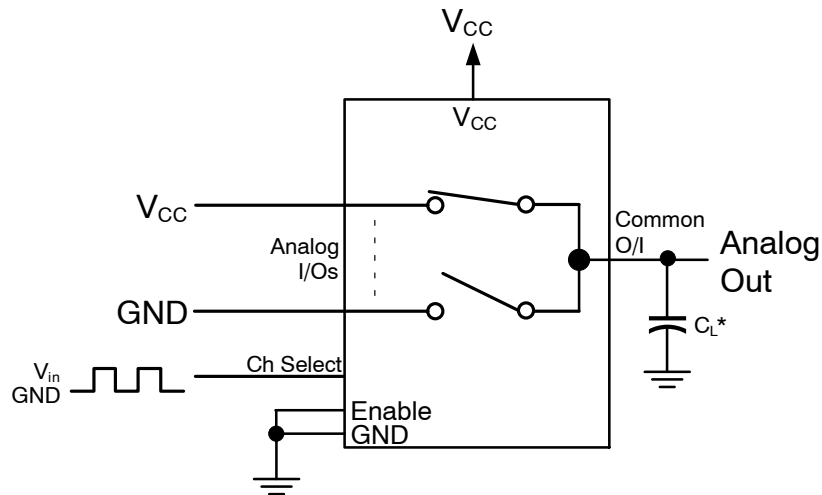
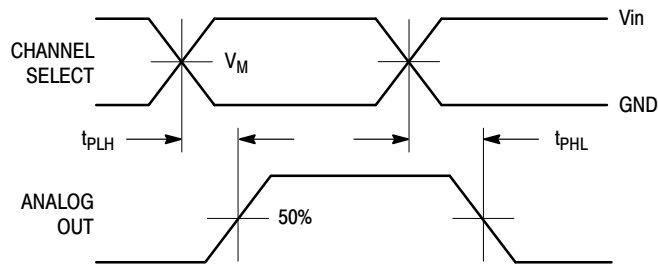

Figure 16. Maximum On Channel Leakage Current, Channel to Channel



\*Includes all probe and jig capacitance.



$V_{in} = V_{CC}$  for HC, 3 V for HCT  
 $V_M = 50\% \times V_{CC}$  for HC, 1.3 V for HCT

Figure 17. Propagation Delay, Channel Select to Analog Out

# MC74HC4851A, MC74HC4852A, MC74HCT4851A, MC74HCT4852A

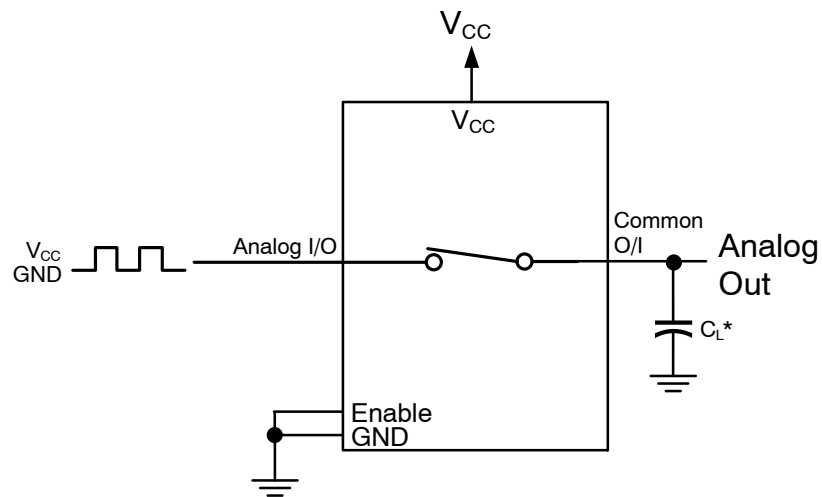

\*Includes all probe and jig capacitance.

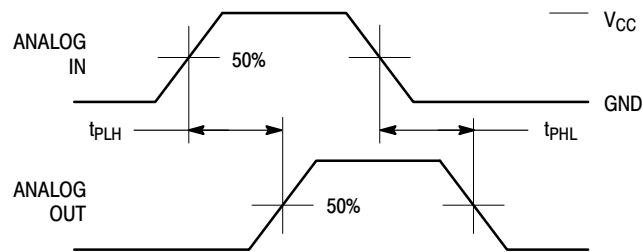
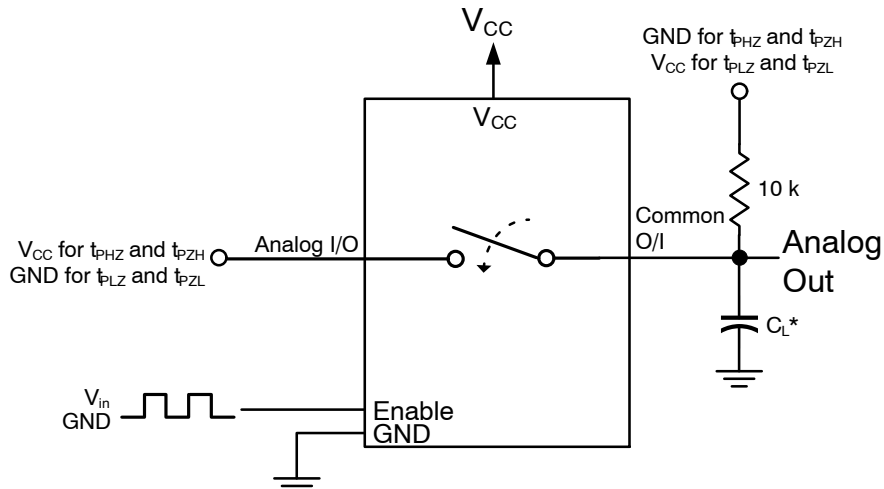

Figure 18. Propagation Delay, Analog In to Analog Out



\*Includes all probe and jig capacitance.

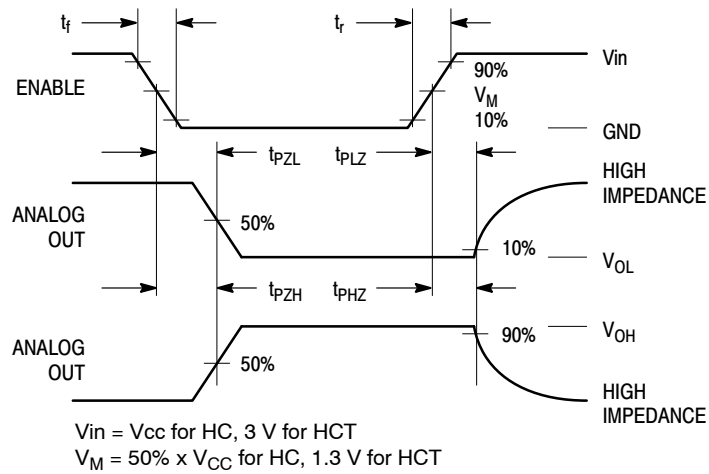

Figure 19. Propagation Delay, Enable to Analog Out

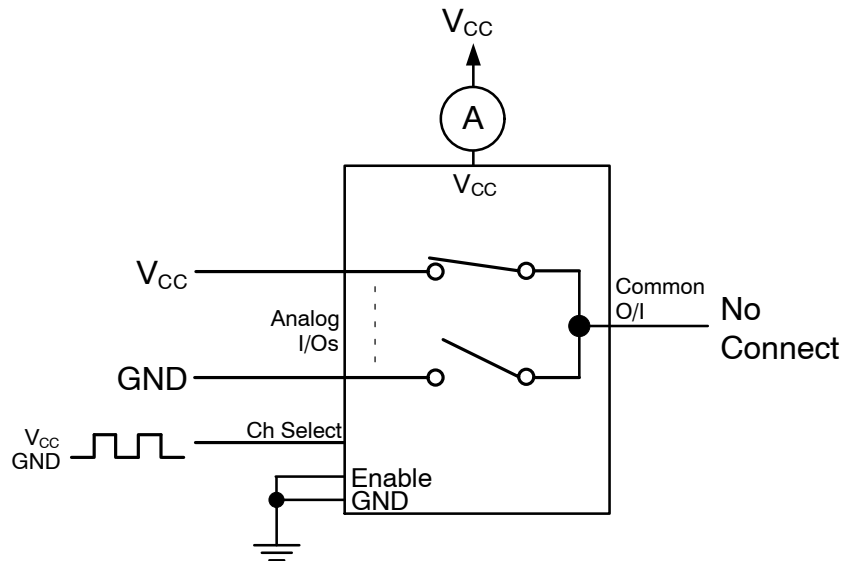
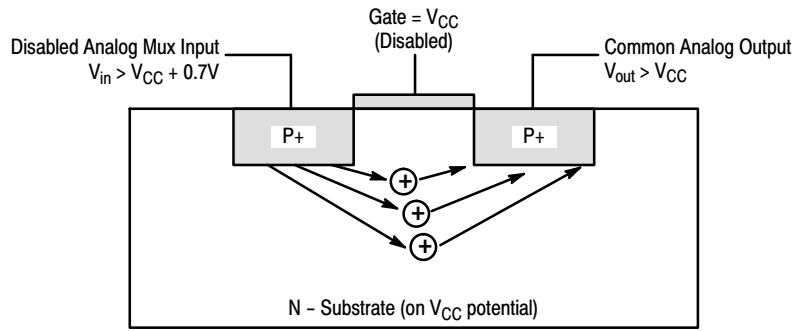
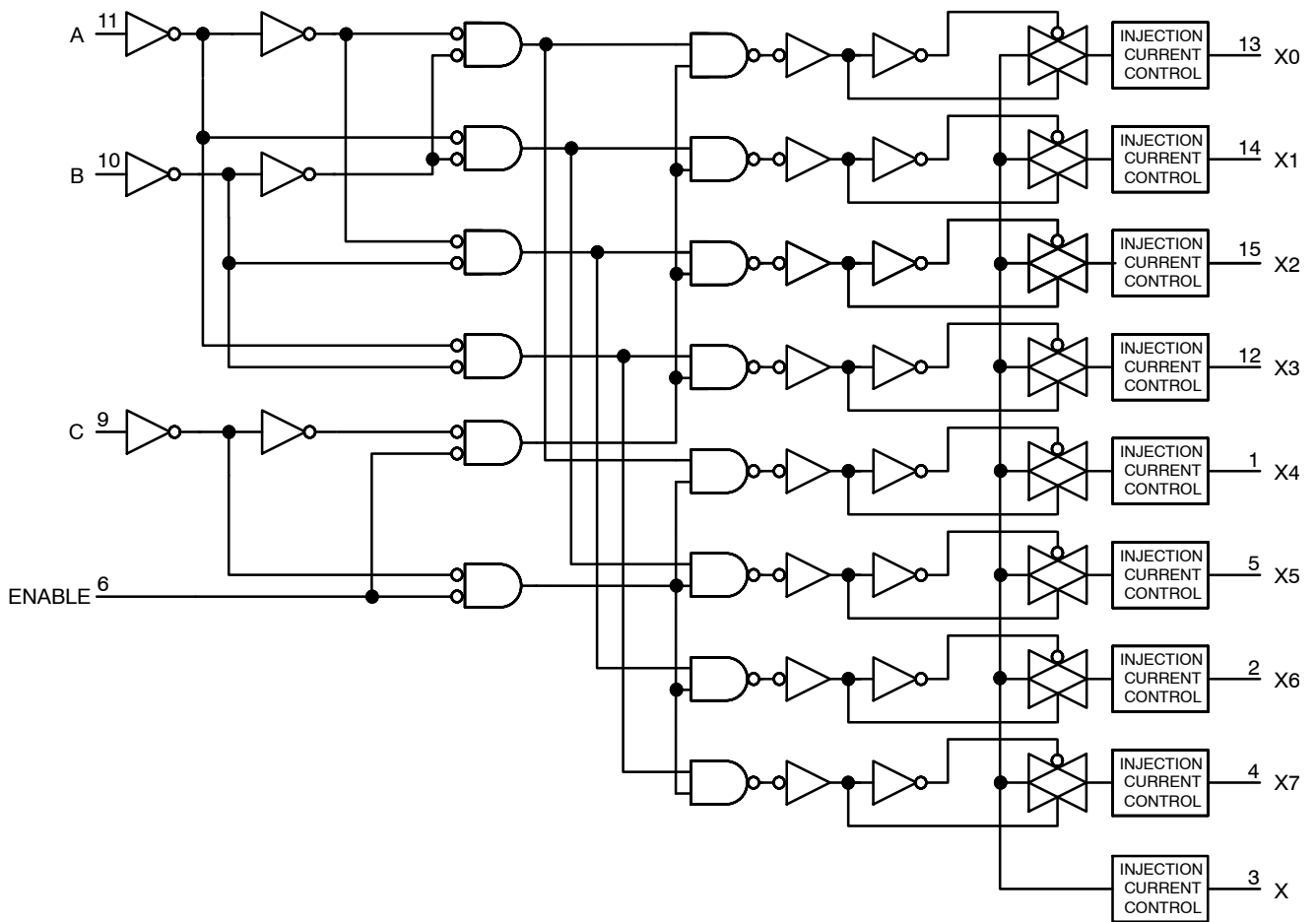

Figure 20. Power Dissipation Capacitance

MC74HC4851A, MC74HC4852A, MC74HCT4851A, MC74HCT4852A



**Figure 21. Diagram of Bipolar Coupling Mechanism**  
Appears if  $V_{in}$  exceeds  $V_{CC}$ , driving injection current into the substrate



**Figure 22. Function Diagram, 4851A**

MC74HC4851A, MC74HC4852A, MC74HCT4851A, MC74HCT4852A

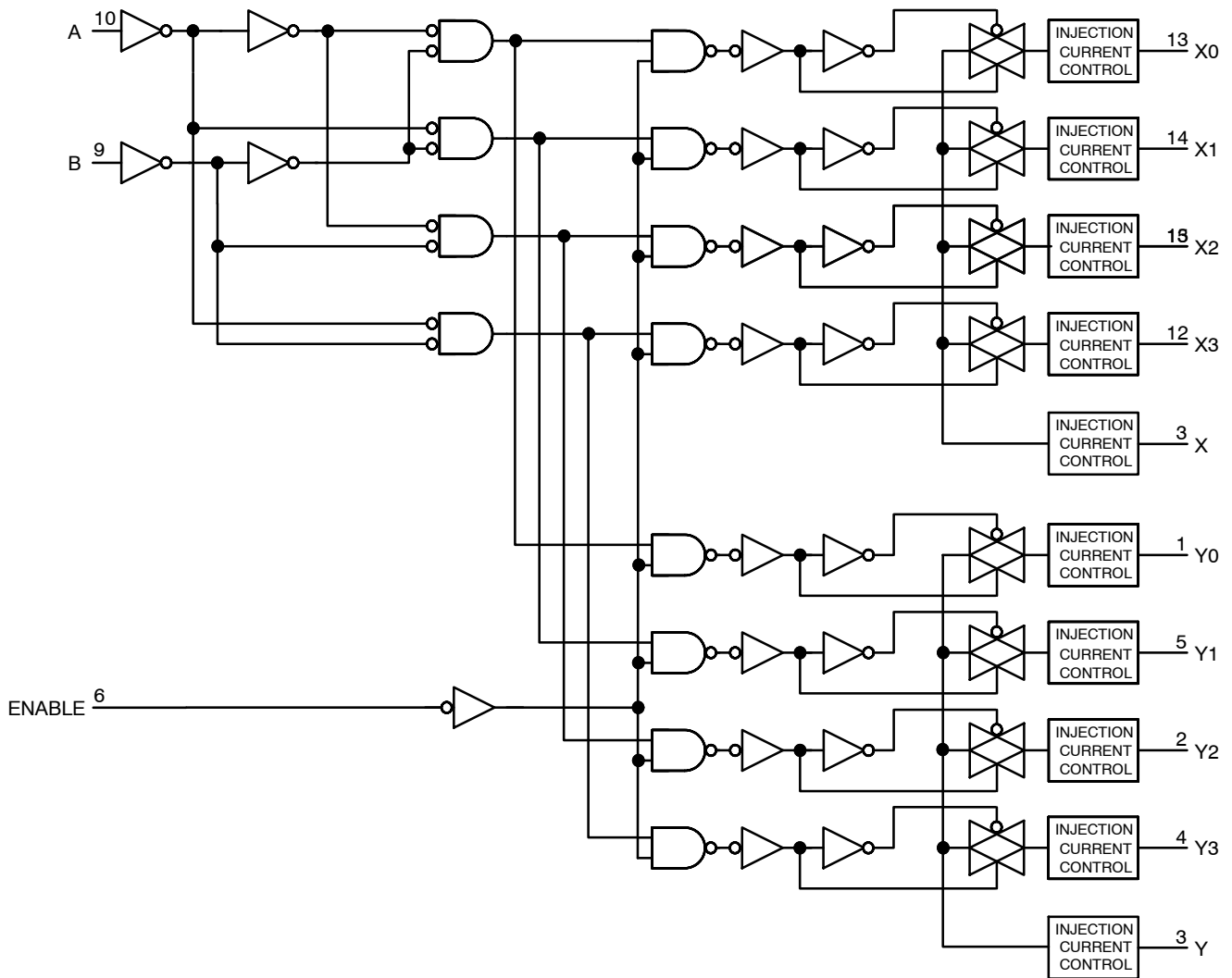

Figure 23. Function Diagram, 4852A

## MC74HC4851A, MC74HC4852A, MC74HCT4851A, MC74HCT4852A

### ORDERING INFORMATION

Device	Marking	Package	Shipping <sup>†</sup>
MC74HC4851ADG	HC4851AG	SOIC-16	55 Units / Rail
MC74HC4851ADR2G	HC4851AG	SOIC-16	2500 / Tape & Reel
MC74HC4851ADR2G-Q*	HC4851AG	SOIC-16	2500 / Tape & Reel
MC74HC4851ADTR2G	HC48 51A	TSSOP-16	2500 / Tape & Reel
MC74HC4851ADTR2G-Q*	HC48 51A	TSSOP-16	2500 / Tape & Reel
MC74HC4851AMN1TWG-Q*	4851	QFN-16	3000 / Tape & Reel
MC74HC4852ADR2G	HC4852AG	SOIC-16	2500 / Tape & Reel
MC74HC4852ADR2G-Q*	HC4852AG	SOIC-16	2500 / Tape & Reel
MC74HC4852ADTR2G	HC48 52A	TSSOP-16	2500 / Tape & Reel
MC74HC4852ADTR2G-Q*	HC48 52A	TSSOP-16	2500 / Tape & Reel
MC74HCT4851ADR2G	HCT4851AG	SOIC-16	2500 / Tape & Reel
MC74HCT4851ADTR2G	HCT4 851A	TSSOP-16	2500 / Tape & Reel
MC74HCT4851ADTR2G-Q*	HCT4 851A	TSSOP-16	2500 / Tape & Reel
MC74HCT4852ADR2G	HCT4852AG	SOIC-16	2500 / Tape & Reel
MC74HCT4852ADTR2G	HCT4 852A	TSSOP-16	2500 / Tape & Reel

<sup>†</sup>For information on tape and reel specifications, including part orientation and tape sizes, please refer to our Tape and Reel Packaging Specifications Brochure, BRD8011/D.

\*-Q Suffix for Automotive and Other Applications Requiring Unique Site and Control Change Requirements; AEC-Q100 Qualified and PPAP Capable.

# MC74HC4851A, MC74HC4852A, MC74HCT4851A, MC74HCT4852A

## PACKAGE DIMENSIONS

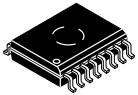

1  
SCALE 1:1

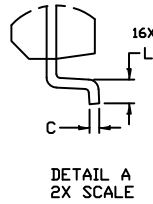
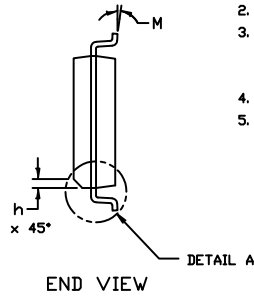
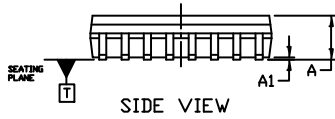
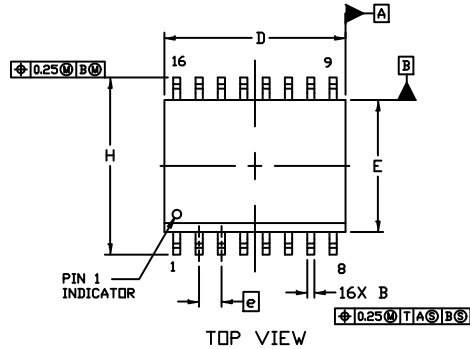

NOTES:

1. DIMENSIONING AND TOLERANCING PER ASME Y14.5M, 1994.
2. CONTROLLING DIMENSION: MILLIMETERS
3. DIMENSION b DOES NOT INCLUDE DAMBAR PROTRUSION. ALLOWABLE PROTRUSION SHALL BE 0.13 TOTAL IN EXCESS OF B DIMENSION AT MAXIMUM MATERIAL CONDITION.
4. DIMENSIONS D AND E DO NOT INCLUDE MOLD PROTRUSIONS.
5. MAXIMUM MOLD PROTRUSION OR FLASH TO BE 0.15 PER SIDE.

DIM	MILLIMETERS	
	MIN.	MAX.
A	2.35	2.65
A1	0.10	0.25
B	0.35	0.49
C	0.23	0.32
D	10.15	10.45
E	7.40	7.60
e	1.27 BSC	
H	10.05	10.55
h	0.53 REF	
L	0.50	0.90
M	0°	7°

### GENERIC MARKING DIAGRAM\*

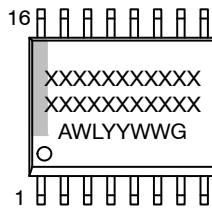

- XXXXXX = Specific Device Code
- A = Assembly Location
- WL = Wafer Lot
- YY = Year
- WW = Work Week
- G = Pb-Free Package

\*This information is generic. Please refer to device data sheet for actual part marking. Pb-Free indicator, "G" or microdot "•", may or may not be present. Some products may not follow the Generic Marking.

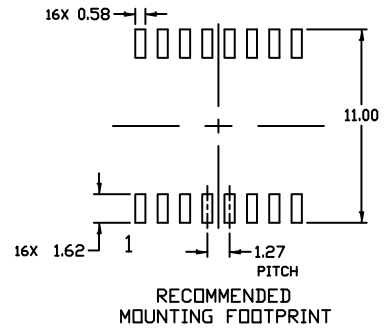

# MC74HC4851A, MC74HC4852A, MC74HCT4851A, MC74HCT4852A

## PACKAGE DIMENSIONS



SCALE 2:1

QFN16, 2.5x3.5, 0.5P  
CASE 485AW  
ISSUE O

DATE 11 DEC 2008

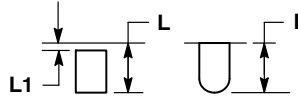
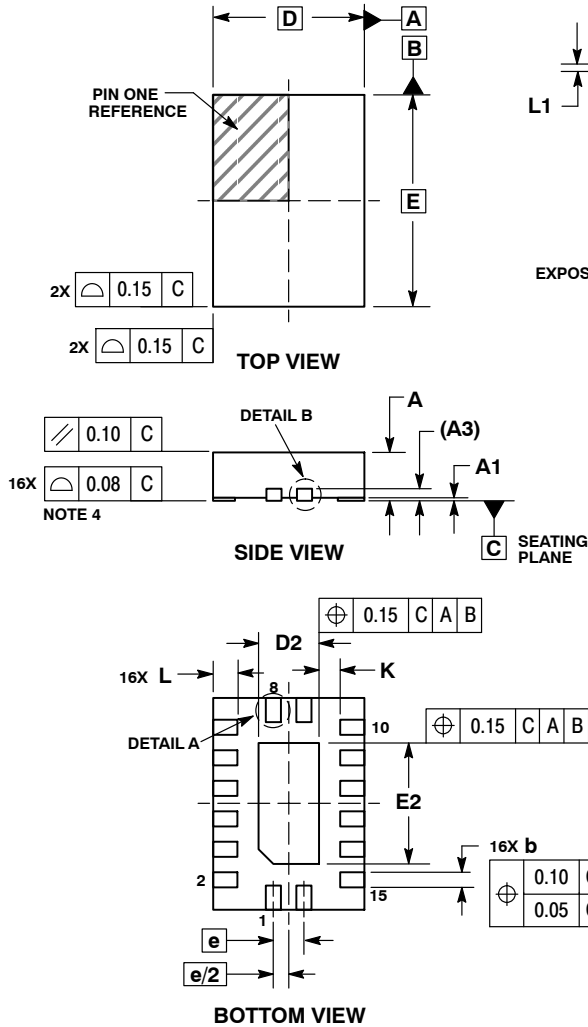

**DETAIL A**  
ALTERNATE TERMINAL  
CONSTRUCTIONS

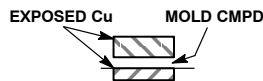

**DETAIL B**  
ALTERNATE  
CONSTRUCTIONS

NOTES:

1. DIMENSIONING AND TOLERANCING PER ASME Y14.5M, 1994.
2. CONTROLLING DIMENSION: MILLIMETERS.
3. DIMENSIONS b APPLIES TO PLATED TERMINAL AND IS MEASURED BETWEEN 0.15 AND 0.30 MM FROM TERMINAL.
4. COPLANARITY APPLIES TO THE EXPOSED PAD AS WELL AS THE TERMINALS.

MILLIMETERS		
DIM	MIN	MAX
A	0.80	1.00
A1	0.00	0.05
A3	0.20 REF	
b	0.20	0.30
D	2.50 BSC	
D2	0.85	1.15
E	3.50 BSC	
E2	1.85	2.15
e	0.50 BSC	
K	0.20	---
L	0.35	0.45
L1	---	0.15

**GENERIC MARKING  
DIAGRAM\***

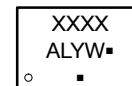

- XXXX = Specific Device Code
- A = Assembly Location
- L = Wafer Lot
- Y = Year
- W = Work Week
- = Pb-Free Package

(Note: Microdot may be in either location)

\*This information is generic. Please refer to device data sheet for actual part marking. Pb-Free indicator, "G" or microdot "▪", may or may not be present. Some products may not follow the Generic Marking.

**RECOMMENDED  
SOLDERING FOOTPRINT\***

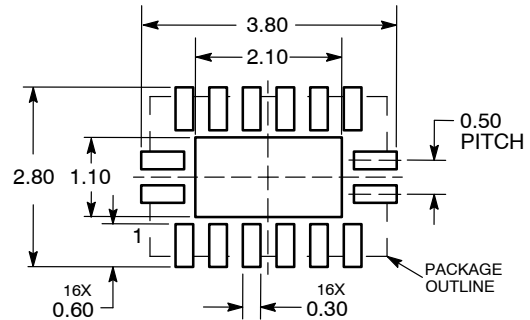

DIMENSIONS: MILLIMETERS

\*For additional information on our Pb-Free strategy and soldering details, please download the **onsemi** Soldering and Mounting Techniques Reference Manual, SOLDERRM/D.

# MECHANICAL CASE OUTLINE PACKAGE DIMENSIONS

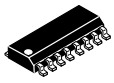

SCALE 1:1

SOIC-16  
CASE 751B-05  
ISSUE K

DATE 29 DEC 2006

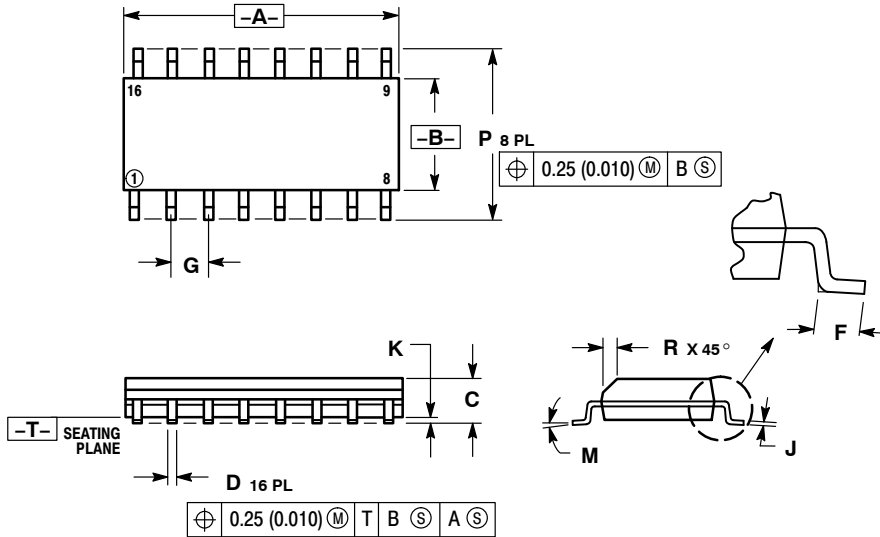

NOTES:

1. DIMENSIONING AND TOLERANCING PER ANSI Y14.5M, 1982.
2. CONTROLLING DIMENSION: MILLIMETER.
3. DIMENSIONS A AND B DO NOT INCLUDE MOLD PROTRUSION.
4. MAXIMUM MOLD PROTRUSION 0.15 (0.006) PER SIDE.
5. DIMENSION D DOES NOT INCLUDE DAMBAR PROTRUSION. ALLOWABLE DAMBAR PROTRUSION SHALL BE 0.127 (0.005) TOTAL IN EXCESS OF THE D DIMENSION AT MAXIMUM MATERIAL CONDITION.

DIM	MILLIMETERS		INCHES	
	MIN	MAX	MIN	MAX
A	9.80	10.00	0.386	0.393
B	3.80	4.00	0.150	0.157
C	1.35	1.75	0.054	0.068
D	0.35	0.49	0.014	0.019
F	0.40	1.25	0.016	0.049
G	1.27 BSC		0.050 BSC	
J	0.19	0.25	0.008	0.009
K	0.10	0.25	0.004	0.009
M	0° 7°		0° 7°	
P	5.80	6.20	0.229	0.244
R	0.25	0.50	0.010	0.019

- |  |  |  |  |
|--|--|--|--|
| <p>STYLE 1:</p> <p>PIN 1. COLLECTOR</p> <p>2. BASE</p> <p>3. EMITTER</p> <p>4. NO CONNECTION</p> <p>5. EMITTER</p> <p>6. BASE</p> <p>7. COLLECTOR</p> <p>8. COLLECTOR</p> <p>9. BASE</p> <p>10. EMITTER</p> <p>11. NO CONNECTION</p> <p>12. EMITTER</p> <p>13. BASE</p> <p>14. COLLECTOR</p> <p>15. EMITTER</p> <p>16. COLLECTOR</p>                           | <p>STYLE 2:</p> <p>PIN 1. CATHODE</p> <p>2. ANODE</p> <p>3. NO CONNECTION</p> <p>4. CATHODE</p> <p>5. CATHODE</p> <p>6. NO CONNECTION</p> <p>7. ANODE</p> <p>8. CATHODE</p> <p>9. CATHODE</p> <p>10. ANODE</p> <p>11. NO CONNECTION</p> <p>12. CATHODE</p> <p>13. CATHODE</p> <p>14. NO CONNECTION</p> <p>15. ANODE</p> <p>16. CATHODE</p> | <p>STYLE 3:</p> <p>PIN 1. COLLECTOR, DYE #1</p> <p>2. BASE, #1</p> <p>3. EMITTER, #1</p> <p>4. COLLECTOR, #1</p> <p>5. COLLECTOR, #2</p> <p>6. BASE, #2</p> <p>7. EMITTER, #2</p> <p>8. COLLECTOR, #2</p> <p>9. COLLECTOR, #3</p> <p>10. BASE, #3</p> <p>11. EMITTER, #3</p> <p>12. COLLECTOR, #3</p> <p>13. COLLECTOR, #4</p> <p>14. BASE, #4</p> <p>15. EMITTER, #4</p> <p>16. COLLECTOR, #4</p>   | <p>STYLE 4:</p> <p>PIN 1. COLLECTOR, DYE #1</p> <p>2. COLLECTOR, #1</p> <p>3. COLLECTOR, #2</p> <p>4. COLLECTOR, #2</p> <p>5. COLLECTOR, #3</p> <p>6. COLLECTOR, #3</p> <p>7. COLLECTOR, #4</p> <p>8. COLLECTOR, #4</p> <p>9. BASE, #4</p> <p>10. EMITTER, #4</p> <p>11. BASE, #3</p> <p>12. EMITTER, #3</p> <p>13. BASE, #2</p> <p>14. EMITTER, #2</p> <p>15. BASE, #1</p> <p>16. EMITTER, #1</p> |
| <p>STYLE 5:</p> <p>PIN 1. DRAIN, DYE #1</p> <p>2. DRAIN, #1</p> <p>3. DRAIN, #2</p> <p>4. DRAIN, #2</p> <p>5. DRAIN, #3</p> <p>6. DRAIN, #3</p> <p>7. DRAIN, #4</p> <p>8. DRAIN, #4</p> <p>9. GATE, #4</p> <p>10. SOURCE, #4</p> <p>11. GATE, #3</p> <p>12. SOURCE, #3</p> <p>13. GATE, #2</p> <p>14. SOURCE, #2</p> <p>15. GATE, #1</p> <p>16. SOURCE, #1</p> | <p>STYLE 6:</p> <p>PIN 1. CATHODE</p> <p>2. CATHODE</p> <p>3. CATHODE</p> <p>4. CATHODE</p> <p>5. CATHODE</p> <p>6. CATHODE</p> <p>7. CATHODE</p> <p>8. CATHODE</p> <p>9. ANODE</p> <p>10. ANODE</p> <p>11. ANODE</p> <p>12. ANODE</p> <p>13. ANODE</p> <p>14. ANODE</p> <p>15. ANODE</p> <p>16. ANODE</p>                                 | <p>STYLE 7:</p> <p>PIN 1. SOURCE N-CH</p> <p>2. COMMON DRAIN (OUTPUT)</p> <p>3. COMMON DRAIN (OUTPUT)</p> <p>4. GATE P-CH</p> <p>5. COMMON DRAIN (OUTPUT)</p> <p>6. COMMON DRAIN (OUTPUT)</p> <p>7. COMMON DRAIN (OUTPUT)</p> <p>8. SOURCE P-CH</p> <p>9. SOURCE P-CH</p> <p>10. COMMON DRAIN (OUTPUT)</p> <p>11. COMMON DRAIN (OUTPUT)</p> <p>12. COMMON DRAIN (OUTPUT)</p> <p>13. GATE N-CH</p> <p>14. COMMON DRAIN (OUTPUT)</p> <p>15. COMMON DRAIN (OUTPUT)</p> <p>16. SOURCE N-CH</p> |  |

RECOMMENDED  
SOLDERING FOOTPRINT\*

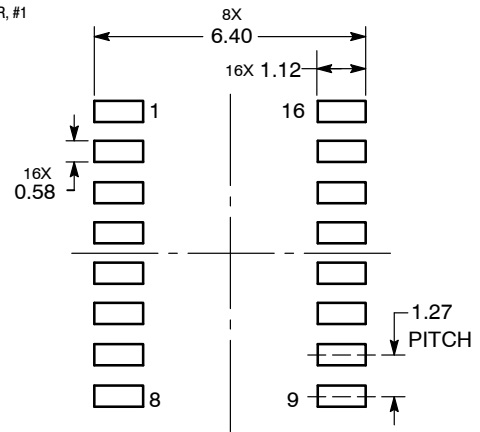

DIMENSIONS: MILLIMETERS

\*For additional information on our Pb-Free strategy and soldering details, please download the onsemi Soldering and Mounting Techniques Reference Manual, SOLDERRM/D.

DOCUMENT NUMBER:	98ASB42566B	Electronic versions are uncontrolled except when accessed directly from the Document Repository. Printed versions are uncontrolled except when stamped "CONTROLLED COPY" in red.
DESCRIPTION:	SOIC-16	PAGE 1 OF 1

onsemi and onsemi are trademarks of Semiconductor Components Industries, LLC dba onsemi or its subsidiaries in the United States and/or other countries. onsemi reserves the right to make changes without further notice to any products herein. onsemi makes no warranty, representation or guarantee regarding the suitability of its products for any particular purpose, nor does onsemi assume any liability arising out of the application or use of any product or circuit, and specifically disclaims any and all liability, including without limitation special, consequential or incidental damages. onsemi does not convey any license under its patent rights nor the rights of others.

# MECHANICAL CASE OUTLINE PACKAGE DIMENSIONS

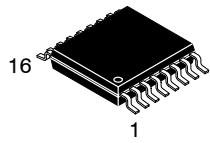

**TSSOP-16 WB**  
CASE 948F  
ISSUE B

DATE 19 OCT 2006

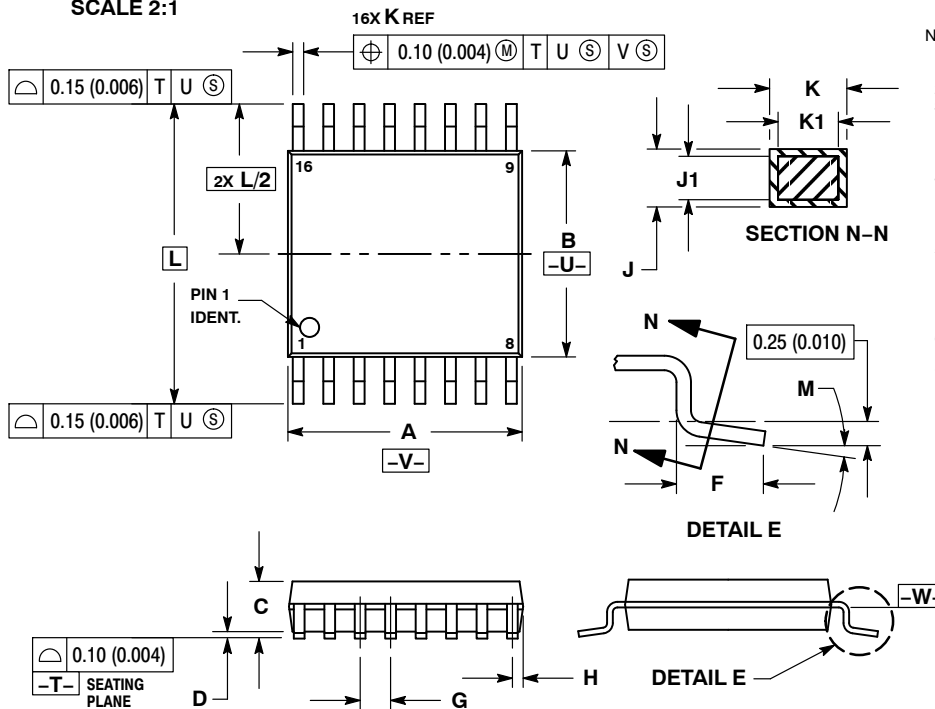

- NOTES:
1. DIMENSIONING AND TOLERANCING PER ANSI Y14.5M, 1982.
  2. CONTROLLING DIMENSION: MILLIMETER.
  3. DIMENSION A DOES NOT INCLUDE MOLD FLASH, PROTRUSIONS OR GATE BURRS. MOLD FLASH OR GATE BURRS SHALL NOT EXCEED 0.15 (0.006) PER SIDE.
  4. DIMENSION B DOES NOT INCLUDE INTERLEAD FLASH OR PROTRUSION. INTERLEAD FLASH OR PROTRUSION SHALL NOT EXCEED 0.25 (0.010) PER SIDE.
  5. DIMENSION K DOES NOT INCLUDE DAMBAR PROTRUSION. ALLOWABLE DAMBAR PROTRUSION SHALL BE 0.08 (0.003) TOTAL IN EXCESS OF THE K DIMENSION AT MAXIMUM MATERIAL CONDITION.
  6. TERMINAL NUMBERS ARE SHOWN FOR REFERENCE ONLY.
  7. DIMENSION A AND B ARE TO BE DETERMINED AT DATUM PLANE -W-.

DIM	MILLIMETERS		INCHES	
	MIN	MAX	MIN	MAX
A	4.90	5.10	0.193	0.200
B	4.30	4.50	0.169	0.177
C	---	1.20	---	0.047
D	0.05	0.15	0.002	0.006
F	0.50	0.75	0.020	0.030
G	0.65 BSC		0.026 BSC	
H	0.18	0.28	0.007	0.011
J	0.09	0.20	0.004	0.008
J1	0.09	0.16	0.004	0.006
K	0.19	0.30	0.007	0.012
K1	0.19	0.25	0.007	0.010
L	6.40 BSC		0.252 BSC	
M	0°	8°	0°	8°

### RECOMMENDED SOLDERING FOOTPRINT\*

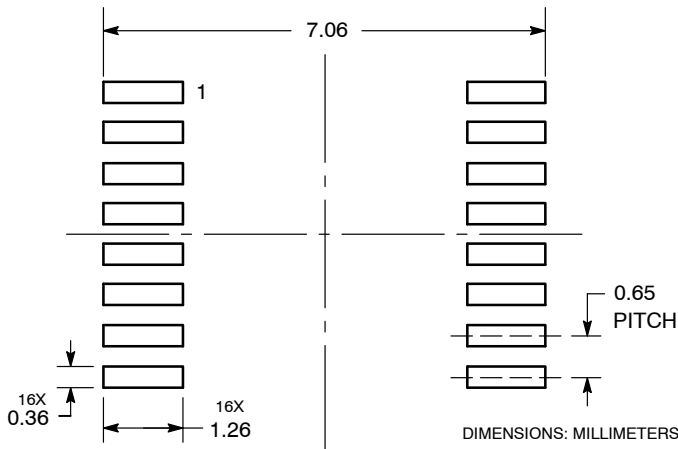

### GENERIC MARKING DIAGRAM\*

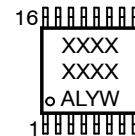

- XXXX = Specific Device Code
- A = Assembly Location
- L = Wafer Lot
- Y = Year
- W = Work Week
- G or ■ = Pb-Free Package

\*This information is generic. Please refer to device data sheet for actual part marking. Pb-Free indicator, "G" or microdot "■", may or may not be present. Some products may not follow the Generic Marking.

\*For additional information on our Pb-Free strategy and soldering details, please download the **onsemi** Soldering and Mounting Techniques Reference Manual, SOLDERRM/D.

<b>DOCUMENT NUMBER:</b>	<b>98ASH70247A</b>	Electronic versions are uncontrolled except when accessed directly from the Document Repository. Printed versions are uncontrolled except when stamped "CONTROLLED COPY" in red.
<b>DESCRIPTION:</b>	<b>TSSOP-16</b>	<b>PAGE 1 OF 1</b>

onsemi and onsemi are trademarks of Semiconductor Components Industries, LLC dba onsemi or its subsidiaries in the United States and/or other countries. onsemi reserves the right to make changes without further notice to any products herein. onsemi makes no warranty, representation or guarantee regarding the suitability of its products for any particular purpose, nor does onsemi assume any liability arising out of the application or use of any product or circuit, and specifically disclaims any and all liability, including without limitation special, consequential or incidental damages. onsemi does not convey any license under its patent rights nor the rights of others.

**onsemi**, **Onsemi**, and other names, marks, and brands are registered and/or common law trademarks of Semiconductor Components Industries, LLC dba "**onsemi**" or its affiliates and/or subsidiaries in the United States and/or other countries. **onsemi** owns the rights to a number of patents, trademarks, copyrights, trade secrets, and other intellectual property. A listing of **onsemi**'s product/patent coverage may be accessed at [www.onsemi.com/site/pdf/Patent-Marking.pdf](http://www.onsemi.com/site/pdf/Patent-Marking.pdf). **onsemi** reserves the right to make changes at any time to any products or information herein, without notice. The information herein is provided "as-is" and **onsemi** makes no warranty, representation or guarantee regarding the accuracy of the information, product features, availability, functionality, or suitability of its products for any particular purpose, nor does **onsemi** assume any liability arising out of the application or use of any product or circuit, and specifically disclaims any and all liability, including without limitation special, consequential or incidental damages. Buyer is responsible for its products and applications using **onsemi** products, including compliance with all laws, regulations and safety requirements or standards, regardless of any support or applications information provided by **onsemi**. "Typical" parameters which may be provided in **onsemi** data sheets and/or specifications can and do vary in different applications and actual performance may vary over time. All operating parameters, including "Typicals" must be validated for each customer application by customer's technical experts. **onsemi** does not convey any license under any of its intellectual property rights nor the rights of others. **onsemi** products are not designed, intended, or authorized for use as a critical component in life support systems or any FDA Class 3 medical devices or medical devices with a same or similar classification in a foreign jurisdiction or any devices intended for implantation in the human body. Should Buyer purchase or use **onsemi** products for any such unintended or unauthorized application, Buyer shall indemnify and hold **onsemi** and its officers, employees, subsidiaries, affiliates, and distributors harmless against all claims, costs, damages, and expenses, and reasonable attorney fees arising out of, directly or indirectly, any claim of personal injury or death associated with such unintended or unauthorized use, even if such claim alleges that **onsemi** was negligent regarding the design or manufacture of the part. **onsemi** is an Equal Opportunity/Affirmative Action Employer. This literature is subject to all applicable copyright laws and is not for resale in any manner.

## ADDITIONAL INFORMATION

### TECHNICAL PUBLICATIONS:

Technical Library: [www.onsemi.com/design/resources/technical-documentation](http://www.onsemi.com/design/resources/technical-documentation)  
onsemi Website: [www.onsemi.com](http://www.onsemi.com)

### ONLINE SUPPORT: [www.onsemi.com/support](http://www.onsemi.com/support)

For additional information, please contact your local Sales Representative at [www.onsemi.com/support/sales](http://www.onsemi.com/support/sales)

## Looking for pricing, stock, or lifecycle information?

Click below to explore more details on WIN SOURCE:

 [View MC74HC4851ADTR2G on WIN SOURCE](#)

 [ON Semiconductor](#) Information

## Optimize Your Supply Chain with WIN SOURCE Solutions

-  Global Sourcing Solution
-  Obsolete Management
-  Cost Control Management
-  Shortage Management
-  Alternative Solution
-  Excess Inventory Management