



**THE DATASHEET OF
MC74HC4094ADR2G**



MC74HC4094A

8-Bit Shift and Store Register

High-Performance Silicon-Gate CMOS

The MC74HC4094A is a high speed CMOS 8-bit serial shift and storage register. This device consists of an 8-bit shift register and latch with 3-state output buffers. Data is shifted on positive clock (CP) transitions. The data in the shift register is transferred to the storage register when the Strobe (STR) input is high. The output buffers are enabled when the Output Enable (OE) input is set high. Two serial outputs (QS₁, QS₂) are available for cascading multiple devices.

Features

- Wide Operating Voltage Range: 2.0 to 6.0 V
- Low Power Dissipation: I_{CC} = < 10 μA
- In Compliance with the Requirements Defined by JEDEC Standard No. 7A
- NLV Prefix for Automotive and Other Applications Requiring Unique Site and Control Change Requirements; AEC-Q100 Qualified and PPAP Capable
- These are Pb-Free Devices

Typical Applications

- Serial-to-Parallel Conversion
- Remote Control Storage Register



ON Semiconductor®

www.onsemi.com

MARKING DIAGRAMS

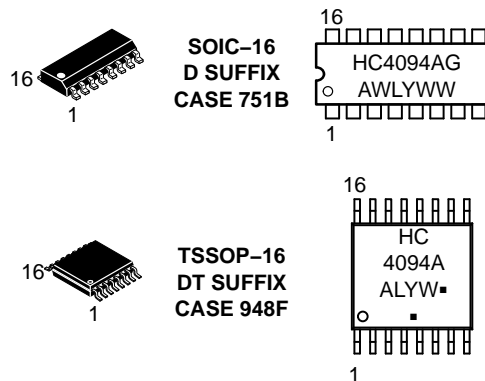

A = Assembly Location
WL, L = Wafer Lot
YY, Y = Year
WW, W = Work Week
G, ■ = Pb-Free Package

(Note: Microdot may be in either location)

ORDERING INFORMATION

See detailed ordering and shipping information in the package dimensions section on page 10 of this data sheet.

MC74HC4094A

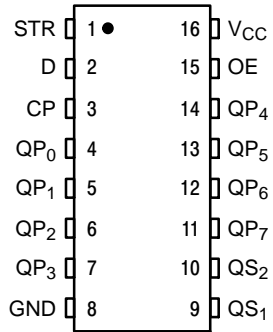

Figure 1. Pin Assignment

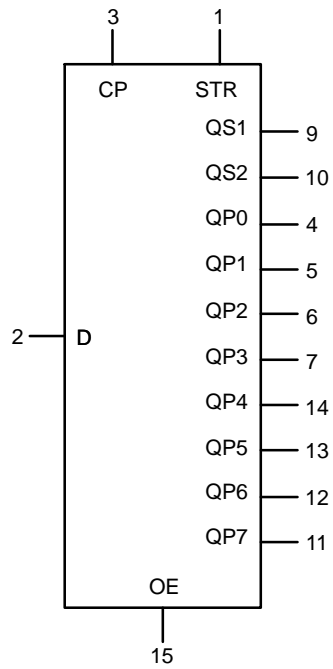

Figure 2. Logic Symbol

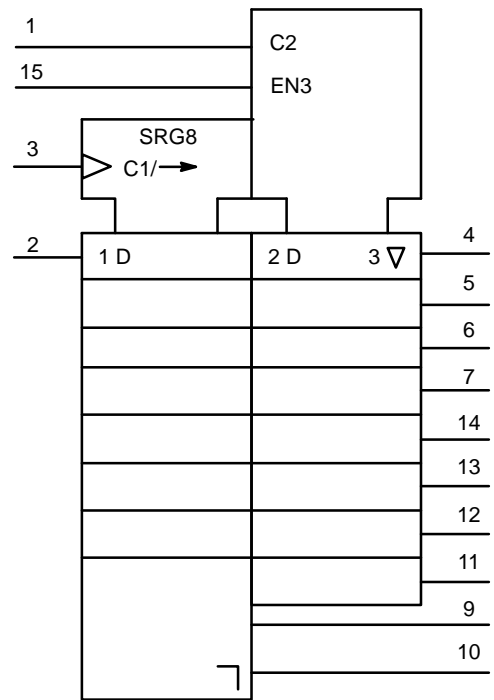

Figure 3. IEC Logic Symbol

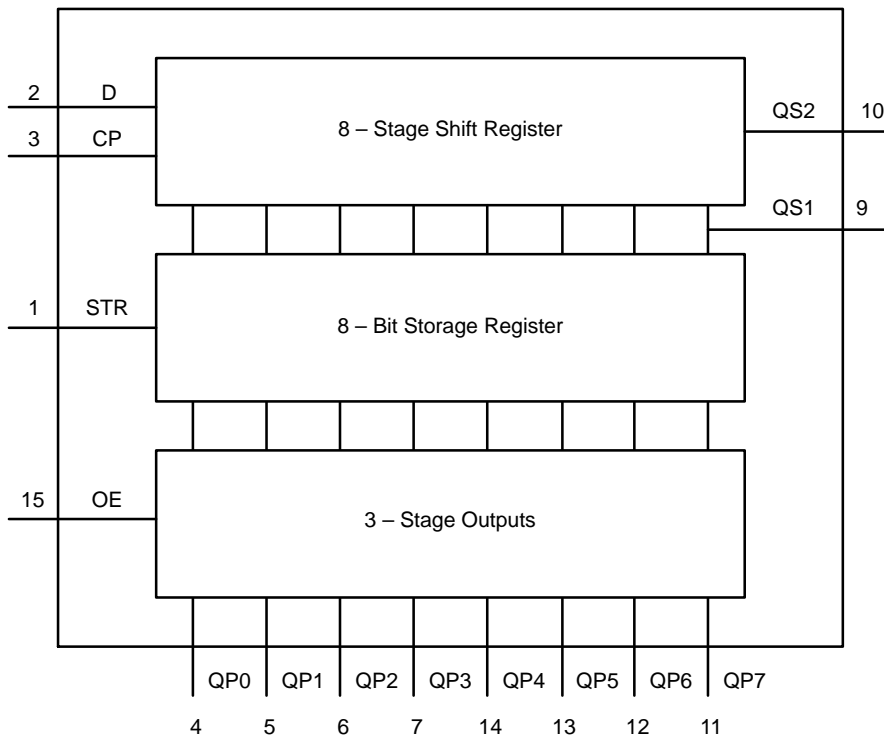

Figure 4. Functional Diagram

MC74HC4094A

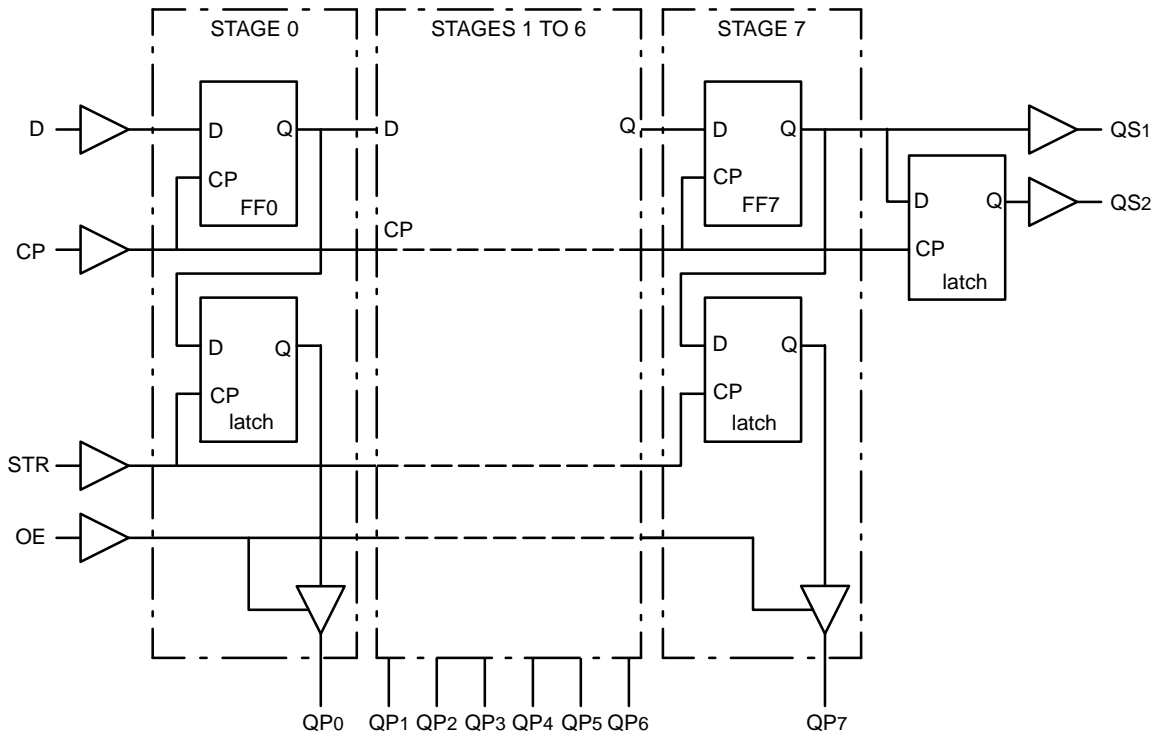

Figure 5. Logic Diagram

MC74HC4094A

MAXIMUM RATINGS

Symbol	Parameter	Value	Unit
V_{CC}	DC Supply Voltage (Referenced to GND)	- 0.5 to + 7.0	V
V_{in}	DC Input Voltage (Referenced to GND)	- 0.5 to $V_{CC} + 0.5$	V
V_{out}	DC Output Voltage (Referenced to GND)	- 0.5 to $V_{CC} + 0.5$	V
I_{in}	DC Input Current, per Pin	± 20	mA
I_{out}	DC Output Current, per Pin	± 35	mA
I_{CC}	DC Supply Current, V_{CC} and GND Pins	± 75	mA
P_D	Power Dissipation in Still Air, SOIC Package† TSSOP Package†	500 450	mW
T_{stg}	Storage Temperature	- 65 to + 150	°C

This device contains protection circuitry to guard against damage due to high static voltages or electric fields. However, precautions must be taken to avoid applications of any voltage higher than maximum rated voltages to this high-impedance circuit. For proper operation, V_{in} and V_{out} should be constrained to the range $GND \leq (V_{in} \text{ or } V_{out}) \leq V_{CC}$. Unused inputs must always be tied to an appropriate logic voltage level (e.g., either GND or V_{CC}). Unused outputs must be left open.

Stresses exceeding those listed in the Maximum Ratings table may damage the device. If any of these limits are exceeded, device functionality should not be assumed, damage may occur and reliability may be affected.

†Derating – SOIC Package: - 7 mW/°C from 65° to 125°C
TSSOP Package: - 6.1 mW/°C from 65° to 125°C

RECOMMENDED OPERATING CONDITIONS

Symbol	Parameter	Min	Max	Unit
V_{CC}	DC Supply Voltage (Referenced to GND)	2.0	6.0	V
V_{in}, V_{out}	DC Input Voltage, Output Voltage (Referenced to GND)	0	V_{CC}	V
T_A	Operating Temperature, All Package Types	-55	+125	°C
t_r, t_f	Input Rise and Fall Time (Figure 1)			ns
	$V_{CC} = 2.0\text{ V}$	0	1000	
	$V_{CC} = 4.5\text{ V}$	0	500	
	$V_{CC} = 6.0\text{ V}$	0	400	

MC74HC4094A

FUNCTIONAL TABLE

INPUTS				PARALLEL OUTPUTS		SERIAL OUTPUTS	
CP	OE	STR	D	QP0	QPn	QS1	QS2
↑	L	X	X	Z	Z	Q'6	NC
↓	L	X	X	Z	Z	NC	QP7
↑	H	L	X	NC	NC	Q'6	NC
↑	H	H	L	L	QPn-1	Q'6	NC
↑	H	H	H	H	QPn-1	Q'6	NC
↓	H	H	H	NC	NC	NC	QP7

Notes

- H = HIGH voltage level
 L = LOW voltage level
 X = don't care
 Z = high impedance OFF-state
 NC = no change
 ↑ = LOW-to-HIGH CP transition
 ↓ = HIGH-to-LOW CP transition
 Q'6 = the information in the seventh register stage is transferred to the 8th register stage and QSn output at the positive clock edge

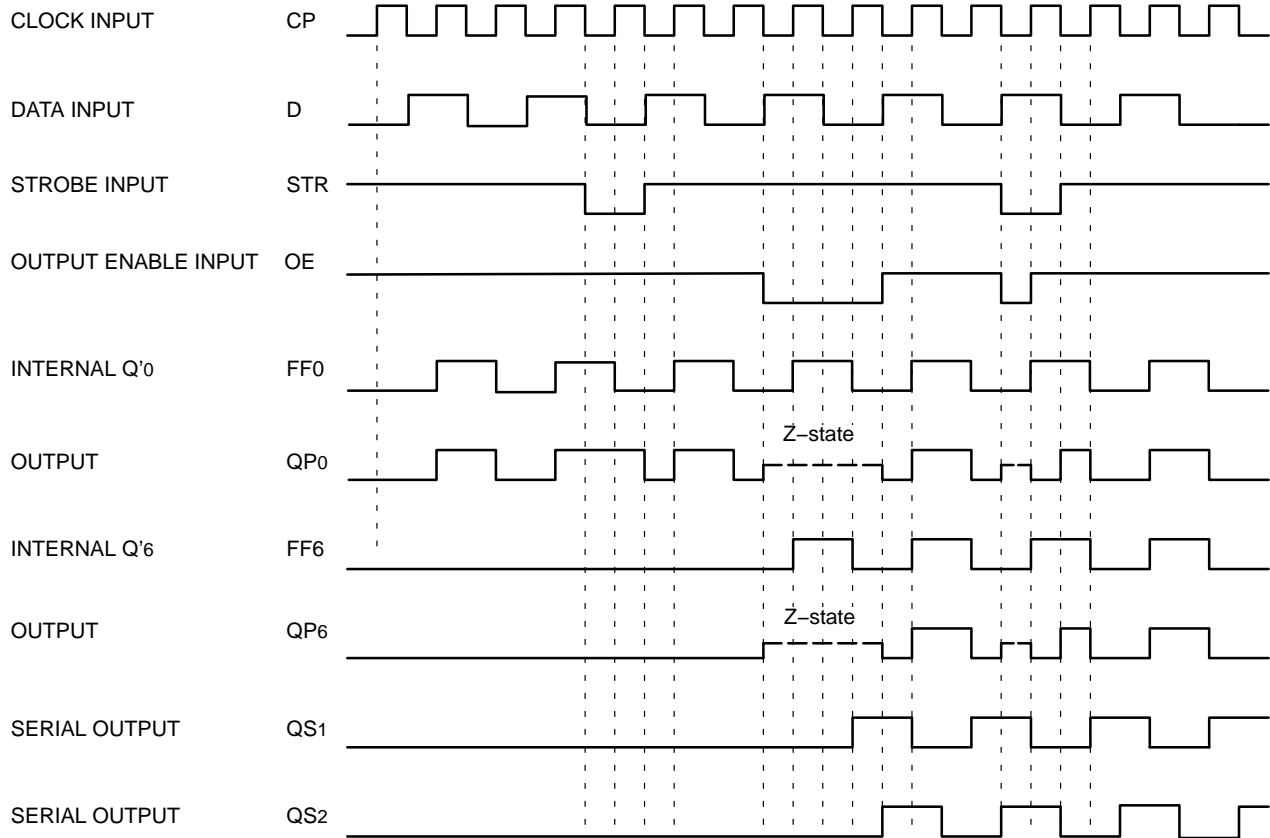

Figure 6. Timing Diagram

MC74HC4094A

DC CHARACTERISTICS

Symbol	Parameter	Test Conditions	V _{CC} (V)	Guaranteed Limits			Unit	
				-55°C to 25°C	≤ 85°C	≤ 125°C		
V _{IH}	Minimum High-Level Input Voltage	V _{OUT} = 0.1 V or V _{CC} - 0.1 V I _{OUT} ≤ 20 μA	2.0	1.5	1.5	1.5	V	
			3.0	2.1	2.1	2.1		
			4.5	3.15	3.15	3.15		
			6.0	4.2	4.2	4.2		
V _{IL}	Maximum Low-Level Input Voltage	V _{OUT} = 0.1 V or V _{CC} - 0.1 V I _{OUT} ≤ 20 μA	2.0	0.5	0.5	0.5	V	
			3.0	0.9	0.9	0.9		
			4.5	1.35	1.35	1.35		
			6.0	1.8	1.8	1.8		
V _{OH}	Minimum High-Level Output Voltage	V _{IN} = V _{IH} or V _{IL} I _{OUT} ≤ 20 μA	2.0	1.9	1.9	1.9	V	
			3.0	2.9	2.9	2.9		
			4.5	4.4	4.4	4.4		
			6.0	5.9	5.9	5.9		
			V _{IN} = V _{IH} or V _{IL} , I _{OUT} = 2.4 mA	3.0	2.75	2.7		2.6
			V _{IN} = V _{IH} or V _{IL} , I _{OUT} = 4 mA	4.5	4.25	4.2		4.1
			V _{IN} = V _{IH} or V _{IL} , I _{OUT} = 5.2 mA	6.0	5.75	5.7		5.6
V _{OL}	Maximum Low-Level Output Voltage	V _{IN} = V _{IH} or V _{IL} , I _{OUT} ≤ 20 μA	2.0	0.1	0.1	0.1	V	
			3.0	0.1	0.1	0.1		
			4.5	0.1	0.1	0.1		
			6.0	0.1	0.1	0.1		
			V _{IN} = V _{IH} or V _{IL} , I _{OUT} = 2.4 mA	3.0	0.25	0.3		0.4
			V _{IN} = V _{IH} or V _{IL} , I _{OUT} = 4 mA	4.5	0.25	0.3		0.4
			V _{IN} = V _{IH} or V _{IL} , I _{OUT} = 5.2 mA	6.0	0.25	0.3		0.4
I _{IN}	Maximum Input Leakage Current	V _{IN} = V _{CC} or GND	6.0	±0.1	±1	±1	μA	
I _{OZ}	Maximum Tri-State Output Leakage Current	V _{IN} = V _{CC} or GND V _{OUT} = V _{CC} or GND	6.0	±0.5	±5	±10	μA	
I _{CC}	Maximum Quiescent Supply Current	V _{IN} = V _{CC} or GND	6.0	4.0	40	80	μA	

MC74HC4094A

AC CHARACTERISTICS ($t_f = t_r = 6 \text{ ns}$, $C_L = 50 \text{ pF}$)

Symbol	Parameter	Test Conditions	V _{CC} (V)	Guaranteed Limits			Unit
				-55°C to 25°C	≤ 85°C	≤ 125°C	
t _{PHL} , t _{PLH}	Maximum Propagation Delay CP to QS ₁	Figure 7	2.0	120	150	170	ns
			3.0	90	100	110	
			4.5	30	38	45	
			6.0	26	33	38	
t _{PHL} , t _{PLH}	Maximum Propagation Delay CP to QS ₂	Figure 7	2.0	120	150	170	ns
			3.0	90	100	110	
			4.5	27	34	41	
			6.0	23	29	35	
t _{PHL} , t _{PLH}	Maximum Propagation Delay CP to QP _n	Figure 7	2.0	120	150	170	ns
			3.0	90	100	110	
			4.5	39	49	59	
			6.0	33	42	50	
t _{PHL} , t _{PLH}	Maximum Propagation Delay STR to QP _n	Figure 8	2.0	120	150	170	ns
			3.0	90	100	110	
			4.5	36	45	54	
			6.0	31	38	46	
t _{PZH} , t _{PZL}	Maximum 3-State Output Enable Time OE to QP _n	Figure 9	2.0	120	140	160	ns
			3.0	80	100	120	
			4.5	35	44	53	
			6.0	30	37	45	
t _{PHZ} , t _{PLZ}	Maximum 3-State Output Enable Time OE to QP _n	Figure 9	2.0	100	120	140	ns
			3.0	70	90	110	
			4.5	25	31	38	
			6.0	21	26	32	
t _{THL} , t _{TLH}	Maximum Output Transition Time	Figure 7	2.0	70	90	110	ns
			3.0	40	60	80	
			4.5	18	22	25	
			6.0	16	19	22	
t _w	Minimum Clock Pulse Width High or Low	Figure 7	2.0	80	100	120	ns
			3.0	50	60	80	
			4.5	16	20	24	
			6.0	14	17	20	
t _w	Minimum Strobe Pulse Width High	Figure 8	2.0	80	100	120	ns
			3.0	50	60	80	
			4.5	16	20	24	
			6.0	14	17	20	
t _{SU}	Minimum Set-up Time D to CP	Figure 10	2.0	50	65	75	ns
			3.0	30	35	45	
			4.5	10	13	15	
			6.0	9	11	13	

MC74HC4094A

AC CHARACTERISTICS ($t_f = t_r = 6 \text{ ns}$, $C_L = 50 \text{ pF}$)

Symbol	Parameter	Test Conditions	V _{CC} (V)	Guaranteed Limits			Unit
				-55°C to 25°C	≤ 85°C	≤ 125°C	
t _{SU}	Minimum Set-up Time CP to STR	Figure 8	2.0	100	125	150	ns
			3.0	60	75	90	
			4.5	20	25	30	
			6.0	17	21	26	
t _h	Minimum Hold Time D to CP	Figure 10	2.0	3	3	3	ns
			3.0	3	3	3	
			4.5	3	3	3	
			6.0	3	3	3	
t _h	Minimum Hold Time CP to STR	Figure 8	2.0	0	0	0	ns
			3.0	0	0	0	
			4.5	0	0	0	
			6.0	0	0	0	
f _{MAX}	Minimum Clock Pulse Frequency	Figure 7	2.0	6	5	4	MHz
			3.0	18	14	12	
			4.5	30	24	20	
			6.0	35	28	24	
C _{in}	Maximum Input Capacitance		-	10	10	10	pF
C _{out}	Maximum Output Capacitance		-	15	15	15	pF
C _{PD}	Power Dissipation Capacitance (Note 2)		-	140	140	140	pF

2. C_{PD} is defined as the value of the IC's equivalent capacitance from which the operating current can be calculated from:
 $I_{CC(\text{operating})} \approx C_{PD} \times V_{CC} \times f_{IN} \times N_{SW}$ where N_{SW} = total number of outputs switching and f_{IN} = switching frequency.

MC74HC4094A

AC WAVEFORMS

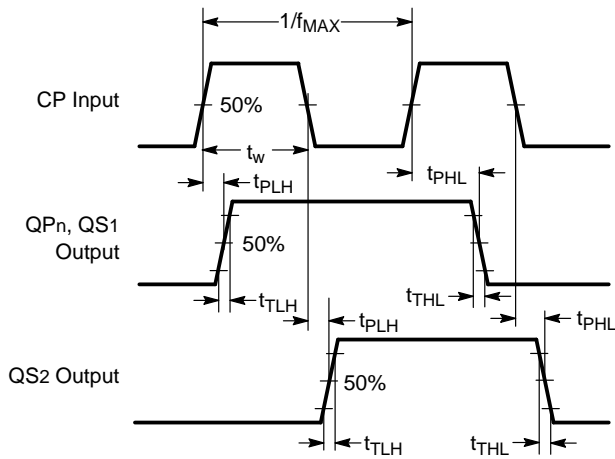

Figure 7. Waveforms showing the clock (CP) to output (QPn, QS1, QS2) propagation delays, the clock pulse width and the maximum clock frequency.

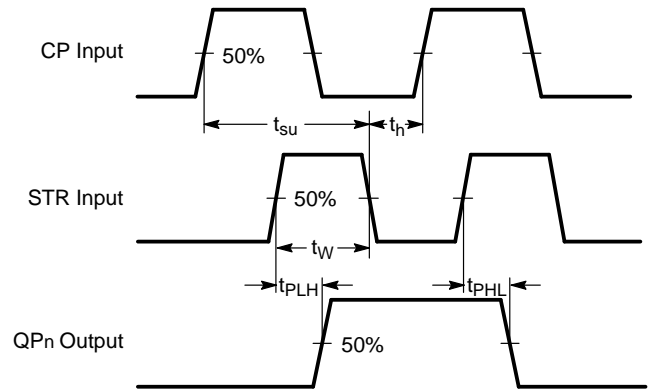

Figure 8. Waveforms showing the strobe (STR) to output (QPn) propagation delays, the strobe pulse width, the clock set-up and hold times for the strobe input.

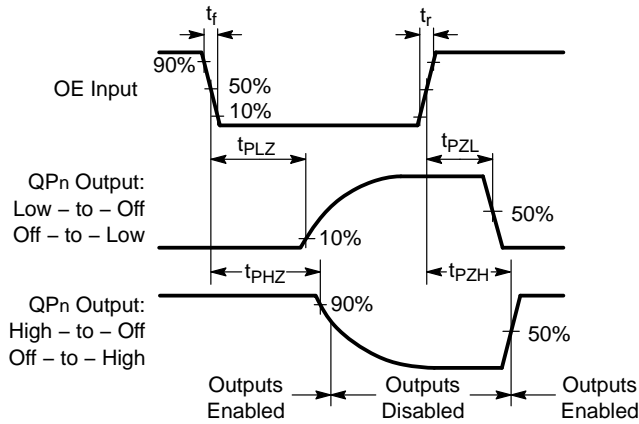
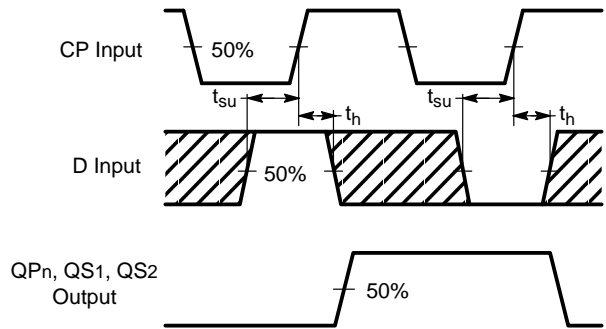

Figure 9. Waveforms showing the 3-state enable and disable times for input OE.



The shaded areas indicate when the input is permitted to change for predictable output performance.

Figure 10. Waveforms showing the data set-up and hold times for the data input.

MC74HC4094A

TEST CIRCUITS

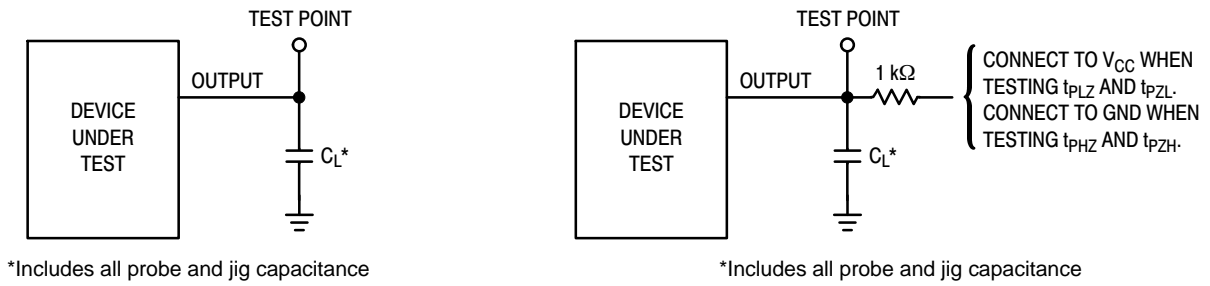

Figure 11. AC Characteristics Load Circuits

ORDERING INFORMATION

Device	Package	Shipping†
MC74HC4094ADG	SOIC-16 (Pb-Free)	48 Units / Rail
MC74HC4094ADR2G	SOIC-16 (Pb-Free)	2500 / Tape & Reel
MC74HC4094ADTG	TSSOP-16 (Pb-Free)	96 Units / Rail
MC74HC4094ADTR2G	TSSOP-16 (Pb-Free)	2500 / Tape & Reel
NLVHC4094BDTR2G*	TSSOP-16 (Pb-Free)	2500 / Tape & Reel

†For information on tape and reel specifications, including part orientation and tape sizes, please refer to our Tape and Reel Packaging Specifications Brochure, BRD8011/D.

*NLV Prefix for Automotive and Other Applications Requiring Unique Site and Control Change Requirements; AEC-Q100 Qualified and PPAP Capable.

MC74HC4094A

PACKAGE DIMENSIONS

TSSOP-16
DT SUFFIX
CASE 948F
ISSUE B

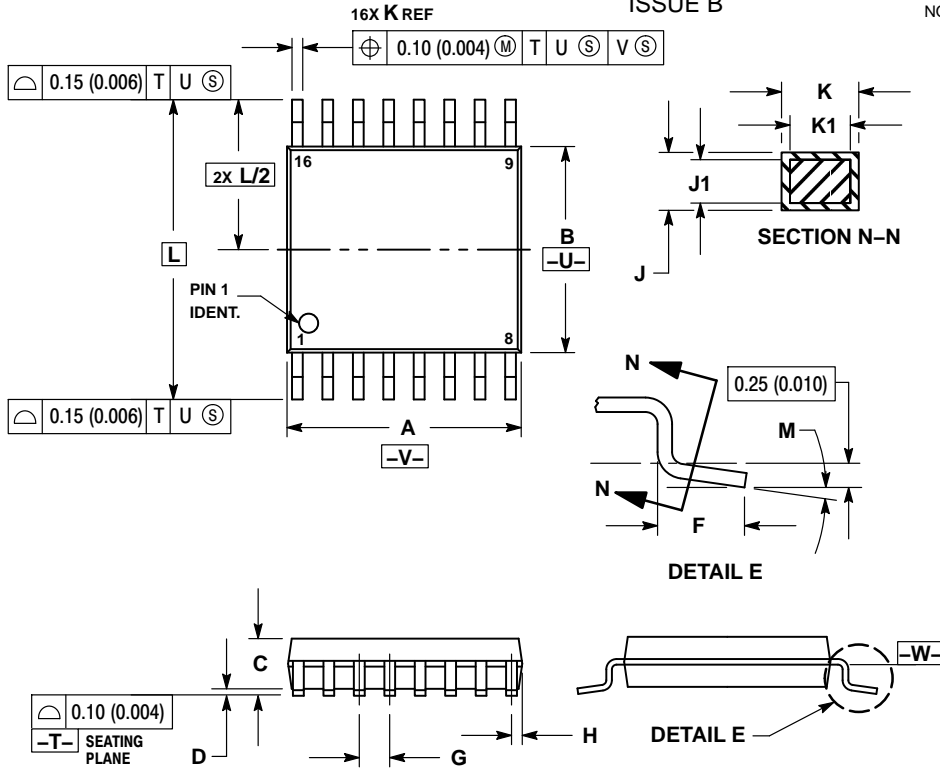

NOTES:

1. DIMENSIONING AND TOLERANCING PER ANSI Y14.5M, 1982.
2. CONTROLLING DIMENSION: MILLIMETER.
3. DIMENSION A DOES NOT INCLUDE MOLD FLASH, PROTRUSIONS OR GATE BURRS. MOLD FLASH OR GATE BURRS SHALL NOT EXCEED 0.15 (0.006) PER SIDE.
4. DIMENSION B DOES NOT INCLUDE INTERLEAD FLASH OR PROTRUSION. INTERLEAD FLASH OR PROTRUSION SHALL NOT EXCEED 0.25 (0.010) PER SIDE.
5. DIMENSION K DOES NOT INCLUDE DAMBAR PROTRUSION. ALLOWABLE DAMBAR PROTRUSION SHALL BE 0.08 (0.003) TOTAL IN EXCESS OF THE K DIMENSION AT MAXIMUM MATERIAL CONDITION.
6. TERMINAL NUMBERS ARE SHOWN FOR REFERENCE ONLY.
7. DIMENSION A AND B ARE TO BE DETERMINED AT DATUM PLANE -W-.

DIM	MILLIMETERS		INCHES	
	MIN	MAX	MIN	MAX
A	4.90	5.10	0.193	0.200
B	4.30	4.50	0.169	0.177
C	---	1.20	---	0.047
D	0.05	0.15	0.002	0.006
F	0.50	0.75	0.020	0.030
G	0.65 BSC		0.026 BSC	
H	0.18	0.28	0.007	0.011
J	0.09	0.20	0.004	0.008
J1	0.09	0.16	0.004	0.006
K	0.19	0.30	0.007	0.012
K1	0.19	0.25	0.007	0.010
L	6.40 BSC		0.252 BSC	
M	0°	8°	0°	8°

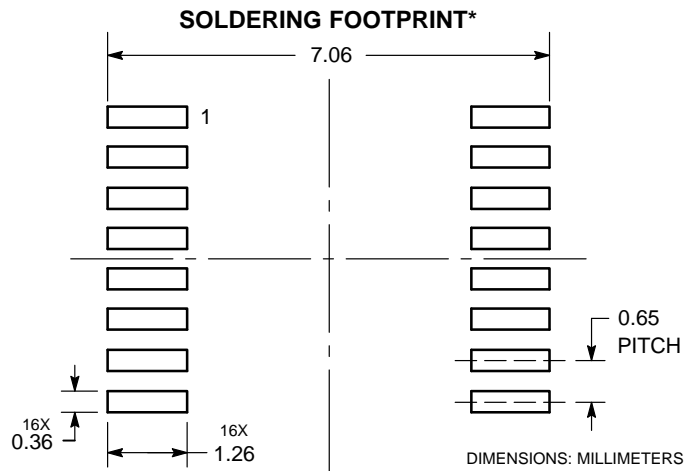

*For additional information on our Pb-Free strategy and soldering details, please download the ON Semiconductor Soldering and Mounting Techniques Reference Manual, SOLDERRM/D.

MC74HC4094A

PACKAGE DIMENSIONS

SOIC-16
CASE 751B-05
ISSUE K

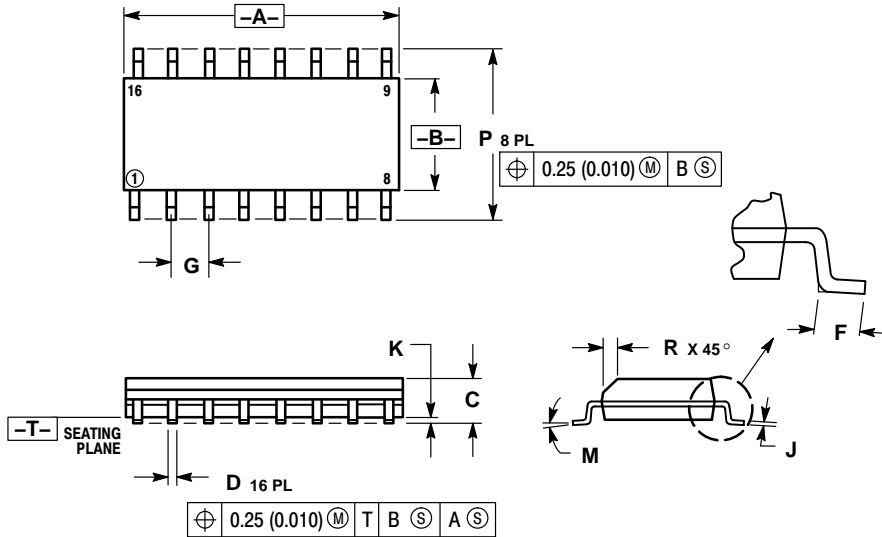

NOTES:

1. DIMENSIONING AND TOLERANCING PER ANSI Y14.5M, 1982.
2. CONTROLLING DIMENSION: MILLIMETER.
3. DIMENSIONS A AND B DO NOT INCLUDE MOLD PROTRUSION.
4. MAXIMUM MOLD PROTRUSION 0.15 (0.006) PER SIDE.
5. DIMENSION D DOES NOT INCLUDE DAMBAR PROTRUSION. ALLOWABLE DAMBAR PROTRUSION SHALL BE 0.127 (0.005) TOTAL IN EXCESS OF THE D DIMENSION AT MAXIMUM MATERIAL CONDITION.

MILLIMETERS		INCHES		
DIM	MIN	MAX	MIN	MAX
A	9.80	10.00	0.386	0.393
B	3.80	4.00	0.150	0.157
C	1.35	1.75	0.054	0.068
D	0.35	0.49	0.014	0.019
F	0.40	1.25	0.016	0.049
G	1.27 BSC		0.050 BSC	
J	0.19	0.25	0.008	0.009
K	0.10	0.25	0.004	0.009
M	0°	7°	0°	7°
P	5.80	6.20	0.229	0.244
R	0.25	0.50	0.010	0.019

SOLDERING FOOTPRINT*

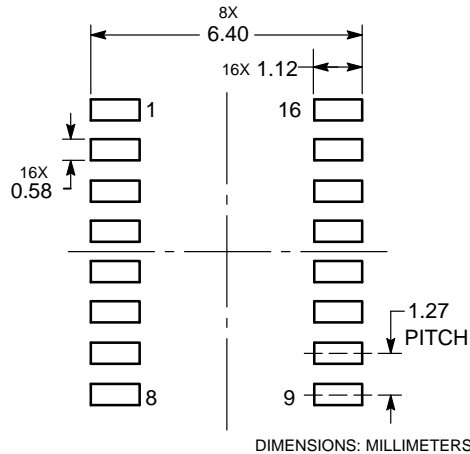

*For additional information on our Pb-Free strategy and soldering details, please download the ON Semiconductor Soldering and Mounting Techniques Reference Manual, SOLDERRM/D.

ON Semiconductor and are registered trademarks of Semiconductor Components Industries, LLC (SCILLC). SCILLC owns the rights to a number of patents, trademarks, copyrights, trade secrets, and other intellectual property. A listing of SCILLC's product/patent coverage may be accessed at www.onsemi.com/site/pdf/Patent-Marking.pdf. SCILLC reserves the right to make changes without further notice to any products herein. SCILLC makes no warranty, representation or guarantee regarding the suitability of its products for any particular purpose, nor does SCILLC assume any liability arising out of the application or use of any product or circuit, and specifically disclaims any and all liability, including without limitation special, consequential or incidental damages. "Typical" parameters which may be provided in SCILLC data sheets and/or specifications can and do vary in different applications and actual performance may vary over time. All operating parameters, including "Typicals" must be validated for each customer application by customer's technical experts. SCILLC does not convey any license under its patent rights nor the rights of others. SCILLC products are not designed, intended, or authorized for use as components in systems intended for surgical implant into the body, or other applications intended to support or sustain life, or for any other application in which the failure of the SCILLC product could create a situation where personal injury or death may occur. Should Buyer purchase or use SCILLC products for any such unintended or unauthorized application, Buyer shall indemnify and hold SCILLC and its officers, employees, subsidiaries, affiliates, and distributors harmless against all claims, costs, damages, and expenses, and reasonable attorney fees arising out of, directly or indirectly, any claim of personal injury or death associated with such unintended or unauthorized use, even if such claim alleges that SCILLC was negligent regarding the design or manufacture of the part. SCILLC is an Equal Opportunity/Affirmative Action Employer. This literature is subject to all applicable copyright laws and is not for resale in any manner.

PUBLICATION ORDERING INFORMATION

LITERATURE FULFILLMENT:
Literature Distribution Center for ON Semiconductor
P.O. Box 5163, Denver, Colorado 80217 USA
Phone: 303-675-2175 or 800-344-3860 Toll Free USA/Canada
Fax: 303-675-2176 or 800-344-3867 Toll Free USA/Canada
Email: orderlit@onsemi.com

N. American Technical Support: 800-282-9855 Toll Free
USA/Canada
Europe, Middle East and Africa Technical Support:
Phone: 421 33 790 2910
Japan Customer Focus Center
Phone: 81-3-5817-1050

ON Semiconductor Website: www.onsemi.com
Order Literature: <http://www.onsemi.com/orderlit>

For additional information, please contact your local Sales Representative

Looking for pricing, stock, or lifecycle information?

Click below to explore more details on WIN SOURCE:

- ⊖ [View MC74HC4094ADR2G on WIN SOURCE](#)
- ⊖ [ON Semiconductor Information](#)

Optimize Your Supply Chain with WIN SOURCE Solutions

- ✓ Global Sourcing Solution
- ✓ Obsolete Management
- ✓ Cost Control Management
- ✓ Shortage Management
- ✓ Alternative Solution
- ✓ Excess Inventory Management