



**THE DATASHEET OF  
MC74AC4040DG**



# MC74AC4040

## 12-Stage Binary Ripple Counter

The MC74AC4040 consists of 12 master-slave flip-flops. The output of each flip-flop feeds the next and the frequency at each output is half that of the preceding one. The state of the counter advances on the negative-going edge of the Clock input. Reset is asynchronous and active-high.

State changes of the Q outputs do not occur simultaneously because of internal ripple delays. Therefore, decoded output signals are subject to decoding spikes and may have to be gated with the Clock of the MC74AC4040 for some designs.

### Features

- 140 MHz Typ. Clock
- Outputs Source/Sink 24 mA
- Operating Voltage Range: 2.0 to 6.0 V
- High Noise Immunity
- These are Pb-Free Devices

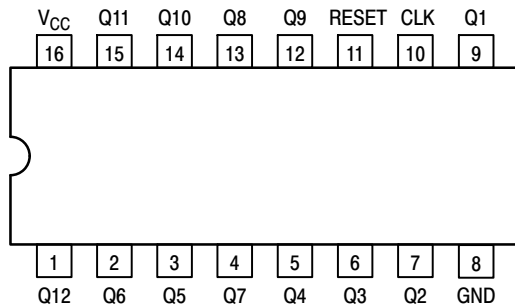

Figure 1. Pinout: 16-Lead Packages Conductors (Top View)

### FUNCTION TABLE

Clock	Reset	Output State
	L	No Change
	L	Advance to next state
X	H	All Outputs are low



ON Semiconductor®

[www.onsemi.com](http://www.onsemi.com)

### MARKING DIAGRAM

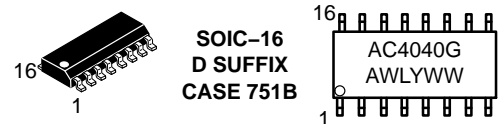

- A = Assembly Location
- WL = Wafer Lot
- Y = Year
- WW = Work Week
- G = Pb-Free Package

### ORDERING INFORMATION

See detailed ordering and shipping information in the package dimensions section on page 5 of this data sheet.

# MC74AC4040

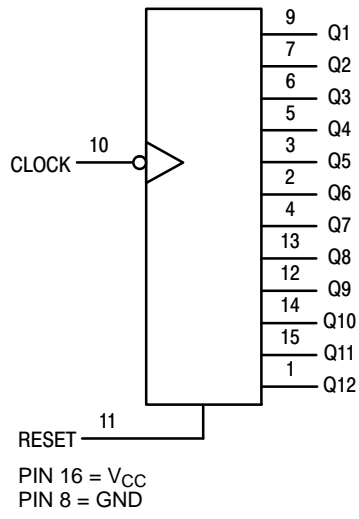

Figure 2. Logic Diagram

# MC74AC4040

## MAXIMUM RATINGS

Symbol	Parameter	Value	Unit	
V <sub>CC</sub>	DC Supply Voltage	-0.5 to +7.0	V	
V <sub>I</sub>	DC Input Voltage	-0.5 ≤ V <sub>CC</sub> +0.5	V	
V <sub>O</sub>	DC Output Voltage (Note 1)	-0.5 ≤ V <sub>CC</sub> +0.5	V	
I <sub>IK</sub>	DC Input Diode Current	±20	mA	
I <sub>OK</sub>	DC Output Diode Current	±50	mA	
I <sub>O</sub>	DC Output Sink/Source Current	±50	mA	
I <sub>CC</sub>	DC Supply Current per Output Pin	±50	mA	
I <sub>GND</sub>	DC Ground Current per Output Pin	±50	mA	
T <sub>STG</sub>	Storage Temperature Range	-65 to +150	°C	
T <sub>L</sub>	Lead temperature, 1 mm from Case for 10 Seconds	260	°C	
T <sub>J</sub>	Junction temperature under Bias	+150	°C	
θ <sub>JA</sub>	Thermal Resistance (Note 2)	69.1	°C/W	
P <sub>D</sub>	Power Dissipation in Still Air at 65°C (Note 3)	500	mW	
MSL	Moisture Sensitivity	Level 1		
F <sub>R</sub>	Flammability Rating	Oxygen Index: 30% – 35% UL 94 V-0 @ 0.125 in		
V <sub>ESD</sub>	ESD Withstand Voltage	Human Body Model (Note 4) Machine Model (Note 5) Charged Device Model (Note 6)	> 2000 > 200 > 1000	V
I <sub>Latch-Up</sub>	Latch-Up Performance	Above V <sub>CC</sub> and Below GND at 85°C (Note 7)	±100	mA

Stresses exceeding those listed in the Maximum Ratings table may damage the device. If any of these limits are exceeded, device functionality should not be assumed, damage may occur and reliability may be affected.

1. I<sub>O</sub> absolute maximum rating must be observed.
2. The package thermal impedance is calculated in accordance with JESD51-7.
3. 500 mW at 65°C; derate to 300 mW by 10 mW/ from 65°C to 85°C.
4. Tested to EIA/JESD22-A114-A.
5. Tested to EIA/JESD22-A115-A.
6. Tested to JESD22-C101-A.
7. Tested to EIA/JESD78.

## RECOMMENDED OPERATING CONDITIONS

Symbol	Parameter	Min	Max	Unit
V <sub>CC</sub>	DC Supply Voltage (Referenced to GND)	2.0	6.0	V
V <sub>IN</sub> /V <sub>OUT</sub>	Input Voltage, Output Voltage (Referenced to GND)	0	V <sub>CC</sub>	-
T <sub>A</sub>	Operating Temperature, All Package Types	-40	+85	°C
t <sub>r</sub> /t <sub>f</sub>	Input Rise/Fall Time (Figure 1)			ns/V
	V <sub>CC</sub> = 3.0 V	0	150	
	V <sub>CC</sub> = 4.5 V	0	40	
	V <sub>CC</sub> = 5.5 V	0	25	

Functional operation above the stresses listed in the Recommended Operating Ranges is not implied. Extended exposure to stresses beyond the Recommended Operating Ranges limits may affect device reliability.

# MC74AC4040

## DC CHARACTERISTICS (unless otherwise specified)

Symbol	Parameter	Value	Unit	
$I_{CC}$	Maximum Quiescent Supply Voltage	80	$\mu A$	$V_{in} = V_{CC}$ or GND $V_{CC} = 5.5 V, T_A = \text{Worst Case}$
$I_{CC}$	Maximum Quiescent Supply Current	8.0	$\mu A$	$V_{in} = V_{CC}$ or GND $V_{CC} = 5.5 V, T_A = 25^\circ C$

## DC CHARACTERISTICS

Symbol	Parameter	$V_{CC}$ (V)	74AC		74AC		Unit	Conditions
			$T_A = +25^\circ C$		$T_A = -40^\circ C$ to $+85^\circ C$			
			Typ	Guaranteed Limits				
$V_{IH}$	Minimum High Level Input Voltage	3.0	–	2.1	2.1		V	$V_{OUT} = 0.1 V$ or $V_{CC} - 0.1 V$
		4.5	–	3.15	3.15			
		5.5	–	3.85	3.85			
$V_{IL}$	Maximum Low Level Input Voltage	3.0	–	0.9	0.9		V	$V_{OUT} = 0.1 V$ or $V_{CC} - 0.1 V$
		4.5	–	1.35	1.35			
		5.5	–	1.65	1.65			
$V_{OH}$	Minimum High Level Output Voltage	3.0	2.99	2.9	2.9		V	$I_{OUT} = -50 \mu A$
		4.5	4.49	4.4	4.4			
		5.5	5.49	5.4	5.4			
		3.0	–	2.56	2.46		V	* $V_{IN} = V_{IL}$ or $V_{IH}$ –12 mA $I_{OH}$ –24 mA –24 mA
		4.5	–	3.86	3.76			
		5.5	–	4.86	4.76			
$V_{OL}$	Maximum Low Level Output Voltage	3.0	0.002	0.1	0.1		V	$I_{OUT} = 50 \mu A$
		4.5	0.001	0.1	0.1			
		5.5	0.001	0.1	0.1			
		3.0	–	0.36	0.44		V	* $V_{IN} = V_{IL}$ or $V_{IH}$ 12 mA $I_{OL}$ 24 mA 24 mA
		4.5	–	0.36	0.44			
		5.5	–	0.36	0.44			
$I_{IN}$	Maximum Input Leakage Current	5.5	–	$\pm 0.1$	$\pm 1.0$		$\mu A$	$V_I = V_{CC}, GND$
$I_{OLD}$	Minimum Dynamic Output Current†	5.5	–	–	75		mA	$V_{OLD} = 1.65 V \text{ Max}$
$I_{OHD}$		5.5	–	–	–75		mA	$V_{OHD} = 3.85 V \text{ Min}$

\*All outputs loaded; thresholds on input associated with output under test.

†Maximum test duration 2.0 ms, one output loaded at a time.

# MC74AC4040

**AC CHARACTERISTICS** (For Figures and Waveforms – See Section 3 of the ON Semiconductor FACT Data Book, DL138/D)

Symbol	Parameter	V <sub>CC</sub> * (V)	74AC			74AC		Unit	Fig. No.
			T <sub>A</sub> = +25°C C <sub>L</sub> = 50 pF			T <sub>A</sub> = -40°C to +85°C C <sub>L</sub> = 50 pF			
			Min	Typ	Max	Min	Max		
f <sub>max</sub>	Maximum Clock Frequency	3.3 5.0	110 130	120 140	– –	100 120	– –	MHz	–
n <sub>CP</sub> to Q1	Propagation Delay n <sub>CP</sub> to Q1	3.3 5.0	2.0 2.0	– –	11 8.0	2.0 2.0	14 10	ns	–
Q <sub>n</sub> to Q <sub>n+1</sub>	Propagation Delay Q <sub>n</sub> to Q <sub>n+1</sub>	3.3 5.0	0 0	– –	5.5 3.5	0 0	6.5 4.5	ns	–
MR to Q t <sub>HL</sub>	Propagation Delay MR to Q	3.3 5.0	3.0 3.0	– –	12 10	3.0 3.0	15 12	ns	–
t <sub>rec</sub> n <sub>CP</sub> to MR	Recovery Time	3.3 5.0	0 0	–2.5 –1.5	– –	0 0	– –	ns	–
t <sub>w</sub> n <sub>CP</sub>	Minimum Pulse Width Clock Pin	3.3 5.0	4.0 3.0	3.5 2.5	– –	4.5 3.5	– –	ns	–
t <sub>w</sub> MR	Minimum Pulse Width Master Reset	3.3 3.0	4.0 3.0	3.5 2.5	– –	4.5 3.5	– –	ns	–

\*Voltage Range 3.3 V is 3.3 V ±0.3 V.

\*Voltage Range 5.0 V is 5.0 V ±0.5 V.

## CAPACITANCE

Symbol	Parameter	Value Typ	Unit	Test Conditions
C <sub>IN</sub>	Input Capacitance	4.5	pF	V <sub>CC</sub> = 5.0 V
C <sub>PD</sub>	Power Dissipation Capacitance	50	pF	V <sub>CC</sub> = 5.0 V

## ORDERING INFORMATION

Part Number	Package	Shipping†
MC74AC4040DG	SOIC-16 (Pb-Free)	48 Units / Rail
MC74AC4040DR2G	SOIC-16 (Pb-Free)	2500 / Tape & Reel

†For information on tape and reel specifications, including part orientation and tape sizes, please refer to our Tape and Reel Packaging Specifications Brochure, BRD8011/D.

# MC74AC4040

## PACKAGE DIMENSIONS

SOIC-16  
D SUFFIX  
CASE 751B-05  
ISSUE K

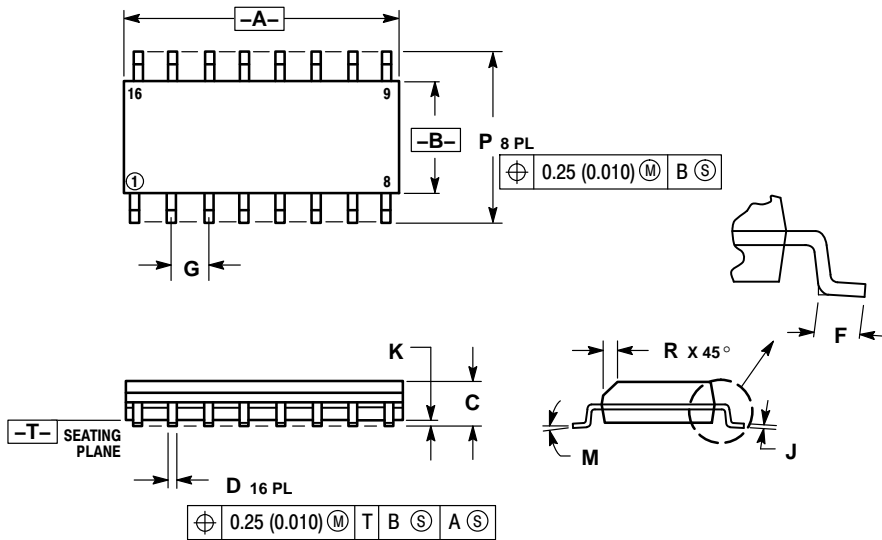

NOTES:

1. DIMENSIONING AND TOLERANCING PER ANSI Y14.5M, 1982.
2. CONTROLLING DIMENSION: MILLIMETER.
3. DIMENSIONS A AND B DO NOT INCLUDE MOLD PROTRUSION.
4. MAXIMUM MOLD PROTRUSION 0.15 (0.006) PER SIDE.
5. DIMENSION D DOES NOT INCLUDE DAMBAR PROTRUSION. ALLOWABLE DAMBAR PROTRUSION SHALL BE 0.127 (0.005) TOTAL IN EXCESS OF THE D DIMENSION AT MAXIMUM MATERIAL CONDITION.

DIM	MILLIMETERS		INCHES	
	MIN	MAX	MIN	MAX
A	9.80	10.00	0.386	0.393
B	3.80	4.00	0.150	0.157
C	1.35	1.75	0.054	0.068
D	0.35	0.49	0.014	0.019
F	0.40	1.25	0.016	0.049
G	1.27 BSC		0.050 BSC	
J	0.19	0.25	0.008	0.009
K	0.10	0.25	0.004	0.009
M	0°	7°	0°	7°
P	5.80	6.20	0.229	0.244
R	0.25	0.50	0.010	0.019

### SOLDERING FOOTPRINT\*

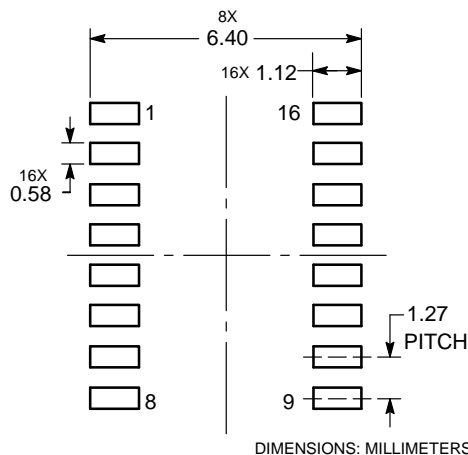

DIMENSIONS: MILLIMETERS

\*For additional information on our Pb-Free strategy and soldering details, please download the ON Semiconductor Soldering and Mounting Techniques Reference Manual, SOLDERRM/D.

ON Semiconductor and the are registered trademarks of Semiconductor Components Industries, LLC (SCILLC) or its subsidiaries in the United States and/or other countries. SCILLC owns the rights to a number of patents, trademarks, copyrights, trade secrets, and other intellectual property. A listing of SCILLC's product/patent coverage may be accessed at [www.onsemi.com/site/pdf/Patent-Marketing.pdf](http://www.onsemi.com/site/pdf/Patent-Marketing.pdf). SCILLC reserves the right to make changes without further notice to any products herein. SCILLC makes no warranty, representation or guarantee regarding the suitability of its products for any particular purpose, nor does SCILLC assume any liability arising out of the application or use of any product or circuit, and specifically disclaims any and all liability, including without limitation special, consequential or incidental damages. "Typical" parameters which may be provided in SCILLC data sheets and/or specifications can and do vary in different applications and actual performance may vary over time. All operating parameters, including "Typicals" must be validated for each customer application by customer's technical experts. SCILLC does not convey any license under its patent rights nor the rights of others. SCILLC products are not designed, intended, or authorized for use as components in systems intended for surgical implant into the body, or other applications intended to support or sustain life, or for any other application in which the failure of the SCILLC product could create a situation where personal injury or death may occur. Should Buyer purchase or use SCILLC products for any such unintended or unauthorized application, Buyer shall indemnify and hold SCILLC and its officers, employees, subsidiaries, affiliates, and distributors harmless against all claims, costs, damages, and expenses, and reasonable attorney fees arising out of, directly or indirectly, any claim of personal injury or death associated with such unintended or unauthorized use, even if such claim alleges that SCILLC was negligent regarding the design or manufacture of the part. SCILLC is an Equal Opportunity/Affirmative Action Employer. This literature is subject to all applicable copyright laws and is not for resale in any manner.

### PUBLICATION ORDERING INFORMATION

**LITERATURE FULFILLMENT:**  
Literature Distribution Center for ON Semiconductor  
P.O. Box 5163, Denver, Colorado 80217 USA  
Phone: 303-675-2175 or 800-344-3860 Toll Free USA/Canada  
Fax: 303-675-2176 or 800-344-3867 Toll Free USA/Canada  
Email: [orderlit@onsemi.com](mailto:orderlit@onsemi.com)

**N. American Technical Support:** 800-282-9855 Toll Free USA/Canada  
**Europe, Middle East and Africa Technical Support:**  
Phone: 421 33 790 2910  
**Japan Customer Focus Center**  
Phone: 81-3-5817-1050

**ON Semiconductor Website:** [www.onsemi.com](http://www.onsemi.com)  
**Order Literature:** <http://www.onsemi.com/orderlit>  
For additional information, please contact your local Sales Representative

## Looking for pricing, stock, or lifecycle information?

Click below to explore more details on WIN SOURCE:

 [View MC74AC4040DG](#) on WIN SOURCE

 [ON Semiconductor](#) Information

## Optimize Your Supply Chain with WIN SOURCE Solutions

-  Global Sourcing Solution
-  Obsolete Management
-  Cost Control Management
-  Shortage Management
-  Alternative Solution
-  Excess Inventory Management