



**THE DATASHEET OF
MC68HC908JB8ADW**



MC68HC908JB8

MC68HC08JB8

MC68HC08JT8

Technical Data

M68HC08
Microcontrollers

MC68HC908JB8/D
Rev. 2.3
9/2005

freescale.com



MC68HC908JB8

MC68HC08JB8

MC68HC08JT8

Technical Data

To provide the most up-to-date information, the revision of our documents on the World Wide Web will be the most current. Your printed copy may be an earlier revision. To verify you have the latest information available, refer to:

<http://freescale.com>

The following revision history table summarizes changes contained in this document. For your convenience, the page number designators have been linked to the appropriate location.

Freescale and the Freescale logo are registered trademarks of Freescale Semiconductor, Inc. This product incorporates SuperFlash® technology licensed from SST.

© Freescale Semiconductor, Inc., 2005. All rights reserved.

Revision History

Date	Revision Level	Description	Page Number(s)
September 2005	2.3	Added Pb-free parts.	267, 284
August 2005	2.2	Updated to meet Freescale identity guidelines.	Throughout
December 2003	2.1	4.9 ROM-Resident Routines — Removed block erase references for ROM-resident routines.	61
		9.8.8 USB Control Register 3 — Clarified bit descriptions for OSTALL0 and ISTALL0.	149, 150
		9.8.11 USB Status Register 1 — Clarified bit descriptions for TXACK, TXNAK, and TXSTL.	153
		Section 19. Mechanical Specifications — Replaced incorrect 44-pin QFP drawing, case 824E to case 824A.	263
February 2002	2	Corrected PTD6 and PTD7: not direct LED drive pins.	28, 210, 217
		Removed incorrect RX1E text from USB control register 1.	146
		Corrected Figure 9-30 for USB module.	159
		Corrected timer discrepancies throughout Section 11. Timer Interface Module (TIM) .	177
		Added Table 12-1 . Port Control Register Bits Summary .	201
		Changed pullup resistor limits for D– and I/O ports in 18.6 DC Electrical Characteristics .	256
		Added mechanical drawing for 20-pin SOIC package.	266
		Added Appendix A. MC68HC08JB8 — ROM part.	269
		Added Appendix B. MC68HC08JT8 — low-voltage ROM part.	277



List of Sections

Section 1. General Description	27
Section 2. Memory Map	39
Section 3. Random-Access Memory (RAM)	51
Section 4. FLASH Memory	53
Section 5. Configuration Register (CONFIG)	65
Section 6. Central Processor Unit (CPU)	69
Section 7. Oscillator (OSC)	89
Section 8. System Integration Module (SIM)	93
Section 9. Universal Serial Bus Module (USB).....	117
Section 10. Monitor ROM (MON)	163
Section 11. Timer Interface Module (TIM).....	177
Section 12. Input/Output Ports (I/O)	199
Section 13. External Interrupt (IRQ)	219
Section 14. Keyboard Interrupt Module (KBI).....	227
Section 15. Computer Operating Properly (COP)	237
Section 16. Low Voltage Inhibit (LVI)	243
Section 17. Break Module (BREAK)	245
Section 18. Electrical Specifications.....	253
Section 19. Mechanical Specifications	263
Section 20. Ordering Information	267
Appendix A. MC68HC08JB8.....	269
Appendix B. MC68HC08JT8	277



List of Sections

Table of Contents

Section 1. General Description

1.1	Contents	27
1.2	Introduction	27
1.3	Features	28
1.4	MCU Block Diagram	30
1.5	Pin Assignments	32
1.5.1	Power Supply Pins (V_{DD} , V_{SS})	34
1.5.2	Voltage Regulator Out (V_{REG})	34
1.5.3	Oscillator Pins (OSC1 and OSC2)	35
1.5.4	External Reset Pin (\overline{RST})	35
1.5.5	External Interrupt Pins (\overline{IRQ} , PTE4/D $-$)	35
1.5.6	Port A Input/Output (I/O) Pins (PTA7/ $\overline{KBA7}$ –PTA0/ $\overline{KBA0}$)	36
1.5.7	Port B (I/O) Pins (PTB7–PTB0)	36
1.5.8	Port C I/O Pins (PTC7–PTC0)	36
1.5.9	Port D I/O Pins (PTD7–PTD0)	36
1.5.10	Port E I/O Pins (PTE4/D $-$, PTE3/D $+$, PTE2/TCH1, PTE1/TCH0, PTE0/TCLK)	36

Section 2. Memory Map

2.1	Contents	39
2.2	Introduction	39
2.3	I/O Section	41
2.4	Monitor ROM	41

Section 3. Random-Access Memory (RAM)

3.1 Contents 51

3.2 Introduction 51

3.3 Functional Description 51

Section 4. FLASH Memory

4.1 Contents 53

4.2 Introduction 53

4.3 Functional Description 54

4.4 FLASH Control Register 55

4.5 FLASH Block Erase Operation 56

4.6 FLASH Mass Erase Operation 57

4.7 FLASH Program Operation 58

4.8 FLASH Protection 60

4.8.1 FLASH Block Protect Register 60

4.9 ROM-Resident Routines 61

4.9.1 Variables 62

4.9.2 ERASE Routine 62

4.9.3 PROGRAM Routine 63

4.9.4 VERIFY Routine 63

Section 5. Configuration Register (CONFIG)

5.1 Contents 65

5.2 Introduction 65

5.3 Functional Description 66

Section 6. Central Processor Unit (CPU)

6.1	Contents	69
6.2	Introduction	70
6.3	Features	70
6.4	CPU Registers	71
6.4.1	Accumulator	71
6.4.2	Index Register	72
6.4.3	Stack Pointer	72
6.4.4	Program Counter	73
6.4.5	Condition Code Register	74
6.5	Arithmetic/Logic Unit (ALU)	76
6.6	Low-Power Modes	76
6.6.1	Wait Mode	76
6.6.2	Stop Mode	77
6.7	CPU During Break Interrupts	77
6.8	Instruction Set Summary	78
6.9	Opcode Map	86

Section 7. Oscillator (OSC)

7.1	Contents	89
7.2	Introduction	89
7.3	Oscillator External Connections	90
7.4	I/O Signals	91
7.4.1	Crystal Amplifier Input Pin (OSC1)	91
7.4.2	Crystal Amplifier Output Pin (OSC2)	91
7.4.3	Oscillator Enable Signal (SIMOSCEN)	91
7.4.4	External Clock Source (OSCXCLK)	91
7.4.5	Oscillator Out (OSCOUT)	92
7.5	Low-Power Modes	92
7.5.1	Wait Mode	92
7.5.2	Stop Mode	92
7.6	Oscillator During Break Mode	92

Section 8. System Integration Module (SIM)

- 8.1 Contents 93
- 8.2 Introduction 94
- 8.3 SIM Bus Clock Control and Generation 96
 - 8.3.1 Bus Timing 97
 - 8.3.2 Clock Startup from POR or LVI Reset 97
 - 8.3.3 Clocks in Stop Mode and Wait Mode 97
- 8.4 Reset and System Initialization. 97
 - 8.4.1 External Pin Reset 98
 - 8.4.2 Active Resets from Internal Sources 99
 - 8.4.2.1 Power-On Reset 100
 - 8.4.2.2 Computer Operating Properly (COP) Reset. 101
 - 8.4.2.3 Illegal Opcode Reset 101
 - 8.4.2.4 Illegal Address Reset 101
 - 8.4.2.5 Low-Voltage Inhibit (LVI) Reset 102
 - 8.4.2.6 Universal Serial Bus Reset 102
 - 8.4.2.7 Registers Values After Different Resets. 102
- 8.5 SIM Counter 103
 - 8.5.1 SIM Counter During Power-On Reset 103
 - 8.5.2 SIM Counter During Stop Mode Recovery 104
 - 8.5.3 SIM Counter and Reset States. 104
- 8.6 Exception Control 104
 - 8.6.1 Interrupts 104
 - 8.6.1.1 Hardware Interrupts 107
 - 8.6.1.2 SWI Instruction. 108
 - 8.6.2 Interrupt Status Registers. 108
 - 8.6.2.1 Interrupt Status Register 1 109
 - 8.6.3 Reset 109
 - 8.6.4 Break Interrupts 109
 - 8.6.5 Status Flag Protection in Break Mode 110
- 8.7 Low-Power Modes 110
 - 8.7.1 Wait Mode 110
 - 8.7.2 Stop Mode 112
- 8.8 SIM Registers 113

8.8.1 Break Status Register 113
 8.8.2 Reset Status Register 114
 8.8.3 Break Flag Control Register 116

Section 9. Universal Serial Bus Module (USB)

9.1 Contents 117
 9.2 Introduction 118
 9.3 Features 119
 9.4 Pin Name Conventions 120
 9.5 Functional Description 124
 9.5.1 USB Protocol 125
 9.5.1.1 Sync Pattern 126
 9.5.1.2 Packet Identifier Field 127
 9.5.1.3 Address Field (ADDR) 128
 9.5.1.4 Endpoint Field (ENDP) 128
 9.5.1.5 Cyclic Redundancy Check (CRC) 128
 9.5.1.6 End-of-Packet (EOP) 128
 9.5.2 Reset Signaling 129
 9.5.3 Suspend 130
 9.5.4 Resume After Suspend 131
 9.5.4.1 Host Initiated Resume 131
 9.5.4.2 USB Reset Signalling 131
 9.5.4.3 Remote Wakeup 131
 9.5.5 Low-Speed Device 132
 9.6 Clock Requirements 132
 9.7 Hardware Description 133
 9.7.1 Voltage Regulator 133
 9.7.2 USB Transceiver 133
 9.7.2.1 Output Driver Characteristics 134
 9.7.2.2 Low Speed (1.5 Mbps) Driver Characteristics 134
 9.7.2.3 Receiver Data Jitter 135
 9.7.2.4 Data Source Jitter 135
 9.7.2.5 Data Signal Rise and Fall Time 136
 9.7.3 USB Control Logic 137

9.8	I/O Registers	137
9.8.1	USB Address Register	138
9.8.2	USB Interrupt Register 0	139
9.8.3	USB Interrupt Register 1	141
9.8.4	USB Interrupt Register 2	144
9.8.5	USB Control Register 0	145
9.8.6	USB Control Register 1	146
9.8.7	USB Control Register 2	147
9.8.8	USB Control Register 3	149
9.8.9	USB Control Register 4	151
9.8.10	USB Status Register 0	152
9.8.11	USB Status Register 1	153
9.8.12	USB Endpoint 0 Data Registers	154
9.8.13	USB Endpoint 1 Data Registers	155
9.8.14	USB Endpoint 2 Data Registers	156
9.9	USB Interrupts	157
9.9.1	USB End-of-Transaction Interrupt	157
9.9.1.1	Receive Control Endpoint 0	158
9.9.1.2	Transmit Control Endpoint 0	160
9.9.1.3	Transmit Endpoint 1	161
9.9.1.4	Transmit Endpoint 2	162
9.9.1.5	Receive Endpoint 2	162
9.9.2	Resume Interrupt	162
9.9.3	End-of-Packet Interrupt	162

Section 10. Monitor ROM (MON)

10.1	Contents	163
10.2	Introduction	163
10.3	Features	164
10.4	Functional Description	164
10.4.1	Entering Monitor Mode	166
10.4.2	Baud Rate	169
10.4.3	Data Format	170
10.4.4	Echoing	170
10.4.5	Break Signal	171

10.4.6	Commands	171
10.5	Security	175

Section 11. Timer Interface Module (TIM)

11.1	Contents	177
11.2	Introduction	178
11.3	Features	178
11.4	Pin Name Conventions	178
11.5	Functional Description	179
11.5.1	TIM Counter Prescaler	181
11.5.2	Input Capture	181
11.5.3	Output Compare	181
11.5.3.1	Unbuffered Output Compare	182
11.5.3.2	Buffered Output Compare	183
11.5.4	Pulse Width Modulation (PWM)	183
11.5.4.1	Unbuffered PWM Signal Generation	184
11.5.4.2	Buffered PWM Signal Generation	185
11.5.4.3	PWM Initialization	186
11.6	Interrupts	187
11.7	Low-Power Modes	187
11.7.1	Wait Mode	188
11.7.2	Stop Mode	188
11.8	TIM During Break Interrupts	188
11.9	I/O Signals	189
11.9.1	TIM Clock Pin (PTE0/TCLK)	189
11.9.2	TIM Channel I/O Pins (PTE1/TCH0:PTE2/TCH1)	189
11.10	I/O Registers	189
11.10.1	TIM Status and Control Register	190
11.10.2	TIM Counter Registers	192
11.10.3	TIM Counter Modulo Registers	193
11.10.4	TIM Channel Status and Control Registers	194
11.10.5	TIM Channel Registers	198

Section 12. Input/Output Ports (I/O)

12.1	Contents	199
12.2	Introduction	199
12.3	Port A	202
12.3.1	Port A Data Register	202
12.3.2	Data Direction Register A	203
12.4	Port B	204
12.4.1	Port B Data Register	204
12.4.2	Data Direction Register B	205
12.5	Port C	207
12.5.1	Port C Data Register	207
12.5.2	Data Direction Register C	208
12.6	Port D	209
12.6.1	Port D Data Register	210
12.6.2	Data Direction Register D	211
12.7	Port E	212
12.7.1	Port E Data Register	213
12.7.2	Data Direction Register E	215
12.8	Port Options	216
12.8.1	Port Option Control Register	217

Section 13. External Interrupt (IRQ)

13.1	Contents	219
13.2	Introduction	219
13.3	Features	219
13.4	Functional Description	220
13.5	IRQ Pin	222
13.6	PTE4/D- Pin	223
13.7	IRQ Module During Break Interrupts	223
13.8	IRQ Status and Control Register	224
13.9	IRQ Option Control Register	225

Section 14. Keyboard Interrupt Module (KBI)

14.1	Contents	227
14.2	Introduction	227
14.3	Features	228
14.4	Pin Name Conventions	228
14.5	Functional Description	230
14.6	Keyboard Initialization	231
14.7	Low-Power Modes	232
14.7.1	Wait Mode	232
14.7.2	Stop Mode	232
14.8	Keyboard Module During Break Interrupts	233
14.9	I/O Registers	233
14.9.1	Keyboard Status and Control Register	233
14.9.2	Keyboard Interrupt Enable Register	235

Section 15. Computer Operating Properly (COP)

15.1	Contents	237
15.2	Introduction	237
15.3	Functional Description	238
15.4	I/O Signals	239
15.4.1	OSCCLK	239
15.4.2	STOP Instruction	239
15.4.3	COPCTL Write	239
15.4.4	Power-On Reset	240
15.4.5	Internal Reset	240
15.4.6	Reset Vector Fetch	240
15.4.7	COPD (COP Disable)	240
15.4.8	COPRS (COP Rate Select)	240
15.5	COP Control Register	241
15.6	Interrupts	241

15.7	Monitor Mode	241
15.8	Low-Power Modes	242
15.8.1	Wait Mode	242
15.8.2	Stop Mode	242
15.9	COP Module During Break Mode	242

Section 16. Low Voltage Inhibit (LVI)

16.1	Contents	243
16.2	Introduction	243
16.3	Functional Description	243
16.4	LVI Control Register (CONFIG)	244
16.5	Low-Power Modes	244
16.5.1	Wait Mode	244
16.5.2	Stop Mode	244

Section 17. Break Module (BREAK)

17.1	Contents	245
17.2	Introduction	245
17.3	Features	246
17.4	Functional Description	246
17.4.1	Flag Protection During Break Interrupts	248
17.4.2	CPU During Break Interrupts	248
17.4.3	TIM During Break Interrupts	248
17.4.4	COP During Break Interrupts	248
17.5	Low-Power Modes	248
17.5.1	Wait Mode	248
17.5.2	Stop Mode	249
17.6	Break Module Registers	249
17.6.1	Break Status and Control Register	249
17.6.2	Break Address Registers	250
17.6.3	Break Status Register	250
17.6.4	Break Flag Control Register (BFCR)	252

Section 18. Electrical Specifications

18.1	Contents	253
18.2	Introduction	253
18.3	Absolute Maximum Ratings	254
18.4	Functional Operating Range	255
18.5	Thermal Characteristics	255
18.6	DC Electrical Characteristics	256
18.7	Control Timing	257
18.8	Oscillator Characteristics	257
18.9	USB DC Electrical Characteristics	258
18.10	USB Low-Speed Source Electrical Characteristics	259
18.11	USB Signaling Levels	260
18.12	Timer Interface Module Characteristics	260
18.13	Memory Characteristics	261

Section 19. Mechanical Specifications

19.1	Contents	263
19.2	Introduction	263
19.3	44-Pin Plastic Quad Flat Pack (QFP)	264
19.4	28-Pin Small Outline Integrated Circuit (SOIC)	265
19.5	20-Pin Dual In-Line Package (PDIP)	265
19.6	20-Pin Small Outline Integrated Circuit (SOIC)	266

Section 20. Ordering Information

20.1	Contents	267
20.2	Introduction	267
20.3	MC Order Numbers	267

Appendix A. MC68HC08JB8

A.1	Contents	269
A.2	Introduction	270
A.3	MCU Block Diagram	270
A.4	Memory Map	270
A.5	Reserved Registers	273
A.6	Monitor ROM	273
A.7	Electrical Specifications	273
A.7.1	DC Electrical Characteristics	274
A.7.2	Memory Characteristics	275
A.8	MC68HC08JB8 Order Numbers	275

Appendix B. MC68HC08JT8

B.1	Contents	277
B.2	Introduction	278
B.3	MCU Block Diagram	278
B.4	Memory Map	278
B.5	Power Supply Pins	281
B.6	Reserved Register Bit	281
B.7	Reserved Registers	281
B.8	Monitor ROM	282
B.9	Universal Serial Bus Module	282
B.10	Low-Voltage Inhibit Module	282
B.11	Electrical Specifications	282
B.11.1	Absolute Maximum Ratings	282
B.11.2	Functional Operating Range	283
B.11.3	DC Electrical Characteristics	283
B.11.4	Control Timing	284
B.11.5	Memory Characteristics	284
B.12	MC68HC08JT8 Order Numbers	284

List of Figures

Figure	Title	Page
1-1	MCU Block Diagram	31
1-2	44-Pin QFP Pin Assignments	32
1-3	28-pin SOIC Pin Assignments	33
1-4	20-pin PDIP and SOIC Pin Assignments	33
1-5	Power Supply Bypassing	34
1-6	Regulator Supply Capacitor Configuration	35
2-1	Memory Map	40
2-2	Control, Status, and Data Registers	42
4-1	FLASH Memory Register Summary	54
4-2	FLASH Control Register (FLCR)	55
4-3	FLASH Programming Flowchart	59
4-4	FLASH Block Protect Register (FLBPR)	60
4-5	FLASH Block Protect Start Address	60
5-1	Configuration Register (CONFIG)	66
6-1	CPU Registers	71
6-2	Accumulator (A)	71
6-3	Index Register (H:X)	72
6-4	Stack Pointer (SP)	72
6-5	Program Counter (PC)	73
6-6	Condition Code Register (CCR)	74
7-1	Oscillator External Connections	90
8-1	SIM Block Diagram	95
8-2	SIM I/O Register Summary	96
8-3	SIM Clock Signals	96

Figure	Title	Page
8-4	External Reset Timing	98
8-5	Internal Reset Timing	99
8-6	Sources of Internal Reset	99
8-7	POR Recovery	100
8-8	Interrupt Processing	105
8-9	Interrupt Entry	106
8-10	Interrupt Recovery	106
8-11	Interrupt Recognition Example	107
8-12	Interrupt Status Register 1 (INT1)	109
8-13	Wait Mode Entry Timing	111
8-14	Wait Recovery from Interrupt or Break	111
8-15	Wait Recovery from Internal Reset	111
8-16	Stop Mode Entry Timing	112
8-17	Stop Mode Recovery from Interrupt or Break	113
8-18	Break Status Register (BSR)	113
8-19	Reset Status Register (RSR)	115
8-20	Break Flag Control Register (BFCR)	116
9-1	USB I/O Register Summary	120
9-2	USB Block Diagram	124
9-3	Supported Transaction Types Per Endpoint	125
9-4	Supported USB Packet Types	126
9-5	Sync Pattern	126
9-6	SOP, Sync Signaling, and Voltage Levels	127
9-7	EOP Transaction Voltage Levels	129
9-8	EOP Width Timing	129
9-9	External Low-Speed Device Configuration	132
9-10	Regulator Electrical Connections	133
9-11	Receiver Characteristics	134
9-12	Differential Input Sensitivity Range	135
9-13	Data Jitter	136
9-14	Data Signal Rise and Fall Time	136
9-15	USB Address Register (UADDR)	138
9-16	USB Interrupt Register 0 (UIR0)	139
9-17	USB Interrupt Register 1 (UIR1)	141
9-18	USB Interrupt Register 2 (UIR2)	144

Figure	Title	Page
9-19	USB Control Register 0 (UCR0)	145
9-20	USB Control Register 1 (UCR1)	146
9-21	USB Control Register 2 (UCR2)	147
9-22	USB Control Register 3 (UCR3)	149
9-23	USB Control Register 4 (UCR4)	151
9-24	USB Status Register 0 (USR0)	152
9-25	USB Status Register 1 (USR1)	153
9-26	USB Endpoint 0 Data Registers (UE0D0–UE0D7)	154
9-27	USB Endpoint 1 Data Registers (UE1D0–UE1D7)	155
9-28	USB Endpoint 2 Data Registers (UE2D0–UE2D7)	156
9-29	OUT Token Data Flow for Receive Endpoint 0	158
9-30	SETUP Token Data Flow for Receive Endpoint 0	159
9-31	IN Token Data Flow for Transmit Endpoint 0	160
9-32	IN Token Data Flow for Transmit Endpoint 1	161
10-1	Monitor Mode Circuit.	165
10-2	Low-Voltage Monitor Mode Entry Flowchart.	168
10-3	Monitor Data Format.	170
10-4	Sample Monitor Waveforms	170
10-5	Read Transaction	170
10-6	Break Transaction.	171
10-7	Monitor Mode Entry Timing.	175
11-1	TIM Block Diagram	179
11-2	TIM I/O Register Summary	180
11-3	PWM Period and Pulse Width	184
11-4	TIM Status and Control Register (TSC)	190
11-5	TIM Counter Registers (TCNTH:TCNTL)	192
11-6	TIM Counter Modulo Registers (TMODH:TMODL)	193
11-7	TIM Channel Status and Control Registers (TSC0:TSC1)	194
11-8	CHxMAX Latency	197
11-9	TIM Channel Registers (TCH0H/L:TCH1H/L)	198
12-1	I/O Port Register Summary.	200
12-2	Port A Data Register (PTA)	202
12-3	Data Direction Register A (DDRA)	203

12-4	Port A I/O Circuit.	203
12-5	Port B Data Register (PTB)	204
12-6	Data Direction Register B (DDRB)	205
12-7	Port B I/O Circuit.	206
12-8	Port C Data Register (PTC)	207
12-9	Data Direction Register C (DDRC)	208
12-10	Port C I/O Circuit.	209
12-11	Port D Data Register (PTD)	210
12-12	Data Direction Register D (DDR D)	211
12-13	Port D I/O Circuit.	212
12-14	Port E Data Register (PTE)	213
12-15	Data Direction Register E (DDRE)	215
12-16	Port E I/O Circuit.	216
12-17	Port Option Control Register (POCR).	217
13-1	IRQ Module Block Diagram	221
13-2	IRQ I/O Register Summary.	221
13-3	IRQ Status and Control Register (ISCR)	224
13-4	IRQ Option Control Register (IOCR)	225
14-1	Keyboard Module Block Diagram	229
14-2	Keyboard Status and Control Register (KBSCR)	234
14-3	Keyboard Interrupt Enable Register (KBIER)	235
15-1	COP Block Diagram	238
15-2	Configuration Register (CONFIG).	240
15-3	COP Control Register (COPCTL).	241
16-1	LVI Module Block Diagram	244
16-2	Configuration Register (CONFIG).	244
17-1	Break Module Block Diagram	247
17-2	Break I/O Register Summary	247
17-3	Break Status and Control Register (BRKSCR).	249
17-4	Break Address Register High (BRKH)	250
17-5	Break Address Register Low (BRKL)	250
17-6	Break Status Register (BSR)	251
17-7	Break Flag Control Register High (BF CR)	252

Figure	Title	Page
19-1	44-Pin QFP (Case #824E)	264
19-2	28-Pin SOIC (Case #751F)	265
19-3	20-Pin PDIP (Case #738)	265
19-4	20-Pin SOIC (Case #751D)	266
A-1	MC68HC08JB8 Block Diagram	271
A-2	MC68HC08JB8 Memory Map	272
B-1	MC68HC08JT8 Block Diagram	279
B-2	MC68HC08JT8 Memory Map	280
B-3	Power Supply Bypassing	281



List of Tables

Table	Title	Page
1-1	Summary of Pin Functions	37
2-1	Vector Addresses	50
4-1	ROM-Resident Routines.	61
4-2	ROM-Resident Routine Variables.	62
4-3	ERASE Routine	62
4-4	PROGRAM Routine	63
4-5	VERIFY Routine	63
6-1	Instruction Set Summary	78
6-2	Opcode Map	87
8-1	SIM Module Signal Name Conventions	95
8-2	PIN Bit Set Timing	98
8-3	Registers not Affected by Normal Reset.	103
8-4	Interrupt Sources	108
9-1	USB Module Pin Name Conventions	120
9-2	Supported Packet Identifiers.	127
10-1	Mode Entry Requirements and Options	166
10-2	Monitor Mode Vector Differences.	169
10-3	Monitor Baud Rate Selection	169
10-4	READ (Read Memory) Command	172
10-5	WRITE (Write Memory) Command.	172
10-6	IREAD (Indexed Read) Command	173
10-7	IWRITE (Indexed Write) Command	173
10-8	READSP (Read Stack Pointer) Command.	174
10-9	RUN (Run User Program) Command.	174

11-1	TIM Pin Name Conventions	178
11-2	Prescaler Selection	191
11-3	Mode, Edge, and Level Selection	196
12-1	Port Control Register Bits Summary	201
12-2	Port A Pin Functions	204
12-3	Port B Pin Functions	206
12-4	Port C Pin Functions	209
12-5	Port D Pin Functions	212
12-6	Port E Pin Functions	216
14-1	KBI Pin Name Conventions	228
14-2	I/O Register Summary	229
20-1	MC Order Numbers	267
A-1	Summary of MC68HC08JB8 and MC68HC908JB8 Differences.	270
A-2	MC68HC08JB8 Order Numbers	275
B-1	Summary of MC68HC08JT8 and MC68HC908JB8 Differences.	278
B-2	MC68HC08JT8 Order Numbers	284

Section 1. General Description

1.1 Contents

1.2	Introduction	27
1.3	Features	28
1.4	MCU Block Diagram	30
1.5	Pin Assignments	32
1.5.1	Power Supply Pins (V_{DD} , V_{SS})	34
1.5.2	Voltage Regulator Out (V_{REG})	34
1.5.3	Oscillator Pins (OSC1 and OSC2)	35
1.5.4	External Reset Pin (\overline{RST})	35
1.5.5	External Interrupt Pins (\overline{IRQ} , PTE4/D $-$)	35
1.5.6	Port A Input/Output (I/O) Pins (PTA7/ $\overline{KBA7}$ –PTA0/ $\overline{KBA0}$)	36
1.5.7	Port B (I/O) Pins (PTB7–PTB0)	36
1.5.8	Port C I/O Pins (PTC7–PTC0)	36
1.5.9	Port D I/O Pins (PTD7–PTD0)	36
1.5.10	Port E I/O Pins (PTE4/D $-$, PTE3/D $+$, PTE2/TCH1, PTE1/TCH0, PTE0/TCLK)	36

1.2 Introduction

The MC68HC908JB8 is a member of the low-cost, high-performance M68HC08 Family of 8-bit microcontroller units (MCUs). All MCUs in the family use the enhanced M68HC08 central processor unit (CPU08) and are available with a variety of modules, memory sizes and types, and package types.

1.3 Features

Features of the MC68HC908JB8 include:

- High-performance M68HC08 architecture
- Fully upward-compatible object code with M6805, M146805, and M68HC05 Families
- 3-MHz internal bus frequency
- 8,192 bytes of on-chip FLASH memory
- 256 bytes of on-chip random-access memory (RAM)
- FLASH program memory security¹
- On-chip programming firmware for use with host PC computer
- Up to 37 general-purpose 3.3V input/output (I/O) pins, including:
 - 13 or 10 shared-function I/O pins, depending on package
 - 24, 8, or 2 dedicated I/O pins, depending on package
 - 8 keyboard interrupts on port A, on all packages
 - 10mA sink capability for normal LED on 4 pins
 - 25mA sink capability for infrared LED on 2 pins
 - 10mA sink capability for PS/2 connection on 2 pins (with USB module disabled)
- 16-bit, 2-channel timer interface module (TIM) with selectable input capture, output compare, PWM capability on each channel, and external clock input option (TCLK)
- Full Universal Serial Bus Specification 1.1 low-speed functions:
 - 1.5 Mbps data rate
 - On-chip 3.3V regulator
 - Endpoint 0 with 8-byte transmit buffer and 8-byte receive buffer
 - Endpoint 1 with 8-byte transmit buffer
 - Endpoint 2 with 8-byte transmit buffer and 8-byte receive buffer

1. No security feature is absolutely secure. However, Freescale's strategy is to make reading or copying the FLASH difficult for unauthorized users.

- System protection features:
 - Optional computer operating properly (COP) reset
 - Optional low-voltage detection with reset
 - Illegal opcode detection with reset
 - Illegal address detection with reset
- Low-power design (fully static with stop and wait modes)
- Master reset pin with internal pullup and power-on reset
- External interrupt pin with programmable internal pullup (\overline{IRQ})
- 44-pin quad flat pack (QFP), 28-pin small outline integrated circuit package (SOIC), 20-pin small outline integrated circuit package (SOIC), and 20-pin plastic dual in-line package (DIP)
- Specific features of MC68HC908JB8 in 44-pin are:
 - Port B is 8 bits: PTB0–PTB7
 - Port C is 8 bits: PTC0–PTC7
 - Port D is 8 bits: PTD0–PTD7
 - Port E is 5 bits: PTE0–PTE4;
2-channel TIM module with TCLK input option
- Specific features of MC68HC908JB8 in 28-pin are:
 - Port B is not available
 - Port C is only one bit: PTC0
 - Port D is only 7 bits: PTD0–PTD6
 - Port E is 5 bits: PTE0–PTE4;
2-channel TIM module with TCLK input option
- Specific features of MC68HC908JB8 in 20-pin are:
 - Port B is not available
 - Port C is only one bit: PTC0
 - Port D is only one bit: PTD0/1; internal PTD0 and PTD1 pads are bonded together to a single pin, PTD0/1
 - Port E is only 3 bits: PTE1, PTE3, and PTE4;
1-channel TIM module without TCLK input option

Features of the CPU08 include the following:

- Enhanced HC05 programming model
- Extensive loop control functions
- 16 addressing modes (eight more than the HC05)
- 16-bit index register and stack pointer
- Memory-to-memory data transfers
- Fast 8×8 multiply instruction
- Fast 16/8 divide instruction
- Binary-coded decimal (BCD) instructions
- Optimization for controller applications
- Efficient C language support

1.4 MCU Block Diagram

Figure 1-1 shows the structure of the MC68HC908JB8.

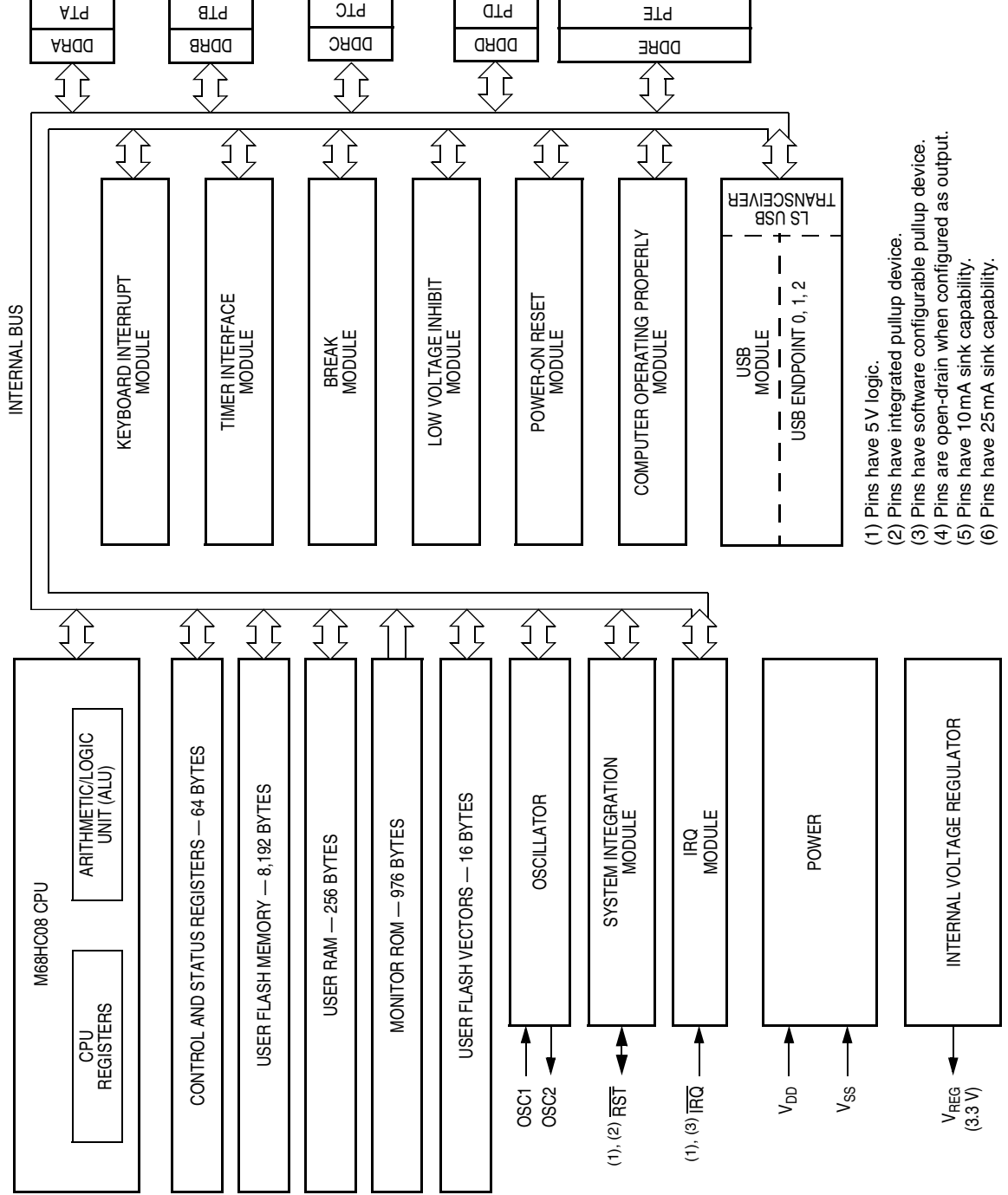

- (1) Pins have 5 V logic.
- (2) Pins have integrated pullup device.
- (3) Pins have software configurable pullup device.
- (4) Pins are open-drain when configured as output.
- (5) Pins have 10 mA sink capability.
- (6) Pins have 25 mA sink capability.

Figure 1-1. MCU Block Diagram



1.5 Pin Assignments

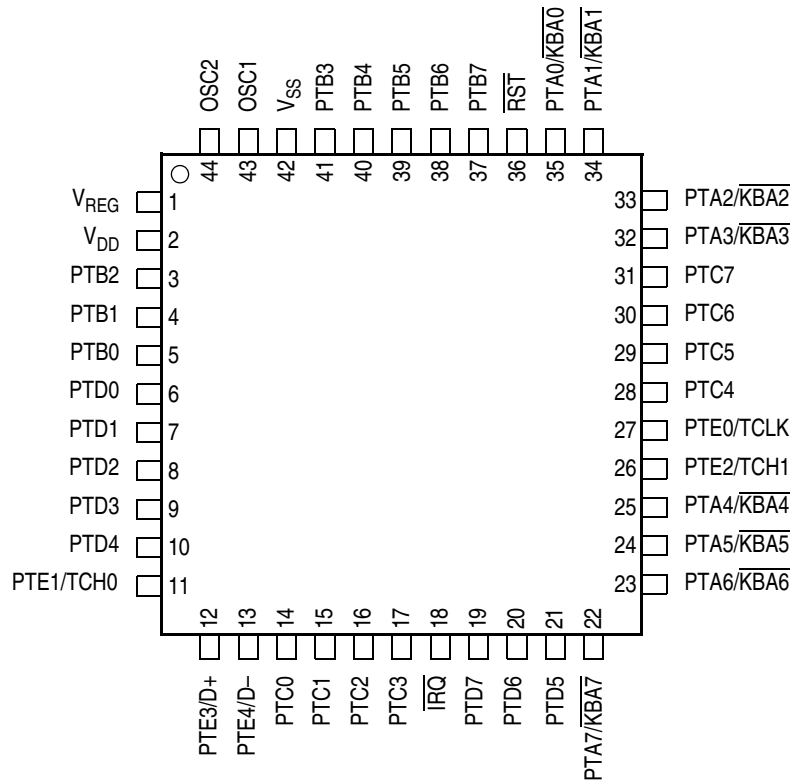

Figure 1-2. 44-Pin QFP Pin Assignments

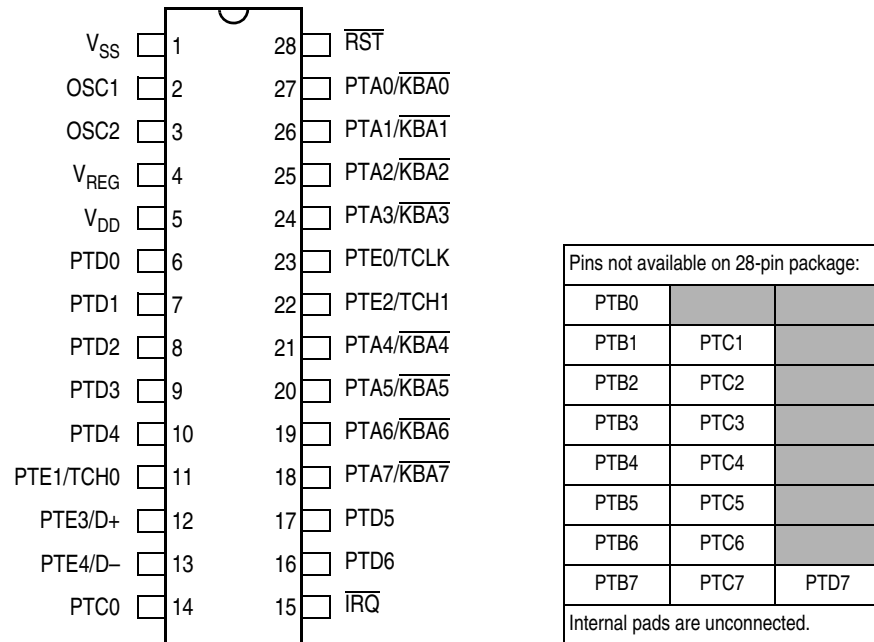

Figure 1-3. 28-Pin SOIC Pin Assignments

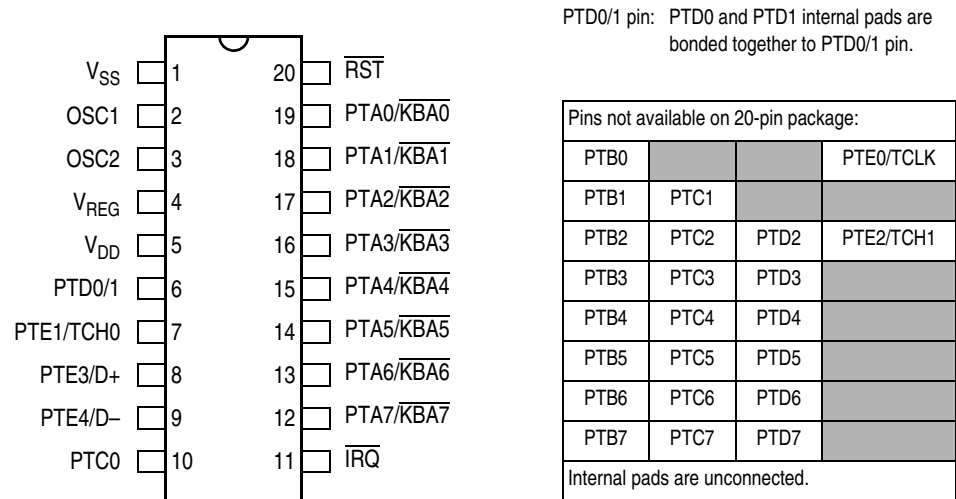

Figure 1-4. 20-Pin PDIP and SOIC Pin Assignments

NOTE: In 20-pin package, the PTD0 and PTD1 internal pads are bonded together to PTD0/1 pin.

1.5.1 Power Supply Pins (V_{DD} , V_{SS})

V_{DD} and V_{SS} are the power supply and ground pins. The MCU operates from a single power supply.

Fast signal transitions on MCU pins place high, short-duration current demands on the power supply. To prevent noise problems, take special care to provide power supply bypassing at the MCU as **Figure 1-5** shows. Place the bypass capacitors as close to the MCU power pins as possible. Use high-frequency-response ceramic capacitors for C_{BYPASS} . C_{BULK} are optional bulk current bypass capacitors for use in applications that require the port pins to source high current levels.

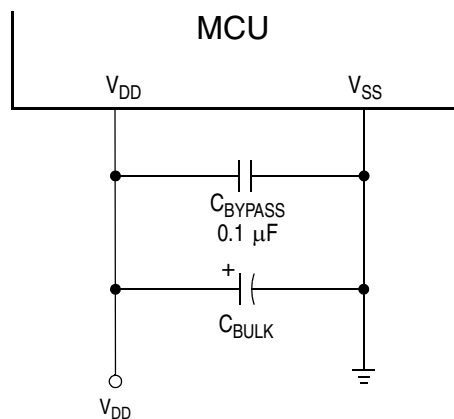

NOTE: Values shown are typical values.

Figure 1-5. Power Supply Bypassing

1.5.2 Voltage Regulator Out (V_{REG})

V_{REG} is the 3.3 V output of the on-chip voltage regulator. V_{REG} is used internally for the MCU operation and the USB data driver. It is also used to supply the voltage for the external pullup resistor required on the USB's D– line. The V_{REG} pin requires an external bulk capacitor $4.7 \mu F$ or larger and a $0.1 \mu F$ ceramic bypass capacitor as **Figure 1-6** shows. Place the bypass capacitors as close to the V_{REG} pin as possible.

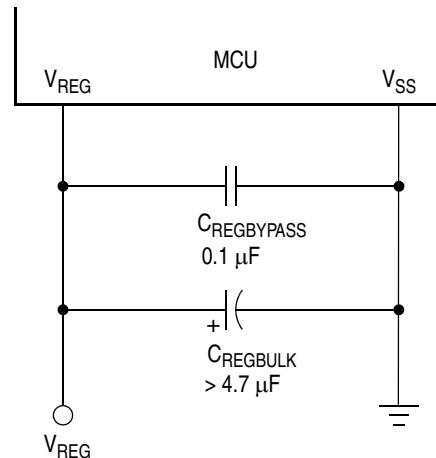

Figure 1-6. Regulator Supply Capacitor Configuration

1.5.3 Oscillator Pins (OSC1 and OSC2)

The OSC1 and OSC2 pins are the connections for the on-chip oscillator circuit.

1.5.4 External Reset Pin (\overline{RST})

A logic zero on the \overline{RST} pin forces the MCU to a known start-up state. \overline{RST} is bidirectional, allowing a reset of the entire system. It is driven low when any internal reset source is asserted. The \overline{RST} pin contains an internal pullup device to V_{DD} . (See [Section 8. System Integration Module \(SIM\)](#).)

1.5.5 External Interrupt Pins (\overline{IRQ} , PTE4/D-)

\overline{IRQ} is an asynchronous external interrupt pin. \overline{IRQ} is also the pin to enter monitor mode. The \overline{IRQ} pin contains a software configurable pullup device to V_{DD} . PTE4/D- can be programmed to trigger the IRQ interrupt. (See [Section 13. External Interrupt \(IRQ\)](#).)

1.5.6 Port A Input/Output (I/O) Pins (PTA7/ $\overline{\text{KBA7}}$ –PTA0/ $\overline{\text{KBA0}}$)

PTA7/ $\overline{\text{KBA7}}$ –PTA0/ $\overline{\text{KBA0}}$ are general-purpose bidirectional I/O port pins. (See [Section 12. Input/Output Ports \(I/O\)](#).) Each pin contains a software configurable pullup device to V_{REG} when the pin is configured as an input. (See [12.8 Port Options](#).) Each pin can also be programmed as an external keyboard interrupt pin. (See [Section 14. Keyboard Interrupt Module \(KBI\)](#).)

1.5.7 Port B (I/O) Pins (PTB7–PTB0)

PTB7–PTB0 are general-purpose bidirectional I/O port pins. Each pin contains a software configurable pullup device to V_{REG} when the pin is configured as an input. (See [12.8 Port Options](#).)

1.5.8 Port C I/O Pins (PTC7–PTC0)

PTC7–PTC0 are general-purpose bidirectional I/O port pins. (See [Section 12. Input/Output Ports \(I/O\)](#).) Each pin contains a software configurable pullup device to V_{REG} when the pin is configured as an input. (See [12.8 Port Options](#).)

1.5.9 Port D I/O Pins (PTD7–PTD0)

PTD7–PTD0 are general-purpose bidirectional I/O port pins; open-drain when configured as output. (See [Section 12. Input/Output Ports \(I/O\)](#).) PTD5–PTD2 are software configurable to be 10mA sink pins for direct LED connections. PTD1–PTD0 are software configurable to be 25mA sink pins for direct infrared LED connections. (See [12.8 Port Options](#).)

1.5.10 Port E I/O Pins (PTE4/D $^-$, PTE3/D $^+$, PTE2/TCH1, PTE1/TCH0, PTE0/TCLK)

Port E is a 5-bit special function port that shares two of its pins with the USB module and three of its pins with the timer interface module.

Each PTE2–PTE0 pin contains a software configurable pullup device to V_{REG} when the pin is configured as an input or output.

When the USB module is disabled, the PTE4 and PTE3 pins are general-purpose bidirectional I/O port pins with 10mA sink capability. Each pin is open-drain when configured as an output; and each pin contains a software configurable 5kΩ pullup to V_{DD} when configured as an input. The PTE4 pin can also be enabled to trigger the IRQ interrupt.

When the USB module is enabled, the PTE4/D– and PTE3/D+ pins become the USB module D– and D+ pins. The D– pin contains a software configurable 1.5kΩ pullup to V_{REG} . (See [Section 11. Timer Interface Module \(TIM\)](#), [Section 9. Universal Serial Bus Module \(USB\)](#) and [Section 12. Input/Output Ports \(I/O\)](#).)

Summary of the pin functions are provided in [Table 1-1](#).

Table 1-1. Summary of Pin Functions

PIN NAME	PIN DESCRIPTION	IN/OUT	VOLTAGE LEVEL
V_{DD}	Power supply.	IN	4.0 to 5.5V
V_{SS}	Power supply ground.	OUT	0V
V_{REG}	Regulated 3.3V output from MCU.	OUT	V_{REG} (3.3V)
\overline{RST}	Reset input; active low. With internal pullup to V_{DD} and schmitt trigger input.	IN/OUT	V_{DD}
\overline{IRQ}	External IRQ pin; with programmable internal pullup to V_{DD} and schmitt trigger input.	IN	V_{DD}
	Used for mode entry selection.	IN	V_{REG} to $V_{DD} + V_{HI}$
OSC1	Crystal oscillator input.	IN	V_{REG}
OSC2	Crystal oscillator output; inverting of OSC1 signal.	OUT	V_{REG}
PTA0/ $\overline{KBA0}$: PTA7/ $\overline{KBA7}$	8-bit general-purpose I/O port.	IN/OUT	V_{REG}
	Pins as keyboard interrupts, $\overline{KBA0}$ – $\overline{KBA7}$.	IN	V_{REG}
PTB0–PTB7	Each pin has programmable internal pullup to V_{REG} when configured as input.	IN	V_{REG}
	8-bit general-purpose I/O port.	IN/OUT	V_{REG}
	Each pin has programmable internal pullup to V_{REG} when configured as input.	IN	V_{REG}

Table 1-1. Summary of Pin Functions

PIN NAME	PIN DESCRIPTION	IN/OUT	VOLTAGE LEVEL
PTC0–PTC7	8-bit general-purpose I/O port.	IN/OUT	V_{REG}
	Each pin has programmable internal pullup to V_{REG} when configured as input.	IN	V_{REG}
PTD0–PTD7	8-bit general-purpose I/O port; open-drain when configured as output.	IN OUT	V_{REG} V_{REG} or V_{DD}
	PTD0–PTD1 have configurable 25mA sink for infrared LED.	OUT	V_{REG} or V_{DD}
	PTD2–PTD5 have configurable 10mA sink for LED.	OUT	V_{REG} or V_{DD}
PTE0/TCLK PTE1/TCH0 PTE2/TCH1	PTE0–PTE2 are general-purpose I/O pins.	IN/OUT	V_{REG}
	PTE0–PTE2 have programmable internal pullup to V_{REG} when configured as input or output.	IN/OUT	V_{REG}
	PTE0 as TCLK of timer interface module.	IN	V_{REG}
	PTE1 as TCH0 of timer interface module.	IN/OUT	V_{REG}
	PTE2 as TCH1 of timer interface module.	IN/OUT	V_{REG}
PTE3/D+ PTE4/D–	PTE3–PTE4 are general-purpose I/O pins; open-drain when configured as output.	IN OUT	V_{DD} V_{REG} or V_{DD}
	PTE3–PTE4 have programmable internal pullup to V_{DD} when configured as input.	IN	V_{DD}
	PTE3 as D+ of USB module.	IN/OUT	V_{REG}
	PTE4 as D– of USB module.	IN/OUT	V_{REG}
	PTE4 as additional IRQ interrupt.	IN	V_{DD}

Section 2. Memory Map

2.1 Contents

2.2	Introduction	39
2.3	I/O Section	41
2.4	Monitor ROM	41

2.2 Introduction

The CPU08 can address 64 Kbytes of memory space. The memory map, shown in **Figure 2-1**, includes:

- 8,192 bytes of user FLASH memory
- 256 bytes of RAM
- 16 bytes of user-defined vectors
- 976 bytes of monitor ROM

Memory Map

\$0000 ↓ \$003F	I/O Registers 64 Bytes
\$0040 ↓ \$013F	RAM 256 Bytes
\$0140 ↓ \$DBFF	Unimplemented 56,000 Bytes
\$DC00 ↓ \$FBFF	FLASH 8,192 Bytes
\$FC00 ↓ \$FDFF	Monitor ROM 1 512 Bytes
\$FE00	Break Status Register (BSR)
\$FE01	Reset Status Register (RSR)
\$FE02	Reserved
\$FE03	Break Flag Control Register (BFCR)
\$FE04	Interrupt Status Register 1 (INT1)
\$FE05	Reserved
\$FE06	Reserved
\$FE07	Reserved
\$FE08	FLASH Control Register (FLCR)
\$FE09	FLASH Block Protect Register (FLBPR)
\$FE0A	Reserved
\$FE0B	Reserved
\$FE0C	Break Address High Register (BRKH)
\$FE0D	Break Address Low Register (BRKL)
\$FE0E	Break Status and Control Register (BRKSCR)
\$FE0F	Reserved
\$FE10 ↓ \$FFDF	Monitor ROM 2 464 Bytes
\$FFE0 ↓ \$FFEF	Reserved 16 Bytes
\$FFF0 ↓ \$FFFF	FLASH Vectors 16 Bytes

Figure 2-1. Memory Map

2.3 I/O Section

Addresses \$0000–\$003F, shown in [Figure 2-2](#), contain most of the control, status, and data registers. Additional I/O registers have these addresses:

- \$FE00; break status register, BSR
- \$FE01; reset status register, RSR
- \$FE02; reserved
- \$FE03; break flag control register, BFCR
- \$FE04; interrupt status register 1, INT1
- \$FE05; reserved
- \$FE06; reserved
- \$FE07; reserved
- \$FE08; FLASH control register, FLCR
- \$FE09; FLASH block protect register, FLBPR
- \$FE0A; reserved
- \$FE0B; reserved
- \$FE0C; break Address Register High, BRKH
- \$FE0D; break Address Register Low, BRKL
- \$FE0E; break status and control register, BRKSCR
- \$FFFF; COP control register, COPCTL

2.4 Monitor ROM

The 512 bytes at addresses \$FC00–\$FDFF and 464 bytes at addresses \$FE10–\$FFDF are reserved ROM addresses that contain the instructions for the monitor functions. (See [Section 10. Monitor ROM \(MON\)](#).)

Memory Map

Addr.	Register Name	Bit 7	6	5	4	3	2	1	Bit 0	
\$0000	Port A Data Register (PTA)	Read:	PTA7	PTA6	PTA5	PTA4	PTA3	PTA2	PTA1	PTA0
		Write:								
		Reset:	Unaffected by reset							
\$0001	Port B Data Register (PTB)	Read:	PTB7	PTB6	PTB5	PTB4	PTB3	PTB2	PTB1	PTB0
		Write:								
		Reset:	Unaffected by reset							
\$0002	Port C Data Register (PTC)	Read:	PTC7	PTC6	PTC5	PTC4	PTC3	PTC2	PTC1	PTC0
		Write:								
		Reset:	Unaffected by reset							
\$0003	Port D Data Register (PTD)	Read:	PTD7	PTD6	PTD5	PTD4	PTD3	PTD2	PTD1	PTD0
		Write:								
		Reset:	Unaffected by reset							
\$0004	Data Direction Register A (DDRA)	Read:	DDRA7	DDRA6	DDRA5	DDRA4	DDRA3	DDRA2	DDRA1	DDRA0
		Write:								
		Reset:	0*	0	0	0	0	0	0	0

* DDRA7 bit is reset by POR or LVI reset only.

\$0005	Data Direction Register B (DDRB)	Read:	DDRB7	DDRB6	DDRB5	DDRB4	DDRB3	DDRB2	DDRB1	DDRB0
		Write:								
		Reset:	0	0	0	0	0	0	0	0
\$0006	Data Direction Register C (DDRC)	Read:	DDRC7	DDRC6	DDRC5	DDRC4	DDRC3	DDRC2	DDRC1	DDRC0
		Write:								
		Reset:	0	0	0	0	0	0	0	0
\$0007	Data Direction Register D (DDRD)	Read:	DDRD7	DDRD6	DDRD5	DDRD4	DDRD3	DDRD2	DDRD1	DDRD0
		Write:								
		Reset:	0	0	0	0	0	0	0	0
\$0008	Port E Data Register (PTE)	Read:	0	0	0	PTE4	PTE3	PTE2	PTE1	PTE0
		Write:								
		Reset:	Unaffected by reset							
\$0009	Data Direction Register E (DDRE)	Read:	0	0	0	DDRE4	DDRE3	DDRE2	DDRE1	DDRE0
		Write:								
		Reset:	0	0	0	0	0	0	0	0

= Unimplemented
 R = Reserved
 U = Unaffected by reset

Figure 2-2. Control, Status, and Data Registers (Sheet 1 of 8)

Addr.	Register Name	Bit 7	6	5	4	3	2	1	Bit 0	
\$000A	TIM Status and Control Register (TSC)	Read:	TOF	TOIE	TSTOP	0	0	PS2	PS1	PS0
		Write:	0			TRST				
		Reset:	0	0	1	0	0	0	0	0
\$000B	Unimplemented	Read:								
		Write:								
\$000C	TIM Counter Register High (TCNTH)	Read:	Bit15	Bit14	Bit13	Bit12	Bit11	Bit10	Bit9	Bit8
		Write:								
		Reset:	0	0	0	0	0	0	0	0
\$000D	TIM Counter Register Low (TCNTL)	Read:	Bit7	Bit6	Bit5	Bit4	Bit3	Bit2	Bit1	Bit0
		Write:								
		Reset:	0	0	0	0	0	0	0	0
\$000E	TIM Counter Modulo Register High (TMODH)	Read:	Bit15	Bit14	Bit13	Bit12	Bit11	Bit10	Bit9	Bit8
		Write:								
		Reset:	1	1	1	1	1	1	1	1
\$000F	TIM Counter Modulo Register Low (TMODL)	Read:	Bit7	Bit6	Bit5	Bit4	Bit3	Bit2	Bit1	Bit0
		Write:								
		Reset:	1	1	1	1	1	1	1	1
\$0010	TIM Channel 0 Status and Control Register (TSC0)	Read:	CH0F	CH0IE	MS0B	MS0A	ELS0B	ELS0A	TOV0	CH0MAX
		Write:	0							
		Reset:	0	0	0	0	0	0	0	0
\$0011	TIM Channel 0 Register High (TCH0H)	Read:	Bit15	Bit14	Bit13	Bit12	Bit11	Bit10	Bit9	Bit8
		Write:								
		Reset:	Indeterminate after reset							
\$0012	TIM Channel 0 Register Low (TCH0L)	Read:	Bit7	Bit6	Bit5	Bit4	Bit3	Bit2	Bit1	Bit0
		Write:								
		Reset:	Indeterminate after reset							
\$0013	TIM Channel 1 Status and Control Register (TSC1)	Read:	CH1F	CH1IE	0	MS1A	ELS1B	ELS1A	TOV1	CH1MAX
		Write:	0							
		Reset:	0	0	0	0	0	0	0	0

= Unimplemented
R = Reserved
U = Unaffected by reset

Figure 2-2. Control, Status, and Data Registers (Sheet 2 of 8)

Memory Map

Addr.	Register Name	Bit 7	6	5	4	3	2	1	Bit 0	
\$0014	TIM Channel 1 Register High (TCH1H)	Read:	Bit15	Bit14	Bit13	Bit12	Bit11	Bit10	Bit9	Bit8
		Write:								
		Reset:	Indeterminate after reset							
\$0015	TIM Channel 1 Register Low (TCH1L)	Read:	Bit7	Bit6	Bit5	Bit4	Bit3	Bit2	Bit1	Bit0
		Write:								
		Reset:	Indeterminate after reset							
\$0016	Keyboard Status and Control Register (KBSCR)	Read:	0	0	0	0	KEYF	0	IMASKK	MODEK
		Write:						ACKK		
		Reset:	0	0	0	0	0	0	0	0
\$0017	Keyboard Interrupt Enable Register (KBIER)	Read:	KBIE7	KBIE6	KBIE5	KBIE4	KBIE3	KBIE2	KBIE1	KBIE0
		Write:								
		Reset:	0	0	0	0	0	0	0	0
\$0018	USB Interrupt Register 2 (UIR2)	Read:	0	0	0	0	0	0	0	0
		Write:	EOPFR	RSTFR	TXD2FR	RXD2FR	TDX1FR	RESUMFR	TXD0FR	RXD0FR
		Reset:	0	0	0	0	0	0	0	0
\$0019	USB Control Register 2 (UCR2)	Read:	T2SEQ	STALL2	TX2E	RX2E	TP2SIZ3	TP2SIZ2	TP2SIZ1	TP2SIZ0
		Write:								
		Reset:	0	0	0	0	0	0	0	0
\$001A	USB Control Register 3 (UCR3)	Read:	TX1ST	0	OSTALL0	ISTALL0	0	PULLEN	ENABLE2	ENABLE1
		Write:		TX1STR						
		Reset:	0	0	0	0	0	0*	0	0

* PULLEN bit is reset by POR or LVI reset only.

\$001B	USB Control Register 4 (UCR4)	Read:	0	0	0	0	0	FUSBO	FDP	FDM
		Write:								
		Reset:	0	0	0	0	0	0	0	0
\$001C	IRQ Option Control Register (IOCR)	Read:	0	0	0	0	0	PTE4IF	PTE4IE	IRQPD
		Write:								
		Reset:	0	0	0	0	0	0	0	0
\$001D	Port Option Control Register (POCR)	Read:	PTE20P	PTDLDD	PTDILDD	PTE4P	PTE3P	PCP	PBP	PAP
		Write:								
		Reset:	0	0	0	0	0	0	0	0

= Unimplemented
R = Reserved
U = Unaffected by reset

Figure 2-2. Control, Status, and Data Registers (Sheet 3 of 8)

Addr.	Register Name		Bit 7	6	5	4	3	2	1	Bit 0
\$001E	IRQ Status and Control Register (ISCR)	Read:	0	0	0	0	IRQF	0	IMASK	MODE
		Write:						ACK		
		Reset:	0	0	0	0	0	0	0	0
\$001F	Configuration Register (CONFIG) [†]	Read:	0	0	URSTD	LVID	SSREC	COPRS	STOP	COPD
		Write:								
		Reset:	0	0	0	0	0	0	0	0

[†] One-time writable register after each reset. URSTD and LVID bits are reset by POR or LVI reset only.

\$0020	USB Endpoint 0 Data Register 0 (UE0D0)	Read:	UE0R07	UE0R06	UE0R05	UE0R04	UE0R03	UE0R02	UE0R01	UE0R00
		Write:	UE0T07	UE0T06	UE0T05	UE0T04	UE0T03	UE0T02	UE0T01	UE0T00
		Reset:	Unaffected by reset							
\$0021	USB Endpoint 0 Data Register 1 (UE0D1)	Read:	UE0R17	UE0R16	UE0R15	UE0R14	UE0R13	UE0R12	UE0R11	UE0R10
		Write:	UE0T17	UE0T16	UE0T15	UE0T14	UE0T13	UE0T12	UE0T11	UE0T10
		Reset:	Unaffected by reset							
\$0022	USB Endpoint 0 Data Register 2 (UE0D2)	Read:	UE0R27	UE0R26	UE0R25	UE0R24	UE0R23	UE0R22	UE0R21	UE0R20
		Write:	UE0T27	UE0T26	UE0T25	UE0T24	UE0T23	UE0T22	UE0T21	UE0T20
		Reset:	Unaffected by reset							
\$0023	USB Endpoint 0 Data Register 3 (UE0D3)	Read:	UE0R37	UE0R36	UE0R35	UE0R34	UE0R33	UE0R32	UE0R31	UE0R30
		Write:	UE0T37	UE0T36	UE0T35	UE0T34	UE0T33	UE0T32	UE0T31	UE0T30
		Reset:	Unaffected by reset							
\$0024	USB Endpoint 0 Data Register 4 (UE0D4)	Read:	UE0R47	UE0R46	UE0R45	UE0R44	UE0R43	UE0R42	UE0R41	UE0R40
		Write:	UE0T47	UE0T46	UE0T45	UE0T44	UE0T43	UE0T42	UE0T41	UE0T40
		Reset:	Unaffected by reset							
\$0025	USB Endpoint 0 Data Register 5 (UE0D5)	Read:	UE0R57	UE0R56	UE0R55	UE0R54	UE0R53	UE0R52	UE0R51	UE0R50
		Write:	UE0T57	UE0T56	UE0T55	UE0T54	UE0T53	UE0T52	UE0T51	UE0T50
		Reset:	Unaffected by reset							
\$0026	USB Endpoint 0 Data Register 6 (UE0D6)	Read:	UE0R67	UE0R66	UE0R65	UE0R64	UE0R63	UE0R62	UE0R61	UE0R60
		Write:	UE0T67	UE0T66	UE0T65	UE0T64	UE0T63	UE0T62	UE0T61	UE0T60
		Reset:	Unaffected by reset							
\$0027	USB Endpoint 0 Data Register 7 (UE0D7)	Read:	UE0R77	UE0R76	UE0R75	UE0R74	UE0R73	UE0R72	UE0R71	UE0R70
		Write:	UE0T77	UE0T76	UE0T75	UE0T74	UE0T73	UE0T72	UE0T71	UE0T70
		Reset:	Unaffected by reset							

= Unimplemented
 = Reserved
 U = Unaffected by reset

Figure 2-2. Control, Status, and Data Registers (Sheet 4 of 8)

Memory Map

Addr.	Register Name	Bit 7	6	5	4	3	2	1	Bit 0	
\$0028	USB Endpoint 1 Data Register 0 (UE1D0)	Read:								
		Write:	UE1T07	UE1T06	UE1T05	UE1T04	UE1T03	UE1T02	UE1T01	UE1T00
		Reset:	Unaffected by reset							
\$0029	USB Endpoint 1 Data Register 1 (UE1D1)	Read:								
		Write:	UE1T17	UE1T16	UE1T15	UE1T14	UE1T13	UE1T12	UE1T11	UE1T10
		Reset:	Unaffected by reset							
\$002A	USB Endpoint 1 Data Register 2 (UE1D2)	Read:								
		Write:	UE1T27	UE1T26	UE1T25	UE1T24	UE1T23	UE1T22	UE1T21	UE1T20
		Reset:	Unaffected by reset							
\$002B	USB Endpoint 1 Data Register 3 (UE1D3)	Read:								
		Write:	UE1T37	UE1T36	UE1T35	UE1T34	UE1T33	UE1T32	UE1T31	UE1T30
		Reset:	Unaffected by reset							
\$002C	USB Endpoint 1 Data Register 4 (UE1D4)	Read:								
		Write:	UE1T47	UE1T46	UE1T45	UE1T44	UE1T43	UE1T42	UE1T41	UE1T40
		Reset:	Unaffected by reset							
\$002D	USB Endpoint 1 Data Register 5 (UE1D5)	Read:								
		Write:	UE1T57	UE1T56	UE1T55	UE1T54	UE1T53	UE1T52	UE1T51	UE1T50
		Reset:	Unaffected by reset							
\$002E	USB Endpoint 1 Data Register 6 (UE1D6)	Read:								
		Write:	UE1T67	UE1T66	UE1T65	UE1T64	UE1T63	UE1T62	UE1T61	UE1T60
		Reset:	Unaffected by reset							
\$002F	USB Endpoint 1 Data Register 7 (UE1D7)	Read:								
		Write:	UE1T77	UE1T76	UE1T75	UE1T74	UE1T73	UE1T72	UE1T71	UE1T70
		Reset:	Unaffected by reset							
\$0030	USB Endpoint 2 Data Register 0 (UE2D0)	Read:	UE2R07	UE2R06	UE2R05	UE2R04	UE2R03	UE2R02	UE2R01	UE2R00
		Write:	UE2T07	UE2T06	UE2T05	UE2T04	UE2T03	UE2T02	UE2T01	UE2T00
		Reset:	Unaffected by reset							
\$0031	USB Endpoint 2 Data Register 1 (UE2D1)	Read:	UE2R17	UE2R16	UE2R15	UE2R14	UE2R13	UE2R12	UE2R11	UE2R10
		Write:	UE2T17	UE2T16	UE2T15	UE2T14	UE2T13	UE2T12	UE2T11	UE2T10
		Reset:	Unaffected by reset							

= Unimplemented
 R = Reserved
 U = Unaffected by reset

Figure 2-2. Control, Status, and Data Registers (Sheet 5 of 8)

Addr.	Register Name		Bit 7	6	5	4	3	2	1	Bit 0
\$0032	USB Endpoint 2 Data Register 2 (UE2D2)	Read:	UE2R27	UE2R26	UE2R25	UE2R24	UE2R23	UE2R22	UE2R21	UE2R20
		Write:	UE2T27	UE2T26	UE2T25	UE2T24	UE2T23	UE2T22	UE2T21	UE2T20
		Reset:	Unaffected by reset							
\$0033	USB Endpoint 2 Data Register 3 (UE2D3)	Read:	UE2R37	UE2R36	UE2R35	UE2R34	UE2R33	UE2R32	UE2R31	UE2R30
		Write:	UE2T37	UE2T36	UE2T35	UE2T34	UE2T33	UE2T32	UE2T31	UE2T30
		Reset:	Unaffected by reset							
\$0034	USB Endpoint 2 Data Register 4 (UE2D4)	Read:	UE2R47	UE2R46	UE2R45	UE2R44	UE2R43	UE2R42	UE2R41	UE2R40
		Write:	UE2T47	UE2T46	UE2T45	UE2T44	UE2T43	UE2T42	UE2T41	UE2T40
		Reset:	Unaffected by reset							
\$0035	USB Endpoint 2 Data Register 5 (UE2D5)	Read:	UE2R57	UE2R56	UE2R55	UE2R54	UE2R53	UE2R52	UE2R51	UE2R50
		Write:	UE2T57	UE2T56	UE2T55	UE2T54	UE2T53	UE2T52	UE2T51	UE2T50
		Reset:	Unaffected by reset							
\$0036	USB Endpoint 2 Data Register 6 (UE2D6)	Read:	UE2R67	UE2R66	UE2R65	UE2R64	UE2R63	UE2R62	UE2R61	UE2R60
		Write:	UE2T67	UE2T66	UE2T65	UE2T64	UE2T63	UE2T62	UE2T61	UE2T60
		Reset:	Unaffected by reset							
\$0037	USB Endpoint 2 Data Register 7 (UE2D7)	Read:	UE2R77	UE2R76	UE2R75	UE2R74	UE2R73	UE2R72	UE2R71	UE2R70
		Write:	UE2T77	UE2T76	UE2T75	UE2T74	UE2T73	UE2T72	UE2T71	UE2T70
		Reset:	Unaffected by reset							
\$0038	USB Address Register (UADDR)	Read:	USBEN	UADD6	UADD5	UADD4	UADD3	UADD2	UADD1	UADD0
		Write:								
		Reset:	0*	0	0	0	0	0	0	0

* USBEN bit is reset by POR or LVI reset only.

\$0039	USB Interrupt Register 0 (UIR0)	Read:	EOPIE	SUSPND	TXD2IE	RXD2IE	TXD1IE	0	TXD0IE	RXD0IE
		Write:								
		Reset:	0	0	0	0	0	0	0	0
\$003A	USB Interrupt Register 1 (UIR1)	Read:	EOPF	RSTF	TXD2F	RXD2F	TXD1F	RESUMF	TXD0F	RXD0F
		Write:								
		Reset:	0	0	0	0	0	0	0	0
\$003B	USB Control Register 0 (UCR0)	Read:	T0SEQ	0	TX0E	RX0E	TP0SIZ3	TP0SIZ2	TP0SIZ1	TP0SIZ0
		Write:								
		Reset:	0	0	0	0	0	0	0	0

= Unimplemented
R = Reserved
U = Unaffected by reset

Figure 2-2. Control, Status, and Data Registers (Sheet 6 of 8)

Memory Map

Addr.	Register Name	Bit 7	6	5	4	3	2	1	Bit 0		
\$003C	USB Control Register 1 (UCR1)	Read:	T1SEQ	STALL1	TX1E	FRESUM	TP1SIZ3	TP1SIZ2	TP1SIZ1	TP1SIZ0	
		Write:									
		Reset:	0	0	0	0	0	0	0	0	
\$003D	USB Status Register 0 (USR0)	Read:	R0SEQ	SETUP	0	0	RP0SIZ3	RP0SIZ2	RP0SIZ1	RP0SIZ0	
		Write:									
		Reset:	Unaffected by reset								
\$003E	USB Status Register 1 (USR1)	Read:	R2SEQ	TXACK	TXNAK	TXSTL	RP2SIZ3	RP2SIZ2	RP2SIZ1	RP2SIZ0	
		Write:									
		Reset:	U	0	0	0	U	U	U	U	
\$003F	Unimplemented	Read:									
		Write:									
\$FE00	Break Status Register (BSR)	Read:	R	R	R	R	R	R	SBSW	R	
		Write:								See note	
		Reset:	0								
Note: Writing a logic 0 clears SBSW.											
\$FE01	Reset Status Register (RSR)	Read:	POR	PIN	COP	ILOP	ILAD	USB	LVI	0	
		Write:									
		POR:	1	0	0	0	0	0	0	0	0
\$FE02	Reserved	Read:	R	R	R	R	R	R	R	R	
		Write:									
\$FE03	Break Flag Control Register (BFCR)	Read:	BCFE	R	R	R	R	R	R	R	
		Write:									
		Reset:	0								
\$FE04	Interrupt Status Register 1 (INT1)	Read:	IF6	IF5	IF4	IF3	IF2	IF1	0	0	
		Write:	R	R	R	R	R	R	R	R	
		Reset:	0	0	0	0	0	0	0	0	
\$FE05	Reserved	Read:	R	R	R	R	R	R	R	R	
		Write:									
<div style="display: flex; justify-content: space-around; align-items: center;"> <div style="background-color: #cccccc; width: 20px; height: 10px; display: inline-block;"></div> = Unimplemented <div style="border: 1px solid black; padding: 2px 5px; margin-left: 20px;">R</div> = Reserved <div style="margin-left: 20px;">U = Unaffected by reset</div> </div>											

Figure 2-2. Control, Status, and Data Registers (Sheet 7 of 8)

Addr.	Register Name	Bit 7	6	5	4	3	2	1	Bit 0	
\$FE06	Reserved	Read:								
		Write:	R	R	R	R	R	R	R	R
\$FE07	Reserved	Read:								
		Write:	R	R	R	R	R	R	R	R
\$FE08	FLASH Control Register (FLCR)	Read:	0	0	0	0	HVEN	MASS	ERASE	PGM
		Write:	[Unimplemented]							
		Reset:	0	0	0	0	0	0	0	0
\$FE09	FLASH Block Protect Register (FLBPR)	Read:								
		Write:	BPR7	BPR6	BPR5	BPR4	BPR3	BPR2	BPR1	BPR0
		Reset:	0	0	0	0	0	0	0	0
\$FE0A	Reserved	Read:								
		Write:	R	R	R	R	R	R	R	R
\$FE0B	Reserved	Read:								
		Write:	R	R	R	R	R	R	R	R
\$FE0C	Break Address High Register (BRKH)	Read:								
		Write:	Bit15	Bit14	Bit13	Bit12	Bit11	Bit10	Bit9	Bit8
		Reset:	0	0	0	0	0	0	0	0
\$FE0D	Break Address low Register (BRKL)	Read:								
		Write:	Bit7	Bit6	Bit5	Bit4	Bit3	Bit2	Bit1	Bit0
		Reset:	0	0	0	0	0	0	0	0
\$FE0E	Break Status and Control Register (BRKSCR)	Read:			0	0	0	0	0	0
		Write:	BRKE	BRKA	[Unimplemented]					
		Reset:	0	0	0	0	0	0	0	0
\$FFFF	COP Control Register (COPCTL)	Read:	Low byte of reset vector							
		Write:	Writing clears COP counter (any value)							
		Reset:	Unaffected by reset							

= Unimplemented
R = Reserved
U = Unaffected by reset

Figure 2-2. Control, Status, and Data Registers (Sheet 8 of 8)

Table 2-1 is a list of vector locations.

Table 2-1. Vector Addresses

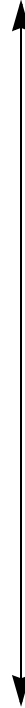
Vector Priority	INT Flag	Address	Vector
Lowest  Highest	IF6	\$FFF0	Keyboard Vector (High)
		\$FFF1	Keyboard Vector (Low)
	IF5	\$FFF2	TIM Overflow Vector (High)
		\$FFF3	TIM Overflow Vector (Low)
	IF4	\$FFF4	TIM Channel 1 Vector (High)
		\$FFF5	TIM Channel 1 Vector (Low)
	IF3	\$FFF6	TIM Channel 0 Vector (High)
		\$FFF7	TIM Channel 0 Vector (Low)
	IF1	\$FFF8	IRQ Vector (High)
		\$FFF9	IRQ Vector (Low)
	IF2	\$FFFA	USB Vector (High)
		\$FFFFB	USB Vector (Low)
	—	\$FFFC	SWI Vector (High)
		\$FFFD	SWI Vector (Low)
	—	\$FFFE	Reset Vector (High)
		\$FFFF	Reset Vector (Low)

Section 3. Random-Access Memory (RAM)

3.1 Contents

3.2	Introduction	51
3.3	Functional Description	51

3.2 Introduction

This section describes the 256 bytes of RAM.

3.3 Functional Description

Addresses \$0040–\$013F are RAM locations. The location of the stack RAM is programmable. The 16-bit stack pointer allows the stack to be anywhere in the 64-Kbyte memory space.

NOTE: *For correct operation, the stack pointer must point only to RAM locations.*

Within page zero are 192 bytes of RAM. Because the location of the stack RAM is programmable, all page zero RAM locations can be used for I/O control and user data or code. When the stack pointer is moved from its reset location at \$00FF, direct addressing mode instructions can access efficiently all page zero RAM locations. Page zero RAM, therefore, provides ideal locations for frequently accessed global variables.

Before processing an interrupt, the CPU uses five bytes of the stack to save the contents of the CPU registers.

NOTE: *For M6805 Family compatibility, the H register is not stacked.*

During a subroutine call, the CPU uses two bytes of the stack to store the return address. The stack pointer decrements during pushes and increments during pulls.

NOTE: *Be careful when using nested subroutines. The CPU may overwrite data in the RAM during a subroutine or during the interrupt stacking operation.*

Section 4. FLASH Memory

4.1 Contents

4.2	Introduction	53
4.3	Functional Description	54
4.4	FLASH Control Register	55
4.5	FLASH Block Erase Operation	56
4.6	FLASH Mass Erase Operation	57
4.7	FLASH Program Operation	58
4.8	FLASH Protection	60
4.8.1	FLASH Block Protect Register	60
4.9	ROM-Resident Routines	61
4.9.1	Variables	62
4.9.2	ERASE Routine	62
4.9.3	PROGRAM Routine	63
4.9.4	VERIFY Routine	63

4.2 Introduction

This section describes the operation of the embedded FLASH memory. This memory can be read, programmed, and erased from a single external supply. The program and erase operations are enabled through the use of an internal charge pump.

Addr.	Register Name		Bit 7	6	5	4	3	2	1	Bit 0
\$FE08	FLASH Control Register (FLCR)	Read:	0	0	0	0	HVEN	MASS	ERASE	PGM
		Write:								
		Reset:	0	0	0	0	0	0	0	0
\$FE09	FLASH Block Protect Register (FLBPR)	Read:	BPR7	BPR6	BPR5	BPR4	BPR3	BPR2	BPR1	BPR0
		Write:								
		Reset:	0	0	0	0	0	0	0	0

Figure 4-1. FLASH Memory Register Summary

4.3 Functional Description

The FLASH memory consists of an array of 8,192 bytes for user memory plus a small block of 16 bytes for user interrupt vectors. *An erased bit reads as logic 1 and a programmed bit reads as a logic 0.* The FLASH memory is block erasable. The minimum erase block size is 512 bytes. Program and erase operation operations are facilitated through control bits in FLASH control register (FLCR). The address ranges for the FLASH memory are shown as follows:

- \$DC00–\$FBFF (user memory; 8,192 bytes)
- \$FFF0–\$FFFF (user interrupt vectors; 16 bytes)

Programming tools are available from Freescale. Contact your local Freescale representative for more information.

NOTE: *A security feature prevents viewing of the FLASH contents.¹*

1. No security feature is absolutely secure. However, Freescale’s strategy is to make reading or copying the FLASH difficult for unauthorized users.

4.4 FLASH Control Register

The FLASH control register (FLCR) controls FLASH program and erase operations.

Address: \$FE08

	Bit 7	6	5	4	3	2	1	Bit 0
Read:	0	0	0	0	HVEN	MASS	ERASE	PGM
Write:								
Reset:	0	0	0	0	0	0	0	0

Figure 4-2. FLASH Control Register (FLCR)

HVEN — High Voltage Enable Bit

This read/write bit enables high voltage from the charge pump to the memory for either program or erase operation. It can only be set if either PGM or ERASE is high and the sequence for erase or program/verify is followed.

- 1 = High voltage enabled to array and charge pump on
- 0 = High voltage disabled to array and charge pump off

MASS — Mass Erase Control Bit

This read/write bit configures the memory for mass erase operation or block erase operation when the ERASE bit is set.

- 1 = Mass Erase operation selected
- 0 = Block Erase operation selected

ERASE — Erase Control Bit

This read/write bit configures the memory for erase operation. This bit and the PGM bit should not be set to 1 at the same time.

- 1 = Erase operation selected
- 0 = Erase operation not selected

PGM — Program Control Bit

This read/write bit configures the memory for program operation. This bit and the ERASE bit should not be set to 1 at the same time.

- 1 = Program operation selected
- 0 = Program operation not selected

4.5 FLASH Block Erase Operation

Use the following procedure to erase a block of FLASH memory. A block consists of 512 consecutive bytes starting from addresses \$X000, \$X200, \$X400, \$X600, \$X800, \$XA00, \$XC00 or \$XE00. Any block within the 8,192 bytes user memory area (\$DC00–\$FBFF) can be erased alone.

NOTE: *The 16-byte user vectors, \$FFF0–\$FFFF, cannot be erased by the block erase operation because of security reasons. Mass erase is required to erase this block.*

1. Set the ERASE bit and clear the MASS bit in the FLASH control register.
2. Write any data to any FLASH address within the address range of the block to be erased.
3. Wait for a time, t_{nvs} (5 μ s).
4. Set the HVEN bit.
5. Wait for a time t_{erase} (2 ms).
6. Clear the ERASE bit.
7. Wait for a time, t_{nvh} (5 μ s).
8. Clear the HVEN bit.
9. After time, t_{rcv} (1 μ s), the memory can be accessed in read mode again.

NOTE: *Programming and erasing of FLASH locations cannot be performed by code being executed from the FLASH memory. While these operations must be performed in the order as shown, but other unrelated operations may occur between the steps.*

4.6 FLASH Mass Erase Operation

Use the following procedure to erase the entire FLASH memory:

1. Set both the ERASE bit and the MASS bit in the FLASH control register.
2. Write any data to any FLASH address within the address range \$FFE0–\$FFFF.
3. Wait for a time, t_{nvs} (5 μ s).
4. Set the HVEN bit.
5. Wait for a time t_{me} (2 ms).
6. Clear the ERASE bit.
7. Wait for a time, t_{nvh1} (100 μ s).
8. Clear the HVEN bit.
9. After time, t_{rcv} (1 μ s), the memory can be accessed in read mode again.

NOTE: *Programming and erasing of FLASH locations cannot be performed by code being executed from the FLASH memory. While these operations must be performed in the order as shown, but other unrelated operations may occur between the steps.*

4.7 FLASH Program Operation

Programming of the FLASH memory is done on a row basis. A row consists of 64 consecutive bytes starting from addresses \$XX00, \$XX40, \$XX80 or \$XXC0. The procedure for programming a row of the FLASH memory is outlined below:

1. Set the PGM bit. This configures the memory for program operation and enables the latching of address and data for programming.
2. Write any data to any FLASH address within the address range of the row to be programmed.
3. Wait for a time, t_{nvs} (5 μ s).
4. Set the HVEN bit.
5. Wait for a time, t_{pgs} (10 μ s).
6. Write data to the byte being programmed.
7. Wait for time, t_{PROG} (20 μ s).
8. Repeat step 6 and 7 until all the bytes within the row are programmed.
9. Clear the PGM bit.
10. Wait for time, t_{nvh} (5 μ s).
11. Clear the HVEN bit.
12. After time, t_{rcv} (1 μ s), the memory can be accessed in read mode again.

This program sequence is repeated throughout the memory until all data is programmed.

NOTE: *Programming and erasing of FLASH locations cannot be performed by code being executed from the FLASH memory. While these operations must be performed in the order shown, other unrelated operations may occur between the steps. Do not exceed t_{PROG} maximum (see [18.13 Memory Characteristics](#)).*

Figure 4-3 shows a flowchart representation for programming the FLASH memory.

**Algorithm for programming
a row (64 bytes) of FLASH memory**

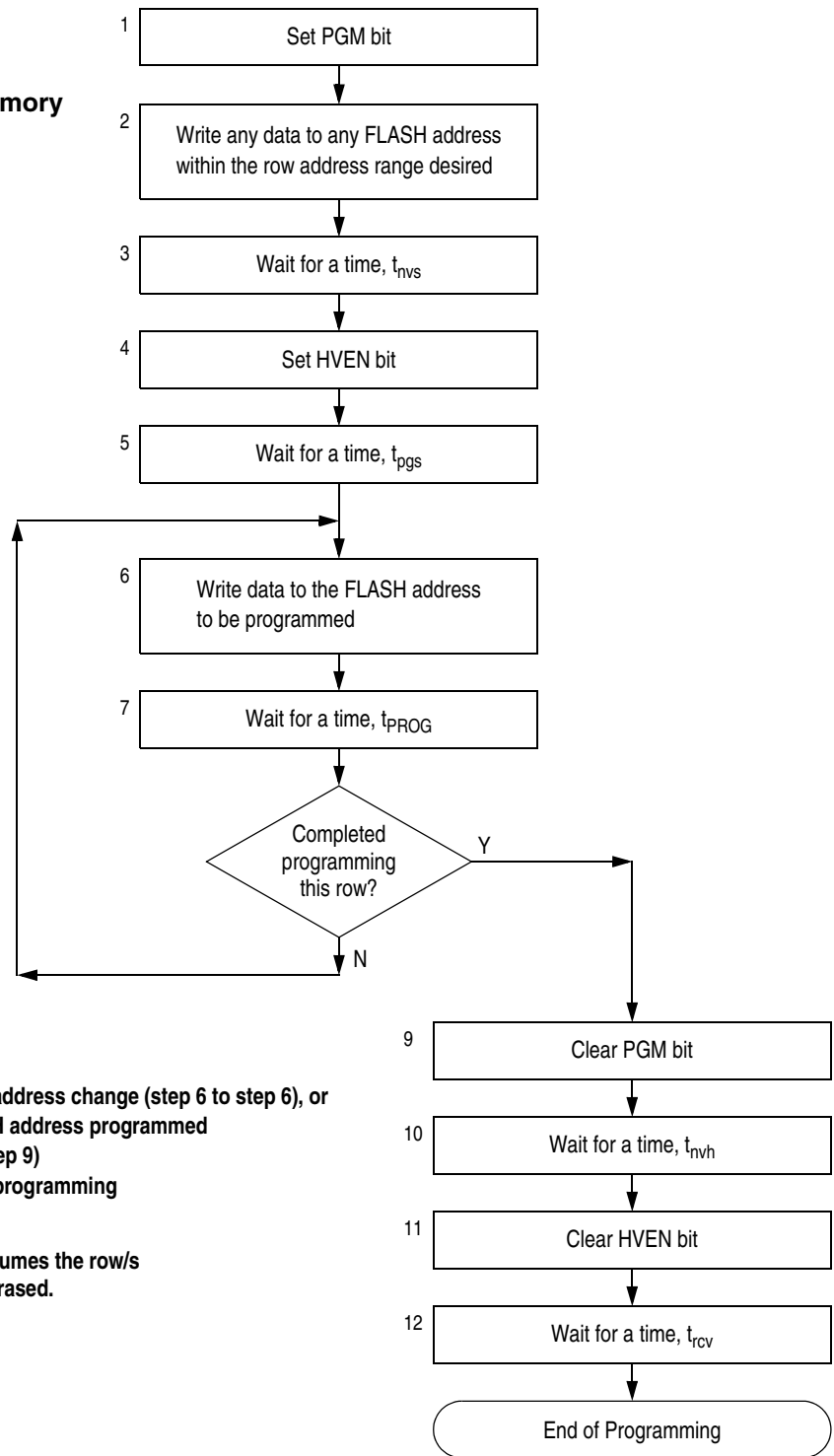

NOTE:

The time between each FLASH address change (step 6 to step 6), or the time between the last FLASH address programmed to clearing PGM bit (step 6 to step 9) must not exceed the maximum programming time, $t_{\text{PROG max}}$.

This row program algorithm assumes the row/s to be programmed are initially erased.

Figure 4-3. FLASH Programming Flowchart

4.8 FLASH Protection

Due to the ability of the on-board charge pump to erase and program the FLASH memory in the target application, provision is made to protect blocks of memory from unintentional erase or program operations due to system malfunction. This protection is done by use of a FLASH block protect register (FLBPR). The FLBPR determines the range of the FLASH memory which is to be protected. The range of the protected area starts from a location defined by FLBPR and ends to the bottom of the FLASH memory (\$FFFF). When the memory is protected, the HVEN bit cannot be set in either ERASE or PROGRAM operations.

NOTE: *When the FLBPR is cleared (all 0's), the entire FLASH memory is protected from being programmed and erased. When all the bits are set, the entire FLASH memory is accessible for program and erase.*

4.8.1 FLASH Block Protect Register

The FLASH block protect register is implemented as an 8-bit I/O register. The content of this register determine the starting location of the protected range within the FLASH memory.

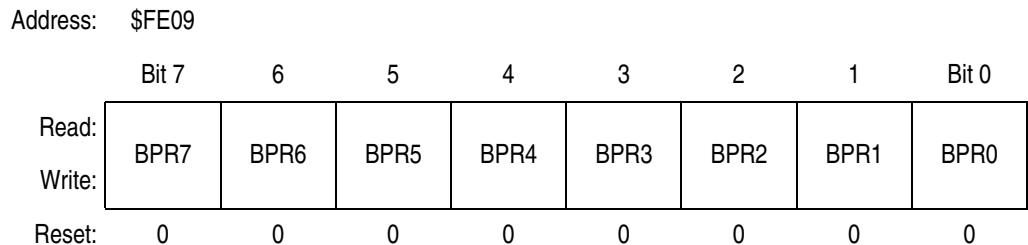

Figure 4-4. FLASH Block Protect Register (FLBPR)

BPR[7:0] — FLASH Block Protect Register Bit 7 to Bit 0

BPR[7:1] represent bits [15:9] of a 16-bit memory address; bits [8:0] are logic 0's.

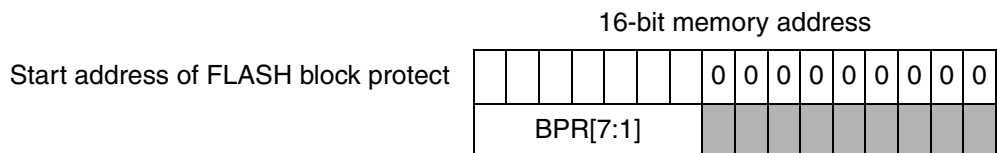

Figure 4-5. FLASH Block Protect Start Address

BPR0 is used only for BPR[7:0] = \$FF, for no block protection.

The resultant 16-bit address is used for specifying the start address of the FLASH memory for block protection. The FLASH is protected from this start address to the end of FLASH memory, at \$FFFF. With this mechanism, the protect start address can be X000, X200, X400, X600, X800, XA00, XC00, or XE00 within the FLASH memory.

Examples of protect start address:

BPR[7:0]	Start of Address of Protect Range
\$00 to \$DC	The entire FLASH memory is protected.
\$DE (1101 1110)	\$DE00 (1101 1110 0000 0000)
\$E0 (1110 0000)	\$E000 (1110 0000 0000 0000)
\$E2 (1110 0010)	\$E200 (1110 0010 0000 0000)
\$E4 (1110 0100)	\$E400 (1110 0100 0000 0000)
and so on...	
\$FE	\$FFE0–\$FFFF (User vectors)
\$FF	The entire FLASH memory is not protected.

Note:

The end address of the protected range is always \$FFFF.

4.9 ROM-Resident Routines

ROM-resident routines can be called by a program running in user mode or in monitor mode (see [Section 10. Monitor ROM \(MON\)](#)) for FLASH programming, erasing, and verifying. The range of the FLASH memory must be unprotected (see [4.8 FLASH Protection](#)) before calling the erase or programming routine.

Table 4-1. ROM-Resident Routines

Routine Name	Call Address	Routine Function
VERIFY	\$FC03	FLASH verify routine
ERASE	\$FC06	FLASH mass erase routine
PROGRAM	\$FC09	FLASH program routine

4.9.1 Variables

The ROM-resident routines use three variables: CTRLBYT, CPUSPD and LADDR; and one data buffer. The minimum size of the data buffer is one byte and the maximum size is 64 bytes.

CPUSPD must be set before calling the ERASE or PROGRAM routine, and should be set to four times the value of the CPU internal bus speed in MHz. For example: for CPU speed of 3MHz, CPUSPD should be set to 12.

Table 4-2. ROM-Resident Routine Variables

Variable	Address	Description
CTRLBYT	\$0048	Control byte for setting mass erase.
CPUSPD	\$0049	Timing adjustment for different CPU speeds.
LADDR	\$004A–\$004B	Last FLASH address to be programmed.
DATABUF	\$004C–\$008B	Data buffer for programming and verifying.

4.9.2 ERASE Routine

The ERASE routine erases the entire FLASH memory. The routine does not check for a blank range before or after erase.

Table 4-3. ERASE Routine

Routine	ERASE
Calling Address	\$FC06
Stack Use	5 Bytes
Input	CPUSPD — CPU speed HX — Contains any address in the range to be erased CTRLBYT — Mass erase Mass erase if bit 6 = 1

4.9.3 PROGRAM Routine

The PROGRAM routine programs a range of addresses in FLASH memory, which does not have to be on page boundaries, either at the begin or end address.

Table 4-4. PROGRAM Routine

Routine	PROGRAM
Calling Address	\$FC09
Stack Use	7 Bytes
Input	CPUSPD — CPU speed HX — FLASH start address to be programmed LADDR — FLASH end address to be programmed DATABUF — Contains the data to be programmed

4.9.4 VERIFY Routine

The VERIFY routine reads and verifies a range of FLASH memory.

Table 4-5. VERIFY Routine

Routine	VERIFY
Calling Address	\$FC03
Stack Use	6 Bytes
Input	HX — FLASH start address to be verified LADDR — FLASH end address to be verified DATABUF — Contains the data to be verified
Output	C Bit — C bit is set if verify passes DATABUF — Contains the data in the range of the FLASH memory



Section 5. Configuration Register (CONFIG)

5.1 Contents

5.2	Introduction	65
5.3	Functional Description	66

5.2 Introduction

This section describes the configuration register (CONFIG). This write-once-after-reset register controls the following options:

- USB reset
- Low voltage inhibit
- Stop mode recovery time (2048 or 4096 OSCXCLK cycles)
- COP timeout period ($2^{18} - 2^4$ or $2^{13} - 2^4$ OSCXCLK cycles)
- STOP instruction
- Computer operating properly module (COP)

5.3 Functional Description

The configuration register is used in the initialization of various options. The configuration register can be written once after each reset. Bit-5 and bit-4 are cleared by a POR or LVI reset only. Bit-3 to bit-0 are cleared during any reset. Since the various options affect the operation of the MCU, it is recommended that this register be written immediately after reset. The configuration register is located at \$001F. The configuration register may be read at any time.

Address: \$001F

	Bit 7	6	5	4	3	2	1	Bit 0
Read:	0	0	URSTD	LVID	SSREC	COPRS	STOP	COPD
Write:								
Reset:	0	0	0*	0*	0	0	0	0

= Unimplemented

* URSTD and LVID bits are reset by POR or LVI reset only.

Figure 5-1. Configuration Register (CONFIG)

URSTD — USB Reset Disable Bit

URSTD disables the USB reset signal generating an internal reset to the CPU and internal registers. Instead, it will generate an interrupt request to the CPU.

- 1 = USB reset generates a USB interrupt request to CPU
- 0 = USB reset generates a chip reset

LVID — Low Voltage Inhibit Disable Bit

LVID disables the LVI circuit

- 1 = Disable LVI circuit
- 0 = Enable LVI circuit

SSREC — Short Stop Recovery Bit

SSREC enables the CPU to exit stop mode with a delay of $2048 \times \text{OSCCLK}$ cycles instead of a $4096 \times \text{OSCCLK}$ cycle delay.

- 1 = Stop mode recovery after $2048 \times \text{OSCCLK}$ cycles
- 0 = Stop mode recovery after $4096 \times \text{OSCCLK}$ cycles

NOTE: *Exiting stop mode by pulling reset will result in the long stop recovery. If using an external crystal, do not set the SSREC bit.*

COPRS — COP Rate Select Bit

COPD selects the COP timeout period. Reset clears COPRS. (See [Section 15. Computer Operating Properly \(COP\)](#).)

1 = COP timeout period = $(2^{13} - 2^4) \times \text{OSCXCLK}$ cycles

0 = COP timeout period = $(2^{18} - 2^4) \times \text{OSCXCLK}$ cycles

STOP — STOP Instruction Enable Bit

STOP enables the STOP instruction.

1 = STOP instruction enabled

0 = STOP instruction treated as illegal opcode

COPD — COP Disable Bit

COPD disables the COP module. (See [Section 15. Computer Operating Properly \(COP\)](#).)

1 = COP module disabled

0 = COP module enabled



Configuration Register (CONFIG)

Section 6. Central Processor Unit (CPU)

6.1 Contents

6.2	Introduction	70
6.3	Features	70
6.4	CPU Registers	71
6.4.1	Accumulator	71
6.4.2	Index Register	72
6.4.3	Stack Pointer	72
6.4.4	Program Counter	73
6.4.5	Condition Code Register	74
6.5	Arithmetic/Logic Unit (ALU)	76
6.6	Low-Power Modes	76
6.6.1	Wait Mode	76
6.6.2	Stop Mode	77
6.7	CPU During Break Interrupts	77
6.8	Instruction Set Summary	78
6.9	Opcode Map	86

6.2 Introduction

The M68HC08 CPU (central processor unit) is an enhanced and fully object-code-compatible version of the M68HC05 CPU. The *CPU08 Reference Manual* (Freescale document order number CPU08RM/AD) contains a description of the CPU instruction set, addressing modes, and architecture.

6.3 Features

- Object code fully upward-compatible with M68HC05 Family
- 16-bit stack pointer with stack manipulation instructions
- 16-bit index register with x-register manipulation instructions
- 3-MHz CPU internal bus frequency
- 64-Kbyte program/data memory space
- 16 addressing modes
- Memory-to-memory data moves without using accumulator
- Fast 8-bit by 8-bit multiply and 16-bit by 8-bit divide instructions
- Enhanced binary-coded decimal (BCD) data handling
- Modular architecture with expandable internal bus definition for extension of addressing range beyond 64-Kbytes
- Low-power stop and wait modes

6.4 CPU Registers

Figure 6-1 shows the five CPU registers. CPU registers are not part of the memory map.

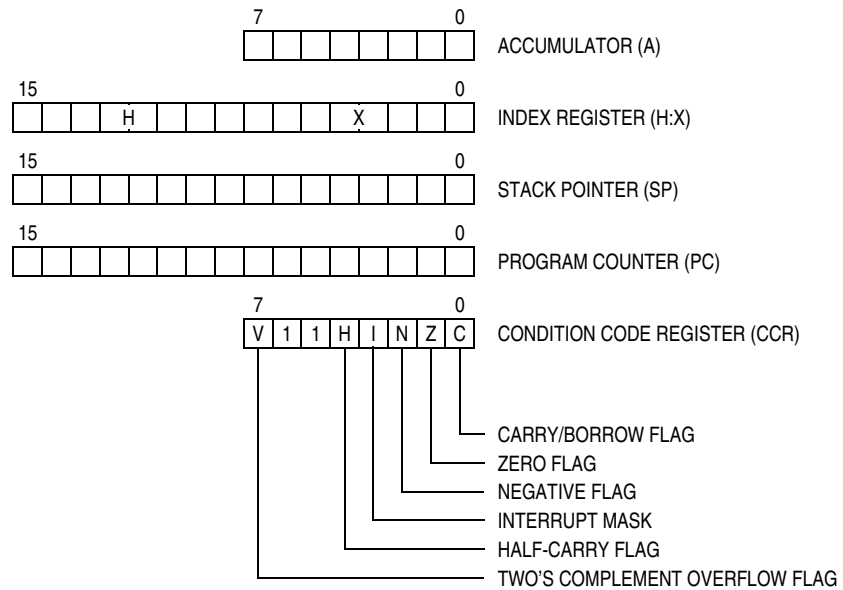

Figure 6-1. CPU Registers

6.4.1 Accumulator

The accumulator is a general-purpose 8-bit register. The CPU uses the accumulator to hold operands and the results of arithmetic/logic operations.

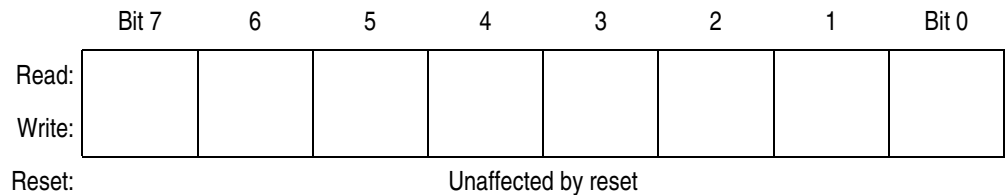

Figure 6-2. Accumulator (A)

6.4.2 Index Register

The 16-bit index register allows indexed addressing of a 64-Kbyte memory space. H is the upper byte of the index register, and X is the lower byte. H:X is the concatenated 16-bit index register.

In the indexed addressing modes, the CPU uses the contents of the index register to determine the conditional address of the operand.

The index register can serve also as a temporary data storage location.

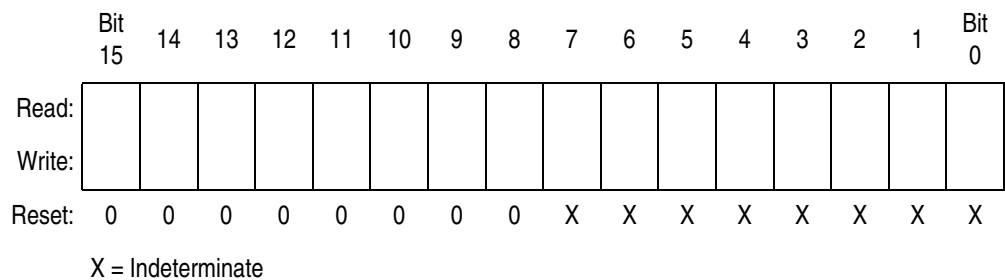

Figure 6-3. Index Register (H:X)

6.4.3 Stack Pointer

The stack pointer is a 16-bit register that contains the address of the next location on the stack. During a reset, the stack pointer is preset to \$00FF. The reset stack pointer (RSP) instruction sets the least significant byte to \$FF and does not affect the most significant byte. The stack pointer decrements as data is pushed onto the stack and increments as data is pulled from the stack.

In the stack pointer 8-bit offset and 16-bit offset addressing modes, the stack pointer can function as an index register to access data on the stack. The CPU uses the contents of the stack pointer to determine the conditional address of the operand.

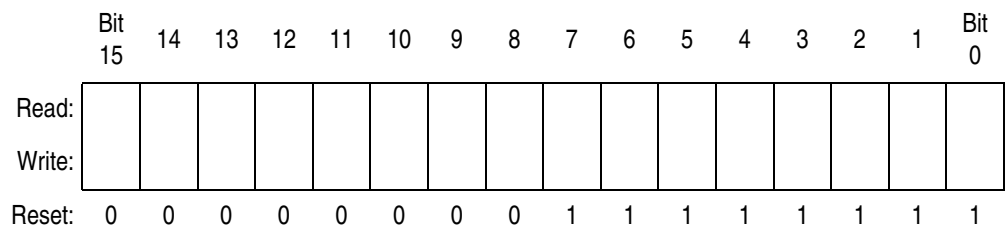

Figure 6-4. Stack Pointer (SP)

NOTE: *The location of the stack is arbitrary and may be relocated anywhere in RAM. Moving the SP out of page 0 (\$0000 to \$00FF) frees direct address (page 0) space. For correct operation, the stack pointer must point only to RAM locations.*

6.4.4 Program Counter

The program counter is a 16-bit register that contains the address of the next instruction or operand to be fetched.

Normally, the program counter automatically increments to the next sequential memory location every time an instruction or operand is fetched. Jump, branch, and interrupt operations load the program counter with an address other than that of the next sequential location.

During reset, the program counter is loaded with the reset vector address located at \$FFFE and \$FFFF. The vector address is the address of the first instruction to be executed after exiting the reset state.

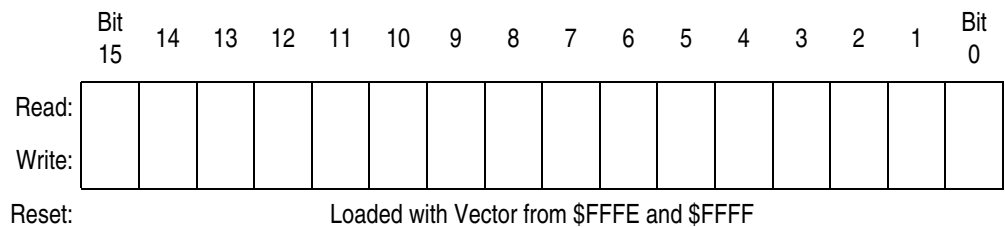

Figure 6-5. Program Counter (PC)

6.4.5 Condition Code Register

The 8-bit condition code register contains the interrupt mask and five flags that indicate the results of the instruction just executed. Bits 6 and 5 are set permanently to logic 1. The following paragraphs describe the functions of the condition code register.

	Bit 7	6	5	4	3	2	1	Bit 0
Read:	V	1	1	H	I	N	Z	C
Write:								
Reset:	X	1	1	X	1	X	X	X

X = Indeterminate

Figure 6-6. Condition Code Register (CCR)

V — Overflow Flag

The CPU sets the overflow flag when a two's complement overflow occurs. The signed branch instructions BGT, BGE, BLE, and BLT use the overflow flag.

1 = Overflow

0 = No overflow

H — Half-Carry Flag

The CPU sets the half-carry flag when a carry occurs between accumulator bits 3 and 4 during an add-without-carry (ADD) or add-with-carry (ADC) operation. The half-carry flag is required for binary-coded decimal (BCD) arithmetic operations. The DAA instruction uses the states of the H and C flags to determine the appropriate correction factor.

1 = Carry between bits 3 and 4

0 = No carry between bits 3 and 4

I — Interrupt Mask

When the interrupt mask is set, all maskable CPU interrupts are disabled. CPU interrupts are enabled when the interrupt mask is cleared. When a CPU interrupt occurs, the interrupt mask is set automatically after the CPU registers are saved on the stack, but before the interrupt vector is fetched.

1 = Interrupts disabled

0 = Interrupts enabled

NOTE: *To maintain M6805 Family compatibility, the upper byte of the index register (H) is not stacked automatically. If the interrupt service routine modifies H, then the user must stack and unstack H using the PSHH and PULH instructions.*

After the I bit is cleared, the highest-priority interrupt request is serviced first.

A return-from-interrupt (RTI) instruction pulls the CPU registers from the stack and restores the interrupt mask from the stack. After any reset, the interrupt mask is set and can be cleared only by the clear interrupt mask software instruction (CLI).

N — Negative flag

The CPU sets the negative flag when an arithmetic operation, logic operation, or data manipulation produces a negative result, setting bit 7 of the result.

1 = Negative result

0 = Non-negative result

Z — Zero flag

The CPU sets the zero flag when an arithmetic operation, logic operation, or data manipulation produces a result of \$00.

1 = Zero result

0 = Non-zero result

C — Carry/Borrow Flag

The CPU sets the carry/borrow flag when an addition operation produces a carry out of bit 7 of the accumulator or when a subtraction operation requires a borrow. Some instructions — such as bit test and branch, shift, and rotate — also clear or set the carry/borrow flag.

1 = Carry out of bit 7

0 = No carry out of bit 7

6.5 Arithmetic/Logic Unit (ALU)

The ALU performs the arithmetic and logic operations defined by the instruction set.

Refer to the *CPU08 Reference Manual* (Freescale document order number CPU08RM/AD) for a description of the instructions and addressing modes and more detail about the architecture of the CPU.

6.6 Low-Power Modes

The WAIT and STOP instructions put the MCU in low power-consumption standby modes.

6.6.1 Wait Mode

The WAIT instruction:

- Clears the interrupt mask (I bit) in the condition code register, enabling interrupts. After exit from wait mode by interrupt, the I bit remains clear. After exit by reset, the I bit is set.
- Disables the CPU clock

6.6.2 Stop Mode

The STOP instruction:

- Clears the interrupt mask (I bit) in the condition code register, enabling external interrupts. After exit from stop mode by external interrupt, the I bit remains clear. After exit by reset, the I bit is set.
- Disables the CPU clock

After exiting stop mode, the CPU clock begins running after the oscillator stabilization delay.

6.7 CPU During Break Interrupts

If a break module is present on the MCU, the CPU starts a break interrupt by:

- Loading the instruction register with the SWI instruction
- Loading the program counter with \$FFFC:\$FFFD or with \$FEFC:\$FEFD in monitor mode

The break interrupt begins after completion of the CPU instruction in progress. If the break address register match occurs on the last cycle of a CPU instruction, the break interrupt begins immediately.

A return-from-interrupt instruction (RTI) in the break routine ends the break interrupt and returns the MCU to normal operation if the break interrupt has been deasserted.

6.8 Instruction Set Summary

Table 6-1. Instruction Set Summary (Sheet 1 of 9)

Source Form	Operation	Description	Effect on CCR						Address Mode	Opcode	Operand	Cycles
			V	H	I	N	Z	C				
ADC #opr ADC opr ADC opr ADC opr,X ADC opr,X ADC ,X ADC opr,SP ADC opr,SP	Add with Carry	$A \leftarrow (A) + (M) + (C)$	↕	↕	–	↕	↕	↕	IMM DIR EXT IX2 IX1 IX SP1 SP2	A9 B9 C9 D9 E9 F9 9EE9 9ED9	ii dd hh ll ee ff ff ff ff ff ff ee ff	2 3 4 4 3 2 4 5
ADD #opr ADD opr ADD opr ADD opr,X ADD opr,X ADD ,X ADD opr,SP ADD opr,SP	Add without Carry	$A \leftarrow (A) + (M)$	↕	↕	–	↕	↕	↕	IMM DIR EXT IX2 IX1 IX SP1 SP2	AB BB CB DB EB FB 9EEB 9EDB	ii dd hh ll ee ff ff ff ff ee ff	2 3 4 4 3 2 4 5
AIS #opr	Add Immediate Value (Signed) to SP	$SP \leftarrow (SP) + (16 \ll M)$	–	–	–	–	–	–	IMM	A7	ii	2
AIX #opr	Add Immediate Value (Signed) to H:X	$H:X \leftarrow (H:X) + (16 \ll M)$	–	–	–	–	–	–	IMM	AF	ii	2
AND #opr AND opr AND opr AND opr,X AND opr,X AND ,X AND opr,SP AND opr,SP	Logical AND	$A \leftarrow (A) \& (M)$	0	–	–	↕	↕	–	IMM DIR EXT IX2 IX1 IX SP1 SP2	A4 B4 C4 D4 E4 F4 9EE4 9ED4	ii dd hh ll ee ff ff ff ff ee ff	2 3 4 4 3 2 4 5
ASL opr ASLA ASLX ASL opr,X ASL ,X ASL opr,SP	Arithmetic Shift Left (Same as LSL)		↕	–	–	↕	↕	↕	DIR INH INH IX1 IX SP1	38 48 58 68 78 9E68	dd dd ff ff ff ff	4 1 1 4 3 5
ASR opr ASRA ASRX ASR opr,X ASR opr,X ASR opr,SP	Arithmetic Shift Right		↕	–	–	↕	↕	↕	DIR INH INH IX1 IX SP1	37 47 57 67 77 9E67	dd dd ff ff ff ff	4 1 1 4 3 5

Table 6-1. Instruction Set Summary (Sheet 2 of 9)

Source Form	Operation	Description	Effect on CCR						Address Mode	Opcode	Operand	Cycles
			V	H	I	N	Z	C				
BCC <i>rel</i>	Branch if Carry Bit Clear	$PC \leftarrow (PC) + 2 + rel ? (C) = 0$	-	-	-	-	-	-	REL	24	rr	3
BCLR <i>n, opr</i>	Clear Bit <i>n</i> in <i>M</i>	$Mn \leftarrow 0$							DIR (b0)	11	dd	4
									DIR (b1)	13	dd	4
									DIR (b2)	15	dd	4
									DIR (b3)	17	dd	4
									DIR (b4)	19	dd	4
									DIR (b5)	1B	dd	4
									DIR (b6)	1D	dd	4
						DIR (b7)	1F	dd	4			
BCS <i>rel</i>	Branch if Carry Bit Set (Same as BLO)	$PC \leftarrow (PC) + 2 + rel ? (C) = 1$	-	-	-	-	-	-	REL	25	rr	3
BEQ <i>rel</i>	Branch if Equal	$PC \leftarrow (PC) + 2 + rel ? (Z) = 1$	-	-	-	-	-	-	REL	27	rr	3
BGE <i>opr</i>	Branch if Greater Than or Equal To (Signed Operands)	$PC \leftarrow (PC) + 2 + rel ? (N \oplus V) = 0$	-	-	-	-	-	-	REL	90	rr	3
BGT <i>opr</i>	Branch if Greater Than (Signed Operands)	$PC \leftarrow (PC) + 2 + rel ? (Z) \mid (N \oplus V) = 0$	-	-	-	-	-	-	REL	92	rr	3
BHCC <i>rel</i>	Branch if Half Carry Bit Clear	$PC \leftarrow (PC) + 2 + rel ? (H) = 0$	-	-	-	-	-	-	REL	28	rr	3
BHCS <i>rel</i>	Branch if Half Carry Bit Set	$PC \leftarrow (PC) + 2 + rel ? (H) = 1$	-	-	-	-	-	-	REL	29	rr	3
BHI <i>rel</i>	Branch if Higher	$PC \leftarrow (PC) + 2 + rel ? (C) \mid (Z) = 0$	-	-	-	-	-	-	REL	22	rr	3
BHS <i>rel</i>	Branch if Higher or Same (Same as BCC)	$PC \leftarrow (PC) + 2 + rel ? (C) = 0$	-	-	-	-	-	-	REL	24	rr	3
BIH <i>rel</i>	Branch if \overline{IRQ} Pin High	$PC \leftarrow (PC) + 2 + rel ? \overline{IRQ} = 1$	-	-	-	-	-	-	REL	2F	rr	3
BIL <i>rel</i>	Branch if \overline{IRQ} Pin Low	$PC \leftarrow (PC) + 2 + rel ? \overline{IRQ} = 0$	-	-	-	-	-	-	REL	2E	rr	3
BIT # <i>opr</i> BIT <i>opr</i> BIT <i>opr</i> BIT <i>opr,X</i> BIT <i>opr,X</i> BIT , <i>X</i> BIT <i>opr,SP</i> BIT <i>opr,SP</i>	Bit Test	(A) & (M)	0	-	-	↕	↕	-	IMM DIR EXT IX2 IX1 IX SP1 SP2	A5 B5 C5 D5 E5 F5 9EE5 9ED5	ii dd hh ll ee ff ff ff ee ff	2 3 4 4 3 2 4 5
BLE <i>opr</i>	Branch if Less Than or Equal To (Signed Operands)	$PC \leftarrow (PC) + 2 + rel ? (Z) \mid (N \oplus V) = 1$	-	-	-	-	-	-	REL	93	rr	3
BLO <i>rel</i>	Branch if Lower (Same as BCS)	$PC \leftarrow (PC) + 2 + rel ? (C) = 1$	-	-	-	-	-	-	REL	25	rr	3
BLS <i>rel</i>	Branch if Lower or Same	$PC \leftarrow (PC) + 2 + rel ? (C) \mid (Z) = 1$	-	-	-	-	-	-	REL	23	rr	3
BLT <i>opr</i>	Branch if Less Than (Signed Operands)	$PC \leftarrow (PC) + 2 + rel ? (N \oplus V) = 1$	-	-	-	-	-	-	REL	91	rr	3
BMC <i>rel</i>	Branch if Interrupt Mask Clear	$PC \leftarrow (PC) + 2 + rel ? (I) = 0$	-	-	-	-	-	-	REL	2C	rr	3
BMI <i>rel</i>	Branch if Minus	$PC \leftarrow (PC) + 2 + rel ? (N) = 1$	-	-	-	-	-	-	REL	2B	rr	3
BMS <i>rel</i>	Branch if Interrupt Mask Set	$PC \leftarrow (PC) + 2 + rel ? (I) = 1$	-	-	-	-	-	-	REL	2D	rr	3

Table 6-1. Instruction Set Summary (Sheet 3 of 9)

Source Form	Operation	Description	Effect on CCR						Address Mode	Opcode	Operand	Cycles
			V	H	I	N	Z	C				
BNE <i>rel</i>	Branch if Not Equal	$PC \leftarrow (PC) + 2 + rel ? (Z) = 0$	-	-	-	-	-	-	REL	26	rr	3
BPL <i>rel</i>	Branch if Plus	$PC \leftarrow (PC) + 2 + rel ? (N) = 0$	-	-	-	-	-	-	REL	2A	rr	3
BRA <i>rel</i>	Branch Always	$PC \leftarrow (PC) + 2 + rel$	-	-	-	-	-	-	REL	20	rr	3
BRCLR <i>n,opr,rel</i>	Branch if Bit <i>n</i> in M Clear	$PC \leftarrow (PC) + 3 + rel ? (Mn) = 0$	-	-	-	-	-	↓	DIR (b0)	01	dd rr	5
									DIR (b1)	03	dd rr	5
									DIR (b2)	05	dd rr	5
									DIR (b3)	07	dd rr	5
									DIR (b4)	09	dd rr	5
									DIR (b5)	0B	dd rr	5
									DIR (b6)	0D	dd rr	5
DIR (b7)	0F	dd rr	5									
BRN <i>rel</i>	Branch Never	$PC \leftarrow (PC) + 2$	-	-	-	-	-	-	REL	21	rr	3
BRSET <i>n,opr,rel</i>	Branch if Bit <i>n</i> in M Set	$PC \leftarrow (PC) + 3 + rel ? (Mn) = 1$	-	-	-	-	-	↓	DIR (b0)	00	dd rr	5
									DIR (b1)	02	dd rr	5
									DIR (b2)	04	dd rr	5
									DIR (b3)	06	dd rr	5
									DIR (b4)	08	dd rr	5
									DIR (b5)	0A	dd rr	5
									DIR (b6)	0C	dd rr	5
DIR (b7)	0E	dd rr	5									
BSET <i>n,opr</i>	Set Bit <i>n</i> in M	$Mn \leftarrow 1$	-	-	-	-	-	-	DIR (b0)	10	dd	4
									DIR (b1)	12	dd	4
									DIR (b2)	14	dd	4
									DIR (b3)	16	dd	4
									DIR (b4)	18	dd	4
									DIR (b5)	1A	dd	4
									DIR (b6)	1C	dd	4
DIR (b7)	1E	dd	4									
BSR <i>rel</i>	Branch to Subroutine	$PC \leftarrow (PC) + 2$; push (PCL) $SP \leftarrow (SP) - 1$; push (PCH) $SP \leftarrow (SP) - 1$ $PC \leftarrow (PC) + rel$	-	-	-	-	-	-	REL	AD	rr	4
CBEQ <i>opr,rel</i> CBEQA # <i>opr,rel</i> CBEQX # <i>opr,rel</i> CBEQ <i>opr,X+,rel</i> CBEQ <i>X+,rel</i> CBEQ <i>opr,SP,rel</i>	Compare and Branch if Equal	$PC \leftarrow (PC) + 3 + rel ? (A) - (M) = \00 $PC \leftarrow (PC) + 3 + rel ? (A) - (M) = \00 $PC \leftarrow (PC) + 3 + rel ? (X) - (M) = \00 $PC \leftarrow (PC) + 3 + rel ? (A) - (M) = \00 $PC \leftarrow (PC) + 2 + rel ? (A) - (M) = \00 $PC \leftarrow (PC) + 4 + rel ? (A) - (M) = \00	-	-	-	-	-	-	DIR	31	dd rr	5
									IMM	41	ii rr	4
									IMM	51	ii rr	4
									IX1+	61	ff rr	5
									IX+	71	rr	4
									SP1	9E61	ff rr	6
CLC	Clear Carry Bit	$C \leftarrow 0$	-	-	-	-	-	0	INH	98		1
CLI	Clear Interrupt Mask	$I \leftarrow 0$	-	-	0	-	-	-	INH	9A		2

Table 6-1. Instruction Set Summary (Sheet 4 of 9)

Source Form	Operation	Description	Effect on CCR						Address Mode	Opcode	Operand	Cycles
			V	H	I	N	Z	C				
CLR <i>opr</i> CLRA CLR _X CLR _H CLR <i>opr,X</i> CLR , <i>X</i> CLR <i>opr,SP</i>	Clear	M ← \$00 A ← \$00 X ← \$00 H ← \$00 M ← \$00 M ← \$00 M ← \$00	0	-	-	0	1	-	DIR INH INH INH IX1 IX SP1	3F 4F 5F 8C 6F 7F 9E6F	dd ff ff	3 1 1 1 3 2 4
CMP # <i>opr</i> CMP <i>opr</i> CMP <i>opr</i> CMP <i>opr,X</i> CMP <i>opr,X</i> CMP , <i>X</i> CMP <i>opr,SP</i> CMP <i>opr,SP</i>	Compare A with M	(A) - (M)	⊕	-	-	⊕	⊕	⊕	IMM DIR EXT IX2 IX1 IX SP1 SP2	A1 B1 C1 D1 E1 F1 9EE1 9ED1	ii dd hh ll ee ff ff ff ee ff	2 3 4 4 3 2 4 5
COM <i>opr</i> COMA COM _X COM <i>opr,X</i> COM , <i>X</i> COM <i>opr,SP</i>	Complement (One's Complement)	M ← (M̄) = \$FF - (M) A ← (Ā) = \$FF - (M) X ← (X̄) = \$FF - (M) M ← (M̄) = \$FF - (M) M ← (M̄) = \$FF - (M) M ← (M̄) = \$FF - (M)	0	-	-	⊕	⊕	1	DIR INH INH IX1 IX SP1	33 43 53 63 73 9E63	dd ff ff	4 1 1 4 3 5
CPHX # <i>opr</i> CPHX <i>opr</i>	Compare H:X with M	(H:X) - (M:M + 1)	⊕	-	-	⊕	⊕	⊕	IMM DIR	65 75	ii ii+1 dd	3 4
CPX # <i>opr</i> CPX <i>opr</i> CPX <i>opr</i> CPX , <i>X</i> CPX <i>opr,X</i> CPX <i>opr,X</i> CPX <i>opr,SP</i> CPX <i>opr,SP</i>	Compare X with M	(X) - (M)	⊕	-	-	⊕	⊕	⊕	IMM DIR EXT IX2 IX1 IX SP1 SP2	A3 B3 C3 D3 E3 F3 9EE3 9ED3	ii dd hh ll ee ff ff ff ff ee ff	2 3 4 4 3 2 4 5
DAA	Decimal Adjust A	(A) ₁₀	U	-	-	⊕	⊕	⊕	INH	72		2
DBNZ <i>opr,rel</i> DBNZ _A <i>rel</i> DBNZ _X <i>rel</i> DBNZ <i>opr,X,rel</i> DBNZ , <i>rel</i> DBNZ <i>opr,SP,rel</i>	Decrement and Branch if Not Zero	A ← (A) - 1 or M ← (M) - 1 or X ← (X) - 1 PC ← (PC) + 3 + <i>rel</i> ? (result) ≠ 0 PC ← (PC) + 2 + <i>rel</i> ? (result) ≠ 0 PC ← (PC) + 2 + <i>rel</i> ? (result) ≠ 0 PC ← (PC) + 3 + <i>rel</i> ? (result) ≠ 0 PC ← (PC) + 2 + <i>rel</i> ? (result) ≠ 0 PC ← (PC) + 4 + <i>rel</i> ? (result) ≠ 0	-	-	-	-	-	-	DIR INH INH IX1 IX SP1	3B 4B 5B 6B 7B 9E6B	dd rr rr rr ff rr rr ff rr	5 3 3 5 4 6
DEC <i>opr</i> DECA DEC _X DEC <i>opr,X</i> DEC , <i>X</i> DEC <i>opr,SP</i>	Decrement	M ← (M) - 1 A ← (A) - 1 X ← (X) - 1 M ← (M) - 1 M ← (M) - 1 M ← (M) - 1	⊕	-	-	⊕	⊕	-	DIR INH INH IX1 IX SP1	3A 4A 5A 6A 7A 9E6A	dd ff ff	4 1 1 4 3 5
DIV	Divide	A ← (H:A)/(X) H ← Remainder	-	-	-	-	⊕	⊕	INH	52		7

Table 6-1. Instruction Set Summary (Sheet 5 of 9)

Source Form	Operation	Description	Effect on CCR						Address Mode	Opcode	Operand	Cycles
			V	H	I	N	Z	C				
EOR #opr EOR opr EOR opr EOR opr,X EOR opr,X EOR ,X EOR opr,SP EOR opr,SP	Exclusive OR M with A	$A \leftarrow (A \oplus M)$	0	-	-	↕	↕	-	IMM DIR EXT IX2 IX1 IX SP1 SP2	A8 B8 C8 D8 E8 F8 9EE8 9ED8	ii dd hh ll ee ff ff ff ff ff ee ff	2 3 4 4 3 2 4 5
INC opr INCA INCA INC opr,X INC ,X INC opr,SP INC opr,SP	Increment	$M \leftarrow (M) + 1$ $A \leftarrow (A) + 1$ $X \leftarrow (X) + 1$ $M \leftarrow (M) + 1$ $M \leftarrow (M) + 1$ $M \leftarrow (M) + 1$	↕	-	-	↕	↕	-	DIR INH INH IX1 IX SP1	3C 4C 5C 6C 7C 9E6C	dd ff ff ff	4 1 1 4 3 5
JMP opr JMP opr JMP opr,X JMP opr,X JMP ,X	Jump	$PC \leftarrow \text{Jump Address}$	-	-	-	-	-	-	DIR EXT IX2 IX1 IX	BC CC DC EC FC	dd hh ll ee ff ff	2 3 4 3 2
JSR opr JSR opr JSR opr,X JSR opr,X JSR ,X	Jump to Subroutine	$PC \leftarrow (PC) + n$ ($n = 1, 2, \text{ or } 3$) Push (PCL); $SP \leftarrow (SP) - 1$ Push (PCH); $SP \leftarrow (SP) - 1$ $PC \leftarrow \text{Unconditional Address}$	-	-	-	-	-	-	DIR EXT IX2 IX1 IX	BD CD DD ED FD	dd hh ll ee ff ff	4 5 6 5 4
LDA #opr LDA opr LDA opr LDA opr,X LDA opr,X LDA ,X LDA opr,SP LDA opr,SP	Load A from M	$A \leftarrow (M)$	0	-	-	↕	↕	-	IMM DIR EXT IX2 IX1 IX SP1 SP2	A6 B6 C6 D6 E6 F6 9EE6 9ED6	ii dd hh ll ee ff ff ff ff ee ff	2 3 4 4 3 2 4 5
LDHX #opr LDHX opr	Load H:X from M	$H:X \leftarrow (M:M + 1)$	0	-	-	↕	↕	-	IMM DIR	45 55	ii jj dd	3 4
LDX #opr LDX opr LDX opr LDX opr,X LDX opr,X LDX ,X LDX opr,SP LDX opr,SP	Load X from M	$X \leftarrow (M)$	0	-	-	↕	↕	-	IMM DIR EXT IX2 IX1 IX SP1 SP2	AE BE CE DE EE FE 9EEE 9EDE	ii dd hh ll ee ff ff ff ff ee ff	2 3 4 4 3 2 4 5
LSL opr LSLA LSLX LSL opr,X LSL ,X LSL opr,SP LSL opr,SP	Logical Shift Left (Same as ASL)		↕	-	-	↕	↕	↕	DIR INH INH IX1 IX SP1	38 48 58 68 78 9E68	dd ff ff ff	4 1 1 4 3 5

Table 6-1. Instruction Set Summary (Sheet 6 of 9)

Source Form	Operation	Description	Effect on CCR						Address Mode	Opcode	Operand	Cycles
			V	H	I	N	Z	C				
LSR <i>opr</i> LSRA LSRX LSR <i>opr,X</i> LSR ,X LSR <i>opr,SP</i>	Logical Shift Right		↓	-	-	0	↓	↓	DIR INH IX1 IX SP1	34 44 54 64 74 9E64	dd ff ff	4 1 1 4 3 5
MOV <i>opr,opr</i> MOV <i>opr,X+</i> MOV # <i>opr,opr</i> MOV X+, <i>opr</i>	Move	$(M)_{\text{Destination}} \leftarrow (M)_{\text{Source}}$ $H:X \leftarrow (H:X) + 1 \text{ (IX+D, DIX+)}$	0	-	-	↓	↓	-	DD DIX+ IMD IX+D	4E 5E 6E 7E	dd dd dd ii dd dd	5 4 4 4
MUL	Unsigned multiply	$X:A \leftarrow (X) \times (A)$	-	0	-	-	-	0	INH	42		5
NEG <i>opr</i> NEGA NEGX NEG <i>opr,X</i> NEG ,X NEG <i>opr,SP</i>	Negate (Two's Complement)	$M \leftarrow -(M) = \$00 - (M)$ $A \leftarrow -(A) = \$00 - (A)$ $X \leftarrow -(X) = \$00 - (X)$ $M \leftarrow -(M) = \$00 - (M)$ $M \leftarrow -(M) = \$00 - (M)$	↓	-	-	↓	↓	↓	DIR INH INH IX1 IX SP1	30 40 50 60 70 9E60	dd ff ff	4 1 1 4 3 5
NOP	No Operation	None	-	-	-	-	-	-	INH	9D		1
NSA	Nibble Swap A	$A \leftarrow (A[3:0]:A[7:4])$	-	-	-	-	-	-	INH	62		3
ORA # <i>opr</i> ORA <i>opr</i> ORA <i>opr</i> ORA <i>opr,X</i> ORA <i>opr,X</i> ORA ,X ORA <i>opr,SP</i> ORA <i>opr,SP</i>	Inclusive OR A and M	$A \leftarrow (A) \mid (M)$	0	-	-	↓	↓	-	IMM DIR EXT IX2 IX1 IX SP1 SP2	AA BA CA DA EA FA 9EEA 9EDA	ii dd hh ll ee ff ff ff ff ee ff	2 3 4 4 3 2 4 5
PSHA	Push A onto Stack	Push (A); $SP \leftarrow (SP) - 1$	-	-	-	-	-	-	INH	87		2
PSHH	Push H onto Stack	Push (H); $SP \leftarrow (SP) - 1$	-	-	-	-	-	-	INH	8B		2
PSHX	Push X onto Stack	Push (X); $SP \leftarrow (SP) - 1$	-	-	-	-	-	-	INH	89		2
PULA	Pull A from Stack	$SP \leftarrow (SP + 1)$; Pull (A)	-	-	-	-	-	-	INH	86		2
PULH	Pull H from Stack	$SP \leftarrow (SP + 1)$; Pull (H)	-	-	-	-	-	-	INH	8A		2
PULX	Pull X from Stack	$SP \leftarrow (SP + 1)$; Pull (X)	-	-	-	-	-	-	INH	88		2
ROL <i>opr</i> ROLA ROLX ROL <i>opr,X</i> ROL ,X ROL <i>opr,SP</i>	Rotate Left through Carry		↓	-	-	↓	↓	↓	DIR INH INH IX1 IX SP1	39 49 59 69 79 9E69	dd ff ff	4 1 1 4 3 5

Table 6-1. Instruction Set Summary (Sheet 7 of 9)

Source Form	Operation	Description	Effect on CCR						Address Mode	Opcode	Operand	Cycles
			V	H	I	N	Z	C				
ROR <i>opr</i> RORA RORX ROR <i>opr,X</i> ROR ,X ROR <i>opr,SP</i>	Rotate Right through Carry		↓	-	-	↓	↓	↓	DIR INH INH IX1 IX SP1	36 46 56 66 76 9E66	dd ff ff	4 1 1 4 3 5
RSP	Reset Stack Pointer	SP ← \$FF	-	-	-	-	-	-	INH	9C		1
RTI	Return from Interrupt	SP ← (SP) + 1; Pull (CCR) SP ← (SP) + 1; Pull (A) SP ← (SP) + 1; Pull (X) SP ← (SP) + 1; Pull (PCH) SP ← (SP) + 1; Pull (PCL)	↓	↓	↓	↓	↓	↓	INH	80		7
RTS	Return from Subroutine	SP ← SP + 1; Pull (PCH) SP ← SP + 1; Pull (PCL)	-	-	-	-	-	-	INH	81		4
SBC # <i>opr</i> SBC <i>opr</i> SBC <i>opr</i> SBC <i>opr,X</i> SBC <i>opr,X</i> SBC ,X SBC <i>opr,SP</i> SBC <i>opr,SP</i>	Subtract with Carry	A ← (A) - (M) - (C)	↓	-	-	↓	↓	↓	IMM DIR EXT IX2 IX1 IX SP1 SP2	A2 B2 C2 D2 E2 F2 9EE2 9ED2	ii dd hh ll ee ff ff ff ff ee ff	2 3 4 4 3 2 4 5
SEC	Set Carry Bit	C ← 1	-	-	-	-	-	1	INH	99		1
SEI	Set Interrupt Mask	I ← 1	-	-	1	-	-	-	INH	9B		2
STA <i>opr</i> STA <i>opr</i> STA <i>opr,X</i> STA <i>opr,X</i> STA ,X STA <i>opr,SP</i> STA <i>opr,SP</i>	Store A in M	M ← (A)	0	-	-	↓	↓	-	DIR EXT IX2 IX1 IX SP1 SP2	B7 C7 D7 E7 F7 9EE7 9ED7	dd hh ll ee ff ff ff ff ee ff	3 4 4 3 2 4 5
STHX <i>opr</i>	Store H:X in M	(M:M + 1) ← (H:X)	0	-	-	↓	↓	-	DIR	35	dd	4
STOP	Enable \overline{IRQ} Pin; Stop Oscillator	I ← 0; Stop Oscillator	-	-	0	-	-	-	INH	8E		1
STX <i>opr</i> STX <i>opr</i> STX <i>opr,X</i> STX <i>opr,X</i> STX ,X STX <i>opr,SP</i> STX <i>opr,SP</i>	Store X in M	M ← (X)	0	-	-	↓	↓	-	DIR EXT IX2 IX1 IX SP1 SP2	BF CF DF EF FF 9EEF 9EDF	dd hh ll ee ff ff ff ff ee ff	3 4 4 3 2 4 5

Table 6-1. Instruction Set Summary (Sheet 8 of 9)

Source Form	Operation	Description	Effect on CCR						Address Mode	Opcode	Operand	Cycles
			V	H	I	N	Z	C				
SUB #opr SUB opr SUB opr SUB opr,X SUB opr,X SUB ,X SUB opr,SP SUB opr,SP	Subtract	$A \leftarrow (A) - (M)$	⊕	-	-	⊕	⊕	⊕	IMM DIR EXT IX2 IX1 IX SP1 SP2	A0 B0 C0 D0 E0 F0 9EE0 9ED0	ii dd hh ll ee ff ff ff ff ee ff	2 3 4 4 3 2 4 5
SWI	Software Interrupt	PC ← (PC) + 1; Push (PCL) SP ← (SP) - 1; Push (PCH) SP ← (SP) - 1; Push (X) SP ← (SP) - 1; Push (A) SP ← (SP) - 1; Push (CCR) SP ← (SP) - 1; I ← 1 PCH ← Interrupt Vector High Byte PCL ← Interrupt Vector Low Byte	-	-	1	-	-	-	INH	83		9
TAP	Transfer A to CCR	$CCR \leftarrow (A)$	⊕	⊕	⊕	⊕	⊕	⊕	INH	84		2
TAX	Transfer A to X	$X \leftarrow (A)$	-	-	-	-	-	-	INH	97		1
TPA	Transfer CCR to A	$A \leftarrow (CCR)$	-	-	-	-	-	-	INH	85		1
TST opr TSTA TSTX TST opr,X TST ,X TST opr,SP	Test for Negative or Zero	$(A) - \$00$ or $(X) - \$00$ or $(M) - \$00$	0	-	-	⊕	⊕	-	DIR INH INH IX1 IX SP1	3D 4D 5D 6D 7D 9E6D	dd ff ff	3 1 1 3 2 4
TSX	Transfer SP to H:X	$H:X \leftarrow (SP) + 1$	-	-	-	-	-	-	INH	95		2
TXA	Transfer X to A	$A \leftarrow (X)$	-	-	-	-	-	-	INH	9F		1
TXS	Transfer H:X to SP	$(SP) \leftarrow (H:X) - 1$	-	-	-	-	-	-	INH	94		2

Table 6-1. Instruction Set Summary (Sheet 9 of 9)

Source Form	Operation	Description	Effect on CCR						Address Mode	Opcode	Operand	Cycles
			V	H	I	N	Z	C				
A	Accumulator	<i>n</i>										
C	Carry/borrow bit	<i>opr</i>										
CCR	Condition code register	PC										
dd	Direct address of operand	PCH										
dd rr	Direct address of operand and relative offset of branch instruction	PCL										
DD	Direct to direct addressing mode	REL										
DIR	Direct addressing mode	<i>rel</i>										
DIX+	Direct to indexed with post increment addressing mode	<i>rr</i>										
ee ff	High and low bytes of offset in indexed, 16-bit offset addressing	SP1										
EXT	Extended addressing mode	SP2										
ff	Offset byte in indexed, 8-bit offset addressing	SP										
H	Half-carry bit	U										
H	Index register high byte	V										
hh ll	High and low bytes of operand address in extended addressing	X										
I	Interrupt mask	Z										
ii	Immediate operand byte	&										
IMD	Immediate source to direct destination addressing mode											
IMM	Immediate addressing mode	⊕										
INH	Inherent addressing mode	()										
IX	Indexed, no offset addressing mode	(-)										
IX+	Indexed, no offset, post increment addressing mode	#										
IX+D	Indexed with post increment to direct addressing mode	«										
IX1	Indexed, 8-bit offset addressing mode	←										
IX1+	Indexed, 8-bit offset, post increment addressing mode	?										
IX2	Indexed, 16-bit offset addressing mode	:										
M	Memory location	‡										
N	Negative bit	—										

6.9 Opcode Map

See [Table 6-2](#).

Table 6-2. Opcode Map

MSB LSB	Bit Manipulation		Branch		Read-Modify-Write				Control				Register/Mem			
	DIR	DIR	REL	REL	INH	INH	IX1	SP1	IX	INH	INH	IMM	DIR	EXT	IX2	
0	0	1	2	2	4	5	6	9E6	7	8	9	A	B	C	D	
5 3	BSET0 DIR	4 2	BRA REL	3 2	1 INH	1 NEGX INH	4 NEG IX1	5 NEG SP1	3 NEG IX	7 RTI INH	3 BGE REL	2 SUB IMM	3 SUB DIR	4 SUB EXT	4 SUB IX2	9E 4
5 3	BFCLR0 DIR	4 2	BRN REL	3 2	4 CBEQA IMM	4 CBEQA IMM	5 CBEQ IX1+	6 CBEQ SP1	4 CBEQ IX	4 RTS INH	3 BLT REL	2 CMP IMM	3 CMP DIR	4 CMP EXT	4 CMP IX2	C 4
5 3	BSET1 DIR	4 2	BHI REL	3 2	5 MUL INH	7 DIV INH	3 NSA INH	4 NSA SP1	2 DAA IX	2 PUSH INH	3 BGT REL	2 SBC IMM	3 SBC DIR	4 SBC EXT	4 SBC IX2	S 4
5 3	BFCLR1 DIR	4 2	BLS REL	3 2	1 COMA INH	1 COMX INH	4 COM IX1	5 COM SP1	3 COM IX	9 SWI INH	3 BLE REL	2 CPX IMM	3 CPX DIR	4 CPX EXT	4 CPX IX2	C 4
5 3	BSET2 DIR	4 2	BCC REL	3 2	4 LSRA INH	1 LSRX INH	4 LSR IX1	5 LSR SP1	3 LSR IX	2 TAP INH	2 TXS REL	2 AND IMM	3 AND DIR	4 AND EXT	4 AND IX2	A 4
5 3	BCLR2 DIR	4 2	BCS REL	3 2	4 LDHX IMM	4 LDHX IMM	3 CPHX IMM	4 CPHX SP1	2 CPHX DIR	1 TPA INH	1 TSX REL	2 BIT IMM	3 BIT DIR	4 BIT EXT	4 BIT IX2	B 4
5 3	BSET3 DIR	4 2	BNE REL	3 2	1 RORA INH	1 RORX INH	4 ROR IX1	5 ROR SP1	3 ROR IX	2 PULA INH	2 LDA REL	2 LDA IMM	3 LDA DIR	4 LDA EXT	4 LDA IX2	L 4
5 3	BFCLR3 DIR	4 2	BEQ REL	3 2	1 ASRA INH	1 ASRX INH	4 ASR IX1	5 ASR SP1	3 ASR IX	2 PSHA INH	1 TAX REL	2 AIS IMM	3 STA DIR	4 STA EXT	4 STA IX2	S 4
5 3	BSET4 DIR	4 2	BHCC REL	3 2	1 LSLA INH	1 LSLX INH	4 LSL IX1	5 LSL SP1	3 LSL IX	2 PULX INH	1 CLC REL	2 EOR IMM	3 EOR DIR	4 EOR EXT	4 EOR IX2	E 4
5 3	BFCLR4 DIR	4 2	BHCS REL	3 2	1 ROLA INH	1 ROXL INH	4 ROL IX1	5 ROL SP1	3 ROL IX	2 PSHX INH	1 SEC REL	2 ADC IMM	3 ADC DIR	4 ADC EXT	4 ADC IX2	A 4
5 3	BSET5 DIR	4 2	BPL REL	3 2	1 DECA INH	1 DECX INH	4 DEC IX1	5 DEC SP1	3 DEC IX	2 PULH INH	2 CLI REL	2 ORA IMM	3 ORA DIR	4 ORA EXT	4 ORA IX2	O 4
5 3	BFCLR5 DIR	4 2	BMI REL	3 2	3 DBNZ INH	3 DBNZ INH	5 DBNZ IX1	6 DBNZ SP1	4 DBNZ IX	2 PSHX INH	2 SEI REL	2 ADD IMM	3 ADD DIR	4 ADD EXT	4 ADD IX2	A 4
5 3	BSET6 DIR	4 2	BMC REL	3 2	1 INCA INH	1 INCX INH	4 INC IX1	5 INC SP1	3 INC IX	1 CLR INH	1 RSP REL	2 JMP IMM	3 JMP DIR	4 JMP EXT	4 JMP IX2	J 4
5 3	BFCLR6 DIR	4 2	BMS REL	3 2	1 TSTA INH	1 TSTX INH	3 TST IX1	4 TST SP1	2 TST IX	2 NOP INH	1 NOP REL	4 BSR IMM	3 JSR DIR	5 JSR EXT	6 JSR IX2	B 4
5 3	BSET7 DIR	4 2	BIL REL	3 2	5 MOV DD	4 MOV DIX+	4 MOV IMD	4 MOV SP1	4 MOV IX+D	1 STOP INH	*	2 LDX IMM	3 LDX DIR	4 LDX EXT	4 LDX IX2	L 4
5 3	BFCLR7 DIR	4 2	BIH REL	3 2	1 CLRA INH	1 CLR INH	3 CLR IX1	4 CLR SP1	2 CLR IX	1 WAIT INH	1 TXA REL	2 AIX IMM	3 STX DIR	4 STX EXT	4 STX IX2	S 4

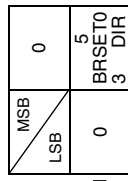

High Byte of Opcode in Hexadecimal

Low Byte of Opcode in Hexadecimal

SP1 Stack Pointer, 8-Bit Offset
 SP2 Stack Pointer, 16-Bit Offset
 IX+ Indexed, No Offset with Post Increment
 IX1+ Indexed, 1-Byte Offset with Post Increment

REL Relative
 IX Indexed, No Offset
 IX2 Indexed, 8-Bit Offset
 IX+ Indexed, 16-Bit Offset
 IMD Immediate-Direct
 DIX+ Direct-Indexed
 * Pre-byte for stack pointer indexed instructions

INH Inherent
 IMM Immediate
 DIR Direct
 EXT Extended
 DD Direct-Direct
 IX+D Indexed-Direct
 * Pre-byte for stack pointer indexed instructions



Section 7. Oscillator (OSC)

7.1 Contents

7.2	Introduction	89
7.3	Oscillator External Connections	90
7.4	I/O Signals	91
7.4.1	Crystal Amplifier Input Pin (OSC1)	91
7.4.2	Crystal Amplifier Output Pin (OSC2)	91
7.4.3	Oscillator Enable Signal (SIMOSCEN)	91
7.4.4	External Clock Source (OSCXCLK)	91
7.4.5	Oscillator Out (OSCOUT)	92
7.5	Low-Power Modes	92
7.5.1	Wait Mode	92
7.5.2	Stop Mode	92
7.6	Oscillator During Break Mode	92

7.2 Introduction

The oscillator circuit is designed for use with crystals or ceramic resonators. The oscillator circuit generates the crystal clock signal. The crystal oscillator output signal passes through the clock doubler. OSCXCLK is the output signal of the clock doubler. OSCXCLK is divided by two before being passed on to the system integration module (SIM) for bus clock generation.

Figure 7-1 shows the structure of the oscillator. The oscillator requires various external components.

7.3 Oscillator External Connections

In its typical configuration, the oscillator requires five external components. The crystal oscillator is normally connected in a Pierce oscillator configuration, as shown in **Figure 7-1**. This figure shows only the logical representation of the internal components and may not represent actual circuitry. The oscillator configuration uses five components:

- Crystal, X_1
- Fixed capacitor, C_1
- Tuning capacitor, C_2 (can also be a fixed capacitor)
- Feedback resistor, R_B
- Series resistor, R_S (optional)

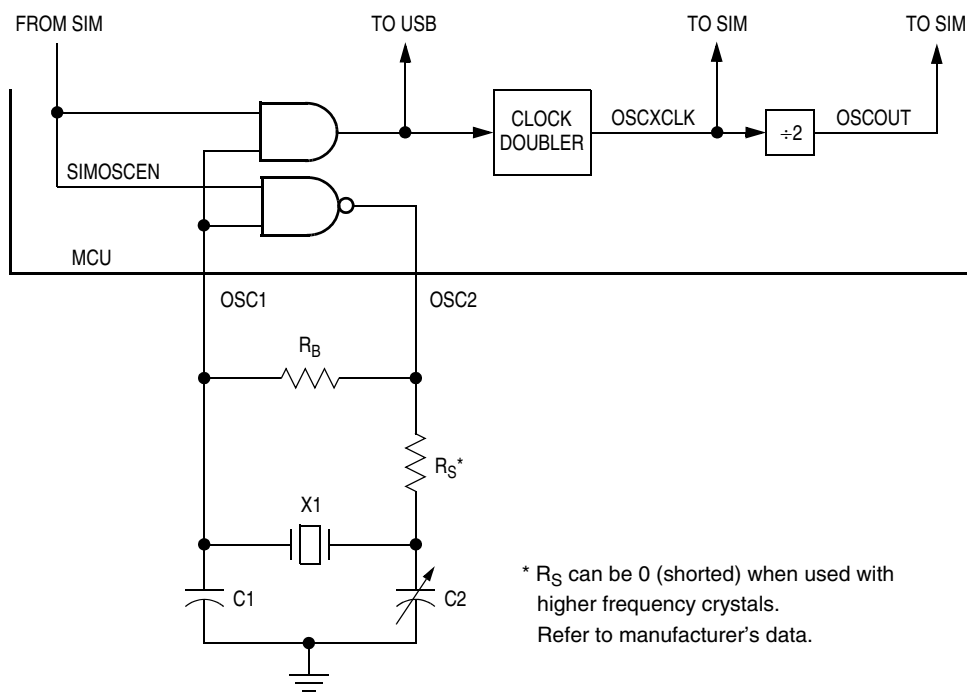

Figure 7-1. Oscillator External Connections

The series resistor (R_S) is included in the diagram to follow strict Pierce oscillator guidelines and may not be required for all ranges of operation, especially with high-frequency crystals. Refer to the crystal manufacturer's data for more information.

7.4 I/O Signals

The following paragraphs describe the oscillator input/output (I/O) signals.

7.4.1 Crystal Amplifier Input Pin (OSC1)

The OSC1 pin is an input to the crystal oscillator amplifier.

7.4.2 Crystal Amplifier Output Pin (OSC2)

The OSC2 pin is the output of the crystal oscillator inverting amplifier.

7.4.3 Oscillator Enable Signal (SIMOSCEN)

The SIMOSCEN signal comes from the system integration module (SIM) and enables the oscillator.

7.4.4 External Clock Source (OSCXCLK)

The crystal oscillator output signal passes through the clock doubler and OSCXCLK is the output signal of the clock doubler. OSCXCLK runs at twice the speed of the crystal (f_{XCLK}). **Figure 7-1** shows only the logical relation of OSCXCLK to OSC1 and OSC2 and may not represent the actual circuitry. The duty cycle of OSCXCLK is unknown and may depend on the crystal and other external factors. Also, the frequency and amplitude of OSCXCLK can be unstable at startup.

7.4.5 Oscillator Out (OSCOUT)

The clock driven to the SIM is OSCXCLK. This signal is driven to the SIM for generation of the bus clocks used by the CPU and other modules on the MCU. OSCOUT will be divided again in the SIM and results in the internal bus frequency being one fourth of the OSCXCLK frequency or one half of the crystal frequency.

7.5 Low-Power Modes

The WAIT and STOP instructions put the MCU in low-power-consumption standby modes.

7.5.1 Wait Mode

The WAIT instruction has no effect on the oscillator logic. OSCXCLK continues to drive to the SIM module.

7.5.2 Stop Mode

The STOP instruction disables the OSCXCLK output.

7.6 Oscillator During Break Mode

The oscillator continues to drive OSCXCLK when the chip enters the break state.

Section 8. System Integration Module (SIM)

8.1 Contents

8.2	Introduction	94
8.3	SIM Bus Clock Control and Generation	96
8.3.1	Bus Timing	97
8.3.2	Clock Startup from POR or LVI Reset	97
8.3.3	Clocks in Stop Mode and Wait Mode	97
8.4	Reset and System Initialization.	97
8.4.1	External Pin Reset	98
8.4.2	Active Resets from Internal Sources	99
8.4.2.1	Power-On Reset	100
8.4.2.2	Computer Operating Properly (COP) Reset.	101
8.4.2.3	Illegal Opcode Reset	101
8.4.2.4	Illegal Address Reset.	101
8.4.2.5	Low-Voltage Inhibit (LVI) Reset	102
8.4.2.6	Universal Serial Bus Reset	102
8.4.2.7	Registers Values After Different Resets.	102
8.5	SIM Counter	103
8.5.1	SIM Counter During Power-On Reset	103
8.5.2	SIM Counter During Stop Mode Recovery.	104
8.5.3	SIM Counter and Reset States.	104
8.6	Exception Control	104
8.6.1	Interrupts	104
8.6.1.1	Hardware Interrupts	107
8.6.1.2	SWI Instruction.	108
8.6.2	Interrupt Status Registers.	108
8.6.2.1	Interrupt Status Register 1	109
8.6.3	Reset	109
8.6.4	Break Interrupts	109
8.6.5	Status Flag Protection in Break Mode	110

8.7	Low-Power Modes	110
8.7.1	Wait Mode	110
8.7.2	Stop Mode	112
8.8	SIM Registers	113
8.8.1	Break Status Register	113
8.8.2	Reset Status Register	114
8.8.3	Break Flag Control Register	116

8.2 Introduction

This section describes the system integration module (SIM), which supports up to 8 external and/or internal interrupts. Together with the CPU, the SIM controls all MCU activities. The SIM is a system state controller that coordinates CPU and exception timing. A block diagram of the SIM is shown in [Figure 8-1](#). [Figure 8-2](#) is a summary of the SIM I/O registers. The SIM is responsible for:

- Bus clock generation and control for CPU and peripherals
 - Stop/wait/reset/break entry and recovery
 - Internal clock control
- Master reset control, including power-on reset (POR) and COP timeout
- Interrupt control:
 - Acknowledge timing
 - Arbitration control timing
 - Vector address generation
- CPU enable/disable timing
- Modular architecture expandable to 128 interrupt sources

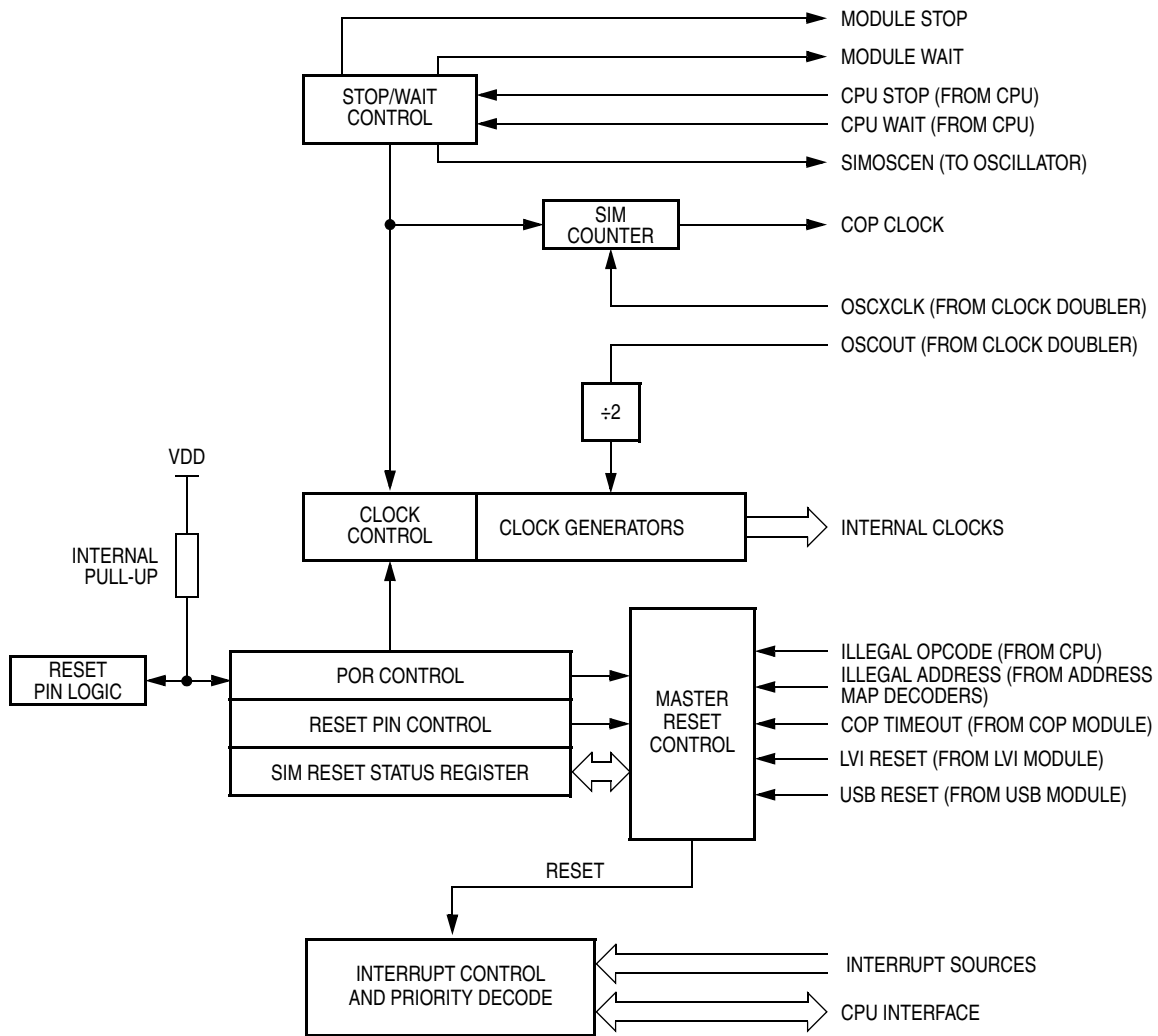

Figure 8-1. SIM Block Diagram

Table 8-1. SIM Module Signal Name Conventions

Signal Name	Description
OSCXCLK	Clock doubler output which has twice the frequency of OSC1 from the oscillator
OSCOUT	The OSCXCLK frequency divided by two. This signal is again divided by two in the SIM to generate the internal bus clocks. (Bus clock = OSCXCLK ÷ 4 = f _{OSC} ÷ 2)
IAB	Internal address bus
IDB	Internal data bus
PORRST	Signal from the power-on reset module to the SIM
IRST	Internal reset signal
R/W	Read/write signal

Addr.	Register Name		Bit 7	6	5	4	3	2	1	Bit 0
\$FE00	Break Status Register (BSR)	Read:	R	R	R	R	R	R	SBSW	R
		Write:							See note	
		Reset:	0							
Note: Writing a logic 0 clears SBSW.										
\$FE01	Reset Status Register (RSR)	Read:	POR	PIN	COP	ILOP	ILAD	USB	LVI	0
		Write:								
		POR:	1	0	0	0	0	0	0	0
\$FE02	Reserved	Read:	R	R	R	R	R	R	R	R
		Write:								
\$FE03	Break Flag Control Register (BFCR)	Read:	BCFE	R	R	R	R	R	R	R
		Write:								
		Reset:	0							
\$FE04	Interrupt Status Register 1 (INT1)	Read:	IF6	IF5	IF4	IF3	IF2	IF1	0	0
		Write:	R	R	R	R	R	R	R	R
		Reset:	0	0	0	0	0	0	0	0

Figure 8-2. SIM I/O Register Summary

8.3 SIM Bus Clock Control and Generation

The bus clock generator provides system clock signals for the CPU and peripherals on the MCU. The system clocks are generated from an incoming clock, OSCOUT, as shown in [Figure 8-3](#).

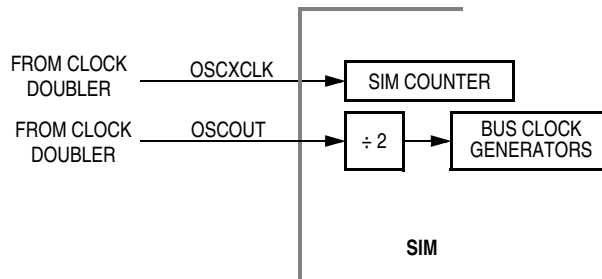

Figure 8-3. SIM Clock Signals

8.3.1 Bus Timing

In user mode, the internal bus frequency is the oscillator frequency divided by two.

8.3.2 Clock Startup from POR or LVI Reset

When the power-on reset (POR) module or the low-voltage inhibit module generates a reset, the clocks to the CPU and peripherals are inactive and held in an inactive phase until after the 4096 OSCXCLK cycle POR timeout has completed. The $\overline{\text{RST}}$ pin is driven low by the SIM during this entire period. The IBUS clocks start upon completion of the timeout.

8.3.3 Clocks in Stop Mode and Wait Mode

Upon exit from stop mode by an interrupt, break, or reset, the SIM allows OSCXCLK to clock the SIM counter. The CPU and peripheral clocks do not become active until after the stop delay timeout. This timeout is selectable as 4096 or 2048 OSCXCLK cycles. (See [8.7.2 Stop Mode](#).)

In wait mode, the CPU clocks are inactive. The SIM also produces two sets of clocks for other modules. Refer to the wait mode subsection of each module to see if the module is active or inactive in wait mode. Some modules can be programmed to be active in wait mode.

8.4 Reset and System Initialization

The MCU has these reset sources:

- Power-on reset module (POR)
- External reset pin ($\overline{\text{RST}}$)
- Computer operating properly module (COP)
- Illegal opcode
- Illegal address
- Universal serial bus module (USB)
- Low-voltage inhibit module (LVI)

All of these resets produce the vector \$FFFE–FFFF (\$FEFE–FEFF in monitor mode) and assert the internal reset signal (IRST). IRST causes all registers to be returned to their default values and all modules to be returned to their reset states.

An internal reset clears the SIM counter (see [8.5 SIM Counter](#)), but an external reset does not. Each of the resets sets a corresponding bit in the reset status register (RSR). (See [8.8 SIM Registers](#).)

8.4.1 External Pin Reset

The $\overline{\text{RST}}$ pin circuit includes an internal pullup device. Pulling the asynchronous $\overline{\text{RST}}$ pin low halts all processing. The PIN bit of the reset status register (RSR) is set as long as $\overline{\text{RST}}$ is held low for a minimum of 67 OSCXCLK cycles, assuming that neither the POR nor the LVI was the source of the reset. See [Table 8-2](#) for details. [Figure 8-4](#) shows the relative timing.

Table 8-2. PIN Bit Set Timing

Reset Type	Number of Cycles Required to Set PIN
POR/LVI	4163 (4096 + 64 + 3)
All others	67 (64 + 3)

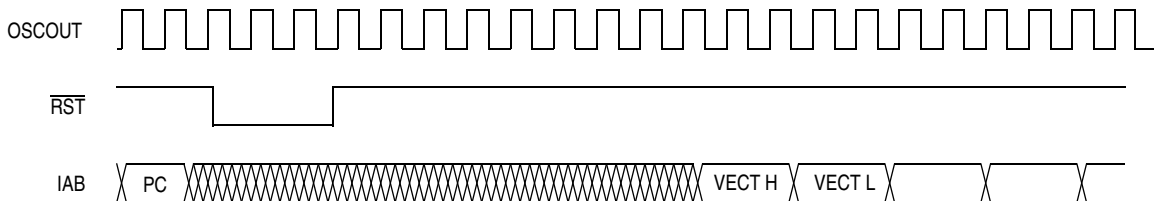

Figure 8-4. External Reset Timing

8.4.2 Active Resets from Internal Sources

All internal reset sources actively pull the \overline{RST} pin low for 32 OSCXCLK cycles to allow resetting of external peripherals. The internal reset signal IRST continues to be asserted for an additional 32 cycles. (See Figure 8-5.) An internal reset can be caused by an illegal address, illegal opcode, COP timeout, LVI, the USB module or POR. (See [Figure 8-6 . Sources of Internal Reset.](#))

NOTE: For LVI or POR resets, the SIM cycles through 4096 OSCXCLK cycles during which the SIM forces the \overline{RST} pin low. The internal reset signal then follows the sequence from the falling edge of \overline{RST} shown in [Figure 8-5.](#)

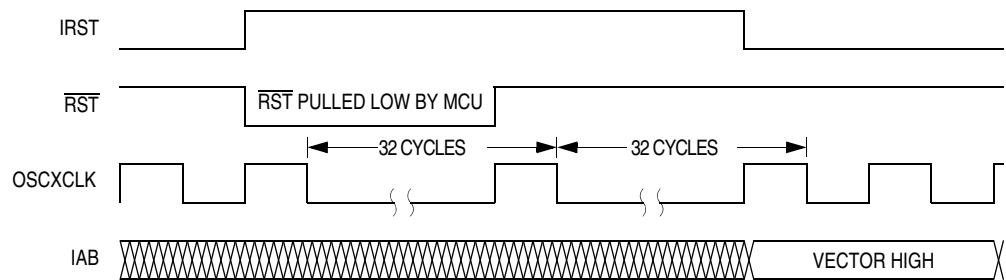

Figure 8-5. Internal Reset Timing

The COP reset is asynchronous to the bus clock.

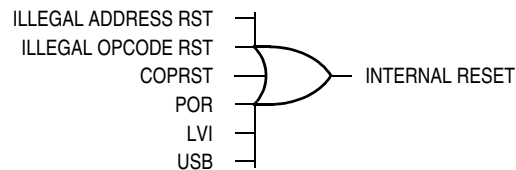

Figure 8-6. Sources of Internal Reset

The active reset feature allows the part to issue a reset to peripherals and other chips within a system built around the MCU.

8.4.2.1 Power-On Reset

When power is first applied to the MCU, the power-on reset module (POR) generates a pulse to indicate that power-on has occurred. The external reset pin ($\overline{\text{RST}}$) is held low while the SIM counter counts out 4096 OSCXCLK cycles. Sixty-four OSCXCLK cycles later, the CPU and memories are released from reset to allow the reset vector sequence to occur.

At power-on, the following events occur:

- A POR pulse is generated.
- The internal reset signal is asserted.
- The SIM enables the oscillator to drive OSCXCLK.
- Internal clocks to the CPU and modules are held inactive for 4096 OSCXCLK cycles to allow stabilization of the oscillator.
- The $\overline{\text{RST}}$ pin is driven low during the oscillator stabilization time.
- The POR bit of the reset status register (RSR) is set and all other bits in the register are cleared.

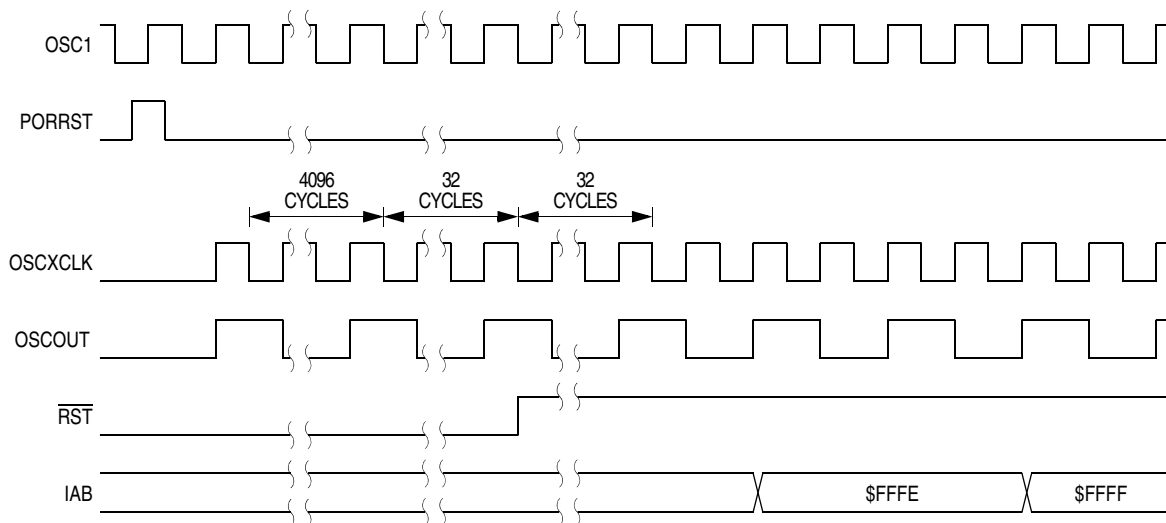

Figure 8-7. POR Recovery

8.4.2.2 Computer Operating Properly (COP) Reset

An input to the SIM is reserved for the COP reset signal. The overflow of the COP counter causes an internal reset and sets the COP bit in the reset status register (RSR). The SIM actively pulls down the $\overline{\text{RST}}$ pin for all internal reset sources.

To prevent a COP module timeout, write any value to location \$FFFF. Writing to location \$FFFF clears the COP counter and stages 12 through 5 of the SIM counter. The SIM counter output, which occurs at least every $2^{12} - 2^4$ OSCXCLK cycles, drives the COP counter. The COP should be serviced as soon as possible out of reset to guarantee the maximum amount of time before the first timeout.

The COP module is disabled if the $\overline{\text{RST}}$ pin or the $\overline{\text{IRQ}}$ pin is held at $V_{\text{DD}} + V_{\text{HI}}$ while the MCU is in monitor mode. The COP module can be disabled only through combinational logic conditioned with the high voltage signal on the $\overline{\text{RST}}$ or the $\overline{\text{IRQ}}$ pin. This prevents the COP from becoming disabled as a result of external noise. During a break state, $V_{\text{DD}} + V_{\text{HI}}$ on the $\overline{\text{RST}}$ pin disables the COP module.

8.4.2.3 Illegal Opcode Reset

The SIM decodes signals from the CPU to detect illegal instructions. An illegal instruction sets the ILOP bit in the reset status register (RSR) and causes a reset.

If the stop enable bit, STOP, in the mask option register is logic 0, the SIM treats the STOP instruction as an illegal opcode and causes an illegal opcode reset. The SIM actively pulls down the $\overline{\text{RST}}$ pin for all internal reset sources.

8.4.2.4 Illegal Address Reset

An opcode fetch from an unmapped address generates an illegal address reset. The SIM verifies that the CPU is fetching an opcode prior to asserting the ILAD bit in the reset status register (RSR) and resetting the MCU. A data fetch from an unmapped address does not generate a reset. The SIM actively pulls down the $\overline{\text{RST}}$ pin for all internal reset sources.

8.4.2.5 Low-Voltage Inhibit (LVI) Reset

The low-voltage inhibit module (LVI) asserts its output to the SIM when the V_{DD} voltage falls to the LVI reset voltage, V_{TRIP} . The LVI bit in the reset status register (RSR) is set, and the external reset pin (\overline{RST}) is held low while the SIM counter counts out 4096 OSCXCLK cycles. Sixty-four OSCXCLK cycles later, the CPU is released from reset to allow the reset vector sequence to occur. The SIM actively pulls down the \overline{RST} pin for all internal reset sources.

8.4.2.6 Universal Serial Bus Reset

The USB module will detect a reset signaled on the bus by the presence of an extended SE0 at the USB data pins of a device. The MCU seeing a single-ended 0 on its USB data inputs for more than $2.5\mu s$ treats that signal as a reset. After the reset is removed, the device will be in the attached, but not yet addressed or configured, state (refer to Section 9.1 USB Devices of the *Universal Serial Bus Specification* Rev. 1.1). The device must be able to accept the device address via a SET_ADDRESS command (refer to Section 9.4 of the *Universal Serial Bus Specification* Rev. 1.1) no later than 10ms after the reset is removed.

USB reset can be disabled to generate an internal reset, instead, a USB interrupt can be generated. (See [Section 5. Configuration Register \(CONFIG\)](#).)

NOTE: *USB reset is disabled when the USB module is disabled by clearing the USBEN bit of the USB Address Register (UADDR).*

8.4.2.7 Registers Values After Different Resets

Some registers are reset by POR or LVI reset only. [Table 8-3](#) shows the registers or register bits which are unaffected by normal resets.

Table 8-3. Registers not Affected by Normal Reset

Bits	Registers	After Reset (except POR or LVI)	After POR or LVI
URSTD, LVIDIS	CONFIG	Unaffected	0
USBEN	UADDR	Unaffected	0
PULLEN	UCR3	Unaffected	0
All	USR0, USR1	Unaffected	Indeterminate
All	UE0D0–UE0D7	Unaffected	Indeterminate
All	UE1D0–UE1D7	Unaffected	Indeterminate
All	UE2D0–UE2D7	Unaffected	Indeterminate
All	PTA, PTB, PTC, PTD, and PTE	Unaffected	Indeterminate
DDRA7	DDRA	Unaffected	0

8.5 SIM Counter

The SIM counter is used by the power-on reset module (POR) and in stop mode recovery to allow the oscillator time to stabilize before enabling the internal bus (IBUS) clocks. The SIM counter also serves as a prescaler for the computer operating properly module (COP). The SIM counter uses 12 stages for counting, followed by a 13th stage that triggers a reset of SIM counters and supplies the clock for the COP module. The SIM counter is clocked by the falling edge of OSCXCLK.

8.5.1 SIM Counter During Power-On Reset

The power-on reset module (POR) detects power applied to the MCU. At power-on, the POR circuit asserts the signal PORRST. Once the SIM is initialized, it enables the oscillator to drive the bus clock state machine.

8.5.2 SIM Counter During Stop Mode Recovery

The SIM counter also is used for stop mode recovery. The STOP instruction clears the SIM counter. After an interrupt, break, or reset, the SIM senses the state of the short stop recovery bit, SSREC, in the configuration register (CONFIG). If the SSREC bit is a logic 1, then the stop recovery is reduced from the normal delay of 4096 OSCXCLK cycles down to 2048 OSCXCLK cycles. This is ideal for applications using canned oscillators that do not require long startup times from stop mode. External crystal applications should use the full stop recovery time, that is, with SSREC cleared in the configuration register (CONFIG).

8.5.3 SIM Counter and Reset States

External reset has no effect on the SIM counter. (See [8.7.2 Stop Mode](#) for details.) The SIM counter is free-running after all reset states. (See [8.4.2 Active Resets from Internal Sources](#) for counter control and internal reset recovery sequences.)

8.6 Exception Control

Normal, sequential program execution can be changed in three different ways:

- Interrupts
 - Maskable hardware CPU interrupts
 - Non-maskable software interrupt instruction (SWI)
- Reset
- Break interrupts

8.6.1 Interrupts

An interrupt temporarily changes the sequence of program execution to respond to a particular event. [Figure 8-8](#) flow charts the handling of system interrupts.

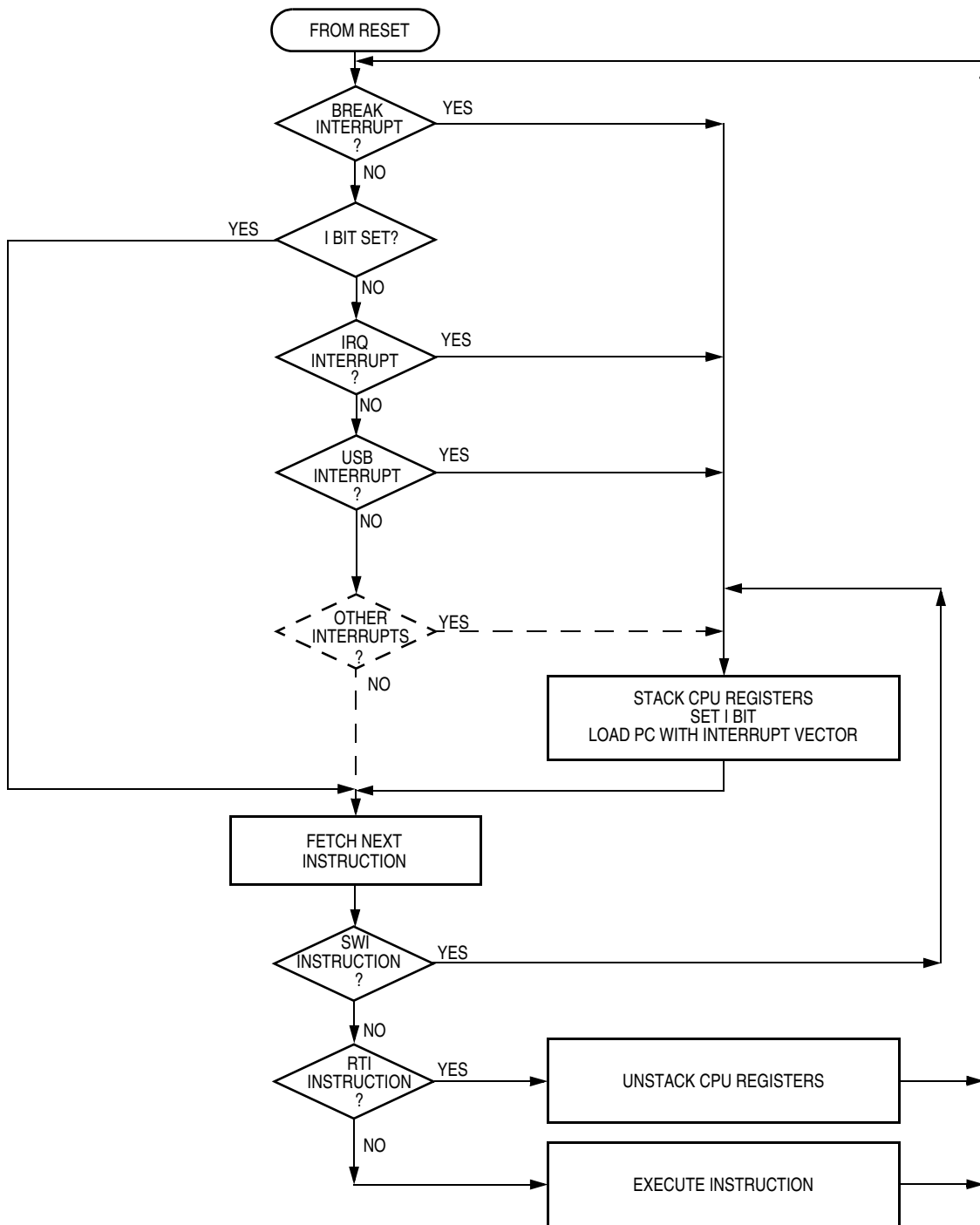

Figure 8-8. Interrupt Processing

Interrupts are latched and arbitration is performed in the SIM at the start of interrupt processing. The arbitration result is a constant that the CPU uses to determine which vector to fetch. Once an interrupt is latched by the SIM, no other interrupt can take precedence, regardless of priority, until the latched interrupt is serviced or the I bit is cleared.

At the beginning of an interrupt, the CPU saves the CPU register contents on the stack and sets the interrupt mask (I bit) to prevent additional interrupts. At the end of an interrupt, the RTI instruction recovers the CPU register contents from the stack so that normal processing can resume. **Figure 8-9** shows interrupt entry timing. **Figure 8-10** shows interrupt recovery timing.

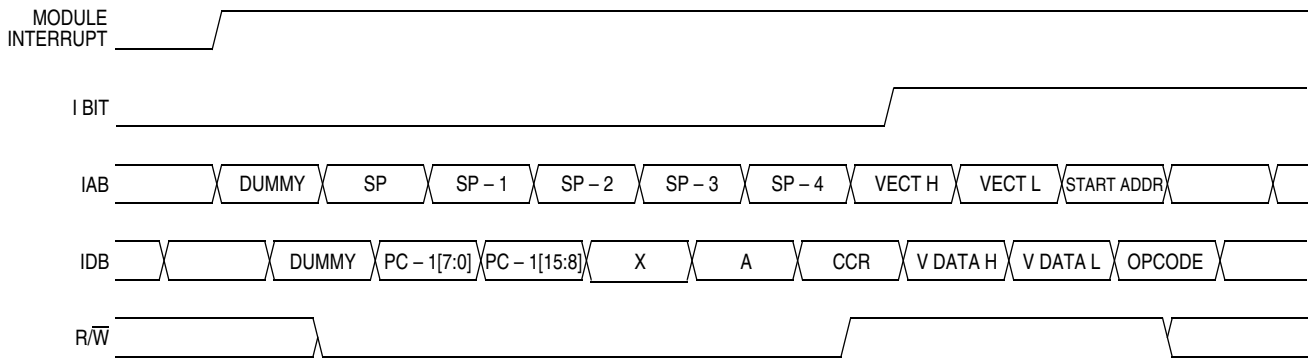

Figure 8-9. Interrupt Entry

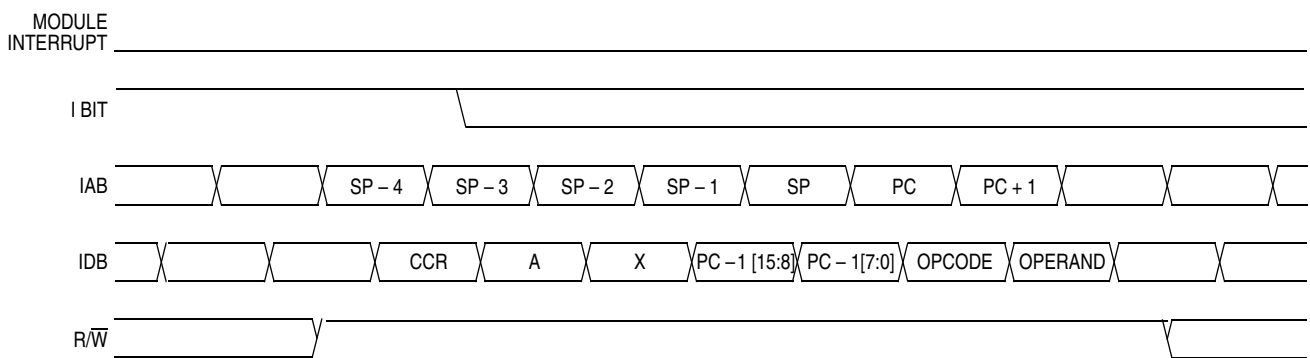

Figure 8-10. Interrupt Recovery

8.6.1.1 Hardware Interrupts

A hardware interrupt does not stop the current instruction. Processing of a hardware interrupt begins after completion of the current instruction. When the current instruction is complete, the SIM checks all pending hardware interrupts. If interrupts are not masked (I bit clear in the condition code register) and if the corresponding interrupt enable bit is set, the SIM proceeds with interrupt processing; otherwise, the next instruction is fetched and executed.

If more than one interrupt is pending at the end of an instruction execution, the highest priority interrupt is serviced first. **Figure 8-11** demonstrates what happens when two interrupts are pending. If an interrupt is pending upon exit from the original interrupt service routine, the pending interrupt is serviced before the LDA instruction is executed.

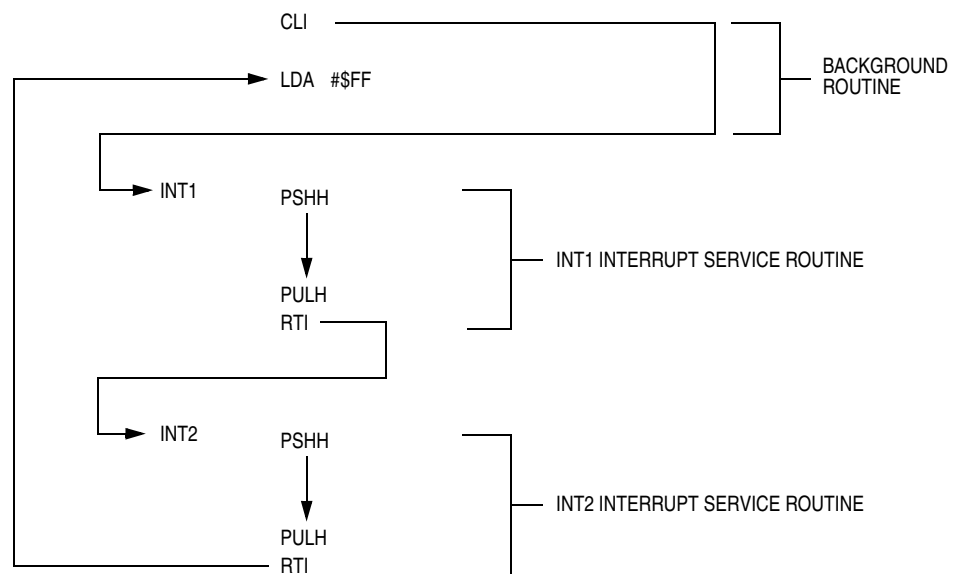

Figure 8-11. Interrupt Recognition Example

The LDA opcode is prefetched by both the INT1 and INT2 RTI instructions. However, in the case of the INT1 RTI prefetch, this is a redundant operation.

NOTE: *To maintain compatibility with the M6805 Family, the H register is not pushed on the stack during interrupt entry. If the interrupt service routine modifies the H register or uses the indexed addressing mode, software should save the H register and then restore it prior to exiting the routine.*

8.6.1.2 SWI Instruction

The SWI instruction is a non-maskable instruction that causes an interrupt regardless of the state of the interrupt mask (I bit) in the condition code register.

NOTE: *A software interrupt pushes PC onto the stack. A software interrupt does not push PC-1, as a hardware interrupt does.*

8.6.2 Interrupt Status Registers

The flags in the interrupt status registers identify maskable interrupt sources. [Table 8-4](#) summarizes the interrupt sources and the interrupt status register flags that they set. The interrupt status registers can be useful for debugging.

Table 8-4. Interrupt Sources

Source	Flags	Mask ⁽¹⁾	INT Register Flag	Priority ⁽²⁾	Vector Address
SWI Instruction			—	0	\$FFFC-\$FFFD
USB Reset Interrupt	RSTF	URSTD	IF2	1	\$FFFA-\$FFFB
USB Endpoint 0 Transmit	TXD0F	TXD0IE			
USB Endpoint 0 Receive	RXD0F	RXD0IE			
USB Endpoint 1 Transmit	TXD1F	TXD1IE			
USB Endpoint 2 Transmit	TXD2F	TXD2IE			
USB Endpoint 2 Receive	RXD2F	RXD2IE			
USB End of Packet	EOPF	EOPIE			
USB Resume Interrupt	RESUMF	—			
IRQ Interrupt (\overline{IRQ} , PTE4)	IRQF PTE4IF	IMASK			
TIM Channel 0	CH0F	CH0IE	IF3	3	\$FFF6-\$FFF7
TIM Channel 1	CH1F	CH1IE	IF4	4	\$FFF4-\$FFF5
TIM Overflow	TOF	TOIE	IF5	5	\$FFF2-\$FFF3
Keyboard Interrupt	KEYF	IMASKK	IF6	6	\$FFF0-\$FFF1

1. The I bit in the condition code register is a global mask for all interrupt sources except the SWI instruction.

2. 0 = highest priority

8.6.2.1 Interrupt Status Register 1

Address: \$FE04

	Bit 7	6	5	4	3	2	1	Bit 0
Read:	IF6	IF5	IF4	IF3	IF2	IF1	0	0
Write:	R	R	R	R	R	R	R	R
Reset:	0	0	0	0	0	0	0	0

R = Reserved

Figure 8-12. Interrupt Status Register 1 (INT1)

IF6–IF1 — Interrupt Flags 1–6

These flags indicate the presence of interrupt requests from the sources shown in [Table 8-4](#).

1 = Interrupt request present

0 = No interrupt request present

Bit 0 and Bit 1 — Always read 0

8.6.3 Reset

All reset sources always have equal and highest priority and cannot be arbitrated.

8.6.4 Break Interrupts

The break module can stop normal program flow at a software-programmable break point by asserting its break interrupt output. (See [Section 17. Break Module \(BREAK\)](#).) The SIM puts the CPU into the break state by forcing it to the SWI vector location. Refer to the break interrupt subsection of each module to see how each module is affected by the break state.

8.6.5 Status Flag Protection in Break Mode

The SIM controls whether status flags contained in other modules can be cleared during break mode. The user can select whether flags are protected from being cleared by properly initializing the break clear flag enable bit (BCFE) in the break flag control register (BFCR).

Protecting flags in break mode ensures that set flags will not be cleared while in break mode. This protection allows registers to be freely read and written during break mode without losing status flag information.

Setting the BCFE bit enables the clearing mechanisms. Once cleared in break mode, a flag remains cleared even when break mode is exited. Status flags with a 2-step clearing mechanism — for example, a read of one register followed by the read or write of another — are protected, even when the first step is accomplished prior to entering break mode. Upon leaving break mode, execution of the second step will clear the flag as normal.

8.7 Low-Power Modes

Executing the WAIT or STOP instruction puts the MCU in a low-power-consumption mode for standby situations. The SIM holds the CPU in a non-clocked state. The operation of each of these modes is described here. Both STOP and WAIT clear the interrupt mask (I) in the condition code register, allowing interrupts to occur.

8.7.1 Wait Mode

In wait mode, the CPU clocks are inactive while the peripheral clocks continue to run. [Figure 8-13](#) shows the timing for wait mode entry.

A module that is active during wait mode can wake up the CPU with an interrupt if the interrupt is enabled. Stacking for the interrupt begins one cycle after the WAIT instruction during which the interrupt occurred. In wait mode, the CPU clocks are inactive. Refer to the wait mode subsection of each module to see if the module is active or inactive in wait mode. Some modules can be programmed to be active in wait mode.

Wait mode can also be exited by a reset or break. A break interrupt during wait mode sets the SIM break stop/wait bit, SBSW, in the break status register (BSR). If the COP disable bit, COPD, in the mask option register is logic 0, then the computer operating properly module (COP) is enabled and remains active in wait mode.

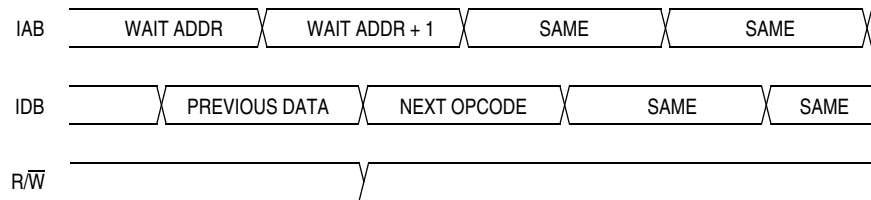

NOTE: Previous data can be operand data or the WAIT opcode, depending on the last instruction.

Figure 8-13. Wait Mode Entry Timing

Figure 8-14 and **Figure 8-15** show the timing for WAIT recovery.

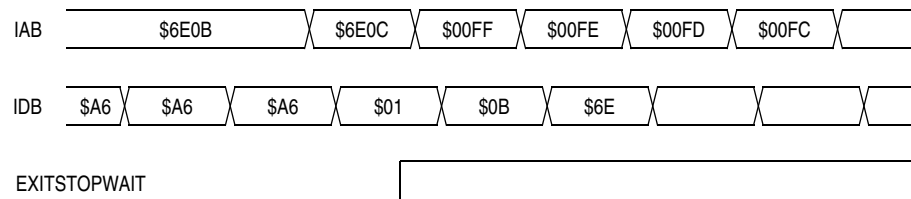

NOTE: EXITSTOPWAIT = $\overline{\text{RST}}$ pin or CPU interrupt or break interrupt

Figure 8-14. Wait Recovery from Interrupt or Break

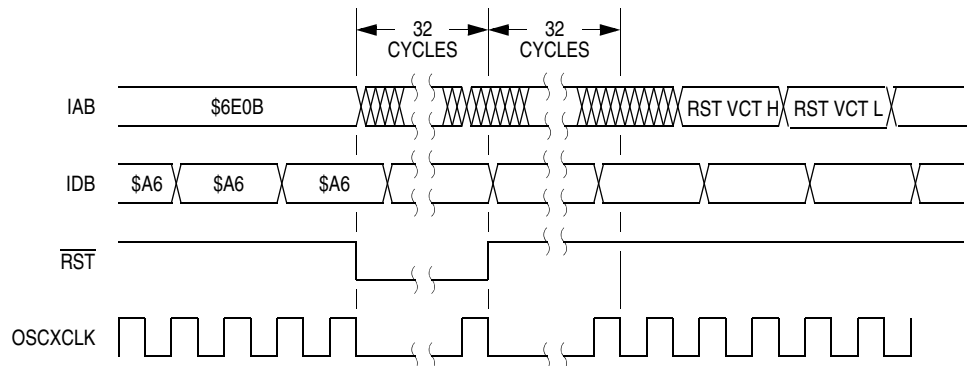

Figure 8-15. Wait Recovery from Internal Reset

8.7.2 Stop Mode

In stop mode, the SIM counter is reset and the system clocks are disabled. An interrupt request from a module can cause an exit from stop mode. Stacking for interrupts begins after the selected stop recovery time has elapsed. Reset or break also causes an exit from stop mode.

The SIM disables the oscillator signals (OSCOOUT and OSCXCLK) in stop mode, stopping the CPU and peripherals. Stop recovery time is selectable using the SSREC bit in the configuration register (CONFIG). If SSREC is set, stop recovery is reduced from the normal delay of 4096 OSCXCLK cycles down to 2048. This is ideal for applications using canned oscillators that do not require long startup times from stop mode.

NOTE: *External crystal applications should use the full stop recovery time by clearing the SSREC bit.*

A break interrupt during stop mode sets the SIM break stop/wait bit (SBSW) in the break status register (BSR).

The SIM counter is held in reset from the execution of the STOP instruction until the beginning of stop recovery. It is then used to time the recovery period. **Figure 8-16** shows stop mode entry timing.

NOTE: *To minimize stop current, all pins configured as inputs should be driven to a logic 1 or logic 0.*

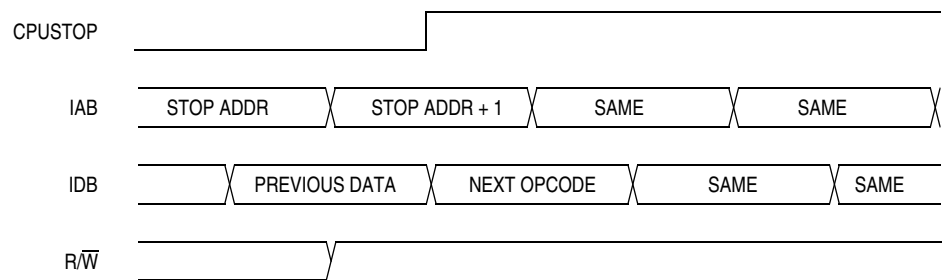

NOTE: Previous data can be operand data or the STOP opcode, depending on the last instruction.

Figure 8-16. Stop Mode Entry Timing

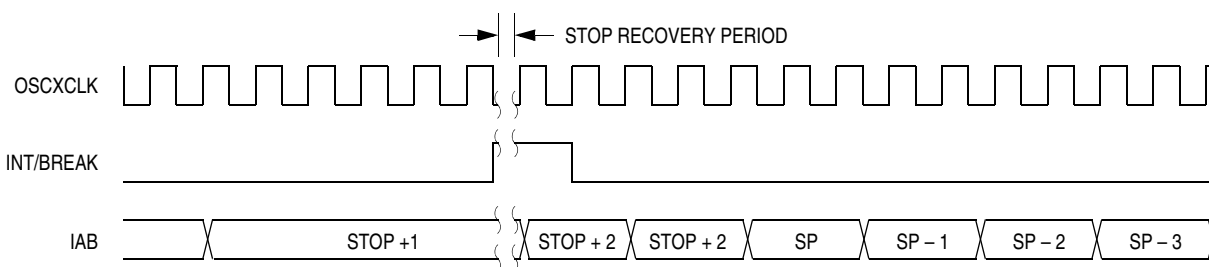

Figure 8-17. Stop Mode Recovery from Interrupt or Break

8.8 SIM Registers

The SIM has two break registers and one reset register.

8.8.1 Break Status Register

The break status register contains a flag to indicate that a break caused an exit from stop or wait mode.

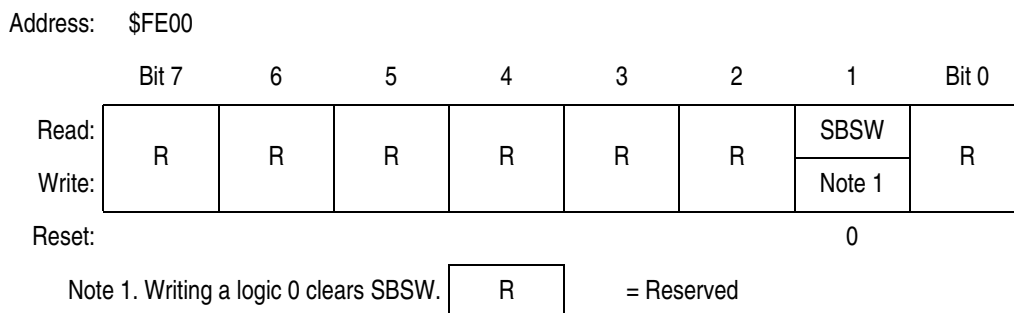

Figure 8-18. Break Status Register (BSR)

SBSW — SIM Break Stop/Wait

This status bit is useful in applications requiring a return to wait or stop mode after exiting from a break interrupt. Clear SBSW by writing a logic 0 to it. Reset clears SBSW.

1 = Stop mode or wait mode was exited by break interrupt

0 = Stop mode or wait mode was not exited by break interrupt

SBSW can be read within the break state SWI routine. The user can modify the return address on the stack by subtracting one from it. The following code is an example of this. Writing 0 to the SBSW bit clears it.

This code works if the H register has been pushed onto the stack in the break service routine software. This code should be executed at the end of the break service routine software.

```

HIBYTE EQU 5
LOBYTE EQU 6
;      If not SBSW, do RTI
      BRCLR SBSW,BSR, RETURN ; See if wait mode or stop mode was exited
                                ; by break.
      TST LOBYTE,SP ; If RETURNLO is not zero,
      BNE DOLO ; then just decrement low byte.
      DEC HIBYTE,SP ; Else deal with high byte, too.
DOLO DEC LOBYTE,SP ; Point to WAIT/STOP opcode.
RETURN PULH ; Restore H register.
      RTI

```

8.8.2 Reset Status Register

This register contains seven flags that show the source of the last reset. All flag bits are cleared automatically following a read of the register. The register is initialized on power-up as shown with the POR bit set and all other bits cleared. However, during a POR or any other internal reset, the $\overline{\text{RST}}$ pin is pulled low. After the pin is released, it will be sampled 32 XCLK cycles later. If the pin is not above a V_{IH} at that time, then the PIN bit in the RSR may be set in addition to whatever other bits are set.

Address: \$FE01

	Bit 7	6	5	4	3	2	1	Bit 0
Read:	POR	PIN	COP	ILOP	ILAD	USB	LVI	0
Write:								
POR:	1	0	0	0	0	0	0	0

 = Unimplemented

Figure 8-19. Reset Status Register (RSR)

POR — Power-On Reset Bit

1 = A POR has occurred

0 = Read of RSR

PIN — External Reset Bit

1 = An external reset has occurred since the last read of the RSR

0 = Read of RSR

COP — Computer Operating Properly Reset Bit

1 = A COP reset has occurred since the last read of the RSR

0 = POR or read of RSR

ILOP — Illegal Opcode Reset Bit

An illegal opcode reset has occurred since the last read of the RSR

0 = POR or read of RSR

ILAD — Illegal Address Reset Bit (opcode fetches only)

1 = An illegal address reset has occurred since the last read of the RSR

0 = POR or read of RSR

USB — Universal Serial Bus Reset Bit

1 = Last reset caused by the USB module

0 = POR or read of RSR

LVI — Low voltage inhibit Reset Bit

1 = A LVI reset has occurred since the last read of PSR

0 = POR or read of RSR

8.8.3 Break Flag Control Register

The break control register contains a bit that enables software to clear status bits while the MCU is in a break state.

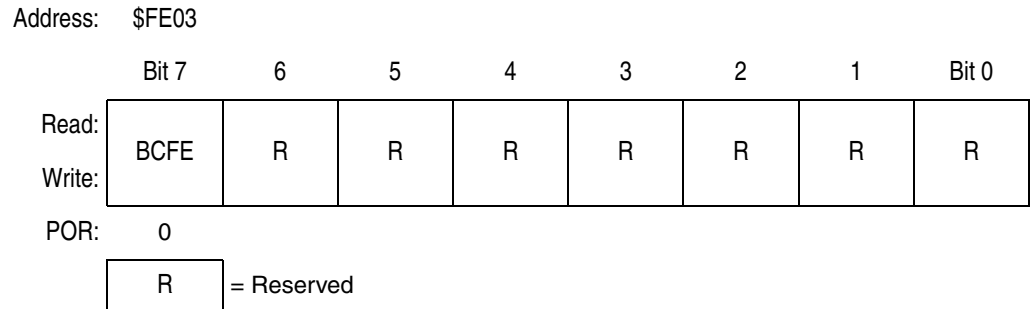

Figure 8-20. Break Flag Control Register (BFCR)

BCFE — Break Clear Flag Enable Bit

This read/write bit enables software to clear status bits by accessing status registers while the MCU is in a break state. To clear status bits during the break state, the BCFE bit must be set.

1 = Status bits clearable during break

0 = Status bits not clearable during break

Section 9. Universal Serial Bus Module (USB)

9.1 Contents

9.2	Introduction	118
9.3	Features	119
9.4	Pin Name Conventions	120
9.5	Functional Description	124
9.5.1	USB Protocol	125
9.5.1.1	Sync Pattern	126
9.5.1.2	Packet Identifier Field	127
9.5.1.3	Address Field (ADDR)	128
9.5.1.4	Endpoint Field (ENDP)	128
9.5.1.5	Cyclic Redundancy Check (CRC)	128
9.5.1.6	End-of-Packet (EOP)	128
9.5.2	Reset Signaling	129
9.5.3	Suspend	130
9.5.4	Resume After Suspend	131
9.5.4.1	Host Initiated Resume	131
9.5.4.2	USB Reset Signalling	131
9.5.4.3	Remote Wakeup	131
9.5.5	Low-Speed Device	132
9.6	Clock Requirements	132
9.7	Hardware Description	133
9.7.1	Voltage Regulator	133
9.7.2	USB Transceiver	133
9.7.2.1	Output Driver Characteristics	134
9.7.2.2	Low Speed (1.5 Mbps) Driver Characteristics	134
9.7.2.3	Receiver Data Jitter	135
9.7.2.4	Data Source Jitter	135
9.7.2.5	Data Signal Rise and Fall Time	136

9.7.3	USB Control Logic	137
9.8	I/O Registers	137
9.8.1	USB Address Register	138
9.8.2	USB Interrupt Register 0	139
9.8.3	USB Interrupt Register 1	141
9.8.4	USB Interrupt Register 2	144
9.8.5	USB Control Register 0	145
9.8.6	USB Control Register 1	146
9.8.7	USB Control Register 2	147
9.8.8	USB Control Register 3	149
9.8.9	USB Control Register 4	151
9.8.10	USB Status Register 0	152
9.8.11	USB Status Register 1	153
9.8.12	USB Endpoint 0 Data Registers	154
9.8.13	USB Endpoint 1 Data Registers	155
9.8.14	USB Endpoint 2 Data Registers	156
9.9	USB Interrupts	157
9.9.1	USB End-of-Transaction Interrupt	157
9.9.1.1	Receive Control Endpoint 0	158
9.9.1.2	Transmit Control Endpoint 0	160
9.9.1.3	Transmit Endpoint 1	161
9.9.1.4	Transmit Endpoint 2	162
9.9.1.5	Receive Endpoint 2	162
9.9.2	Resume Interrupt	162
9.9.3	End-of-Packet Interrupt	162

9.2 Introduction

This section describes the universal serial bus (USB) module. The USB module is designed to serve as a low-speed (LS) USB device per the *Universal Serial Bus Specification* Rev 1.1. Control and interrupt data transfers are supported. Endpoint 0 functions as a transmit/receive control endpoint; endpoint 1 functions as interrupt transmit endpoint; endpoint 2 functions as interrupt transmit or receive endpoint.

9.3 Features

Features of the USB module include:

- Full Universal Serial Bus Specification 1.1 low-speed functions
- 1.5 Mbps data rate
- On-chip 3.3V regulator
- Endpoint 0 with 8-byte transmit buffer and 8-byte receive buffer
- Endpoint 1 with 8-byte transmit buffer
- Endpoint 2 with 8-byte transmit buffer and 8-byte receive buffer
- USB data control logic:
 - Control endpoint 0 and interrupt endpoints 1 and 2
 - Packet decoding/generation
 - CRC generation and checking
 - NRZI (Non-Return-to Zero Inserted) encoding/decoding
 - Bit-stuffing
- USB reset options:
 - Internal MCU reset generation
 - CPU interrupt request generation
- Suspend and resume operations, with remote wakeup support
- USB-generated interrupts:
 - Transaction interrupt driven
 - Resume interrupt
 - End-of-packet interrupt
 - USB reset
- STALL, NAK, and ACK handshake generation

9.4 Pin Name Conventions

The USB share two I/O pins with two port E I/O pins. The full name of the USB I/O pin is listed in [Table 9-1](#). The generic pin name appear in the text that follows.

Table 9-1. USB Module Pin Name Conventions

USB Generic Pin Names:	D+	D-
Full USB Pin Names:	PTE3/D+	PTE4/D-

Addr.	Register Name	Bit 7	6	5	4	3	2	1	Bit 0	
\$0018	USB Interrupt Register 2 (UIR2)	Read:	0	0	0	0	0	0	0	0
		Write:	EOPFR	RSTFR	TXD2FR	RXD2FR	TXD1FR	RESUMFR	TXD0FR	RXD0FR
		Reset:	0	0	0	0	0	0	0	0
\$0019	USB Control Register 2 (UCR2)	Read:	T2SEQ	STALL2	TX2E	RX2E	TP2SIZ3	TP2SIZ2	TP2SIZ1	TP2SIZ0
		Write:								
		Reset:	0	0	0	0	0	0	0	0
\$001A	USB Control Register 3 (UCR3)	Read:	TX1ST	0	OSTALL0	ISTALL0	0	PULLEN	ENABLE2	ENABLE1
		Write:		TX1STR						
		Reset:	0	0	0	0	0	0*	0	0

* PULLEN bit is reset by POR or LVI reset only.

\$001B	USB Control Register 4 (UCR4)	Read:	0	0	0	0	0	FUSBO	FDP	FDM
		Write:								
		Reset:	0	0	0	0	0	0	0	0
\$0020	USB Endpoint 0 Data Register 0 (UE0D0)	Read:	UE0R07	UE0R06	UE0R05	UE0R04	UE0R03	UE0R02	UE0R01	UE0R00
		Write:	UE0T07	UE0T06	UE0T05	UE0T04	UE0T03	UE0T02	UE0T01	UE0T00
		Reset:	Unaffected by reset							
\$0021	USB Endpoint 0 Data Register 1 (UE0D1)	Read:	UE0R17	UE0R16	UE0R15	UE0R14	UE0R13	UE0R12	UE0R11	UE0R10
		Write:	UE0T17	UE0T16	UE0T15	UE0T14	UE0T13	UE0T12	UE0T11	UE0T10
		Reset:	Unaffected by reset							

= Unimplemented
 U = Unaffected by reset

Figure 9-1. USB I/O Register Summary (Sheet 1 of 4)

Addr.	Register Name		Bit 7	6	5	4	3	2	1	Bit 0
\$0022	USB Endpoint 0 Data Register 2 (UE0D2)	Read:	UE0R27	UE0R26	UE0R25	UE0R24	UE0R23	UE0R22	UE0R21	UE0R20
		Write:	UE0T27	UE0T26	UE0T25	UE0T24	UE0T23	UE0T22	UE0T21	UE0T20
		Reset:	Unaffected by reset							
\$0023	USB Endpoint 0 Data Register 3 (UE0D3)	Read:	UE0R37	UE0R36	UE0R35	UE0R34	UE0R33	UE0R32	UE0R31	UE0R30
		Write:	UE0T37	UE0T36	UE0T35	UE0T34	UE0T33	UE0T32	UE0T31	UE0T30
		Reset:	Unaffected by reset							
\$0024	USB Endpoint 0 Data Register 4 (UE0D4)	Read:	UE0R47	UE0R46	UE0R45	UE0R44	UE0R43	UE0R42	UE0R41	UE0R40
		Write:	UE0T47	UE0T46	UE0T45	UE0T44	UE0T43	UE0T42	UE0T41	UE0T40
		Reset:	Unaffected by reset							
\$0025	USB Endpoint 0 Data Register 5 (UE0D5)	Read:	UE0R57	UE0R56	UE0R55	UE0R54	UE0R53	UE0R52	UE0R51	UE0R50
		Write:	UE0T57	UE0T56	UE0T55	UE0T54	UE0T53	UE0T52	UE0T51	UE0T50
		Reset:	Unaffected by reset							
\$0026	USB Endpoint 0 Data Register 6 (UE0D6)	Read:	UE0R67	UE0R66	UE0R65	UE0R64	UE0R63	UE0R62	UE0R61	UE0R60
		Write:	UE0T67	UE0T66	UE0T65	UE0T64	UE0T63	UE0T62	UE0T61	UE0T60
		Reset:	Unaffected by reset							
\$0027	USB Endpoint 0 Data Register 7 (UE0D7)	Read:	UE0R77	UE0R76	UE0R75	UE0R74	UE0R73	UE0R72	UE0R71	UE0R70
		Write:	UE0T77	UE0T76	UE0T75	UE0T74	UE0T73	UE0T72	UE0T71	UE0T70
		Reset:	Unaffected by reset							
\$0028	USB Endpoint 1 Data Register 0 (UE1D0)	Read:								
		Write:	UE1T07	UE1T06	UE1T05	UE1T04	UE1T03	UE1T02	UE1T01	UE1T00
		Reset:	Unaffected by reset							
\$0029	USB Endpoint 1 Data Register 1 (UE1D1)	Read:								
		Write:	UE1T17	UE1T16	UE1T15	UE1T14	UE1T13	UE1T12	UE1T11	UE1T10
		Reset:	Unaffected by reset							
\$002A	USB Endpoint 1 Data Register 2 (UE1D2)	Read:								
		Write:	UE1T27	UE1T26	UE1T25	UE1T24	UE1T23	UE1T22	UE1T21	UE1T20
		Reset:	Unaffected by reset							
\$002B	USB Endpoint 1 Data Register 3 (UE1D3)	Read:								
		Write:	UE1T37	UE1T36	UE1T35	UE1T34	UE1T33	UE1T32	UE1T31	UE1T30
		Reset:	Unaffected by reset							

= Unimplemented
 U = Unaffected by reset

Figure 9-1. USB I/O Register Summary (Sheet 2 of 4)

Universal Serial Bus Module (USB)

Addr.	Register Name	Bit 7	6	5	4	3	2	1	Bit 0	
\$002C	USB Endpoint 1 Data Register 4 (UE1D4)	Read:								
		Write:	UE1T47	UE1T46	UE1T45	UE1T44	UE1T43	UE1T42	UE1T41	UE1T40
		Reset:	Unaffected by reset							
\$002D	USB Endpoint 1 Data Register 5 (UE1D5)	Read:								
		Write:	UE1T57	UE1T56	UE1T55	UE1T54	UE1T53	UE1T52	UE1T51	UE1T50
		Reset:	Unaffected by reset							
\$002E	USB Endpoint 1 Data Register 6 (UE1D6)	Read:								
		Write:	UE1T67	UE1T66	UE1T65	UE1T64	UE1T63	UE1T62	UE1T61	UE1T60
		Reset:	Unaffected by reset							
\$002F	USB Endpoint 1 Data Register 7 (UE1D7)	Read:								
		Write:	UE1T77	UE1T76	UE1T75	UE1T74	UE1T73	UE1T72	UE1T71	UE1T70
		Reset:	Unaffected by reset							
\$0030	USB Endpoint 2 Data Register 0 (UE2D0)	Read:	UE2R07	UE2R06	UE2R05	UE2R04	UE2R03	UE2R02	UE2R01	UE2R00
		Write:	UE2T07	UE2T06	UE2T05	UE2T04	UE2T03	UE2T02	UE2T01	UE2T00
		Reset:	Unaffected by reset							
\$0031	USB Endpoint 2 Data Register 1 (UE2D1)	Read:	UE2R17	UE2R16	UE2R15	UE2R14	UE2R13	UE2R12	UE2R11	UE2R10
		Write:	UE2T17	UE2T16	UE2T15	UE2T14	UE2T13	UE2T12	UE2T11	UE2T10
		Reset:	Unaffected by reset							
\$0032	USB Endpoint 2 Data Register 2 (UE2D2)	Read:	UE2R27	UE2R26	UE2R25	UE2R24	UE2R23	UE2R22	UE2R21	UE2R20
		Write:	UE2T27	UE2T26	UE2T25	UE2T24	UE2T23	UE2T22	UE2T21	UE2T20
		Reset:	Unaffected by reset							
\$0033	USB Endpoint 2 Data Register 3 (UE2D3)	Read:	UE2R37	UE2R36	UE2R35	UE2R34	UE2R33	UE2R32	UE2R31	UE2R30
		Write:	UE2T37	UE2T36	UE2T35	UE2T34	UE2T33	UE2T32	UE2T31	UE2T30
		Reset:	Unaffected by reset							
\$0034	USB Endpoint 2 Data Register 4 (UE2D4)	Read:	UE2R47	UE2R46	UE2R45	UE2R44	UE2R43	UE2R42	UE2R41	UE2R40
		Write:	UE2T47	UE2T46	UE2T45	UE2T44	UE2T43	UE2T42	UE2T41	UE2T40
		Reset:	Unaffected by reset							
\$0035	USB Endpoint 2 Data Register 5 (UE2D5)	Read:	UE2R57	UE2R56	UE2R55	UE2R54	UE2R53	UE2R52	UE2R51	UE2R50
		Write:	UE2T57	UE2T56	UE2T55	UE2T54	UE2T53	UE2T52	UE2T51	UE2T50
		Reset:	Unaffected by reset							

= Unimplemented U = Unaffected by reset

Figure 9-1. USB I/O Register Summary (Sheet 3 of 4)

Addr.	Register Name		Bit 7	6	5	4	3	2	1	Bit 0
\$0036	USB Endpoint 2 Data Register 6 (UE2D6)	Read:	UE2R67	UE2R66	UE2R65	UE2R64	UE2R63	UE2R62	UE2R61	UE2R60
		Write:	UE2T67	UE2T66	UE2T65	UE2T64	UE2T63	UE2T62	UE2T61	UE2T60
		Reset:	Unaffected by reset							
\$0037	USB Endpoint 2 Data Register 7 (UE2D7)	Read:	UE2R77	UE2R76	UE2R75	UE2R74	UE2R73	UE2R72	UE2R71	UE2R70
		Write:	UE2T77	UE2T76	UE2T75	UE2T74	UE2T73	UE2T72	UE2T71	UE2T70
		Reset:	Unaffected by reset							
\$0038	USB Address Register (UADDR)	Read:	USBEN	UADD6	UADD5	UADD4	UADD3	UADD2	UADD1	UADD0
		Write:								
		Reset:	0*	0	0	0	0	0	0	0

* USBEN bit is reset by POR or LVI reset only.

\$0039	USB Interrupt Register 0 (UIR0)	Read:	EOPIE	SUSPND	TXD2IE	RXD2IE	TXD1IE	0	TXD0IE	RXD0IE
		Write:								
		Reset:	0	0	0	0	0	0	0	0
\$003A	USB Interrupt Register 1 (UIR1)	Read:	EOPF	RSTF	TXD2F	RXD2F	TXD1F	RESUMF	TXD0F	RXD0F
		Write:								
		Reset:	0	0	0	0	0	0	0	0
\$003B	USB Control Register 0 (UCR0)	Read:	T0SEQ	0	TX0E	RX0E	TP0SIZ3	TP0SIZ2	TP0SIZ1	TP0SIZ0
		Write:								
		Reset:	0	0	0	0	0	0	0	0
\$003C	USB Control Register 1 (UCR1)	Read:	T1SEQ	STALL1	TX1E	FRESUM	TP1SIZ3	TP1SIZ2	TP1SIZ1	TP1SIZ0
		Write:								
		Reset:	0	0	0	0	0	0	0	0
\$003D	USB Status Register 0 (USR0)	Read:	R0SEQ	SETUP	0	0	RP0SIZ3	RP0SIZ2	RP0SIZ1	RP0SIZ0
		Write:								
		Reset:	Unaffected by reset							
\$003E	USB Status Register 1 (USR1)	Read:	R2SEQ	TXACK	TXNAK	TXSTL	RP2SIZ3	RP2SIZ2	RP2SIZ1	RP2SIZ0
		Write:								
		Reset:	U	0	0	0	U	U	U	U

= Unimplemented U = Unaffected by reset

Figure 9-1. USB I/O Register Summary (Sheet 4 of 4)

9.5 Functional Description

Figure 9-2 shows the block diagram of the USB module. The USB module manages communications between the host and the USB function. The module is partitioned into three functional blocks. These blocks consist of a dual-function transceiver, the USB control logic, and the endpoint registers. The blocks are further detailed later in this section (see **9.7 Hardware Description**).

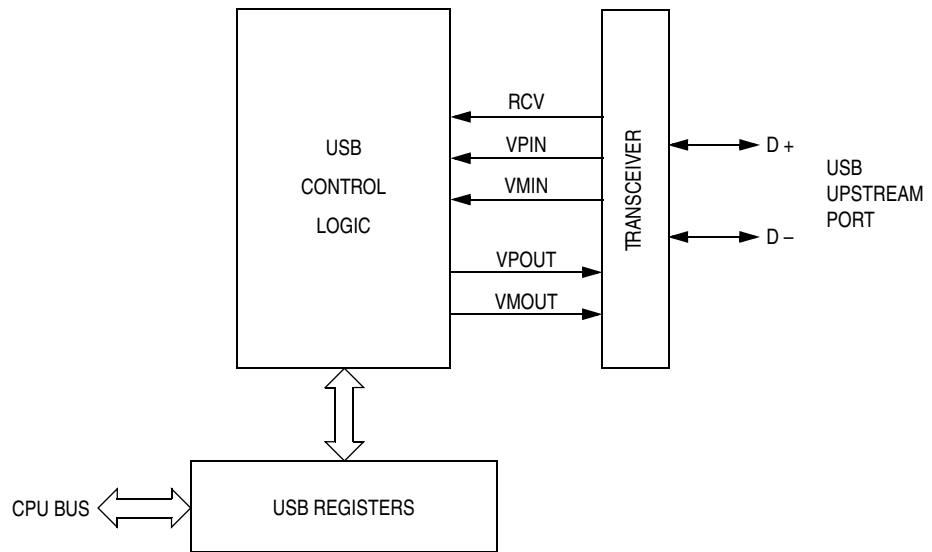

Figure 9-2. USB Block Diagram

9.5.1 USB Protocol

Figure 9-3 shows the various transaction types supported by the USB module. The transactions are portrayed as error free. The effect of errors in the data flow are discussed later.

ENDPOINT 0 TRANSACTIONS:

Control Write

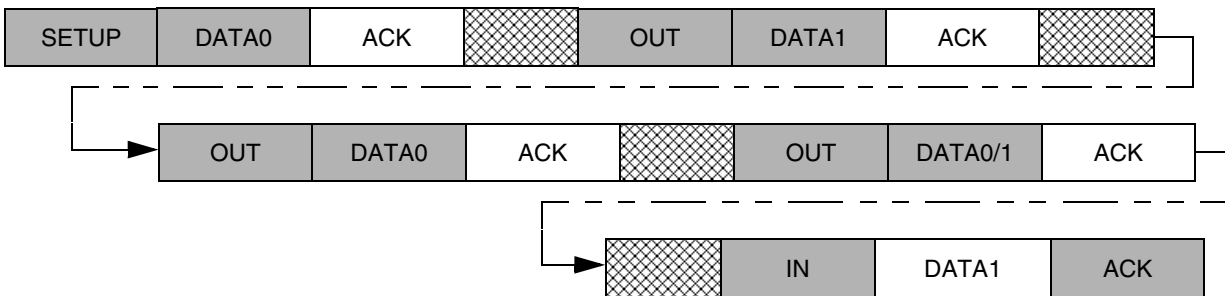

Control Read

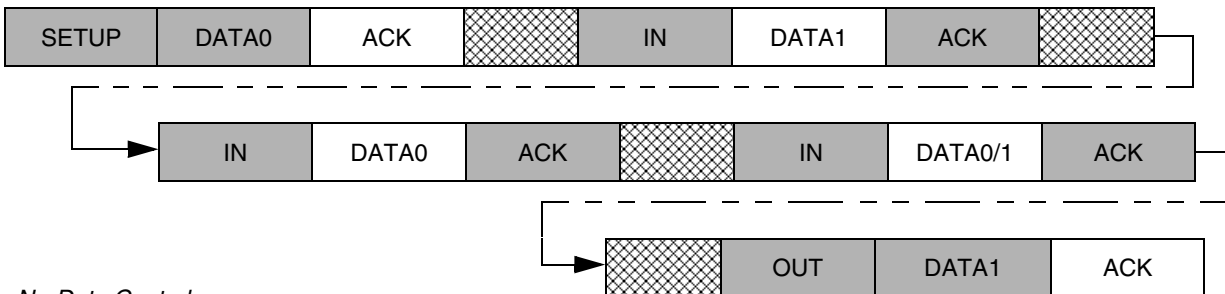

No-Data Control



ENDPOINTS 1 & 2 TRANSACTIONS:

Interrupt

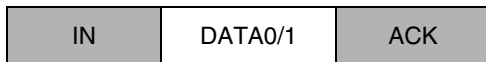

Bulk Transmit

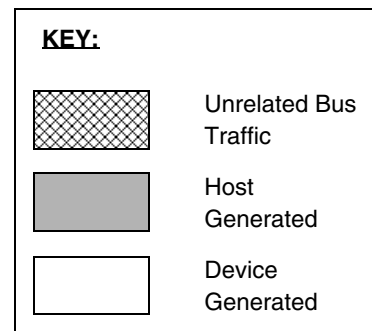
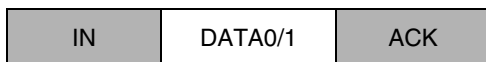

Figure 9-3. Supported Transaction Types Per Endpoint

Each USB transaction is comprised of a series of packets. The USB module supports the packet types shown in **Figure 9-4**. Token packets are generated by the USB host and decoded by the USB device. Data and handshake packets are both decoded and generated by the USB device, depending on the type of transaction.

Token Packet:

IN

OUT

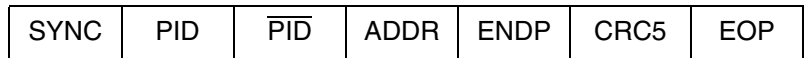

SETUP

Data Packet:

DATA0

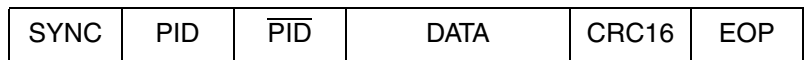

DATA1

0 – 8 Bytes

Handshake Packet:

ACK

NAK

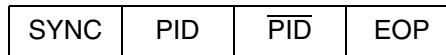

STALL

Figure 9-4. Supported USB Packet Types

The following sections detail each segment used to form a complete USB transaction.

9.5.1.1 Sync Pattern

The NRZI bit pattern shown in **Figure 9-5** is used as a synchronization pattern and is prefixed to each packet. This pattern is equivalent to a data pattern of seven 0s followed by a 1 (\$80).

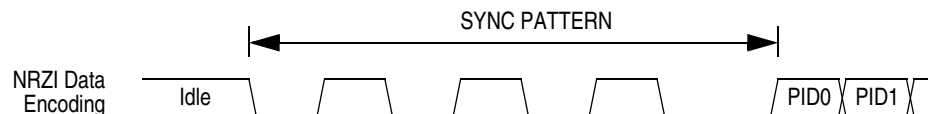

Figure 9-5. Sync Pattern

The start of a packet (SOP) is signaled by the originating port by driving the D+ and D– lines from the idle state (also referred to as the J state) to the opposite logic level (also referred to as the K state). This switch in levels represents the first bit of the sync field. **Figure 9-6** shows the data signaling and voltage levels for the start of packet and the sync pattern.

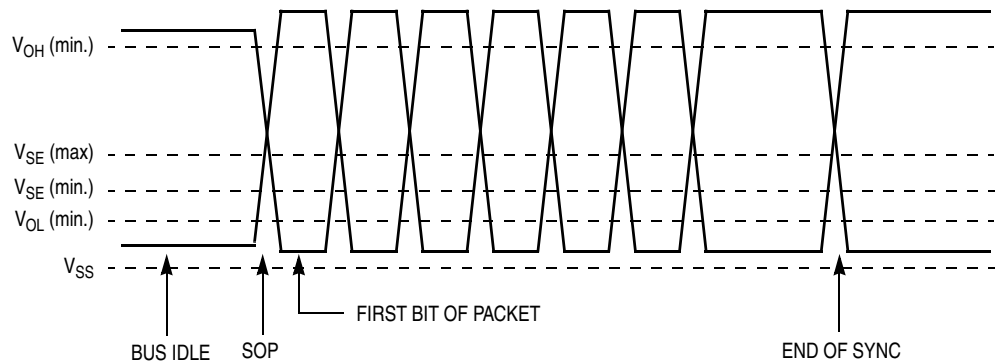

Figure 9-6. SOP, Sync Signaling, and Voltage Levels

9.5.1.2 Packet Identifier Field

The packet identifier field is an 8-bit number comprised of the 4-bit packet identification and its complement. The field follows the sync pattern and determines the direction and type of transaction on the bus. **Table 9-2** shows the packet identifier values for the supported packet types.

Table 9-2. Supported Packet Identifiers

Packet Identifier Value	Packet Identifier Type
%1001	IN Token
%0001	OUT Token
%1101	SETUP Token
%0011	DATA0 Packet
%1011	DATA1 Packet
%0010	ACK Handshake
%1010	NAK Handshake
%1110	STALL Handshake

9.5.1.3 Address Field (ADDR)

The address field is a 7-bit number that is used to select a particular USB device. This field is compared to the lower seven bits of the UADDR register to determine if a given transaction is targeting the MCU USB device.

9.5.1.4 Endpoint Field (ENDP)

The endpoint field is a 4-bit number that is used to select a particular endpoint within a USB device. For the MCU, this will be a binary number between 0 and 2 inclusive. Any other value will cause the transaction to be ignored.

9.5.1.5 Cyclic Redundancy Check (CRC)

Cyclic redundancy checks are used to verify the address and data stream of a USB transaction. This field is five bits wide for token packets and 16 bits wide for data packets. CRCs are generated in the transmitter and sent on the USB data lines after both the endpoint field and the data field.

9.5.1.6 End-of-Packet (EOP)

The single-ended 0 (SE0) state is used to signal an end-of-packet (EOP). The single-ended 0 state is indicated by both D+ and D– being below 0.8V. EOP will be signaled by driving D+ and D– to the single-ended 0 state for two bit times followed by driving the lines to the idle state for one bit time. The transition from the single-ended 0 to the idle state defines the end of the packet. The idle state is asserted for one bit time and then both the D+ and D– output drivers are placed in their high-impedance state. The bus termination resistors hold the bus in the idle state. **Figure 9-7** shows the data signaling and voltage levels for an end-of-packet transaction.

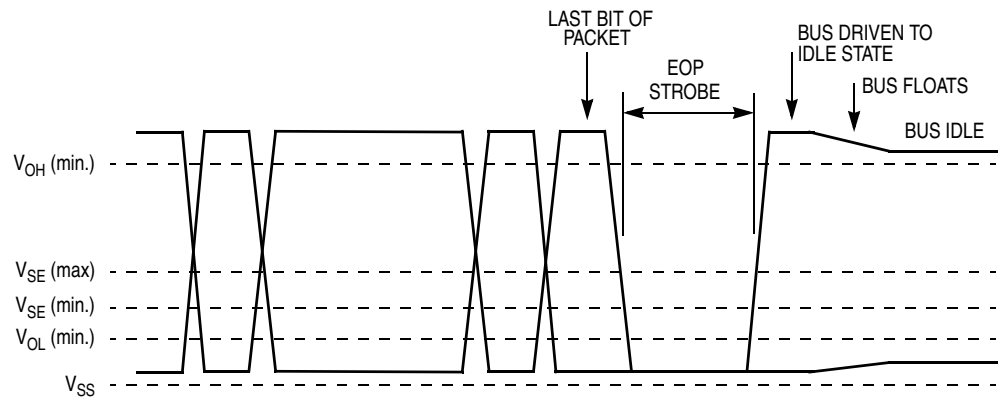

Figure 9-7. EOP Transaction Voltage Levels

The width of the SE0 in the EOP is about two bit times. The EOP width is measured with the same capacitive load used for maximum rise and fall times and is measured at the same level as the differential signal crossover points of the data lines.

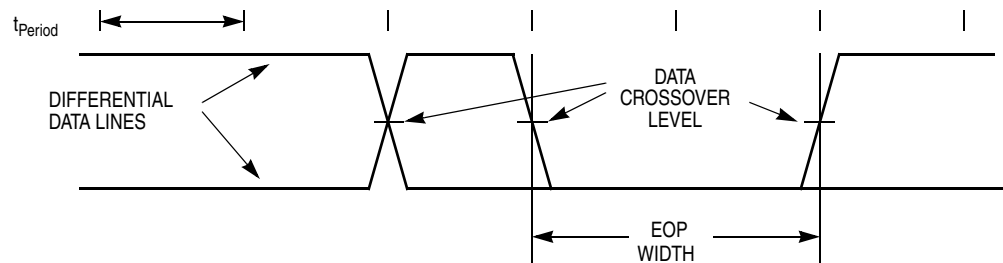

Figure 9-8. EOP Width Timing

9.5.2 Reset Signaling

The USB module will detect a reset signaled on the bus by the presence of an extended SE0 at the USB data pins of a device. The MCU seeing a single-ended 0 on its USB data inputs for more than 8 μ s treats that signal as a reset.

A USB sourced reset will hold the MCU in reset for the duration of the reset on the USB bus. The USB bit in the reset status register (RSR) will be set after the internal reset is removed. Refer to [8.8.2 Reset Status Register](#) for more detail. The MCU's reset recovery sequence is detailed in [Section 8. System Integration Module \(SIM\)](#).

The reset flag bit (RSTF) in the USB interrupt register 1 (UIR1) also will be set after the internal reset is removed. Refer to [9.8.3 USB Interrupt Register 1](#) for more detail.

After a reset is removed, the device will be in the default, but not yet addressed or configured state (refer to Section 9.1 USB Device States of the *Universal Serial Bus Specification* Rev. 1.1). The device must be able to accept a device address via a SET_ADDRESS command (refer to Section 9.4 Standard Device Request in the *Universal Serial Bus Specification* Rev. 1.1) no later than 10 ms after the reset is removed.

Reset can wake a device from the suspended mode.

NOTE: *USB Reset can be configured not to generate a reset signal to the CPU by setting the URSTD bit of the configuration register (see [Section 5. Configuration Register \(CONFIG\)](#)). When a USB reset is detected, the CPU generates an USB interrupt.*

9.5.3 Suspend

The MCU supports suspend mode for low power. Suspend mode should be entered when the USB data lines are in the idle state for more than 3ms. Entry into suspend mode is controlled by the SUSPND bit in the USB interrupt register. Any low-speed bus activity should keep the device out of the suspend state. Low-speed devices are kept awake by periodic low-speed EOP signals from the host. This is referred to as low speed keep alive (refer to Section 11.8.4.1 Low-Speed Keep-alive in the *Universal Serial Bus Specification* Rev. 1.1).

Firmware should monitor the EOPF flag and enter suspend mode by setting the SUSPND bit if an EOP is not detected for 3ms.

Per the USB specification, the bus powered USB system is required to draw less than 500 μ A from the V_{DD} supply when in the suspend state. This includes the current supplied by the voltage regulator to the 1.5k Ω to ground termination resistors placed at the host end of the USB bus. This low-current requirement means that firmware is responsible for entering stop mode once the USB module has been placed in the suspend state.

9.5.4 Resume After Suspend

The MCU can be activated from the suspend state by normal bus activity, a USB reset signal, or by a forced resume driven from the MCU.

9.5.4.1 Host Initiated Resume

The host signals resume by initiating resume signalling (K state) for at least 20ms followed by a standard low-speed EOP signal. This 20ms ensures that all devices in the USB network are awakened.

After resuming the bus, the host must begin sending bus traffic within 37ms to prevent the device from re-entering suspend mode.

9.5.4.2 USB Reset Signalling

Reset can wake a device from the suspended mode.

9.5.4.3 Remote Wakeup

The MCU also supports the remote wakeup feature. The firmware has the ability to exit suspend mode by signaling a resume state to the upstream host or hub. A non-idle state (K state) on the USB data lines is accomplished by asserting the FRESUM bit in the UCR1 register.

When using the remote wakeup capability, the firmware must wait for at least 5ms after the bus is in the idle state before sending the remote wakeup resume signaling. This allows the upstream devices to get into their suspend state and prepare for propagating resume signaling. The FRESUM bit should be asserted to cause the resume state on the USB data lines for at least 10ms, but not more than 15ms. Note that the resume signalling is controlled by the FRESUM bit and meeting the timing specifications is dependent on the firmware. When FRESUM is cleared by firmware, the data lines will return to their high-impedance state.

Refer to the register definitions (see [9.8.6 USB Control Register 1](#)) for more information about how the force resume (FRESUM) bit can be used to initiate the remote wakeup feature.

9.5.5 Low-Speed Device

Low-speed devices are configured by the position of a pull-up resistor on the USB D– pin of the MCU. Low-speed devices are terminated as shown in **Figure 9-9** with the pull-up on the D– line.

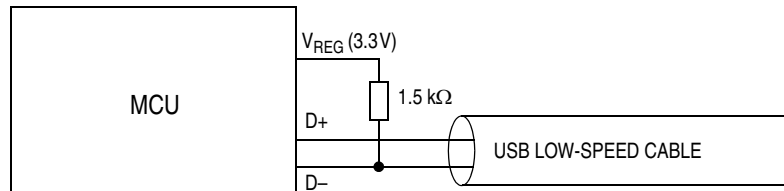

Figure 9-9. External Low-Speed Device Configuration

For low-speed transmissions, the transmitter’s EOP width must be between $1.25\mu\text{s}$ and $1.50\mu\text{s}$. These ranges include timing variations due to differential buffer delay and rise/fall time mismatches and to noise and other random effects. A low-speed receiver must accept a 670ns SE0 followed by a J transition as a valid EOP. An SE0 shorter than 330ns or an SE0 not followed by a J transition are rejected as an EOP. Any SE0 that is $8\mu\text{s}$ or longer is automatically a reset.

9.6 Clock Requirements

The low-speed data rate is nominally 1.5 Mbps. The OSCXCLK signal driven by the oscillator circuits is the clock source for the USB module and requires that a 6-MHz oscillator circuit be connected to the OSC1 and OSC2 pins. The permitted frequency tolerance for low-speed functions is approximately $\pm 1.5\%$ (15,000 ppm). This tolerance includes inaccuracies from all sources: initial frequency accuracy, crystal capacitive loading, supply voltage on the oscillator, temperature, and aging. The jitter in the low-speed data rate must be less than 10ns.

9.7 Hardware Description

The USB module as previously shown in [Figure 9-2](#) contains three functional blocks: the low-speed USB transceiver, the USB control logic, and the USB registers. The following details the function of the regulator, transceiver, and control logic. See [9.8 I/O Registers](#) for details of register settings.

9.7.1 Voltage Regulator

The USB data lines are required by the USB specification to have an output voltage between 2.8V and 3.6V. The data lines also are required to have an external 1.5k Ω pull-up resistor connected between a data line and a voltage source between 3.0V and 3.6V. [Figure 9-10](#) shows the worst case electrical connection for the voltage regulator.

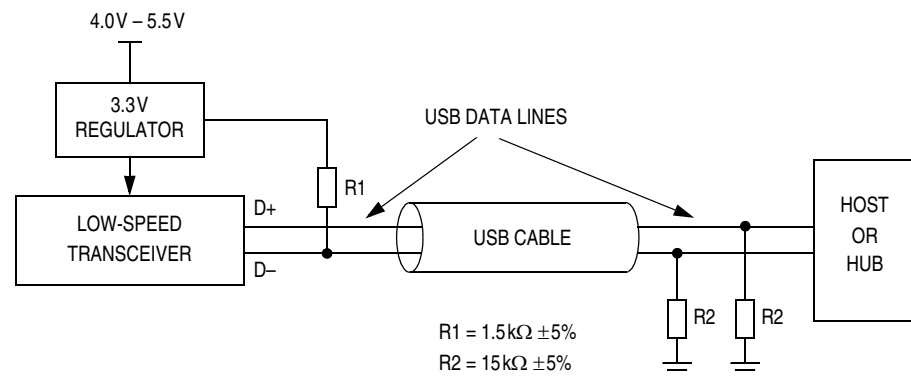

Figure 9-10. Regulator Electrical Connections

9.7.2 USB Transceiver

The USB transceiver provides the physical interface to the USB D+ and D- data lines. The transceiver is composed of two parts: an output drive circuit and a receiver.

9.7.2.1 Output Driver Characteristics

The USB transceiver uses a differential output driver to drive the USB data signal onto the USB cable. The static output swing of the driver in its low state is below the V_{OL} of 0.3V with a 1.5k Ω load to 3.6V and in its high state is above the V_{OH} of 2.8V with a 15k Ω load to ground. The output swings between the differential high and low state are well balanced to minimize signal skew. Slew rate control on the driver is used to minimize the radiated noise and cross talk. The driver's outputs support 3-state operation to achieve bidirectional half duplex operation. The driver can tolerate a voltage on the signal pins of -1.0V to 5.5V with respect to local ground reference without damage.

9.7.2.2 Low Speed (1.5 Mbps) Driver Characteristics

The rise and fall time of the signals on this cable are greater than 75ns and less than 300ns. The edges are matched to within $\pm 20\%$ to minimize RFI emissions and signal skew.

USB data transmission is done with differential signals. A differential input receiver is used to accept the USB data signal. A differential 1 on the bus is represented by D+ being at least 200mV more positive than D- as seen at the receiver, and a differential 0 is represented by D- being at least 200mV more positive than D+ as seen at the receiver. The signal cross over point must be between 1.3V and 2.0V.

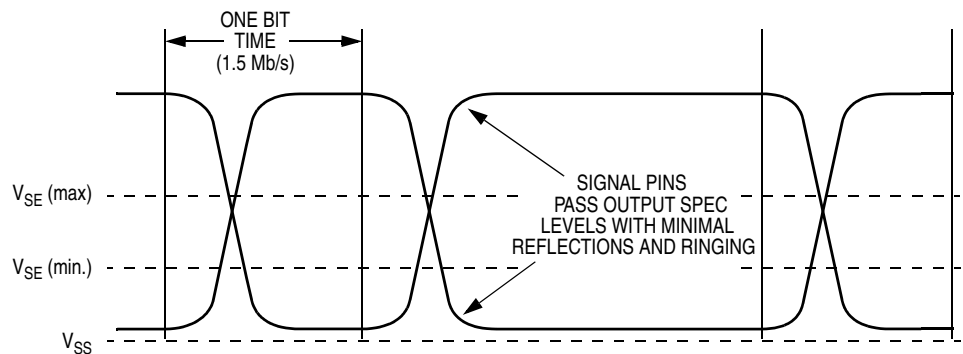

Figure 9-11. Receiver Characteristics

The receiver features an input sensitivity of 200mV when both differential data inputs are in the differential common mode range of 0.8V to 2.5V as shown in [Figure 9-12](#). In addition to the differential receiver, there is a single-ended receiver (schmitt trigger) for each of the two data lines.

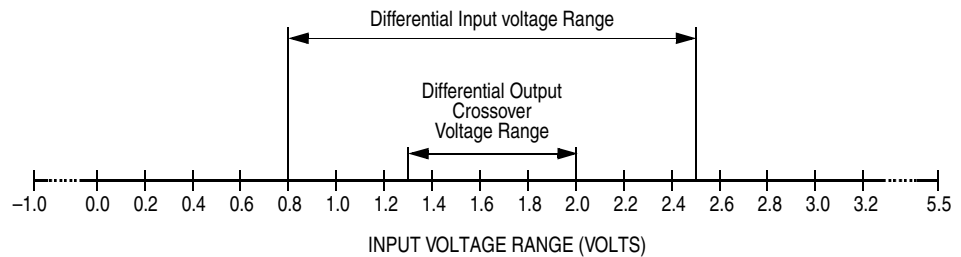

Figure 9-12. Differential Input Sensitivity Range

9.7.2.3 Receiver Data Jitter

The data receivers for all types of devices must be able to properly decode the differential data in the presence of jitter. The more of the bit time that any data edge can occupy and still be decoded, the more reliable the data transfer will be. Data receivers are required to decode differential data transitions that occur in a window plus and minus a nominal quarter bit time from the nominal (centered) data edge position.

Jitter will be caused by the delay mismatches and by mismatches in the source and destination data rates (frequencies). The receive data jitter budget for low speed is given in [Section 18. Electrical Specifications](#). The specification includes the consecutive (next) and paired transition values for each source of jitter.

9.7.2.4 Data Source Jitter

The source of data can have some variation (jitter) in the timing of edges of the data transmitted. The time between any set of data transitions is $N \times T_{\text{Period}} \pm \text{jitter time}$, where N is the number of bits between the transitions and T_{Period} is defined as the actual period of the data rate. The data jitter is measured with the same capacitive load used for maximum rise and fall times and is measured at the crossover points of the data lines as shown in [Figure 9-13](#).

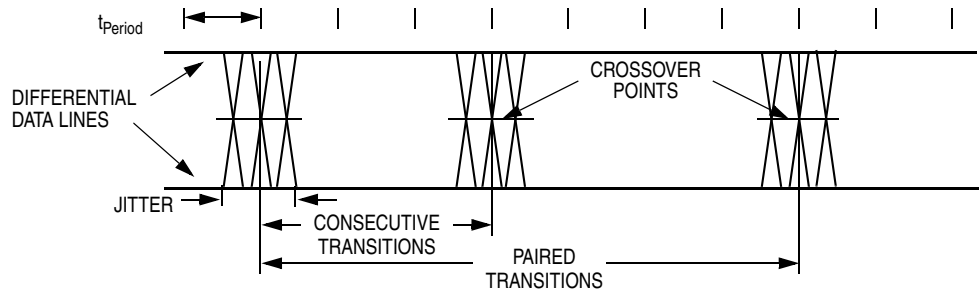

Figure 9-13. Data Jitter

For low-speed transmissions, the jitter time for any consecutive differential data transitions must be within $\pm 25\text{ns}$ and within $\pm 10\text{ns}$ for any set of paired differential data transitions. These jitter numbers include timing variations due to differential buffer delay, rise/fall time mismatches, internal clock source jitter, noise and other random effects.

9.7.2.5 Data Signal Rise and Fall Time

The output rise time and fall time are measured between 10% and 90% of the signal. Edge transition time for the rising and falling edges of low-speed signals is 75ns (minimum) into a capacitive load (C_L) of 200pF and 300ns (maximum) into a capacitive load of 600pF. The rising and falling edges should be transitioning (monotonic) smoothly when driving the cable to avoid excessive EMI.

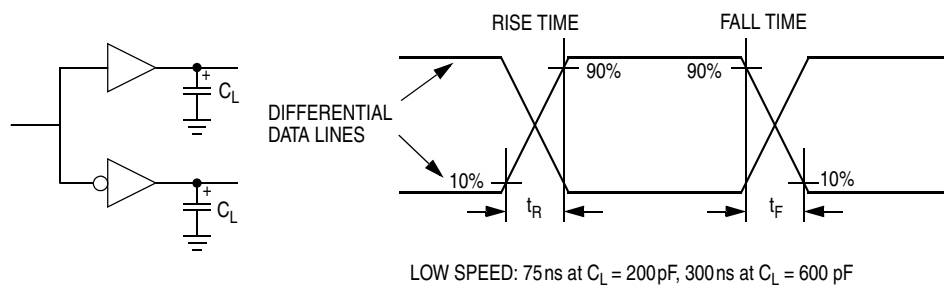

Figure 9-14. Data Signal Rise and Fall Time

9.7.3 USB Control Logic

The USB control logic manages data movement between the CPU and the transceiver. The control logic handles both transmit and receive operations on the USB. It contains the logic used to manipulate the transceiver and the endpoint registers.

The byte count buffer is loaded with the active transmit endpoints byte count value during transmit operations. This same buffer is used for receive transactions to count the number of bytes received and, upon the end of the transaction, transfer that number to the receive endpoints byte count register.

When transmitting, the control logic handles parallel-to-serial conversion, CRC generation, NRZI encoding, and bit stuffing.

When receiving, the control logic handles sync detection, packet identification, end-of-packet detection, bit (un)stuffing, NRZI decoding, CRC validation, and serial-to-parallel conversion. Errors detected by the control logic include bad CRC, timeout while waiting for EOP, and bit stuffing violations.

9.8 I/O Registers

These I/O registers control and monitor USB operation:

- USB address register (UADDR)
- USB control registers 0–4 (UCR0–UCR4)
- USB status registers 0–1 (USR0–USR1)
- USB interrupt registers 0–2 (UIR0–UIR2)
- USB endpoint 0 data registers 0–7 (UE0D0–UE0D7)
- USB endpoint 1 data registers 0–7 (UE1D0–UE1D7)
- USB endpoint 2 data registers 0–7 (UE2D0–UE2D7)

9.8.1 USB Address Register

Address: \$0038

	Bit 7	6	5	4	3	2	1	Bit 0
Read:								
Write:	USBEN	UADD6	UADD5	UADD4	UADD3	UADD2	UADD1	UADD0
Reset:	0*	0	0	0	0	0	0	0

* USBEN bit is reset by POR or LVI reset only.

Figure 9-15. USB Address Register (UADDR)

USBEN — USB Module Enable

This read/write bit enables and disables the USB module and the USB pins. When USBEN is set, the USB module is enabled and the PTE4 interrupt is disabled. When USBEN is clear, the USB module will not respond to any tokens, USB reset and USB related interrupts are disabled, and pins PTE4/D– and PTE3/D+ function as high current open-drain I/O port pins PTE4 and PTE3.

1 = USB function enabled and PTE4 interrupt is disabled

0 = USB function disabled including USB interrupt, reset and reset interrupt

UADD[6:0] — USB Function Address

These bits specify the USB address of the device. Reset clears these bits.

9.8.2 USB Interrupt Register 0

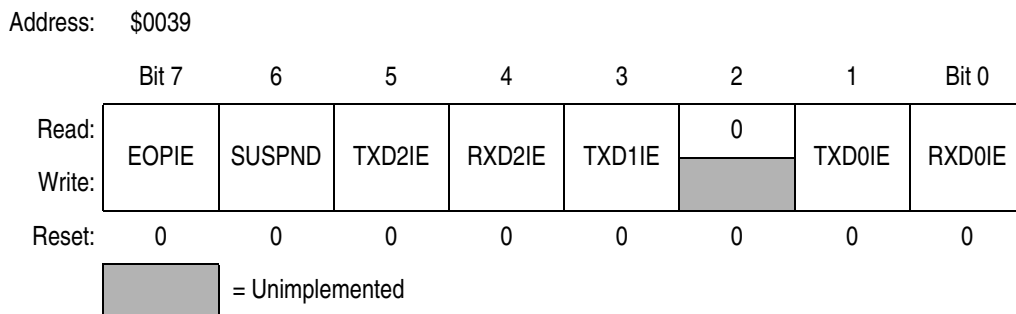

Figure 9-16. USB Interrupt Register 0 (UIR0)

EOPIE — End-of-Packet Detect Interrupt Enable

This read/write bit enables the USB to generate CPU interrupt requests when the EOPF bit becomes set. Reset clears the EOPIE bit.

- 1 = End-of-packet sequence detection can generate a CPU interrupt request
- 0 = End-of-packet sequence detection cannot generate a CPU interrupt request

SUSPND — USB Suspend Bit

To save power, this read/write bit should be set by the software if a 3ms constant idle state is detected on the USB bus. Setting this bit puts the transceiver into a power-saving mode. The RESUMF flag must be cleared before setting SUSPND. Software must clear this bit after the resume flag (RESUMF) is set while this resume interrupt flag is serviced.

TXD2IE — Endpoint 2 Transmit Interrupt Enable

This read/write bit enables the transmit endpoint 2 to generate CPU interrupt requests when the TXD2F bit becomes set. Reset clears the TXD2IE bit.

- 1 = Transmit endpoint 2 can generate a CPU interrupt request
- 0 = Transmit endpoint 2 cannot generate a CPU interrupt request

RXD2IE — Endpoint 2 Receive Interrupt Enable

This read/write bit enables the receive endpoint 2 to generate CPU interrupt requests when the RXD2F bit becomes set. Reset clears the RXD2IE bit.

- 1 = Receive endpoint 2 can generate a CPU interrupt request
- 0 = Receive endpoint 2 cannot generate a CPU interrupt request

TXD1IE — Endpoint 1 Transmit Interrupt Enable

This read/write bit enables the transmit endpoint 1 to generate CPU interrupt requests when the TXD1F bit becomes set. Reset clears the TXD1IE bit.

- 1 = Transmit endpoints 1 can generate a CPU interrupt request
- 0 = Transmit endpoints 1 cannot generate a CPU interrupt request

TXD0IE — Endpoint 0 Transmit Interrupt Enable

This read/write bit enables the transmit endpoint 0 to generate CPU interrupt requests when the TXD0F bit becomes set. Reset clears the TXD0IE bit.

- 1 = Transmit endpoint 0 can generate a CPU interrupt request
- 0 = Transmit endpoint 0 cannot generate a CPU interrupt request

RXD0IE — Endpoint 0 Receive Interrupt Enable

This read/write bit enables the receive endpoint 0 to generate CPU interrupt requests when the RXD0F bit becomes set. Reset clears the RXD0IE bit.

- 1 = Receive endpoint 0 can generate a CPU interrupt request
- 0 = Receive endpoint 0 cannot generate a CPU interrupt request

9.8.3 USB Interrupt Register 1

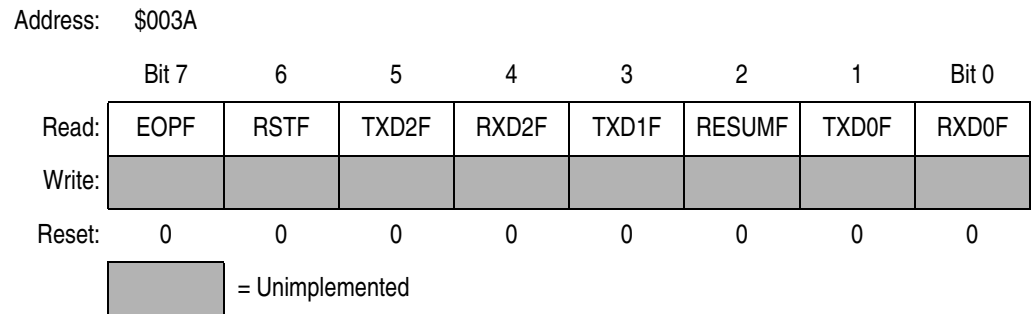

Figure 9-17. USB Interrupt Register 1 (UIR1)

EOPF — End-of-Packet Detect Flag

This read-only bit is set when a valid end-of-packet sequence is detected on the D+ and D– lines. Software must clear this flag by writing a logic 1 to the EOPFR bit.

Reset clears this bit. Writing to EOPF has no effect.

1 = End-of-packet sequence has been detected

0 = End-of-packet sequence has not been detected

RSTF — USB Reset Flag

This read-only bit is set when a valid reset signal state is detected on the D+ and D– lines. If the URSTD bit of the configuration register (CONFIG) is clear, this reset detection will generate an internal reset signal to reset the CPU and other peripherals including the USB module. If the URSTD bit is set, this reset detection will generate an USB interrupt. This bit is cleared by writing a logic 1 to the RSTFR bit. This bit also is cleared by a POR reset.

NOTE: *The USB bit in the RSR register (see [8.8.2 Reset Status Register](#)) is also a USB reset indicator.*

TXD2F — Endpoint 2 Data Transmit Flag

This read-only bit is set after the data stored in endpoint 2 transmit buffers has been sent and an ACK handshake packet from the host is received. Once the next set of data is ready in the transmit buffers, software must clear this flag by writing a logic 1 to the TXD2FR bit.

To enable the next data packet transmission, TX2E also must be set. If the TXD2F bit is not cleared, a NAK handshake will be returned in the next IN transaction.

Reset clears this bit. Writing to TXD2F has no effect.

- 1 = Transmit on endpoint 2 has occurred
- 0 = Transmit on endpoint 2 has not occurred

RXD2F — Endpoint 2 Data Receive Flag

This read-only bit is set after the USB module has received a data packet and responded with an ACK handshake packet. Software must clear this flag by writing a logic 1 to the RXD2FR bit after all of the received data has been read. Software also must set the RX2E bit to 1 to enable the next data packet reception. If the RXD2F bit is not cleared, a NAK handshake will be returned in the next OUT transaction.

Reset clears this bit. Writing to RXD2F has no effect.

- 1 = Receive on endpoint 2 has occurred
- 0 = Receive on endpoint 2 has not occurred

TXD1F — Endpoint 1 Data Transmit Flag

This read-only bit is set after the data stored in the endpoint 1 transmit buffer has been sent and an ACK handshake packet from the host is received. Once the next set of data is ready in the transmit buffers, software must clear this flag by writing a logic 1 to the TXD1FR bit. To enable the next data packet transmission, TX1E also must be set. If the TXD1F bit is not cleared, a NAK handshake will be returned in the next IN transaction.

Reset clears this bit. Writing to TXD1F has no effect.

- 1 = Transmit on endpoint 1 has occurred
- 0 = Transmit on endpoint 1 has not occurred

RESUMF — Resume Flag

This read-only bit is set when USB bus activity is detected while the SUSPND bit is set. Software must clear this flag by writing a logic 1 to the RESUMFR bit. Reset clears this bit. Writing a logic 0 to RESUMF has no effect.

- 1 = USB bus activity has been detected
- 0 = No USB bus activity has been detected

TXD0F — Endpoint 0 Data Transmit Flag

This read-only bit is set after the data stored in endpoint 0 transmit buffers has been sent and an ACK handshake packet from the host is received. Once the next set of data is ready in the transmit buffers, software must clear this flag by writing a logic 1 to the TXD0FR bit. To enable the next data packet transmission, TX0E also must be set. If the TXD0F bit is not cleared, a NAK handshake will be returned in the next IN transaction.

Reset clears this bit. Writing to TXD0F has no effect.

1 = Transmit on endpoint 0 has occurred

0 = Transmit on endpoint 0 has not occurred

RXD0F — Endpoint 0 Data Receive Flag

This read-only bit is set after the USB module has received a data packet and responded with an ACK handshake packet. Software must clear this flag by writing a logic 1 to the RXD0FR bit after all of the received data has been read. Software also must set the RX0E bit to 1 to enable the next data packet reception. If the RXD0F bit is not cleared, the USB will respond with a NAK handshake to any endpoint 0 OUT tokens; but does not respond to a SETUP token.

Reset clears this bit. Writing to RXD0F has no effect.

1 = Receive on endpoint 0 has occurred

0 = Receive on endpoint 0 has not occurred

9.8.4 USB Interrupt Register 2

Address: \$0018

	Bit 7	6	5	4	3	2	1	Bit 0
Read:	0	0	0	0	0	0	0	0
Write:	EOPFR	RSTFR	TXD2FR	RXD2FR	TXD1FR	RESUMFR	TXD0FR	RXD0FR
Reset:	0	0	0	0	0	0	0	0

Figure 9-18. USB Interrupt Register 2 (UIR2)

EOPFR — End-of-Packet Flag Reset

Writing a logic 1 to this write-only bit will clear the EOPF bit if it is set. Writing a logic 0 to the EOPFR has no effect. Reset clears this bit.

RSTFR — Clear Reset Indicator Bit

Writing a logic 1 to this write-only bit will clear the RSTF bit if it is set. Writing a logic 0 to the RSTFR has no effect. Reset clears this bit.

TXD2FR — Endpoint 2 Transmit Flag Reset

Writing a logic 1 to this write-only bit will clear the TXD2F bit if it is set. Writing a logic 0 to TXD2FR has no effect. Reset clears this bit.

RXD2FR — Endpoint 2 Receive Flag Reset

Writing a logic 1 to this write-only bit will clear the RXD2F bit if it is set. Writing a logic 0 to RXD2FR has no effect. Reset clears this bit.

TXD1FR — Endpoint 1 Transmit Flag Reset

Writing a logic 1 to this write-only bit will clear the TXD1F bit if it is set. Writing a logic 0 to TXD1FR has no effect. Reset clears this bit.

RESUMFR — Resume Flag Reset

Writing a logic 1 to this write-only bit will clear the RESUMF bit if it is set. Writing to RESUMFR has no effect. Reset clears this bit.

TXD0FR — Endpoint 0 Transmit Flag Reset

Writing a logic 1 to this write-only bit will clear the TXD0F bit if it is set. Writing a logic 0 to TXD0FR has no effect. Reset clears this bit.

RXD0FR — Endpoint 0 Receive Flag Reset

Writing a logic 1 to this write-only bit will clear the RXD0F bit if it is set. Writing a logic 0 to RXD0FR has no effect. Reset clears this bit.

9.8.5 USB Control Register 0

Address: \$003B

	Bit 7	6	5	4	3	2	1	Bit 0
Read:		0						
Write:	T0SEQ		TX0E	RX0E	TP0SIZ3	TP0SIZ2	TP0SIZ1	TP0SIZ0
Reset:	0	0	0	0	0	0	0	0

Figure 9-19. USB Control Register 0 (UCR0)

T0SEQ — Endpoint 0 Transmit Sequence Bit

This read/write bit determines which type of data packet (DATA0 or DATA1) will be sent during the next IN transaction directed at endpoint 0. Toggling of this bit must be controlled by software. Reset clears this bit.

- 1 = DATA1 token active for next endpoint 0 transmit
- 0 = DATA0 token active for next endpoint 0 transmit

TX0E — Endpoint 0 Transmit Enable

This read/write bit enables a transmit to occur when the USB host controller sends an IN token to endpoint 0. Software should set this bit when data is ready to be transmitted. It must be cleared by software when no more endpoint 0 data needs to be transmitted.

If this bit is 0 or the TXD0F is set, the USB will respond with a NAK handshake to any endpoint 0 IN tokens. Reset clears this bit.

- 1 = Data is ready to be sent
- 0 = Data is not ready. Respond with NAK

RX0E — Endpoint 0 Receive Enable

This read/write bit enables a receive to occur when the USB host controller sends an OUT token to endpoint 0. Software should set this bit when data is ready to be received. It must be cleared by software when data cannot be received.

If this bit is 0 or the RXD0F is set, the USB will respond with a NAK handshake to any endpoint 0 OUT tokens; but does not respond to a SETUP token. Reset clears this bit.

- 1 = Data is ready to be received
- 0 = Not ready for data. Respond with NAK

TP0SIZ3–TP0SIZ0 — Endpoint 0 Transmit Data Packet Size

These read/write bits store the number of transmit data bytes for the next IN token request for endpoint 0. These bits are cleared by reset.

9.8.6 USB Control Register 1

Address: \$003C

	Bit 7	6	5	4	3	2	1	Bit 0
Read:	T1SEQ	STALL1	TX1E	FRESUM	TP1SIZ3	TP1SIZ2	TP1SIZ1	TP1SIZ0
Write:								
Reset:	0	0	0	0	0	0	0	0

Figure 9-20. USB Control Register 1 (UCR1)

T1SEQ — Endpoint 1 Transmit Sequence Bit

This read/write bit determines which type of data packet (DATA0 or DATA1) will be sent during the next IN transaction directed to endpoint 1. Toggling of this bit must be controlled by software. Reset clears this bit.

- 1 = DATA1 token active for next endpoint 1 transmit
- 0 = DATA0 token active for next endpoint 1 transmit

STALL1 — Endpoint 1 Force Stall Bit

This read/write bit causes endpoint 1 to return a STALL handshake when polled by either an IN or OUT token by the USB host controller. Reset clears this bit.

- 1 = Send STALL handshake
- 0 = Default

TX1E — Endpoint 1 Transmit Enable

This read/write bit enables a transmit to occur when the USB host controller sends an IN token to endpoint 1. The appropriate endpoint enable bit, ENABLE1 bit in the UCR3 register, also should be set. Software should set the TX1E bit when data is ready to be transmitted. It must be cleared by software when no more data needs to be transmitted.

If this bit is 0 or the TXD1F is set, the USB will respond with a NAK handshake to any endpoint 1 directed IN tokens. Reset clears this bit.

1 = Data is ready to be sent

0 = Data is not ready. Respond with NAK

FRESUM — Force Resume

This read/write bit forces a resume state (K or non-idle state) onto the USB data lines to initiate a remote wakeup. Software should control the timing of the forced resume to be between 10 and 15 ms. Setting this bit will not cause the RESUMF bit to be set.

1 = Force data lines to K state

0 = Default

TP1SIZ3–TP1SIZ0 — Endpoint 1 Transmit Data Packet Size

These read/write bits store the number of transmit data bytes for the next IN token request for endpoint 1. These bits are cleared by reset.

9.8.7 USB Control Register 2

Address: \$0019

	Bit 7	6	5	4	3	2	1	Bit 0
Read:	T2SEQ	STALL2	TX2E	RX2E	TP2SIZ3	TP2SIZ2	TP2SIZ1	TP2SIZ0
Write:								
Reset:	0	0	0	0	0	0	0	0

Figure 9-21. USB Control Register 2 (UCR2)

T2SEQ — Endpoint 2 Transmit Sequence Bit

This read/write bit determines which type of data packet (DATA0 or DATA1) will be sent during the next IN transaction directed to endpoint 2. Toggling of this bit must be controlled by software. Reset clears this bit.

1 = DATA1 token active for next endpoint 2 transmit

0 = DATA0 token active for next endpoint 2 transmit

STALL2 — Endpoint 2 Force Stall Bit

This read/write bit causes endpoint 2 to return a STALL handshake when polled by either an IN or OUT token by the USB host controller. Reset clears this bit.

- 1 = Send STALL handshake
- 0 = Default

TX2E — Endpoint 2 Transmit Enable

This read/write bit enables a transmit to occur when the USB host controller sends an IN token to endpoint 2. The appropriate endpoint enable bit, ENABLE2 bit in the UCR3 register, also should be set. Software should set the TX2E bit when data is ready to be transmitted. It must be cleared by software when no more data needs to be transmitted.

If this bit is 0 or the TXD2F is set, the USB will respond with a NAK handshake to any endpoint 2 directed IN tokens. Reset clears this bit.

- 1 = Data is ready to be sent
- 0 = Data is not ready. Respond with NAK

RX2E — Endpoint 2 Receive Enable

This read/write bit enables a receive to occur when the USB host controller sends an OUT token to endpoint 2. Software should set this bit when data is ready to be received. It must be cleared by software when data cannot be received.

If this bit is 0 or the RXD2F is set, the USB will respond with a NAK handshake to any endpoint 2 OUT tokens. Reset clears this bit.

- 1 = Data is ready to be received
- 0 = Not ready for data. Respond with NAK

TP2SIZ3–TP2SIZ0 — Endpoint 2 Transmit Data Packet Size

These read/write bits store the number of transmit data bytes for the next IN token request for endpoint 2. These bits are cleared by reset.

9.8.8 USB Control Register 3

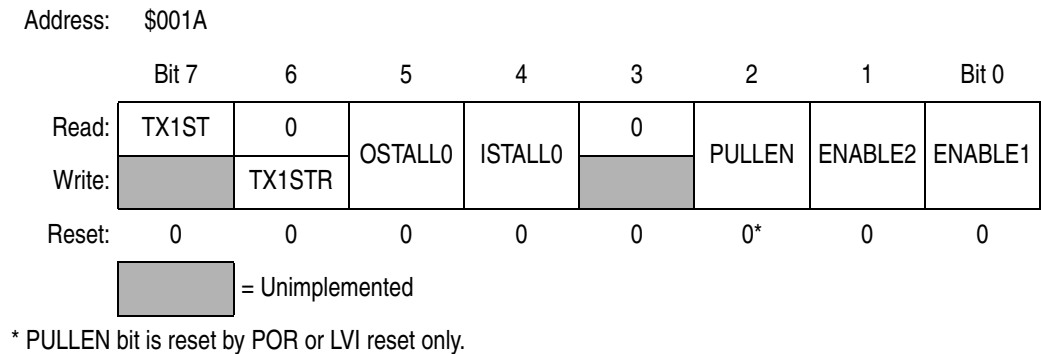

Figure 9-22. USB Control Register 3 (UCR3)

TX1ST — Endpoint 0 Transmit First Flag

This read-only bit is set if the endpoint 0 data transmit flag (TXD0F) is set when the USB control logic is setting the endpoint 0 data receive flag (RXD0F). In other words, if an unserviced endpoint 0 transmit flag is still set at the end of an endpoint 0 reception, then this bit will be set. This bit lets the firmware know that the endpoint 0 transmission happened before the endpoint 0 reception.

Reset clears this bit.

- 1 = IN transaction occurred before SETUP/OUT
- 0 = IN transaction occurred after SETUP/OUT

TX1STR — Clear Endpoint 0 Transmit First Flag

Writing a logic 1 to this write-only bit will clear the TX1ST bit if it is set. Writing a logic 0 to the TX1STR has no effect. Reset clears this bit.

OSTALL0 — Endpoint 0 Force STALL Bit for OUT token

This read/write bit causes endpoint 0 to return a STALL handshake when polled by an OUT token by the USB host controller. Reset clears this bit.

- 1 = Send STALL handshake
- 0 = Default

ISTALL0 — Endpoint 0 Force STALL Bit for IN token

This read/write bit causes endpoint 0 to return a STALL handshake when polled by an IN token by the USB host controller.

Reset clears this bit.

1 = Send STALL handshake

0 = Default

PULLEN — Pull-up Enable

This read/write bit controls the pull-up option for the USB D– pin if the USB module is enabled.

1 = Configure D– pin to have internal pull-up

0 = Disconnect D– pin internal pull-up

ENABLE2 — Endpoint 2 Enable

This read/write bit enables endpoint 2 and allows the USB to respond to IN or OUT packets addressed to endpoint 2. Reset clears this bit.

1 = Endpoint 2 is enabled and can respond to an IN or OUT token

0 = Endpoint 2 is disabled

ENABLE1 — Endpoint 1 Enable

This read/write bit enables endpoint 1 and allows the USB to respond to IN packets addressed to endpoint 1. Reset clears this bit.

1 = Endpoint 1 is enabled and can respond to an IN token

0 = Endpoint 1 is disabled

9.8.9 USB Control Register 4

USB control register 4 directly controls the USB data pins D+ and D-. If the FUSBO bit, and the USBEN bit of the USB address register (UADDR) are set, the output buffers of the USB modules are enabled and the corresponding levels of the USB data pins D+ and D- are equal to the values set by the FDP and the FDM bits.

Address: \$001B

	Bit 7	6	5	4	3	2	1	Bit 0
Read:	0	0	0	0	0	FUSBO	FDP	FDM
Write:								
Reset:	0	0	0	0	0	0	0	0

= Unimplemented

Figure 9-23. USB Control Register 4 (UCR4)

FUSBO — Force USB Output

This read/write bit enables the USB output buffers.

1 = Enables USB output buffers

0 = USB module in normal operation

FDP — Force D+

This read/write bit determinates the output level of D+.

1 = D+ at output high level

0 = D+ at output low level

FDM — Force D-

This read/write bit determinates the output level of D-.

1 = D- at output high level

0 = D- at output low level

NOTE: *Customers must be very careful when setting the UCR4 register. When the FUSBO and the USBEN bits are set, the USB module is in output mode and it will not recognize any USB signals including the USB reset signal. The UCR4 register is used for some special applications. Customers are not normally expected to use this register.*

9.8.10 USB Status Register 0

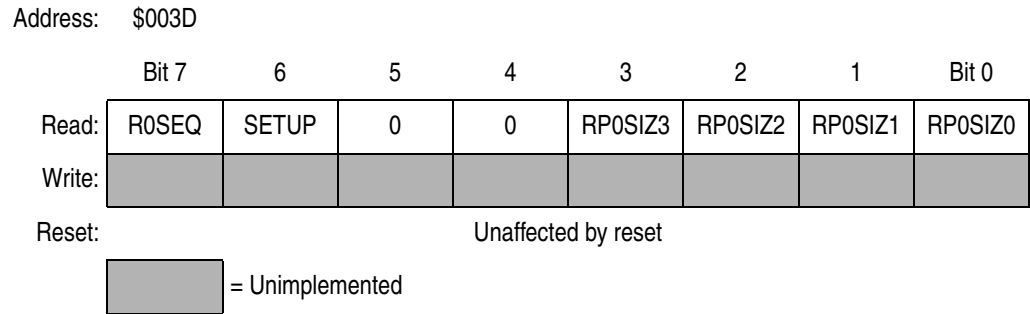

Figure 9-24. USB Status Register 0 (USR0)

R0SEQ — Endpoint 0 Receive Sequence Bit

This read-only bit indicates the type of data packet last received for endpoint 0 (DATA0 or DATA1).

- 1 = DATA1 token received in last endpoint 0 receive
- 0 = DATA0 token received in last endpoint 0 receive

SETUP — SETUP Token Detect Bit

This read-only bit indicates that a valid SETUP token has been received.

- 1 = Last token received for endpoint 0 was a SETUP token
- 0 = Last token received for endpoint 0 was not a SETUP token

RP0SIZ3–RP0SIZ0 — Endpoint 0 Receive Data Packet Size

These read-only bits store the number of data bytes received for the last OUT or SETUP transaction for endpoint 0.

9.8.11 USB Status Register 1

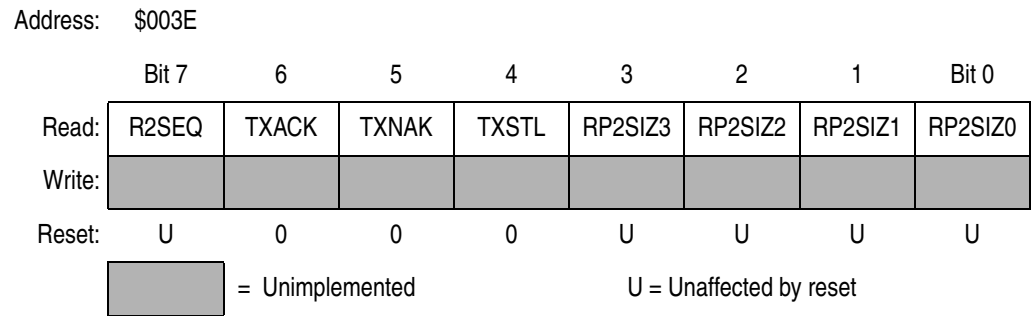

Figure 9-25. USB Status Register 1 (USR1)

R2SEQ — Endpoint 2 Receive Sequence Bit

This read-only bit indicates the type of data packet last received for endpoint 2 (DATA0 or DATA1).

- 1 = DATA1 token received in last endpoint 2 receive
- 0 = DATA0 token received in last endpoint 2 receive

TXACK — ACK Token Transmit Bit

This read-only bit indicates that an ACK token has been transmitted. This bit is updated at the end of the EP0 data transmission.

- 1 = Last token transmitted for endpoint 0 was an ACK token
- 0 = Last token transmitted for endpoint 0 was not an ACK token

TXNAK — NAK Token Transmit Bit

This read-only bit indicates that a TXNAK token has been transmitted. This bit is updated at the end of the EP0 data transmission.

- 1 = Last token transmitted for endpoint 0 was a NAK token
- 0 = Last token transmitted for endpoint 0 was not a NAK token

TXSTL — STALL Token Transmit Bit

This read-only bit indicates that a STALL token has been transmitted. This bit is updated at the end of the EP0 data transmission.

- 1 = Last token transmitted for endpoint 0 was a STALL token
- 0 = Last token transmitted for endpoint 0 was not a STALL token

RP2SIZ3–RP2SIZ0 — Endpoint 2 Receive Data Packet Size

These read-only bits store the number of data bytes received for the last OUT transaction for endpoint 2.

9.8.12 USB Endpoint 0 Data Registers

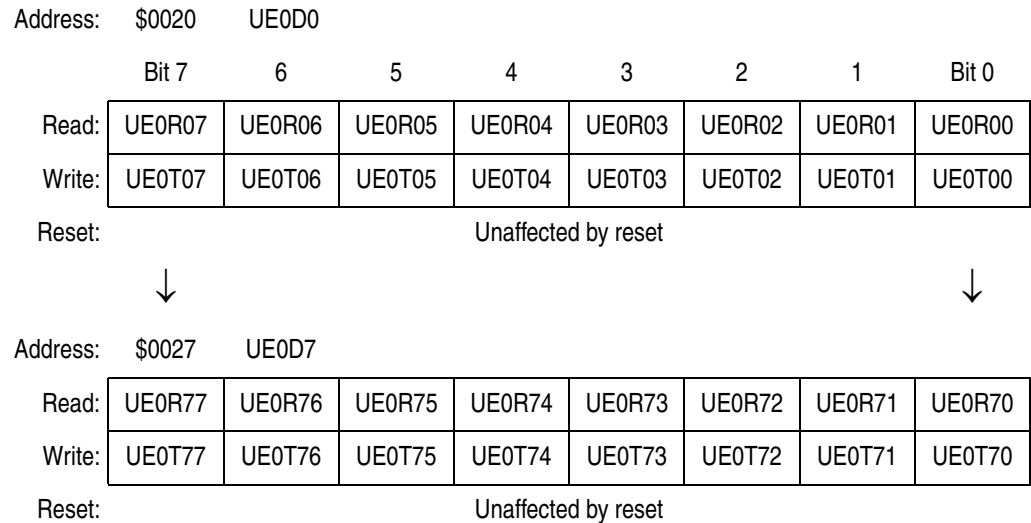

Figure 9-26. USB Endpoint 0 Data Registers (UE0D0–UE0D7)

UE0Rx7–UE0Rx0 — Endpoint 0 Receive Data Buffer

These read-only bits are serially loaded with OUT token or SETUP token data directed at endpoint 0. The data is received over the USB’s D+ and D– pins.

UE0Tx7–UE0Tx0 — Endpoint 0 Transmit Data Buffer

These write-only buffers are loaded by software with data to be sent on the USB bus on the next IN token directed at endpoint 0.

9.8.13 USB Endpoint 1 Data Registers

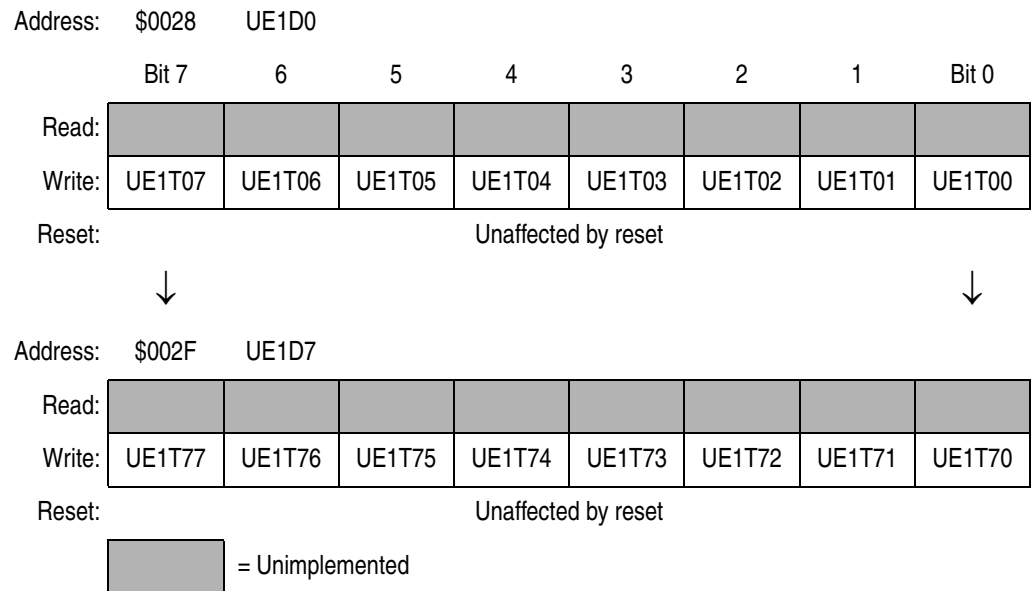

Figure 9-27. USB Endpoint 1 Data Registers (UE1D0–UE1D7)

UE1Tx7–UE1Tx0 — Endpoint 1 Transmit or Receive Data Buffer

These write-only buffers are loaded by software with data to be sent on the USB bus on the next IN token directed at endpoint 1.

9.8.14 USB Endpoint 2 Data Registers

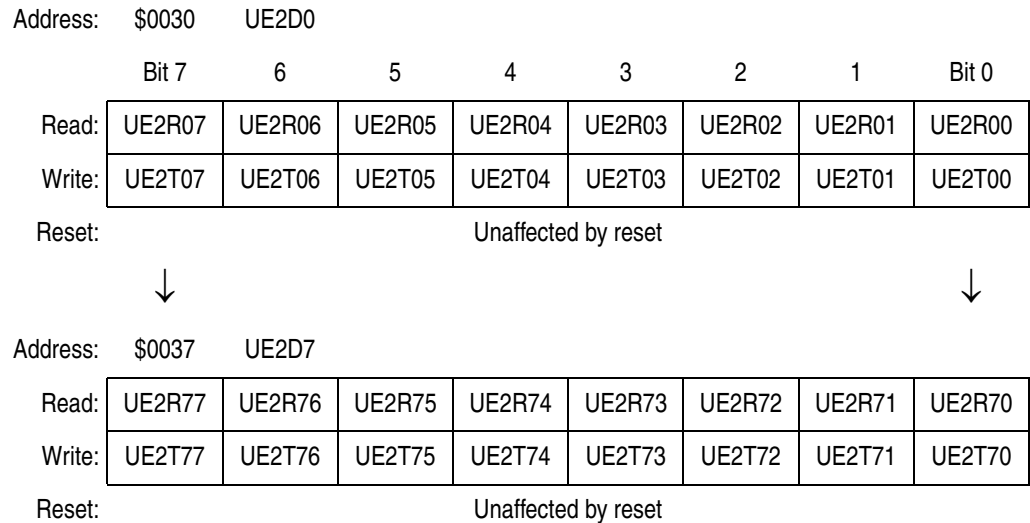

Figure 9-28. USB Endpoint 2 Data Registers (UE2D0–UE2D7)

UE2Rx7–UE2Rx0 — Endpoint 2 Receive Data Buffer

These read-only bits are serially loaded with OUT token data directed at endpoint 2. The data is received over the USB’s D+ and D– pins.

UE2Tx7–UE2Tx0 — Endpoint 2 Transmit Data Buffer

These write-only buffers are loaded by software with data to be sent on the USB bus on the next IN token directed at endpoint 2.

9.9 USB Interrupts

The USB module is capable of generating interrupts and causing the CPU to execute the USB interrupt service routine. There are three types of USB interrupts:

- End-of-transaction interrupts signify either a completed transaction receive or transmit transaction.
- Resume interrupts signify that the USB bus is reactivated after having been suspended.
- End-of-packet interrupts signify that a low-speed end-of-packet signal was detected.

All USB interrupts share the same interrupt vector. Firmware is responsible for determining which interrupt is active.

9.9.1 USB End-of-Transaction Interrupt

There are five possible end-of-transaction interrupts:

- Endpoint 0 or 2 receive
- Endpoint 0, 1 or 2 transmit

End-of-transaction interrupts occur as detailed in the following sections.

9.9.1.1 Receive Control Endpoint 0

For a control OUT transaction directed at endpoint 0, the USB module will generate an interrupt by setting the RXD0F flag in the UIR0 register. The conditions necessary for the interrupt to occur are shown in the flowchart in **Figure 9-29**.

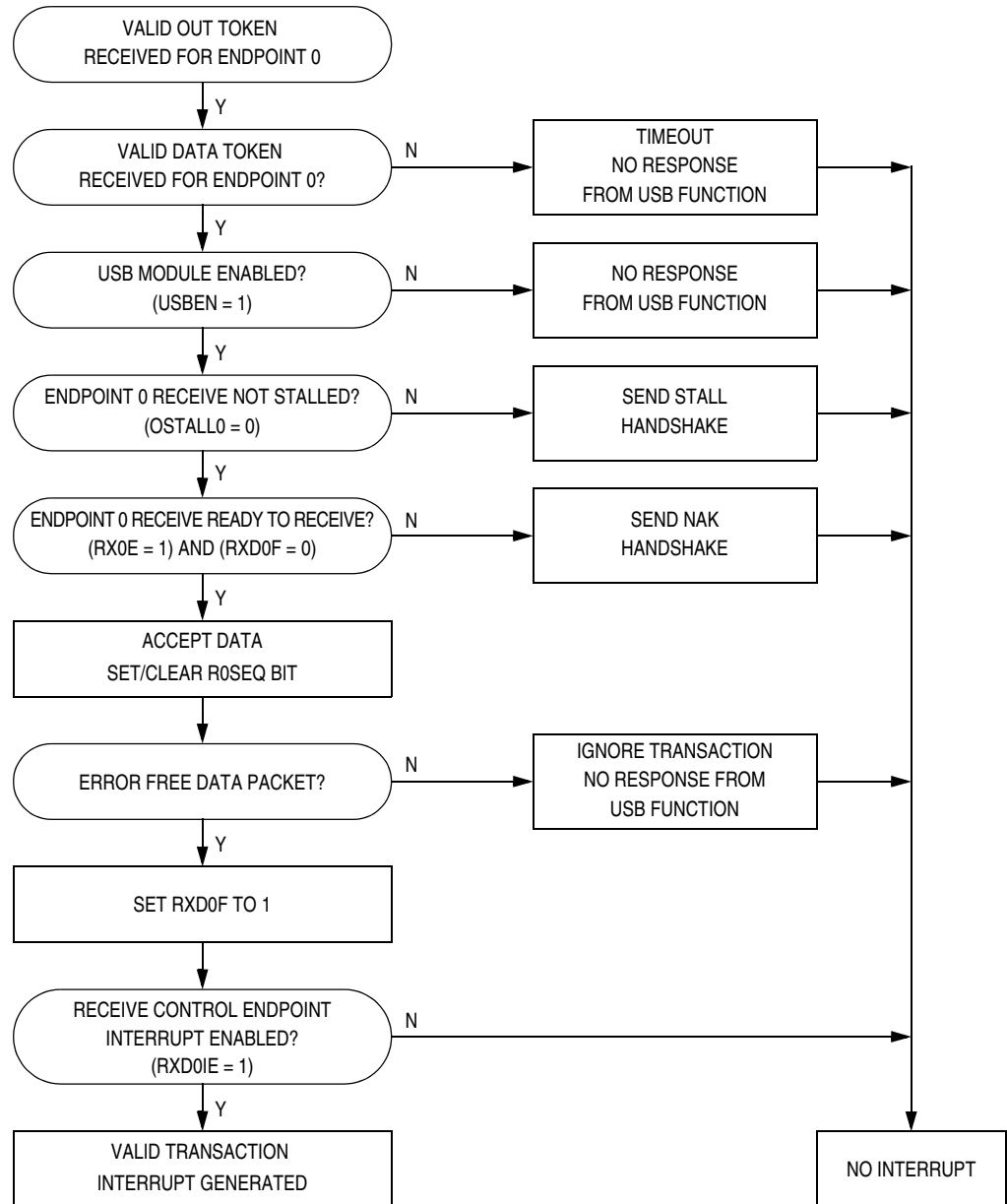

Figure 9-29. OUT Token Data Flow for Receive Endpoint 0

SETUP transactions cannot be stalled by the USB function. A SETUP received by a control endpoint will clear the ISTALL0 and OSTALL0 bits. The conditions for receiving a SETUP interrupt are shown in **Figure 9-30**.

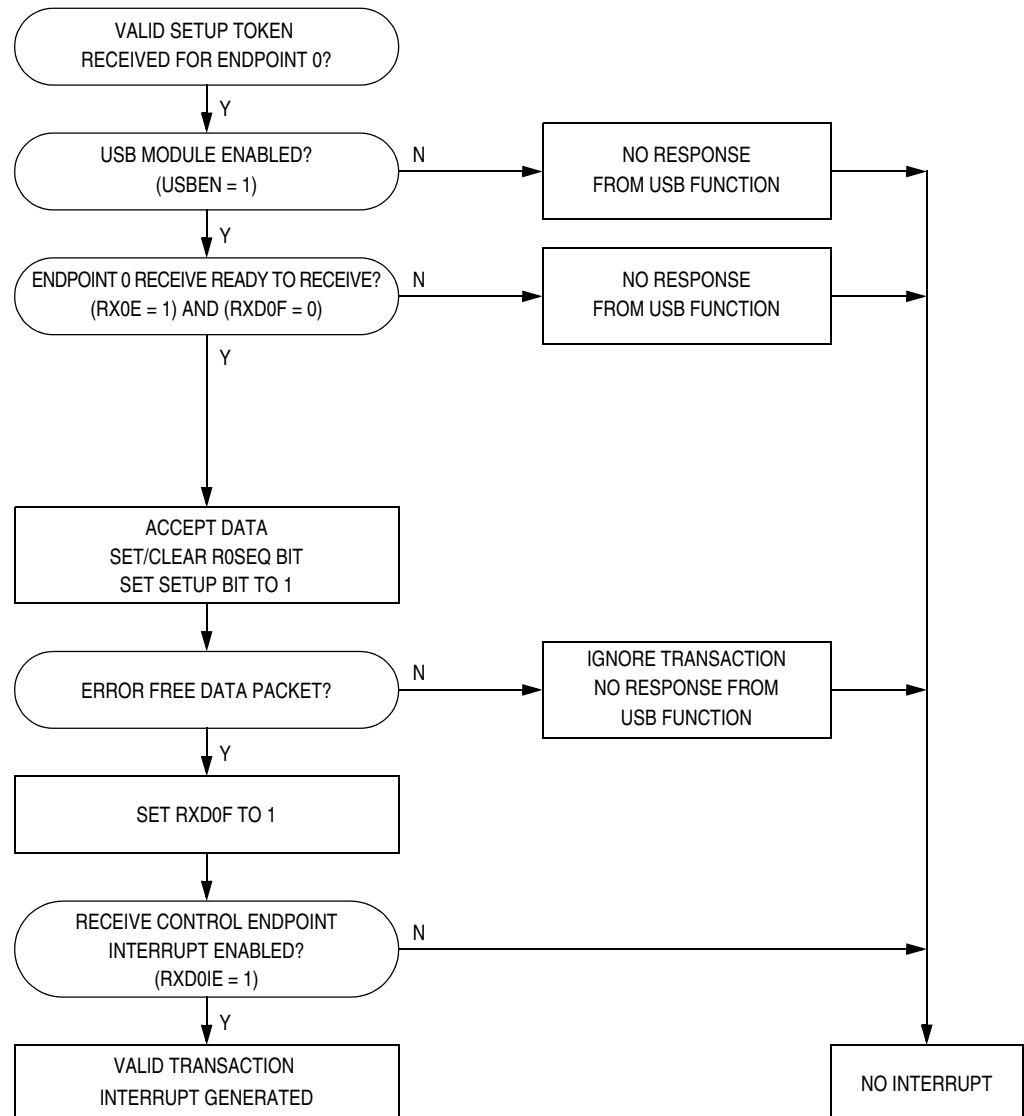

Figure 9-30. SETUP Token Data Flow for Receive Endpoint 0

9.9.1.2 Transmit Control Endpoint 0

For a control IN transaction directed at endpoint 0, the USB module will generate an interrupt by setting the TXD0F flag in the UIR1 register. The conditions necessary for the interrupt to occur are shown in the flowchart in **Figure 9-31**.

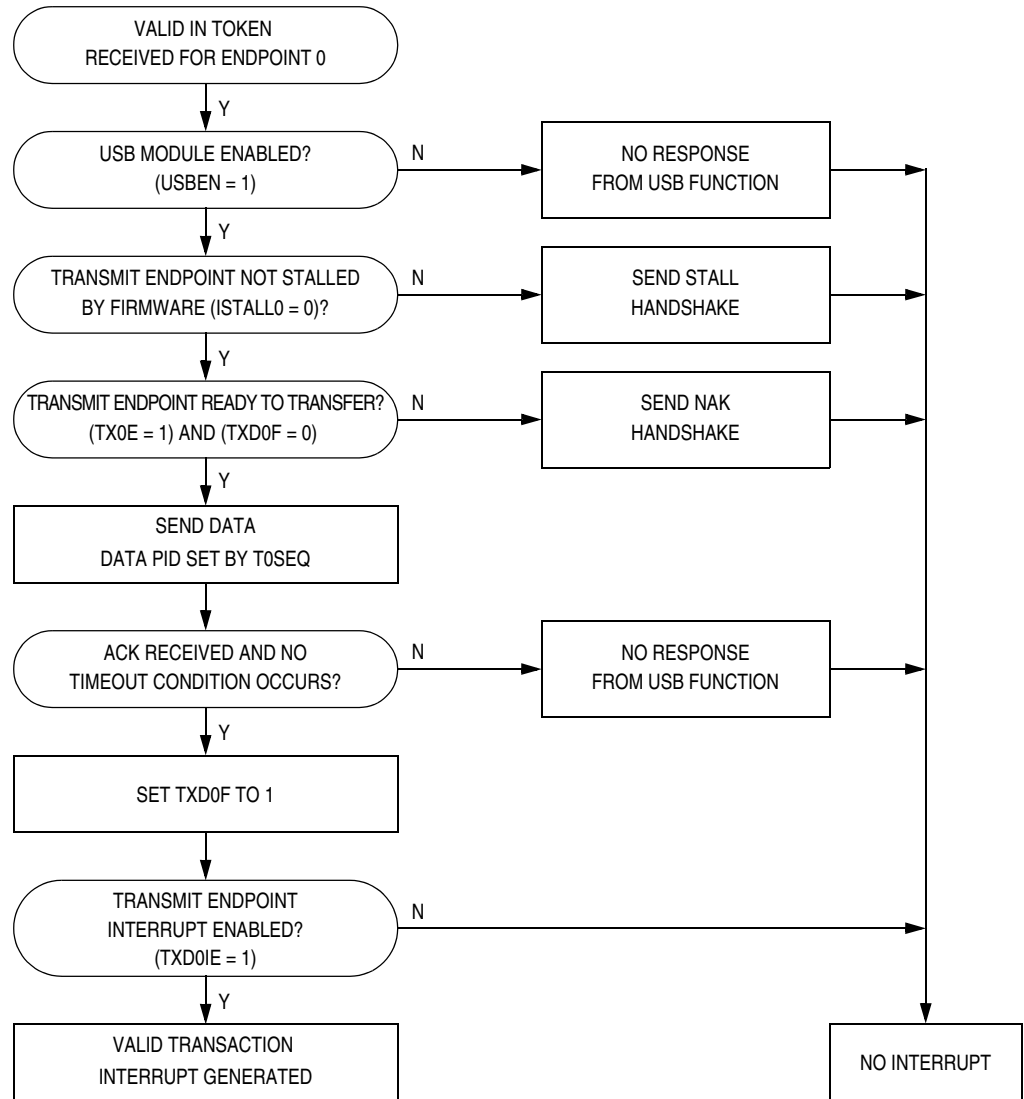

Figure 9-31. IN Token Data Flow for Transmit Endpoint 0

9.9.1.3 Transmit Endpoint 1

For an IN transaction directed at endpoint 1, the USB module will generate an interrupt by setting the TXD1F in the UIR1 register. The conditions necessary for the interrupt to occur are shown in **Figure 9-32**.

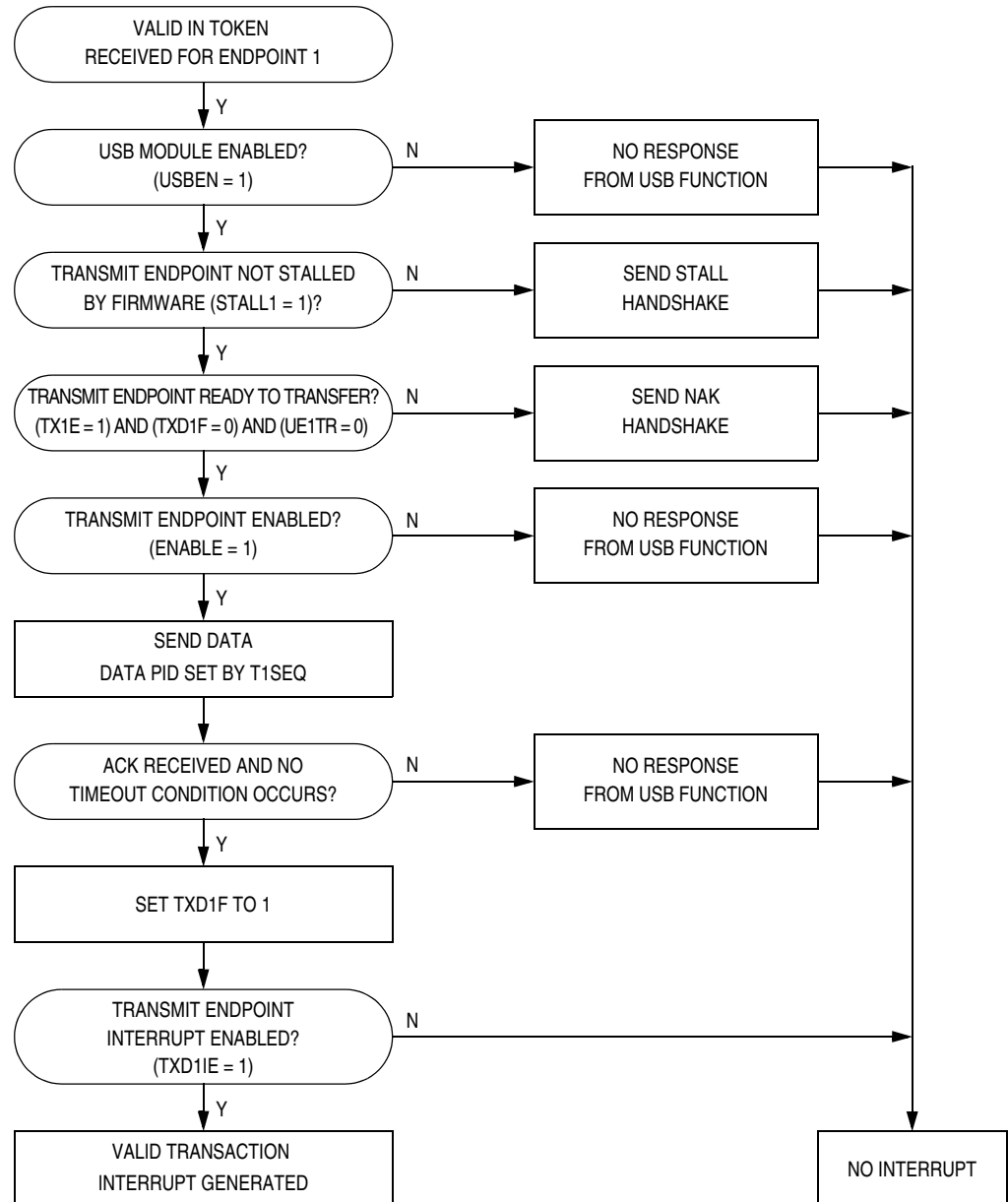

Figure 9-32. IN Token Data Flow for Transmit Endpoint 1

9.9.1.4 Transmit Endpoint 2

For an IN transaction directed at endpoint 2, the USB module will generate an interrupt by setting the TXD2F in the UIR1 register.

9.9.1.5 Receive Endpoint 2

For an OUT transaction directed at endpoint 2, the USB module will generate an interrupt by setting the RXD2F in the UIR1 register.

9.9.2 Resume Interrupt

The USB module will generate a CPU interrupt if low-speed bus activity is detected after entering the suspend state. A transition of the USB data lines to the non-idle state (K state) while in the suspend mode will set the RESUMF flag in the UIR1 register. There is no interrupt enable bit for this interrupt source and an interrupt will be executed if the I-bit in the CCR is cleared. A resume interrupt can only occur while the MCU is in the suspend mode.

9.9.3 End-of-Packet Interrupt

The USB module can generate a USB interrupt upon detection of an end-of-packet signal for low-speed devices. Upon detection of an end-of-packet signal, the USB module sets the EOPF bit and will generate a CPU interrupt if the EOPIE bit in the UIR0 register is set.

Section 10. Monitor ROM (MON)

10.1 Contents

10.2	Introduction	163
10.3	Features	164
10.4	Functional Description	164
10.4.1	Entering Monitor Mode	166
10.4.2	Baud Rate	169
10.4.3	Data Format	170
10.4.4	Echoing	170
10.4.5	Break Signal	171
10.4.6	Commands	171
10.5	Security	175

10.2 Introduction

This section describes the monitor ROM (MON) and the monitor mode entry methods. The monitor ROM allows complete testing of the MCU through a single-wire interface with host computer. This mode is also used for programming and erasing of FLASH memory in the MCU. Monitor mode entry can be achieved without use of the higher voltage, $V_{DD} + V_{HI}$, as long as vector addresses \$FFFE and \$FFFF are blank, thus reducing the hardware requirements for in-circuit programming.

10.3 Features

Features of the monitor ROM include the following:

- Normal user-mode pin functionality
- One pin dedicated to serial communication between monitor ROM and host computer
- Standard mark/space non-return-to-zero (NRZ) communication with host computer
- Execution of code in RAM or FLASH
- FLASH memory security feature¹
- FLASH memory programming interface
- 976 bytes monitor ROM code size
- Monitor mode entry without high voltage, $V_{DD} + V_{HI}$, if reset vector is blank (\$FFFE and \$FFFF contain \$FF)
- Standard monitor mode entry if high voltage, $V_{DD} + V_{HI}$, is applied to \overline{IRQ}

10.4 Functional Description

The monitor ROM receives and executes commands from a host computer. [Figure 10-1](#) shows a example circuit used to enter monitor mode and communicate with a host computer via a standard RS-232 interface.

Simple monitor commands can access any memory address. In monitor mode, the MCU can execute host-computer code in RAM while most MCU pins retain normal operating mode functions. All communication between the host computer and the MCU is through the PTA0 pin. A level-shifting and multiplexing interface is required between PTA0 and the host computer. PTA0 is used in a wired-OR configuration and requires a pull-up resistor.

1. No security feature is absolutely secure. However, Freescale's strategy is to make reading or copying the FLASH difficult for unauthorized users.

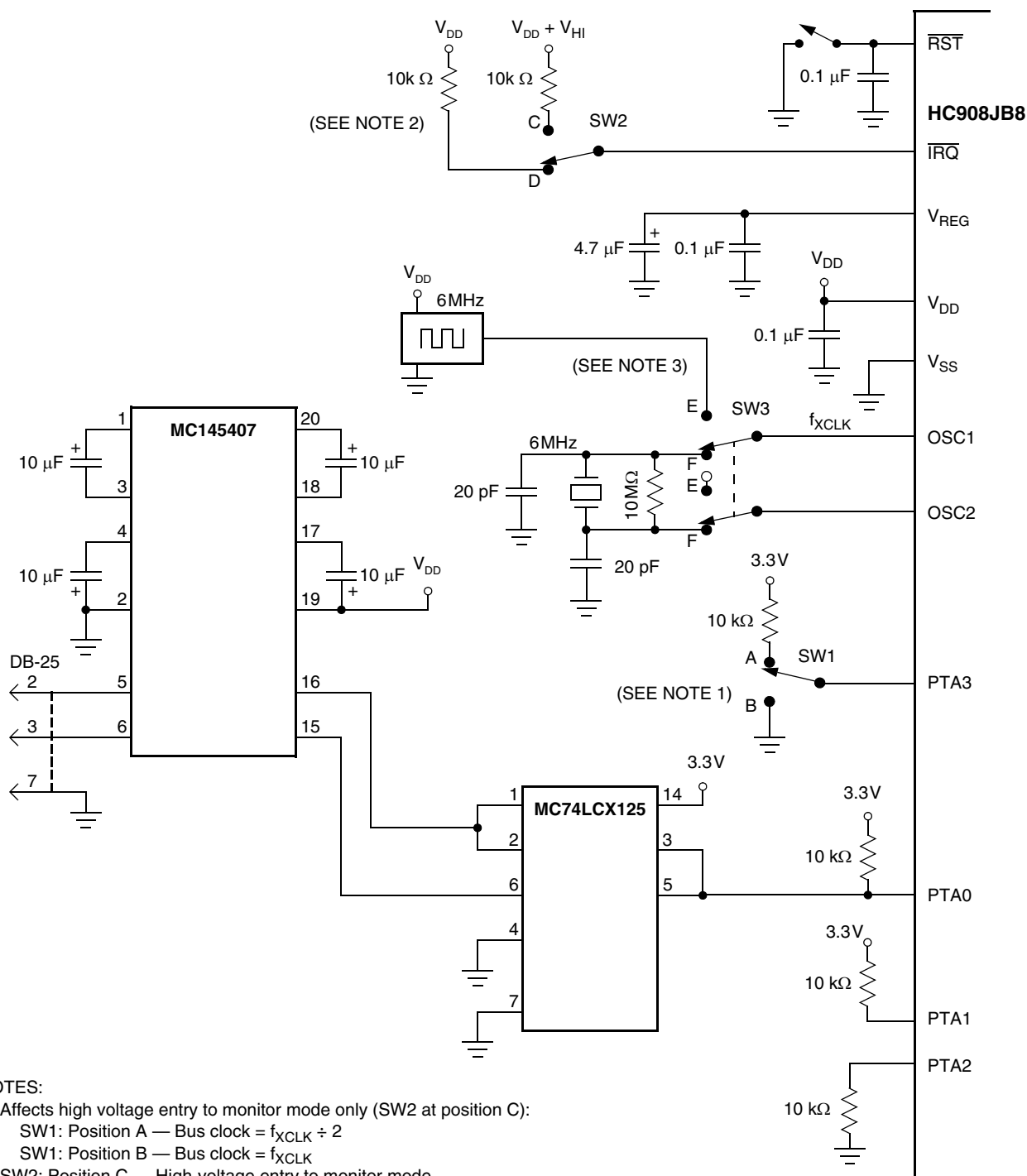

NOTES:

- Affects high voltage entry to monitor mode only (SW2 at position C):
 SW1: Position A — Bus clock = $f_{XCLK} \div 2$
 SW1: Position B — Bus clock = f_{XCLK}
- SW2: Position C — High-voltage entry to monitor mode.
 SW2: Position D — Low-voltage entry to monitor mode (with blank reset vector).
 See [Section 18](#) for IRQ voltage level requirements.
- SW3: Position E — OSC1 directly driven by external oscillator.
 SW3: Position F — OSC1 driven by crystal oscillator circuit.

Figure 10-1. Monitor Mode Circuit

10.4.1 Entering Monitor Mode

Table 10-1 shows the pin conditions for entering monitor mode. As specified in the table, monitor mode may be entered after a POR and will allow communication at 9600 baud provided one of the following sets of conditions is met:

1. If $\overline{\text{IRQ}} = V_{\text{DD}} + V_{\text{HI}}$:
 - External clock on OSC1 is 3MHz
 - PTA3 = low
2. If $\overline{\text{IRQ}} = V_{\text{DD}} + V_{\text{HI}}$:
 - External clock on OSC1 is 6MHz
 - PTA3 = high
3. If \$FFFE & \$FFFF is blank (contains \$FF):
 - External clock on OSC1 is 6MHz
 - $\overline{\text{IRQ}} = V_{\text{DD}}$

Table 10-1. Mode Entry Requirements and Options

$\overline{\text{IRQ}}$	\$FFFE and \$FFFF	PTA3	PTA2	PTA1	PTA0	External Clock, f_{XCLK}	Bus Frequency, f_{BUS}	Comments
$V_{\text{DD}} + V_{\text{HI}}$	X	0	0	1	1	3MHz	3MHz (f_{XCLK})	High-voltage entry to monitor mode.
$V_{\text{DD}} + V_{\text{HI}}$	X	1	0	1	1	6MHz	3MHz ($f_{\text{XCLK}} \div 2$)	9600 baud communication on PTA0. COP disabled.
V_{DD}	BLANK (contain \$FF)	X	X	X	1	6MHz	3MHz ($f_{\text{XCLK}} \div 2$)	Low-voltage entry to monitor mode. 9600 baud communication on PTA0. COP disabled.
V_{DD}	NOT BLANK	X	X	X	X	6MHz	3MHz ($f_{\text{XCLK}} \div 2$)	Enters user mode. If \$FFFE and \$FFFF is blank, MCU will encounter an illegal address reset.
Notes: 1. PTA3 = 0: Bypasses the divide-by-two prescaler to SIM when using $V_{\text{DD}} + V_{\text{HI}}$ for monitor mode entry. 2. See Section 18. Electrical Specifications for $V_{\text{DD}} + V_{\text{HI}}$ voltage level requirements.								

If $V_{DD} + V_{HI}$ is applied to \overline{IRQ} and PTA3 is low upon monitor mode entry (**Table 10-1** condition set 1), the bus frequency is equal to the external clock, f_{XCLK} . If PTA3 is high with $V_{DD} + V_{HI}$ applied to \overline{IRQ} upon monitor mode entry (**Table 10-1** condition set 2), the bus frequency is a divide-by-two of the external clock. Holding the PTA3 pin low when entering monitor mode causes a bypass of a divide-by-two stage at the oscillator *only if $V_{DD} + V_{HI}$ is applied to \overline{IRQ}* . In this event, the OSCOUT frequency is equal to the OSCXCLK frequency.

Entering monitor mode with $V_{DD} + V_{HI}$ on \overline{IRQ} , the COP is disabled as long as $V_{DD} + V_{HI}$ is applied to either the \overline{IRQ} or the \overline{RST} . (See **Section 8. System Integration Module (SIM)** for more information on modes of operation.)

If entering monitor mode without high voltage on \overline{IRQ} and reset vector being blank ($\$FFFE$ and $\$FFFF$) (**Table 10-1** condition set 3, where \overline{IRQ} applied voltage is V_{DD}), then all port A pin requirements and conditions, including the PTA3 frequency divisor selection, are not in effect. This is to reduce circuit requirements when performing in-circuit programming.

Entering monitor mode with the reset vector being blank, the COP is always disabled regardless of the state of \overline{IRQ} or the \overline{RST} .

Figure 10-2. shows a simplified diagram of the monitor mode entry when the reset vector is blank and $\overline{IRQ} = V_{DD}$. An external clock of 6MHz is required for a baud rate of 9600.

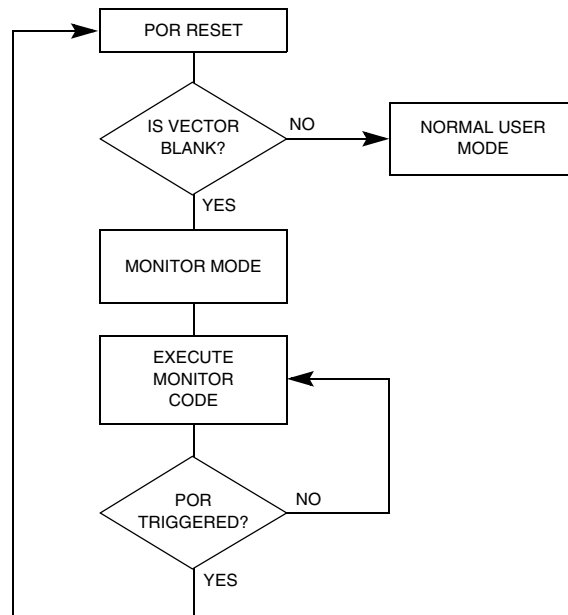

Figure 10-2. Low-Voltage Monitor Mode Entry Flowchart

Enter monitor mode with the pin configuration shown above by pulling \overline{RST} low and then high. The rising edge of \overline{RST} latches monitor mode. Once monitor mode is latched, the values on the specified pins can change.

Once out of reset, the MCU waits for the host to send eight security bytes. (See [10.5 Security](#).) After the security bytes, the MCU sends a break signal (10 consecutive logic zeros) to the host, indicating that it is ready to receive a command. The break signal also provides a timing reference to allow the host to determine the necessary baud rate.

In monitor mode, the MCU uses different vectors for reset, SWI, and break interrupt. The alternate vectors are in the \$FE page instead of the \$FF page and allow code execution from the internal monitor firmware instead of user code.

Table 10-2 is a summary of the vector differences between user mode and monitor mode.

Table 10-2. Monitor Mode Vector Differences

Modes	Functions						
	COP	Reset Vector High	Reset Vector Low	Break Vector High	Break Vector Low	SWI Vector High	SWI Vector Low
User	Enabled	\$FFFE	\$FFFF	\$FFFC	\$FFFD	\$FFFC	\$FFFD
Monitor	Disabled ⁽¹⁾	\$FEFE	\$FEFF	\$FEFC	\$FEFD	\$FEFC	\$FEFD
Notes: 1. If the high voltage ($V_{DD} + V_{HI}$) is removed from the \overline{IRQ} pin or the \overline{RST} pin, the SIM asserts its COP enable output. The COP is a mask option enabled or disabled by the COPD bit in the configuration register.							

When the host computer has completed downloading code into the MCU RAM, the host then sends a RUN command, which executes an RTI, which sends control to the address on the stack pointer.

10.4.2 Baud Rate

The communication baud rate is dependant on oscillator frequency, f_{XCLK} . The state of PTA3 also affects baud rate if entry to monitor mode is by $\overline{IRQ} = V_{DD} + V_{HI}$. When PTA3 is high, the divide by ratio is 625. If the PTA3 pin is at logic zero upon entry into monitor mode, the divide by ratio is 312.

Table 10-3. Monitor Baud Rate Selection

Monitor Mode Entry By:	Oscillator Clock Frequency, f_{CLK}	PTA3	Baud Rate
$\overline{IRQ} = V_{DD} + V_{HI}$	3 MHz	0	9600 bps
	6 MHz	1	9600 bps
	3 MHz	1	4800 bps
Blank reset vector, $\overline{IRQ} = V_{DD}$	6 MHz	X	9600 bps
	3 MHz	X	4800 bps

10.4.3 Data Format

Communication with the monitor ROM is in standard non-return-to-zero (NRZ) mark/space data format. (See [Figure 10-3](#) and [Figure 10-4](#).)

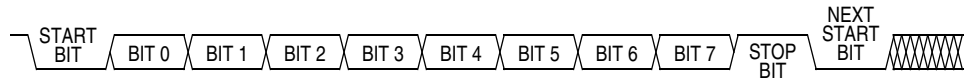

Figure 10-3. Monitor Data Format

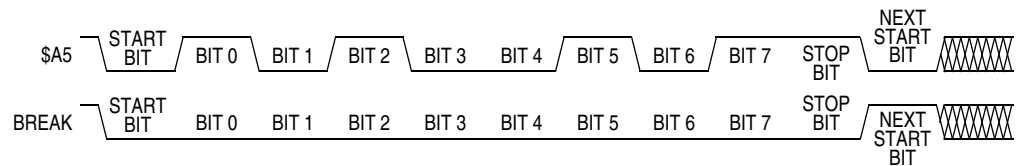

Figure 10-4. Sample Monitor Waveforms

The data transmit and receive rate can be anywhere from 4800 baud to 28.8k-baud. Transmit and receive baud rates must be identical.

10.4.4 Echoing

As shown in [Figure 10-5](#), the monitor ROM immediately echoes each received byte back to the PTA0 pin for error checking.

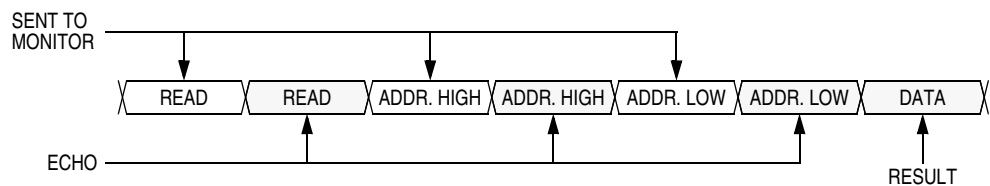

Figure 10-5. Read Transaction

Any result of a command appears after the echo of the last byte of the command.

10.4.5 Break Signal

A start bit followed by nine low bits is a break signal. (See Figure 10-6.) When the monitor receives a break signal, it drives the PTA0 pin high for the duration of two bits before echoing the break signal.

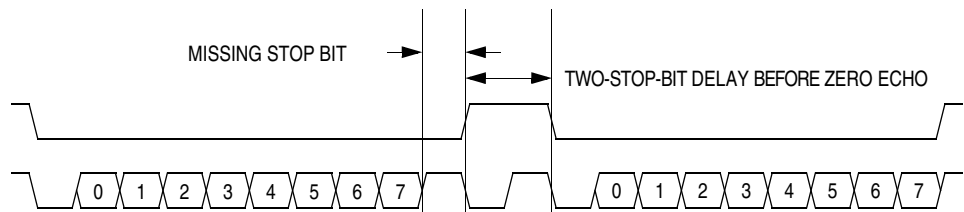

Figure 10-6. Break Transaction

10.4.6 Commands

The monitor ROM uses the following commands:

- READ (read memory)
- WRITE (write memory)
- IREAD (indexed read)
- IWRITE (indexed write)
- READSP (read stack pointer)
- RUN (run user program)

Table 10-4. READ (Read Memory) Command

Description	Read byte from memory
Operand	Specifies 2-byte address in high byte:low byte order
Data Returned	Returns contents of specified address
Opcode	\$4A
<p>Command Sequence</p> <p>SENT TO MONITOR</p> <p>ECHO</p> <p>RESULT</p>	

Table 10-5. WRITE (Write Memory) Command

Description	Write byte to memory
Operand	Specifies 2-byte address in high byte:low byte order; low byte followed by data byte
Data Returned	None
Opcode	\$49
<p>Command Sequence</p> <p>SENT TO MONITOR</p> <p>ECHO</p>	

Table 10-6. IREAD (Indexed Read) Command

Description	Read next 2 bytes in memory from last address accessed
Operand	Specifies 2-byte address in high byte:low byte order
Data Returned	Returns contents of next two addresses
Opcode	\$1A
<p>Command Sequence</p>	

Table 10-7. IWRITE (Indexed Write) Command

Description	Write to last address accessed + 1
Operand	Specifies single data byte
Data Returned	None
Opcode	\$19
<p>Command Sequence</p>	

NOTE: A sequence of IREAD or IWRITE commands can sequentially access a block of memory over the full 64-Kbyte memory map.

Table 10-8. READSP (Read Stack Pointer) Command

Description	Reads stack pointer
Operand	None
Data Returned	Returns stack pointer in high byte:low byte order
Opcode	\$0C
<p>Command Sequence</p>	

Table 10-9. RUN (Run User Program) Command

Description	Executes RTI instruction
Operand	None
Data Returned	None
Opcode	\$28
<p>Command Sequence</p>	

10.5 Security

A security feature discourages unauthorized reading of FLASH locations while in monitor mode. The host can bypass the security feature at monitor mode entry by sending eight security bytes that match the bytes at locations \$FFF6–\$FFFD. Locations \$FFF6–\$FFFD contain user-defined data.

NOTE: Do not leave locations \$FFF6–\$FFFD blank. For security reasons, program locations \$FFF6–\$FFFD even if they are not used for vectors.

During monitor mode entry, the MCU waits after the power-on reset for the host to send the eight security bytes on pin PTA0. If the received bytes match those at locations \$FFF6–\$FFFD, the host bypasses the security feature and can read all FLASH locations and execute code from FLASH. Security remains bypassed until a power-on reset occurs. If the reset was not a power-on reset, security remains bypassed and security code entry is not required. (See [Figure 10-7.](#))

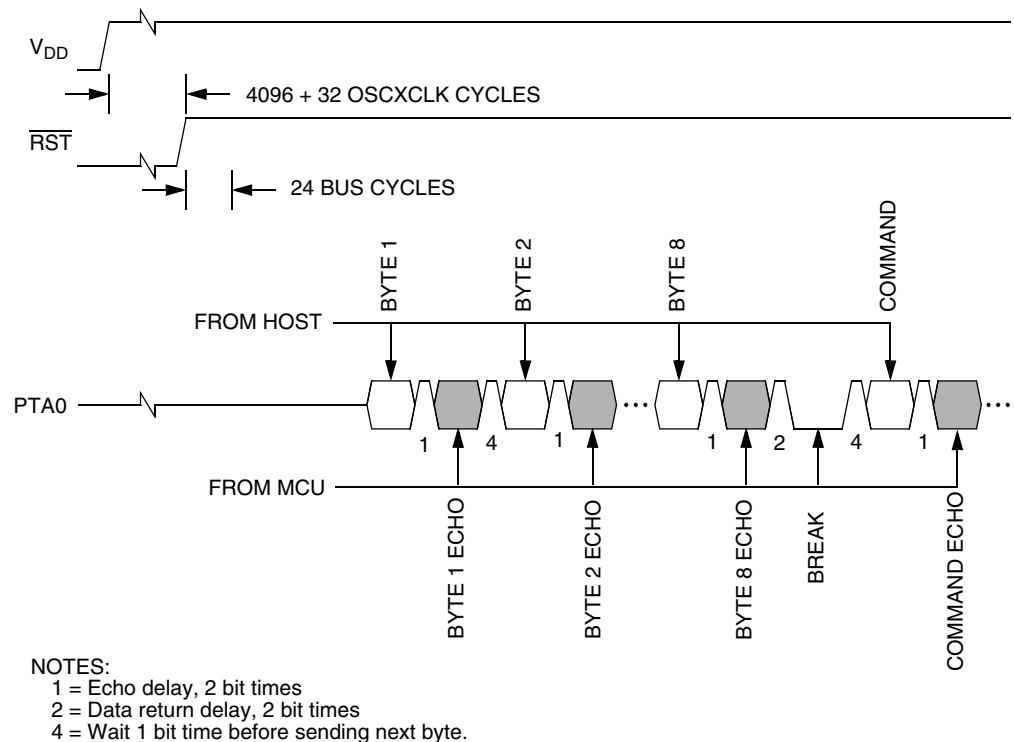

Figure 10-7. Monitor Mode Entry Timing

Upon power-on reset, if the received bytes of the security code do not match the data at locations \$FFF6–\$FFFD, the host fails to bypass the security feature. The MCU remains in monitor mode, but reading a FLASH location returns an invalid value and trying to execute code from FLASH causes an illegal address reset. After receiving the eight security bytes from the host, the MCU transmits a break character, signifying that it is ready to receive a command.

NOTE: *The MCU does not transmit a break character until after the host sends the eight security bytes.*

To determine whether the security code entered is correct, check to see if bit 6 of RAM address \$40 is set. If it is, then the correct security code has been entered and FLASH can be accessed.

If the security sequence fails, the device should be reset by a power-on reset and brought up in monitor mode to attempt another entry. After failing the security sequence, the FLASH module can also be mass erased by executing an erase routine that was downloaded into internal RAM. The mass erase operation clears the security code locations so that all eight security bytes become \$FF (blank).

Section 11. Timer Interface Module (TIM)

11.1 Contents

11.2	Introduction	178
11.3	Features	178
11.4	Pin Name Conventions	178
11.5	Functional Description	179
11.5.1	TIM Counter Prescaler	181
11.5.2	Input Capture	181
11.5.3	Output Compare	181
11.5.3.1	Unbuffered Output Compare	182
11.5.3.2	Buffered Output Compare	183
11.5.4	Pulse Width Modulation (PWM)	183
11.5.4.1	Unbuffered PWM Signal Generation	184
11.5.4.2	Buffered PWM Signal Generation	185
11.5.4.3	PWM Initialization	186
11.6	Interrupts	187
11.7	Low-Power Modes	187
11.7.1	Wait Mode	188
11.7.2	Stop Mode	188
11.8	TIM During Break Interrupts	188
11.9	I/O Signals	189
11.9.1	TIM Clock Pin (PTE0/TCLK)	189
11.9.2	TIM Channel I/O Pins (PTE1/TCH0:PTE2/TCH1)	189
11.10	I/O Registers	189
11.10.1	TIM Status and Control Register	190
11.10.2	TIM Counter Registers	192
11.10.3	TIM Counter Modulo Registers	193
11.10.4	TIM Channel Status and Control Registers	194
11.10.5	TIM Channel Registers	198

11.2 Introduction

This section describes the timer interface module (TIM2, Version B). The TIM is a 2-channel timer that provides a timing reference with input capture, output compare, and pulse-width-modulation functions.

[Figure 11-1](#) is a block diagram of the TIM.

11.3 Features

Features of the TIM include:

- Two input capture/output compare channels
 - Rising-edge, falling-edge, or any-edge input capture trigger
 - Set, clear, or toggle output compare action
- Buffered and unbuffered pulse width modulation (PWM) signal generation
- Programmable TIM clock input
 - 7-frequency internal bus clock prescaler selection
 - External TIM clock input (bus frequency $\div 2$ maximum)
- Free-running or modulo up-count operation
- Toggle any channel pin on overflow
- TIM counter stop and reset bits

11.4 Pin Name Conventions

The TIM share three I/O pins with three port E I/O pins. The full name of the TIM I/O pin is listed in [Table 11-1](#). The generic pin name appear in the text that follows.

Table 11-1. TIM Pin Name Conventions

TIM Generic Pin Names:	TCLK	TCH0	TCH1
Full TIM Pin Names:	PTE0/TCLK	PTE1/TCH0	PTE2/TCH1

11.5 Functional Description

Figure 11-1 shows the structure of the TIM. The central component of the TIM is the 16-bit TIM counter that can operate as a free-running counter or a modulo up-counter. The TIM counter provides the timing reference for the input capture and output compare functions. The TIM counter modulo registers, TMODH:TMODL, control the modulo value of the TIM counter. Software can read the TIM counter value at any time without affecting the counting sequence.

The two TIM channels are programmable independently as input capture or output compare channels.

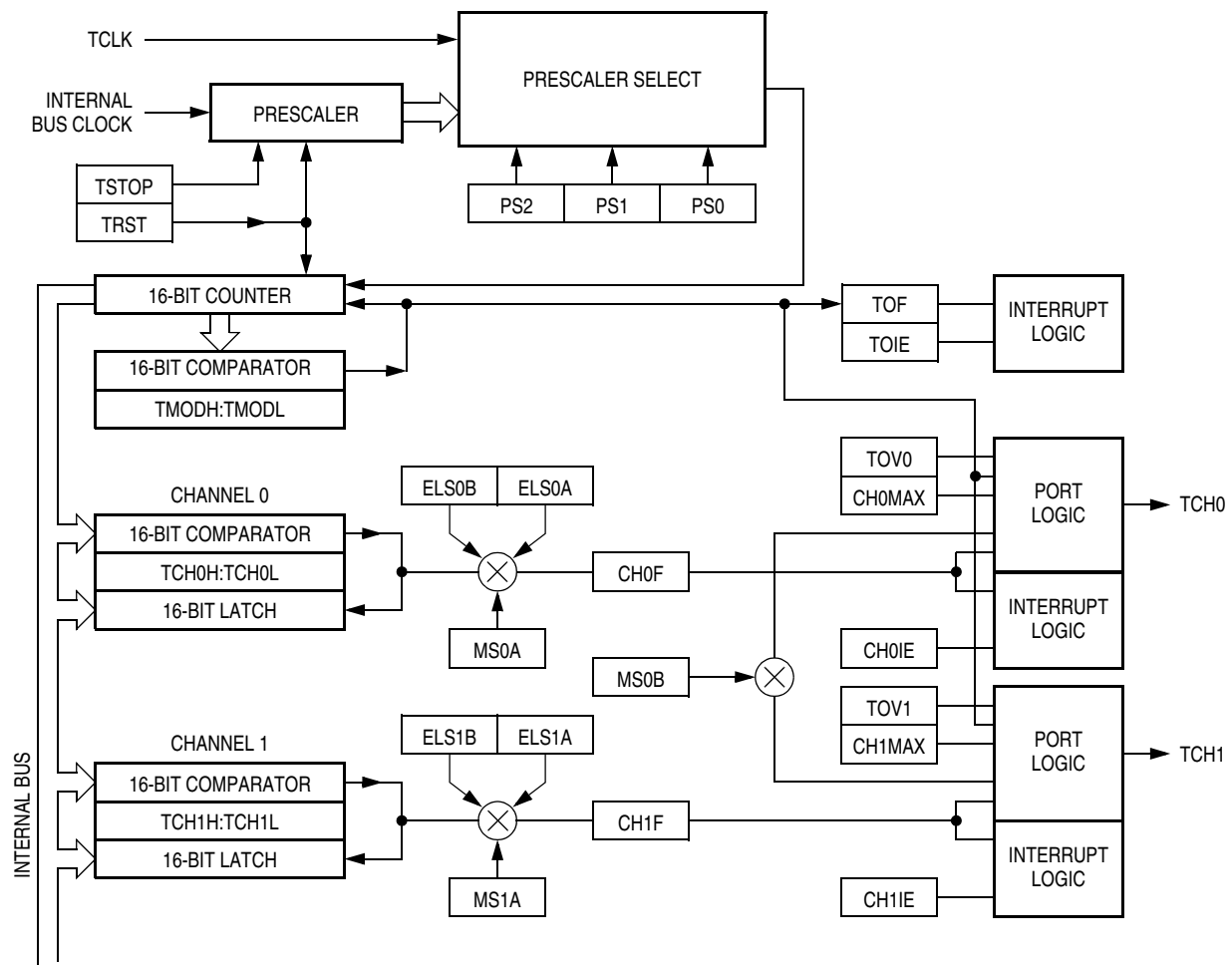

Figure 11-1. TIM Block Diagram

Timer Interface Module (TIM)

Addr.	Register Name	Bit 7	6	5	4	3	2	1	Bit 0	
\$000A	TIM Status and Control Register (TSC)	Read:	TOF	TOIE	TSTOP	0	0	PS2	PS1	PS0
		Write:	0			TRST				
		Reset:	0	0	1	0	0	0	0	0
\$000C	TIM Counter Register High (TCNTH)	Read:	Bit15	Bit14	Bit13	Bit12	Bit11	Bit10	Bit9	Bit8
		Write:								
		Reset:	0	0	0	0	0	0	0	0
\$000D	TIM Counter Register Low (TCNTL)	Read:	Bit7	Bit6	Bit5	Bit4	Bit3	Bit2	Bit1	Bit0
		Write:								
		Reset:	0	0	0	0	0	0	0	0
\$000E	TIM Counter Modulo Register High (TMODH)	Read:	Bit15	Bit14	Bit13	Bit12	Bit11	Bit10	Bit9	Bit8
		Write:								
		Reset:	1	1	1	1	1	1	1	1
\$000F	TIM Counter Modulo Register Low (TMODL)	Read:	Bit7	Bit6	Bit5	Bit4	Bit3	Bit2	Bit1	Bit0
		Write:								
		Reset:	1	1	1	1	1	1	1	1
\$0010	TIM Channel 0 Status and Control Register (TSC0)	Read:	CH0F	CH0IE	MS0B	MS0A	ELS0B	ELS0A	TOV0	CH0MAX
		Write:	0							
		Reset:	0	0	0	0	0	0	0	0
\$0011	TIM Channel 0 Register High (TCH0H)	Read:	Bit15	Bit14	Bit13	Bit12	Bit11	Bit10	Bit9	Bit8
		Write:								
		Reset:	Indeterminate after reset							
\$0012	TIM Channel 0 Register Low (TCH0L)	Read:	Bit7	Bit6	Bit5	Bit4	Bit3	Bit2	Bit1	Bit0
		Write:								
		Reset:	Indeterminate after reset							
\$0013	TIM Channel 1 Status and Control Register (TSC1)	Read:	CH1F	CH1IE	0	MS1A	ELS1B	ELS1A	TOV1	CH1MAX
		Write:	0							
		Reset:	0	0	0	0	0	0	0	0

= Unimplemented

Figure 11-2. TIM I/O Register Summary

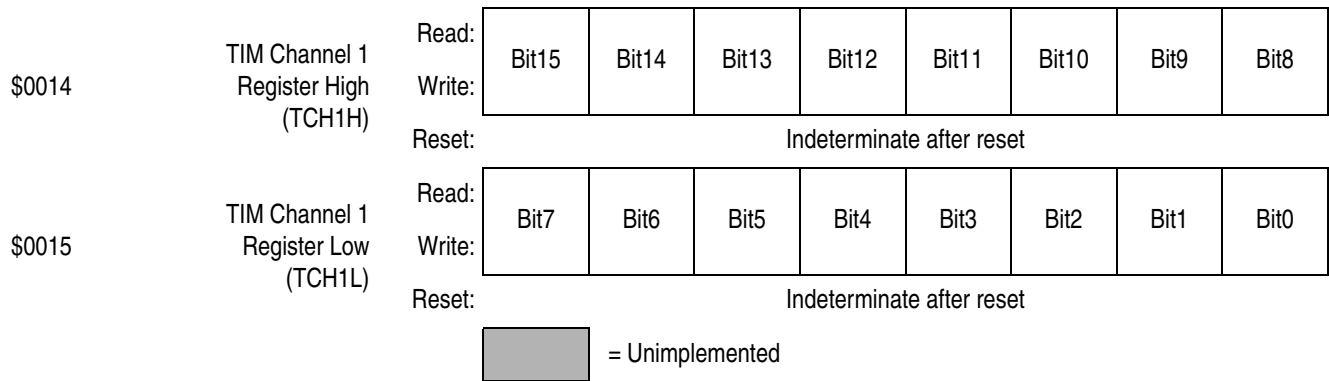

Figure 11-2. TIM I/O Register Summary

11.5.1 TIM Counter Prescaler

The TIM clock source can be one of the seven prescaler outputs or the TIM clock pin, PTE0/TCLK. The prescaler generates seven clock rates from the internal bus clock. The prescaler select bits, PS[2:0], in the TIM status and control register (TSC) select the TIM clock source.

11.5.2 Input Capture

With the input capture function, the TIM can capture the time at which an external event occurs. When an active edge occurs on the pin of an input capture channel, the TIM latches the contents of the TIM counter into the TIM channel registers, TCHxH:TCHxL. The polarity of the active edge is programmable. Input captures can generate TIM CPU interrupt requests.

11.5.3 Output Compare

With the output compare function, the TIM can generate a periodic pulse with a programmable polarity, duration, and frequency. When the counter reaches the value in the registers of an output compare channel, the TIM can set, clear, or toggle the channel pin. Output compares can generate TIM CPU interrupt requests.

11.5.3.1 Unbuffered Output Compare

Any output compare channel can generate unbuffered output compare pulses as described in [11.5.3 Output Compare](#). The pulses are unbuffered because changing the output compare value requires writing the new value over the old value currently in the TIM channel registers.

An unsynchronized write to the TIM channel registers to change an output compare value could cause incorrect operation for up to two counter overflow periods. For example, writing a new value before the counter reaches the old value but after the counter reaches the new value prevents any compare during that counter overflow period. Also, using a TIM overflow interrupt routine to write a new, smaller output compare value may cause the compare to be missed. The TIM may pass the new value before it is written.

Use the following methods to synchronize unbuffered changes in the output compare value on channel x:

- When changing to a smaller value, enable channel x output compare interrupts and write the new value in the output compare interrupt routine. The output compare interrupt occurs at the end of the current output compare pulse. The interrupt routine has until the end of the counter overflow period to write the new value.
- When changing to a larger output compare value, enable TIM overflow interrupts and write the new value in the TIM overflow interrupt routine. The TIM overflow interrupt occurs at the end of the current counter overflow period. Writing a larger value in an output compare interrupt routine (at the end of the current pulse) could cause two output compares to occur in the same counter overflow period.

11.5.3.2 Buffered Output Compare

Channels 0 and 1 can be linked to form a buffered output compare channel whose output appears on the PTE1/TCH0 pin. The TIM channel registers of the linked pair alternately control the output.

Setting the MS0B bit in TIM channel 0 status and control register (TSC0) links channel 0 and channel 1. The output compare value in the TIM channel 0 registers initially controls the output on the PTE1/TCH0 pin. Writing to the TIM channel 1 registers enables the TIM channel 1 registers to synchronously control the output after the TIM overflows. At each subsequent overflow, the TIM channel registers (0 or 1) that control the output are the ones written to last. TSC0 controls and monitors the buffered output compare function, and TIM channel 1 status and control register (TSC1) is unused. While the MS0B bit is set, the channel 1 pin, PTE2/TCH1, is available as a general-purpose I/O pin.

NOTE: *In buffered output compare operation, do not write new output compare values to the currently active channel registers. User software should track the currently active channel to prevent writing a new value to the active channel. Writing to the active channel registers is the same as generating unbuffered output compares.*

11.5.4 Pulse Width Modulation (PWM)

By using the toggle-on-overflow feature with an output compare channel, the TIM can generate a PWM signal. The value in the TIM counter modulo registers determines the period of the PWM signal. The channel pin toggles when the counter reaches the value in the TIM counter modulo registers. The time between overflows is the period of the PWM signal.

As [Figure 11-3](#) shows, the output compare value in the TIM channel registers determines the pulse width of the PWM signal. The time between overflow and output compare is the pulse width. Program the TIM to clear the channel pin on output compare if the state of the PWM pulse is logic 1. Program the TIM to set the pin if the state of the PWM pulse is logic 0.

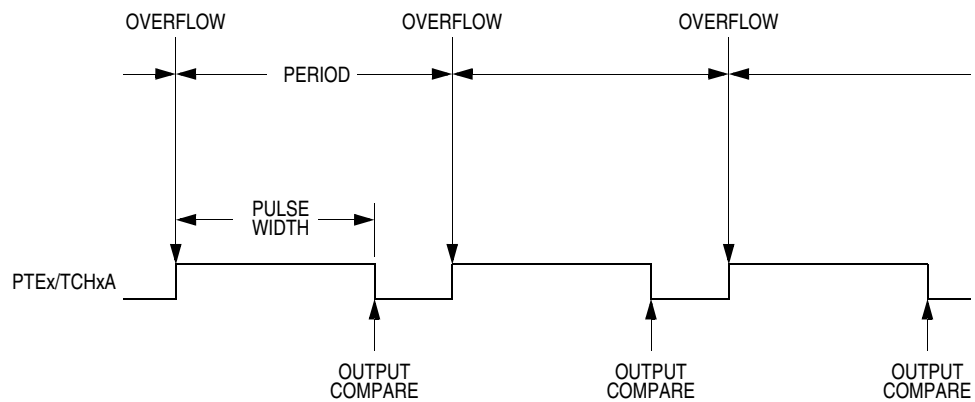

Figure 11-3. PWM Period and Pulse Width

The value in the TIM counter modulo registers and the selected prescaler output determines the frequency of the PWM output. The frequency of an 8-bit PWM signal is variable in 256 increments. Writing \$00FF (255) to the TIM counter modulo registers produces a PWM period of 256 times the internal bus clock period if the prescaler select value is 000 (see [11.10.1 TIM Status and Control Register](#)).

The value in the TIM channel registers determines the pulse width of the PWM output. The pulse width of an 8-bit PWM signal is variable in 256 increments. Writing \$0080 (128) to the TIM channel registers produces a duty cycle of 128/256 or 50%.

11.5.4.1 Unbuffered PWM Signal Generation

Any output compare channel can generate unbuffered PWM pulses as described in [11.5.4 Pulse Width Modulation \(PWM\)](#). The pulses are unbuffered because changing the pulse width requires writing the new pulse width value over the old value currently in the TIM channel registers.

An unsynchronized write to the TIM channel registers to change a pulse width value could cause incorrect operation for up to two PWM periods. For example, writing a new value before the counter reaches the old value but after the counter reaches the new value prevents any compare during that PWM period. Also, using a TIM overflow interrupt routine to write a new, smaller pulse width value may cause the compare to be missed. The TIM may pass the new value before it is written.

Use the following methods to synchronize unbuffered changes in the PWM pulse width on channel x:

- When changing to a shorter pulse width, enable channel x output compare interrupts and write the new value in the output compare interrupt routine. The output compare interrupt occurs at the end of the current pulse. The interrupt routine has until the end of the PWM period to write the new value.
- When changing to a longer pulse width, enable TIM overflow interrupts and write the new value in the TIM overflow interrupt routine. The TIM overflow interrupt occurs at the end of the current PWM period. Writing a larger value in an output compare interrupt routine (at the end of the current pulse) could cause two output compares to occur in the same PWM period.

NOTE: *In PWM signal generation, do not program the PWM channel to toggle on output compare. Toggling on output compare prevents reliable 0% duty cycle generation and removes the ability of the channel to self-correct in the event of software error or noise. Toggling on output compare also can cause incorrect PWM signal generation when changing the PWM pulse width to a new, much larger value.*

11.5.4.2 Buffered PWM Signal Generation

Channels 0 and 1 can be linked to form a buffered PWM channel whose output appears on the PTE1/TCH0 pin. The TIM channel registers of the linked pair alternately control the pulse width of the output.

Setting the MS0B bit in TIM channel 0 status and control register (TSC0) links channel 0 and channel 1. The TIM channel 0 registers initially control the pulse width on the PTE1/TCH0 pin. Writing to the TIM channel 1 registers enables the TIM channel 1 registers to synchronously control the pulse width at the beginning of the next PWM period. At each subsequent overflow, the TIM channel registers (0 or 1) that control the pulse width are the ones written to last. TSC0 controls and monitors the buffered PWM function, and TIM channel 1 status and control register (TSC1) is unused. While the MS0B bit is set, the channel 1 pin, PTE2/TCH1, is available as a general-purpose I/O pin.

NOTE: *In buffered PWM signal generation, do not write new pulse width values to the currently active channel registers. User software should track the currently active channel to prevent writing a new value to the active channel. Writing to the active channel registers is the same as generating unbuffered PWM signals.*

11.5.4.3 PWM Initialization

To ensure correct operation when generating unbuffered or buffered PWM signals, use this initialization procedure:

1. In the TIM status and control register (TSC):
 - a. Stop the TIM counter by setting the TIM stop bit, TSTOP.
 - b. Reset the TIM counter and prescaler by setting the TIM reset bit, TRST.
2. In the TIM counter modulo registers (TMODH:TMODL), write the value for the required PWM period.
3. In the TIM channel x registers (TCHxH:TCHxL), write the value for the required pulse width.
4. In TIM channel x status and control register (TSCx):
 - a. Write 0:1 (for unbuffered output compare or PWM signals) or 1:0 (for buffered output compare or PWM signals) to the mode select bits, MSxB:MSxA. (See [Table 11-3](#).)
 - b. Write 1 to the toggle-on-overflow bit, TOVx.
 - c. Write 1:0 (to clear output on compare) or 1:1 (to set output on compare) to the edge/level select bits, ELSxB:ELSxA. The output action on compare must force the output to the complement of the pulse width level. (See [Table 11-3](#).)

NOTE: *In PWM signal generation, do not program the PWM channel to toggle on output compare. Toggling on output compare prevents reliable 0% duty cycle generation and removes the ability of the channel to self-correct in the event of software error or noise. Toggling on output compare can also cause incorrect PWM signal generation when changing the PWM pulse width to a new, much larger value.*

5. In the TIM status control register (TSC), clear the TIM stop bit, TSTOP.

Setting MS0B links channels 0 and 1 and configures them for buffered PWM operation. The TIM channel 0 registers (TCH0H:TCH0L) initially control the buffered PWM output. TIM status control register 0 (TSCR0) controls and monitors the PWM signal from the linked channels. MS0B takes priority over MS0A.

Clearing the toggle-on-overflow bit, TOVx, inhibits output toggles on TIM overflows. Subsequent output compares try to force the output to a state it is already in and have no effect. The result is a 0% duty cycle output.

Setting the channel x maximum duty cycle bit (CHxMAX) and setting the TOVx bit generates a 100% duty cycle output. (See [11.10.4 TIM Channel Status and Control Registers](#).)

11.6 Interrupts

The following TIM sources can generate interrupt requests:

- TIM overflow flag (TOF) — The TOF bit is set when the TIM counter reaches the modulo value programmed in the TIM counter modulo registers. The TIM overflow interrupt enable bit, TOIE, enables TIM overflow CPU interrupt requests. TOF and TOIE are in the TIM status and control register.
- TIM channel flags (CH1F:CH0F) — The CHxF bit is set when an input capture or output compare occurs on channel x. Channel x TIM CPU interrupt requests are controlled by the channel x interrupt enable bit, CHxIE. Channel x TIM CPU interrupt requests are enabled when CHxIE = 1. CHxF and CHxIE are in the TIM channel x status and control register.

11.7 Low-Power Modes

The WAIT and STOP instructions put the MCU in low power-consumption standby modes.

11.7.1 Wait Mode

The TIM remains active after the execution of a WAIT instruction. In wait mode the TIM registers are not accessible by the CPU. Any enabled CPU interrupt request from the TIM can bring the MCU out of wait mode.

If TIM functions are not required during wait mode, reduce power consumption by stopping the TIM before executing the WAIT instruction.

11.7.2 Stop Mode

The TIM is inactive after the execution of a STOP instruction. The STOP instruction does not affect register conditions or the state of the TIM counter. TIM operation resumes when the MCU exits stop mode after an external interrupt.

11.8 TIM During Break Interrupts

A break interrupt stops the TIM counter.

The system integration module (SIM) controls whether status bits in other modules can be cleared during the break state. The BCFE bit in the break flag control register (BFCR) enables software to clear status bits during the break state. (See [8.8.3 Break Flag Control Register](#).)

To allow software to clear status bits during a break interrupt, write a logic 1 to the BCFE bit. If a status bit is cleared during the break state, it remains cleared when the MCU exits the break state.

To protect status bits during the break state, write a logic 0 to the BCFE bit. With BCFE at logic 0 (its default state), software can read and write I/O registers during the break state without affecting status bits. Some status bits have a 2-step read/write clearing procedure. If software does the first step on such a bit before the break, the bit cannot change during the break state as long as BCFE is at logic 0. After the break, doing the second step clears the status bit.

11.9 I/O Signals

Port E shares three of its pins with the TIM. PTE0/TCLK is an external clock input to the TIM prescaler. The two TIM channel I/O pins are PTE1/TCH0 and PTE2/TCH1.

11.9.1 TIM Clock Pin (PTE0/TCLK)

PTE0/TCLK is an external clock input that can be the clock source for the TIM counter instead of the prescaled internal bus clock. Select the PTE0/TCLK input by writing logic 1s to the three prescaler select bits, PS[2:0]. (See [11.10.1 TIM Status and Control Register](#).) The minimum TCLK pulse width, $TCLK_{L\text{MIN}}$ or $TCLK_{H\text{MIN}}$, is:

$$\frac{1}{\text{bus frequency}} + t_{\text{SU}}$$

The maximum TCLK frequency is:

$$\text{bus frequency} \div 2$$

PTE0/TCLK is available as a general-purpose I/O pin when not used as the TIM clock input. When the PTE0/TCLK pin is the TIM clock input, it is an input regardless of the state of the DDRE0 bit in data direction register E.

11.9.2 TIM Channel I/O Pins (PTE1/TCH0:PTE2/TCH1)

Each channel I/O pin is programmable independently as an input capture pin or an output compare pin. PTE1/TCH0 can be configured as buffered output compare or buffered PWM pins.

11.10 I/O Registers

The following I/O registers control and monitor operation of the TIM:

- TIM status and control register (TSC)
- TIM counter registers (TCNTH:TCNTL)
- TIM counter modulo registers (TMODH:TMODL)
- TIM channel status and control registers (TSC0 and TSC1)
- TIM channel registers (TCH0H:TCH0L and TCH1H:TCH1L)

11.10.1 TIM Status and Control Register

The TIM status and control register:

- Enables TIM overflow interrupts
- Flags TIM overflows
- Stops the TIM counter
- Resets the TIM counter
- Prescales the TIM counter clock

Address: \$000A

	Bit 7	6	5	4	3	2	1	Bit 0
Read:	TOF	TOIE	TSTOP	0	0	PS2	PS1	PS0
Write:	0			TRST				
Reset:	0	0	1	0	0	0	0	0

 = Unimplemented

Figure 11-4. TIM Status and Control Register (TSC)

TOF — TIM Overflow Flag Bit

This read/write flag is set when the TIM counter reaches the modulo value programmed in the TIM counter modulo registers. Clear TOF by reading the TIM status and control register when TOF is set and then writing a logic 0 to TOF. If another TIM overflow occurs before the clearing sequence is complete, then writing logic 0 to TOF has no effect. Therefore, a TOF interrupt request cannot be lost due to inadvertent clearing of TOF. Reset clears the TOF bit. Writing a logic 1 to TOF has no effect.

1 = TIM counter has reached modulo value

0 = TIM counter has not reached modulo value

TOIE — TIM Overflow Interrupt Enable Bit

This read/write bit enables TIM overflow interrupts when the TOF bit becomes set. Reset clears the TOIE bit.

1 = TIM overflow interrupts enabled

0 = TIM overflow interrupts disabled

TSTOP — TIM Stop Bit

This read/write bit stops the TIM counter. Counting resumes when TSTOP is cleared. Reset sets the TSTOP bit, stopping the TIM counter until software clears the TSTOP bit.

- 1 = TIM counter stopped
- 0 = TIM counter active

NOTE: Do not set the TSTOP bit before entering wait mode if the TIM is required to exit wait mode.

TRST — TIM Reset Bit

Setting this write-only bit resets the TIM counter and the TIM prescaler. Setting TRST has no effect on any other registers. Counting resumes from \$0000. TRST is cleared automatically after the TIM counter is reset and always reads as logic 0. Reset clears the TRST bit.

- 1 = Prescaler and TIM counter cleared
- 0 = No effect

NOTE: Setting the TSTOP and TRST bits simultaneously stops the TIM counter at a value of \$0000.

PS[2:0] — Prescaler Select Bits

These read/write bits select either the PTE0/TCLK pin or one of the seven prescaler outputs as the input to the TIM counter as [Table 11-2](#) shows. Reset clears the PS[2:0] bits.

Table 11-2. Prescaler Selection

PS2	PS1	PS0	TIM Clock Source
0	0	0	Internal Bus Clock ÷ 1
0	0	1	Internal Bus Clock ÷ 2
0	1	0	Internal Bus Clock ÷ 4
0	1	1	Internal Bus Clock ÷ 8
1	0	0	Internal Bus Clock ÷ 16
1	0	1	Internal Bus Clock ÷ 32
1	1	0	Internal Bus Clock ÷ 64
1	1	1	PTE0/TCLK

11.10.2 TIM Counter Registers

The two read-only TIM counter registers contain the high and low bytes of the value in the TIM counter. Reading the high byte (TCNTH) latches the contents of the low byte (TCNTL) into a buffer. Subsequent reads of TCNTH do not affect the latched TCNTL value until TCNTL is read. Reset clears the TIM counter registers. Setting the TIM reset bit (TRST) also clears the TIM counter registers.

NOTE: *If you read TCNTH during a break interrupt, be sure to unlatch TCNTL by reading TCNTL before exiting the break interrupt. Otherwise, TCNTL retains the value latched during the break.*

TCNTH Address: \$000C

	Bit 7	6	5	4	3	2	1	Bit 0
Read:	Bit 15	Bit 14	Bit 13	Bit 12	Bit 11	Bit 10	Bit 9	Bit 8
Write:								
Reset:	0	0	0	0	0	0	0	0

TCNTL Address: \$000D

	Bit 7	6	5	4	3	2	1	Bit 0
Read:	Bit 7	Bit 6	Bit 5	Bit 4	Bit 3	Bit 2	Bit 1	Bit 0
Write:								
Reset:	0	0	0	0	0	0	0	0

 = Unimplemented

Figure 11-5. TIM Counter Registers (TCNTH:TCNTL)

11.10.3 TIM Counter Modulo Registers

The read/write TIM modulo registers contain the modulo value for the TIM counter. When the TIM counter reaches the modulo value, the overflow flag (TOF) becomes set, and the TIM counter resumes counting from \$0000 at the next timer clock. Writing to the high byte (TMODH) inhibits the TOF bit and overflow interrupts until the low byte (TMODL) is written. Reset sets the TIM counter modulo registers.

TMODH Address: \$000E

	Bit 7	6	5	4	3	2	1	Bit 0
Read:	Bit 15	Bit 14	Bit 13	Bit 12	Bit 11	Bit 10	Bit 9	Bit 8
Write:								
Reset:	1	1	1	1	1	1	1	1

TMODL Address: \$000F

	Bit 7	6	5	4	3	2	1	Bit 0
Read:	Bit 7	Bit 6	Bit 5	Bit 4	Bit 3	Bit 2	Bit 1	Bit 0
Write:								
Reset:	1	1	1	1	1	1	1	1

Figure 11-6. TIM Counter Modulo Registers (TMODH:TMODL)

NOTE: Reset the TIM counter before writing to the TIM counter modulo registers.

11.10.4 TIM Channel Status and Control Registers

Each of the TIM channel status and control registers does the following:

- Flags input captures and output compares
- Enables input capture and output compare interrupts
- Selects input capture, output compare, or PWM operation
- Selects high, low, or toggling output on output compare
- Selects rising edge, falling edge, or any edge as the active input capture trigger
- Selects output toggling on TIM overflow
- Selects 0% and 100% PWM duty cycle
- Selects buffered or unbuffered output compare/PWM operation

TSC0 Address: \$0010

	Bit 7	6	5	4	3	2	1	Bit 0
Read:	CH0F	CH0IE	MS0B	MS0A	ELS0B	ELS0A	TOV0	CH0MAX
Write:	0							
Reset:	0	0	0	0	0	0	0	0

TSC1 Address: \$0013

	Bit 7	6	5	4	3	2	1	Bit 0
Read:	CH1F	CH1IE	0	MS1A	ELS1B	ELS1A	TOV1	CH1MAX
Write:	0							
Reset:	0	0	0	0	0	0	0	0

 = Unimplemented

Figure 11-7. TIM Channel Status and Control Registers (TSC0:TSC1)

CHxF — Channel x Flag Bit

When channel x is an input capture channel, this read/write bit is set when an active edge occurs on the channel x pin. When channel x is an output compare channel, CHxF is set when the value in the TIM counter registers matches the value in the TIM channel x registers.

When TIM CPU interrupt requests are enabled (CHxIE = 1), clear CHxF by reading the TIM channel x status and control register with CHxF set and then writing a logic 0 to CHxF. If another interrupt request occurs before the clearing sequence is complete, then writing logic 0 to CHxF has no effect. Therefore, an interrupt request cannot be lost due to inadvertent clearing of CHxF.

Reset clears the CHxF bit. Writing a logic 1 to CHxF has no effect.

- 1 = Input capture or output compare on channel x
- 0 = No input capture or output compare on channel x

CHxIE — Channel x Interrupt Enable Bit

This read/write bit enables TIM CPU interrupt service requests on channel x. Reset clears the CHxIE bit.

- 1 = Channel x CPU interrupt requests enabled
- 0 = Channel x CPU interrupt requests disabled

MSxB — Mode Select Bit B

This read/write bit selects buffered output compare/PWM operation. MSxB exists only in the TIM channel 0 status and control register.

Setting MS0B disables the channel 1 status and control register and reverts TCH1 to general-purpose I/O.

Reset clears the MSxB bit.

- 1 = Buffered output compare/PWM operation enabled
- 0 = Buffered output compare/PWM operation disabled

MSxA — Mode Select Bit A

When ELSxB:ELSxA \neq 0:0, this read/write bit selects either input capture operation or unbuffered output compare/PWM operation.

See [Table 11-3](#).

- 1 = Unbuffered output compare/PWM operation
- 0 = Input capture operation

When ELSxB:ELSxA = 0:0, this read/write bit selects the initial output level of the TCHx pin. (See [Table 11-3](#).) Reset clears the MSxA bit.

- 1 = Initial output level low
- 0 = Initial output level high

NOTE: Before changing a channel function by writing to the MSxB or MSxA bit, set the TSTOP and TRST bits in the TIM status and control register (TSC).

ELSxB and ELSxA — Edge/Level Select Bits

When channel x is an input capture channel, these read/write bits control the active edge-sensing logic on channel x.

When channel x is an output compare channel, ELSxB and ELSxA control the channel x output behavior when an output compare occurs.

When ELSxB and ELSxA are both clear, channel x is not connected to port E, and pin PTE_x/TCH_x is available as a general-purpose I/O pin. [Table 11-3](#) shows how ELSxB and ELSxA work. Reset clears the ELSxB and ELSxA bits.

Table 11-3. Mode, Edge, and Level Selection

MSxB	MSxA	ELSxB	ELSxA	Mode	Configuration
X	0	0	0	Output Preset	Pin under port control; initial output level high
X	1	0	0		Pin under port control; initial output level low
0	0	0	1	Input Capture	Capture on rising edge only
0	0	1	0		Capture on falling edge only
0	0	1	1		Capture on rising or falling edge
0	1	0	1	Output Compare or PWM	Toggle output on compare
0	1	1	0		Clear output on compare
0	1	1	1		Set output on compare
1	X	0	1	Buffered Output Compare or Buffered PWM	Toggle output on compare
1	X	1	0		Clear output on compare
1	X	1	1		Set output on compare

NOTE: Before enabling a TIM channel register for input capture operation, make sure that the PTE_x/TCH_x pin is stable for at least two bus clocks.

TOV_x — Toggle-On-Overflow Bit

When channel x is an output compare channel, this read/write bit controls the behavior of the channel x output when the TIM counter overflows. When channel x is an input capture channel, TOV_x has no effect. Reset clears the TOV_x bit.

1 = Channel x pin toggles on TIM counter overflow

0 = Channel x pin does not toggle on TIM counter overflow

NOTE: When TOV_x is set, a TIM counter overflow takes precedence over a channel x output compare if both occur at the same time.

CH_xMAX — Channel x Maximum Duty Cycle Bit

When the TOV_x bit is at logic 1, setting the CH_xMAX bit forces the duty cycle of buffered and unbuffered PWM signals to 100%. As [Figure 11-8](#) shows, the CH_xMAX bit takes effect in the cycle after it is set or cleared. The output stays at the 100% duty cycle level until the cycle after CH_xMAX is cleared.

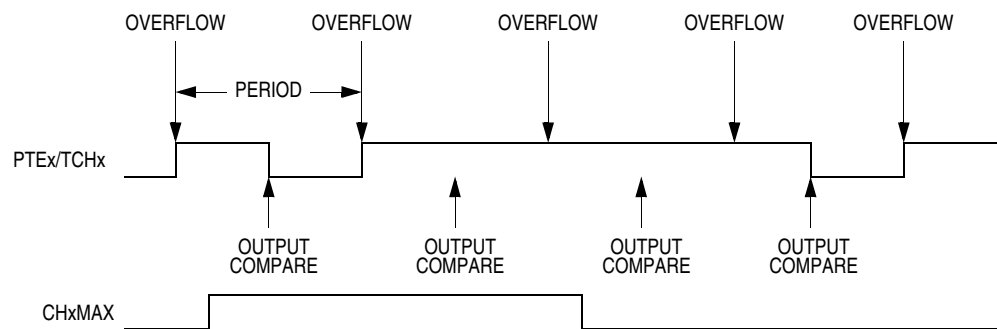

Figure 11-8. CH_xMAX Latency

11.10.5 TIM Channel Registers

These read/write registers contain the captured TIM counter value of the input capture function or the output compare value of the output compare function. The state of the TIM channel registers after reset is unknown.

In input capture mode ($MSxB:MSxA = 0:0$), reading the high byte of the TIM channel x registers (TCHxH) inhibits input captures until the low byte (TCHxL) is read.

In output compare mode ($MSxB:MSxA \neq 0:0$), writing to the high byte of the TIM channel x registers (TCHxH) inhibits output compares until the low byte (TCHxL) is written.

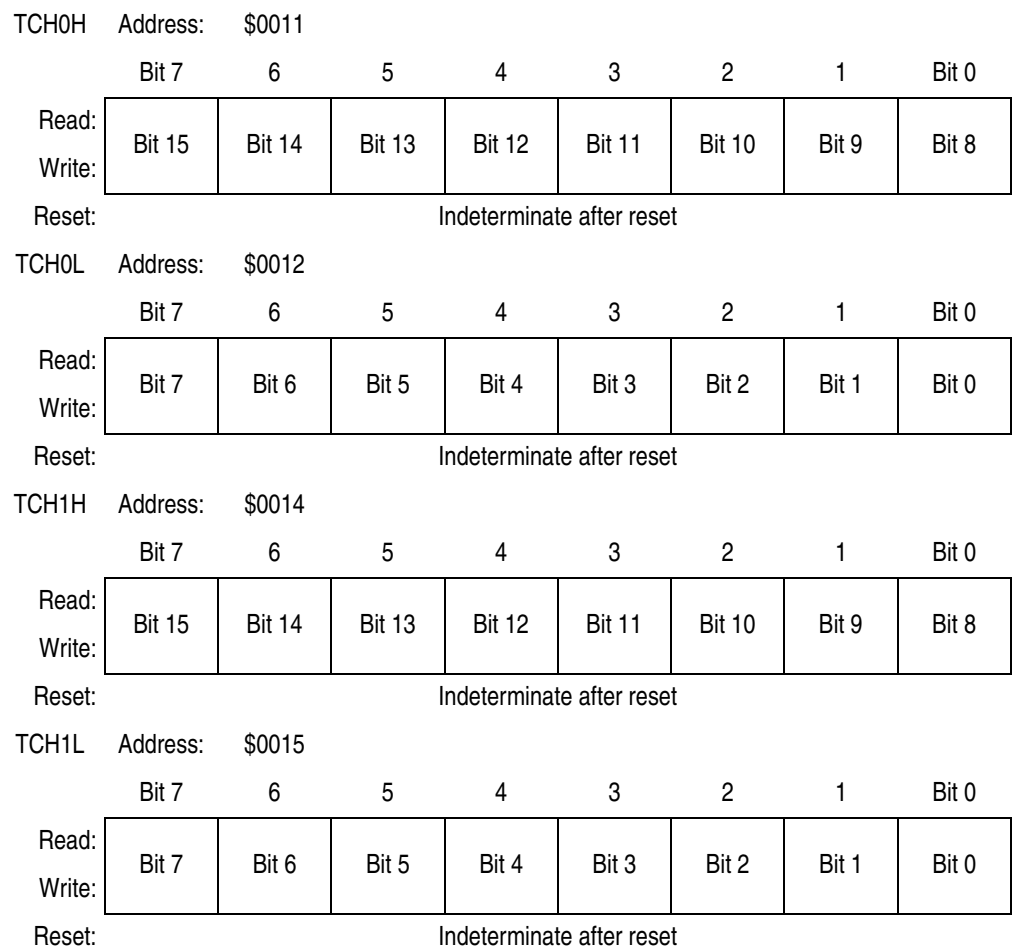

Figure 11-9. TIM Channel Registers (TCH0H/L:TCH1H/L)

Section 12. Input/Output Ports (I/O)

12.1 Contents

12.2	Introduction	199
12.3	Port A	202
12.3.1	Port A Data Register	202
12.3.2	Data Direction Register A.	203
12.4	Port B	204
12.4.1	Port B Data Register	204
12.4.2	Data Direction Register B.	205
12.5	Port C	207
12.5.1	Port C Data Register	207
12.5.2	Data Direction Register C.	208
12.6	Port D	209
12.6.1	Port D Data Register	210
12.6.2	Data Direction Register D.	211
12.7	Port E	212
12.7.1	Port E Data Register	213
12.7.2	Data Direction Register E.	215
12.8	Port Options	216
12.8.1	Port Option Control Register	217

12.2 Introduction

Thirty-seven (37) bidirectional input-output (I/O) pins form five parallel ports. All I/O pins are programmable as inputs or outputs.

NOTE: Connect any unused I/O pins to an appropriate logic level, either V_{REG} or V_{SS} . Although the I/O ports do not require termination for proper operation, termination reduces excess current consumption and the possibility of electrostatic damage.

Addr.	Register Name	Bit 7	6	5	4	3	2	1	Bit 0
\$0000	Port A Data Register (PTA)	Read: PTA7 Write: PTA7	PTA6	PTA5	PTA4	PTA3	PTA2	PTA1	PTA0
		Reset: Unaffected by reset							
\$0001	Port B Data Register (PTB)	Read: PTB7 Write: PTB7	PTB6	PTB5	PTB4	PTB3	PTB2	PTB1	PTB0
		Reset: Unaffected by reset							
\$0002	Port C Data Register (PTC)	Read: PTC7 Write: PTC7	PTC6	PTC5	PTC4	PTC3	PTC2	PTC1	PTC0
		Reset: Unaffected by reset							
\$0003	Port D Data Register (PTD)	Read: PTD7 Write: PTD7	PTD6	PTD5	PTD4	PTD3	PTD2	PTD1	PTD0
		Reset: Unaffected by reset							
\$0004	Data Direction Register A (DDRA)	Read: DDRA7 Write: DDRA7	DDRA6	DDRA5	DDRA4	DDRA3	DDRA2	DDRA1	DDRA0
		Reset: 0*	0	0	0	0	0	0	0
* DDRA7 bit is reset by POR or LVI reset only.									
\$0005	Data Direction Register B (DDRB)	Read: DDRB7 Write: DDRB7	DDRB6	DDRB5	DDRB4	DDRB3	DDRB2	DDRB1	DDRB0
		Reset: 0	0	0	0	0	0	0	0
\$0006	Data Direction Register C (DDRC)	Read: DDRC7 Write: DDRC7	DDRC6	DDRC5	DDRC4	DDRC3	DDRC2	DDRC1	DDRC0
		Reset: 0	0	0	0	0	0	0	0
\$0007	Data Direction Register D (DDRD)	Read: DDRD7 Write: DDRD7	DDRD6	DDRD5	DDRD4	DDRD3	DDRD2	DDRD1	DDRD0
		Reset: 0	0	0	0	0	0	0	0
\$0008	Port E Data Register (PTE)	Read: 0 Write: [Unimplemented]	0	0	PTE4	PTE3	PTE2	PTE1	PTE0
		Reset: Unaffected by reset							
		[Unimplemented] = Unimplemented							

Figure 12-1. I/O Port Register Summary

Addr.	Register Name	Bit 7	6	5	4	3	2	1	Bit 0	
\$0009	Data Direction Register E (DDRE)	Read:	0	0	0	DDRE4	DDRE3	DDRE2	DDRE1	DDRE0
		Write:								
		Reset:	0	0	0	0	0	0	0	0
\$001D	Port Option Control Register (POCR)	Read:	PTE20P	PTDLDD	PTDILDD	PTE4P	PTE3P	PCP	PBP	PAP
		Write:								
		Reset:	0	0	0	0	0	0	0	0

= Unimplemented

Figure 12-1. I/O Port Register Summary
Table 12-1. Port Control Register Bits Summary

Port	Bit	DDR	Module Control			Pin
			Module	Register	Control Bit	
A	0	DDRA0	KBI	KBIER (\$0017)	KBIE0	PTA0/ $\overline{\text{KBA0}}$
	1	DDRA1			KBIE1	PTA1/ $\overline{\text{KBA1}}$
	2	DDRA2			KBIE2	PTA2/ $\overline{\text{KBA2}}$
	3	DDRA3			KBIE3	PTA3/ $\overline{\text{KBA3}}$
	4	DDRA4			KBIE4	PTA4/ $\overline{\text{KBA4}}$
	5	DDRA5			KBIE5	PTA5/ $\overline{\text{KBA5}}$
	6	DDRA6			KBIE6	PTA6/ $\overline{\text{KBA6}}$
	7	DDRA7			KBIE7	PTA7/ $\overline{\text{KBA7}}$
B	0–7	DDRB[0:7]	—	—	—	PTB0–PTB7
C	0–7	DDRC[0:7]	—	—	—	PTC0–PTC7
D	0–7	DDRD[0:7]	—	—	—	PTD0–PTD7
E	0	DDRE0	TIM	TSC (\$000A)	PS[2:0]	PTE0/TCLK
	1	DDRE1		TSC0 (\$0010)	ELS0B:ELS0A	PTE1/TCH0
	2	DDRE2		TSC1 (\$0013)	ELS1B:ELS1A	PTE2/TCH1
	3	DDRE3	USB	UADDR (\$0038)	USBEN	PTE3/D+
	4	DDRE4				PTE4/D–

12.3 Port A

Port A is an 8-bit general-purpose bidirectional I/O port with software configurable pullups, and it shares its pins with the keyboard interrupt module (KBI).

12.3.1 Port A Data Register

The port A data register contains a data latch for each of the eight port A pins.

Address: \$0000

	Bit 7	6	5	4	3	2	1	Bit 0
Read:	PTA7	PTA6	PTA5	PTA4	PTA3	PTA2	PTA1	PTA0
Write:								
Reset:	Unaffected by reset							
Alternative Function:	$\overline{\text{KBA7}}$	$\overline{\text{KBA6}}$	$\overline{\text{KBA5}}$	$\overline{\text{KBA4}}$	$\overline{\text{KBA3}}$	$\overline{\text{KBA2}}$	$\overline{\text{KBA1}}$	$\overline{\text{KBA0}}$
Additional Function:	Optional pullup	Optional pullup	Optional pullup	Optional pullup	Optional pullup	Optional pullup	Optional pullup	Optional pullup

Figure 12-2. Port A Data Register (PTA)

PTA[7:0] — Port A Data Bits

These read/write bits are software programmable. Data direction of each port A pin is under the control of the corresponding bit in data direction register A. Reset has no effect on port A data.

The port A pullup enable bit, PAP, in the port option control register (POCR) enables pullups on port A pins if the respective pin is configured as an input. (See [12.8 Port Options](#).)

$\overline{\text{KBA7}}\text{--}\overline{\text{KBA0}}$ — Keyboard Interrupts

The keyboard interrupt enable bits, KBIE7–KBIE0, in the keyboard interrupt enable register (KBIER), enable the port A pins as external interrupt pins. (See [Section 14. Keyboard Interrupt Module \(KBI\)](#).)

12.3.2 Data Direction Register A

Data direction register A determines whether each port A pin is an input or an output. Writing a logic 1 to a DDRA bit enables the output buffer for the corresponding port A pin; a logic 0 disables the output buffer.

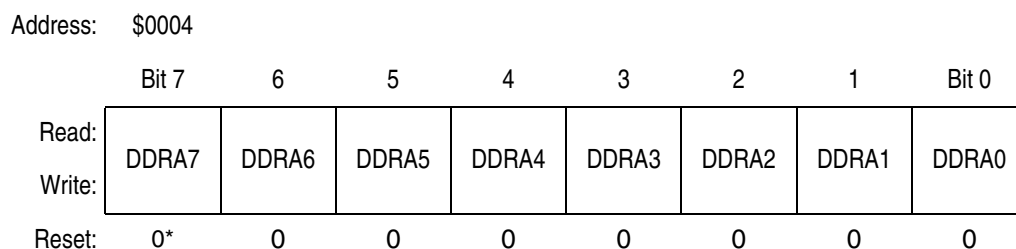

* DDRA7 bit is reset by POR or LVI reset only.

Figure 12-3. Data Direction Register A (DDRA)

DDRA[7:0] — Data Direction Register A Bits

These read/write bits control port A data direction. Reset clears DDRA[7:0], configuring all port A pins as inputs.

1 = Corresponding port A pin configured as output

0 = Corresponding port A pin configured as input

NOTE: Avoid glitches on port A pins by writing to the port A data register before changing data direction register A bits from 0 to 1.

Figure 12-4 shows the port A I/O logic.

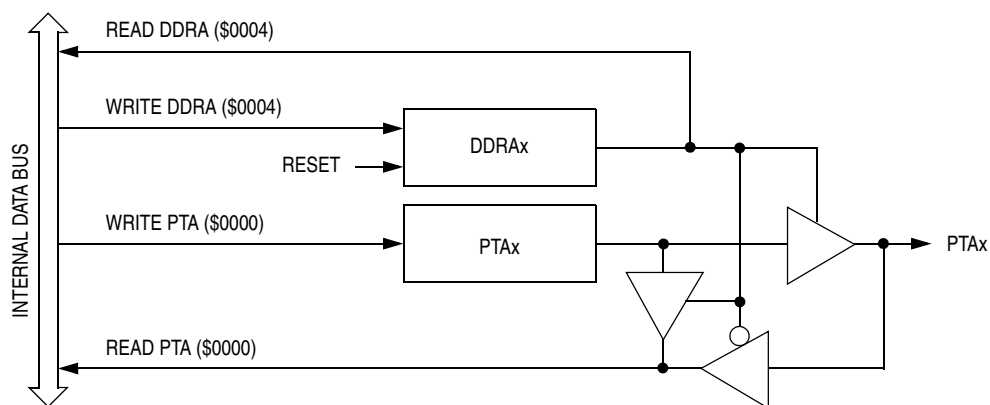

Figure 12-4. Port A I/O Circuit

When bit DDRAx is a logic 1, reading address \$0000 reads the PTAx data latch. When bit DDRAx is a logic 0, reading address \$0000 reads the voltage level on the pin. The data latch can always be written, regardless of the state of its data direction bit. **Table 12-2** summarizes the operation of the port A pins.

Table 12-2. Port A Pin Functions

DDRA Bit	PTA Bit	I/O Pin Mode	Accesses to DDRA	Accesses to PTA	
			Read/Write	Read	Write
0	X ⁽¹⁾	Input, Hi-Z ⁽²⁾	DDRA[7:0]	Pin	PTA[7:0] ⁽³⁾
1	X	Output	DDRA[7:0]	PTA[7:0]	PTA[7:0]

NOTES:

1. X = don't care.
2. Hi-Z = high impedance.
3. Writing affects data register, but does not affect input.

12.4 Port B

Port B is an 8-bit general-purpose bidirectional I/O port with software configurable pullups.

12.4.1 Port B Data Register

The port B data register contains a data latch for each of the eight port B pins.

NOTE: *PTB7–PTB0 are not available in the 20-pin PDIP, 20-pin SOIC, and 28-pin SOIC packages.*

Address: \$0001

	Bit 7	6	5	4	3	2	1	Bit 0
Read:	PTB7	PTB6	PTB5	PTB4	PTB3	PTB2	PTB1	PTB0
Write:								
Reset:	Unaffected by reset							
Additional Function:	Optional pullup	Optional pullup	Optional pullup	Optional pullup	Optional pullup	Optional pullup	Optional pullup	Optional pullup

Figure 12-5. Port B Data Register (PTB)

PTB[7:0] — Port B Data Bits

These read/write bits are software-programmable. Data direction of each port B pin is under the control of the corresponding bit in data direction register B. Reset has no effect on port B data.

The port B pullup enable bit, PBP, in the port option control register (POCR) enables pullups on port B pins if the respective pin is configured as an input. (See [12.8 Port Options](#).)

12.4.2 Data Direction Register B

Data direction register B determines whether each port B pin is an input or an output. Writing a logic 1 to a DDRB bit enables the output buffer for the corresponding port B pin; a logic 0 disables the output buffer.

Address: \$0005

	Bit 7	6	5	4	3	2	1	Bit 0
Read:	DDRB7	DDRB6	DDRB5	DDRB4	DDRB3	DDRB2	DDRB1	DDRB0
Write:	DDRB7	DDRB6	DDRB5	DDRB4	DDRB3	DDRB2	DDRB1	DDRB0
Reset:	0	0	0	0	0	0	0	0

Figure 12-6. Data Direction Register B (DDRB)

DDRB[7:0] — Data Direction Register B Bits

These read/write bits control port B data direction. Reset clears DDRB[7:0], configuring all port B pins as inputs.

1 = Corresponding port B pin configured as output

0 = Corresponding port B pin configured as input

NOTE: *Avoid glitches on port B pins by writing to the port B data register before changing data direction register B bits from 0 to 1.*

NOTE: *For those devices packaged in a 20-pin PDIP, 20-pin SOIC, and 28-pin SOIC package, PTB7–PTB0 are not connected. DDRB7–DDRB0 should be set to a 1 to configure PTB7–PTB0 as outputs.*

Figure 12-7 shows the port B I/O logic.

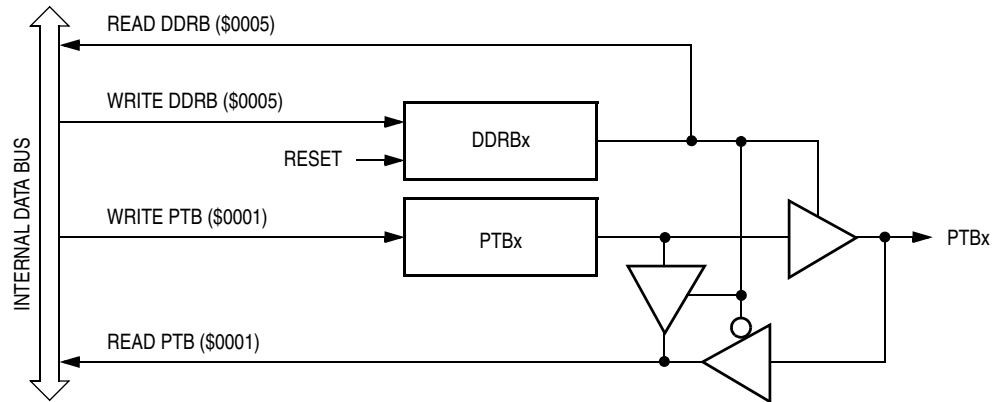

Figure 12-7. Port B I/O Circuit

When bit DDRBx is a logic 1, reading address \$0001 reads the PTBx data latch. When bit DDRBx is a logic 0, reading address \$0001 reads the voltage level on the pin. The data latch can always be written, regardless of the state of its data direction bit. [Table 12-3](#) summarizes the operation of the port B pins.

Table 12-3. Port B Pin Functions

DDR Bit	PTB Bit	I/O Pin Mode	Accesses to DDRB	Accesses to PTB	
			Read/Write	Read	Write
0	X ⁽¹⁾	Input, Hi-Z ⁽²⁾	DDR[7:0]	Pin	PTB[7:0] ⁽³⁾
1	X	Output	DDR[7:0]	PTB[7:0]	PTB[7:0]

NOTES:

1. X = don't care.
2. Hi-Z = high impedance.
3. Writing affects data register, but does not affect input.

12.5 Port C

Port C is an 8-bit general-purpose bidirectional I/O port with software configurable pullups and current drive options.

12.5.1 Port C Data Register

The port C data register contains a data latch for each of the eight port C pins.

NOTE: *PTC7–PTC1 are not available in the 20-pin PDIP, 20-pin SOIC, and 28-pin SOIC packages.*

Address: \$0002

	Bit 7	6	5	4	3	2	1	Bit 0
Read:	PTC7	PTC6	PTC5	PTC4	PTC3	PTC2	PTC1	PTC0
Write:	PTC7	PTC6	PTC5	PTC4	PTC3	PTC2	PTC1	PTC0
Reset:	Unaffected by reset							
Additional Function:	Optional pullup	Optional pullup	Optional pullup	Optional pullup	Optional pullup	Optional pullup	Optional pullup	Optional pullup

Figure 12-8. Port C Data Register (PTC)

PTC[7:0] — Port C Data Bits

These read/write bits are software-programmable. Data direction of each port C pin is under the control of the corresponding bit in data direction register C. Reset has no effect on port C data.

The port C pullup enable bit, PCP, in the port option control register (POCR) enables pullups on port C pins if the respective pin is configured as an input. (See [12.8 Port Options](#).)

12.5.2 Data Direction Register C

Data direction register C determines whether each port C pin is an input or an output. Writing a logic 1 to a DDRC bit enables the output buffer for the corresponding port C pin; a logic 0 disables the output buffer.

Address: \$0006

	Bit 7	6	5	4	3	2	1	Bit 0
Read:	DDRC7	DDRC6	DDRC5	DDRC4	DDRC3	DDRC2	DDRC1	DDRC0
Write:								
Reset:	0	0	0	0	0	0	0	0

Figure 12-9. Data Direction Register C (DDRC)

DDRC[7:0] — Data Direction Register C Bits

These read/write bits control port C data direction. Reset clears DDRC[7:0], configuring all port C pins as inputs.

1 = Corresponding port C pin configured as output

0 = Corresponding port C pin configured as input

NOTE: *Avoid glitches on port C pins by writing to the port C data register before changing data direction register C bits from 0 to 1.*

NOTE: *For those devices packaged in a 20-pin PDIP, 20-pin SOIC, and 28-pin SOIC package, PTC7–PTC1 are not connected. DDRC7–DDRC1 should be set to a 1 to configure PTC7–PTC1 as outputs.*

Figure 12-10 shows the port C I/O logic.

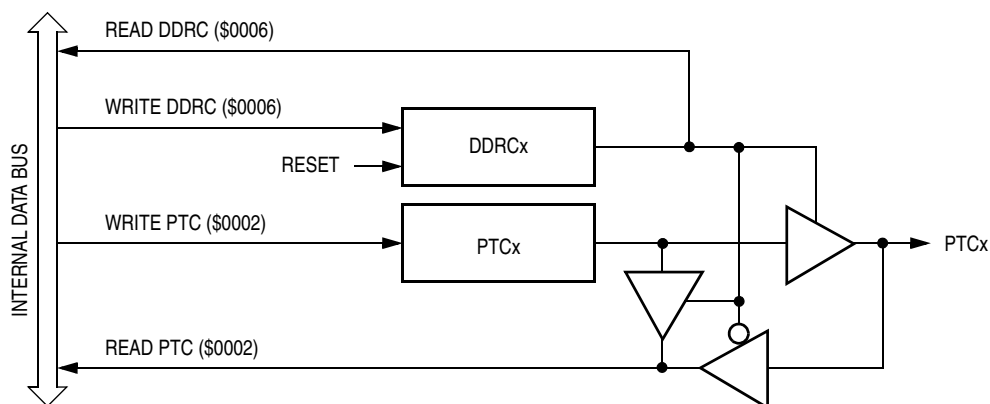

Figure 12-10. Port C I/O Circuit

When bit DDRCx is a logic 1, reading address \$0002 reads the PTCx data latch. When bit DDRCx is a logic 0, reading address \$0002 reads the voltage level on the pin. The data latch can always be written, regardless of the state of its data direction bit. [Table 12-4](#) summarizes the operation of the port C pins.

Table 12-4. Port C Pin Functions

DDRC Bit	PTC Bit	I/O Pin Mode	Accesses to DDRC	Accesses to PTC	
			Read/Write	Read	Write
0	X ⁽¹⁾	Input, Hi-Z ⁽²⁾	DDRC[7:0]	Pin	PTC[7:0] ⁽³⁾
1	X	Output	DDRC[7:0]	PTC[7:0]	PTC[7:0]

NOTES:

1. X = don't care.
2. Hi-Z = high impedance.
3. Writing affects data register, but does not affect input.

12.6 Port D

Port D is an 8-bit general-purpose bidirectional I/O port. In 20-pin package, PTD1 and PTD0 internal pads are bonded together to PTD0/1 pin. Port D pins are open-drain when configured as output, and can interface with 5V logic.

12.6.1 Port D Data Register

The port D data register contains a data latch for each of the eight port D pins.

NOTE: *PTD7–PTD2 are not available in the 20-pin PDIP and 20-pin SOIC packages. PTD7 is not available in the 28-pin SOIC package.*

Address: \$0003

	Bit 7	6	5	4	3	2	1	Bit 0
Read:	PTD7	PTD6	PTD5	PTD4	PTD3	PTD2	PTD1	PTD0
Write:	PTD7	PTD6	PTD5	PTD4	PTD3	PTD2	PTD1	PTD0
Reset:	Unaffected by reset							
Additional Function:	Open-drain	Open-drain	Open-drain	Open-drain	Open-drain	Open-drain	Open-drain	Open-drain
			10mA sink	10mA sink	10mA sink	10mA sink	25mA sink	25mA sink

Figure 12-11. Port D Data Register (PTD)

PTD[7:0] — Port D Data Bits

These read/write bits are software programmable. Data direction of each port D pin is under control of the corresponding bit in data direction register D. Reset has no effect on port D data.

The LED direct drive bit, PTDLDD, in the port option control register (POCR) controls the drive options for the PTD5–PTD2 pins. The infrared LED drive bit, PTDILDD, in the POCR controls the drive options for the PTD1–PTD0 pins. (See [12.8 Port Options](#).)

NOTE: *In 20-pin package, PTD1 and PTD0 are bonded together to PTD0/1 pin, forming a 50mA high current sink pin. When both PTD1 and PTD0 are configured as output, the values of PTD0 and PTD1 should be written the same.*

12.6.2 Data Direction Register D

Data direction register D determines whether each port D pin is an input or an output. Writing a logic 1 to a DDRD bit enables the output buffer for the corresponding port D pin; a logic 0 disables the output buffer.

Address: \$0007

	Bit 7	6	5	4	3	2	1	Bit 0
Read:	DDRD7	DDRD6	DDRD5	DDRD4	DDRD3	DDRD2	DDRD1	DDRD0
Write:								
Reset:	0	0	0	0	0	0	0	0

Figure 12-12. Data Direction Register D (DDRD)

DDRD[7:0] — Data Direction Register D Bits

These read/write bits control port D data direction. Reset clears DDRD[7:0], configuring all port D pins as inputs.

1 = Corresponding port D pin configured as output

0 = Corresponding port D pin configured as input

Port D pins are open-drain when configured as output.

NOTE: *Avoid glitches on port D pins by writing to the port D data register before changing data direction register D bits from 0 to 1.*

NOTE: *For those devices packaged in a 20-pin PDIP and 20-pin SOIC package, PTD7–PTD2 are not connected. DDRD7–DDRD2 should be set to a 1 to configure PTD7–PTD2 as outputs.*

For those devices packaged in a 28-pin SOIC package, PTD7 is not connected. DDRD7 should be set to a 1 to configure PTD7 as output.

Figure 12-13 shows the port D I/O circuit logic.

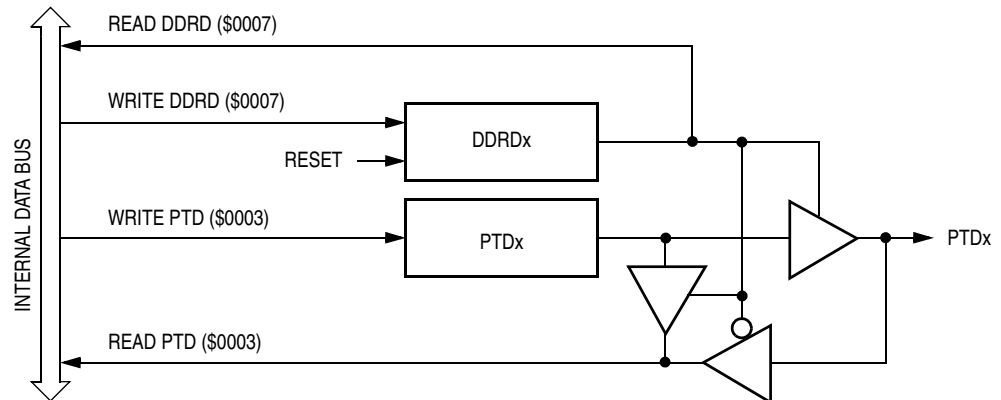

Figure 12-13. Port D I/O Circuit

When bit DDRDx is a logic 1, reading address \$0003 reads the PTDx data latch. When bit DDRDx is a logic 0, reading address \$0003 reads the voltage level on the pin. The data latch can always be written, regardless of the state of its data direction bit. [Table 12-5](#) summarizes the operation of the port D pins.

Table 12-5. Port D Pin Functions

DDRD Bit	PTD Bit	I/O Pin Mode	Accesses to DDRD	Accesses to PTD	
			Read/Write	Read	Write
0	X ⁽¹⁾	Input, Hi-Z ⁽²⁾	DDRD[7:0]	Pin	PTD[7:0] ⁽³⁾
1	X	Output	DDRD[7:0]	PTD[7:0]	PTD[7:0]

NOTES:

1. X = don't care.
2. Hi-Z = high impedance.
3. Writing affects data register, but does not affect input.

12.7 Port E

Port E is a 5-bit special function port that shares three of its pins with the timer interface module (TIM) and two of its pins with the USB data pins D+ and D-. PTE4 and PTE3 are open drain when configured as output.

12.7.1 Port E Data Register

The port E data register contains a data latch for each of the five port E pins.

NOTE: *PTE2 and PTE0 are not available in the 20-pin PDIP and 20-pin SOIC packages.*

Address: \$0008

	Bit 7	6	5	4	3	2	1	Bit 0
Read:	0	0	0	PTE4	PTE3	PTE2	PTE1	PTE0
Write:								
Reset:	Unaffected by reset							
Alternative Function:				D-	D+	TCH1	TCH0	TCLK
Additional Function:				Optional pullup	Optional pullup	Optional pullup	Optional pullup	Optional pullup
Additional Function:				External interrupt				
				Open-drain	Open-drain			

 = Unimplemented

Figure 12-14. Port E Data Register (PTE)

PTE[4:0] — Port E Data Bits

PTE[4:0] are read/write, software-programmable bits. Data direction of each port E pin is under the control of the corresponding bit in data direction register E.

The PTE4 and PTE3 pullup enable bits, PTE4P and PTE3P, in the port option control register (POCR) enable 5 kΩ pullups on PTE4 and PTE3 if the respective pin is configured as an input and the USB module is disabled. (See [12.8 Port Options](#).)

The PTE[2:0] pullup enable bit, PTE20P, in the port option control register (POCR) enables pullups on PTE2–PTE0, regardless of the pin is configured as an input or an output. (See [12.8 Port Options](#).)

PTE4 pin functions as an external interrupt when PTE4IE=1 in the IRQ option control register (IOCR) and USBEN=0 in the USB address register (USB disabled). (See [13.9 IRQ Option Control Register](#).)

D– and D+ — USB Data Pins

D– and D+ are the differential data lines used by the USB module. (See [Section 9. Universal Serial Bus Module \(USB\)](#).)

The USB module enable bit, USBEN, in the USB address register (UADDR) controls the pin options for PTE4/D– and PTE3/D+. When the USB module is enabled, PTE4/D– and PTE3/D+ function as USB data pins D– and D+. When the USB module is disabled, PTE4/D– and PTE3/D+ function as 10mA open-drain pins for PS/2 clock and data use.

The Pullup enable bit, PULLEN, in the USB control register 3 (UCR3) enables a 1.5k Ω pullup on D– pin when the USB module is enabled. (See [9.8.8 USB Control Register 3](#).)

NOTE: *PTE4/D– pin has two programmable pullup resistors. One is used for PTE4 when the USB module is disabled and another is used for D– when the USB module is enabled.*

TCH1–TCH0 — Timer Channel I/O Bits

The PTE2/TCH1–PTE1/TCH0 pins are the TIM input capture/output compare pins. The edge/level select bits, ELSxB and ELSxA, determine whether the PTE2/TCH1–PTE1/TCH0 pins are timer channel I/O pins or general-purpose I/O pins. (See [Section 11. Timer Interface Module \(TIM\)](#).)

TCLK — Timer Clock Input

The PTE0/TCLK pin is the external clock input for the TIM. The prescaler select bits, PS[2:0], select PTE0/TCLK as the TIM clock input. When not selected as the TIM clock, PTE0/TCLK is available for general purpose I/O. (See [Section 11. Timer Interface Module \(TIM\)](#).)

NOTE: *Data direction register E (DDRE) does not affect the data direction of port E pins that are being used by the TIM. However, the DDRE bits always determine whether reading port E returns the states of the latches or the states of the pins.*

12.7.2 Data Direction Register E

Data direction register E determines whether each port E pin is an input or an output. Writing a logic 1 to a DDRE bit enables the output buffer for the corresponding port E pin; a logic 0 disables the output buffer.

Address: \$0009

	Bit 7	6	5	4	3	2	1	Bit 0
Read:	0	0	0	DDRE4	DDRE3	DDRE2	DDRE1	DDRE0
Write:								
Reset:	0	0	0	0	0	0	0	0

= Unimplemented

Figure 12-15. Data Direction Register E (DDRE)

DDRE[4:0] — Data Direction Register E Bits

These read/write bits control port E data direction. Reset clears DDRE[4:0], configuring all port E pins as inputs.

1 = Corresponding port E pin configured as output

0 = Corresponding port E pin configured as input

PTE4 and PTE3 pins are open-drain when configured as output.

NOTE: *Avoid glitches on port E pins by writing to the port E data register before changing data direction register E bits from 0 to 1.*

NOTE: *For those devices packaged in a 20-pin PDIP and 20-pin SOIC package, PTE2 and PTE0 are not connected. DDRE2 and DDRE0 should be set to a 1 to configure PTE2 and PTE0 as outputs.*

Figure 12-16 shows the port E I/O circuit logic.

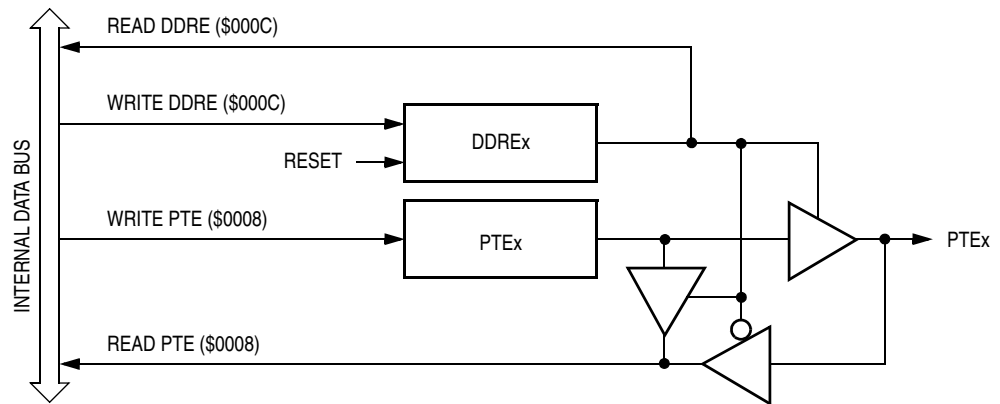

Figure 12-16. Port E I/O Circuit

When bit DDREx is a logic 1, reading address \$0008 reads the PTEx data latch. When bit DDREx is a logic 0, reading address \$0008 reads the voltage level on the pin. The data latch can always be written, regardless of the state of its data direction bit. [Table 12-4](#) summarizes the operation of the port E pins.

Table 12-6. Port E Pin Functions

DDRE Bit	PTE Bit	I/O Pin Mode	Accesses to DDRE	Accesses to PTE	
			Read/Write	Read	Write
0	X ⁽¹⁾	Input, Hi-Z ⁽²⁾	DDRE[4:0]	Pin	PTE[4:0] ⁽³⁾
1	X	Output	DDRE[4:0]	PTE[4:0]	PTE[4:0]

NOTES:

1. X = don't care.
2. Hi-Z = high impedance.
3. Writing affects data register, but does not affect input.

12.8 Port Options

All pins of port A, port B, port C, and port E have programmable pullup resistors. Port pins PTD5–PTD0 have LED drive capability. Port pins PTE4 and PTE3 have 10mA high current drive capability.

12.8.1 Port Option Control Register

The port option control register controls the pullup options for port A, B, C, and E pins. It also controls the drive configuration on port D.

Address: \$001D

	Bit 7	6	5	4	3	2	1	Bit 0
Read:	PTE20P	PTDLDD	PTDILDD	PTE4P	PTE3P	PCP	PBP	PAP
Write:								
Reset:	0	0	0	0	0	0	0	0

Figure 12-17. Port Option Control Register (POCR)

PTE20P — Port PTE2–PTE0 Pullup Enable

This read/write bit controls the pullup option for the PTE2–PTE0 pins, regardless whether the pins are input or output.

- 1 = Configure PTE2–PTE0 to have internal pullups to V_{REG}
- 0 = Disconnect PTE2–PTE0 internal pullups

PTDLDD — LED Direct Drive Control

This read/write bit controls the output current capability of PTD5–PTD2 pins. When set, each port pin has 10mA current sink limit. An LED can be connected directly between the port pin and V_{DD} without the need of a series resistor.

- 1 = PTD5–PTD2 configured for direct LED drive capability; when a pin is set as an output, the pin is an open-drain pin with 10mA current sink limit
- 0 = PTD5–PTD2 configured as standard open-drain I/O port pin

PTDILDD — Infrared LED Drive Control

This read/write bit controls the output current capability of PTD1 and PTD0 pins. When set, each port pin has 25mA current sink capability. An infrared LED can be connected directly between the port pin and V_{DD} .

- 1 = PTD1 and PTD0 configured for infrared LED drive capability; when a pin is set as an output, the pin is an open-drain pin with 25mA current sink capability
- 0 = PTD1 and PTD0 configured as standard open-drain I/O port pins

PTE4P — Pin PTE4 Pullup Enable

This read/write bit controls the pullup option for the PTE4 pin when the pin is configured as an input and the USB module is disabled.

1 = Configure PTE4 to have internal pullup to V_{DD}

0 = Disconnect PTE4 internal pullup

NOTE: *When the USB module is enabled, the pullup controlled by PTE4P is disconnected; PTE4/D⁻ pin functions as D⁻ which has a 1.5k Ω programmable pullup resistor. (See [9.8.8 USB Control Register 3](#).)*

PTE3P — Pin PTE3 Pullup Enable

This read/write bit controls the pullup option for the PTE3 pin when the pin is configured as an input and the USB module is disabled.

1 = Configure PTE3 to have internal pullup to V_{DD}

0 = Disconnect PTE3 internal pullup

PCP — Port C Pullup Enable

This read/write bit controls the pullup option for the PTC7–PTC0 pins. When set, a pullup device is connected when a pin is configured as an input.

1 = Configure port C to have internal pullups to V_{REG}

0 = Disconnect port C internal pullups

PBP — Port B Pullup Enable

This read/write bit controls the pullup option for the PTB7–PTB0 pins. When set, a pullup device is connected when a pin is configured as an input.

1 = Configure port B to have internal pullups to V_{REG}

0 = Disconnect port B internal pullups

PAP — Port A Pullup Enable

This read/write bit controls the pullup option for the PTA7–PTA0 pins. When set, a pullup device is connected when a pin is configured as an input.

1 = Configure port A to have internal pullups to V_{REG}

0 = Disconnect port A internal pullups

Section 13. External Interrupt (IRQ)

13.1 Contents

13.2	Introduction	219
13.3	Features	219
13.4	Functional Description	220
13.5	IRQ Pin	222
13.6	PTE4/D– Pin	223
13.7	IRQ Module During Break Interrupts	223
13.8	IRQ Status and Control Register	224
13.9	IRQ Option Control Register	225

13.2 Introduction

The IRQ module provides two external interrupt inputs: one dedicated $\overline{\text{IRQ}}$ pin and one shared port pin, PTE4/D–.

13.3 Features

Features of the IRQ module include:

- Two external interrupt pins, $\overline{\text{IRQ}}$ (5V) and PTE4/D– (5V)
- $\overline{\text{IRQ}}$ interrupt control bits
- Hysteresis buffer
- Programmable edge-only or edge and level interrupt sensitivity
- Automatic interrupt acknowledge
- Low leakage $\overline{\text{IRQ}}$ pin for external RC wake up input
- Selectable internal pullup resistor

13.4 Functional Description

A logic 0 applied to the external interrupt pin can latch a CPU interrupt request. [Figure 13-1](#) shows the structure of the IRQ module.

Interrupt signals on the $\overline{\text{IRQ}}$ pin are latched into the IRQ latch. An interrupt latch remains set until one of the following actions occurs:

- Vector fetch — A vector fetch automatically generates an interrupt acknowledge signal that clears the IRQ latch.
- Software clear — Software can clear the interrupt latch by writing to the acknowledge bit in the interrupt status and control register (ISCR). Writing a logic 1 to the ACK bit clears the IRQ latch.
- Reset — A reset automatically clears the interrupt latch.

The external interrupt pin is falling-edge-triggered and is software-configurable to be either falling-edge or low-level-triggered. The MODE bit in the ISCR controls the triggering sensitivity of the $\overline{\text{IRQ}}$ pin.

When the interrupt pin is edge-triggered only, the CPU interrupt request remains set until a vector fetch, software clear, or reset occurs.

When the interrupt pin is both falling-edge and low-level-triggered, the CPU interrupt request remains set until both of the following occur:

- Vector fetch or software clear
- Return of the interrupt pin to logic one

The vector fetch or software clear may occur before or after the interrupt pin returns to logic 1. As long as the pin is low, the interrupt request remains pending. A reset will clear the latch and the MODE control bit, thereby clearing the interrupt even if the pin stays low.

When set, the IMASK bit in the ISCR mask all external interrupt requests. A latched interrupt request is not presented to the interrupt priority logic unless the IMASK bit is clear.

NOTE: *The interrupt mask (I) in the condition code register (CCR) masks all interrupt requests, including external interrupt requests. (See [8.6 Exception Control](#).)*

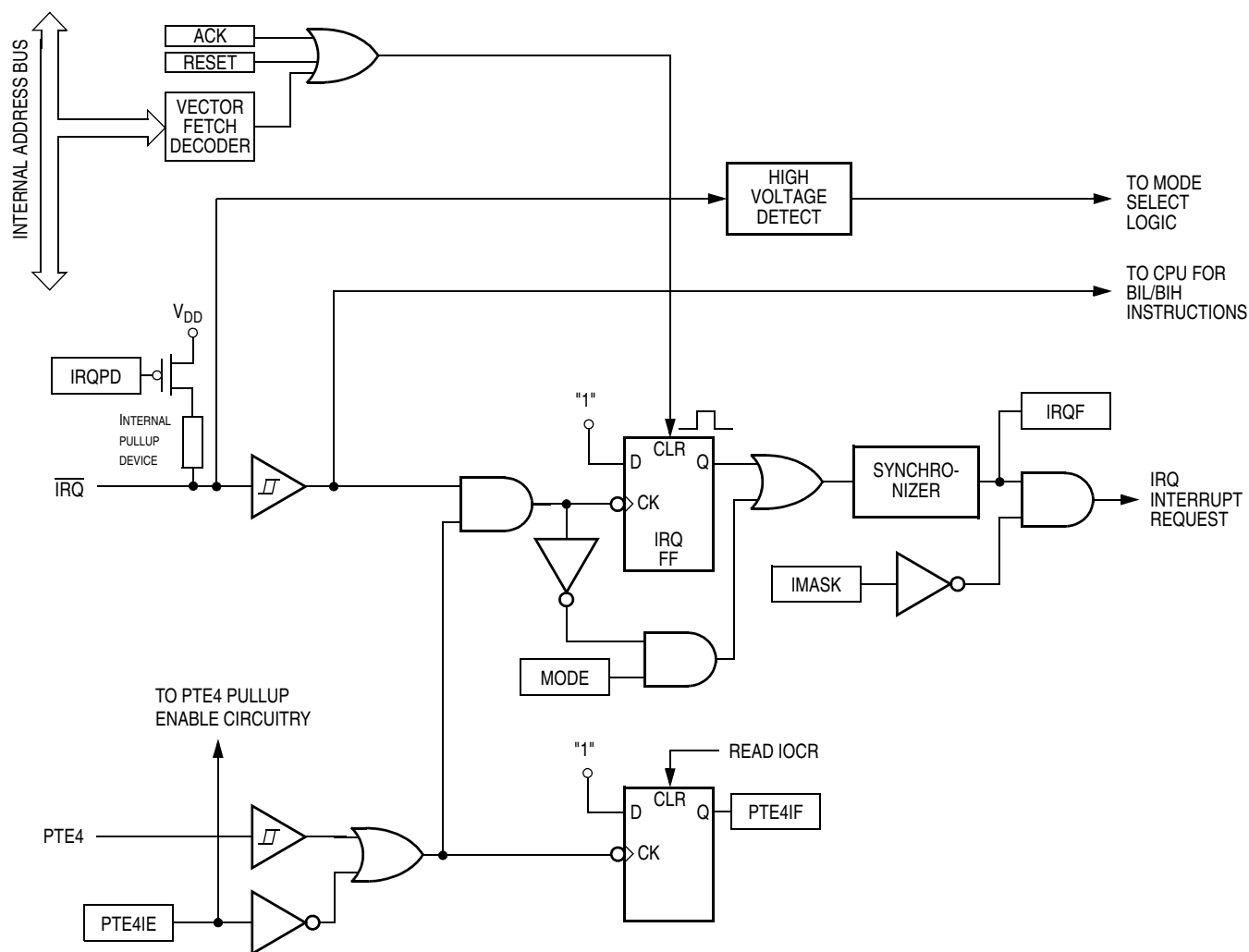

Figure 13-1. IRQ Module Block Diagram

Addr.	Register Name		Bit 7	6	5	4	3	2	1	Bit 0	
\$001C	IRQ Option Control Register (IOCR)	Read:	0	0	0	0	0	PTE4IF	PTE4IE	IRQPD	
		Write:									
		Reset:	0	0	0	0	0	0	0	0	0
\$001E	IRQ Status and Control Register (ISCR)	Read:	0	0	0	0	IRQF	0	IMASK	MODE	
		Write:									ACK
		Reset:	0	0	0	0	0	0	0	0	0

= Unimplemented

Figure 13-2. IRQ I/O Register Summary

13.5 $\overline{\text{IRQ}}$ Pin

The $\overline{\text{IRQ}}$ pin has a low leakage for input voltages ranging from 0V to V_{DD} ; suitable for applications using RC discharge circuitry to wake up the MCU.

A logic 0 on the $\overline{\text{IRQ}}$ pin can latch an interrupt request into the IRQ latch. A vector fetch, software clear, or reset clears the IRQ latch.

If the MODE bit is set, the $\overline{\text{IRQ}}$ pin is both falling-edge-sensitive and low-level-sensitive. With MODE set, both of the following actions must occur to clear IRQ:

- Vector fetch or software clear — A vector fetch generates an interrupt acknowledge signal to clear the latch. Software may generate the interrupt acknowledge signal by writing a logic 1 to the ACK bit in the interrupt status and control register (ISCR). The ACK bit is useful in applications that poll the $\overline{\text{IRQ}}$ pin and require software to clear the IRQ latch. Writing to the ACK bit prior to leaving an interrupt service routine can also prevent spurious interrupts due to noise. Setting ACK does not affect subsequent transitions on the $\overline{\text{IRQ}}$ pin. A falling edge that occurs after writing to the ACK bit latches another interrupt request. If the IRQ mask bit, IMASK, is clear, the CPU loads the program counter with the vector address at locations \$FFF8 and \$FFF9.
- Return of the $\overline{\text{IRQ}}$ pin to logic one — As long as the $\overline{\text{IRQ}}$ pin is at logic zero, IRQ remains active.

The vector fetch or software clear and the return of the $\overline{\text{IRQ}}$ pin to logic one may occur in any order. The interrupt request remains pending as long as the $\overline{\text{IRQ}}$ pin is at logic zero. A reset will clear the latch and the MODE control bit, thereby clearing the interrupt even if the pin stays low.

If the MODE bit is clear, the $\overline{\text{IRQ}}$ pin is falling-edge-sensitive only. With MODE clear, a vector fetch or software clear immediately clears the IRQ latch.

The IRQF bit in the ISCR register can be used to check for pending interrupts. The IRQF bit is not affected by the IMASK bit, which makes it useful in applications where polling is preferred.

Use the BIH or BIL instruction to read the logic level on the $\overline{\text{IRQ}}$ pin.

NOTE: *When using the level-sensitive interrupt trigger, avoid false interrupts by masking interrupt requests in the interrupt routine.*

NOTE: *An internal pullup resistor to V_{DD} is connected to $\overline{\text{IRQ}}$ pin; this can be disabled by setting the IRQPD bit in the IRQ option control register (\$001C).*

13.6 PTE4/D- Pin

The PTE4 pin is configured as an interrupt input to trigger the IRQ interrupt when the following conditions are satisfied:

- The USB module is disabled (USBEN = 0)
- PTE4 pin configured for external interrupt input (PTE4IE = 1)

Setting PTE4IE configures the PTE4 pin to an input pin with an internal pullup device. The PTE4 interrupt is "ORed" with the $\overline{\text{IRQ}}$ input to trigger the IRQ interrupt (see [Figure 13-1 . IRQ Module Block Diagram](#)).

Therefore, the IRQ status and control register affects both the $\overline{\text{IRQ}}$ pin and the PTE pin. An interrupt on PTE4 also sets the PTE4 interrupt flag, PTE4IF, in the IRQ option control register (IOCR).

13.7 IRQ Module During Break Interrupts

The system integration module (SIM) controls whether the IRQ latch can be cleared during the break state. The BCFE bit in the break flag control register (BFCR) enables software to clear the latches during the break state. (See [Section 8. System Integration Module \(SIM\)](#).)

To allow software to clear the IRQ latch during a break interrupt, write a logic 1 to the BCFE bit. If a latch is cleared during the break state, it remains cleared when the MCU exits the break state.

To protect the latches during the break state, write a logic 0 to the BCFE bit. With BCFE at logic 0 (its default state), writing to the ACK bit in the IRQ status and control register during the break state has no effect on the IRQ latch.

13.8 IRQ Status and Control Register

The IRQ status and control register (ISCR) controls and monitors operation of the IRQ module. The ISCR has the following functions:

- Shows the state of the IRQ flag
- Clears the IRQ latch
- Masks IRQ interrupt request
- Controls triggering sensitivity of the $\overline{\text{IRQ}}$ pin

Address: \$001E

	Bit 7	6	5	4	3	2	1	Bit 0
Read:	0	0	0	0	IRQF	0	IMASK	MODE
Write:						ACK		
Reset:	0	0	0	0	0	0	0	0

= Unimplemented

Figure 13-3. IRQ Status and Control Register (ISCR)

IRQF — IRQ Flag

This read-only status bit is high when the IRQ interrupt is pending.

- 1 = IRQ interrupt pending
- 0 = IRQ interrupt not pending

ACK — IRQ Interrupt Request Acknowledge Bit

Writing a logic 1 to this write-only bit clears the IRQ latch. ACK always reads as logic 0. Reset clears ACK.

IMASK — IRQ Interrupt Mask Bit

Writing a logic 1 to this read/write bit disables IRQ interrupt requests. Reset clears IMASK.

- 1 = IRQ interrupt requests disabled
- 0 = IRQ interrupt requests enabled

MODE — IRQ Edge/Level Select Bit

This read/write bit controls the triggering sensitivity of the $\overline{\text{IRQ}}$ pin. Reset clears MODE.

- 1 = $\overline{\text{IRQ}}$ interrupt requests on falling edges and low levels

0 = $\overline{\text{IRQ}}$ interrupt requests on falling edges only

13.9 IRQ Option Control Register

The IRQ option control register controls and monitors the external interrupt function available on the PTE4 pin. It also disables/enables the pullup resistor on the $\overline{\text{IRQ}}$ pin.

- Controls pullup option on $\overline{\text{IRQ}}$ pin
- Enables PTE4 pin for external interrupts to IRQ
- Shows the state of the PTE4 interrupt flag

Address: \$001C

	Bit 7	6	5	4	3	2	1	Bit 0
Read:	0	0	0	0	0	PTE4IF	PTE4IE	IRQPD
Write:								
Reset:	0	0	0	0	0	0	0	0

 = Unimplemented

Figure 13-4. IRQ Option Control Register (IOCR)

PTE4IF — PTE4 Interrupt Flag

This read-only status bit is high when a falling edge on PTE4 pin is detected. PTE4IF bit clears when the IOCR is read.

- 1 = Falling edge on PTE4 is detected and PTE4IE is set
- 0 = Falling edge on PTE4 is not detected or PTE4IE is clear

PTE4IE — PTE4 Interrupt Enable

This read/write bit enables or disables the interrupt function on the PTE4 pin to trigger the IRQ interrupt. Setting the PTE4IE bit and clearing the USBEN bit in the USB address register configure the PTE4 pin for interrupt function to the IRQ interrupt. Setting PTE4IE also enables the internal pullup on PTE4 pin.

- 1 = PTE4 interrupt enabled; triggers IRQ interrupt
- 0 = PTE4 interrupt disabled

IRQPD — $\overline{\text{IRQ}}$ Pullup Disable

This read/write bit controls the pullup option for the $\overline{\text{IRQ}}$ pin.

1 = Internal pullup is disconnected

0 = Internal pull-up is connected between $\overline{\text{IRQ}}$ pin and V_{DD}

Section 14. Keyboard Interrupt Module (KBI)

14.1 Contents

14.2	Introduction	227
14.3	Features	228
14.4	Pin Name Conventions	228
14.5	Functional Description	230
14.6	Keyboard Initialization	231
14.7	Low-Power Modes	232
14.7.1	Wait Mode	232
14.7.2	Stop Mode	232
14.8	Keyboard Module During Break Interrupts	233
14.9	I/O Registers	233
14.9.1	Keyboard Status and Control Register	233
14.9.2	Keyboard Interrupt Enable Register	235

14.2 Introduction

The keyboard interrupt module (KBI) provides eight independently maskable external interrupts which are accessible via PTA0–PTA7 pins.

14.3 Features

Features of the keyboard interrupt module include:

- Eight keyboard interrupt pins with separate keyboard interrupt enable bits and one keyboard interrupt mask
- Hysteresis buffers
- Programmable edge-only or edge- and level-interrupt sensitivity
- Exit from low-power modes

14.4 Pin Name Conventions

The KBI share eight I/O pins with eight port A I/O pins. The full name of the I/O pins are listed in [Table 14-1](#). The generic pin name appear in the text that follows.

Table 14-1. KBI Pin Name Conventions

Full KBI Pin Names:	KBI Generic Pin Names:
PTA7/ $\overline{\text{KBA7}}$	$\overline{\text{KBA7}}$
PTA7/ $\overline{\text{KBA6}}$	$\overline{\text{KBA6}}$
PTA7/ $\overline{\text{KBA5}}$	$\overline{\text{KBA5}}$
PTA7/ $\overline{\text{KBA4}}$	$\overline{\text{KBA4}}$
PTA7/ $\overline{\text{KBA3}}$	$\overline{\text{KBA3}}$
PTA7/ $\overline{\text{KBA2}}$	$\overline{\text{KBA2}}$
PTA7/ $\overline{\text{KBA1}}$	$\overline{\text{KBA1}}$
PTA7/ $\overline{\text{KBA0}}$	$\overline{\text{KBA0}}$

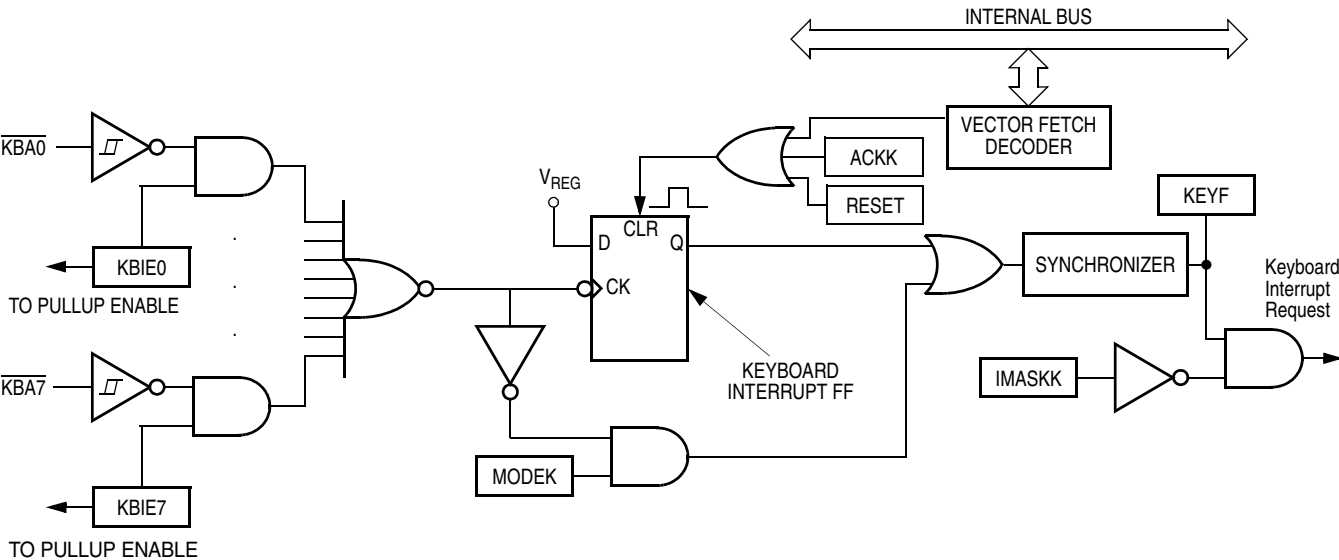

Figure 14-1. Keyboard Module Block Diagram

Table 14-2. I/O Register Summary

Addr.	Register Name		Bit 7	6	5	4	3	2	1	Bit 0
\$0016	Keyboard Status and Control Register (KBSCR)	Read:	0	0	0	0	KEYF	0	IMASKK	MODEK
		Write:						ACKK		
		Reset:	0	0	0	0	0	0	0	0
\$0017	Keyboard Interrupt Enable Register (KBIER)	Read:	KBIE7	KBIE6	KBIE5	KBIE4	KBIE3	KBIE2	KBIE1	KBIE0
		Write:	KBIE7	KBIE6	KBIE5	KBIE4	KBIE3	KBIE2	KBIE1	KBIE0
		Reset:	0	0	0	0	0	0	0	0

= Unimplemented

14.5 Functional Description

Writing to the KBIE7–KBIE0 bits in the keyboard interrupt enable register independently enables or disables each port A pin as a keyboard interrupt pin. Enabling a keyboard interrupt pin also enables its internal pullup device. A logic 0 applied to an enabled keyboard interrupt pin latches a keyboard interrupt request.

A keyboard interrupt is latched when one or more keyboard pins goes low after all were high. The MODEK bit in the keyboard status and control register controls the triggering mode of the keyboard interrupt.

- If the keyboard interrupt is edge-sensitive only, a falling edge on a keyboard pin does not latch an interrupt request if another keyboard pin is already low.
- If the keyboard interrupt is falling edge- and low level-sensitive, an interrupt request is present as long as any keyboard pin is low.

NOTE: *To prevent losing an interrupt request on one pin because another pin is still low, software can disable the latter pin while it is low.*

If the MODEK bit is set, the keyboard interrupt pins are both falling edge- and low level-sensitive, and both of the following actions must occur to clear a keyboard interrupt request:

- Vector fetch or software clear — A vector fetch generates an interrupt acknowledge signal to clear the interrupt request. Software may generate the interrupt acknowledge signal by writing a logic 1 to the ACKK bit in the keyboard status and control register (KBSCR). The ACKK bit is useful in applications that poll the keyboard interrupt pins and require software to clear the keyboard interrupt request. Writing to the ACKK bit prior to leaving an interrupt service routine also can prevent spurious interrupts due to noise. Setting ACKK does not affect subsequent transitions on the keyboard interrupt pins. A falling edge that occurs after writing to the ACKK bit latches another interrupt request. If the keyboard interrupt mask bit, IMASKK, is clear, the CPU loads the program counter with the vector address at locations \$FFF0 and \$FFF1.

- Return of all enabled keyboard interrupt pins to logic 1 — As long as any enabled keyboard interrupt pin is at logic 0, the keyboard interrupt remains set.

The vector fetch or software clear and the return of all enabled keyboard interrupt pins to logic 1 may occur in any order.

If the MODEK bit is clear, the keyboard interrupt pin is falling-edge-sensitive only. With MODEK clear, a vector fetch or software clear immediately clears the keyboard interrupt request.

Reset clears the keyboard interrupt request and the MODEK bit, clearing the interrupt request even if a keyboard interrupt pin stays at logic 0.

The keyboard flag bit (KEYF) in the keyboard status and control register can be used to see if a pending interrupt exists. The KEYF bit is not affected by the keyboard interrupt mask bit (IMASKK) which makes it useful in applications where polling is preferred.

To determine the logic level on a keyboard interrupt pin, use the data direction register to configure the pin as an input and read the data register.

NOTE: *Setting a keyboard interrupt enable bit (KBIE_x) forces the corresponding keyboard interrupt pin to be an input, overriding the data direction register. However, the data direction register bit must be a logic 0 for software to read the pin.*

14.6 Keyboard Initialization

When a keyboard interrupt pin is enabled, it takes time for the pullup device to reach a logic 1. Therefore, a false interrupt can occur as soon as the pin is enabled.

To prevent a false interrupt on keyboard initialization:

1. Mask keyboard interrupts by setting the IMASKK bit in the keyboard status and control register.
2. Enable the KBI pins by setting the appropriate KBIE_x bits in the keyboard interrupt enable register.

3. Write to the ACKK bit in the keyboard status and control register to clear any false interrupts.
4. Clear the IMASKK bit.

An interrupt signal on an edge-triggered pin can be acknowledged immediately after enabling the pin. An interrupt signal on an edge- and level-triggered interrupt pin must be acknowledged after a delay that depends on the external load.

Another way to avoid a false interrupt:

1. Configure the keyboard pins as outputs by setting the appropriate DDRA bits in data direction register A.
2. Write logic 1s to the appropriate port A data register bits.
3. Enable the KBI pins by setting the appropriate KBIE bits in the keyboard interrupt enable register.

14.7 Low-Power Modes

The WAIT and STOP instructions put the MCU in low-power consumption standby modes.

14.7.1 Wait Mode

The keyboard module remains active in wait mode. Clearing the IMASKK bit in the keyboard status and control register enables keyboard interrupt requests to bring the MCU out of wait mode.

14.7.2 Stop Mode

The keyboard module remains active in stop mode. Clearing the IMASKK bit in the keyboard status and control register enables keyboard interrupt requests to bring the MCU out of stop mode.

14.8 Keyboard Module During Break Interrupts

The system integration module (SIM) controls whether the keyboard interrupt latch can be cleared during the break state. The BCFE bit in the break flag control register (BFCR) enables software to clear status bits during the break state.

To allow software to clear the keyboard interrupt latch during a break interrupt, write a logic 1 to the BCFE bit. If a latch is cleared during the break state, it remains cleared when the MCU exits the break state.

To protect the latch during the break state, write a logic 0 to the BCFE bit. With BCFE at logic 0 (its default state), writing to the keyboard acknowledge bit (ACKK) in the keyboard status and control register during the break state has no effect. (See [14.9.1 Keyboard Status and Control Register](#).)

14.9 I/O Registers

These registers control and monitor operation of the keyboard module:

- Keyboard status and control register (KBSCR)
- Keyboard interrupt enable register (KBIER)

14.9.1 Keyboard Status and Control Register

The keyboard status and control register:

- Flags keyboard interrupt requests
- Acknowledges keyboard interrupt requests
- Masks keyboard interrupt requests
- Controls keyboard interrupt triggering sensitivity

Address: \$0016

	Bit 7	6	5	4	3	2	1	Bit 0
Read:	0	0	0	0	KEYF	0	IMASKK	MODEK
Write:						ACKK		
Reset:	0	0	0	0	0	0	0	0

= Unimplemented

Figure 14-2. Keyboard Status and Control Register (KBSCR)

Bits 7–4 — Not used

These read-only bits always read as logic 0s.

KEYF — Keyboard Flag Bit

This read-only bit is set when a keyboard interrupt is pending. Reset clears the KEYF bit.

1 = Keyboard interrupt pending

0 = No keyboard interrupt pending

ACKK — Keyboard Acknowledge Bit

Writing a logic 1 to this write-only bit clears the keyboard interrupt request. ACKK always reads as logic 0. Reset clears ACKK.

IMASKK — Keyboard Interrupt Mask Bit

Writing a logic 1 to this read/write bit prevents the output of the keyboard interrupt mask from generating interrupt requests. Reset clears the IMASKK bit.

1 = Keyboard interrupt requests masked

0 = Keyboard interrupt requests not masked

MODEK — Keyboard Triggering Sensitivity Bit

This read/write bit controls the triggering sensitivity of the keyboard interrupt pins. Reset clears MODEK.

1 = Keyboard interrupt requests on falling edges and low levels

0 = Keyboard interrupt requests on falling edges only

14.9.2 Keyboard Interrupt Enable Register

The keyboard interrupt enable register enables or disables each port A pin to operate as a keyboard interrupt pin.

Address: \$0017

	Bit 7	6	5	4	3	2	1	Bit 0
Read:	KBIE7	KBIE6	KBIE5	KBIE4	KBIE3	KBIE2	KBIE1	KBIE0
Write:								
Reset:	0	0	0	0	0	0	0	0

Figure 14-3. Keyboard Interrupt Enable Register (KBIER)

KBIE7–KBIE0 — Keyboard Interrupt Enable Bits

Each of these read/write bits enables the corresponding keyboard interrupt pin to latch interrupt requests. Reset clears the keyboard interrupt enable register.

1 = PTAx pin enabled as keyboard interrupt pin

0 = PTAx pin not enabled as keyboard interrupt pin



Keyboard Interrupt Module (KBI)

Section 15. Computer Operating Properly (COP)

15.1 Contents

15.2	Introduction	237
15.3	Functional Description	238
15.4	I/O Signals	239
15.4.1	OSCCLK	239
15.4.2	STOP Instruction	239
15.4.3	COPCTL Write	239
15.4.4	Power-On Reset	240
15.4.5	Internal Reset	240
15.4.6	Reset Vector Fetch	240
15.4.7	COPD (COP Disable)	240
15.4.8	COPRS (COP Rate Select)	240
15.5	COP Control Register	241
15.6	Interrupts	241
15.7	Monitor Mode	241
15.8	Low-Power Modes	242
15.8.1	Wait Mode	242
15.8.2	Stop Mode	242
15.9	COP Module During Break Mode	242

15.2 Introduction

The computer operating properly (COP) module contains a free-running counter that generates a reset if allowed to overflow. The COP module helps software recover from runaway code. Prevent a COP reset by clearing the COP counter periodically. The COP module can be disabled through the COPD bit in the CONFIG register.

15.3 Functional Description

Figure 15-1 shows the structure of the COP module.

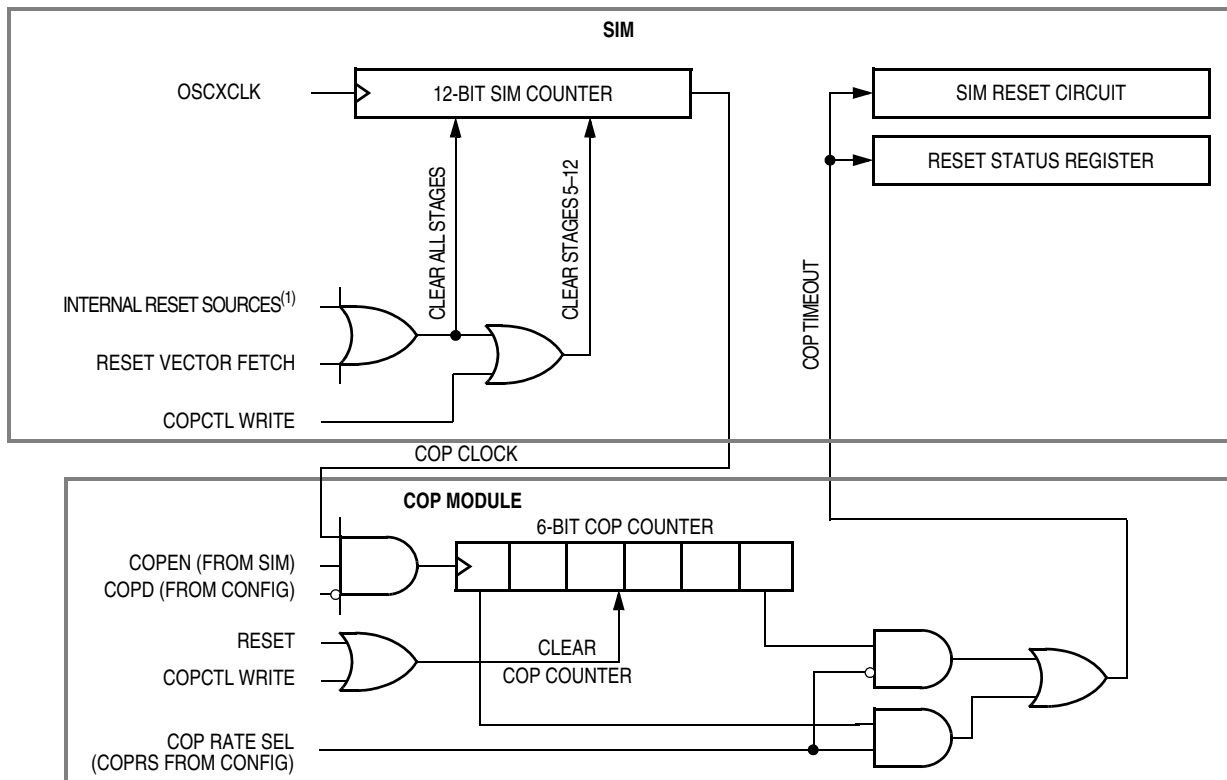

NOTE:

1. See SIM section for more details.

Figure 15-1. COP Block Diagram

The COP counter is a free-running 6-bit counter preceded by a 12-bit system integration module (SIM) counter. If not cleared by software, the COP counter overflows and generates an asynchronous reset after $2^{18} - 2^4$ or $2^{13} - 2^4$ OSCXCLK cycles, depending on the state of the COP rate select bit, COPRS in the configuration register. With a $2^{18} - 2^4$ OSCXCLK cycle overflow option (COPRS = 0), a 12MHz OSCXCLK clock (6MHz crystal) gives a COP timeout period of 21.84 ms. Writing any value to location \$FFFF before an overflow occurs prevents a COP reset by clearing the COP counter and stages 12 through 5 of the SIM counter.

NOTE: *Service the COP immediately after reset and before entering or after exiting stop mode to guarantee the maximum time before the first COP counter overflow.*

A COP reset pulls the $\overline{\text{RST}}$ pin low for 32 OSCXCLK cycles and sets the COP bit in the reset status register (RSR).

In monitor mode, the COP is disabled if the $\overline{\text{RST}}$ pin or the $\overline{\text{IRQ}}$ is held at $V_{\text{DD}} + V_{\text{HI}}$. During the break state, $V_{\text{DD}} + V_{\text{HI}}$ on the $\overline{\text{RST}}$ pin disables the COP.

NOTE: *Place COP clearing instructions in the main program and not in an interrupt subroutine. Such an interrupt subroutine could keep the COP from generating a reset even while the main program is not working properly.*

15.4 I/O Signals

The following paragraphs describe the signals shown in [Figure 15-1](#).

15.4.1 OSCXCLK

OSCXCLK is the clock doubler output signal. OSCXCLK frequency is double of the crystal frequency.

15.4.2 STOP Instruction

The STOP instruction clears the COP prescaler.

15.4.3 COPCTL Write

Writing any value to the COP control register (COPCTL) (see [15.5 COP Control Register](#)) clears the COP counter and clears bits 12 through 5 of the SIM counter. Reading the COP control register returns the low byte of the reset vector.

15.4.4 Power-On Reset

The power-on reset (POR) circuit in the SIM clears the COP prescaler 4096 OSCXCLK cycles after power-up.

15.4.5 Internal Reset

An internal reset clears the SIM counter and the COP counter.

15.4.6 Reset Vector Fetch

A reset vector fetch occurs when the vector address appears on the data bus. A reset vector fetch clears the COP prescaler.

15.4.7 COPD (COP Disable)

The COPD signal reflects the state of the COP disable bit (COPD) in the configuration register (CONFIG).

15.4.8 COPRS (COP Rate Select)

The COPRS signal reflects the state of the COP rate select bit (COPRS) in the configuration register (CONFIG).

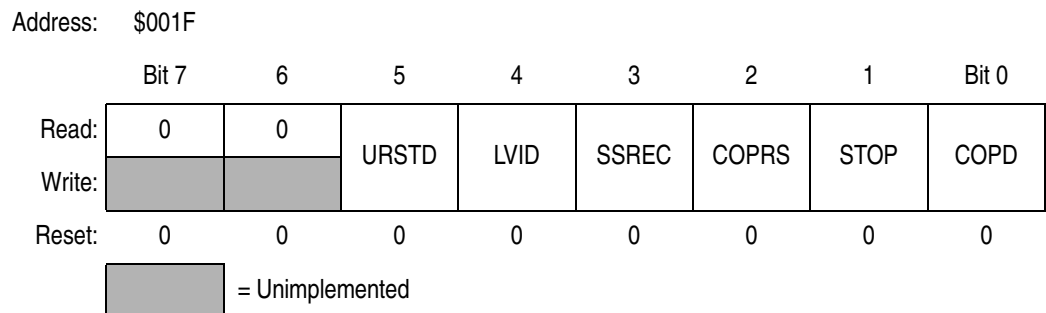

Figure 15-2. Configuration Register (CONFIG)

COPRS — COP Rate Select Bit

COPRS selects the COP timeout period. Reset clears COPRS.

1 = COP timeout period is $(2^{13} - 2^4) \times \text{OSCXOUT}$ cycles

0 = COP timeout period is $(2^{18} - 2^4) \times \text{OSCXOUT}$ cycles

COPD — COP Disable Bit

COPD disables the COP module.

1 = COP module disabled

0 = COP module enabled

15.5 COP Control Register

The COP control register is located at address \$FFFF and overlaps the reset vector. Writing any value to \$FFFF clears the COP counter and starts a new timeout period. Reading location \$FFFF returns the low byte of the reset vector.

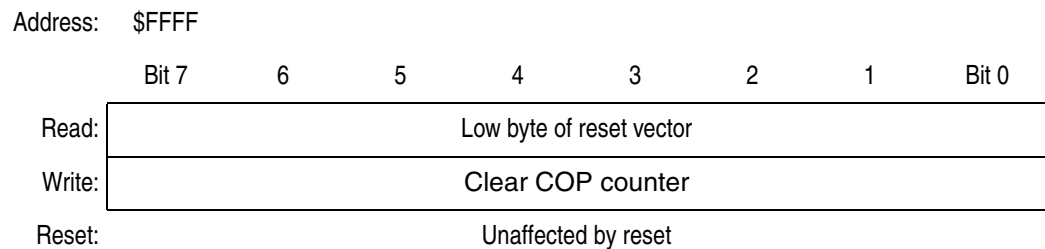

Figure 15-3. COP Control Register (COPCTL)

15.6 Interrupts

The COP does not generate CPU interrupt requests.

15.7 Monitor Mode

The COP is disabled in monitor mode when $V_{DD} + V_{HI}$ is present on the $\overline{\text{IRQ}}$ pin or on the $\overline{\text{RST}}$ pin.

15.8 Low-Power Modes

The WAIT and STOP instructions put the MCU in low-power consumption standby modes.

15.8.1 Wait Mode

The COP remains active during wait mode. To prevent a COP reset during wait mode, periodically clear the COP counter in a CPU interrupt routine.

15.8.2 Stop Mode

Stop mode turns off the OSCXCLK input to the COP and clears the COP prescaler. Service the COP immediately before entering or after exiting stop mode to ensure a full COP timeout period after entering or exiting stop mode.

The STOP bit in the configuration register (CONFIG) enables the STOP instruction. To prevent inadvertently turning off the COP with a STOP instruction, disable the STOP instruction by clearing the STOP bit.

15.9 COP Module During Break Mode

The COP is disabled during a break interrupt when $V_{DD} + V_{HI}$ is present on the \overline{RST} pin.

Section 16. Low Voltage Inhibit (LVI)

16.1 Contents

16.2	Introduction	243
16.3	Functional Description	243
16.4	LVI Control Register (CONFIG)	244
16.5	Low-Power Modes	244
16.5.1	Wait Mode	244
16.5.2	Stop Mode	244

16.2 Introduction

This section describes the low-voltage inhibit module (LVI), which monitors the voltage on the V_{DD} pin and generates a reset when the V_{DD} voltage falls to the LVI trip (V_{LVR}) voltage.

16.3 Functional Description

Figure 16-1 shows the structure of the LVI module. The LVI is enabled after a reset. The LVI module contains a bandgap reference circuit and comparator. Setting LVI disable bit (LVID) disables the LVI to monitor V_{DD} voltage.

The LVI module generates one output signal:

LVI Reset — an reset signal will be generated to reset the CPU when V_{DD} drops to below the set trip point.

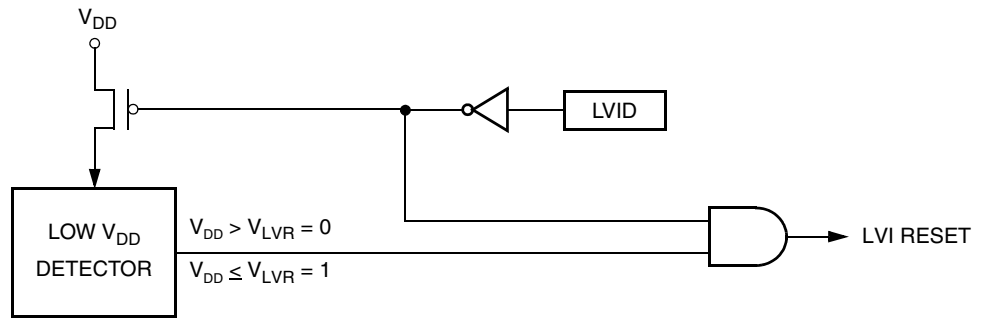

Figure 16-1. LVI Module Block Diagram

16.4 LVI Control Register (CONFIG)

Address: \$001F

	Bit 7	6	5	4	3	2	1	Bit 0
Read:	0	0	URSTD	LVID	SSREC	COPRS	STOP	COPD
Write:								
Reset:	0	0	0	0	0	0	0	0

One-time writable register after each reset. URSTD and LVID bits are reset by POR or LVI reset only.

= Unimplemented

Figure 16-2. Configuration Register (CONFIG)

LVID —pLow Voltage Inhibit Disable Bit
 1 = Low voltage inhibit disabled
 0 = Low voltage inhibit enabled

16.5 Low-Power Modes

The STOP and WAIT instructions put the MCU in low-power consumption standby modes.

16.5.1 Wait Mode

The LVI module, when enabled, will continue to operate in WAIT Mode.

16.5.2 Stop Mode

The LVI module, when enabled, will continue to operate in STOP Mode.

Section 17. Break Module (BREAK)

17.1 Contents

17.2	Introduction	245
17.3	Features	246
17.4	Functional Description	246
17.4.1	Flag Protection During Break Interrupts	248
17.4.2	CPU During Break Interrupts	248
17.4.3	TIM During Break Interrupts	248
17.4.4	COP During Break Interrupts	248
17.5	Low-Power Modes	248
17.5.1	Wait Mode	248
17.5.2	Stop Mode	249
17.6	Break Module Registers	249
17.6.1	Break Status and Control Register	249
17.6.2	Break Address Registers	250
17.6.3	Break Status Register	250
17.6.4	Break Flag Control Register (BFCR)	252

17.2 Introduction

This section describes the break module. The break module can generate a break interrupt that stops normal program flow at a defined address to enter a background program.

17.3 Features

Features of the break module include the following:

- Accessible i/o registers during the break interrupt
- CPU-generated break interrupts
- Software-generated break interrupts
- COP disabling during break interrupts

17.4 Functional Description

When the internal address bus matches the value written in the break address registers, the break module issues a breakpoint signal ($\overline{\text{BKPT}}$) to the SIM. The SIM then causes the CPU to load the instruction register with a software interrupt instruction (SWI) after completion of the current CPU instruction. The program counter vectors to \$FFFC and \$FFFD (\$FEFC and \$FEFD in monitor mode).

These events can cause a break interrupt to occur:

- A CPU-generated address (the address in the program counter) matches the contents of the break address registers.
- Software writes a logic 1 to the BRKA bit in the break status and control register.

When a CPU-generated address matches the contents of the break address registers, the break interrupt begins after the CPU completes its current instruction. A return-from-interrupt instruction (RTI) in the break routine ends the break interrupt and returns the MCU to normal operation. [Figure 17-1](#) shows the structure of the break module.

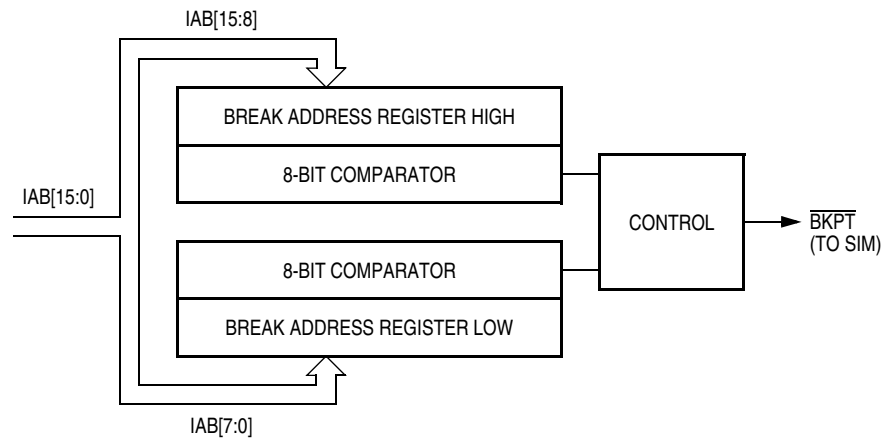

Figure 17-1. Break Module Block Diagram

Addr.	Register Name		Bit 7	6	5	4	3	2	1	Bit 0
\$FE00	Break Status Register (BSR)	Read:	R	R	R	R	R	R	SBSW	R
		Write:							See note	
		Reset:	0							
\$FE03	Break Flag Control Register (BFCR)	Read:	BCFE	R	R	R	R	R	R	R
		Write:								
		Reset:	0							
\$FE0C	Break Address High Register (BRKH)	Read:	Bit15	Bit14	Bit13	Bit12	Bit11	Bit10	Bit9	Bit8
		Write:								
		Reset:	0	0	0	0	0	0	0	0
\$FE0D	Break Address low Register (BRKL)	Read:	Bit7	Bit6	Bit5	Bit4	Bit3	Bit2	Bit1	Bit0
		Write:								
		Reset:	0	0	0	0	0	0	0	0
\$FE0E	Break Status and Control Register (BRKSCR)	Read:	BRKE	BRKA	0	0	0	0	0	0
		Write:								
		Reset:	0	0	0	0	0	0	0	0

Note: Writing a logic 0 clears SBSW.

= Unimplemented
 R = Reserved

Figure 17-2. Break I/O Register Summary

17.4.1 Flag Protection During Break Interrupts

The BCFC bit in the break flag control register (BFCCR) enables software to clear status bits during the break state.

17.4.2 CPU During Break Interrupts

The CPU starts a break interrupt by:

- Loading the instruction register with the SWI instruction
- Loading the program counter with \$FFFC and \$FFFD (\$FEFC and \$FEFD in monitor mode)

The break interrupt begins after completion of the CPU instruction in progress. If the break address register match occurs on the last cycle of a CPU instruction, the break interrupt begins immediately.

17.4.3 TIM During Break Interrupts

A break interrupt stops the timer counter.

17.4.4 COP During Break Interrupts

The COP is disabled during a break interrupt when $V_{REG} + V_{HI}$ is present on the \overline{RST} pin.

17.5 Low-Power Modes

The WAIT and STOP instructions put the MCU in low-power-consumption standby modes.

17.5.1 Wait Mode

If enabled, the break module is active in wait mode. In the break routine, the user can subtract one from the return address on the stack if SBSW is set (see [8.7 Low-Power Modes](#)). Clear the SBSW bit by writing logic 0 to it.

17.5.2 Stop Mode

A break interrupt causes exit from stop mode and sets the SBSW bit in the break status register. See [8.8 SIM Registers](#).

17.6 Break Module Registers

These registers control and monitor operation of the break module:

- Break status and control register (BRKSCR)
- Break address register high (BRKH)
- Break address register low (BRKL)
- Break status register (BSR)
- Break flag control register (BFCR)

17.6.1 Break Status and Control Register

The break status and control register contains break module enable and status bits.

Address: \$FE0E

	Bit 7	6	5	4	3	2	1	Bit 0
Read:	BRKE	BRKA	0	0	0	0	0	0
Write:								
Reset:	0	0	0	0	0	0	0	0

= Unimplemented

Figure 17-3. Break Status and Control Register (BRKSCR)

BRKE — Break Enable Bit

This read/write bit enables breaks on break address register matches. Clear BRKE by writing a logic 0 to bit 7. Reset clears the BRKE bit.

- 1 = Breaks enabled on 16-bit address match
- 0 = Breaks disabled

BRKA — Break Active Bit

This read/write status and control bit is set when a break address match occurs. Writing a logic 1 to BRKA generates a break interrupt. Clear BRKA by writing a logic 0 to it before exiting the break routine. Reset clears the BRKA bit.

- 1 = Break address match
- 0 = No break address match

17.6.2 Break Address Registers

The break address registers contain the high and low bytes of the desired breakpoint address. Reset clears the break address registers.

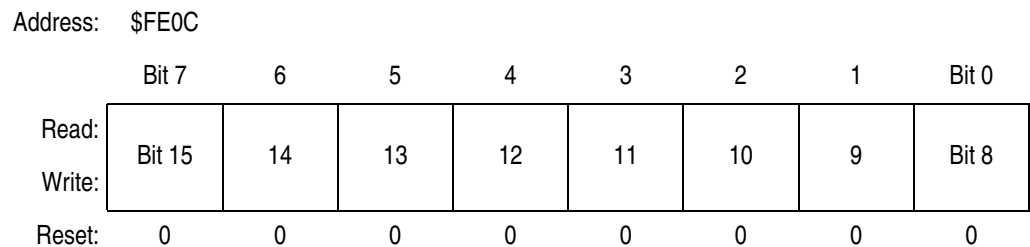

Figure 17-4. Break Address Register High (BRKH)

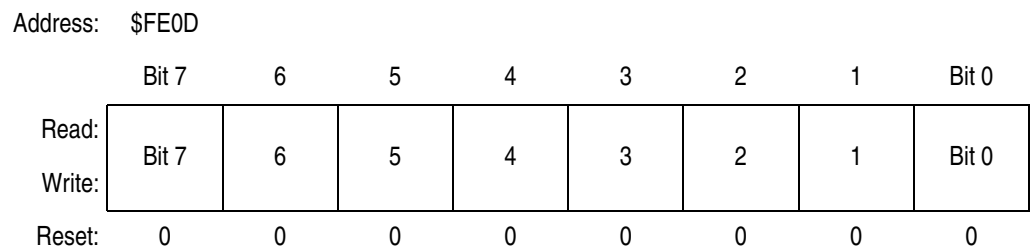

Figure 17-5. Break Address Register Low (BRKL)

17.6.3 Break Status Register

The break status register (BSR) contains a flag to indicate that a break caused an exit from stop or wait mode. This status bit is useful in applications requiring a return to wait or stop mode after exiting from a break interrupt.

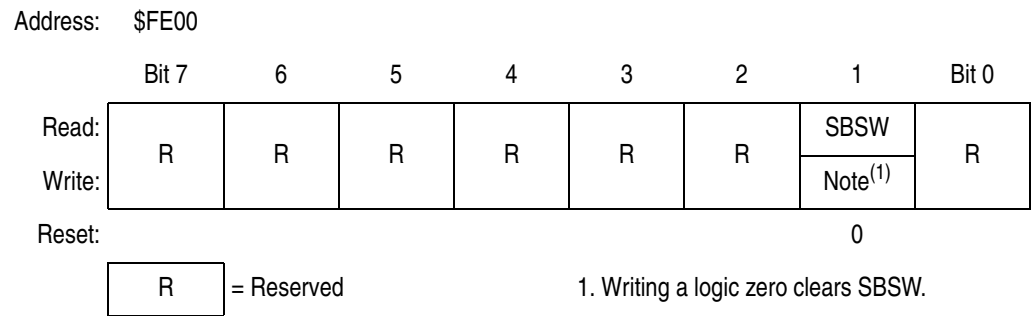

Figure 17-6. Break Status Register (BSR)

SBSW — SIM Break Stop/Wait

This read/write bit is set when a break interrupt causes an exit from wait or stop mode. Clear SBSW by writing a logic 0 to it. Reset clears SBSW.

- 1 = Stop mode or wait mode was exited by break interrupt
- 0 = Stop mode or wait mode was not exited by break interrupt

SBSW can be read within the break state SWI routine. The user can modify the return address on the stack by subtracting one from it. The following code is an example of this.

This code works if the H register was stacked in the break interrupt routine. Execute this code at the end of the break interrupt routine.

```

HIBYTE EQU 5
LOBYTE EQU 6
;      If not SBSW, do RTI
      BRCLR SBSW,BSR, RETURN ; See if wait mode or stop mode
                                ; was exited by break.
      TST LOBYTE,SP           ; If RETURNLO is not zero,
      BNE DOLO                ; then just decrement low byte.
      DEC HIBYTE,SP          ; Else deal with high byte, too.
DOLO DEC LOBYTE,SP           ; Point to WAIT/STOP opcode.
RETURN PULH                  ; Restore H register.
      RTI
    
```

17.6.4 Break Flag Control Register (BFCR)

The break control register contains a bit that enables software to clear status bits while the MCU is in a break state.

Address: \$FE03

	Bit 7	6	5	4	3	2	1	Bit 0
Read:	BCFE	R	R	R	R	R	R	R
Write:								
Reset:	0							

R

 = Reserved

Figure 17-7. Break Flag Control Register High (BFCR)

BCFE — Break Clear Flag Enable Bit

This read/write bit enables software to clear status bits by accessing status registers while the MCU is in a break state. To clear status bits during the break state, the BCFE bit must be set.

1 = Status bits clearable during break

0 = Status bits not clearable during break

Section 18. Electrical Specifications

18.1 Contents

18.2	Introduction	253
18.3	Absolute Maximum Ratings	254
18.4	Functional Operating Range.	255
18.5	Thermal Characteristics	255
18.6	DC Electrical Characteristics	256
18.7	Control Timing	257
18.8	Oscillator Characteristics	257
18.9	USB DC Electrical Characteristics	258
18.10	USB Low-Speed Source Electrical Characteristics	259
18.11	USB Signaling Levels	260
18.12	Timer Interface Module Characteristics	260
18.13	Memory Characteristics	261

18.2 Introduction

This section contains electrical and timing specifications.

18.3 Absolute Maximum Ratings

Maximum ratings are the extreme limits to which the MCU can be exposed without permanently damaging it.

NOTE: *This device is not guaranteed to operate properly at the maximum ratings. Refer to [18.6 DC Electrical Characteristics](#) for guaranteed operating conditions.*

Characteristic ⁽¹⁾	Symbol	Value	Unit
Supply voltage	V_{DD}	-0.3 to +6.0	V
Input voltage PTE4/D-, PTE3/D+ \overline{RST} , \overline{IRQ} Others	V_{IN}	$V_{SS} - 1.0$ to $V_{DD} + 0.3$ $V_{SS} - 0.3$ to $V_{DD} + 0.3$ $V_{SS} - 0.3$ to $V_{REG} + 0.3$	V
Mode entry voltage, \overline{IRQ} pin	$V_{DD} + V_{HI}$	$V_{SS} - 0.3$ to +11	V
Maximum current per pin excluding V_{DD} and V_{SS}	I	± 25	mA
Storage temperature	T_{STG}	-55 to +150	°C
Maximum current of PTD0/1 (20-pin package)	I_{OL}	-25 to +50	mA
Maximum current out of V_{SS}	I_{MVSS}	100	mA
Maximum current into V_{DD}	I_{MVDD}	100	mA

NOTES:

1. Voltages referenced to V_{SS}

NOTE: *This device contains circuitry to protect the inputs against damage due to high static voltages or electric fields; however, it is advised that normal precautions be taken to avoid application of any voltage higher than maximum-rated voltages to this high-impedance circuit. For proper operation, it is recommended that V_{IN} and V_{OUT} be constrained to the range $V_{SS} \leq (V_{IN} \text{ or } V_{OUT}) \leq V_{REG}$. Reliability of operation is enhanced if unused inputs are connected to an appropriate logic voltage level (for example, either V_{SS} or V_{REG}).*

18.4 Functional Operating Range

Characteristic	Symbol	Value	Unit
Operating temperature range	T_A	0 to 70	°C
Operating voltage range	V_{DD}	4.0 to 5.5	V

18.5 Thermal Characteristics

Characteristic	Symbol	Value	Unit
Thermal Resistance QFP (44 pins) SOIC (28 pins) SOIC (20 pins) PDIP (20 pins)	θ_{JA}	95 70 70 70	°C/W
I/O pin power dissipation	$P_{I/O}$	User determined	W
Power dissipation ⁽¹⁾	P_D	$P_D = (I_{DD} \times V_{DD}) + P_{I/O} =$ $K/(T_J + 273 \text{ }^\circ\text{C})$	W
Constant ⁽²⁾	K	$P_D \times (T_A + 273 \text{ }^\circ\text{C})$ $+ P_D^2 \times \theta_{JA}$	W/°C
Average junction temperature	T_J	$T_A + (P_D \times \theta_{JA})$	°C
Maximum junction temperature	T_{JM}	100	°C

NOTES:

- Power dissipation is a function of temperature.
- K is a constant unique to the device. K can be determined for a known T_A and measured P_D . With this value of K, P_D and T_J can be determined for any value of T_A .

18.6 DC Electrical Characteristics

Characteristic ⁽¹⁾	Symbol	Min	Typ ⁽²⁾	Max	Unit
Regulator output voltage	V_{REG}	3.0	3.3	3.6	V
Output high voltage ($I_{Load} = -2.0$ mA) PTA0–PTA7, PTB0–PTB7, PTC0–PTC7, PTE0–PTE2	V_{OH}	$V_{REG} - 0.8$	—	—	V
Output low voltage ($I_{Load} = 1.6$ mA) All I/O pins ($I_{Load} = 25$ mA) PTD0–PTD1 in ILDD mode ($I_{Load} = 10$ mA) PTE3–PTE4 with USB disabled	V_{OL}	— — —	— — —	0.4 0.5 0.4	V
Input high voltage All ports, OSC1 IRQ, RST	V_{IH}	$0.7 \times V_{REG}$ $0.7 \times V_{DD}$	— —	V_{REG} V_{DD}	V
Input low voltage All ports, OSC1 IRQ, RST	V_{IL}	V_{SS} V_{SS}	— —	$0.3 \times V_{REG}$ $0.3 \times V_{DD}$	V
Output low current ($V_{OL} = 2.0$ V) PTD2–PTD5 in LDD mode	I_{OL}	10	13	20	mA
V_{DD} supply current, $V_{DD} = 5.25$ V, $f_{OP} = 3$ MHz					
Run, with low speed USB ⁽³⁾		—	5.0	7.5	mA
Run, with USB suspended ⁽³⁾		—	4.5	6.5	mA
Wait, with low speed USB ⁽⁴⁾	I_{DD}	—	3.0	5.0	mA
Wait, with USB suspended ⁽⁴⁾		—	2.5	4.0	mA
Stop ⁽⁵⁾ 0 °C to 70 °C		—	300	350	μA
I/O ports Hi-Z leakage current	I_{IL}	—	—	± 10	μA
Input current	I_{IN}	—	—	± 1	μA
Capacitance Ports (as input or output)	C_{Out} C_{In}	— —	— —	12 8	pF
POR re-arm voltage ⁽⁶⁾	V_{POR}	0	—	100	mV
POR rise-time ramp rate ⁽⁷⁾	R_{POR}	0.035	—	—	V/ms
Monitor mode entry voltage	$V_{DD} + V_{HI}$	$1.4 \times V_{DD}$	—	$2 \times V_{DD}$	V
Pullup resistors Port A, port B, port C, PTE0–PTE2, \overline{RST} , \overline{IRQ} PTE3–PTE4 (with USB module disabled) D– (with USB module enabled)	R_{PU}	25 4 1.2	40 5 1.5	55 6 2	kΩ
LVI reset	V_{LVR}	2.8	3.3	3.8	V

NOTES:

1. $V_{DD} = 4.0$ to 5.5 Vdc, $V_{SS} = 0$ Vdc, $T_A = T_L$ to T_H , unless otherwise noted.
2. Typical values reflect average measurements at midpoint of voltage range, 25 °C only.
3. Run (operating) I_{DD} measured using external square wave clock source ($f_{XCLK} = 6$ MHz). All inputs 0.2 V from rail. No dc loads. Less than 100 pF on all outputs. $C_L = 20$ pF on OSC2. All ports configured as inputs. OSC2 capacitance linearly affects run I_{DD} . Measured with all modules enabled.
4. Wait I_{DD} measured using external square wave clock source ($f_{XCLK} = 6$ MHz); all inputs 0.2 V from rail; no dc loads; less than 100 pF on all outputs. $C_L = 20$ pF on OSC2; 15 k $\Omega \pm 5\%$ termination resistors on D+ and D– pins; all ports configured as inputs; OSC2 capacitance linearly affects wait I_{DD} .
5. STOP I_{DD} measured with USB in suspend mode; OSC1 grounded; transceiver pullup resistor of 1.5 k $\Omega \pm 5\%$ between V_{REG} and D– and 15 k $\Omega \pm 5\%$ termination resistors on D+ and D– pins; no port pins sourcing current.
6. Maximum is highest voltage that POR is guaranteed.
7. If minimum V_{REG} is not reached before the internal POR reset is released, \overline{RST} must be driven low externally until minimum V_{REG} is reached.

18.7 Control Timing

Characteristic ⁽¹⁾	Symbol	Min	Max	Unit
Internal operating frequency ⁽²⁾	f_{OP}	—	3	MHz
\overline{RST} input pulse width low ⁽³⁾	t_{IRL}	125	—	ns

NOTES:

1. $V_{DD} = 4.0$ to 5.5 Vdc; $V_{SS} = 0$ Vdc; timing shown with respect to 20% V_{DD} and 70% V_{DD} , unless otherwise noted.
2. Some modules may require a minimum frequency greater than dc for proper operation; see appropriate table for this information.
3. Minimum pulse width reset is guaranteed to be recognized. It is possible for a smaller pulse width to cause a reset.

18.8 Oscillator Characteristics

Characteristic	Symbol	Min	Typ	Max	Unit
Crystal frequency ⁽¹⁾	f_{XCLK}	1	—	6	MHz
External clock Reference frequency ^{(1), (2)}	f_{XCLK}	dc	—	6	MHz
Crystal load capacitance ⁽³⁾	C_L	—	—	—	
Crystal fixed capacitance ⁽³⁾	C_1	—	$2 \times C_L$	—	
Crystal tuning capacitance ⁽³⁾	C_2	—	$2 \times C_L$	—	
Feedback bias resistor	R_B	—	10 M Ω	—	
Series resistor ^{(3), (4)}	R_S	—	—	—	

NOTES:

1. The USB module is designed to function at $f_{XCLK} = 6$ MHz.
2. No more than 10% duty cycle deviation from 50% .
3. Consult crystal vendor data sheet.
4. Not required for high-frequency crystals.

18.9 USB DC Electrical Characteristics

Characteristic ⁽¹⁾	Symbol	Conditions	Min	Typ	Max	Unit
Hi-Z state data line leakage	I_{LO}	$0\text{ V} < V_{IN} < 3.3\text{ V}$	-10		+10	μA
Voltage input high (driven)	V_{IH}		2.0			V
Voltage input high (floating)	V_{IHZ}		2.7		3.6	V
Voltage input low	V_{IL}				0.8	V
Differential input sensitivity	V_{DI}	$ I(D+) - (D-) $	0.2			V
Differential common mode range	V_{CM}	Includes V_{DI} Range	0.8		2.5	V
Static output low	V_{OL}	R_L of 1.425 K to 3.6 V			0.3	V
Static output high	V_{OH}	R_L of 14.25 K to GND	2.8		3.6	V
Output signal crossover voltage	V_{CRS}		1.3	—	2.0	V
Regulator bypass capacitor	$C_{REGBYPASS}$			0.1		μF
Regulator bulk capacitor	$C_{REGBULK}$		4.7			μF

NOTES:

- $V_{DD} = 4.0$ to 5.5 Vdc, $V_{SS} = 0$ Vdc, $T_A = T_L$ to T_H , unless otherwise noted.

18.10 USB Low-Speed Source Electrical Characteristics

Characteristic ⁽¹⁾	Symbol	Conditions	Min	Typ	Max	Unit
Internal operating frequency	f_{OP}	—	—	3	—	MHz
Transition time ⁽²⁾						
Rise time	t_R	$C_L = 200\text{ pF}$	75	—	300	ns
Fall time	t_F	$C_L = 600\text{ pF}$ $C_L = 200\text{ pF}$ $C_L = 600\text{ pF}$	75	—	300	ns
Rise/Fall time matching	t_{RFM}	t_R/t_F	80	—	120	%
Low speed data rate	t_{DRATE}	1.5 Mbs \pm 1.5%	1.4775 676.8	1.500 666.0	1.5225 656.8	Mbs ns
Source differential driver jitter To next transition For paired transitions	t_{DDJ1} t_{DDJ2}	$C_L = 600\text{ pF}$ Measured at crossover point	-25 -10	— —	25 10	ns
Receiver data jitter tolerance To next transition For paired transitions	t_{DJR1} t_{DJR2}	$C_L = 600\text{ pF}$ Measured at crossover point	-75 -45	— —	75 45	ns
Source SEO interval of EOP	t_{LEOPT}	Measured at crossover point	1.25	—	1.50	μs
Source jitter for differential transition to SEO transition ⁽³⁾		Measured at crossover point		667		ns
Receiver SEO interval of EOP Must reject as EOP Must accept	t_{LEOPR1} t_{LEOPR2}	Measured at crossover point	210 670	— —	— —	ns
Width of SEO interval during differential transition	t_{LST}	Measured at crossover point	—	—	210	ns

NOTES:

1. All voltages are measured from local ground, unless otherwise specified. All timings use a capacitive load of 50 pF, unless otherwise specified. Low-speed timings have a 1.5k Ω pullup to 2.8 V on the D- data line.
2. Transition times are measured from 10% to 90% of the data signal. The rising and falling edges should be smoothly transitioning (monotonic). Capacitive loading includes 50 pF of tester capacitance.
3. The two transitions are a (nominal) bit time apart.

18.11 USB Signaling Levels

Bus State	Signaling Levels	
	Transmit	Receive
Differential 1	$D+ > V_{OH} \text{ (min) and } D- < V_{OL} \text{ (max)}$	$(D+) - (D-) > 200 \text{ mV}$
Differential 0	$D- > V_{OH} \text{ (min) and } D+ < V_{OL} \text{ (max)}$	$(D-) - (D+) > 200 \text{ mV}$
Single-ended 0 (SE0)	$D+ \text{ and } D- < V_{OL} \text{ (max)}$	$D+ \text{ and } D- < V_{IL} \text{ (max)}$
Data J state (low speed)	Differential 0	Differential 0
Data K state (low speed)	Differential 1	Differential 1
Idle state (low speed)	NA	$D- > V_{IHZ} \text{ (min) and } D+ < V_{IL} \text{ (max)}$
Resume state	Differential 1	Differential 1
Start of packet (SOP)	Data lines switch from Idle to K State	
End of packet (EOP)	SE0 for approximately 2 bit times ⁽¹⁾ followed by a J state for 1 bit time	SE0 for ≥ 1 bit time ⁽²⁾ followed by a J state for 1 bit time
Reset	NA	$D+ \text{ and } D- < V_{IL} \text{ (max) for } \geq 8\mu\text{s}$

NOTES:

1. The width of EOP is defined in bit times relative to the speed of transmission.
2. The width of EOP is defined in bit times relative to the device type receiving the EOP. The bit time is approximate.

18.12 Timer Interface Module Characteristics

Characteristic	Symbol	Min	Max	Unit
Input capture pulse width	t_{TIH}, t_{TIL}	$1/f_{OP}$	—	
Input clock pulse width	t_{TCH}, t_{TCL}	$(1/f_{OP}) + 5\text{ns}$	—	

18.13 Memory Characteristics

Characteristic	Symbol	Min	Max	Unit
RAM data retention voltage	V_{RDR}	1.3	—	V
FLASH block size	—	512		Bytes
FLASH programming size	—	64		Bytes
FLASH read bus clock frequency	$f_{Read}^{(1)}$	32 k	8.4 M	Hz
FLASH block erase time	$t_{Erase}^{(2)}$	2	—	ms
FLASH mass erase time	$t_{MErase}^{(3)}$	2	—	ms
FLASH PGM/ERASE to HVEN set up time	t_{nvs}	5	—	μ S
FLASH high-voltage hold time	t_{nvh}	5	—	μ S
FLASH high-voltage hold time (mass erase)	t_{nvhl}	100	—	μ S
FLASH program hold time	t_{pgs}	10	—	μ S
FLASH program time	t_{PROG}	20	—	μ S
FLASH return to read time	$t_{rcv}^{(4)}$	1	—	μ S
FLASH cumulative program hv period	$t_{HV}^{(5)}$	—	25	ms
FLASH row erase endurance ⁽⁶⁾	—	10k	—	Cycles
FLASH row program endurance ⁽⁷⁾	—	10k	—	Cycles
FLASH data retention time ⁽⁸⁾	—	10	—	Years

NOTES:

- f_{READ} is defined as the frequency range for which the FLASH memory can be read.
- If the page erase time is longer than t_{Erase} (Min), there is no erase-disturb, but it reduced the endurance of the flash memory
- If the mass erase time is longer than t_{MErase} (Min), there is no erase-disturb, but it reduced the endurance of the flash memory
- t_{rcv} is defined as the time it need before start the read of the flash after turn off the HVEN bit
- t_{HV} is defined as the cumulative high voltage programming time to the same row before next erase
- The minimum row endurance value specifies each row of the FLASH memory is guaranteed to work for at least this many erase / program cycles.
- The minimum row endurance value specifies each row of the FLASH memory is guaranteed to work for at least this many erase / program cycles.
- The FLASH is guaranteed to retain data over the entire operating temperature range for at least the minimum time specified.



Section 19. Mechanical Specifications

19.1 Contents

19.2	Introduction	263
19.3	44-Pin Plastic Quad Flat Pack (QFP)	264
19.4	28-Pin Small Outline Integrated Circuit (SOIC)	265
19.5	20-Pin Dual In-Line Package (PDIP)	265
19.6	20-Pin Small Outline Integrated Circuit (SOIC)	266

19.2 Introduction

This section gives the dimensions for:

- 44-pin plastic quad flat pack (case 824A)
- 28-pin small outline integrated circuit package (case 751F)
- 20-pin plastic dual in-line package (case 738)
- 20-pin small outline integrated circuit package (case 751D)

19.3 44-Pin Plastic Quad Flat Pack (QFP)

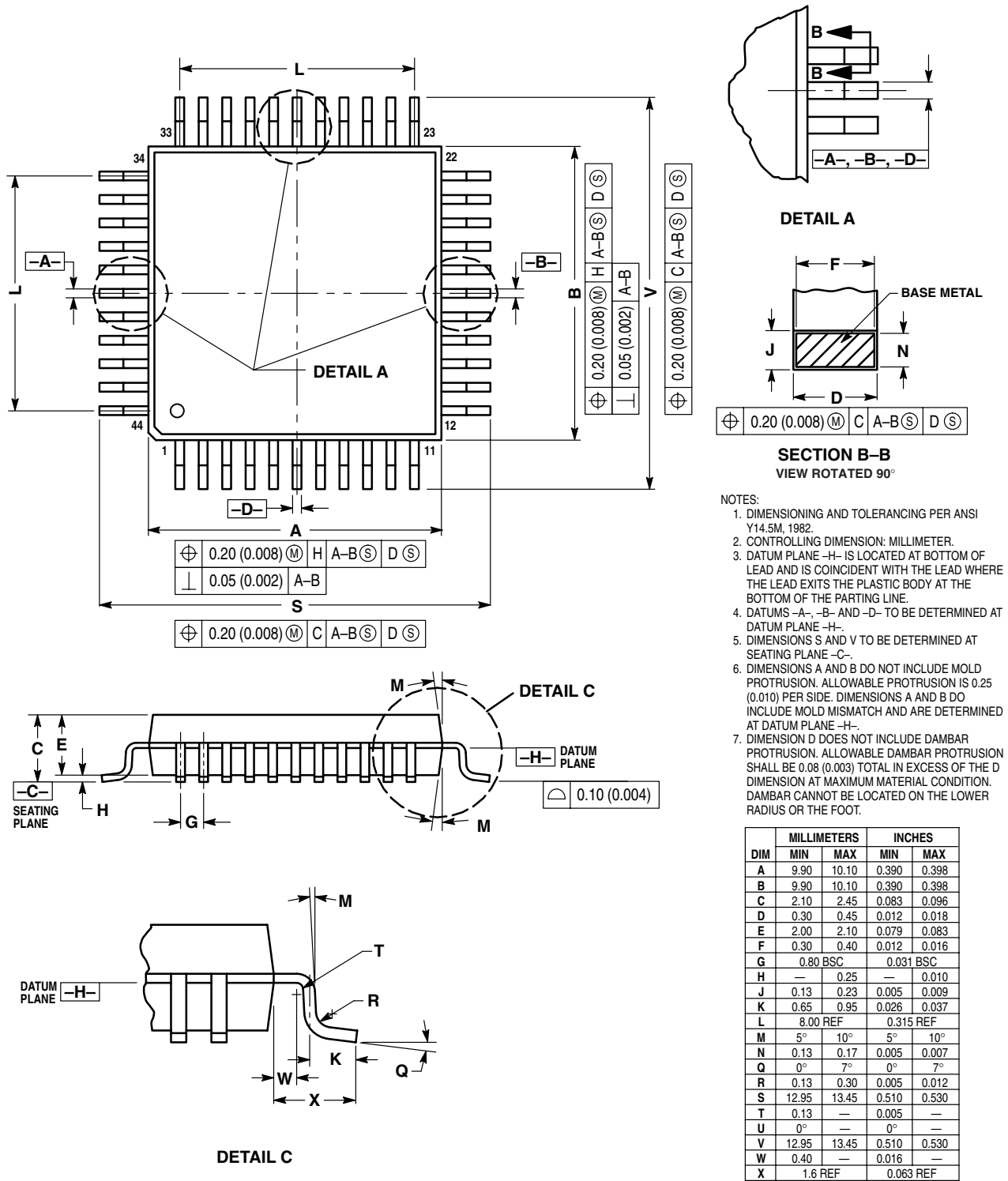

Figure 19-1. 44-Pin QFP (Case 824A)

19.4 28-Pin Small Outline Integrated Circuit (SOIC)

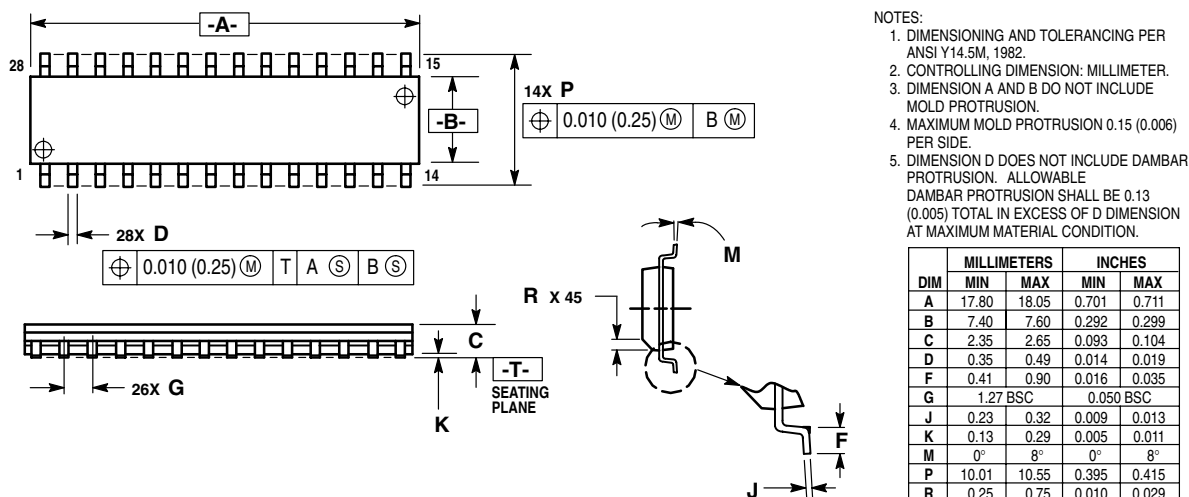

Figure 19-2. 28-Pin SOIC (Case 751F)

19.5 20-Pin Dual In-Line Package (PDIP)

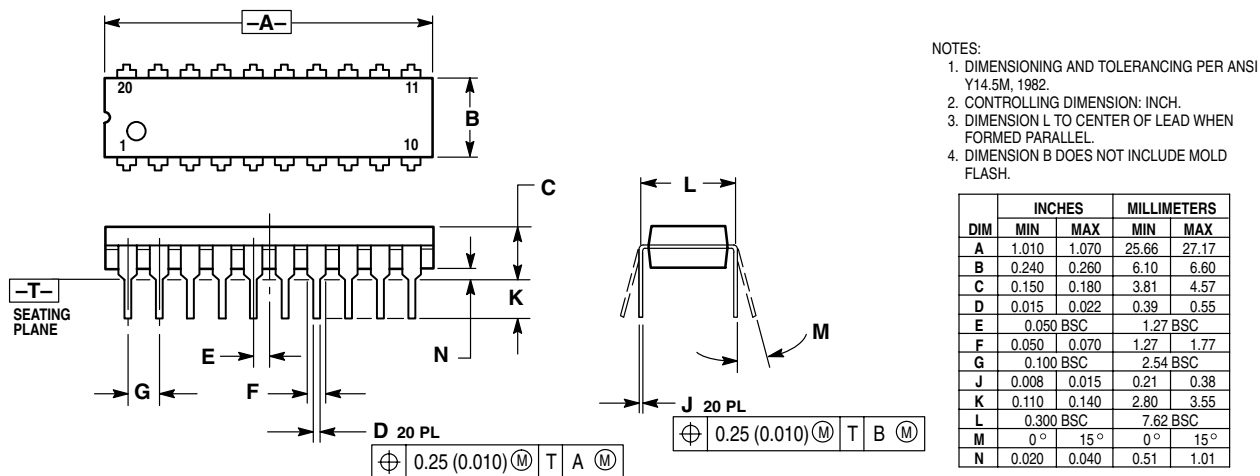

Figure 19-3. 20-Pin PDIP (Case 738)

19.6 20-Pin Small Outline Integrated Circuit (SOIC)

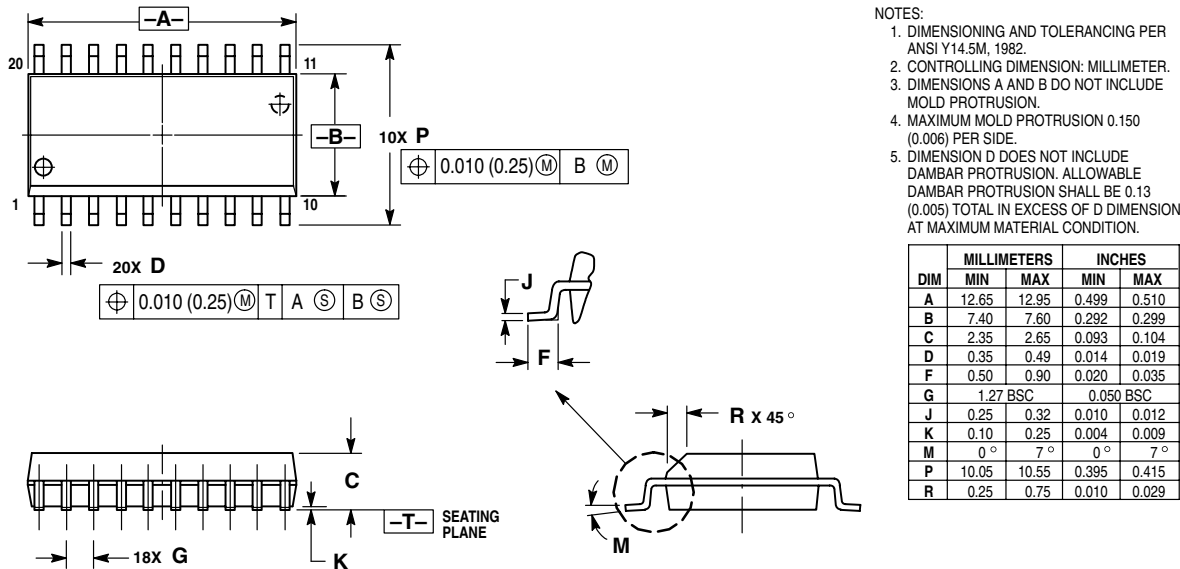

Figure 19-4. 20-Pin SOIC (Case 751D)

Section 20. Ordering Information

20.1 Contents

20.2	Introduction	267
20.3	MC Order Numbers	267

20.2 Introduction

This section contains ordering numbers for the MC68HC908JB8.

20.3 MC Order Numbers

Table 20-1. MC Order Numbers

MC Order Number	Package	Operating Temperature Range	Compliance
MC68HC908JB8JP	20-pin PDIP	0 to +70 °C	—
MC68HC908JB8JDW	20-pin SOIC	0 to +70 °C	
MC68HC908JB8ADW	28-pin SOIC	0 to +70 °C	
MC68HC908JB8FB	44-pin QFP	0 to +70 °C	
MC68HC908JB8JPE	20-pin PDIP	0 to +70 °C	Pb-Free and RoHS compliant.
MC908JB8JDWE	20-pin SOIC	0 to +70 °C	
MC908JB8ADWE	28-pin SOIC	0 to +70 °C	
MC908JB8FBE	44-pin QFP	0 to +70 °C	



Ordering Information



Appendix A. MC68HC08JB8

A.1 Contents

A.2	Introduction	270
A.3	MCU Block Diagram	270
A.4	Memory Map	270
A.5	Reserved Registers	273
A.6	Monitor ROM	273
A.7	Electrical Specifications	273
A.7.1	DC Electrical Characteristics	274
A.7.2	Memory Characteristics	275
A.8	MC68HC08JB8 Order Numbers	275

A.2 Introduction

This section introduces the MC68HC08JB8, the ROM part equivalent to the MC68HC908JB8. The entire data book apply to this ROM device, with exceptions outlined in this appendix.

Table A-1. Summary of MC68HC08JB8 and MC68HC908JB8 Differences

	MC68HC08JB8	MC68HC908JB8
Memory (\$DC00–\$FBFF)	8,192 bytes ROM	8,192 bytes FLASH
User vectors (\$FFF0–\$FFFF)	16 bytes ROM	16 bytes FLASH
Registers at \$FE08 and \$FF09	Not used; locations are reserved.	FLASH related registers. \$FE08 — FLCR \$FF09 — FLBPR
Monitor ROM (\$FC00–\$FDFF and \$FE10–\$FFDF)	\$FC00–\$FDFF: Not used. \$FE10–\$FFDF: Used for testing purposes only.	Used for testing and FLASH programming/erasing.

A.3 MCU Block Diagram

Figure A-1 shows the block diagram of the MC68HC08JB8.

A.4 Memory Map

The MC68HC08JB8 has 8,192 bytes of user ROM from \$DC00 to \$FBFF, and 16 bytes of user ROM vectors from \$FFF0 to \$FFFF. On the MC68HC908JB8, these memory locations are FLASH memory.

Figure A-2 shows the memory map of the MC68HC08JB8.

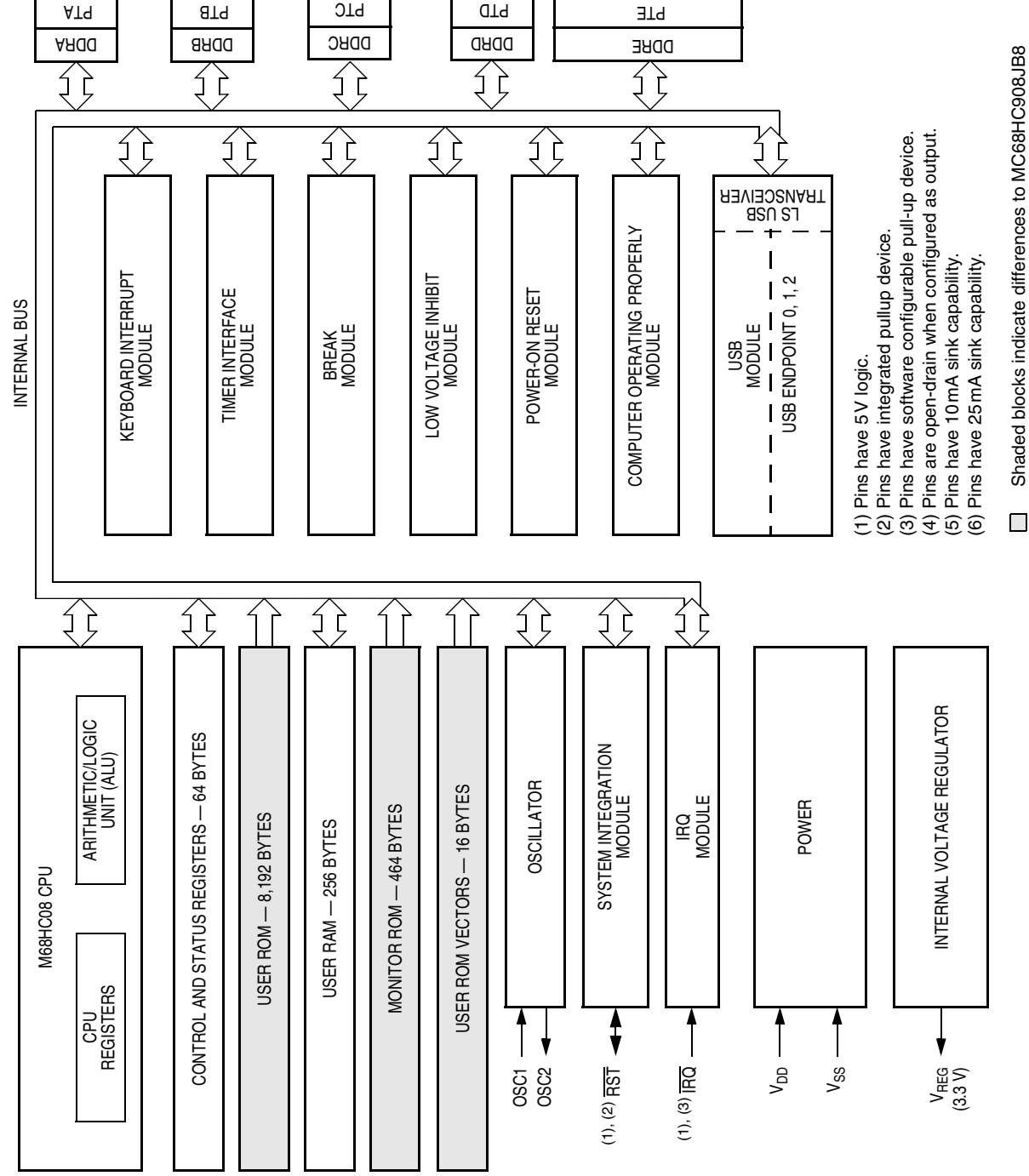

Figure A-1. MC68HC08JB8 Block Diagram

\$0000 ↓ \$003F	I/O Registers 64 Bytes
\$0040 ↓ \$013F	RAM 256 Bytes
\$0140 ↓ \$DBFF	Unimplemented 56,000 Bytes
\$DC00 ↓ \$FBFF	ROM 8,192 Bytes
\$FC00 ↓ \$FDFF	Unimplemented 512 Bytes
\$FE00	Break Status Register (BSR)
\$FE01	Reset Status Register (RSR)
\$FE02	Reserved
\$FE03	Break Flag Control Register (BFCR)
\$FE04	Interrupt Status Register 1 (INT1)
\$FE05	Reserved
\$FE06	Reserved
\$FE07	Reserved
\$FE08	Reserved
\$FE09	Reserved
\$FE0A	Reserved
\$FE0B	Reserved
\$FE0C	Break Address High Register (BRKH)
\$FE0D	Break Address Low Register (BRKL)
\$FE0E	Break Status and Control Register (BRKSCR)
\$FE0F	Reserved
\$FE10 ↓ \$FFDF	Monitor ROM 464 Bytes
\$FFE0 ↓ \$FFEF	Reserved 16 Bytes
\$FFF0 ↓ \$FFFF	ROM Vectors 16 Bytes

Figure A-2. MC68HC08JB8 Memory Map

A.5 Reserved Registers

The two registers at \$FE08 and \$FE09 are reserved locations on the MC68HC08JB8.

On the MC68HC908JB8, these two locations are the FLASH control register and the FLASH block protect register respectively.

A.6 Monitor ROM

The monitor program (monitor ROM: \$FE10–\$FFDF) on the MC68HC08JB8 is for device testing only. \$FC00–\$FDFF are unused.

A.7 Electrical Specifications

Electrical specifications for the MC68HC908JB8 apply to the MC68HC08JB8, except for the parameters indicated below.

A.7.1 DC Electrical Characteristics

Characteristic ⁽¹⁾	Symbol	Min	Typ ⁽²⁾	Max	Unit
Regulator output voltage	V_{REG}	3.0	3.3	3.6	V
Output high voltage ($I_{Load} = -2.0$ mA) PTA0–PTA7, PTB0–PTB7, PTC0–PTC7, PTE0–PTE2	V_{OH}	$V_{REG} - 0.8$	—	—	V
Output low voltage ($I_{Load} = 1.6$ mA) All I/O pins ($I_{Load} = 25$ mA) PTD0–PTD1 in ILDD mode ($I_{Load} = 10$ mA) PTE3–PTE4 with USB disabled	V_{OL}	— — —	— — —	0.4 0.5 0.4	V
Input high voltage All ports, OSC1 \overline{IRQ} , \overline{RST}	V_{IH}	$0.7 \times V_{REG}$ $0.7 \times V_{DD}$	— —	V_{REG} V_{DD}	V
Input low voltage All ports, OSC1 \overline{IRQ} , \overline{RST}	V_{IL}	V_{SS} V_{SS}	— —	$0.3 \times V_{REG}$ $0.3 \times V_{DD}$	V
Output low current ($V_{OL} = 2.0$ V) PTD2–PTD5 in LDD mode	I_{OL}	17	22	27	mA
V_{DD} supply current, $V_{DD} = 5.25$ V, $f_{OP} = 3$ MHz					
Run, with low speed USB ⁽³⁾	I_{DD}	—	5.0	7.5	mA
Run, with USB suspended ⁽³⁾		—	4.5	6.5	mA
Wait, with low speed USB ⁽⁴⁾		—	3.0	5.0	mA
Wait, with USB suspended ⁽⁴⁾		—	2.5	4.0	mA
Stop ⁽⁵⁾ 0 °C to 70°C		—	30	100	μA
I/O ports Hi-Z leakage current	I_{IL}	—	—	± 10	μA
Input current	I_{IN}	—	—	± 1	μA
Capacitance Ports (as input or output)	C_{Out} C_{In}	— —	— —	12 8	pF
POR re-arm voltage ⁽⁶⁾	V_{POR}	0	—	100	mV
POR rise-time ramp rate ⁽⁷⁾	R_{POR}	0.035	—	—	V/ms
Monitor mode entry voltage	$V_{DD} + V_{HI}$	$1.4 \times V_{DD}$		$2 \times V_{DD}$	V
Pullup resistors Port A, port B, port C, PTE0–PTE2, \overline{RST} , \overline{IRQ} PTE3–PTE4 (with USB module disabled) D– (with USB module enabled)	R_{PU}	25 4 1.2	40 5 1.5	55 6 2.0	kΩ
LVI reset	V_{LVR}	2.4	2.7	3.0	V

NOTES:

1. $V_{DD} = 4.0$ to 5.5 Vdc, $V_{SS} = 0$ Vdc, $T_A = T_L$ to T_H , unless otherwise noted.
2. Typical values reflect average measurements at midpoint of voltage range, 25 °C only.
3. Run (operating) I_{DD} measured using external square wave clock source ($f_{XCLK} = 6$ MHz). All inputs 0.2 V from rail. No dc loads. Less than 100 pF on all outputs. $C_L = 20$ pF on OSC2. All ports configured as inputs. OSC2 capacitance linearly affects run I_{DD} . Measured with all modules enabled.
4. Wait I_{DD} measured using external square wave clock source ($f_{XCLK} = 6$ MHz); all inputs 0.2 V from rail; no dc loads; less than 100 pF on all outputs. $C_L = 20$ pF on OSC2; 15 k $\Omega \pm 5\%$ termination resistors on D+ and D- pins; all ports configured as inputs; OSC2 capacitance linearly affects wait I_{DD} .
5. STOP I_{DD} measured with USB in suspend mode; OSC1 grounded; transceiver pullup resistor of 1.5 k $\Omega \pm 5\%$ between V_{REG} and D- pins and 15 k $\Omega \pm 5\%$ termination resistor on D+ pin; no port pins sourcing current.
6. Maximum is highest voltage that POR is guaranteed.
7. If minimum V_{REG} is not reached before the internal POR reset is released, \overline{RST} must be driven low externally until minimum V_{REG} is reached.

A.7.2 Memory Characteristics

Characteristic	Symbol	Min	Max	Unit
RAM data retention voltage	V_{RDR}	1.3	—	V

Notes:

Since MC68HC08JB8 is a ROM device, FLASH memory electrical characteristics do not apply.

A.8 MC68HC08JB8 Order Numbers

These part numbers are generic numbers only. To place an order, ROM code must be submitted to the ROM Processing Center (RPC).

Table A-2. MC68HC08JB8 Order Numbers

MC Order Number	Package	Operating Temperature Range
MC68HC08JB8JP	20-pin PDIP	0 to +70 °C
MC68HC08JB8JDW	20-pin SOIC	0 to +70 °C
MC68HC08JB8ADW	28-pin SOIC	0 to +70 °C
MC68HC08JB8FB	44-pin QFP	0 to +70 °C



Appendix B. MC68HC08JT8

B.1 Contents

B.2	Introduction	278
B.3	MCU Block Diagram	278
B.4	Memory Map	278
B.5	Power Supply Pins	281
B.6	Reserved Register Bit	281
B.7	Reserved Registers	281
B.8	Monitor ROM	282
B.9	Universal Serial Bus Module	282
B.10	Low-Voltage Inhibit Module	282
B.11	Electrical Specifications	282
B.11.1	Absolute Maximum Ratings	282
B.11.2	Functional Operating Range	283
B.11.3	DC Electrical Characteristics	283
B.11.4	Control Timing	284
B.11.5	Memory Characteristics	284
B.12	MC68HC08JT8 Order Numbers	284

B.2 Introduction

This section introduces the MC68HC08JT8, a low-voltage ROM part version to the MC68HC908JB8. The entire data book apply to this ROM device, with exceptions outlined in this appendix.

Table B-1. Summary of MC68HC08JT8 and MC68HC908JB8 Differences

	MC68HC08JT8	MC68HC908JB8
Memory (\$DC00–\$FBFF)	8,192 bytes ROM	8,192 bytes FLASH
User vectors (\$FFF0–\$FFFF)	16 bytes ROM	16 bytes FLASH
Registers at \$FE08 and \$FF09	Not used; locations are reserved	FLASH related registers. \$FE08 — FLCR \$FF09 — FLBPR
Bit 4 at CONFIG (\$001F)	Not used; bit is reserved.	LVID: low-voltage inhibit disable bit
Monitor ROM (\$FC00–\$FDFF and \$FE10–\$FFDF)	\$FC00–\$FDFF: Not used. \$FE10–\$FFDF: Used for testing purposes only.	Used for testing and FLASH programming/erasing.
Low voltage inhibit module	Not available (disabled)	Available
Universal Serial Bus (USB) module	Not available. User should set the SUSPND bit to logic 1 to reduce power consumption.	Available
On-chip 3.3V regulator	Not available (disabled)	Available
Operating voltage	2.0 to 3.6V	4.0 to 5.5V
Operating frequency	$f_{OPMAX} = 2.5\text{MHz}$ at 2V $f_{OPMAX} = 3\text{MHz}$ at 3V	3MHz

B.3 MCU Block Diagram

Figure B-1 shows the block diagram of the MC68HC08JT8.

B.4 Memory Map

The MC68HC08JT8 has 8,192 bytes of user ROM from \$DC00 to \$FBFF, and 16 bytes of user ROM vectors from \$FFF0 to \$FFFF. On the MC68HC908JB8, these memory locations are FLASH memory.

Figure B-2 shows the memory map of the MC68HC08JT8.

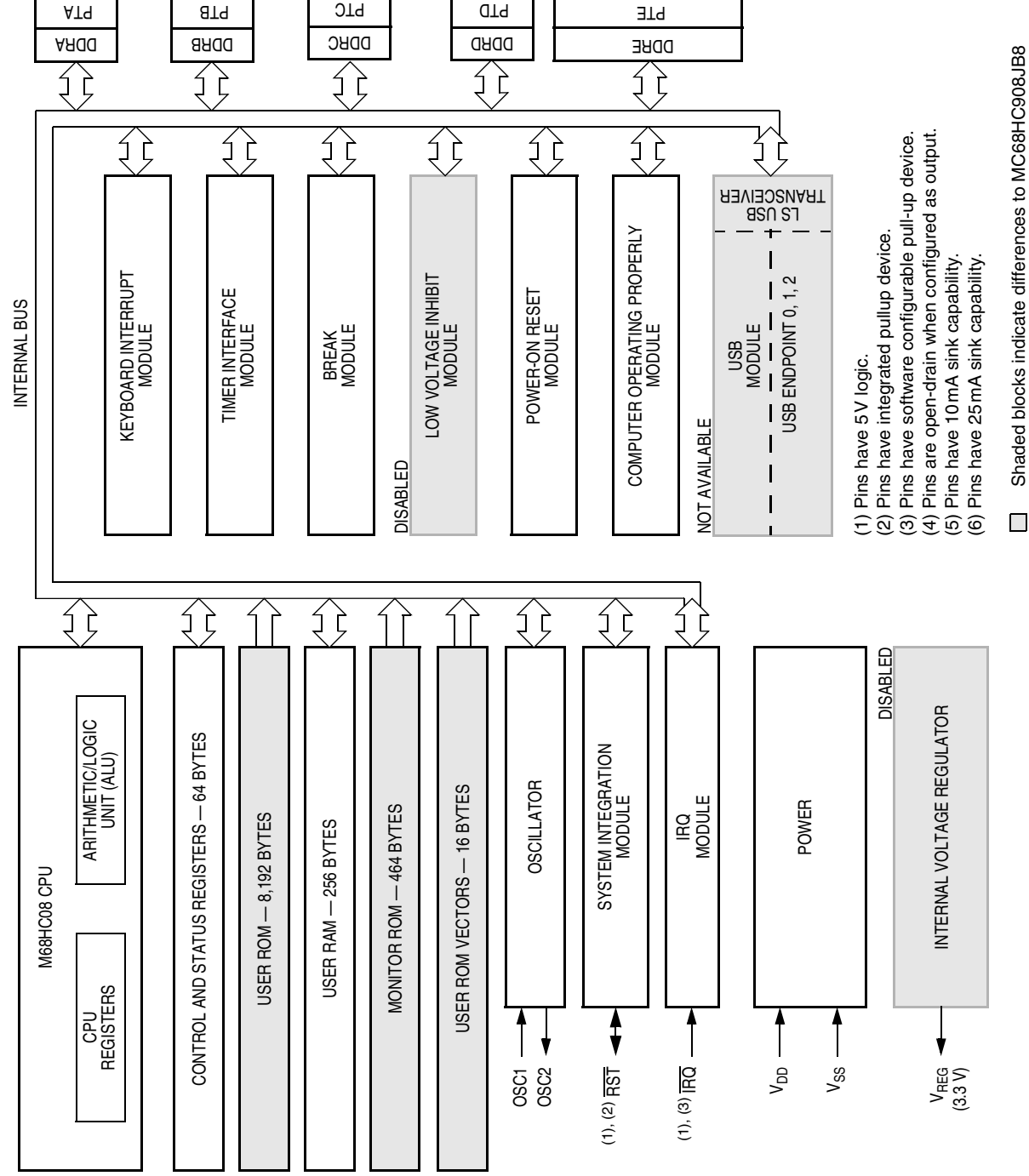

Figure B-1. MC68HC08JT8 Block Diagram

\$0000 ↓ \$003F	I/O Registers 64 Bytes
\$0040 ↓ \$013F	RAM 256 Bytes
\$0140 ↓ \$DBFF	Unimplemented 56,000 Bytes
\$DC00 ↓ \$FBFF	ROM 8,192 Bytes
\$FC00 ↓ \$FDFF	Unimplemented 512 Bytes
\$FE00	Break Status Register (BSR)
\$FE01	Reset Status Register (RSR)
\$FE02	Reserved
\$FE03	Break Flag Control Register (BFCR)
\$FE04	Interrupt Status Register 1 (INT1)
\$FE05	Reserved
\$FE06	Reserved
\$FE07	Reserved
\$FE08	Reserved
\$FE09	Reserved
\$FE0A	Reserved
\$FE0B	Reserved
\$FE0C	Break Address High Register (BRKH)
\$FE0D	Break Address Low Register (BRKL)
\$FE0E	Break Status and Control Register (BRKSCR)
\$FE0F	Reserved
\$FE10 ↓ \$FFDF	Monitor ROM 464 Bytes
\$FFE0 ↓ \$FFEF	Reserved 16 Bytes
\$FFF0 ↓ \$FFFF	ROM Vectors 16 Bytes

Figure B-2. MC68HC08JT8 Memory Map

B.5 Power Supply Pins

The MC68HC08JT8 is design for low voltage operation. Connect V_{DD} and V_{REG} for normal operation.

The V_{REG} voltage regulator is disabled on the MC68HC08JT8.

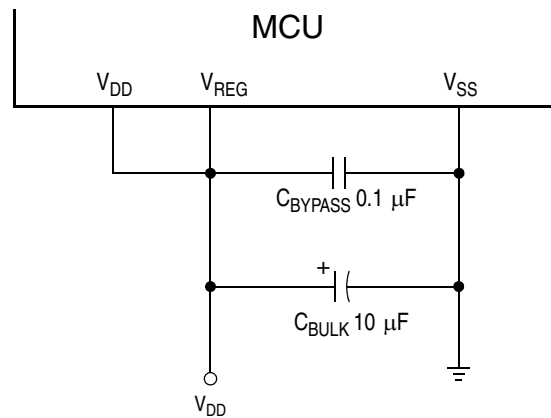

NOTE: Values shown are typical values.

Figure B-3. Power Supply Bypassing

B.6 Reserved Register Bit

Bit 4 of the configuration register ($\$001F$) is a reserved bit on the MC68HC08JT8. The bit will always read as zero.

On the MC68HC908JB8, bit 4 of the configuration register is the low-voltage inhibit disable bit, LVID.

B.7 Reserved Registers

The two registers at $\$FE08$ and $\$FE09$ are reserved locations on the MC68HC08JT8.

On the MC68HC908JB8, these two locations are the FLASH control register and the FLASH block protect register respectively.

B.8 Monitor ROM

The monitor program (monitor ROM: \$FE10–\$FFDF) on the MC68HC08JT8 is for device testing only. \$FC00–\$FDFF are unused.

B.9 Universal Serial Bus Module

The USB module is designed for operation with $V_{DD} = 4V$ to $5.5V$, therefore, it should not be used on the MC68HC08JT8 device. To further reduce current consumption in stop mode, set the SUSPND bit in the USB interrupt register 0 (UIR0) to logic 1. Other USB registers should be left in their default state.

B.10 Low-Voltage Inhibit Module

The LVI module is disabled on the MC68HC08JT8.

B.11 Electrical Specifications

Electrical specifications for the MC68HC908JB8 apply to the MC68HC08JT8, except for the parameters indicated below.

B.11.1 Absolute Maximum Ratings

Characteristic ⁽¹⁾	Symbol	Value	Unit
Supply voltage	V_{DD}	−0.3 to +3.9	V
Input voltage	V_{IN}	$V_{SS} - 0.3$ to $V_{DD} + 0.3$	V
Maximum current per pin excluding V_{DD} and V_{SS}	I	± 25	mA
Storage temperature	T_{STG}	−55 to +150	°C
Maximum current of PTD0/1 (20-pin package)	I_{OL}	−15 to +30	mA
Maximum current out of V_{SS}	I_{MVSS}	100	mA
Maximum current into V_{DD}	I_{MVDD}	100	mA

NOTES:

1. Voltages referenced to V_{SS} .

B.11.2 Functional Operating Range

Characteristic	Symbol	Value	Unit
Operating temperature range	T_A	0 to 70	°C
Operating voltage range	V_{DD}	2.0 to 3.6	V

B.11.3 DC Electrical Characteristics

Characteristic ⁽¹⁾	Symbol	Min	Typ ⁽²⁾	Max	Unit
Output high voltage ($I_{Load} = -1.6$ mA) PTA0–PTA7, PTB0–PTB7, PTC0–PTC7, PTE0–PTE2	V_{OH}	$V_{DD}-0.4$	—	—	V
Output low voltage ($I_{Load} = 1.6$ mA) All I/O pins ($I_{Load} = 15$ mA) PTD0–PTD1 in ILDD mode ($I_{Load} = 5$ mA) PTE3–PTE4	V_{OL}	— — —	— — —	0.4 0.5 0.4	V
Input high voltage All ports, OSC1, \overline{IRQ} , \overline{RST}	V_{IH}	$0.7 \times V_{DD}$	—	V_{DD}	V
Input low voltage All ports, OSC1, \overline{IRQ} , \overline{RST}	V_{IL}	V_{SS}	—	$0.3 \times V_{DD}$	V
Output low current ($V_{OL} = 2.0$ V) ⁽³⁾ PTD2–PTD5 in LDD mode ($V_{DD} = 2$ V) PTD2–PTD5 in LDD mode ($V_{DD} = 3$ V)	I_{OL}	— —	6 16	— —	mA
V_{DD} supply current, $V_{DD} = 3$ V, $f_{OP} = 3$ MHz Run ⁽⁴⁾ Wait ⁽⁵⁾ Stop ⁽⁶⁾ 0 °C to 70°C	I_{DD}	— — —	3.5 2.5 20	6.5 4.5 30	mA mA μ A
I/O ports Hi-Z leakage current	I_{IL}	—	—	± 10	μ A
Input current	I_{IN}	—	—	± 1	μ A
Capacitance Ports (as input or output)	C_{Out} C_{In}	— —	— —	12 8	pF
POR re-arm voltage ⁽⁷⁾	V_{POR}	0	—	100	mV
POR rise-time ramp rate	R_{POR}	0.02	—	—	V/ms
Monitor mode entry voltage	$V_{DD}+V_{HI}$	$1.4 \times V_{DD}$	—	$2 \times V_{DD}$	V
Pullup resistors Port A, port B, port C, PTE0–PTE2, \overline{RST} , \overline{IRQ} PTE3–PTE4	R_{PU}	25 4	40 5	55 6	k Ω k Ω

NOTES:

1. $V_{DD} = 2.0$ to 3.6 Vdc, $V_{SS} = 0$ Vdc, $T_A = T_L$ to T_H , unless otherwise noted.
2. Typical values reflect average measurements at $3V$, $25\text{ }^\circ\text{C}$ only.
3. In LDD mode, the specified I_{OL} is achieved when the external pullup voltage is equal to or higher than the voltage: $V_{OL} +$ voltage dropped across LED.
4. Run (operating) I_{DD} measured using external square wave clock source ($f_{XCLK} = 6$ MHz). All inputs 0.2 V from rail. No dc loads. Less than 100 pF on all outputs. $C_L = 20$ pF on OSC2. All ports configured as inputs. OSC2 capacitance linearly affects run I_{DD} . Measured with all modules enabled.
5. Wait I_{DD} measured using external square wave clock source ($f_{XCLK} = 6$ MHz). All inputs 0.2 V from rail. No dc loads. Less than 100 pF on all outputs. $C_L = 20$ pF on OSC2. All ports configured as inputs. OSC2 capacitance linearly affects wait I_{DD} .
6. Stop I_{DD} measured with OSC1 grounded; no port pins sourcing current.
7. Maximum is highest voltage that POR is guaranteed.

B.11.4 Control Timing

Characteristic	Symbol	Min	Max	Unit
Internal operating frequency	f_{OP}	—	2.5	MHz
$V_{DD} = 2.0V$		—	3.0	MHz
$V_{DD} = 3.0V$				

B.11.5 Memory Characteristics

Characteristic	Symbol	Min	Max	Unit
RAM data retention voltage	V_{RDR}	1.3	—	V

NOTES: Since MC68HC08JT8 is a ROM device, FLASH memory electrical characteristics do not apply.

B.12 MC68HC08JT8 Order Numbers

These part numbers are generic numbers only. To place an order, ROM code must be submitted to the ROM Processing Center (RPC).

Table B-2. MC68HC08JT8 Order Numbers

MC Order Number	Package	Operating Temperature Range	Compliance
MC68HC08JT8ADW	28-pin SOIC	0 to +70 °C	—
MC68HC08JT8FB	44-pin QFP	0 to +70 °C	
MC68HC08JT8FBE	44-pin QFP	0 to +70 °C	Pb-Free and RoHS compliant.

How to Reach Us:

Home Page:

www.freescale.com

E-mail:

support@freescale.com

USA/Europe or Locations Not Listed:

Freescale Semiconductor
Technical Information Center, CH370
1300 N. Alma School Road
Chandler, Arizona 85224
+1-800-521-6274 or +1-480-768-2130
support@freescale.com

Europe, Middle East, and Africa:

Freescale Halbleiter Deutschland GmbH
Technical Information Center
Schatzbogen 7
81829 Muenchen, Germany
+44 1296 380 456 (English)
+46 8 52200080 (English)
+49 89 92103 559 (German)
+33 1 69 35 48 48 (French)
support@freescale.com

Japan:

Freescale Semiconductor Japan Ltd.
Headquarters
ARCO Tower 15F
1-8-1, Shimo-Meguro, Meguro-ku,
Tokyo 153-0064
Japan
0120 191014 or +81 3 5437 9125
support.japan@freescale.com

Asia/Pacific:

Freescale Semiconductor Hong Kong Ltd.
Technical Information Center
2 Dai King Street
Tai Po Industrial Estate
Tai Po, N.T., Hong Kong
+800 2666 8080
support.asia@freescale.com

For Literature Requests Only:

Freescale Semiconductor Literature Distribution Center
P.O. Box 5405
Denver, Colorado 80217
1-800-441-2447 or 303-675-2140
Fax: 303-675-2150
LDCForFreescaleSemiconductor@hibbertgroup.com

Information in this document is provided solely to enable system and software implementers to use Freescale Semiconductor products. There are no express or implied copyright licenses granted hereunder to design or fabricate any integrated circuits or integrated circuits based on the information in this document.

Freescale Semiconductor reserves the right to make changes without further notice to any products herein. Freescale Semiconductor makes no warranty, representation or guarantee regarding the suitability of its products for any particular purpose, nor does Freescale Semiconductor assume any liability arising out of the application or use of any product or circuit, and specifically disclaims any and all liability, including without limitation consequential or incidental damages. "Typical" parameters that may be provided in Freescale Semiconductor data sheets and/or specifications can and do vary in different applications and actual performance may vary over time. All operating parameters, including "Typicals", must be validated for each customer application by customer's technical experts. Freescale Semiconductor does not convey any license under its patent rights nor the rights of others. Freescale Semiconductor products are not designed, intended, or authorized for use as components in systems intended for surgical implant into the body, or other applications intended to support or sustain life, or for any other application in which the failure of the Freescale Semiconductor product could create a situation where personal injury or death may occur. Should Buyer purchase or use Freescale Semiconductor products for any such unintended or unauthorized application, Buyer shall indemnify and hold Freescale Semiconductor and its officers, employees, subsidiaries, affiliates, and distributors harmless against all claims, costs, damages, and expenses, and reasonable attorney fees arising out of, directly or indirectly, any claim of personal injury or death associated with such unintended or unauthorized use, even if such claim alleges that Freescale Semiconductor was negligent regarding the design or manufacture of the part.

Freescale™ and the Freescale logo are trademarks of Freescale Semiconductor, Inc. All other product or service names are the property of their respective owners.

© Freescale Semiconductor, Inc. 2005. All rights reserved.

Looking for pricing, stock, or lifecycle information?

Click below to explore more details on WIN SOURCE:

- ⊖ [View MC68HC908JB8ADW on WIN SOURCE](#)
- ⊖ [Freescale Semiconductor - NXP Information](#)

Optimize Your Supply Chain with WIN SOURCE Solutions

- ✓ Global Sourcing Solution
- ✓ Obsolete Management
- ✓ Cost Control Management
- ✓ Shortage Management
- ✓ Alternative Solution
- ✓ Excess Inventory Management