



**THE DATASHEET OF  
MC68HC711D3CFNE3**





**Freescale Semiconductor, Inc.**

# HC11

## MC68HC11D3 Technical Data

**Freescale Semiconductor, Inc.**

**For More Information On This Product,  
Go to: [www.freescale.com](http://www.freescale.com)**



**Freescale Semiconductor, Inc.**

**Freescale Semiconductor, Inc.**

**For More Information On This Product,  
Go to: [www.freescale.com](http://www.freescale.com)**



**Section 4**

**OPERATING MODES AND ON-CHIP MEMORY**

4.1	Operating Modes	4-1
4.1.1	Single-Chip Mode	4-1
4.1.2	Expanded Multiplexed Mode	4-1
4.1.3	Special Test Mode	4-2
4.1.4	Bootstrap Mode	4-2
4.2	Memory Map	4-3
4.2.1	Priority and Mode Select Register	4-6
4.2.2	System Initialization	4-8
4.2.2.1	CONFIG Register	4-8
4.2.2.2	INIT Register	4-9
4.2.2.3	OPTION Register	4-10

**Section 5**

**RESETS AND INTERRUPTS**

5.1	Resets	5-1
5.1.1	Power-On Reset	5-1
5.1.2	External Reset ( $\overline{\text{RESET}}$ )	5-1
5.1.3	COP Reset	5-1
5.1.4	Clock Monitor Reset	5-2
5.1.5	Option Register	5-3
5.1.6	CONFIG Register	5-4
5.2	Effects of Reset	5-4
5.2.1	CPU	5-4
5.2.2	Memory Map	5-4
5.2.3	Parallel I/O	5-5
5.2.4	Timer	5-5
5.2.5	Real-Time Interrupt	5-5
5.2.6	Pulse Accumulator	5-5
5.2.7	COP	5-6
5.2.8	SCI	5-6
5.2.9	SPI	5-6
5.2.10	System	5-6
5.3	Reset and Interrupt Priority	5-6
5.3.1	Highest Priority Interrupt and Miscellaneous Register	5-7
5.4	Interrupts	5-8
5.4.1	Interrupt Recognition and Register Stacking	5-9
5.4.2	Non-Maskable Interrupt Request $\overline{\text{XIRQ}}$	5-10
5.4.3	Illegal Opcode Trap	5-10
5.4.4	Software Interrupt	5-11
5.4.5	Maskable Interrupts	5-11
5.4.6	Reset and Interrupt Processing	5-11
5.5	Low-Power Operation	5-16
5.5.1	WAIT	5-16
5.5.2	STOP	5-17

**Section 6**

**PARALLEL I/O**

6.1	Port A	6-1
6.2	Port B	6-1
6.3	Port C	6-2

<b>Paragraph Number</b>	<b>Table of Contents (Cont.)</b>	<b>Page Number</b>
6.4	Port D . . . . .	6-2
6.5	Parallel I/O Control Register (PIOC) . . . . .	6-4

**Section 7**

**SERIAL COMMUNICATIONS INTERFACE**

7.1	Data Format . . . . .	7-1
7.2	Transmit Operation . . . . .	7-1
7.3	Receive Operation . . . . .	7-2
7.4	Wake-up Feature . . . . .	7-4
7.4.1	Idle-Line Wakeup . . . . .	7-4
7.4.2	Address-Mark Wakeup . . . . .	7-4
7.5	SCI Error Detection . . . . .	7-5
7.6	SCI Registers . . . . .	7-5
7.6.1	Serial Communications Data Register (SCDR) . . . . .	7-5
7.6.2	Serial Communications Control Register 1 (SCCR1) . . . . .	7-5
7.6.3	Serial Communications Control Register 2 (SCCR2) . . . . .	7-6
7.6.4	Serial Communication Status Register (SCSR) . . . . .	7-7
7.6.5	Baud Rate Register (BAUD) . . . . .	7-8
7.7	Status Flags and Interrupts . . . . .	7-10

**Section 8**

**SERIAL PERIPHERAL INTERFACE**

8.1	Functional Description . . . . .	8-1
8.2	SPI Transfer Formats . . . . .	8-2
8.2.1	Clock Phase and Polarity Controls . . . . .	8-3
8.3	SPI Signals . . . . .	8-3
8.3.1	Master In Slave Out . . . . .	8-4
8.3.2	Master Out Slave In . . . . .	8-4
8.3.3	Serial Clock . . . . .	8-4
8.3.4	Slave Select . . . . .	8-4
8.4	SPI System Errors . . . . .	8-4
8.5	SPI Registers . . . . .	8-5
8.5.1	Serial Peripheral Control . . . . .	8-6
8.5.2	Serial Peripheral Status . . . . .	8-7
8.5.3	Serial Peripheral Data I/O . . . . .	8-7

**Section 9**

**TIMING SYSTEM**

9.1	Timer Structure . . . . .	9-3
9.2	Input Capture . . . . .	9-4
9.2.1	Timer Control 2 Register . . . . .	9-5
9.2.2	Timer Input Capture Registers . . . . .	9-6
9.2.3	Timer Input Capture 4/Output Compare 5 Register . . . . .	9-6
9.3	Output Compare . . . . .	9-6
9.3.1	Timer Output Compare Registers . . . . .	9-7
9.3.2	Timer Compare Force Register . . . . .	9-8
9.3.3	Output Compare Mask Registers . . . . .	9-8
9.3.4	Output Compare 1 Data Register . . . . .	9-9
9.3.5	Timer Counter Register . . . . .	9-9
9.3.6	Timer Control 1 Register . . . . .	9-9
9.3.7	Timer Interrupt Mask 1 Register . . . . .	9-10
9.3.8	Timer Interrupt Flag 1 Register . . . . .	9-10

**Paragraph  
Number**

**Table of Contents (Cont.)**

**Page  
Number**

9.3.9	Timer Interrupt Mask 2 Register . . . . .	9-11
9.3.10	Timer Interrupt Flag 2 Register . . . . .	9-12
9.4	Real-Time Interrupt . . . . .	9-12
9.4.1	Timer Interrupt Flag 2 Register . . . . .	9-13
9.4.2	Pulse Accumulator Control Register . . . . .	9-14
9.5	Computer Operating Properly Watchdog Function . . . . .	9-15
9.6	Pulse Accumulator . . . . .	9-15
9.6.1	Pulse Accumulator Control Register . . . . .	9-17
9.6.2	Pulse Accumulator Count Register . . . . .	9-17
9.6.3	Pulse Accumulator Status and Interrupt Bits . . . . .	9-18

**Appendix A**

**ELECTRICAL CHARACTERISTICS**

**Appendix B**

**MECHANICAL DATA AND ORDERING INFORMATION**

B.1	Pin Assignments . . . . .	B-1
B.2	Package Dimensions . . . . .	B-3
B.3	Ordering Information . . . . .	B-3

**Appendix C**

**DEVELOPMENT SUPPORT**

C.1	Development System Tools . . . . .	C-1
C.2	MC68HC11D3 Development Tools . . . . .	C-1

**INDEX**



LIST OF ILLUSTRATIONS

Figure	Title	Page
1-1	MC68HC11D3 Block Diagram .....	1-2
2-1	Pin Assignments for 44-Pin PLCC .....	2-1
2-2	Pin Assignments for 40-Pin DIP .....	2-2
2-3	External Reset Circuit .....	2-3
2-4	Common Crystal Connections .....	2-3
2-5	External Oscillator Connections .....	2-4
2-6	One Crystal Driving Two MCUs .....	2-4
3-1	Programming Model .....	3-1
3-2	Stacking Operations .....	3-3
4-1	Address/Data Demultiplexing .....	4-2
4-2	MC68HC11D3 Memory Map .....	4-3
4-3	RAM Standby MODB/V <sub>STBY</sub> Connections .....	4-6
5-1	Processing Flow out of Reset (1 of 2) .....	5-12
5-2	Interrupt Priority Resolution (1 of 2) .....	5-14
5-3	Interrupt Source Resolution within SCI .....	5-16
7-1	SCI Transmitter Block Diagram .....	7-2
7-2	SCI Receiver Block Diagram .....	7-3
7-3	SCI Baud Rate Diagram .....	7-10
7-4	Interrupt Source Resolution within SCI .....	7-12
8-1	SPI Block Diagram .....	8-2
8-2	SPI Transfer Format .....	8-3
9-1	Timer Clock Divider Chains .....	9-2
9-2	Capture/Compare Block Diagram .....	9-4
9-3	Pulse Accumulator .....	9-16
A-1	Test Methods .....	A-3
A-2	Timer Inputs .....	A-4
A-3	POR and External Reset Timing Diagram .....	A-5
A-4	STOP Recovery Timing Diagram .....	A-6
A-5	WAIT Recovery Timing Diagram .....	A-7
A-6	Port Write Timing Diagram .....	A-8
A-7	Port Read Timing Diagram .....	A-8
A-8	Multiplexed Expansion Bus Timing Diagram .....	A-10
A-9	SPI Master Timing (CPHA = 0) .....	A-12

MC68HC11D3

TA



**LIST OF ILLUSTRATIONS**  
(Continued)

<b>Figure</b>	<b>Title</b>	<b>Page</b>
A-10	SPI Master Timing (CPHA = 1) .....	A-12
A-11	SPI Slave Timing (CPHA = 0) .....	A-13
A-12	SPI Slave Timing (CPHA = 1) .....	A-13
B-1	40-Pin DIP .....	B-1
B-2	44-Pin PLCC .....	B-2
B-3	44-Pin QFP .....	B-3

**Freescale Semiconductor, Inc.**



LIST OF TABLES

Table	Title	Page
2-1	Port Signal Functions.....	2-6
3-2	Instruction Set.....	3-8
4-1	Register and Control Bit Assignments .....	4-4
4-2	Hardware Mode Select Summary.....	4-6
4-3	RAM Mapping.....	4-9
4-4	Register Mapping.....	4-9
5-1	COP Time-out.....	5-2
5-2	Reset Cause, Reset Vector, and Operating Mode .....	5-4
5-3	Highest Priority Interrupt Selection .....	5-8
5-4	Interrupt and Reset Vector Assignments .....	5-9
5-5	Stacking Order on Entry to Interrupts .....	5-10
7-1	Baud Rate Prescale Selects .....	7-8
7-2	Baud Rate Selects .....	7-9
9-1	Timer Summary .....	9-3
9-2	Timer Control Configuration.....	9-5
9-3	Pulse Accumulator Timing.....	9-16
A-1	Maximum Ratings.....	A-1
A-2	Thermal Characteristics .....	A-1
A-3	DC Electrical Characteristics.....	A-2
A-4	Control Timing .....	A-4
A-5	Peripheral Port Timing.....	A-8
A-6	Expansion Bus Timing.....	A-9
A-7	Serial Peripheral Interface Timing.....	A-11
B-1	Ordering Information .....	B-3



**Freescale Semiconductor, Inc.**

**Freescale Semiconductor, Inc.**

**For More Information On This Product,  
Go to: [www.freescale.com](http://www.freescale.com)**

## SECTION 1 INTRODUCTION

The MC68HC11D3 and MC68HC11D0 are ROM-based high-performance microcontrollers (MCUs) based on the MC68HC11E9 design. Members of the Dx series are derived from the same mask and feature a high speed multiplexed bus capable of running at up to 3 MHz, and a fully static design that allows operations at frequencies to dc.

The only difference between the MCUs in the Dx series is whether or not the ROM has been tested and guaranteed.

### 1.1 Features

- MC68HC11 CPU
- Power Saving STOP and WAIT Modes
- 4 Kbytes of On-Chip ROM
- 192 Bytes of On-Chip RAM (All Saved During Standby)
- 16-Bit Timer System
  - 3 Input Capture (IC) Channels
  - 4 Output Compare (OC) Channels
  - One IC or OC Channel (Software Selectable)
- 8-Bit Pulse Accumulator
- Real-Time Interrupt Circuit
- Computer Operating Properly (COP) Watchdog System
- Synchronous Serial Peripheral Interface (SPI)
- Asynchronous Nonreturn to Zero (NRZ) Serial Communications Interface (SCI)
- 26 Input/Output (I/O) Pins
  - 16 Bidirectional I/O Pins
  - 3 Input Only Pins
  - 3 Output Only Pins (One Output Only Pin in the 40-Pin Package)
- Available in a 44-Pin Plastic Leaded Chip Carrier (PLCC) and 40-Pin Dual In-Line Package (DIP)

### 1.2 Structure

Refer to **Figure 1-1**, which shows the structure of the MC68HC11D3 MCU.

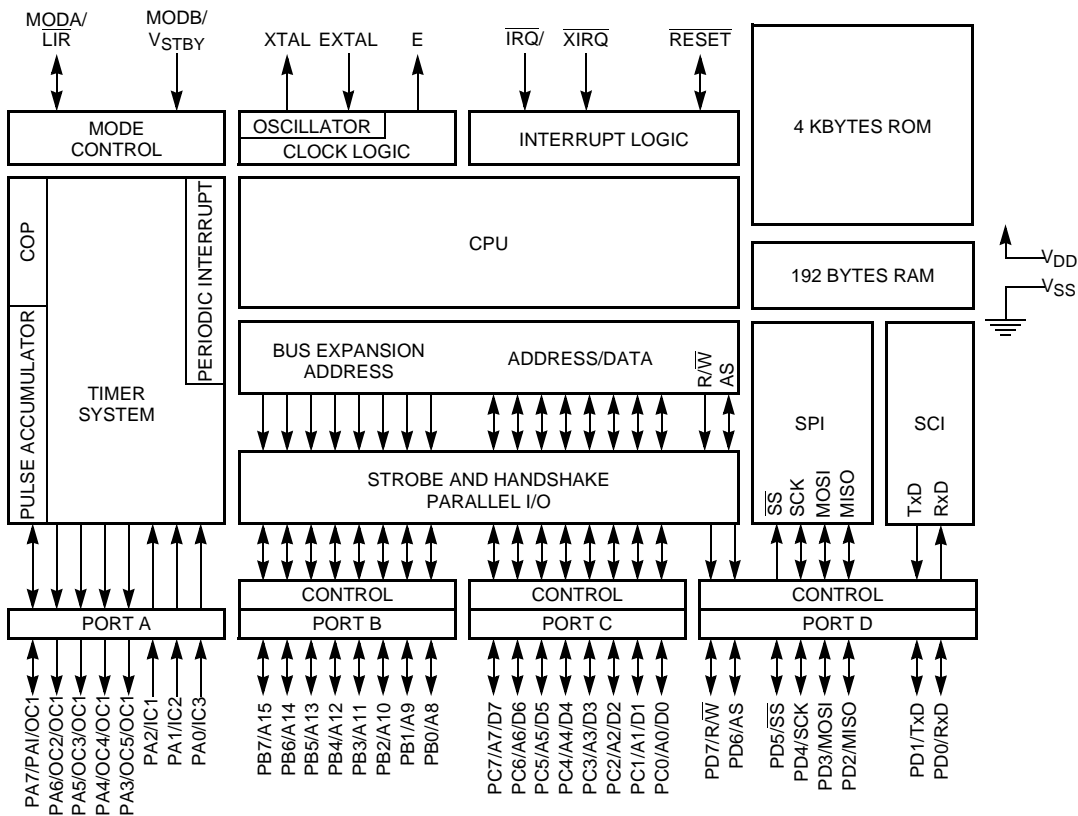

**Figure 1-1 MC68HC11D3 Block Diagram**

to Figure 2-1 and Figure 2-2, which shows the MC68HC11D3 pin assignments.

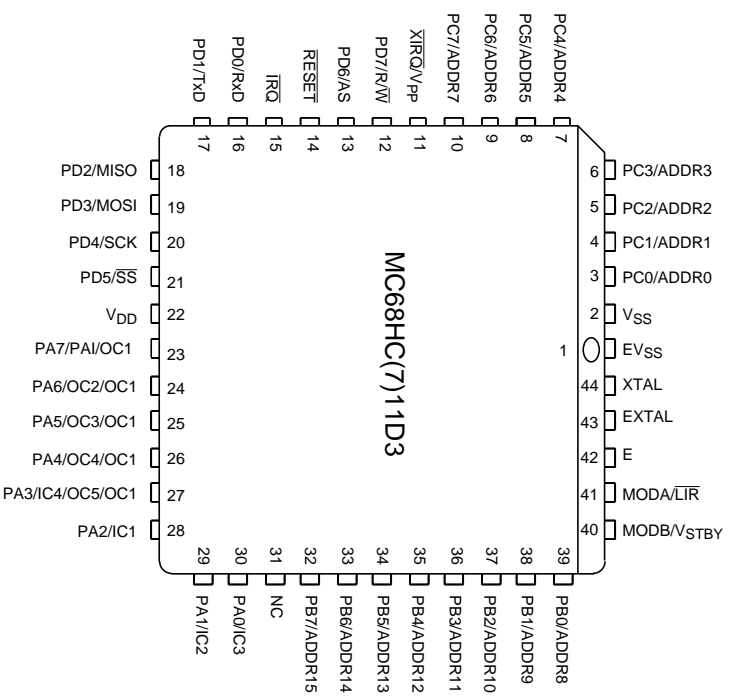
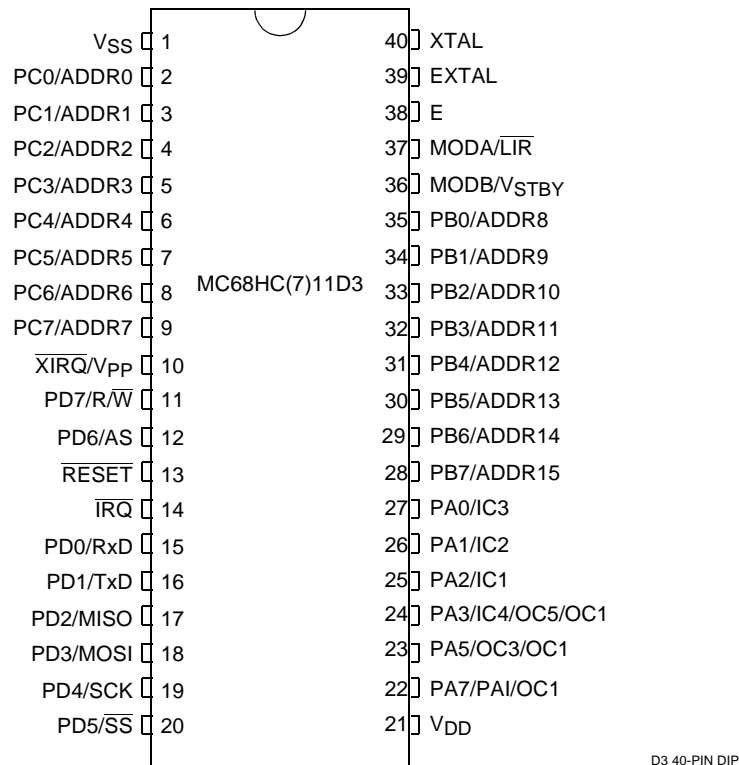

Figure 2-1 Pin Assignments for 44-Pin PLCC

# Freescale Semiconductor, Inc.





**Figure 2-2 Pin Assignments for 40-Pin DIP**

**2.1 V<sub>DD</sub>, V<sub>SS</sub>, and EV<sub>SS</sub>**

Power is supplied to the MCU through V<sub>DD</sub> and V<sub>SS</sub>. V<sub>SS</sub> is the power supply, and V<sub>SS</sub> is ground. EV<sub>SS</sub>, available on the 44-pin PLCC, is an additional ground pin that must be grounded with V<sub>SS</sub>. The MCU operates from a single 5-volt (nominal) power supply. Very fast signal transitions occur on the MCU pins. The short rise and fall times place high, short duration current demands on the power supply. To prevent noise problems, provide good power supply bypassing at the MCU. Also, use bypass capacitors that have good high-frequency characteristics and situate them as close to the MCU as possible. Bypass requirements vary, depending on how heavily the MCU pins are loaded.

**2.2 Reset ( $\overline{\text{RESET}}$ )**

An active low bidirectional control signal,  $\overline{\text{RESET}}$ , acts as an input to initialize the MCU to a known startup state. It also acts as an open-drain output to indicate that an internal failure has been detected in either the clock monitor or COP watchdog circuit. The CPU distinguishes between internal and external reset conditions by sensing whether the reset pin rises to a logic one in less than two E-clock cycles after a reset has occurred. It is not advisable to connect an external resistor-capacitor (RC) power-up delay circuit to the reset pin of M68HC11 devices because the circuit charge time

constant can cause the device to misinterpret the type of reset that occurred. Refer to **SECTION 5 RESETS AND INTERRUPTS** for further information.

**Figure 2-3** illustrates a reset circuit that uses an external switch. Use a low voltage interrupt circuit, however, to prevent corruption of RAM.

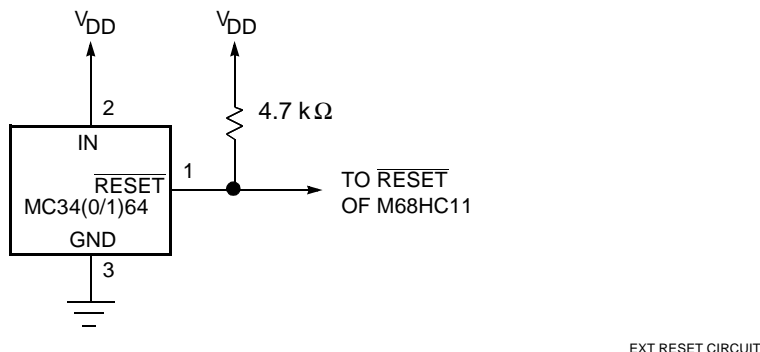

**Figure 2-3 External Reset Circuit**

### 2.3 Crystal Driver and External Clock Input (XTAL, EXTAL)

These two pins provide the interface for either a crystal or a CMOS compatible clock to control the internal clock generator circuitry. The frequency applied to these pins is four times higher than the desired E-clock rate.

The XTAL pin is normally left unterminated when an external CMOS compatible clock input is connected to the EXTAL pin. However, a 10 kΩ to 100 kΩ load resistor connected from XTAL to ground can be used to reduce RFI noise emission. The XTAL output is normally intended to drive only a crystal. The XTAL output can be buffered with a high impedance buffer, or it can be used to drive the EXTAL input of another M68HC11.

In all cases, use caution around the oscillator pins. Load capacitances shown in the oscillator circuits include all stray layout capacitances. Refer to **Figure 2-4**, **Figure 2-5**, and **Figure 2-6**.

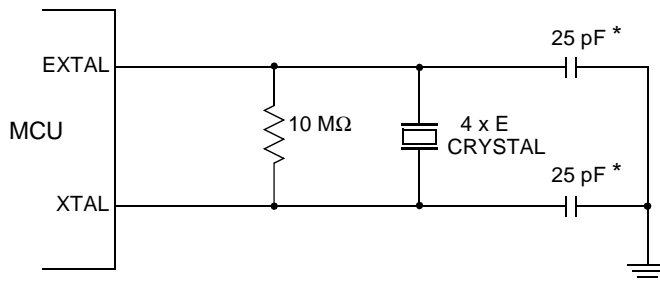

\* THIS VALUE INCLUDES ALL STRAY CAPACITANCES.

COMMON XTAL CONN

**Figure 2-4 Common Crystal Connections**

#### PIN DESCRIPTIONS

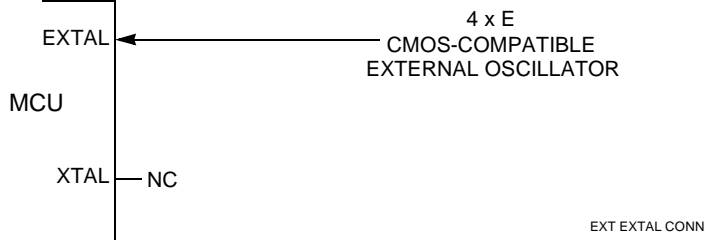

**Figure 2-5 External Oscillator Connections**

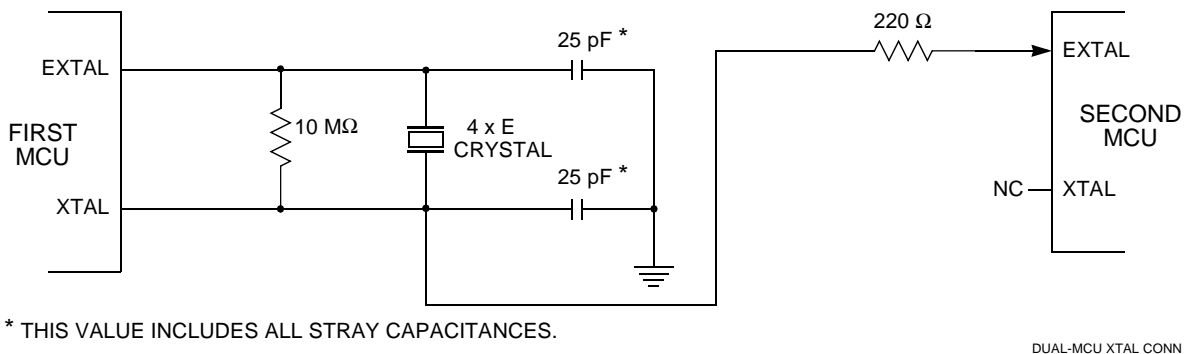

**Figure 2-6 One Crystal Driving Two MCUs**

**2.4 E-Clock Output (E)**

E is the output connection for the internally generated E clock. The signal from E is used as a timing reference. The frequency of the E-clock output is one fourth that of the input frequency at the XTAL and EXTAL pins. When E-clock output is low, an internal process is taking place. When it is high, data is being accessed. All clocks, including the E clock, are halted when the MCU is in STOP mode. The E clock can be turned off in single-chip modes to reduce the effects of radio frequency interference (RFI).

**2.5 Interrupt Request ( $\overline{\text{IRQ}}$ )**

The  $\overline{\text{IRQ}}$  input provides a means of applying asynchronous interrupt requests to the MCU. Either negative edge-sensitive triggering or level-sensitive triggering is program selectable (OPTION register).  $\overline{\text{IRQ}}$  is always configured to level-sensitive triggering at reset. Connect an external pullup resistor, typically 4.7 k $\Omega$ , to V<sub>DD</sub> when  $\overline{\text{IRQ}}$  is used in a level sensitive wired-OR configuration.

**2.6 Non-Maskable Interrupt ( $\overline{\text{XIRQ}}$ )**

The  $\overline{\text{XIRQ}}$  input provides a means of requesting a nonmaskable interrupt after reset initialization. During reset, the X bit in the condition code register (CCR) is set and any interrupt is masked until MCU software enables it. Because the  $\overline{\text{XIRQ}}$  input is level-

sensitive, it can be connected to a multiple-source wired-OR network with an external pullup resistor to  $V_{DD}$ .  $XIRQ$  is often used as a power loss detect interrupt.

Whenever  $\overline{XIRQ}$  or  $\overline{IRQ}$  are used with multiple interrupt sources ( $\overline{IRQ}$  must be configured for level-sensitive operation if there is more than one source of  $\overline{IRQ}$  interrupt), each source must drive the interrupt input with an open-drain type of driver to avoid contention between outputs. There should be a single pullup resistor near the MCU interrupt input pin (typically 4.7 k $\Omega$ ). There must also be an interlock mechanism at each interrupt source so that the source holds the interrupt line low until the MCU recognizes and acknowledges the interrupt request. If one or more interrupt sources are still pending after the MCU services a request, the interrupt line will still be held low and the MCU will be interrupted again as soon as the interrupt mask bit in the MCU is cleared (normally upon return from an interrupt). Refer to **SECTION 5 RESETS AND INTERRUPTS**.

## 2.7 MODA and MODB ( $\overline{MODA/LIR}$ , and $\overline{MODB/VSTBY}$ )

During reset, MODA and MODB select one of the four operating modes. Refer to **SECTION 4 OPERATING MODES AND ON-CHIP MEMORY**.

After the operating mode has been selected, the  $\overline{LIR}$  pin provides an open-drain output to indicate that execution of an instruction has begun. A series of E-clock cycles occurs during execution of each instruction. The  $\overline{LIR}$  signal goes low during the first E-clock cycle of each instruction (opcode fetch). This output is provided for assistance in program debugging.

The  $V_{STBY}$  pin is used to input RAM standby power. When the voltage on this pin is more than one MOS threshold (about 0.7 volts) above the  $V_{DD}$  voltage, the internal 192-byte RAM and part of the reset logic are powered from this signal rather than the  $V_{DD}$  input. This allows RAM contents to be retained without  $V_{DD}$  power applied to the MCU. Reset must be driven low before  $V_{DD}$  is removed and must remain low until  $V_{DD}$  has been restored to a valid level.

## 2.8 PD6/AS

This pin performs either of two separate functions, depending on the operating mode. In single-chip and bootstrap modes, the pin functions as input/output port D bit 6. In the expanded multiplexed and test modes, it provides an address strobe (AS) function. The AS can demultiplex the address and data signals at port C. Refer to **SECTION 4 OPERATING MODES AND ON-CHIP MEMORY** for further information.

## 2.9 PD7/R/ $\overline{W}$

This pin provides two separate functions, depending on the operating mode. In single-chip and bootstrap modes, PD7/R/ $\overline{W}$  acts as input/output port D bit 7. Refer to **SECTION 6 PARALLEL I/O** for further information.

In expanded multiplexed and test modes, PD7/R/ $\overline{W}$  performs a read/write function. PD7/R/ $\overline{W}$  controls the direction of transfers on the external data bus. A high on this pin indicates that a read cycle is in progress.

## 2.10 Port Signals

In the 44-pin PLCC package, 32 input/output lines are arranged into four 8-bit ports: A, B, C, and D. The lines of ports B, C, and D are fully bidirectional. Each of these four ports serves a purpose other than I/O, depending on the operating mode or peripheral functions selected. Note that ports B, C, and two bits of port D are available for I/O functions only in single-chip and bootstrap modes. Refer to **Table 2-1** for details about the 32 port signals' functions within different operating modes.

**Table 2-1 Port Signal Functions**

Port/Bit	Single-Chip and Bootstrap Mode	Expanded Multiplexed and Special Test Mode
PA0		PA0/IC3
PA1		PA1/IC2
PA2		PA2/IC1
PA3		PA3/OC5/IC4/OC1
PA4*		PA4/OC4/OC1
PA5		PA5/OC3/OC1
PA6*		PA6/OC2/OC1
PA7		PA7/PAI/OC1
PB0	PB0	ADDR8
PB1	PB1	ADDR9
PB2	PB2	ADDR10
PB3	PB3	ADDR11
PB4	PB4	ADDR12
PB5	PB5	ADDR13
PB6	PB6	ADDR14
PB7	PB7	ADDR15
PC0	PC0	ADDR0/DATA0
PC1	PC1	ADDR1/DATA1
PC2	PC2	ADDR2/DATA2
PC3	PC3	ADDR3/DATA3
PC4	PC4	ADDR4/DATA4
PC5	PC5	ADDR5/DATA5
PC6	PC6	ADDR6/DATA6
PC7	PC7	ADDR7/DATA7
PD0		PD0/RxD
PD1		PD1/TxD
PD2		PD2/MISO
PD3		PD3/MOSI
PD4		PD4/SCK
PD5		PD5/ $\overline{SS}$
PD6	PD6	AS
PD7	PD7	R/ $\overline{W}$

\*In the 40-pin package, pins PA4 and PA6 are not bonded. Their associated I/O and output compare functions are not available externally. They can still be used as internal software timers, however.

### 2.10.1 Port A

Port A can be read at any time. Inputs return the pin level; outputs return the pin driver input level. If written, port A stores the data in an internal latch. It drives the pins only if they are configured as outputs. Writes to port A do not change the pin state when the pins are configured for timer output compares.

Out of reset, port A bits 7 and [3:0] are general high impedance inputs, while bits [6:4] are outputs, driving low. Bidirectional lines PA7 and PA3 in PACTL are not changed and do not have any effect on those bits. When the output compare functions associated with these pins are disabled, the DDR bits in PACTL govern the I/O state.

Refer to **SECTION 6 PARALLEL I/O**.

### 2.10.2 Port B

Port B is an 8-bit general-purpose I/O port with a data register (PORTB) and a data direction register (DDRB). In single-chip mode, port B pins are general-purpose I/O pins (PB[7:0]). In the expanded multiplexed mode, all of the port B pins act as the high-order address bits (ADDR[15:8]) of the address bus.

Port B can be read at any time. Inputs return the sensed levels at the pin, while outputs return the input level of the port B pin drivers. If port B is written, the data is stored in an internal latch and can be driven only if port B is configured as general-purpose outputs in single-chip or bootstrap modes.

Port B pins are general-purpose inputs out of reset in single-chip and bootstrap modes. These pins are outputs (the high order address bits) out of reset in expanded multiplexed and test modes.

Refer to **SECTION 6 PARALLEL I/O**.

### 2.10.3 Port C

Port C is an 8-bit general-purpose I/O port with a data register (PORTC) and a data direction register (DDRC). In the single-chip mode, port C pins are general-purpose I/O pins (PC[7:0]). In the expanded multiplexed mode, port C pins are configured as multiplexed address/data pins. During the address cycle, bits [7:0] of the address are output on PC[7:0]. During the data cycle, bits [7:0] (PC[7:0]) are bidirectional data pins controlled by the  $R/\bar{W}$  signal.

Port C can be read at any time. Inputs return the sensed levels at the pin, while outputs return the input level of the port C pin drivers. If port C is written, the data is stored in an internal latch and can be driven only if port C is configured for general-purpose outputs in single-chip or bootstrap mode. Port C pins are general-purpose inputs out of reset in single-chip and bootstrap modes. These pins are multiplexed low-order address and data bus lines out of reset in expanded multiplexed and test modes.

The CWOM control bit in the PIOC register disables port C's P-channel output driver. CWOM simultaneously affects all eight bits of port C. Because the N-channel driver is not affected by CWOM, setting CWOM causes port C to become an open-drain-type

output port suitable for wired-OR operation. In wired-OR mode (a port C bit is at logic level zero), it is actively driven low by the N-channel driver. When a port C bit is at logic level one, the associated pin has high impedance, as neither the N- nor the P-channel devices are active. It is customary to have an external pullup resistor on lines that are driven by open-drain devices. Port C can only be configured for wired-OR operation when the MCU is in single-chip mode. Refer to **SECTION 6 PARALLEL I/O** for additional information about port C functions.

#### 2.10.4 Port D

Port D, an 8-bit, general-purpose I/O port has a data register (PORTD) and a data direction register (DDRD). The eight port D bits (D[7:0]) can be used for general-purpose I/O, for the serial communications interface (SCI) and serial peripheral interface (SPI) subsystems, or for bus data direction control.

Port D can be read at any time and inputs return the sensed levels at the pin; whereas, the outputs return the input level of the port D pin drivers. If PORTD is written, the data is stored in an internal latch, and can be driven only if port D is configured for general-purpose output. This port shares functions with the on-chip SCI and SPI subsystems, while bits 6 and 7 control the direction of data flow on the bus in expanded and special test modes.

Refer to **SECTION 6 PARALLEL I/O**.

## SECTION 3 CENTRAL PROCESSING UNIT

This section presents information on M68HC11 central processing unit (CPU) architecture, data types, addressing modes, the instruction set, and special operations, such as subroutine calls and interrupts.

The CPU is designed to treat all peripheral, I/O, and memory locations identically as addresses in the 64 Kbyte memory map. This is referred to as memory-mapped I/O. There are no special instructions for I/O that are separate from those used for memory. This architecture also allows accessing an operand from an external memory location with no execution-time penalty.

### 3.1 CPU Registers

M68HC11 CPU registers are an integral part of the CPU and are not addressed as if they were memory locations. The seven registers, discussed in the following paragraphs, are shown in **Figure 3-1**.

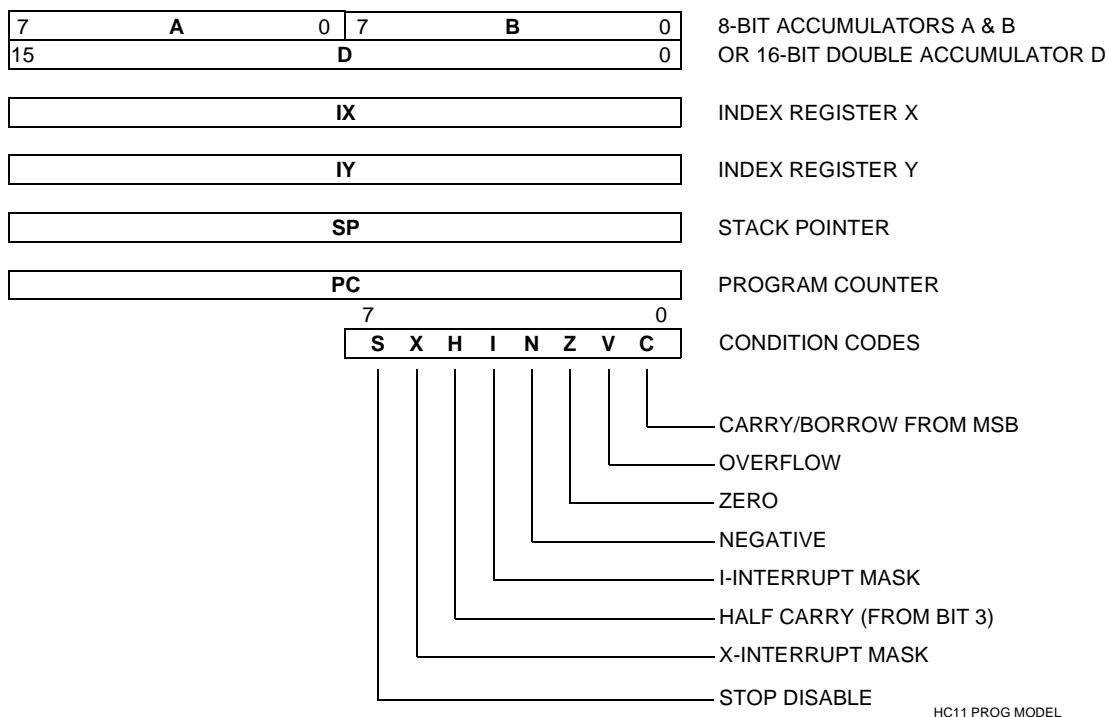

**Figure 3-1 Programming Model**

### 3.1.1 Accumulators A, B, and D

Accumulators A and B are general-purpose 8-bit registers that hold operands and results of arithmetic calculations or data manipulations. For some instructions, these two accumulators are treated as a single double-byte (16-bit) accumulator called accumulator D. Although most operations can use accumulators A or B interchangeably, the following exceptions apply:

The ABX and ABY instructions add the contents of 8-bit accumulator B to the contents of 16-bit register X or Y, but there are no equivalent instructions that use A instead of B.

The TAP and TPA instructions transfer data from accumulator A to the condition code register, or from the condition code register to accumulator A, however there are no equivalent instructions that use B rather than A.

The decimal adjust accumulator (DAA) instruction is used after binary-coded decimal (BCD) arithmetic operations, but there is no equivalent BCD instruction to adjust accumulator B.

The add, subtract, and compare instructions associated with both A and B (ABA, SBA, and CBA) only operate in one direction, making it important to plan ahead to ensure the correct operand is in the correct accumulator.

### 3.1.2 Index Register X (IX)

The IX register provides a 16-bit indexing value that can be added to the 8-bit offset provided in an instruction to create an effective address. The IX register can also be used as a counter or as a temporary storage register.

### 3.1.3 Index Register Y (IY)

The 16-bit IY register performs an indexed mode function similar to that of the IX register. However, most instructions using the IY register require an extra byte of machine code and an extra cycle of execution time because of the way the opcode map is implemented. Refer to **3.3 Opcodes and Operands** for further information.

### 3.1.4 Stack Pointer (SP)

The M68HC11 CPU has an automatic program stack. This stack can be located anywhere in the address space and can be any size up to the amount of memory available in the system. Normally the SP is initialized by one of the first instructions in an application program. The stack is configured as a data structure that grows downward from high memory to low memory. Each time a new byte is pushed onto the stack, the SP is decremented. Each time a byte is pulled from the stack, the SP is incremented. At any given time, the SP holds the 16-bit address of the next free location in the stack. **Figure 3-2** is a summary of SP operations.

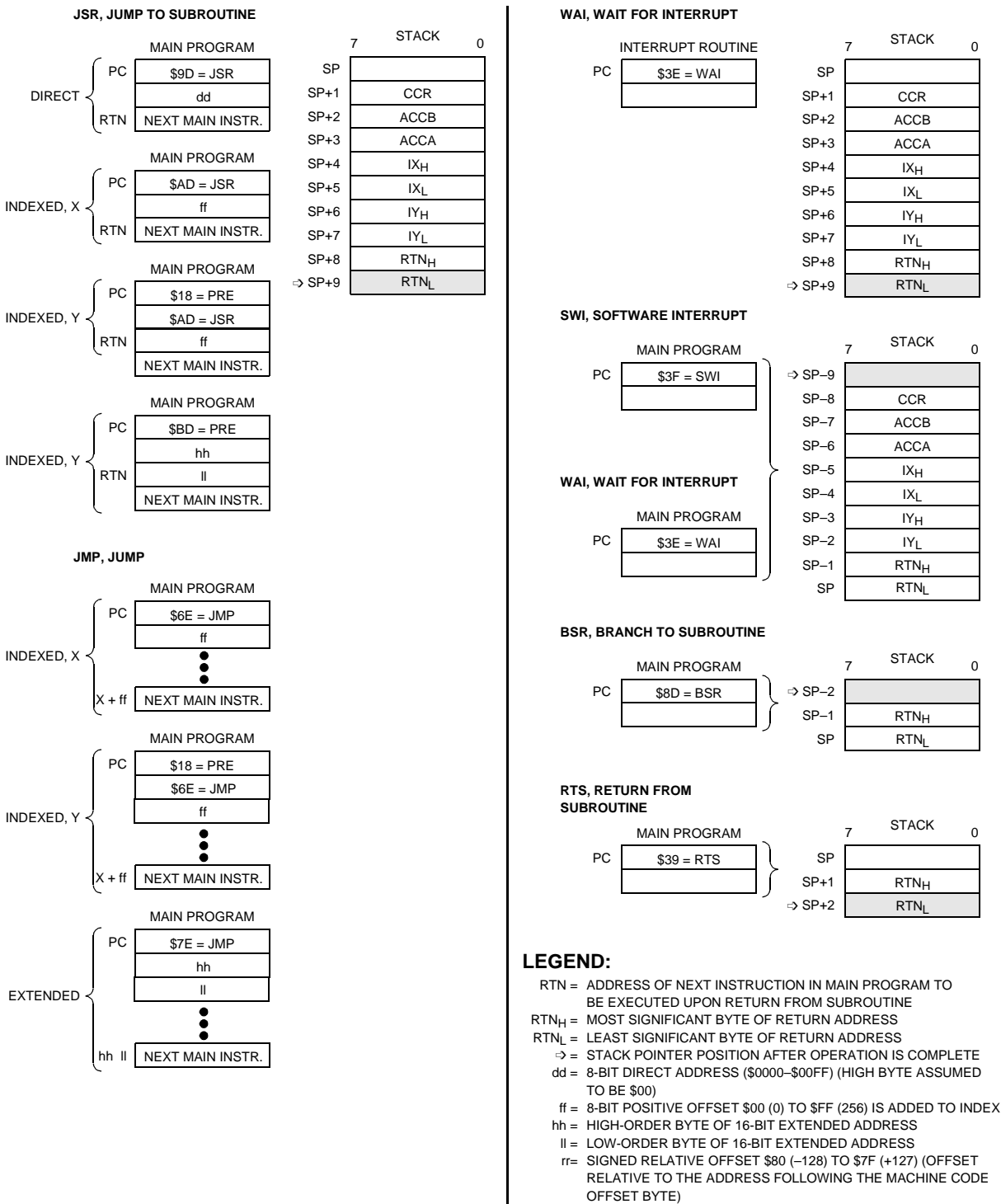

HC11 STACK OPERATIONS

Figure 3-2 Stacking Operations

When a subroutine is called by a jump to subroutine (JSR) or branch to subroutine (BSR) instruction, the address of the instruction after the JSR or BSR is automatically pushed onto the stack, least significant byte first. When the subroutine is finished, a return from subroutine (RTS) instruction is executed. The RTS pulls the previously stacked return address from the stack, and loads it into the program counter. Execution then continues at this recovered return address.

When an interrupt is recognized, the current instruction finishes normally, the return address (the current value in the program counter) is pushed onto the stack, all of the CPU registers are pushed onto the stack, and execution continues at the address specified by the vector for the interrupt. At the end of the interrupt service routine, an RTI instruction is executed. The RTI instruction causes the saved registers to be pulled off the stack in reverse order. Program execution resumes at the return address.

There are instructions that push and pull the A and B accumulators and the X and Y index registers. These instructions are often used to preserve program context. For example, pushing accumulator A onto the stack when entering a subroutine that uses accumulator A, and then pulling accumulator A off the stack just before leaving the subroutine, ensures that the contents of a register will be the same after returning from the subroutine as it was before starting the subroutine.

### 3.1.5 Program Counter (PC)

The program counter, a 16-bit register, contains the address of the next instruction to be executed. After reset, the program counter is initialized from one of six possible vectors, depending on operating mode and the cause of reset.

**Table 3-1 Reset Vector Comparison**

	POR or Pin	Clock Monitor	COP Watchdog
Normal	\$FFFE, F	\$FFFC, D	\$FFFA, B
Test or Boot	\$BFFE, F	\$BFFC, D	\$BFFA, B

### 3.1.6 Condition Code Register (CCR)

This 8-bit register contains five condition code indicators (C, V, Z, N, and H), two interrupt masking bits, (IRQ and XIRQ) and a stop disable bit (S). In the M68HC11 CPU, condition codes are automatically updated by most instructions. For example, load accumulator A (LDAA) and store accumulator A (STAA) instructions automatically set or clear the N, Z, and V condition code flags. Pushes, pulls, add B to X (ABX), add B to Y (ABY), and transfer/exchange instructions do not affect the condition codes. Refer to **Table 3-2**, which shows what condition codes are affected by a particular instruction.

#### 3.1.6.1 Carry/Borrow (C)

The C bit is set if the arithmetic logic unit (ALU) performs a carry or borrow during an arithmetic operation. The C bit also acts as an error flag for multiply and divide opera-

tions. Shift and rotate instructions operate with and through the carry bit to facilitate multiple-word shift operations.

### 3.1.6.2 Overflow (V)

The overflow bit is set if an operation causes an arithmetic overflow. Otherwise, the V bit is cleared.

### 3.1.6.3 Zero (Z)

The Z bit is set if the result of an arithmetic, logic, or data manipulation operation is zero. Otherwise, the Z bit is cleared. Compare instructions do an internal implied subtraction and the condition codes, including Z, reflect the results of that subtraction. A few operations (INX, DEX, INY, and DEY) affect the Z bit and no other condition flags. For these operations, only = and - conditions can be determined.

### 3.1.6.4 Negative (N)

The N bit is set if the result of an arithmetic, logic, or data manipulation operation is negative (MSB = 1). Otherwise, the N bit is cleared. A result is said to be negative if its most significant bit (MSB) is a one. A quick way to test whether the contents of a memory location has the MSB set is to load it into an accumulator and then check the status of the N bit.

### 3.1.6.5 Interrupt Mask (I)

The interrupt request ( $\overline{\text{IRQ}}$ ) mask (I bit) is a global mask that disables all maskable interrupt sources. While the I bit is set, interrupts can become pending, but the operation of the CPU continues uninterrupted until the I bit is cleared. After any reset, the I bit is set by default and can only be cleared by a software instruction. When an interrupt is recognized, the I bit is set after the registers are stacked, but before the interrupt vector is fetched. After the interrupt has been serviced, a return from interrupt instruction is normally executed, restoring the registers to the values that were present before the interrupt occurred. Normally, the I bit is zero after a return from interrupt is executed. Although the I bit can be cleared within an interrupt service routine, “nesting” interrupts in this way should only be done when there is a clear understanding of latency and of the arbitration mechanism. Refer to **SECTION 5 RESETS AND INTERRUPTS**.

### 3.1.6.6 Half Carry (H)

The H bit is set when a carry occurs between bits 3 and 4 of the arithmetic logic unit during an ADD, ABA, or ADC instruction. Otherwise, the H bit is cleared. Half carry is used during BCD operations.

### 3.1.6.7 X Interrupt Mask (X)

The  $\overline{\text{XIRQ}}$  mask (X) bit disables interrupts from the pin. After any reset, X is set by default and must be cleared by a software instruction. When an interrupt is recognized, the X and I bits are set after the registers are stacked, but before the interrupt vector is fetched. After the interrupt has been serviced, an RTI instruction is normally executed, causing the registers to be restored to the values that were present before the in-

errupt occurred. The X interrupt mask bit is set only by hardware (or acknowledge). X is cleared only by program instruction (TAP, where the associated bit of A is 0; or RTI, where bit 6 of the value loaded into the CCR from the stack has been cleared). There is no hardware action for clearing X.

### 3.1.6.8 Stop Disable (S)

Setting the STOP disable (S) bit prevents the STOP instruction from putting the M68HC11 into a low-power stop condition. If the STOP instruction is encountered by the CPU while the S bit is set, it is treated as a no-operation (NOP) instruction, and processing continues to the next instruction. S is set by reset —STOP disabled by default.

## 3.2 Data Types

The M68HC11 CPU supports the following data types:

- Bit data
- 8-bit and 16-bit signed and unsigned integers
- 16-bit unsigned fractions
- 16-bit addresses

A byte is eight bits wide and can be accessed at any byte location. A word is composed of two consecutive bytes with the most significant byte at the lower value address. Because the M68HC11 is an 8-bit CPU, there are no special requirements for alignment of instructions or operands.

## 3.3 Opcodes and Operands

The M68HC11 family of microcontrollers uses 8-bit opcodes. Each opcode identifies a particular instruction and associated addressing mode to the CPU. Several opcodes are required to provide each instruction with a range of addressing capabilities. Only 256 opcodes would be available if the range of values were restricted to the number able to be expressed in 8-bit binary numbers.

A four-page opcode map has been implemented to expand the number of instructions. An additional byte, called a prebyte, directs the processor from page 0 of the opcode map to one of the other three pages. As its name implies, the additional byte precedes the opcode.

A complete instruction consists of a prebyte, if any, an opcode, and zero, one, two, or three operands. The operands contain information the CPU needs for executing the instruction. Complete instructions can be from one to five bytes long.

## 3.4 Addressing Modes

Six addressing modes; immediate, direct, extended, indexed, inherent, and relative, detailed in the following paragraphs, can be used to access memory. All modes except inherent mode use an effective address. The effective address is the memory address from which the argument is fetched or stored, or the address from which execution is

to proceed. The effective address can be specified within an instruction, or it can be calculated.

### 3.4.1 Immediate

In the immediate addressing mode an argument is contained in the byte(s) immediately following the opcode. The number of bytes following the opcode matches the size of the register or memory location being operated on. There are two-, three-, and four- (if prebyte is required) byte immediate instructions. The effective address is the address of the byte following the instruction.

### 3.4.2 Direct

In the direct addressing mode, the low-order byte of the operand address is contained in a single byte following the opcode, and the high-order byte of the address is assumed to be \$00. Addresses \$00–\$FF are thus accessed directly, using two-byte instructions. Execution time is reduced by eliminating the additional memory access required for the high-order address byte. In most applications, this 256-byte area is reserved for frequently referenced data. In M68HC11 MCUs, the memory map can be configured for combinations of internal registers, RAM or external memory to occupy these addresses.

#### 3.4.2.1 Extended

In the extended addressing mode, the effective address of the argument is contained in two bytes following the opcode byte. These are three-byte instructions (or four-byte instructions if a prebyte is required). One or two bytes are needed for the opcode and two for the effective address.

#### 3.4.2.2 Indexed

In the indexed addressing mode, an 8-bit unsigned offset contained in the instruction is added to the value contained in an index register (IX or IY) — the sum is the effective address. This addressing mode allows referencing any memory location in the 64 Kbyte address space. These are from two- to five-byte instructions, depending on whether or not a prebyte is required.

#### 3.4.2.3 Inherent

In the inherent addressing mode, all the information necessary to execute the instruction is contained in the opcode. Operations that use only the index registers or accumulators, as well as control instructions with no arguments, are included in this addressing mode. These are one- or two-byte instructions.

#### 3.4.2.4 Relative

The relative addressing mode is used only for branch instructions. If the branch condition is true, an 8-bit signed offset included in the instruction is added to the contents of the program counter to form the effective branch address. Otherwise, control proceeds to the next instruction. These are usually two-byte instructions.

### 3.5 Instruction Set

Refer to **Table 3-2**, which shows all the M68HC11 instructions in all possible addressing modes. For each instruction, the table shows the operand construction, the number of machine code bytes, and execution time in CPU E-clock cycles.

**Table 3-2 Instruction Set (Sheet 1 of 7)**

Mnemonic	Operation	Description	Addressing Mode	Instruction			Condition Codes								
				Opcode	Operand	Cycles	S	X	H	I	N	Z	V	C	
ABA	Add Accumulators	$A + B \Rightarrow A$	INH	1B	—	2	—	—	Δ	—	Δ	Δ	Δ	Δ	
ABX	Add B to X	$IX + (00 : B) \Rightarrow IX$	INH	3A	—	3	—	—	—	—	—	—	—	—	
ABY	Add B to Y	$IY + (00 : B) \Rightarrow IY$	INH	18 3A	—	4	—	—	—	—	—	—	—	—	
ADCA (opr)	Add with Carry to A	$A + M + C \Rightarrow A$	A	IMM	89	ii	2	—	—	Δ	—	Δ	Δ	Δ	
			A	DIR	99	dd	3								
			A	EXT	B9	hh ll	4								
			A	IND,X	A9	ff	4								
			A	IND,Y	A9	ff	5								
ADCB (opr)	Add with Carry to B	$B + M + C \Rightarrow B$	B	IMM	C9	ii	2	—	—	Δ	—	Δ	Δ	Δ	
			B	DIR	D9	dd	3								
			B	EXT	F9	hh ll	4								
			B	IND,X	E9	ff	4								
			B	IND,Y	E9	ff	5								
ADDA (opr)	Add Memory to A	$A + M \Rightarrow A$	A	IMM	8B	ii	2	—	—	Δ	—	Δ	Δ	Δ	
			A	DIR	9B	dd	3								
			A	EXT	BB	hh ll	4								
			A	IND,X	AB	ff	4								
			A	IND,Y	AB	ff	5								
ADDB (opr)	Add Memory to B	$B + M \Rightarrow B$	B	IMM	CB	ii	2	—	—	Δ	—	Δ	Δ	Δ	
			B	DIR	DB	dd	3								
			B	EXT	FB	hh ll	4								
			B	IND,X	EB	ff	4								
			B	IND,Y	EB	ff	5								
ADDD (opr)	Add 16-Bit to D	$D + (M : M + 1) \Rightarrow D$		IMM	C3	jj kk	4	—	—	—	—	Δ	Δ	Δ	Δ
				DIR	D3	dd	5								
				EXT	F3	hh ll	6								
				IND,X	E3	ff	6								
				IND,Y	E3	ff	7								
ANDA (opr)	AND A with Memory	$A \cdot M \Rightarrow A$	A	IMM	84	ii	2	—	—	—	—	Δ	Δ	0	—
			A	DIR	94	dd	3								
			A	EXT	B4	hh ll	4								
			A	IND,X	A4	ff	4								
			A	IND,Y	A4	ff	5								
ANDB (opr)	AND B with Memory	$B \cdot M \Rightarrow B$	B	IMM	C4	ii	2	—	—	—	—	Δ	Δ	0	—
			B	DIR	D4	dd	3								
			B	EXT	F4	hh ll	4								
			B	IND,X	E4	ff	4								
			B	IND,Y	E4	ff	5								
ASL (opr)	Arithmetic Shift Left			EXT	78	hh ll	6	—	—	—	—	Δ	Δ	Δ	Δ
				IND,X	68	ff	6								
				IND,Y	68	ff	7								
					68	ff	7								
ASLA	Arithmetic Shift Left A		A	INH	48	—	2	—	—	—	—	Δ	Δ	Δ	Δ
ASLB	Arithmetic Shift Left B		B	INH	58	—	2	—	—	—	—	Δ	Δ	Δ	Δ
ASLD	Arithmetic Shift Left D			INH	05	—	3	—	—	—	—	Δ	Δ	Δ	Δ
ASR	Arithmetic Shift Right			EXT	77	hh ll	6	—	—	—	—	Δ	Δ	Δ	Δ
				IND,X	67	ff	6								
				IND,Y	67	ff	7								
ASRA	Arithmetic Shift Right A		A	INH	47	—	2	—	—	—	—	Δ	Δ	Δ	Δ
ASRB	Arithmetic Shift Right B		B	INH	57	—	2	—	—	—	—	Δ	Δ	Δ	Δ
BCC (rel)	Branch if Carry Clear	? C = 0	REL	24	rr	3	—	—	—	—	—	—	—	—	—

Freescale Semiconductor, Inc.

Table 3-2 Instruction Set (Sheet 2 of 7)

Mnemonic	Operation	Description	Addressing Mode	Instruction			Condition Codes								
				Opcode	Operand	Cycles	S	X	H	I	N	Z	V	C	
BCLR (opr) (msk)	Clear Bit(s)	$M \cdot (mm) \Rightarrow M$	DIR IND,X IND,Y	15	dd mm	6	—	—	—	—	$\Delta$	$\Delta$	0	—	
				1D	ff mm	7	—	—	—	—	—	—	—	—	
				18	1D ff mm	8	—	—	—	—	—	—	—	—	—
BCS (rel)	Branch if Carry Set	? C = 1	REL	25	rr	3	—	—	—	—	—	—	—	—	
BEQ (rel)	Branch if = Zero	? Z = 1	REL	27	rr	3	—	—	—	—	—	—	—	—	
BGE (rel)	Branch if $\Delta$ Zero	? N $\oplus$ V = 0	REL	2C	rr	3	—	—	—	—	—	—	—	—	
BGT (rel)	Branch if > Zero	? Z + (N $\oplus$ V) = 0	REL	2E	rr	3	—	—	—	—	—	—	—	—	
BHI (rel)	Branch if Higher	? C + Z = 0	REL	22	rr	3	—	—	—	—	—	—	—	—	
BHS (rel)	Branch if Higher or Same	? C = 0	REL	24	rr	3	—	—	—	—	—	—	—	—	
BITA (opr)	Bit(s) Test A with Memory	A • M	A A A A A	IMM	85	ii	2	—	—	—	—	$\Delta$	$\Delta$	0	—
				DIR	95	dd	3	—	—	—	—	—	—	—	
				EXT	B5	hh ll	4	—	—	—	—	—	—	—	
				IND,X	A5	ff	4	—	—	—	—	—	—	—	
				IND,Y	18	A5 ff	4 5	—	—	—	—	—	—	—	—
BITB (opr)	Bit(s) Test B with Memory	B • M	B B B B B	IMM	C5	ii	2	—	—	—	—	$\Delta$	$\Delta$	0	—
				DIR	D5	dd	3	—	—	—	—	—	—	—	
				EXT	F5	hh ll	4	—	—	—	—	—	—	—	
				IND,X	E5	ff	4	—	—	—	—	—	—	—	
				IND,Y	18	E5 ff	4 5	—	—	—	—	—	—	—	—
BLE (rel)	Branch if $\Delta$ Zero	? Z + (N $\oplus$ V) = 1	REL	2F	rr	3	—	—	—	—	—	—	—	—	
BLO (rel)	Branch if Lower	? C = 1	REL	25	rr	3	—	—	—	—	—	—	—	—	
BLS (rel)	Branch if Lower or Same	? C + Z = 1	REL	23	rr	3	—	—	—	—	—	—	—	—	
BLT (rel)	Branch if < Zero	? N $\oplus$ V = 1	REL	2D	rr	3	—	—	—	—	—	—	—	—	
BMI (rel)	Branch if Minus	? N = 1	REL	2B	rr	3	—	—	—	—	—	—	—	—	
BNE (rel)	Branch if not = Zero	? Z = 0	REL	26	rr	3	—	—	—	—	—	—	—	—	
BPL (rel)	Branch if Plus	? N = 0	REL	2A	rr	3	—	—	—	—	—	—	—	—	
BRA (rel)	Branch Always	? 1 = 1	REL	20	rr	3	—	—	—	—	—	—	—	—	
BRCLR(opr) (msk) (rel)	Branch if Bit(s) Clear	$? M \cdot mm = 0$	DIR IND,X IND,Y	13	dd mm rr	6	—	—	—	—	—	—	—	—	
				1F	ff mm rr	7	—	—	—	—	—	—	—		
				18	1F ff mm rr	8	—	—	—	—	—	—	—	—	
BRN (rel)	Branch Never	? 1 = 0	REL	21	rr	3	—	—	—	—	—	—	—	—	
BRSET(opr) (msk) (rel)	Branch if Bit(s) Set	$? (M) \cdot mm = 0$	DIR IND,X IND,Y	12	dd mm rr	6	—	—	—	—	—	—	—		
				1E	ff mm rr	7	—	—	—	—	—	—	—		
				18	1E ff mm rr	8	—	—	—	—	—	—	—	—	
BSET (opr) (msk)	Set Bit(s)	$M + mm \Rightarrow M$	DIR IND,X IND,Y	14	dd mm	6	—	—	—	—	$\Delta$	$\Delta$	0	—	
				1C	ff mm	7	—	—	—	—	—	—	—		
				18	1C ff mm	8	—	—	—	—	—	—	—	—	
BSR (rel)	Branch to Subroutine	See Figure 3–2	REL	8D	rr	6	—	—	—	—	—	—	—	—	
BVC (rel)	Branch if Overflow Clear	? V = 0	REL	28	rr	3	—	—	—	—	—	—	—	—	
BVS (rel)	Branch if Overflow Set	? V = 1	REL	29	rr	3	—	—	—	—	—	—	—	—	
CBA	Compare A to B	A – B	INH	11	—	2	—	—	—	—	$\Delta$	$\Delta$	$\Delta$	$\Delta$	
CLC	Clear Carry Bit	0 $\Rightarrow$ C	INH	0C	—	2	—	—	—	—	—	—	—	0	
CLI	Clear Interrupt Mask	0 $\Rightarrow$ I	INH	0E	—	2	—	—	—	0	—	—	—	—	
CLR (opr)	Clear Memory Byte	0 $\Rightarrow$ M	EXT IND,X IND,Y	7F	hh ll	6	—	—	—	—	0	1	0	0	
				6F	ff	6	—	—	—	—	—	—	—	—	
				18	6F ff	7	—	—	—	—	—	—	—	—	—

Freescale Semiconductor, Inc.

## Table 3-2 Instruction Set (Sheet 3 of 7)

Mnemonic	Operation	Description	Addressing Mode		Instruction			Condition Codes								
					Opcode	Operand	Cycles	S	X	H	I	N	Z	V	C	
CLRA	Clear Accumulator A	$0 \Rightarrow A$	A	INH	4F	—	2	—	—	—	—	0	1	0	0	
CLRB	Clear Accumulator B	$0 \Rightarrow B$	B	INH	5F	—	2	—	—	—	—	0	1	0	0	
CLV	Clear Overflow Flag	$0 \Rightarrow V$		INH	0A	—	2	—	—	—	—	—	—	0	—	
CMPA (opr)	Compare A to Memory	A – M	A	IMM	81	ii	2	—	—	—	—	$\Delta$	$\Delta$	$\Delta$	$\Delta$	
				DIR	91	dd	3									
				EXT	B1	hh ll	4									
				IND,X	A1	ff	4									
				IND,Y	A1	ff	5									
CMPB (opr)	Compare B to Memory	B – M	B	IMM	C1	ii	2	—	—	—	—	$\Delta$	$\Delta$	$\Delta$	$\Delta$	
				DIR	D1	dd	3									
				EXT	F1	hh ll	4									
				IND,X	E1	ff	4									
				IND,Y	E1	ff	5									
COM (opr)	Ones Complement Memory Byte	$\$FF - M \Rightarrow M$		EXT	73	hh ll	6	—	—	—	—	$\Delta$	$\Delta$	0	1	
				IND,X	63	ff	6									
				IND,Y	63	ff	7									
COMA	Ones Complement A	$\$FF - A \Rightarrow A$	A	INH	43	—	2	—	—	—	—	$\Delta$	$\Delta$	0	1	
COMB	Ones Complement B	$\$FF - B \Rightarrow B$	B	INH	53	—	2	—	—	—	—	$\Delta$	$\Delta$	0	1	
CPD (opr)	Compare D to Memory 16-Bit	D – M : M + 1		IMM	1A	83	jj kk	5	—	—	—	—	$\Delta$	$\Delta$	$\Delta$	$\Delta$
				DIR	1A	93	dd	6								
				EXT	1A	B3	hh ll	7								
				IND,X	1A	A3	ff	7								
				IND,Y	CD	A3	ff	7								
CPX (opr)	Compare X to Memory 16-Bit	IX – M : M + 1		IMM	8C	jj kk	4	—	—	—	—	$\Delta$	$\Delta$	$\Delta$	$\Delta$	
				DIR	9C	dd	5									
				EXT	BC	hh ll	6									
				IND,X	AC	ff	6									
				IND,Y	CD	AC	ff									7
CPY (opr)	Compare Y to Memory 16-Bit	IY – M : M + 1		IMM	18	8C	jj kk	5	—	—	—	—	$\Delta$	$\Delta$	$\Delta$	$\Delta$
				DIR	18	9C	dd	6								
				EXT	18	BC	hh ll	7								
				IND,X	1A	AC	ff	7								
				IND,Y	18	AC	ff	7								
DAA	Decimal Adjust A	Adjust Sum to BCD		INH	19	—	2	—	—	—	—	$\Delta$	$\Delta$	$\Delta$	$\Delta$	
DEC (opr)	Decrement Memory Byte	M – 1 $\Rightarrow$ M		EXT	7A	hh ll	6	—	—	—	—	$\Delta$	$\Delta$	$\Delta$	—	
				IND,X	6A	ff	6									
				IND,Y	6A	ff	7									
DECA	Decrement Accumulator A	A – 1 $\Rightarrow$ A	A	INH	4A	—	2	—	—	—	—	$\Delta$	$\Delta$	$\Delta$	—	
DECB	Decrement Accumulator B	B – 1 $\Rightarrow$ B	B	INH	5A	—	2	—	—	—	—	$\Delta$	$\Delta$	$\Delta$	—	
DES	Decrement Stack Pointer	SP – 1 $\Rightarrow$ SP		INH	34	—	3	—	—	—	—	—	—	—	—	
DEX	Decrement Index Register X	IX – 1 $\Rightarrow$ IX		INH	09	—	3	—	—	—	—	—	$\Delta$	—	—	
DEY	Decrement Index Register Y	IY – 1 $\Rightarrow$ IY		INH	18	09	—	4	—	—	—	—	$\Delta$	—	—	
EORA (opr)	Exclusive OR A with Memory	A $\oplus$ M $\Rightarrow$ A	A	IMM	88	ii	2	—	—	—	—	$\Delta$	$\Delta$	0	—	
				DIR	98	dd	3									
				EXT	B8	hh ll	4									
				IND,X	A8	ff	4									
				IND,Y	A8	ff	5									
EORB (opr)	Exclusive OR B with Memory	B $\oplus$ M $\Rightarrow$ B	B	IMM	C8	ii	2	—	—	—	—	$\Delta$	$\Delta$	0	—	
				DIR	D8	dd	3									
				EXT	F8	hh ll	4									
				IND,X	E8	ff	4									
				IND,Y	18	E8	ff									5
FDIV	Fractional Divide 16 by 16	D / IX $\Rightarrow$ IX; r $\Rightarrow$ D		INH	03	—	41	—	—	—	—	—	$\Delta$	$\Delta$	$\Delta$	
IDIV	Integer Divide 16 by 16	D / IX $\Rightarrow$ IX; r $\Rightarrow$ D		INH	02	—	41	—	—	—	—	—	$\Delta$	0	$\Delta$	

Freescale Semiconductor, Inc.

**Table 3-2 Instruction Set (Sheet 4 of 7)**

Mnemonic	Operation	Description	Addressing Mode	Instruction			Condition Codes							
				Opcode	Operand	Cycles	S	X	H	I	N	Z	V	C
INC (opr)	Increment Memory Byte	$M + 1 \Rightarrow M$	EXT IND,X IND,Y	7C	hh ll	6	—	—	—	—	$\Delta$	$\Delta$	$\Delta$	—
				6C	ff	6								
				18 6C	ff	7								
INCA	Increment Accumulator A	$A + 1 \Rightarrow A$	A INH	4C	—	2	—	—	—	—	$\Delta$	$\Delta$	$\Delta$	—
INCB	Increment Accumulator B	$B + 1 \Rightarrow B$	B INH	5C	—	2	—	—	—	—	$\Delta$	$\Delta$	$\Delta$	—
INS	Increment Stack Pointer	$SP + 1 \Rightarrow SP$	INH	31	—	3	—	—	—	—	—	—	—	—
INX	Increment Index Register X	$IX + 1 \Rightarrow IX$	INH	08	—	3	—	—	—	—	—	$\Delta$	—	—
INY	Increment Index Register Y	$IY + 1 \Rightarrow IY$	INH	18 08	—	4	—	—	—	—	—	$\Delta$	—	—
JMP (opr)	Jump	See Figure 3-2	EXT IND,X IND,Y	7E	hh ll	3	—	—	—	—	—	—	—	—
				6E	ff	3								
				18 6E	ff	4								
JSR (opr)	Jump to Subroutine	See Figure 3-2	DIR EXT IND,X IND,Y	9D	dd	5	—	—	—	—	—	—	—	—
				BD	hh ll	6								
				AD	ff	6								
				18 AD	ff	7								
LDAA (opr)	Load Accumulator A	$M \Rightarrow A$	A IMM A DIR A EXT A IND,X A IND,Y	86	ii	2	—	—	—	—	$\Delta$	$\Delta$	0	—
				96	dd	3								
				B6	hh ll	4								
				A6	ff	4								
				18 A6	ff	5								
LDAB (opr)	Load Accumulator B	$M \Rightarrow B$	B IMM B DIR B EXT B IND,X B IND,Y	C6	ii	2	—	—	—	—	$\Delta$	$\Delta$	0	—
				D6	dd	3								
				F6	hh ll	4								
				E6	ff	4								
				18 E6	ff	5								
LDD (opr)	Load Double Accumulator D	$M \Rightarrow A, M + 1 \Rightarrow B$	IMM DIR EXT IND,X IND,Y	CC	jj kk	3	—	—	—	—	$\Delta$	$\Delta$	0	—
				DC	dd	4								
				FC	hh ll	5								
				EC	ff	5								
				18 EC	ff	6								
LDS (opr)	Load Stack Pointer	$M : M + 1 \Rightarrow SP$	IMM DIR EXT IND,X IND,Y	8E	jj kk	3	—	—	—	—	$\Delta$	$\Delta$	0	—
				9E	dd	4								
				BE	hh ll	5								
				AE	ff	5								
				18 AE	ff	6								
LDX (opr)	Load Index Register X	$M : M + 1 \Rightarrow IX$	IMM DIR EXT IND,X IND,Y	CE	jj kk	3	—	—	—	—	$\Delta$	$\Delta$	0	—
				DE	dd	4								
				FE	hh ll	5								
				EE	ff	5								
				CD EE	ff	6								
LDY (opr)	Load Index Register Y	$M : M + 1 \Rightarrow IY$	IMM DIR EXT IND,X IND,Y	18 CE	jj kk	4	—	—	—	—	$\Delta$	$\Delta$	0	—
				18 DE	dd	5								
				18 FE	hh ll	6								
				1A EE	ff	6								
				18 EE	ff	6								
LSL (opr)	Logical Shift Left		EXT IND,X IND,Y	78	hh ll	6	—	—	—	—	$\Delta$	$\Delta$	$\Delta$	$\Delta$
				68	ff	6								
				18 68	ff	7								
LSLA	Logical Shift Left A		A INH	48	—	2	—	—	—	—	$\Delta$	$\Delta$	$\Delta$	$\Delta$
LSLB	Logical Shift Left B		B INH	58	—	2	—	—	—	—	$\Delta$	$\Delta$	$\Delta$	$\Delta$
LSLD	Logical Shift Left Double		INH	05	—	3	—	—	—	—	$\Delta$	$\Delta$	$\Delta$	$\Delta$
LSR (opr)	Logical Shift Right		EXT IND,X IND,Y	74	hh ll	6	—	—	—	—	0	$\Delta$	$\Delta$	$\Delta$
				64	ff	6								
				18 64	ff	7								
LSRA	Logical Shift Right A		A INH	44	—	2	—	—	—	—	0	$\Delta$	$\Delta$	$\Delta$

Freescale Semiconductor, Inc.

Table 3-2 Instruction Set (Sheet 5 of 7)

Mnemonic	Operation	Description	Addressing Mode	Instruction			Condition Codes								
				Opcode	Operand	Cycles	S	X	H	I	N	Z	V	C	
LSRB	Logical Shift Right B		B	INH	54	—	2	—	—	—	—	0	Δ	Δ	Δ
LSRD	Logical Shift Right Double			INH	04	—	3	—	—	—	—	0	Δ	Δ	Δ
MUL	Multiply 8 by 8	$A * B \Rightarrow D$		INH	3D	—	10	—	—	—	—	—	—	—	Δ
NEG (opr)	Two's Complement Memory Byte	$0 - M \Rightarrow M$		EXT IND,X IND,Y	70 60 60	hh ll ff ff	6 6 7	—	—	—	—	Δ	Δ	Δ	Δ
NEGA	Two's Complement A	$0 - A \Rightarrow A$	A	INH	40	—	2	—	—	—	—	Δ	Δ	Δ	Δ
NEGB	Two's Complement B	$0 - B \Rightarrow B$	B	INH	50	—	2	—	—	—	—	Δ	Δ	Δ	Δ
NOP	No operation	No Operation		INH	01	—	2	—	—	—	—	—	—	—	—
ORAA (opr)	OR Accumulator A (Inclusive)	$A + M \Rightarrow A$	A	IMM DIR EXT IND,X IND,Y	8A 9A BA AA AA	ii dd hh ll ff ff	2 3 4 4 5	—	—	—	—	Δ	Δ	0	—
ORAB (opr)	OR Accumulator B (Inclusive)	$B + M \Rightarrow B$	B	IMM DIR EXT IND,X IND,Y	CA DA FA EA EA	ii dd hh ll ff ff	2 3 4 4 5	—	—	—	—	Δ	Δ	0	—
PSHA	Push A onto Stack	$A \Rightarrow \text{Stk}, \text{SP} = \text{SP} - 1$	A	INH	36	—	3	—	—	—	—	—	—	—	—
PSHB	Push B onto Stack	$B \Rightarrow \text{Stk}, \text{SP} = \text{SP} - 1$	B	INH	37	—	3	—	—	—	—	—	—	—	—
PSHX	Push X onto Stack (Lo First)	$\text{IX} \Rightarrow \text{Stk}, \text{SP} = \text{SP} - 2$		INH	3C	—	4	—	—	—	—	—	—	—	—
PSHY	Push Y onto Stack (Lo First)	$\text{IY} \Rightarrow \text{Stk}, \text{SP} = \text{SP} - 2$		INH	18 3C	—	5	—	—	—	—	—	—	—	—
PULA	Pull A from Stack	$\text{SP} = \text{SP} + 1, A \Leftarrow \text{Stk}$	A	INH	32	—	4	—	—	—	—	—	—	—	—
PULB	Pull B from Stack	$\text{SP} = \text{SP} + 1, B \Leftarrow \text{Stk}$	B	INH	33	—	4	—	—	—	—	—	—	—	—
PULX	Pull X From Stack (Hi First)	$\text{SP} = \text{SP} + 2, \text{IX} \Leftarrow \text{Stk}$		INH	38	—	5	—	—	—	—	—	—	—	—
PULY	Pull Y from Stack (Hi First)	$\text{SP} = \text{SP} + 2, \text{IY} \Leftarrow \text{Stk}$		INH	18 38	—	6	—	—	—	—	—	—	—	—
ROL (opr)	Rotate Left			EXT IND,X IND,Y	79 69 69	hh ll ff ff	6 6 7	—	—	—	—	Δ	Δ	Δ	Δ
ROLA	Rotate Left A		A	INH	49	—	2	—	—	—	—	Δ	Δ	Δ	Δ
ROLB	Rotate Left B		B	INH	59	—	2	—	—	—	—	Δ	Δ	Δ	Δ
ROR (opr)	Rotate Right			EXT IND,X IND,Y	76 66 66	hh ll ff ff	6 6 7	—	—	—	—	Δ	Δ	Δ	Δ
RORA	Rotate Right A		A	INH	46	—	2	—	—	—	—	Δ	Δ	Δ	Δ
RORB	Rotate Right B		B	INH	56	—	2	—	—	—	—	Δ	Δ	Δ	Δ
RTI	Return from Interrupt	See Figure 3-2		INH	3B	—	12	Δ	↓	Δ	Δ	Δ	Δ	Δ	Δ
RTS	Return from Subroutine	See Figure 3-2		INH	39	—	5	—	—	—	—	—	—	—	—
SBA	Subtract B from A	$A - B \Rightarrow A$		INH	10	—	2	—	—	—	—	Δ	Δ	Δ	Δ

Freescale Semiconductor, Inc.

**Table 3-2 Instruction Set (Sheet 6 of 7)**

Mnemonic	Operation	Description	Addressing Mode	Instruction			Condition Codes							
				Opcode	Operand	Cycles	S	X	H	I	N	Z	V	C
SBCA (opr)	Subtract with Carry from A	$A - M - C \Rightarrow A$	A IMM	82	ii	2	—	—	—	—	$\Delta$	$\Delta$	$\Delta$	$\Delta$
			A DIR	92	dd	3								
			A EXT	B2	hh ll	4								
			A IND,X	A2	ff	4								
			A IND,Y	A2	ff	5								
SBCB (opr)	Subtract with Carry from B	$B - M - C \Rightarrow B$	B IMM	C2	ii	2	—	—	—	—	$\Delta$	$\Delta$	$\Delta$	$\Delta$
			B DIR	D2	dd	3								
			B EXT	F2	hh ll	4								
			B IND,X	E2	ff	4								
			B IND,Y	E2	ff	5								
SEC	Set Carry	$1 \Rightarrow C$	INH	0D	—	2	—	—	—	—	—	—	—	1
SEI	Set Interrupt Mask	$1 \Rightarrow I$	INH	0F	—	2	—	—	—	1	—	—	—	—
SEV	Set Overflow Flag	$1 \Rightarrow V$	INH	0B	—	2	—	—	—	—	—	—	1	—
STAA (opr)	Store Accumulator A	$A \Rightarrow M$	A DIR	97	dd	3	—	—	—	—	$\Delta$	$\Delta$	0	—
			A EXT	B7	hh ll	4								
			A IND,X	A7	ff	4								
			A IND,Y	A7	ff	5								
STAB (opr)	Store Accumulator B	$B \Rightarrow M$	B DIR	D7	dd	3	—	—	—	—	$\Delta$	$\Delta$	0	—
			B EXT	F7	hh ll	4								
			B IND,X	E7	ff	4								
			B IND,Y	E7	ff	5								
STD (opr)	Store Accumulator D	$A \Rightarrow M, B \Rightarrow M + 1$	DIR	DD	dd	4	—	—	—	—	$\Delta$	$\Delta$	0	—
			EXT	FD	hh ll	5								
			IND,X	ED	ff	5								
			IND,Y	ED	ff	6								
STOP	Stop Internal Clocks	—	INH	CF	—	2	—	—	—	—	—	—	—	—
STS (opr)	Store Stack Pointer	$SP \Rightarrow M : M + 1$	DIR	9F	dd	4	—	—	—	—	$\Delta$	$\Delta$	0	—
			EXT	BF	hh ll	5								
			IND,X	AF	ff	5								
			IND,Y	AF	ff	6								
STX (opr)	Store Index Register X	$IX \Rightarrow M : M + 1$	DIR	DF	dd	4	—	—	—	—	$\Delta$	$\Delta$	0	—
			EXT	FF	hh ll	5								
			IND,X	EF	ff	5								
			IND,Y	EF	ff	6								
STY (opr)	Store Index Register Y	$IY \Rightarrow M : M + 1$	DIR	18	DF	5	—	—	—	—	$\Delta$	$\Delta$	0	—
			EXT	18	FF	6								
			IND,X	1A	EF	6								
			IND,Y	18	EF	6								
SUBA (opr)	Subtract Memory from A	$A - M \Rightarrow A$	A IMM	80	ii	2	—	—	—	—	$\Delta$	$\Delta$	$\Delta$	$\Delta$
			A DIR	90	dd	3								
			A EXT	B0	hh ll	4								
			A IND,X	A0	ff	4								
			A IND,Y	A0	ff	5								
SUBB (opr)	Subtract Memory from B	$B - M \Rightarrow B$	A IMM	C0	ii	2	—	—	—	—	$\Delta$	$\Delta$	$\Delta$	$\Delta$
			A DIR	D0	dd	3								
			A EXT	F0	hh ll	4								
			A IND,X	E0	ff	4								
			A IND,Y	E0	ff	5								
SUBD (opr)	Subtract Memory from D	$D - M : M + 1 \Rightarrow D$	IMM	83	jj kk	4	—	—	—	—	$\Delta$	$\Delta$	$\Delta$	$\Delta$
			DIR	93	dd	5								
			EXT	B3	hh ll	6								
			IND,X	A3	ff	6								
			IND,Y	A3	ff	7								
SWI	Software Interrupt	See Figure 3-2	INH	3F	—	14	—	—	—	1	—	—	—	—
TAB	Transfer A to B	$A \Rightarrow B$	INH	16	—	2	—	—	—	—	$\Delta$	$\Delta$	0	—
TAP	Transfer A to CC Register	$A \Rightarrow CCR$	INH	06	—	2	$\Delta$	$\downarrow$	$\Delta$	$\Delta$	$\Delta$	$\Delta$	$\Delta$	$\Delta$
TBA	Transfer B to A	$B \Rightarrow A$	INH	17	—	2	—	—	—	—	$\Delta$	$\Delta$	0	—
TEST	TEST (Only in Test Modes)	Address Bus Counts	INH	00	—	*	—	—	—	—	—	—	—	—
TPA	Transfer CC Register to A	$CCR \Rightarrow A$	INH	07	—	2	—	—	—	—	—	—	—	—
TST (opr)	Test for Zero or Minus	$M - 0$	EXT	7D	hh ll	6	—	—	—	—	$\Delta$	$\Delta$	0	0
			IND,X	6D	ff	6								
			IND,Y	6D	ff	7								
TSTA	Test A for Zero or Minus	$A - 0$	A INH	4D	—	2	—	—	—	—	$\Delta$	$\Delta$	0	0
TSTB	Test B for Zero or Minus	$B - 0$	B INH	5D	—	2	—	—	—	—	$\Delta$	$\Delta$	0	0

Freescale Semiconductor, Inc.

**CENTRAL PROCESSING UNIT**

**Table 3-2 Instruction Set (Sheet 7 of 7)**

Mnemonic	Operation	Description	Addressing Mode	Instruction			Condition Codes							
				Opcode	Operand	Cycles	S	X	H	I	N	Z	V	C
TSX	Transfer Stack Pointer to X	SP + 1 ⇒ IX	INH	30	—	3	—	—	—	—	—	—	—	—
TSY	Transfer Stack Pointer to Y	SP + 1 ⇒ IY	INH	18 30	—	4	—	—	—	—	—	—	—	—
TXS	Transfer X to Stack Pointer	IX – 1 ⇒ SP	INH	35	—	3	—	—	—	—	—	—	—	—
TYS	Transfer Y to Stack Pointer	IY – 1 ⇒ SP	INH	18 35	—	4	—	—	—	—	—	—	—	—
WAI	Wait for Interrupt	Stack Regs & WAIT	INH	3E	—	**	—	—	—	—	—	—	—	—
XGDX	Exchange D with X	IX ⇒ D, D ⇒ IX	INH	8F	—	3	—	—	—	—	—	—	—	—
XGDY	Exchange D with Y	IY ⇒ D, D ⇒ IY	INH	18 8F	—	4	—	—	—	—	—	—	—	—

## SECTION 4 OPERATING MODES AND ON-CHIP MEMORY

This section contains information about the modes that define MC68HC11D3 operating conditions, and about the on-chip memory that allows the MCU to be configured for various applications.

### 4.1 Operating Modes

The values of the mode select inputs MODB and MODA during reset determine the operating mode. Single chip and expanded multiplexed are the normal modes. With single-chip mode only on-board memory is available. Expanded multiplexed mode, however, allows access to external memory. Each of these two normal modes is paired with a special mode. Bootstrap, a variation of the single-chip mode, is a special mode that executes a bootloader program in an internal bootstrap ROM. Test is a special mode that allows privileged access to internal resources.

#### 4.1.1 Single-Chip Mode

In single-chip mode, ports B and C are available for general-purpose parallel I/O. In expanded multiplexed mode the MCU can access a 64 Kbyte address space. The total address space includes the same on-chip memory addresses used for single-chip mode plus external memory and peripheral devices.

#### 4.1.2 Expanded Multiplexed Mode

Expanded memory access is achieved by providing multiplexed external data and address buses on two of the M68HC11 ports; therefore only 18 pins are needed for an 8-bit data bus, a 16-bit address bus and two bus control lines. Port B is designated for ADDR[15:8], while port C is multiplexed ADDR[7:0]/DATA[7:0]. The address,  $R/\bar{W}$ , and AS signals are active and valid for all bus cycles including accesses to internal memory locations. Refer to **Figure 4-1**, which illustrates a recommended method of demultiplexing low order addresses from data at port C.

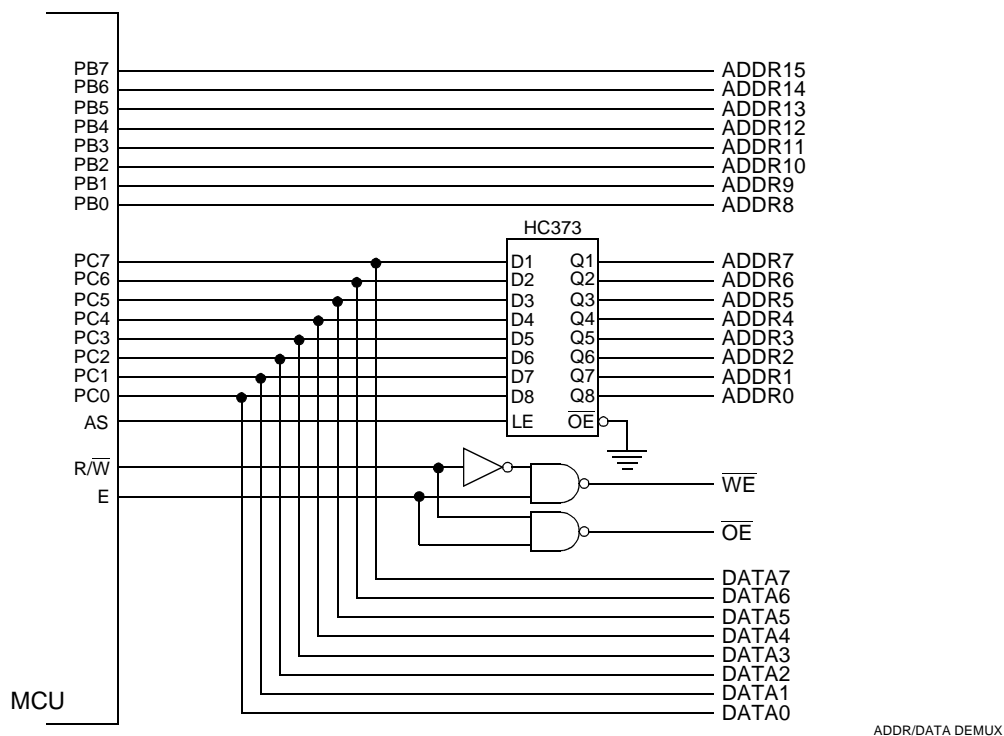

Figure 4-1 Address/Data Demultiplexing

### 4.1.3 Special Test Mode

Special test, a variation of the expanded multiplexed mode, is primarily used during Motorola's internal production testing; however, it is accessible for programming the CONFIG register, and supporting emulation and debugging during development.

### 4.1.4 Bootstrap Mode

When the MCU is reset in special bootstrap mode, a small amount of on-chip ROM is enabled at address \$BF00-\$BFFF. The ROM contains a bootloader program and a special set of interrupt and reset vectors. The MCU fetches the reset vector, then executes the bootloader.

For normal use of the bootloader program, send \$FF to the SCI receiver at either E clock ÷16, or E clock ÷104 (1200 baud for E clock equals 2 MHz). Then download up to 192 bytes of program data, which is put into RAM starting at \$0040. These characters are echoed through the transmitter. When loading is complete, the program jumps to location \$0040 and begins executing the code. The bootloader program ends the download after 192 bytes, or when the received data line is idle for at least four character times. Use of an external pullup resistor is required when using the SCI transmitter pin because port D pins are configured for wired-OR operation by the bootloader. In bootstrap mode, the interrupt vectors are directed to RAM. This allows the use of interrupts through a jump table. Refer to Freescale application note AN1060, *MC68HC11 Bootstrap Mode*.

### 4.2 Memory Map

The operating mode determines memory mapping and whether memory is addressed on- or off-chip. Refer to **Figure 4-2**, which illustrates the memory maps for each of the four modes of operation. Memory locations for on-chip resources are the same for both expanded multiplexed and single-chip modes. 192-byte RAM is mapped to \$0040 after reset. It can be placed at any other 4K boundary (\$x040) by writing an appropriate value to the INIT register. The 64-byte register block is mapped to \$0000 after reset and can also be placed at any 4K boundary (\$x000) by writing an appropriate value to the INIT register. Refer to **Table 4-1**, which details the MCU register and control bit assignments.

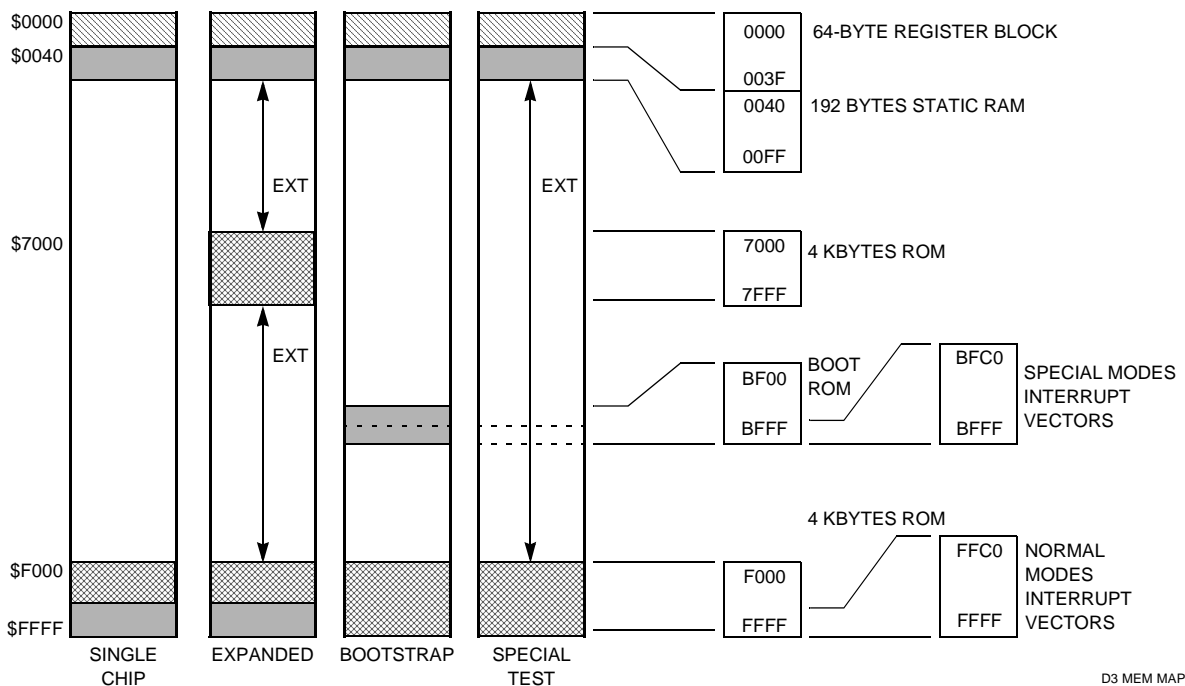

**Figure 4-2 MC68HC11D3 Memory Map**

**Table 4-1 Register and Control Bit Assignments**

	Bit 7	6	5	4	3	2	1	Bit 0	
\$0000	PA7	PA6	PA5	PA4	PA3	PA2	PA1	PA0	PORTA
\$0001									Reserved
\$0002			CWOM						PIOC
\$0003	PC7	PC6	PC5	PC4	PC3	PC2	PC1	PC0	PORTC
\$0004	PB7	PB6	PB5	PB4	PB3	PB2	PB1	PB0	PORTB
\$0005									Reserved
\$0006	DDB7	DDB6	DDB5	DDB4	DDB3	DDB2	DDB1	DDB0	DDRB
\$0007	DDC7	DDC6	DDC5	DDC4	DDC3	DDC2	DDC1	DDC0	DDRC
\$0008	PD7	PD6	PD5	PD4	PD3	PD2	PD1	PD0	PORTD
\$0009	DDD7	DDD6	DDD5	DDD4	DDD3	DDD2	DDD1	DDD0	DDRD
\$000A									Reserved
\$000B	FOC1	FOC2	FOC3	FOC4	FOC5	0	0	0	CFORC
\$000C	OC1M7	OC1M6	OC1M5	OC1M4	OC1M3	0	0	0	OC1M
\$000D	OC1D7	OC1D6	OC1D5	OC1D4	OC1D3	0	0	0	OC1D
\$000E	Bit 15	14	13	12	11	10	9	Bit 8	TCNT (High)
\$000F	Bit 7	6	5	4	3	2	1	Bit 0	TCNT (Low)
\$0010	Bit 15	14	13	12	11	10	9	Bit 8	TIC1 (High)
\$0011	Bit 7	6	5	4	3	2	1	Bit 0	TIC1 (Low)
\$0012	Bit 15	14	13	12	11	10	9	Bit 8	TIC2 (High)
\$0013	Bit 7	6	5	4	3	2	1	Bit 0	TIC2 (Low)
\$0014	Bit 15	14	13	12	11	10	9	Bit 8	TIC3 (High)
\$0015	Bit 7	6	5	4	3	2	1	Bit 0	TIC3 (Low)
\$0016	Bit 15	14	13	12	11	10	9	Bit 8	TOC1(High)
\$0017	Bit 7	6	5	4	3	2	1	Bit 0	TOC1 (Low)
\$0018	Bit 15	14	13	12	11	10	9	Bit 8	TOC2 (High)
\$0019	Bit 7	6	5	4	3	2	1	Bit 0	TOC2 (Low)
\$001A	Bit 15	14	13	12	11	10	9	Bit 8	TOC3 (High)
\$001B	Bit 7	6	5	4	3	2	1	Bit 0	TOC3 (Low)
\$001C	Bit 15	14	13	12	11	10	9	Bit 8	TOC4 (High)
\$001D	Bit 7	6	5	4	3	2	1	Bit 0	TOC4 (Low)
\$0023	OC1F	OC2F	OC3F	OC4F	I4/O5F	IC1F	IC2F	IC3F	TFLG1
\$0024	TOI	RTII	PAOVI	PAII	0	0	PR1	PR0	TMSK2
\$0025	TOF	RTIF	PAOVF	PAIF	0	0	0	0	TFLG2
\$0026	DDRA7	PAEN	PAMOD	PEDGE	DDRA3	I4/O5	RTR1	RTR0	PACTL
\$0027	Bit 7	6	5	4	3	2	1	Bit 0	PACNT
\$0028	SPIE	SPE	DWOM	MSTR	CPOL	CPHA	SPR1	SPR0	SPCR
\$0029	SPIF	WCOL	0	MODF	0	0	0	0	SPSR
\$002A	Bit 7	6	5	4	3	2	1	Bit 0	SPDR

**Table 4-1 Register and Control Bit Assignments (Continued)**

	Bit 7	6	5	4	3	2	1	Bit 0	
\$002B	TCLR	0	SCP1	SCP0	RCKB	SCR2	SCR1	SCR0	BAUD
\$002C	R8	T8	0	M	WAKE	0	0	0	SCCR1
\$002D	TIE	TCIE	RIE	ILIE	TE	RE	RWU	SBK	SCCR2
\$002E	TDRE	TC	RDRF	IDLE	OR	NF	FE	0	SCSR
\$002F	R7/T7	R6/T6	R5/T5	R4/T4	R3/T3	R2/T2	R1/T1	R0/T0	SCDR
\$0030									Reserved
to									
\$0038									Reserved
\$0039	0	0	IRQE	DLY	CME	0	CR1	CR0	OPTION
\$003A	Bit 7	6	5	4	3	2	1	Bit 0	COPRST
\$003B									Reserved
\$003C	RBOOT	SMOD	MDA	IRVNE	PSEL3	PSEL2	PSEL1	PSEL0	HPRIO
\$003D	RAM3	RAM2	RAM1	RAM0	REG3	REG2	REG1	REG0	INIT
\$003E	TILOP	0	OCCR	CBYP	DISR	FCM	FCOP	0	TEST1
\$003F	0	0	0	0	0	NOCOP	ROMON	0	CONFIG

The bootloader program is contained in the 192-byte bootstrap ROM. This ROM, which appears as internal memory space at locations \$BF40–\$BFFF, is enabled only if the MCU is reset in special bootstrap mode.

Memory locations are the same for expanded multiplexed and single-chip modes, except for ROM in expanded mode and the bootloader ROM in special bootstrap mode. The on-board 192-byte RAM is initially located at \$0040 after reset, but can be placed at any other 4K boundary (\$x040) by writing an appropriate value to the INIT register.

The 4 Kbyte ROM is located at \$F000 through \$FFFF in all modes except expanded multiplexed, in which it is located at \$7000. ROM can be located at \$F000 in expanded multiplexed by entering single-chip mode out of reset and setting the MDA bit in the HPRIO register to 1, thereby entering expanded mode from internal ROM. Disable ROM by clearing the ROMON bit in the CONFIG register.

Hardware priority is built into RAM and I/O remapping. Registers and RAM have priority over ROM. In the event of conflicts, the higher priority resource takes precedence.

The 192 bytes of fully static RAM store instructions, variables, and temporary data. The direct addressing mode can access RAM locations using a one-byte address operand, saving program memory space and execution time, depending on the application. RAM contents are preserved during periods of processor inactivity by two methods, both of which reduce power consumption.

In the software-based STOP mode, the clocks are stopped while V<sub>DD</sub> powers the MCU. Because power supply current is directly related to operating frequency in CMOS integrated circuits, only a very small amount of leakage exists when the clocks are stopped.

In the second method, the MODB/ $V_{STBY}$  pin can supply RAM power from a battery backup or from a second power supply, as shown in **Figure 4-3**. Using the MODB/ $V_{STBY}$  pin may require external hardware, but can be justified when a significant amount of external circuitry is operating from  $V_{DD}$ . If  $V_{STBY}$  is used to maintain RAM contents, reset must be held low whenever  $V_{DD}$  is below normal operating level. Refer to **SECTION 5 RESETS AND INTERRUPTS**.

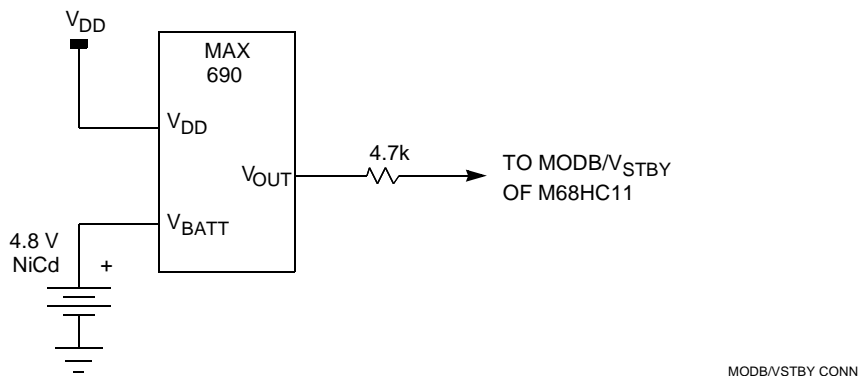

**Figure 4-3 RAM Standby MODB/ $V_{STBY}$  Connections**

**4.2.1 Priority and Mode Select Register**

The four operating modes are selected with the logic states of the mode A (MODA) and mode B (MODB) pins during reset. The MODA and MODB logic levels determine the logic state of the special mode (SMOD) and mode A (MDA) control bits in the HPRIO register.

After reset is released, the mode select pins no longer influence the MCU operating mode. For single-chip mode, the MODA pin is connected to a logic zero. For expanded mode, MODA is normally connected to  $V_{DD}$  through a pull-up resistor of 4.7 k $\Omega$ . The MODA pin also functions as the load instruction register ( $\overline{LIR}$ ) pin when the MCU is not in reset. The open drain active low  $\overline{LIR}$  output pin drives low during the first E cycle of each instruction. The MODB pin also functions as standby power input,  $V_{STBY}$ , which maintains RAM contents in the absence of  $V_{DD}$ . Refer to **Table 4-2** for information about hardware mode selection.

**Table 4-2 Hardware Mode Select Summary**

Inputs		Mode	Latched at Reset		
MODB	MODA		RBOOT	SMOD	MDA
1	0	Single-Chip	0	0	0
1	1	Expanded Multiplexed	0	0	1
0	0	Special Bootstrap	1	1	0
0	1	Special Test	0	1	1

**HPRIO** — Highest Priority I-Bit Interrupt and Miscellaneous

**\$003C**

	Bit 7	6	5	4	3	2	1	Bit 0
	RBOOT	SMOD	MDA	IRVNE	PSEL3	PSEL2	PSEL1	PSEL0
RESET:	—	—	—	—	0	1	0	1

The values of the RBOOT, SMOD, IRVNE, and MDA at reset depend on the mode during initialization. Refer to **Table 4-2**.

**RBOOT** — Read Bootstrap ROM

Has meaning only when the SMOD bit is a one (special bootstrap mode or special test mode). At all other times this bit is clear and cannot be written.

- 0 = Bootloader ROM disabled and not in map
- 1 = Bootloader ROM enabled and located in map at \$BF40–\$BFFF

**SMOD** — Special Mode Select

This bit reflects the inverse of the MODB input pin at the rising edge of reset. It is set if the MODB input pin is low during reset. If MODB is high during reset, it is cleared. SMOD can be cleared under software control from the special modes, thus changing the operating mode of the MCU. SMOD can never be set by software.

- 0 = Normal mode variation in effect
- 1 = Special mode variation in effect

**MDA** — Mode Select A

The mode select A bit reflects the status of the MODA input pin at the rising edge of reset. While the SMOD bit is set (special bootstrap or special test mode in effect), the MDA bit can be written, thus changing the operating mode of the MCU. When the SMOD bit is clear, the MODA bit is read-only and the operating mode cannot be changed without going through a reset sequence.

- 0 = Normal single-chip or special bootstrap mode in effect
- 1 = Normal expanded or special test mode in effect

**IRVNE** — Internal Read Visibility/Not E

The IRVNE control bit allows internal read accesses to be available on the external data bus during factory testing or emulation. If this capability is used for other purposes, bus conflicts can occur because the bidirectional data bus is driven out during a read of internal addresses, even though the  $\overline{R/W}$  line suggests a high impedance read mode.

- 0 = No internal read visibility on external bus
- 1 = Internal read data driven out data bus

In single-chip modes, this bit determines whether the E clock drives out of the chip.

- 0 = E driven out
- 1 = E pin driven low

Mode	IRVNE Out of Reset	E Clock Out of Reset	IRV Out of Reset	IRVNE Affects Only
Single-Chip	0	On	Off	E
Expanded	0	On	Off	IRV
Boot	0	On	Off	E
Special Test	1	On	On	IRV

**PSEL[3:0] — Priority Select Bits**

Refer to **SECTION 5 RESETS AND INTERRUPTS**.

**4.2.2 System Initialization**

Registers and bits that control initialization and the basic configuration of the MCU are protected against writes except under special circumstances. The protection mechanism, overridden in special operating modes, permits writing these bits only within the first 64 bus cycles after any reset, and then only once after each reset. If the MCU is going to be changed to a normal mode after being reset in a special mode, write to the protected registers before writing the SMOD control bit to zero.

**4.2.2.1 CONFIG Register**

The CONFIG register consists of static latches that control the startup configuration of the MCU. CONFIG is writable only once in expanded and single-chip modes (SMOD = 0). In these modes, the COP watchdog timer is enabled out of reset.

**CONFIG — System Configuration**

**\$003F**

	Bit 7	6	5	4	3	2	1	Bit 0
	0	0	0	0	0	NOCOP	ROMON	0
RESET:	0	0	0	0	0	—	—	0

Bits [7:3] and 0 — Not implemented  
Always read zero

**NOCOP — COP System Disable**

This bit is cleared out of reset in normal modes (COP enabled). Refer to **SECTION 5 RESETS AND INTERRUPTS**.

- 0 = COP system enabled
- 1 = COP system disabled

**ROMON — ROM Enable**

In all modes, ROMON is forced to one out of reset. Writable once in normal modes and writable at any time in special modes.

- 0 = ROM removed from the memory map
- 1 = ROM present in the memory map

**NOTE**

In expanded mode, ROM is located at \$7000–\$7FFF out of reset. In all other modes, ROM is located at \$F000–\$FFFF.

**4.2.2.2 INIT Register**

The internal registers used to control the operation of the MCU can be relocated on 4K boundaries within the memory space with the use of INIT. This 8-bit special-purpose register can change the default locations of the RAM and control registers within the MCU memory map. It can be written to only once within the first 64 E-clock cycles after a reset, and then it becomes a read-only register.

**INIT — RAM and I/O Mapping Register**

**\$003D**

	Bit 7	6	5	4	3	2	1	Bit 0
	RAM3	RAM2	RAM1	RAM0	REG3	REG2	REG1	REG0
RESET:	0	0	0	0	0	0	0	1

**RAM[3:0] — RAM Map Position**

These four bits, which specify the upper hexadecimal digit of the RAM address, control position of RAM in the memory map. RAM can be positioned at the beginning of any 4K page in the memory map. It is initialized to address \$0040 out of reset. Refer to **Table 4-3**.

**REG[3:0] — 64-Byte Register Block Position**

These four bits specify the upper hexadecimal digit of the address for the 64-byte block of internal registers. The register block, positioned at the beginning of any 4K page in the memory map, is initialized to address \$0000 out of reset. Refer to **Table 4-4**.

**Table 4-3 RAM Mapping**

RAM[3:0]	Address
0000	\$0040–\$00FF
0001	\$1040–\$10FF
0010	\$2040–\$20FF
0011	\$3040–\$30FF
0100	\$4040–\$40FF
0101	\$5040–\$50FF
0110	\$6040–\$60FF
0111	\$7040–\$70FF
1000	\$8040–\$80FF
1001	\$9040–\$90FF
1010	\$A040–\$A0FF
1011	\$B040–\$B0FF
1100	\$C040–\$C0FF
1101	\$D040–\$D0FF
1110	\$E040–\$E0FF
1111	\$F040–\$F0FF

**Table 4-4 Register Mapping**

REG[3:0]	Address
0000	\$0000–\$003F
0001	\$1000–\$103F
0010	\$2000–\$203F
0011	\$3000–\$303F
0100	\$4000–\$403F
0101	\$5000–\$503F
0110	\$6000–\$603F
0111	\$7000–\$703F
1000	\$8000–\$803F
1001	\$9000–\$903F
1010	\$A000–\$A03F
1011	\$B000–\$B03F
1100	\$C000–\$C03F
1101	\$D000–\$D03F
1110	\$E000–\$E03F
1111	\$F000–\$F03F

**4.2.2.3 OPTION Register**

The 8-bit special-purpose OPTION register sets internal system configuration options during initialization. The time protected control bits, IRQE, DLY, and CR[1:0] can be written to only once after a reset and then they become read-only. This minimizes the possibility of any accidental changes to the system configuration.

**OPTION — System Configuration Options**

**\$0039**

	Bit 7	6	5	4	3	2	1	Bit 0
	0	0	IRQE*	DLY*	CME	0	CR1*	CR0*
RESET:	0	0	0	1	0	0	0	0

\*Can be written only once in first 64 cycles out of reset in normal modes, or at any time in special modes

Bits [7:6] and 2 — Not implemented  
Always read zero

**IRQE —  $\overline{\text{IRQ}}$  Select Edge Sensitive only**

- 0 =  $\overline{\text{IRQ}}$  is configured for level sensitive operation
- 1 =  $\overline{\text{IRQ}}$  is configured for edge sensitive only operation

**DLY — Enable Oscillator Startup Delay**

- 0 = The oscillator startup delay coming out of STOP is bypassed and the MCU resumes processing within about four bus cycles.
- 1 = A delay of approximately 4000 E-clock cycles is imposed as the MCU is started up from the STOP power-saving mode. This delay allows the crystal oscillator to stabilize.

**CME — Clock Monitor Enable**

Refer to **SECTION 5 RESETS AND INTERRUPTS**.

**CR[1:0] — COP Timer Rate Select Bits**

The internal E clock is first divided by  $2^{15}$  before it enters the COP watchdog system. These control bits determine a scaling factor for the watchdog timer. Refer to **SECTION 5 RESETS AND INTERRUPTS**.

## SECTION 5 RESETS AND INTERRUPTS

Resets and interrupt operations load the program counter with a vector that points to a new location from which instructions are to be fetched. A reset immediately stops execution of the current instruction and forces the program counter to a known starting address. Internal registers and control bits are initialized so the MCU can resume executing instructions. An interrupt temporarily suspends normal program execution while an interrupt service routine is being executed. After an interrupt has been serviced, the main program resumes as if there had been no interruption.

### 5.1 Resets

There are four possible sources of reset. Power-on reset (POR) and external reset share the normal reset vector. The computer operating properly (COP) system and the clock monitor each has its own vector.

#### 5.1.1 Power-On Reset

A positive transition on  $V_{DD}$  generates a power-on reset (POR), which is used only for power-up conditions. POR cannot be used to detect drops in power supply voltages. A 4064  $t_{CYC}$  (internal clock cycle) delay after the oscillator becomes active allows the clock generator to stabilize. If  $\overline{RESET}$  is at logical zero at the end of 4064  $t_{CYC}$ , the CPU remains in the reset condition until goes to logical one.

It is important to protect the MCU during power transitions. Most M68HC11 systems need an external circuit that holds the  $\overline{RESET}$  pin low whenever  $V_{DD}$  is below the minimum operating level. This external voltage level detector, or other external reset circuits, are the usual source of reset in a system. The POR circuit only initializes internal circuitry during cold starts. Refer to **Figure 2-3**.

#### 5.1.2 External Reset ( $\overline{RESET}$ )

The CPU distinguishes between internal and external reset conditions by sensing whether the reset pin rises to a logic one in less than two E-clock cycles after an internal device releases reset. When a reset condition is sensed, the  $\overline{RESET}$  pin is driven low by an internal device for four E-clock cycles, then released. Two E-clock cycles later it is sampled. If the pin is still held low, the CPU assumes that an external reset has occurred. If the pin is high, it indicates that the reset was initiated internally by either the COP system or the clock monitor. It is not advisable to connect an external resistor capacitor (RC) power-up delay circuit to the reset pin of M68HC11 devices because the circuit charge time constant can cause the device to misinterpret the type of reset that occurred.

#### 5.1.3 COP Reset

The MCU includes a COP system to help protect against software failures. When the

COP is enabled, the software is responsible for keeping a free-running watchdog timer from timing out. When the software is no longer being executed in the intended sequence, a system reset is initiated.

The state of the NOCOP bit in the CONFIG register determines whether the COP system is enabled or disabled. In normal modes, COP is enabled out of reset and does not depend on software action. To disable the COP system, set the NOCOP bit in the CONFIG register. In the special test and bootstrap operating modes, the COP system is initially inhibited by the disable resets (DISR) control bit in the TEST1 register. The DISR bit can subsequently be written to zero to enable COP resets.

The COP timer rate control bits CR[1:0] in the OPTION register determine the COP time-out period. The system E clock is divided by  $2^{15}$  and then further scaled by a factor shown in **Table 5-1**. After reset, these bits are zero, which selects the fastest time-out period. In normal operating modes, these bits can only be written once within 64 bus cycles after reset.

**Table 5-1 COP Time-out**

CR[1:0]	Divide E/2 <sup>15</sup> By	XTAL = 4.0 MHz Time-out -0/+32.8 ms	XTAL = 8.0 MHz Time-out -0/+16.4 ms	XTAL = 12.0 MHz Time-out -0/+10.9 ms
0 0	1	32.768 ms	16.384 ms	10.923 ms
0 1	4	131.072 ms	65.536 ms	43.691 ms
1 0	16	524.288 ms	262.140 ms	174.76 ms
1 1	64	2.097 sec	1.049 sec	699.05 ms
	E =	1.0 MHz	2.0 MHz	3.0 MHz

**COPRST — Am/Reset COP Timer Circuitry**

**\$003A**

	Bit 7	6	5	4	3	2	1	Bit 0
	7	6	5	4	3	2	1	0
RESET:	0	0	0	0	0	0	0	0

Complete the following reset sequence to service the COP timer. Write \$55 to COPRST to arm the COP timer clearing mechanism. Then write \$AA to COPRST to clear the COP timer. Performing instructions between these two steps is possible as long as both steps are completed in the correct sequence before the timer times out.

**5.1.4 Clock Monitor Reset**

The clock monitor circuit is based on an internal RC time delay. If no MCU clock edges are detected within this RC time delay, the clock monitor can optionally generate a system reset. The clock monitor function is enabled or disabled by the CME control bit in the OPTION register. The presence of a time-out is determined by the RC delay, which allows the clock monitor to operate without any MCU clocks.

Clock monitor is used as a backup for the COP system. Because the COP needs a clock to function, it is disabled when the clocks stop. Therefore, the clock monitor system can detect clock failures not detected by the COP system.

Semiconductor wafer processing causes variations of the RC time-out values between individual devices. An E-clock frequency below 10 kHz is detected as a clock monitor error. An E-clock frequency of 200 kHz or more prevents clock monitor errors. Using the clock monitor function when the E clock is below 200 kHz is not recommended.

Special considerations are needed when a STOP instruction is executed and the clock monitor is enabled. Because the STOP function causes the clocks to be halted, the clock monitor function generates a reset sequence if it is enabled at the time the STOP mode was initiated. Before executing a STOP instruction, clear the CME bit in the OPTION register to zero to disable the clock monitor. After recovery from STOP, set the CME bit to logic one to enable the clock monitor.

### 5.1.5 Option Register

**OPTION** — System Configuration Options **\$0039**

	Bit 7	6	5	4	3	2	1	Bit 0
	0	0	IRQE*	DLY*	CME	0	CR1*	CR0*
RESET:	0	0	0	1	0	0	0	0

\*Can be written only once in first 64 cycles out of reset in normal modes, or at any time in special modes.

Bits [7:6] and 2 — Not implemented  
Always read zero

**IRQE** — Configure  $\overline{IRQ}$  for Edge Sensitive Only Operation

This bit can be written only once during the first 64 E-clock cycles after reset in normal modes.

- 0 = Low level recognition
- 1 = Falling edge recognition

**DLY** — Enable Oscillator Startup Delay

This bit is set during reset and can be written only once during the first 64 E-clock cycles after reset in normal modes. If an external clock source rather than a crystal is used, the stabilization delay can be inhibited because the clock source is assumed to be stable.

- 0 = No stabilization delay on exit from STOP
- 1 = Stabilization delay enabled on exit from STOP

**CME** — Clock Monitor Enable

This control bit can be read or written at any time and controls whether or not the internal clock monitor circuit triggers a reset sequence when the system clock is slow or absent. When it is clear, the clock monitor circuit is disabled. When it is set, the clock monitor circuit is enabled. Reset clears the CME bit.

**CR[1:0]** — COP Timer Rate Select

These control bits determine a scaling factor for the watchdog timer.

### 5.1.6 CONFIG Register

**CONFIG** — Configuration Control Register **\$003F**

	Bit 7	6	5	4	3	2	1	Bit 0
	0	0	0	0	0	NOCOP	ROMON	0
RESET:	0	0	0	0	0	—	—	0

Bits [7:4] and 0 — Not implemented  
Always read zero

#### NOCOP — COP System Disable

This bit is cleared out of reset in normal modes, enabling the COP system. It is set out of reset in special modes. NOCOP is writable once in normal modes and at any time in special modes.

0 = The COP system is enabled as the MCU comes out of reset.

1 = The COP system is disabled and does not generate system resets.

#### ROMON — Enable On-Chip ROM

Refer to **SECTION 4 OPERATING MODES AND ON-CHIP MEMORY**.

### 5.2 Effects of Reset

When a reset condition is recognized, the internal registers and control bits are forced to an initial state. Depending on the cause of the reset and the operating mode, the reset vector can be fetched from any of six possible locations. Refer to **Table 5-2**.

**Table 5-2 Reset Cause, Reset Vector, and Operating Mode**

Cause of Reset	Normal Mode Vector	Special Test or Bootstrap
POR or RESET Pin	\$FFFE, FFFF	\$BFFE, BFFF
Clock Monitor Failure	\$FFFC, FFFD	\$BFFC, \$BFFD
COP Watchdog Time-out	\$FFFA, FFFB	\$BFFA, BFFB

These initial states then control on-chip peripheral systems to force them to known startup states, as follows:

#### 5.2.1 CPU

After reset, the CPU fetches the restart vector from the appropriate address during the first three cycles, and begins executing instructions. The stack pointer and other CPU registers are indeterminate immediately after reset; however, the X and I interrupt mask bits in the condition code register (CCR) are set to mask any interrupt requests. Also, the S bit in the CCR is set to inhibit the STOP mode.

#### 5.2.2 Memory Map

After reset, the INIT register is initialized to \$00, putting the 192 bytes of RAM at locations \$0040 through \$00FF, and the control registers at locations \$0000 through \$003F.

### 5.2.3 Parallel I/O

When a reset occurs in expanded multiplexed operating modes, the pins used for parallel I/O are dedicated to the expansion bus. In single-chip and bootstrap modes, all ports are parallel I/O data ports. In expanded multiplexed and test modes, ports B, C, and lines DATA6/AS and DATA7/R/ $\overline{W}$  are a memory expansion bus with port B as a high-order address bus, port C as a multiplexed address and data bus, AS as the demultiplexing signal, and R/as the data bus direction control. The CWOM bit in PIOC is cleared so that port C is not in wired-OR mode. Port A, bits [0:3] and 7; and ports B, C, and D are general-purpose I/O at reset and set for input. For this reason the pins are configured as high impedance upon reset. Port A bits [4:6] are outputs, so high impedance protection is not necessary.

#### NOTE

Do not confuse pin function with the electrical state of the pin at reset. All general-purpose I/O pins configured as inputs at reset are in a high impedance state. Port data registers reflect the port's functional state at reset. The pin function is mode dependent.

### 5.2.4 Timer

During reset, the timing system is initialized to a count of \$0000. The prescaler bits are cleared, and all output compare registers are initialized to \$FFFF. All input capture registers are indeterminate after reset. The output compare 1 mask (OC1M) register is cleared so that successful OC1 compares do not affect any I/O pins. The other four output compares are configured so that they do not affect any I/O pins on successful compares. All input capture edge-detector circuits are configured for capture disabled operation. The timer overflow interrupt flag and all eight timer function interrupt flags are cleared. All nine timer interrupts are disabled because their mask bits have been cleared.

The I4/O5 bit in the PACTL register is cleared to configure the I4/O5 function as OC5; however, the OM5:OL5 control bits in the TCTL1 register are clear so OC5 does not control the PA3 pin.

### 5.2.5 Real-Time Interrupt

The real-time interrupt flag (RTIF) is cleared and automatic hardware interrupts are masked. The rate control bits are cleared after reset and can be initialized by software before the real-time interrupt (RTI) system is used. After reset, a full RTI period elapses before the first RTI interrupt.

### 5.2.6 Pulse Accumulator

The pulse accumulator system is disabled at reset so that the PAI input pin defaults to being a general-purpose input pin (PA7).

### 5.2.7 COP

The COP watchdog system is enabled if the NOCOP control bit in the CONFIG register is clear, and disabled if NOCOP is set. The COP rate is set for the shortest duration time-out.

### 5.2.8 SCI

The reset condition of the SCI system is independent of the operating mode. At reset, the SCI baud rate is indeterminate and must be established by a software write to the BAUD register. All transmit and receive interrupts are masked and both the transmitter and receiver are disabled so the port pins default to being general-purpose I/O lines. The SCI frame format is initialized to an 8-bit character size. The send break and receiver wake-up functions are disabled. The TDRE and TC status bits in the SCI status register are both set, indicating that there is no transmit data in either the transmit data register or the transmit serial shift register. The RDRF, IDLE, OR, NF, and FE receive-related status bits are cleared.

### 5.2.9 SPI

The SPI system is disabled by reset. The port pins associated with this function default to being general-purpose I/O lines.

### 5.2.10 System

The memory system is configured for normal read operation. PSEL[3:0] are initialized with the value \$0101, causing the external  $\overline{\text{IRQ}}$  pin to have the highest I-bit interrupt priority. The  $\overline{\text{IRQ}}$  pin is configured for level sensitive operation (for wired-OR systems). The RBOOT, SMOD, and MDA bits in the HPRIO register reflect the status of the MODB and MODA inputs at the rising edge of reset. The DLY control bit in OPTION is set to specify that an oscillator start-up delay is imposed upon recovery from STOP. The clock monitor system is disabled by CME equals zero.

## 5.3 Reset and Interrupt Priority

Resets and interrupts have a hardware priority that determines which reset or interrupt is serviced first when simultaneous requests occur. Any maskable interrupt can be given priority over other maskable interrupts.

The first six interrupt sources are not maskable. The priority arrangement for these sources is as follows:

1. POR or  $\overline{\text{RESET}}$  pin
2. Clock monitor reset
3. COP watchdog reset
4.  $\overline{\text{XIRQ}}$  interrupt
5. Illegal opcode interrupt
6. Software interrupt (SWI)

The maskable interrupt sources have the following priority arrangement:

1.  $\overline{\text{IRQ}}$
2. Real-time interrupt
3. Timer input capture 1
4. Timer input capture 2
5. Timer input capture 3
6. Timer output compare 1
7. Timer output compare 2
8. Timer output compare 3
9. Timer output compare 4
10. Timer input capture 4/output compare 5
11. Timer overflow
12. Pulse accumulator overflow
13. Pulse accumulator input edge
14. SPI transfer complete
15. SCI system

Any one of these interrupts can be assigned the highest maskable interrupt priority by writing the appropriate value to the PSEL bits in the HPRIO register. Otherwise, the priority arrangement remains the same. An interrupt that is assigned highest priority is still subject to global masking by the I bit in the CCR, or by any associated local bits. Interrupt vectors are not affected by priority assignment. To avoid race conditions, HPRIO can be written only while I-bit interrupts are inhibited.

### 5.3.1 Highest Priority Interrupt and Miscellaneous Register

**HPRIO** — Highest Priority I-Bit Interrupt and Miscellaneous **\$003C**

	Bit 7	6	5	4	3	2	1	Bit 0
	RBOOT	SMOD	MDA	IRVNE	PSEL3	PSEL2	PSEL1	PSEL0
RESET:	—	—	—	—	0	1	0	1

The values of the RBOOT, SMOD, IRVNE, and MDA reset bits depend on the mode during initialization. Refer to **Table 5-3**.

**RBOOT** — Read Bootstrap ROM

Has meaning only when the SMOD bit is a one (special bootstrap mode or special test mode). At all other times this bit is clear and cannot be written. Refer to **SECTION 4 OPERATING MODES AND ON-CHIP MEMORY** for more information.

**SMOD** — Special Mode Select

This bit reflects the inverse of the MODB input pin at the rising edge of reset. Refer to **SECTION 4 OPERATING MODES AND ON-CHIP MEMORY** for more information.

**MDA** — Mode Select A

The mode select A bit reflects the status of the MODA input pin at the rising edge of reset. Refer to **SECTION 4 OPERATING MODES AND ON-CHIP MEMORY** for more information.

**IRVNE** — Internal Read Visibility Enable/Not E

The IRVNE control bit allows internal read accesses to be available on the external data bus during factory testing or emulation. Refer to **SECTION 4 OPERATING MODES AND ON-CHIP MEMORY** for more information.

**PSEL[3:0] — Priority Select Bits**

These bits select one interrupt source to be elevated above all other I-bit-related sources and can be written to only while the I bit in the CCR is set (interrupts disabled).

**Table 5-3 Highest Priority Interrupt Selection**

PSEL[3:0]	Interrupt Source Promoted
0 0 0 0	Timer Overflow
0 0 0 1	Pulse Accumulator Overflow
0 0 1 0	Pulse Accumulator Input Edge
0 0 1 1	SPI Serial Transfer Complete
0 1 0 0	SCI Serial System
0 1 0 1	Reserved (Default to $\overline{\text{IRQ}}$ )
0 1 1 0	$\overline{\text{IRQ}}$ (External Pin)
0 1 1 1	Real-Time Interrupt
1 0 0 0	Timer Input Capture 1
1 0 0 1	Timer Input Capture 2
1 0 1 0	Timer Input Capture 3
1 0 1 1	Timer Output Compare 1
1 1 0 0	Timer Output Compare 2
1 1 0 1	Timer Output Compare 3
1 1 1 0	Timer Output Compare 4
1 1 1 1	Timer Input Capture 4/Output Compare 5

**5.4 Interrupts**

The MCU has 18 interrupt vectors that support 22 interrupt sources. The 19 maskable interrupts are generated by on-chip peripheral systems. These interrupts are recognized when the global interrupt mask bit (I) in the condition code register (CCR) is clear. The three non-maskable interrupt sources are illegal opcode trap, software interrupt, and  $\overline{\text{XIRQ}}$  pin. Refer to **Table 5-4**, which shows the interrupt sources and vector assignments for each source.

**Table 5-4 Interrupt and Reset Vector Assignments**

Vector Address	Interrupt Source	CCR Mask	Local Mask
FFC0, C1 — FFD4, D5 FFD6, D7	Reserved	—	—
	SCI Serial System	I Bit	—
	• SCI Transmit Complete		TCIE
	• SCI Transmit Data Register Empty		TIE
	• SCI Idle Line Detect		ILIE
	• SCI Receiver Overrun		RIE
	• SCI Receive Data Register Full		RIE
FFD8, D9	SPI Serial Transfer Complete	I Bit	SPIE
FFDA, DB	Pulse Accumulator Input Edge	I Bit	PAII
FFDC, DD	Pulse Accumulator Overflow	I Bit	PAOVI
FFDE, DF	Timer Overflow	I Bit	TOI
FFE0, E1	Timer Input Capture 4/Output Compare 5	I Bit	I4/O5I
FFE2, E3	Timer Output Compare 4	I Bit	OC4I
FFE4, E5	Timer Output Compare 3	I Bit	OC3I
FFE6, E7	Timer Output Compare 2	I Bit	OC2I
FFE8, E9	Timer Output Compare 1	I Bit	OC1I
FFEA, EB	Timer Input Capture 3	I Bit	IC3I
FFEC, ED	Timer Input Capture 2	I Bit	IC2I
FFEE, EF	Timer Input Capture 1	I Bit	IC1I
FFF0, F1	Real Time Interrupt	I Bit	RTII
FFF2, F3	$\overline{\text{IRQ}}$ (External Pin)	I Bit	None
FFF4, F5	$\overline{\text{XIRQ}}$ Pin	X Bit	None
FFF6, F7	Software Interrupt	None	None
FFF8, F9	Illegal Opcode Trap	None	None
FFFA, FB	COP Failure	None	NOCOP
FFFC, FD	Clock Monitor Fail	None	CME
FFFE, FF	RESET	None	None

### 5.4.1 Interrupt Recognition and Register Stacking

An interrupt can be recognized at any time after it is enabled by its local mask, if any, and by the global mask bit in the CCR. Once an interrupt source is recognized, the CPU responds at the completion of the instruction being executed. Interrupt latency varies according to the number of cycles required to complete the current instruction. When the CPU begins to service an interrupt, the contents of the CPU registers are pushed onto the stack in the order shown in **Table 5-5**. After the CCR value is stacked, the I bit and the X bit, if  $\overline{\text{XIRQ}}$  is pending, are set to inhibit further interrupts. The interrupt vector for the highest priority pending source is fetched, and execution continues at the address specified by the vector. At the end of the interrupt service routine, the return from interrupt instruction is executed and the saved registers are pulled from the stack in reverse order so that normal program execution can resume. Refer to **SECTION 3 CENTRAL PROCESSING UNIT** for further information.

**Table 5-5 Stacking Order on Entry to Interrupts**

Memory Location	CPU Registers
SP	PCL
SP – 1	PCH
SP – 2	IYL
SP – 3	IYH
SP – 4	IXL
SP – 5	IXH
SP – 6	ACCA
SP – 7	ACCB
SP – 8	CCR

**5.4.2 Non-Maskable Interrupt Request  $\overline{XIRQ}$**

Non-maskable interrupts are useful because they can always interrupt CPU operations. The most common use for such an interrupt is for serious system problems, such as program runaway or power failure. The  $\overline{XIRQ}$  input is an updated version of the nonmaskable  $\overline{NMI}$  input of earlier MCUs.

Upon reset, both the X bit and I bits of the CCR are set to inhibit all maskable interrupts and  $\overline{XIRQ}$ . After minimum system initialization, software can clear the X bit by a TAP instruction, enabling  $\overline{XIRQ}$  interrupts. Thereafter, software cannot set the X bit. Thus, an  $\overline{XIRQ}$  interrupt is a nonmaskable interrupt. Because the operation of the I-bit-related interrupt structure has no effect on the X bit, the internal  $\overline{XIRQ}$  pin remains non-masked. In the interrupt priority logic, the  $\overline{XIRQ}$  interrupt has a higher priority than any source that is maskable by the I bit. All I-bit-related interrupts operate normally with their own priority relationship.

When an I-bit-related interrupt occurs, the I bit is automatically set by hardware after stacking the CCR byte. The X bit is not affected. When an X-bit-related interrupt occurs, both the X and I bits are automatically set by hardware after stacking the CCR. A return from interrupt instruction restores the X and I bits to their pre-interrupt request state.

**5.4.3 Illegal Opcode Trap**

Because not all possible opcodes or opcode sequences are defined, the MCU includes an illegal opcode detection circuit, which generates an interrupt request. When an illegal opcode is detected and the interrupt is recognized, the current value of the program counter is stacked. After interrupt service is complete, reinitialize the stack pointer so repeated execution of illegal opcodes does not cause stack underflow. Left uninitialized, the illegal opcode vector can point to a memory location that contains an illegal opcode. This condition causes an infinite loop that causes stack underflow. The stack grows until the system crashes.

The illegal opcode trap mechanism works for all unimplemented opcodes on all four opcode map pages. The address stacked as the return address for the illegal opcode interrupt is the address of the first byte of the illegal opcode. Otherwise, it would be almost impossible to determine whether the illegal opcode had been one or two bytes.

The stacked return address can be used as a pointer to the illegal opcode so the illegal opcode service routine can evaluate the offending opcode.

#### 5.4.4 Software Interrupt

SWI is an instruction, and thus cannot be interrupted until complete. SWI is not inhibited by the global mask bits in the CCR. Because execution of SWI sets the I mask bit, once an SWI interrupt begins, other interrupts are inhibited until SWI is complete, or until user software clears the I bit in the CCR.

#### 5.4.5 Maskable Interrupts

The maskable interrupt structure of the MCU can be extended to include additional external interrupt sources through the  $\overline{\text{IRQ}}$  pin. The default configuration of this pin is a low-level sensitive wired-OR network. When an event triggers an interrupt, a software accessible interrupt flag is set. When enabled, this flag causes a constant request for interrupt service. After the flag is cleared, the service request is released.

#### 5.4.6 Reset and Interrupt Processing

**Figure 5-1** and **Figure 5-1** illustrate the reset and interrupt process. **Figure 5-1** illustrates how the CPU begins from a reset and how interrupt detection relates to normal opcode fetches. **Figure 5-1** is an expansion of a block in **Figure 5-1** and illustrates interrupt priorities. **Figure 5-2** shows the resolution of interrupt sources within the SCI subsystem.

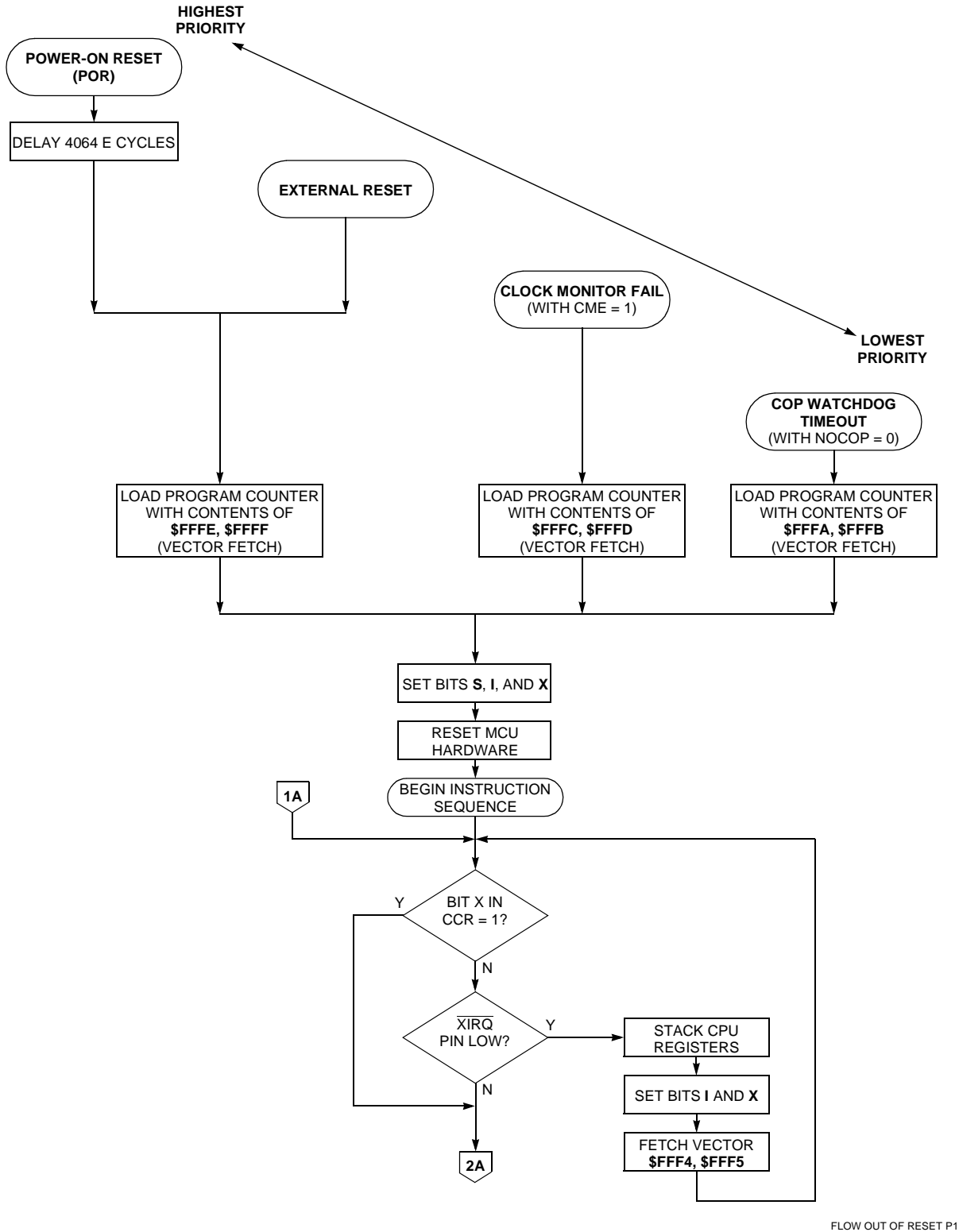

Figure 5-1 Processing Flow out of Reset (1 of 2)

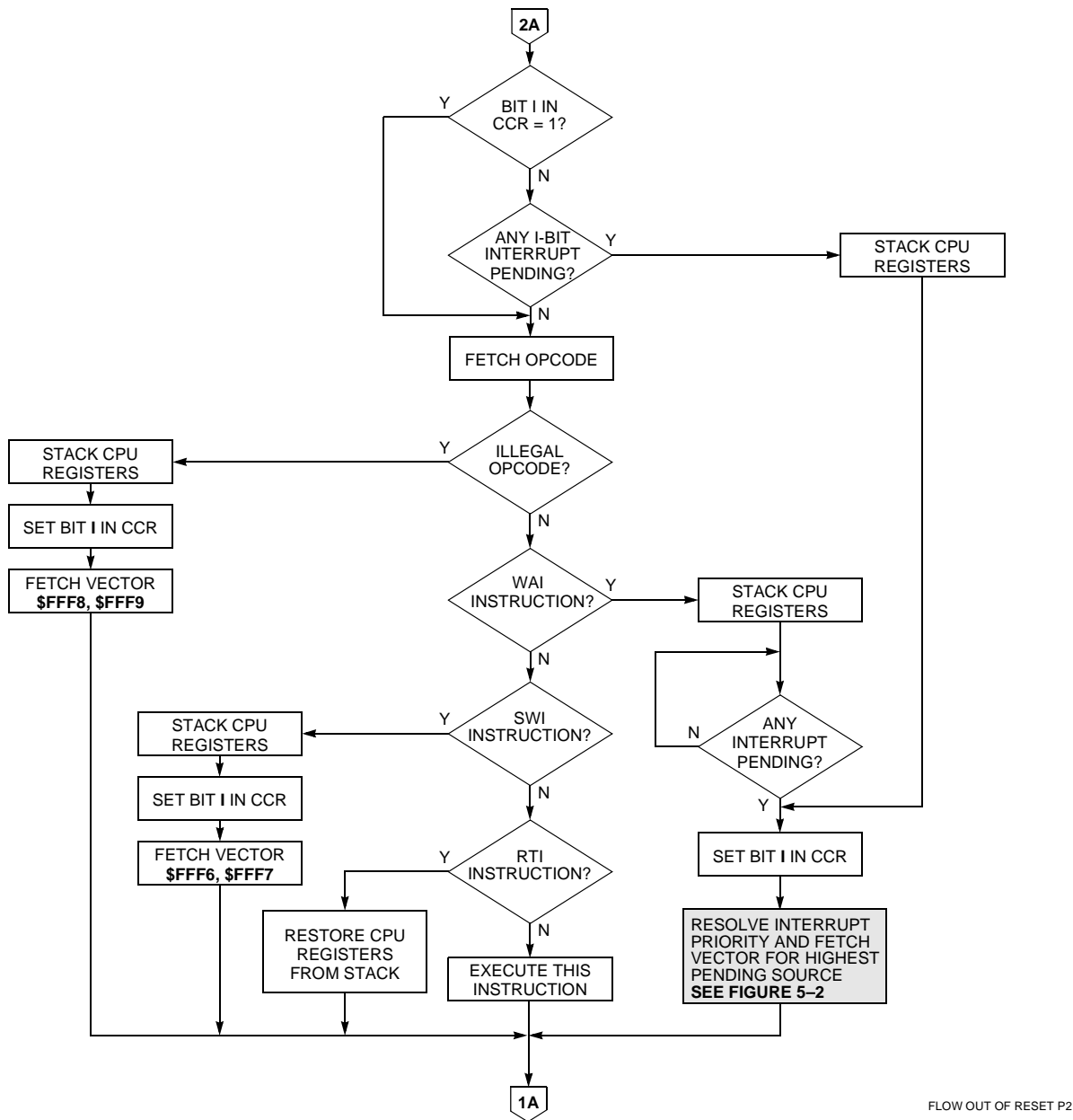
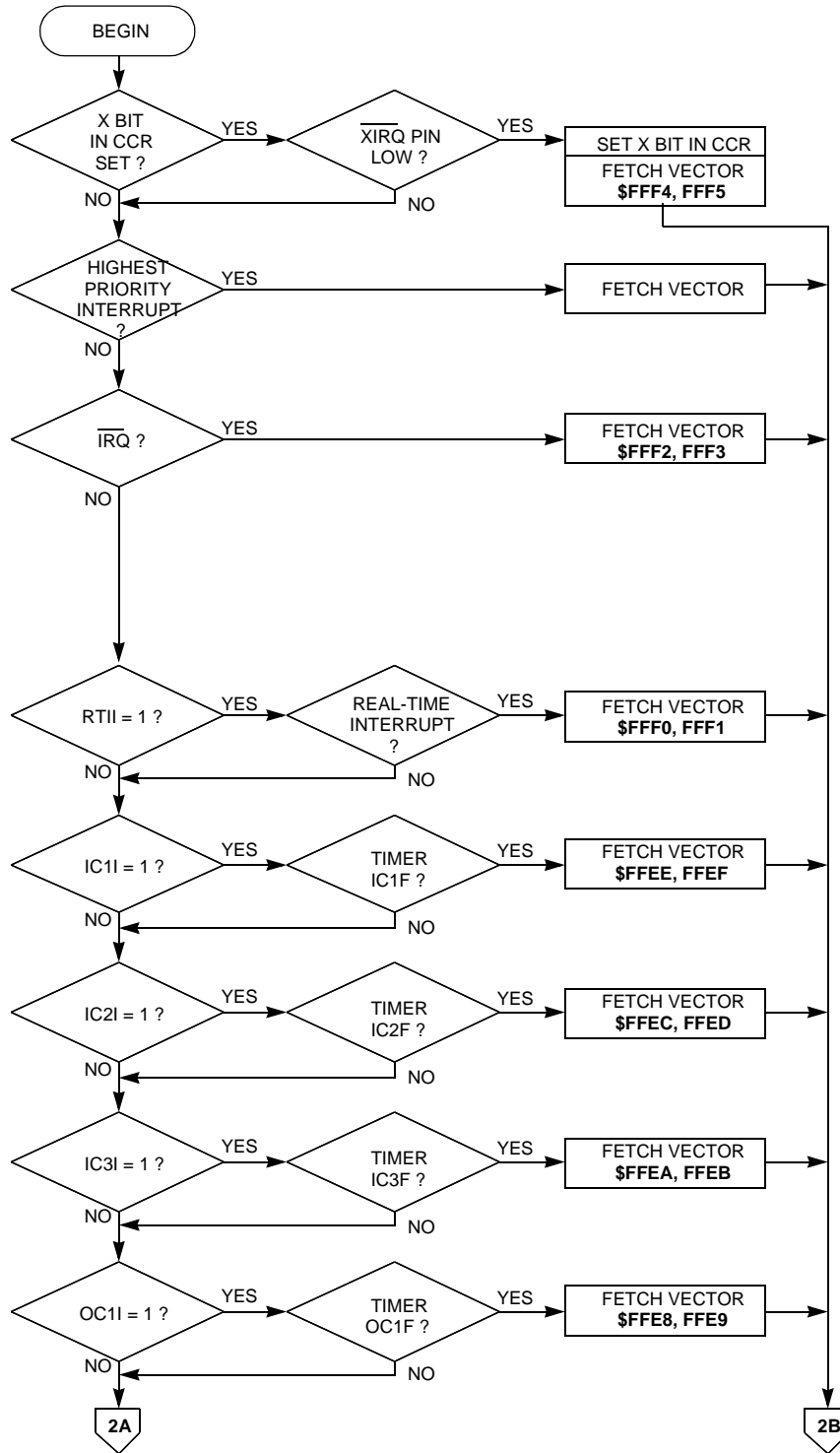

Figure 5-1 Processing Flow out of Reset (2 of 2)



INT PRIORITY RES P1

Figure 5-2 Interrupt Priority Resolution (1 of 2)

Freescale Semiconductor, Inc.

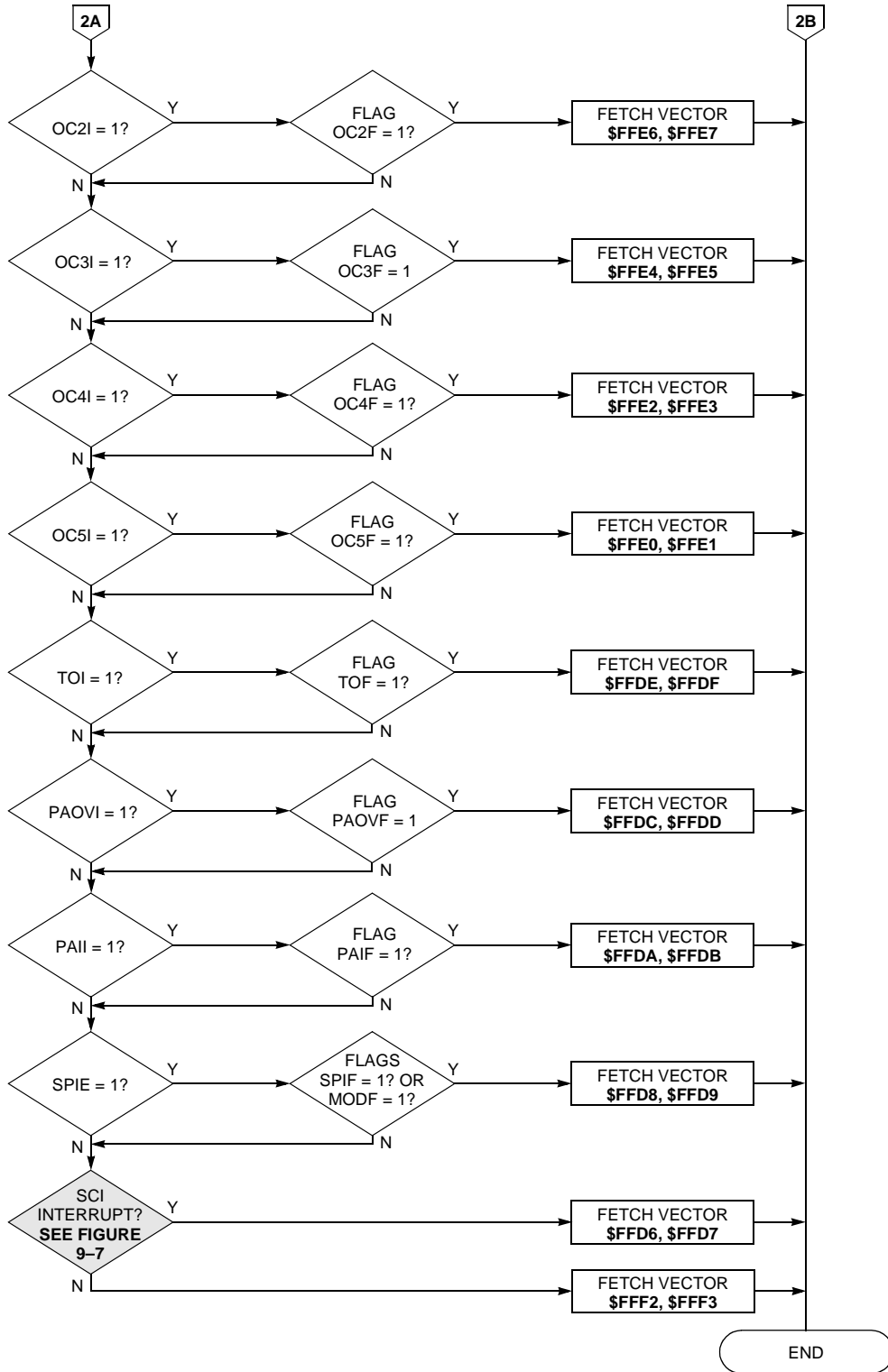

INT PRI RES P2

Figure 5-2 Interrupt Priority Resolution (2 of 2)

RESETS AND INTERRUPTS

Freescale Semiconductor, Inc.

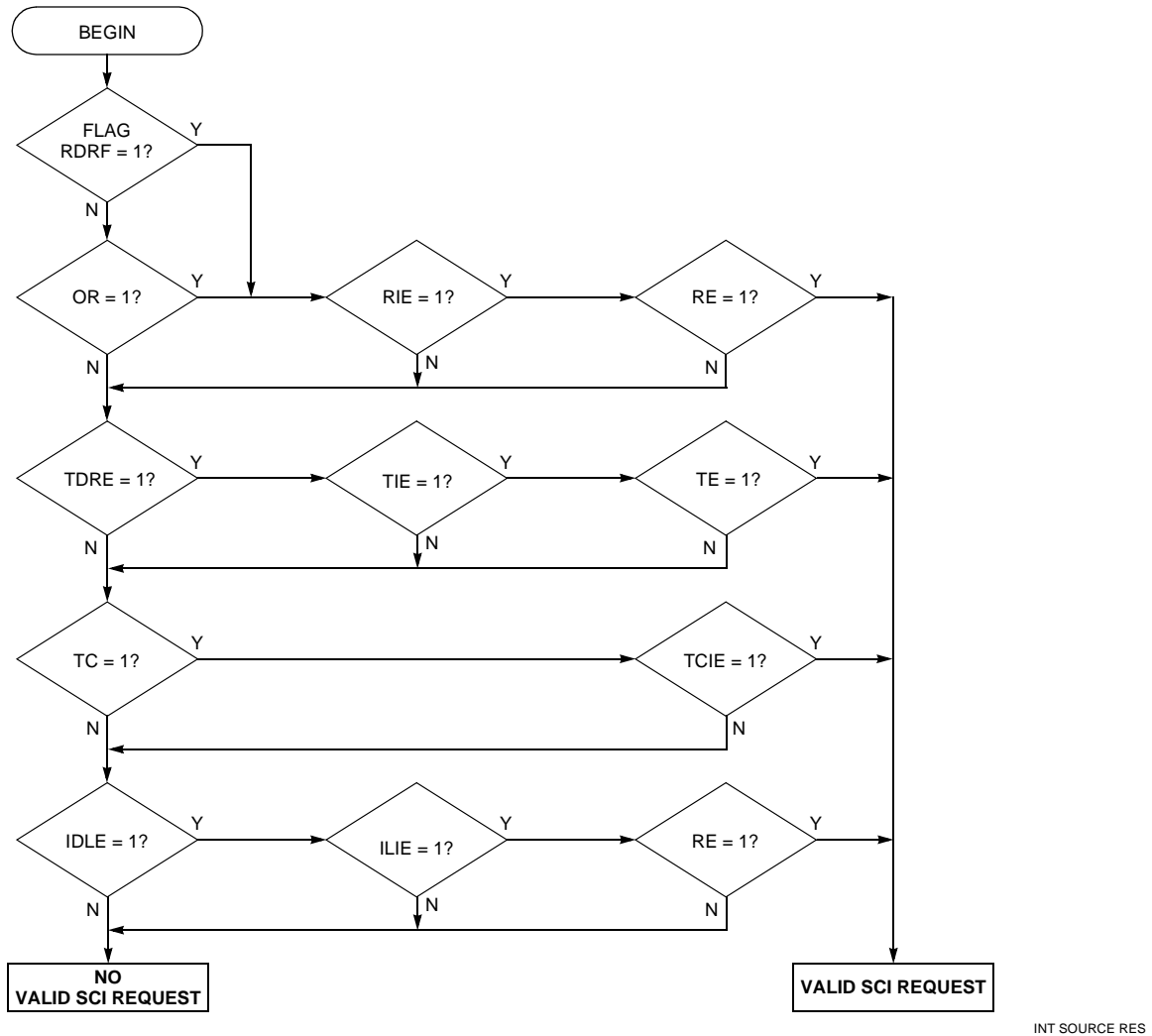

Figure 5-3 Interrupt Source Resolution within SCI

### 5.5 Low-Power Operation

Both STOP and WAIT suspend CPU operation until a reset or interrupt occurs. The WAIT condition suspends processing and reduces power consumption to an intermediate level. The STOP condition turns off all on-chip clocks and reduces power consumption to an absolute minimum while retaining the contents of all 192 bytes of RAM.

#### 5.5.1 WAIT

The WAI opcode places the MCU in the WAIT condition, during which the CPU registers are stacked and CPU processing is suspended until a qualified interrupt is detected. The interrupt can be an external IRQ, an XIRQ, or any of the internally generated interrupts, such as the timer or serial interrupts. The on-chip crystal oscillator remains active throughout the WAIT standby period.

The reduction of power in the WAIT condition depends on how many internal clock sig-

nals driving on-chip peripheral functions can be shut down. The CPU is always shut down during WAIT. While in the wait state, the address/data bus repeatedly runs read cycles to the address where the CCR contents were stacked. The MPU leaves the wait state when it senses any interrupt that has not been masked.

The free-running timer system is shut down only if the I bit is set to one and the COP system is disabled by NOCOP being set to one. Several other systems can also be in a reduced power consumption state depending on the state of software-controlled configuration control bits. The SPI system is enabled or disabled by the SPE control bit. The SCI transmitter is enabled or disabled by the TE bit, and the SCI receiver is enabled or disabled by the RE bit. Therefore the power consumption in WAIT is dependent on the particular application.

### 5.5.2 STOP

Executing the STOP instruction while the S bit in the CCR is equal to zero places the MCU in the STOP condition. If the S bit is not zero, the STOP opcode is treated as a no-op (NOP). The STOP condition offers minimum power consumption because all clocks, including the crystal oscillator, are stopped while in this mode. To exit STOP and resume normal processing, a logic low level must be applied to one of the external interrupts ( $\overline{\text{IRQ}}$  or  $\overline{\text{XIRQ}}$ ), or to the  $\overline{\text{RESET}}$  pin. A pending edge-triggered  $\overline{\text{IRQ}}$  can also bring the CPU out of STOP.

Because all clocks are stopped in this mode, all internal peripheral functions also stop. The data in the internal RAM is retained as long as  $V_{DD}$  power is maintained. The CPU state and I/O pin levels are static and are unchanged by STOP. Therefore, when an interrupt comes to restart the system, the MCU resumes processing as if there were no interruption. If reset is used to restart the system a normal reset sequence results where all I/O pins and functions are also restored to their initial states.

To use the  $\overline{\text{IRQ}}$  pin as a means of recovering from STOP, the I bit in the CCR must be clear ( $\overline{\text{IRQ}}$  not masked). The  $\overline{\text{XIRQ}}$  pin can be used to wake up the MCU from STOP regardless of the state of the X bit in the CCR, although the recovery sequence depends on the state of the X bit. If X is set to zero ( $\overline{\text{XIRQ}}$  not masked), the MCU starts up, beginning with the stacking sequence leading to normal service of the  $\overline{\text{XIRQ}}$  request. If X is set to one ( $\overline{\text{XIRQ}}$  masked or inhibited), then processing continues with the instruction that immediately follows the STOP instruction, and no  $\overline{\text{XIRQ}}$  interrupt service is requested or pending.

Because the oscillator is stopped in STOP mode, a restart delay may be imposed to allow oscillator stabilization upon leaving STOP. If the internal oscillator is being used, this delay is required; however, if a stable external oscillator is being used, the DLY control bit can be used to bypass this startup delay. The DLY control bit is set by reset and can be optionally cleared during initialization. If the DLY equal to zero option is used to avoid startup delay on recovery from STOP, then reset should not be used as the means of recovering from STOP, as this causes DLY to be set again by reset, imposing the restart delay. This same delay also applies to power-on-reset, regardless of the state of the DLY control bit, but does not apply to a reset while the clocks are running.



**SECTION 6  
PARALLEL I/O**

The MC68HC11D3 has four 8-bit I/O ports; A, B, C, and D. In single-chip and bootstrap modes, all ports are parallel I/O data ports. In expanded multiplexed and test modes, ports B and C, and lines DATA6/AS and DATA7/R/W are a memory expansion bus with port B as the high order address bus, port C as the multiplexed address and data bus, AS as the demultiplexing signal, and R/W as the data bus direction control. Refer to **Table 6-1**, which is a summary of the ports and their shared functions:

**Table 6-1 I/O Ports**

Port	Input Pins	Output Pins	Bidirectional Pins	Shared Functions
Port A	3	3	2	Timer
Port B	—	—	8	High Order Address
Port C	—	—	8	Low Order Address and Data Bus
Port D	—	—	8	SCI, SPI, AS, and R/

**6.1 Port A**

Port A bits handle the timer functions and can also be used as general-purpose I/O. In both the normal operating modes, port A can be configured for four timer input capture (IC) and three timer output compare (OC) functions, or four OC and three IC functions with either a pulse accumulator input (PAI) or a fifth OC function.

**PORTA — Port A Data**

**\$0000**

	Bit 7	6	5	4	3	2	1	Bit 0
	PA7	PA6*	PA5	PA4*	PA3	PA2	PA1	PA0
RESET:	HiZ	0	0	0	HiZ	HiZ	HiZ	HiZ
Alt. Func:	PAI	OC2	OC3	OC4	IC4/OC5	IC1	IC2	IC3
And/or:	OC1	OC1	OC1	OC1	OC1	—	—	—

\*This pin is not bonded in the 40-pin version.

**6.2 Port B**

In single-chip mode, all port B pins are general-purpose I/O (PB[7:0]). In expanded multiplexed mode, all port B pins act as high-order address bits (ADDR[15:8]).

**PORTB — Port B Data**

**\$0004**

	Bit 7	6	5	4	3	2	1	Bit 0
	PB7	PB6	PB5	PB4	PB3	PB2	PB1	PB0
S. Chip or Boot:	PB7	PB6	PB5	PB4	PB3	PB2	PB1	PB0
RESET:	Reset configures pins as HiZ inputs							
Expan. or Test:	ADDR15	ADDR14	ADDR13	ADDR12	ADDR11	ADDR10	ADDR9	ADDR8
RESET:	Reset configures pins as high-order address outputs							

**PARALLEL I/O**

**DDRB** — Data Direction Register for Port B

**\$0006**

	Bit 7	6	5	4	3	2	1	Bit 0
	DDB7	DDB6	DDB5	DDB4	DDB3	DDB2	DDB1	DDB0
RESET:	0	0	0	0	0	0	0	0

**DDB[7:0]** — Data Direction for Port B

- 0 = Corresponding port B pin configured for input only
- 1 = Corresponding port B pin configured as output

**6.3 Port C**

Port C pins are general-purpose I/O (PC[7:0]) in single-chip mode. In expanded multiplexed mode, port C pins are configured as multiplexed address/data pins. During the data cycle, bits [7:0] (PC[7:0]) are bidirectional data pins controlled by the R/W signal.

**PORTC** — Port C Data

**\$0003**

	Bit 7	6	5	4	3	2	1	Bit 0
	PC7	PC6	PC5	PC4	PC3	PC2	PC1	PC0
S. Chip or Boot:	PC7	PC6	PC5	PC4	PC3	PC2	PC1	PC0
RESET:	Reset configures pins as HiZ inputs							
Expan. or Test:	ADDR7/ DATA7	ADDR6/ DATA6	ADDR5/ DATA5	ADDR4/ DATA4	ADDR3/ DATA3	ADDR2/ DATA2	ADDR1/ DATA1	ADDR0/ DATA0
RESET:	Reset configures pins as multiplexed, low-order address/data I/O							

**DDRC** — Data Direction Register for Port C

**\$0007**

	Bit 7	6	5	4	3	2	1	Bit 0
	DDC7	DDC6	DDC5	DDC4	DDC3	DDC2	DDC1	DDC0
RESET:	0	0	0	0	0	0	0	0

**DDC[7:0]** — Data Direction for Port C

- 0 = Input
- 1 = Output

**6.4 Port D**

The eight port D bits (PD[7:0]) can be used for general-purpose I/O, for the SCI and SPI subsystems, or for bus data direction control. Port D can be read at any time. Inputs return the sensed levels at the pin; outputs return the input level of the port D pin drivers. If port D is written, the data is stored in an internal latch, and can be driven only if port D is configured for general-purpose output. This port shares functions with the on-chip SCI and SPI subsystems, while bits 6 and 7 control the direction of data flow on the bus in expanded and special test modes.

**PORTD — Port D Data**

**\$0008**

	Bit 7	6	5	4	3	2	1	Bit 0
	PD7	PD6	PD5	PD4	PD3	PD2	PD1	PD0
RESET:	0	0	0	0	0	0	0	0
Alt. Func.:	R/W	AS		SCK	MOSI	MISO	TxD	RxD

**DDRD — Data Direction Register for Port D**

**\$0009**

	Bit 7	6	5	4	3	2	1	Bit 0
	DDD7	DDD6	DDD5	DDD4	DDD3	DDD2	DDD1	DDD0
RESET:	0	0	0	0	0	0	0	0

**DDD[7:0] — Data Direction for Port D**

When port D is a general-purpose I/O port, the DDRD register controls the direction of the I/O pins as follows:

- 0 = Configures the corresponding port D pin for input
- 1 = Configures the corresponding port D pin for output

In expanded and test modes, bits 6 and 7 are dedicated AS and R/W outputs.

When port D is functioning with the SPI system enabled, bit 5 is dedicated as the slave select ( $\overline{SS}$ ) input. In SPI slave mode, DDD5 has no meaning or effect. In SPI master mode, DDD5 affects port D bit 5 as follows:

- 0 = Port D bit 5 is an error-detect input to the SPI.
- 1 = Port D bit 5 is configured as a general-purpose output line.

If the SPI is enabled and expects port D bits 2, 3, and 4 (MISO, MOSI, and SCK) to be inputs, then they are inputs, regardless of the state of DDRD bits 2, 3, and 4. If the SPI expects port D bits 2, 3, and 4 to be outputs, they are outputs only if DDRD bits 2, 3, and 4 are set.

**PACTL — Pulse Accumulator Control**

**\$0026**

	Bit 7	6	5	4	3	2	1	Bit 0
	DDRA7	PAEN	PAMOD	PEDGE	DDRA3	I4/O5	RTR1	RTR0
RESET:	0	0	0	0	0	0	0	0

**DDRA7 — Data Direction Control for Port A Bit 7**

Refer to **SECTION 9 TIMING SYSTEM**.

**PAEN — Pulse Accumulator System Enable**

Refer to **SECTION 9 TIMING SYSTEM**.

**PAMOD — Pulse Accumulator Mode**

Refer to **SECTION 9 TIMING SYSTEM**.

**PEDGE — Pulse Accumulator Edge Control**

Refer to **SECTION 9 TIMING SYSTEM**.

**DDRA3 — Data Direction for Port A Bit 3**

Overridden if an output compare function is configured to control the PA3 pin.

- 0 = Input only
- 1 = Output

**PARALLEL I/O**

I4/O5 — Configure TI4/O5 register for IC4 or OC5

0 = OC5 function enabled

1 = IC4 function enabled

RTR[1:0] — Real-Time Interrupt (RTI) Rate

Refer to **SECTION 9 TIMING SYSTEM**.

**6.5 Parallel I/O Control Register (PIOC)**

PIOC configures and controls handshake I/O functions in MCUs where this function is available. In the MC68HC11D3, however, only the CWOM bit in the PIOC register is usable. The CWOM bit is cleared so that port C is not in wired-OR mode.

**PIOC**— Parallel I/O Control

**\$0002**

	Bit 7	6	5	4	3	2	1	Bit 0
	0	0	CWOM	0	0	0	0	0
RESET:	0	0	0	0	0	0	0	0

CWOM — Port C Wired-OR Mode (affects all eight port C pins)

0 = Port C outputs are normal CMOS outputs

1 = Port C outputs are open-drain outputs

## SECTION 7

### SERIAL COMMUNICATIONS INTERFACE

The serial communications interface (SCI) is a universal asynchronous receiver transmitter (UART), one of two independent serial I/O subsystems in the MC68HC11D3. It has a standard nonreturn to zero (NRZ) format (one start, eight or nine data, and one stop bit). Several baud rates are available. The SCI transmitter and receiver are independent, but use the same data format and bit rate.

#### 7.1 Data Format

The serial data format requires the following conditions:

1. An idle line in the high state before transmission or reception of a message
2. A start bit, logic zero, transmitted or received, that indicates the start of each character
3. Data that is transmitted and received least significant bit (LSB) first
4. A stop bit, logic one, used to indicate the end of a frame (A frame consists of a start bit, a character of eight or nine data bits, and a stop bit.)
5. A break (defined as the transmission or reception of a logic zero for some multiple number of frames).

Selection of the word length is controlled by the M bit of SCI control register SCCR1.

#### 7.2 Transmit Operation

The SCI transmitter includes a parallel transmit data register (SCDR) and a serial shift register. The contents of the serial shift register can only be written through the SCDR. This double buffered operation allows a character to be shifted out serially while another character is waiting in the SCDR to be transferred into the serial shift register. The output of the serial shift register is applied to TxD as long as transmission is in progress or the transmit enable (TE) bit of serial communication control register 2 (SCCR2) is set. The block diagram, **Figure 7-1**, shows the transmit serial shift register, and the buffer logic at the top of the figure.

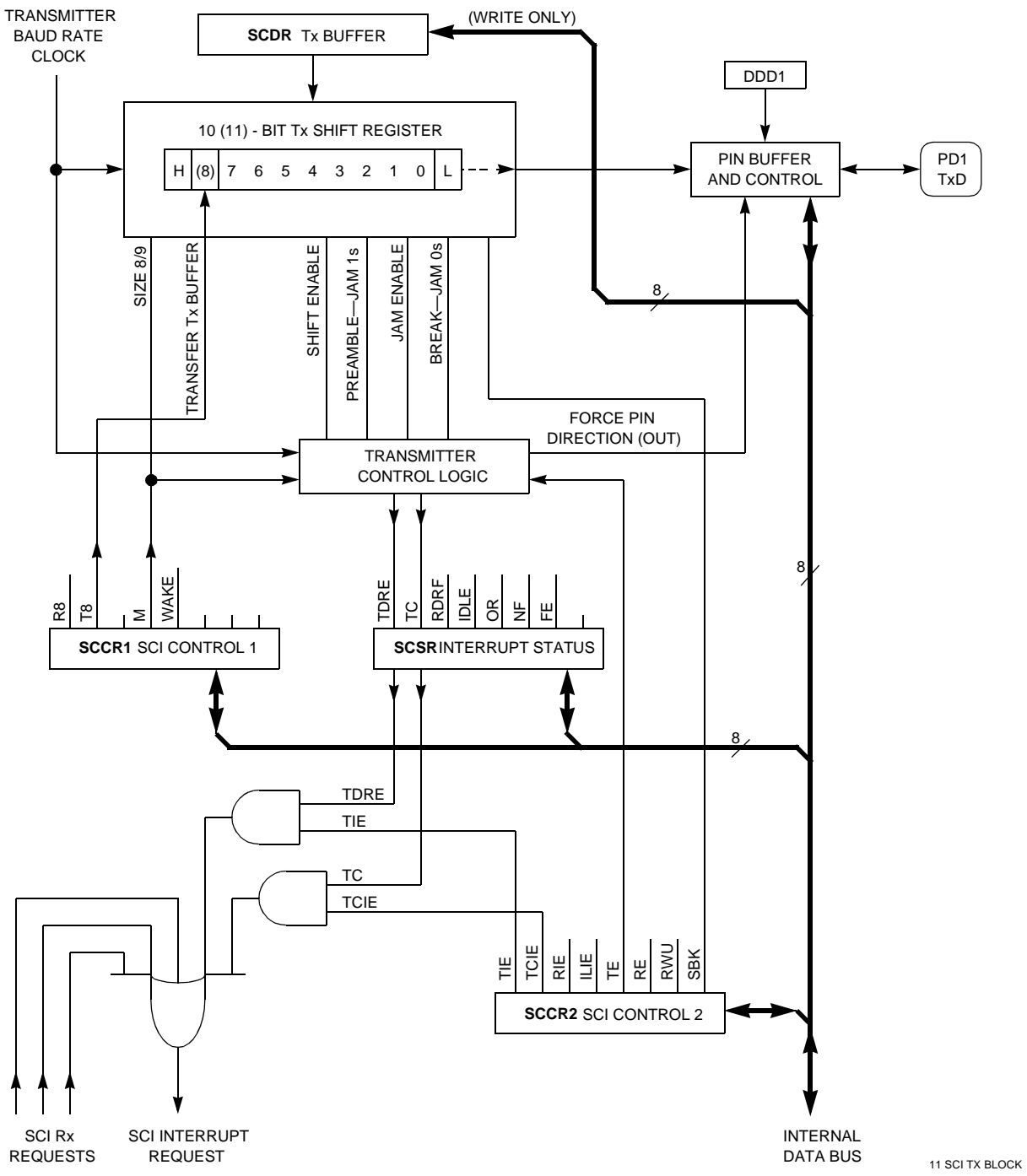

11 SCI TX BLOCK

Figure 7-1 SCI Transmitter Block Diagram

7.3 Receive Operation

During receive operations, the transmit sequence is reversed. The serial shift register receives data and transfers it to a parallel receive data register (SCDR) as a complete word. Refer to **Figure 7-2**. This double buffered operation allows a character to be shifted in serially while another character is already in the SCDR. An advanced data

recovery scheme distinguishes valid data from noise in the serial data stream. The data input is selectively sampled to detect receive data, and a majority voting circuit determines the value and integrity of each bit.

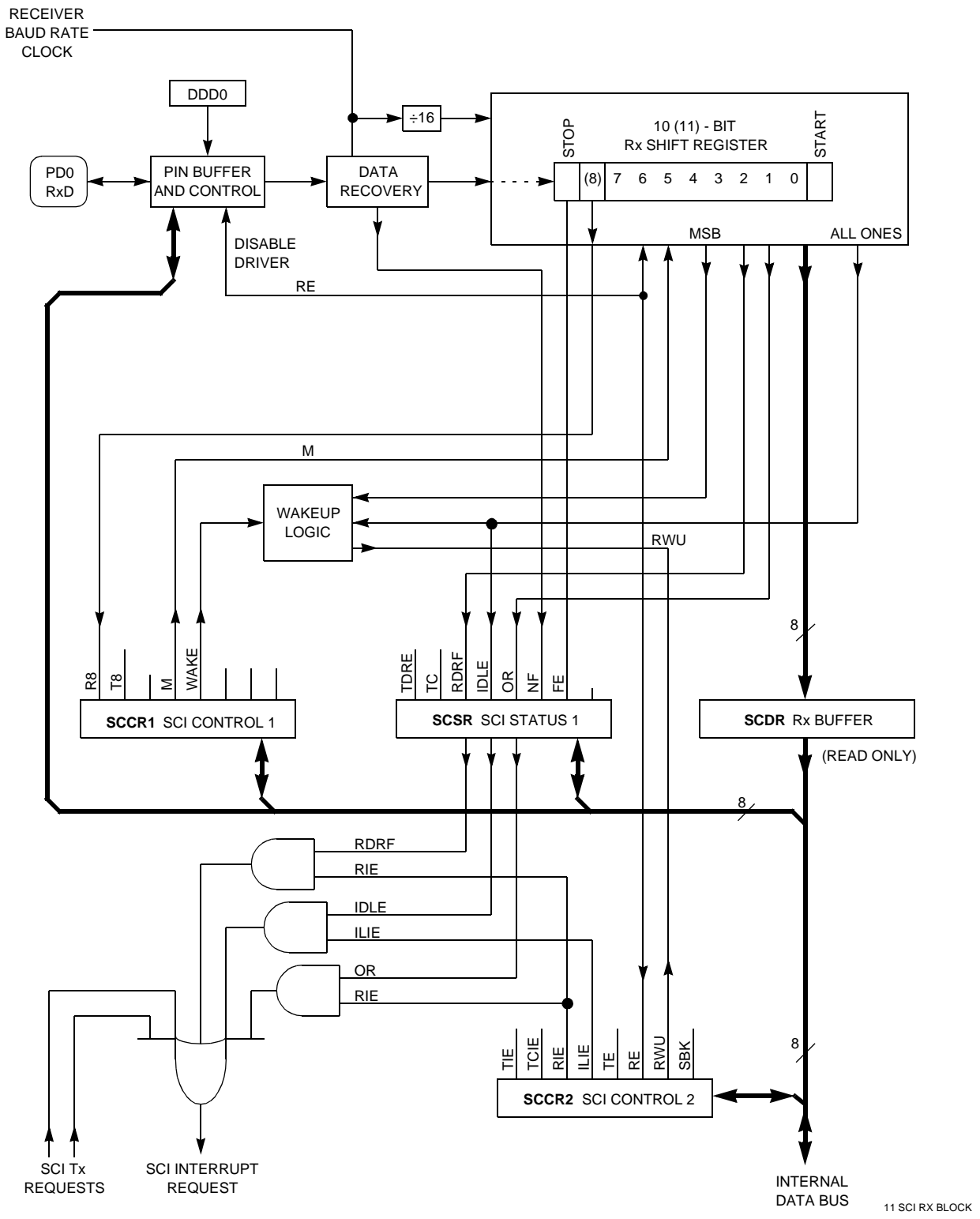

**Figure 7-2 SCI Receiver Block Diagram**

**SERIAL COMMUNICATIONS INTERFACE**

## 7.4 Wake-up Feature

The wake-up feature reduces SCI service overhead in multiple receiver systems. Software for each receiver evaluates the first character of each message. The receiver is placed in wakeup mode by writing a one to the RWU bit in the SCCR2 register. While RWU is one, all of the receiver-related status flags (RDRF, IDLE, OR, NF, and FE) are inhibited (cannot become set). Although RWU can be cleared by a software write to SCCR2, to do so would be unusual. Normally RWU is set by software and is cleared automatically with hardware. Whenever a new message begins, logic alerts the sleeping receivers to wake up and evaluate the initial character of the new message.

Two methods of wake-up are available: idle line wake-up and address mark wake-up. During idle line wake-up, a sleeping receiver awakens as soon as the RxD line becomes idle. In the address mark wake-up, logic one in the most significant bit (MSB) of a character wakes up all sleeping receivers.

### 7.4.1 Idle-Line Wakeup

To use the receiver wake-up method, establish a software addressing scheme to allow the transmitting devices to direct a message to individual receivers or to groups of receivers. This addressing scheme can take any form as long as all transmitting and receiving devices are programmed to understand the same scheme. Because the addressing information is usually the first frame(s) in a message, receivers that are not part of the current task do not become burdened with the entire set of addressing frames. All receivers are awake (RWU = 0) when each message begins. As soon as a receiver determines that the message is not intended for it, software sets the RWU bit (RWU = 1), which inhibits further flag setting until the RxD line goes idle at the end of the message. As soon as an idle line is detected by receiver logic, hardware automatically clears the RWU bit so that the first frame of the next message can be received. This type of receiver wakeup requires a minimum of one idle-line frame time between messages, and no idle time between frames in a message.

### 7.4.2 Address-Mark Wakeup

The serial characters in this type of wakeup consist of seven (eight if  $M = 1$ ) information bits and an MSB, which indicates an address character (when set to one — mark). The first character of each message is an addressing character (MSB = 1). All receivers in the system evaluate this character to determine if the remainder of the message is directed toward this particular receiver. As soon as a receiver determines that a message is not intended for it, the receiver activates the RWU function by using a software write to set the RWU bit. Because setting RWU inhibits receiver-related flags, there is no further software overhead for the rest of this message. When the next message begins, its first character has its MSB set, which automatically clears the RWU bit and enables normal character reception. The first character whose MSB is set is also the first character to be received after wakeup because RWU gets cleared before the stop bit for that frame is serially received. This type of wakeup allows messages to include gaps of idle time, unlike the idle-line method, but there is a loss of efficiency because of the extra bit time for each character (address bit) required for all characters.

### 7.5 SCI Error Detection

Three error conditions, SCDR overrun, received bit noise, and framing can occur during generation of SCI system interrupts. Three bits (OR, NF, and FE) in the serial communications status register (SCSR) indicate if one of these error conditions exists. The overrun error (OR) bit is set when the next byte is ready to be transferred from the receive shift register to the SCDR and the SCDR is already full (RDRF bit is set). When an overrun error occurs, the data that caused the overrun is lost and the data that was already in SCDR is not disturbed. The OR is cleared when the SCSR is read (with OR set), followed by a read of the SCDR.

The noise flag (NF) bit is set if there is noise on any of the received bits, including the start and stop bits. The NF bit is not set until the RDRF flag is set. The NF bit is cleared when the SCSR is read (with FE equal to one) followed by a read of the SCDR.

When no stop bit is detected in the received data character, the framing error (FE) bit is set. FE is set at the same time as the RDRF. If the byte received causes both framing and overrun errors, the processor only recognizes the overrun error. The framing error flag inhibits further transfer of data into the SCDR until it is cleared. The FE bit is cleared when the SCSR is read (with FE equal to one) followed by a read of the SCDR.

### 7.6 SCI Registers

There are five addressable registers in the SCI.

#### 7.6.1 Serial Communications Data Register (SCDR)

SCDR is a parallel register that performs two functions. It is the receive data register when it is read, and the transmit data register when it is written. Reads access the receive data buffer and writes access the transmit data buffer. Receive and transmit are double buffered.

#### SCDR — SCI Data Register \$002F

	Bit 7	6	5	4	3	2	1	Bit 0
	R7/T7	R6/T6	R5/T5	R4/T4	R3/T3	R2/T2	R1/T1	R0/T0
RESET:	U*	U	U	U	U	U	U	U

\*U = Unaffected

#### 7.6.2 Serial Communications Control Register 1 (SCCR1)

The SCCR1 register provides the control bits that determine word length and select the method used for the wake-up feature.

#### SCCR1 — SCI Control Register 1 \$002C

	Bit 7	6	5	4	3	2	1	Bit 0
	R8	T8	0	M	WAKE	0	0	0
RESET:	U	U	0	0	0	0	0	0

#### R8 — Receive Data Bit 8

If M bit is set, R8 stores the ninth bit in the receive data character.

T8 — Transmit Data bit 8

If M bit is set, T8 stores ninth bit in transmit data character.

M — Mode (Select Character Format)

0 = Start bit, 8 data bits, 1 stop bit

1 = Start bit, 9 data bits, 1 stop bit

WAKE — Wake-up by Address Mark/Idle

0 = Wake-up by IDLE line recognition

1 = Wake-up by address mark (most significant data bit set)

### 7.6.3 Serial Communications Control Register 2 (SCCR2)

The SCCR2 register provides the control bits that enable or disable individual SCI functions.

**SCCR2** — SCI Control Register 2

**\$002D**

	Bit 7	6	5	4	3	2	1	Bit 0
	TIE	TCIE	RIE	ILIE	TE	RE	RWU	SBK
RESET:	0	0	0	0	0	0	0	0

TIE — Transmit Interrupt Enable

0 = TDRE interrupts disabled

1 = SCI interrupt requested when TDRE status flag is set

TCIE — Transmit Complete Interrupt Enable

0 = TC interrupts disabled

1 = SCI interrupt requested when TC status flag is set

RIE — Receiver Interrupt Enable

0 = RDRF and OR interrupts disabled

1 = SCI interrupt requested when RDRF flag or the OR status flag is set

ILIE — Idle Line Interrupt Enable

0 = IDLE interrupts disabled

1 = SCI interrupt requested when IDLE status flag is set

TE — Transmitter Enable

When TE goes from zero to one, one unit of idle character time (logic one) is queued as a preamble.

0 = Transmitter disabled

1 = Transmitter enabled

RE — Receiver Enable

0 = Receiver disabled

1 = Receiver enabled

RWU — Receiver Wake-Up Control

0 = Normal SCI receiver

1 = Wake-up enabled and receiver interrupts inhibited

**SBK — Send Break**

At least one character time of break is queued and sent each time SBK is written to one. More than one break may be sent if the transmitter is idle at the time the SBK bit is toggled on and off, as the baud rate clock edge could occur between writing the one and writing the zero to SBK.

- 0 = Break generator off
- 1 = Break codes generated as long as SBK = 1

**7.6.4 Serial Communication Status Register (SCSR)**

The SCSR provides inputs to the interrupt logic circuits for generation of the SCI system interrupt.

**SCSR — SCI Status Register \$002E**

	Bit 7	6	5	4	3	2	1	Bit 0
	TDRE	TC	RDRF	IDLE	OR	NF	FE	0
RESET:	1	1	0	0	0	0	0	0

**TDRE — Transmit Data Register Empty Flag**

This flag is set when SCDR is empty. Clear the TDRE flag by reading SCSR with TDRE set and then writing to SCDR.

- 0 = SCDR busy
- 1 = SCDR empty

**TC — Transmit Complete Flag**

This flag is set when the transmitter is idle (no data, preamble, or break transmission in progress). Clear the TC flag by reading SCSR with TC set and then writing to SCDR.

- 0 = Transmitter busy
- 1 = Transmitter idle

**RDRF — Receive Data Register Full Flag**

This flag is set if a received character is ready to be read from SCDR. Clear the RDRF flag by reading SCSR with RDRF set and then reading SCDR.

- 0 = SCDR empty
- 1 = SCDR full

**IDLE — Idle Line Detected Flag**

This flag is set if the RxD line is idle. Once cleared, IDLE is not set again until the RxD line has been active and becomes idle again. The IDLE flag is inhibited when RWU = 1. Clear IDLE by reading SCSR with IDLE set and then reading SCDR.

- 0 = RxD line is active
- 1 = RxD line is idle

**OR — Overrun Error Flag**

OR is set if a new character is received before a previously received character is read from SCDR. Clear the OR flag by reading SCSR with OR set and then reading SCDR.

- 0 = No overrun
- 1 = Overrun detected

**NF — Noise Error Flag**

NF is set if majority sample logic detects anything other than a unanimous decision. Clear NF by reading SCSR with NF set and then reading SCDR.

- 0 = Unanimous decision
- 1 = Noise detected

**FE — Framing Error**

FE is set when a 0 is detected where a stop bit was expected. Clear the FE flag by reading SCSR with FE set and then reading SCDR.

- 0 = Stop bit detected
- 1 = 0 detected

**7.6.5 Baud Rate Register (BAUD)**

Use this register to select different baud rates for the SCI system. The SCP[1:0] bits function as a prescaler for the SCR[2:0] bits. Together, these five bits provide multiple baud rate combinations for a given crystal frequency. Normally, this register is written once during initialization. The prescaler is set to its fastest rate by default out of reset, and can be changed at any time. Refer to **Table 7-1** and **Table 7-2** for normal baud rate selections.

**BAUD — Baud Rate**

**\$002B**

	Bit 7	6	5	4	3	2	1	Bit 0
	TCLR	0	SCP1	SCP0	RCKB	SCR2	SCR1	SCR0
RESET:	0	0	0	0	0	U	U	U

TCLR — Clear Baud Rate Counters (Test)

RCKB — SCI Baud Rate Clock Check (Test)

SCP1, SCP0 — SCI Baud Rate Prescaler Selects

These two bits select a prescale factor for the SCI baud rate generator that determines the highest possible baud rate.

**Table 7-1 Baud Rate Prescale Selects**

SCP[1:0]	Divide Internal Clock By	Crystal Frequency in MHz			
		4.0 MHz (Baud)	8.0 MHz (Baud)	10.0 MHz (Baud)	12.0 MHz (Baud)
0 0	1	62.50 K	125.0 K	156.25 K	187.5 K
0 1	3	20.83 K	41.67 K	52.08 K	62.5 K
1 0	4	15.625 K	31.25 K	38.4 K	46.88 K
1 1	13	4800	9600	12.02 K	14.42 K

SCR[2:0] — SCI Baud Rate Selects

These three bits select receiver and transmitter bit rate based on output from baud rate prescaler stage.

**Table 7-2 Baud Rate Selects**

SCR[2:0]	Divide Prescaler By	Highest Baud Rate (Prescaler Output from Previous Table)		
		4800	9600	38.4 K
0 0 0	1	4800	9600	38.4 K
0 0 1	2	2400	4800	19.2 K
0 1 0	4	1200	2400	9600
0 1 1	8	600	1200	4800
1 0 0	16	300	600	2400
1 0 1	32	150	300	1200
1 1 0	64	—	150	600
1 1 1	128	—	—	300

The prescale bits, SCP[1:0], determine the highest baud rate and the SCR[2:0] bits select an additional binary submultiple ( $\geq 1$ ,  $\geq 2$ ,  $\geq 4$ , through  $\geq 128$ ) of this highest baud rate. The result of these two dividers in series is the 16 X receiver baud rate clock. The SCR[2:0] bits are not affected by reset and can be changed at any time, although they should not be changed when any SCI transfer is in progress.

**Figure 7-3** illustrates the SCI baud rate timing chain. The prescale select bits determine the highest baud rate. The rate select bits determine additional divide by two stages to arrive at the receiver timing (RT) clock rate. The baud rate clock is the result of dividing the RT clock by 16.

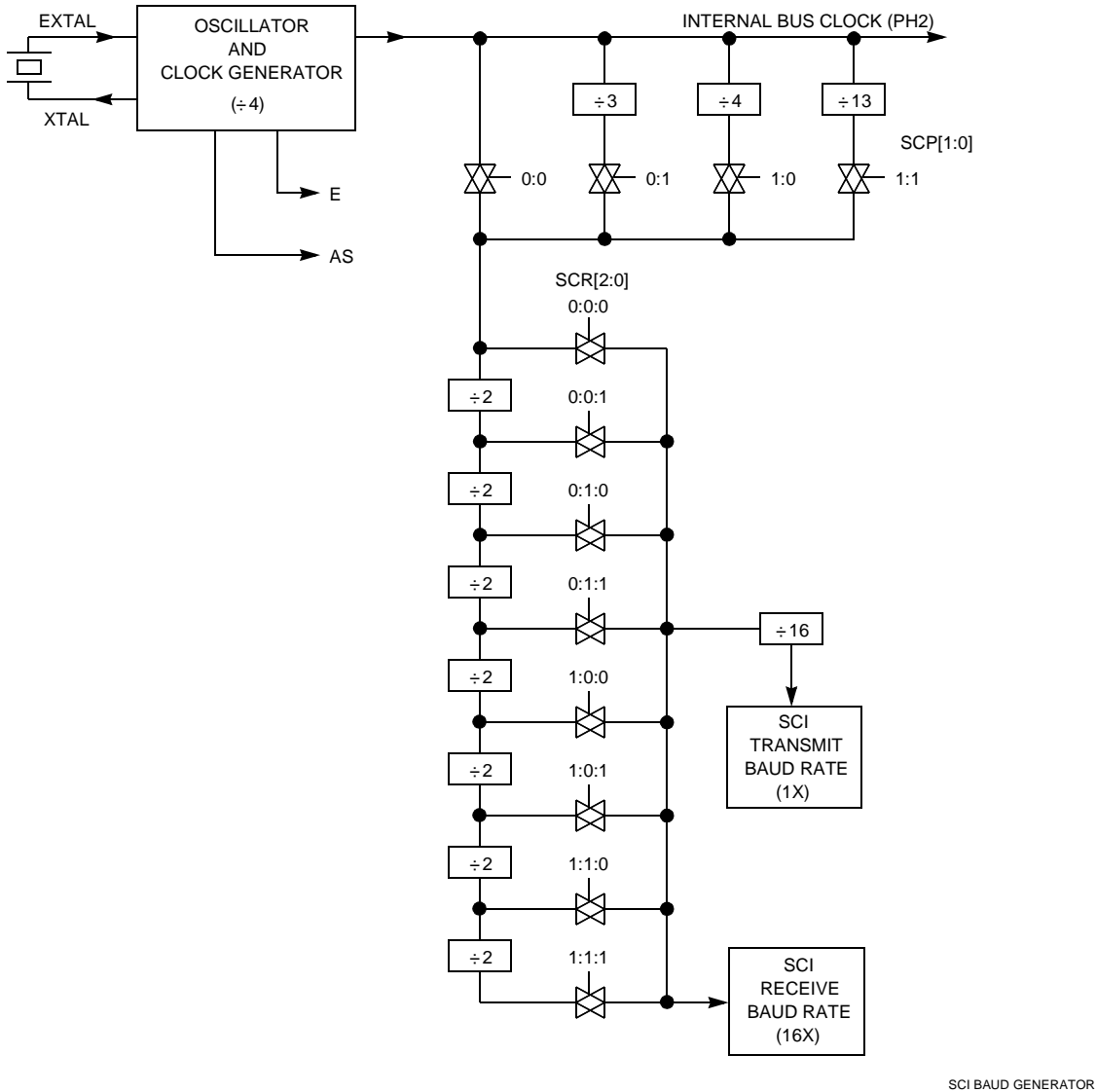

Figure 7-3 SCI Baud Rate Diagram

### 7.7 Status Flags and Interrupts

The SCI transmitter has two status flags. These status flags can be read by software (polled) to tell when the corresponding condition exists. Alternatively, a local interrupt enable bit can be set to enable each of these status conditions to generate interrupt requests when the corresponding condition is present. Status flags are automatically set by hardware logic conditions, but must be cleared by software, which provides an interlock mechanism that enables logic to know when software has noticed the status indication. The software clearing sequence for these flags is automatic — functions that are normally performed in response to the status flags also satisfy the conditions of the clearing sequence.

TDRE and TC flags are normally set when the transmitter is first enabled (TE set to one). The TDRE flag indicates there is room in the transmit queue to store another data character in the TDR. The TIE bit is the local interrupt mask for TDRE. When TIE is zero, TDRE must be polled. When TIE and TDRE are one, an interrupt is requested.

The TC flag indicates the transmitter has completed the queue. The TCIE bit is the local interrupt mask for TC. When TCIE is zero, TC must be polled; when TCIE is one and TC is one, an interrupt is requested.

Writing a zero to TE requests that the transmitter stop when it can. The transmitter completes any transmission in progress before actually shutting down. Only an MCU reset can cause the transmitter to stop and shut down immediately. If TE is written to zero when the transmitter is already idle, the pin reverts to its general-purpose I/O function (synchronized to the bit-rate clock). If anything is being transmitted when TE is written to zero, that character is completed before the pin reverts to general-purpose I/O, but any other characters waiting in the transmit queue are lost. The TC and TDRE flags are set at the completion of this last character, even though TE has been disabled.

The SCI receiver has five status flags, three of which can generate interrupt requests. The status flags are set by the SCI logic in response to specific conditions in the receiver. These flags can be read (polled) at any time by software. Refer to **Figure 7-4**, which shows SCI interrupt arbitration.

When an overrun takes place, the new character is lost, and the character that was in its way in the parallel RDR is undisturbed. RDRF is set when a character has been received and transferred into the parallel RDR. The OR flag is set instead of RDRF if overrun occurs. A new character is ready to be transferred into RDR before a previous character is read from RDR.

The NF and FE flags provide additional information about the character in the RDR, but do not generate interrupt requests.

The last receiver status flag and interrupt source come from the IDLE flag. The RxD line is idle if it has constantly been at logic one for a full character time. The IDLE flag is set only after the RxD line has been busy and becomes idle, which prevents repeated interrupts for the whole time RxD remains idle.

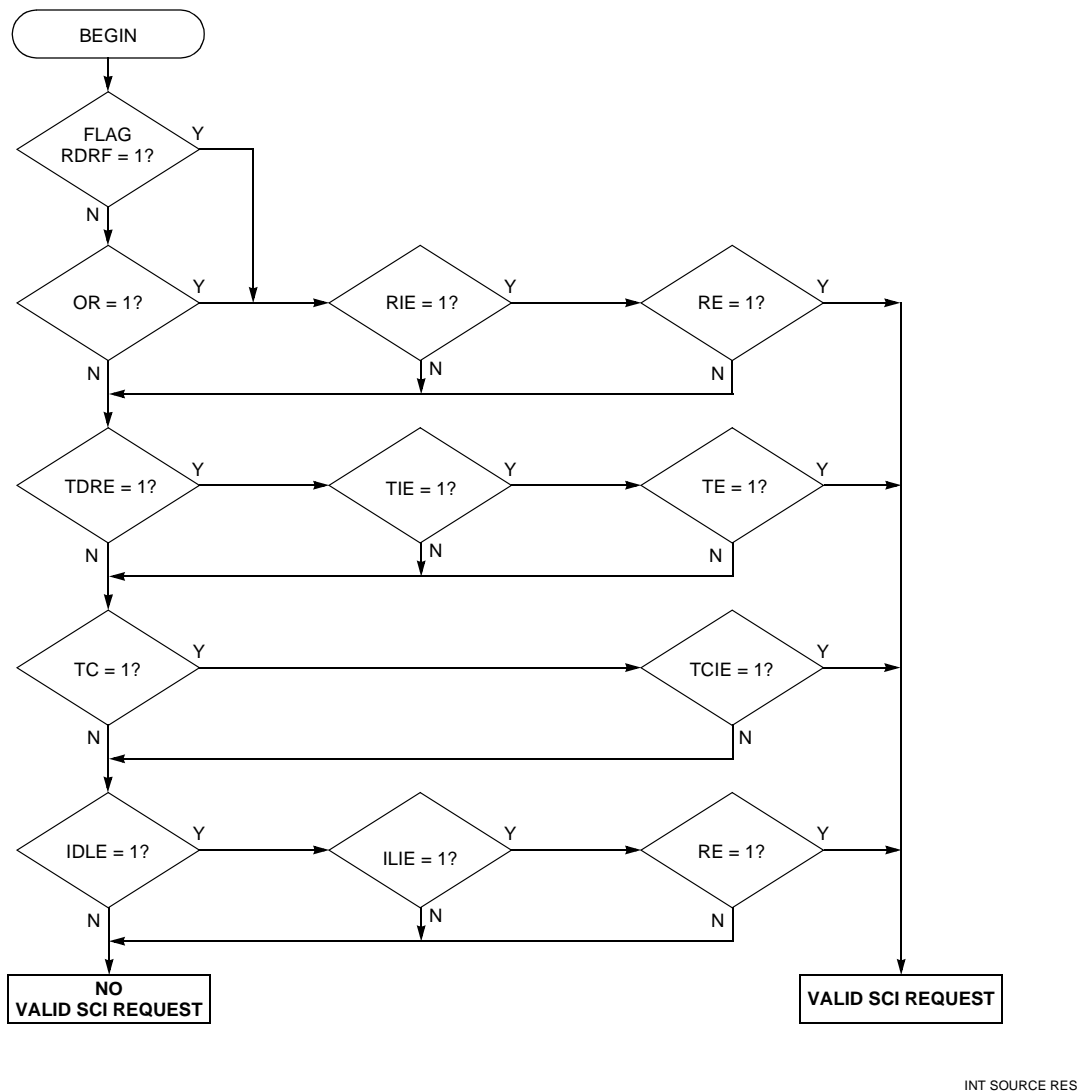

Figure 7-4 Interrupt Source Resolution within SCI

Freescale Semiconductor, Inc.

## SECTION 8

### SERIAL PERIPHERAL INTERFACE

The serial peripheral interface (SPI), an independent serial communications subsystem, allows the MCU to communicate synchronously with peripheral devices, such as transistor-transistor logic (TTL) shift registers, liquid crystal diode (LCD) display drivers, analog-to-digital converter subsystems, and other microprocessors. The SPI is also capable of inter-processor communication in a multiple master system. The SPI system can be configured as either a master or a slave device with data rates as high as one half of the E-clock rate when configured as master, and as fast as the E-clock rate when configured as slave.

#### 8.1 Functional Description

The central element in the SPI system is the block containing the shift register and the read data buffer. The system is single buffered in the transmit direction and double buffered in the receive direction. This means that new data for transmission cannot be written to the shifter until the previous transfer is complete; however, received data is transferred into a parallel read data buffer so the shifter is free to accept a second serial character. As long as the first character is read out of the read data buffer before the next serial character is ready to be transferred, no overrun condition occurs. A single MCU register address is used for reading data from the read data buffer, and for writing data to the shifter.

The SPI status block represents the SPI status functions (transfer complete, write collision, and mode fault) performed by the serial peripheral status register (SPSR). The SPI control block represents those functions that control the SPI system through the serial peripheral control register (SPCR).

Refer to **Figure 8-1**, which shows the SPI block diagram.

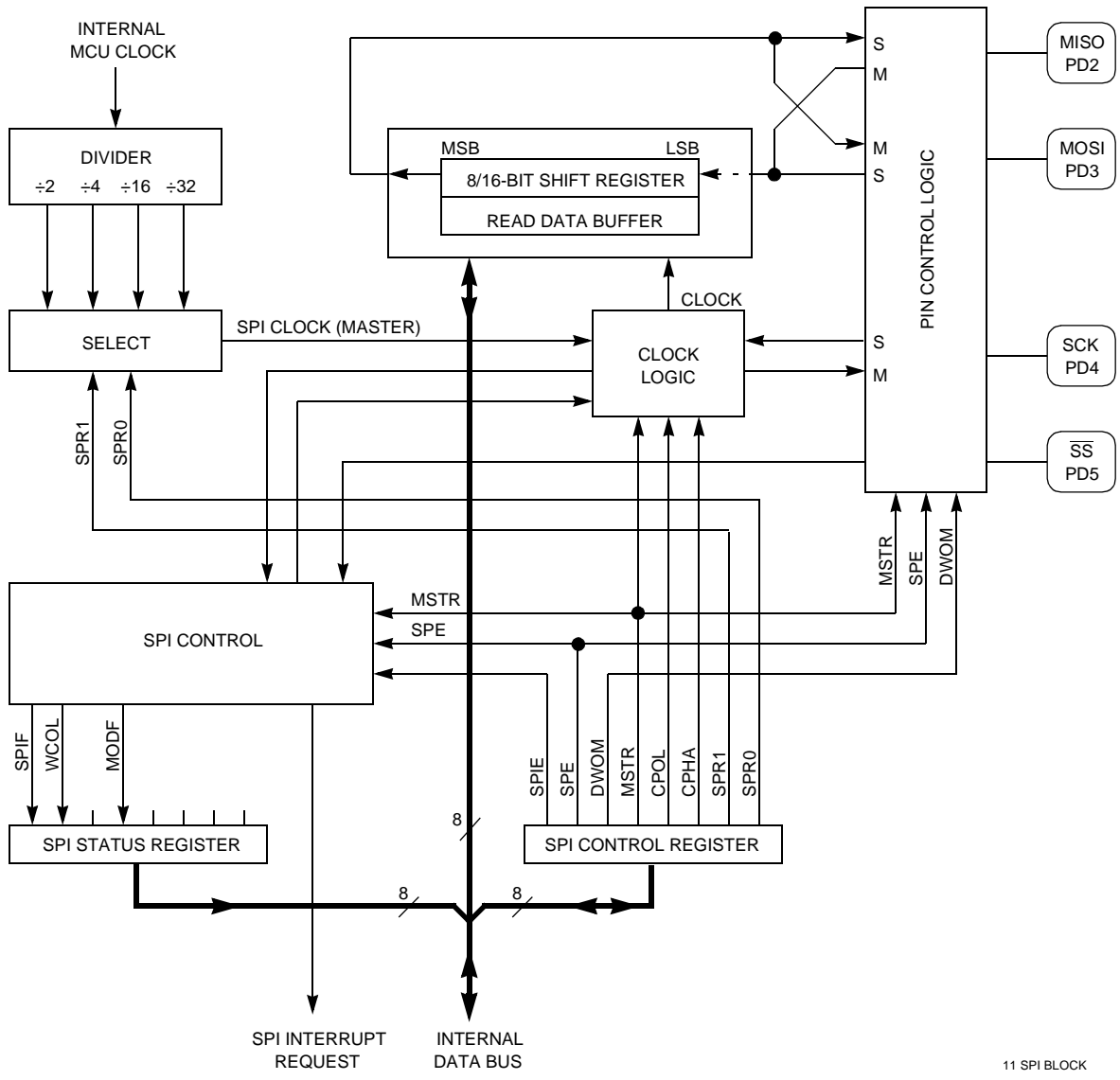

11 SPI BLOCK

Figure 8-1 SPI Block Diagram

### 8.2 SPI Transfer Formats

During an SPI transfer, data is simultaneously transmitted and received. A serial clock line synchronizes shifting and sampling of the information on the two serial data lines. A slave select line allows individual selection of a slave SPI device; slave devices that are not selected do not interfere with SPI bus activities. On a master SPI device, the select line can optionally be used to indicate a multiple master bus contention. Refer to **Figure 8-2**.

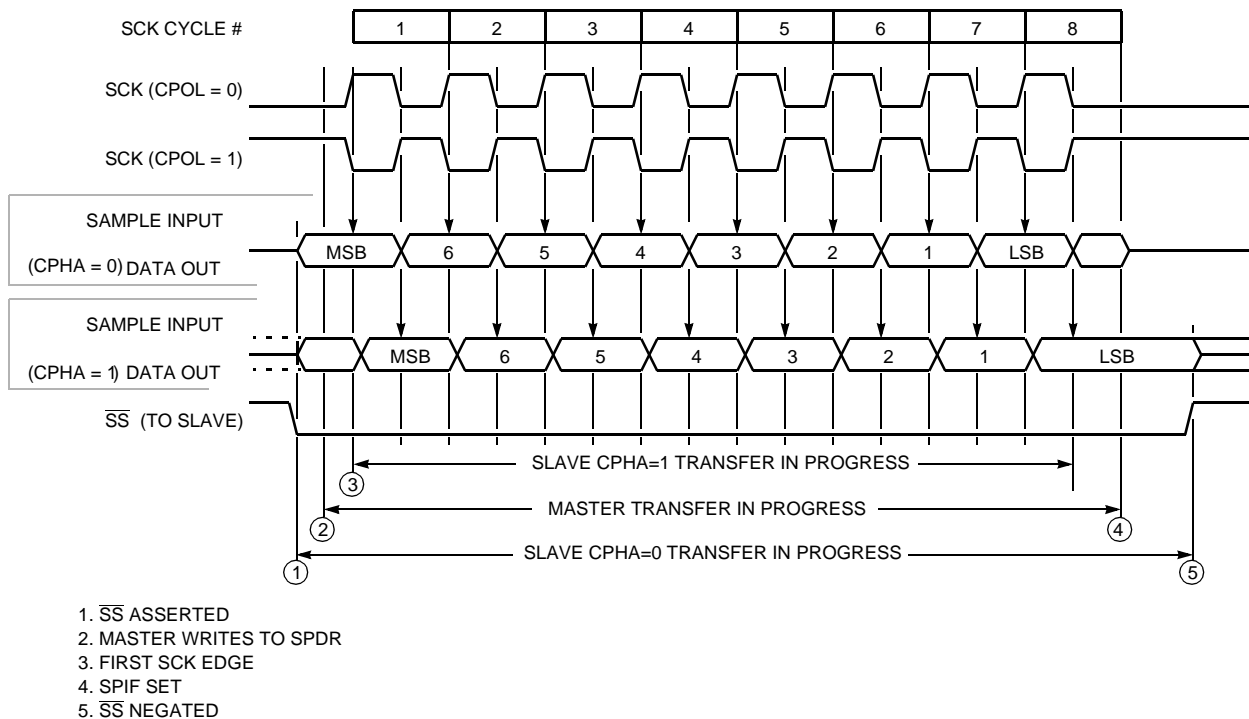

SPI TRANSFER FORMAT 1

Figure 8-2 SPI Transfer Format

### 8.2.1 Clock Phase and Polarity Controls

Software can select one of four combinations of serial clock phase and polarity using two bits in the SPI control register (SPCR). The clock polarity is specified by the CPOL control bit, which selects an active high or active low clock, and has no significant effect on the transfer format. The clock phase (CPHA) control bit selects one of two different transfer formats. The clock phase and polarity should be identical for the master SPI device and the communicating slave device. In some cases, the phase and polarity are changed between transfers to allow a master device to communicate with peripheral slaves having different requirements.

When CPHA equals zero, the slave select ( $\overline{SS}$ ) line must be negated and reasserted between each successive serial byte. Also, if the slave writes data to the SPI data register (SPDR) while  $\overline{SS}$  is active low, a write collision error results.

When CPHA equals one, the  $\overline{SS}$  line can remain low between successive transfers.

### 8.3 SPI Signals

The following paragraphs contain descriptions of the four SPI signals: master in slave out (MISO), master out slave in (MOSI), serial clock (SCK), and SS.

### 8.3.1 Master In Slave Out

MISO is one of two unidirectional serial data signals. It is an input to a master device and an output from a slave device. The MISO line of a slave device is placed in the high impedance state if the slave device is not selected.

### 8.3.2 Master Out Slave In

The MOSI line is the second of the two unidirectional serial data signals. It is an output from a master device and an input to a slave device. The master device places data on the MOSI line a half-cycle before the clock edge that the slave device uses to latch the data.

### 8.3.3 Serial Clock

SCK, an input to a slave device, is generated by the master device and synchronizes data movement in and out of the device through the MOSI and MISO lines. Master and slave devices are capable of exchanging a byte of information during a sequence of eight clock cycles.

There are four possible timing relationships that can be chosen by using control bits CPOL and CPHA in the serial peripheral control register (SPCR). Both master and slave devices must operate with the same timing. The SPI clock rate select bits, SPR[1:0], in the SPCR of the master device, select the clock rate. In a slave device, SPR[1:0] have no effect on the operation of the SPI.

### 8.3.4 Slave Select

The  $\overline{SS}$  input of a slave device must be externally asserted before a master device can exchange data with the slave device.  $\overline{SS}$  must be low before data transactions and must stay low for the duration of the transaction.

The  $\overline{SS}$  line of the master must be held high. If it goes low, a mode fault error flag (MODF) is set in the serial peripheral status register (SPSR). To disable the mode fault circuit, write a one in bit 5 of the port D data direction register. This sets the  $\overline{SS}$  pin to act as a general-purpose output. The other three lines are dedicated to the SPI whenever the serial peripheral interface is on.

The state of the master and slave CPHA bits affects the operation of  $\overline{SS}$ . CPHA settings should be identical for master and slave. When CPHA = 0, the shift clock is the OR of  $\overline{SS}$  with SCK. In this clock phase mode,  $\overline{SS}$  must go high between successive characters in an SPI message. When CPHA = 1,  $\overline{SS}$  can be left low between successive SPI characters. In cases where there is only one SPI slave MCU, its  $\overline{SS}$  line can be tied to  $V_{SS}$  as long as only CPHA = 1 clock mode is used.

## 8.4 SPI System Errors

Two system errors can be detected by the SPI system. The first type of error arises in a multiple-master system when more than one SPI device simultaneously tries to be a master. This error is called a mode fault. The second type of error, write collision,

indicates that an attempt was made to write data to the SPDR while a transfer was in progress.

When the SPI system is configured as a master and the  $\overline{SS}$  input line goes to active low, a mode fault error has occurred — usually because two devices have attempted to act as master at the same time. In cases where more than one device is concurrently configured as a master, there is a chance of contention between two pin drivers. For push-pull CMOS drivers, this contention can cause permanent damage. The mode fault attempts to protect the device by disabling the drivers. The MSTR control bit in the SPCR and all four DDRD control bits associated with the SPI are cleared. An interrupt is generated subject to masking by the SPIE control bit and the I bit in the CCR.

Other precautions may need to be taken to prevent driver damage. If two devices are made masters at the same time, mode fault does not help protect either one unless one of them selects the other as slave. The amount of damage possible depends on the length of time both devices attempt to act as master.

A write collision error occurs if the SPDR is written while a transfer is in progress. Because the SPDR is not double buffered in the transmit direction, writes to SPDR cause data to be written directly into the SPI shift register. Because this write corrupts any transfer in progress, a write collision error is generated. The transfer continues undisturbed, and the write data that caused the error is not written to the shifter.

A write collision is normally a slave error because a slave has no control over when a master initiates a transfer. A master knows when a transfer is in progress, so there is no reason for a master to generate a write-collision error, although the SPI logic can detect write collisions in both master and slave devices.

The SPI configuration determines the characteristics of a transfer in progress. For a master, a transfer begins when data is written to SPDR and ends when SPIF is set. For a slave with CPHA equal to zero, a transfer starts when  $\overline{SS}$  goes low and ends when  $\overline{SS}$  returns high. In this case, SPIF is set at the middle of the eighth SCK cycle when data is transferred from the shifter to the parallel data register, but the transfer is still in progress until  $\overline{SS}$  goes high. For a slave with CPHA equal to one, transfer begins when the SCK line goes to its active level, which is the edge at the beginning of the first SCK cycle. The transfer ends in a slave in which CPHA equals one when SPIF is set. For a slave, after a byte transfer, SCK must be in inactive state for at least 2 E-clock cycles before the next byte transfer begins.

## 8.5 SPI Registers

The three SPI registers, SPCR, SPSR, and SPDR, provide control, status, and data storage functions. Refer to the following information for a description of how these registers are organized.

### 8.5.1 Serial Peripheral Control

#### SPCR — Serial Peripheral Control Register

**\$0028**

	Bit 7	6	5	4	3	2	1	Bit 0
	SPIE	SPE	DWOM	MSTR	CPOL	CPHA	SPR1	SPR0
RESET:	0	0	0	0	0	1	U	U

#### SPIE — Serial Peripheral Interrupt Enable

0 = SPI interrupt disabled

1 = SPI interrupt enabled

#### SPE — Serial Peripheral System Enable

0 = SPI off

1 = SPI on

#### DWOM — Port D Wired-OR Mode

DWOM affects all six port D pins.

0 = Normal CMOS outputs

1 = Open-drain outputs

#### MSTR — Master Mode Select

0 = Slave mode

1 = Master mode

#### CPOL — Clock Polarity

When the clock polarity bit is cleared and data is not being transferred, the SCK pin of the master device has a steady state low value. When CPOL is set, SCK idles high. Refer to **Figure 8-2** and **8.2.1 Clock Phase and Polarity Controls**.

#### CPHA — Clock Phase

The clock phase bit, in conjunction with the CPOL bit, controls the clock-data relationship between master and slave. The CPHA bit selects one of two different clocking protocols. Refer to **Figure 8-2** and **8.2.1 Clock Phase and Polarity Controls**.

#### SPR1 and SPR0 — SPI Clock Rate Selects

These two serial peripheral rate bits select one of four baud rates to be used as SCK if the device is a master; however, they have no effect in the slave mode.

SPR[1:0]	E Clock Divide By	Frequency at E = 2 MHz (Baud)
0 0	2	1.0 MHz
0 1	4	500 kHz
1 0	16	125 kHz
1 1	32	62.5 kHz

### 8.5.2 Serial Peripheral Status

**SPSR** — Serial Peripheral Status Register

**\$0029**

	Bit 7	6	5	4	3	2	1	Bit 0
	SPIF	WCOL	0	MODF	0	0	0	0
RESET:	0	0	0	0	0	0	0	0

**SPIF** — SPI Transfer Complete Flag

SPIF is set upon completion of data transfer between the processor and the external device. If SPIF goes high, and if SPIE is set, a serial peripheral interrupt is generated. To clear the SPIF bit, read the SPSR with SPIF set, then access the SPDR. Unless SPSR is read (with SPIF set) first, attempts to write SPDR are inhibited.

**WCOL** — Write Collision

Clearing the WCOL bit is accomplished by reading the SPSR (with WCOL set) followed by an access of SPDR. Refer to **8.3.4 Slave Select** and **8.4 SPI System Errors**.

- 0 = No write collision
- 1 = Write collision

**Bit 5** — Not implemented

Always reads zero

**MODF** — Mode Fault

To clear the MODF bit, read the SPSR (with MODF set), then write to the SPCR. Refer to **8.3.4 Slave Select** and **8.4 SPI System Errors**.

- 0 = No mode fault
- 1 = Mode fault

**Bits [3:0]** — Not implemented

Always read zero

### 8.5.3 Serial Peripheral Data I/O

The SPDR is used when transmitting or receiving data on the serial bus. Only a write to this register initiates transmission or reception of a byte, and this only occurs in the master device. At the completion of transferring a byte of data, the SPIF status bit is set in both the master and slave devices.

A read of the SPDR is actually a read of a buffer. To prevent an overrun and the loss of the byte that caused the overrun, the first SPIF must be cleared by the time a second transfer of data from the shift register to the read buffer is initiated.

**SPDR** — SPI Data Register

**\$002A**

	Bit 7	6	5	4	3	2	1	Bit 0
	Bit 7	6	5	4	3	2	1	Bit 0

**NOTE**

SPI is double buffered in and single buffered out.



## SECTION 9 TIMING SYSTEM

The M68HC11 timing system is composed of five clock divider chains. The main clock divider chain includes a 16-bit free-running counter, which is driven by a programmable prescaler. The main timer's programmable prescaler provides one of the four clocking rates to drive the 16-bit counter. Two prescaler control bits select the prescale rate.

The prescaler output divides the system clock by 1, 4, 8, or 16. Taps off of this main clocking chain drive circuitry that generates the slower clocks used by the pulse accumulator, the real-time interrupt (RTI), and the computer operating properly (COP) watchdog subsystems, also described in this section. Refer to **Figure 9-1**.

All main timer system activities are referenced to this free-running counter. The counter begins incrementing from \$0000 as the MCU comes out of reset, and continues to the maximum count, \$FFFF. At the maximum count, the counter rolls over to \$0000, sets an overflow flag, and continues to increment. As long as the MCU is running in a normal operating mode, there is no way to reset, change, or interrupt the counting. The capture/compare subsystem features three input capture channels, four output compare channels, and one channel that can be selected to perform either input capture or output compare. Each of the three input capture functions has its own 16-bit input capture register (time capture latch) and each of the output compare functions has its own 16-bit compare register. All timer functions, including the timer overflow and RTI have their own interrupt controls and separate interrupt vectors.

The pulse accumulator contains an 8-bit counter and edge select logic. The pulse accumulator can operate in either event counting or gated time accumulation modes. During event counting mode, the pulse accumulator's 8-bit counter increments when a specified edge is detected on an input signal. During gated time accumulation mode, an internal clock source increments the 8-bit counter while an input signal has a predetermined logic level.

RTI is a programmable periodic interrupt circuit that permits pacing the execution of software routines by selecting one of four interrupt rates.

The COP watchdog clock input ( $E \div 2^{15}$ ) is tapped off of the free-running counter chain. The COP automatically times out unless it is serviced within a specific time by a program reset sequence. If the COP is allowed to time out, a reset is generated, which drives the RESET pin low to reset the MCU and the external system. Refer to **Table 9-1** for crystal related frequencies and periods.

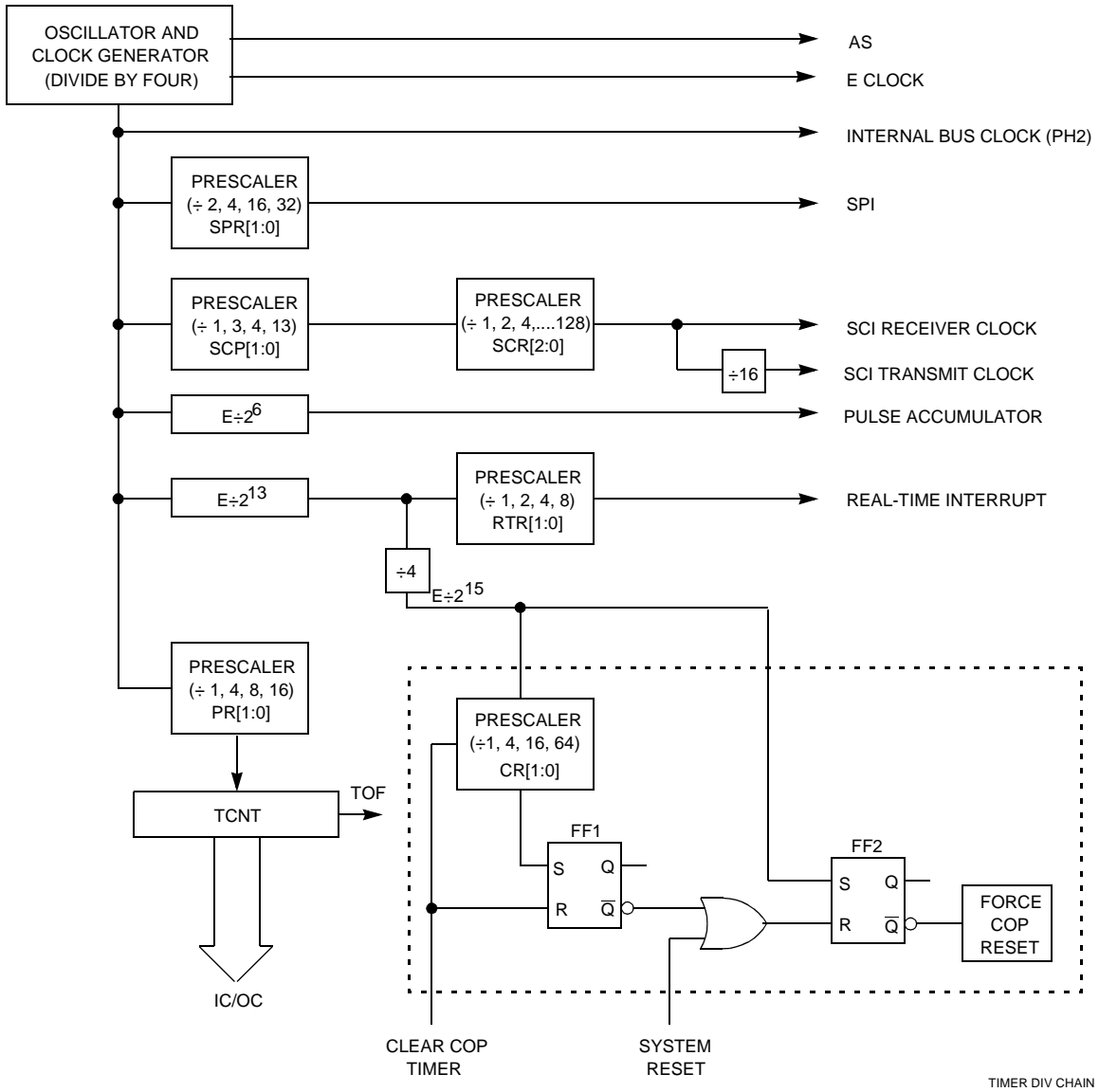

Figure 9-1 Timer Clock Divider Chains

**Table 9-1 Timer Summary**

Control Bits	XTAL Frequencies			
	4.0 MHz	8.0 MHz	12.0 MHz	Other Rates
	1.0 MHz	2.0 MHz	3.0 MHz	(E)
	1000 ns	500 ns	333 ns	(1/E)
PR[1:0]	Main Timer Count Rates			
0 0 1 count — overflow —	1.0 $\mu$ s 65.536 ms	500 ns 32.768 ms	333 ns 21.845 ms	(E/1) (E/2 <sup>16</sup> )
0 1 1 count — overflow —	4.0 $\mu$ s 262.14 ms	2.0 $\mu$ s 131.07 ms	1.333 $\mu$ s 87.381 ms	(E/4) (E/2 <sup>18</sup> )
1 0 1 count — overflow —	8.0 $\mu$ s 524.29 ms	4.0 $\mu$ s 262.14 ms	2.667 $\mu$ s 174.76 ms	(E/8) (E/2 <sup>19</sup> )
1 1 1 count — overflow —	16.0 $\mu$ s 1.049 s	8.0 $\mu$ s 524.29 ms	5.333 $\mu$ s 349.52 ms	(E/16) (E/2 <sup>20</sup> )

**9.1 Timer Structure**

**Figure 9-1** shows the capture/compare system block diagram. The port A pin control block includes logic for timer functions and for general-purpose I/O. For pins PA2, PA1, and PA0, this block contains both the edge-detection logic and the control logic that enables the selection of which edge triggers an input capture. The digital level on PA[2:0] can be read at any time (read PORTA register), even if the pin is being used for the input capture function. Pins PA[6:4] are used for either general-purpose output, or as output compare pins. Pin PA3 can be used for general-purpose I/O, input capture 4, output compare 5, or output compare 1. When one of these pins is being used for an output compare function, it cannot be written directly as if it were a general-purpose output. Each of the output compare functions (OC5–OC2) is related to one of the port A output pins. Output compare one (OC1) has extra control logic, allowing it optional control of any combination of the PA[7:3] pins. The PA7 pin can be used as a general-purpose I/O pin, as an input to the pulse accumulator, or as an OC1 output pin.

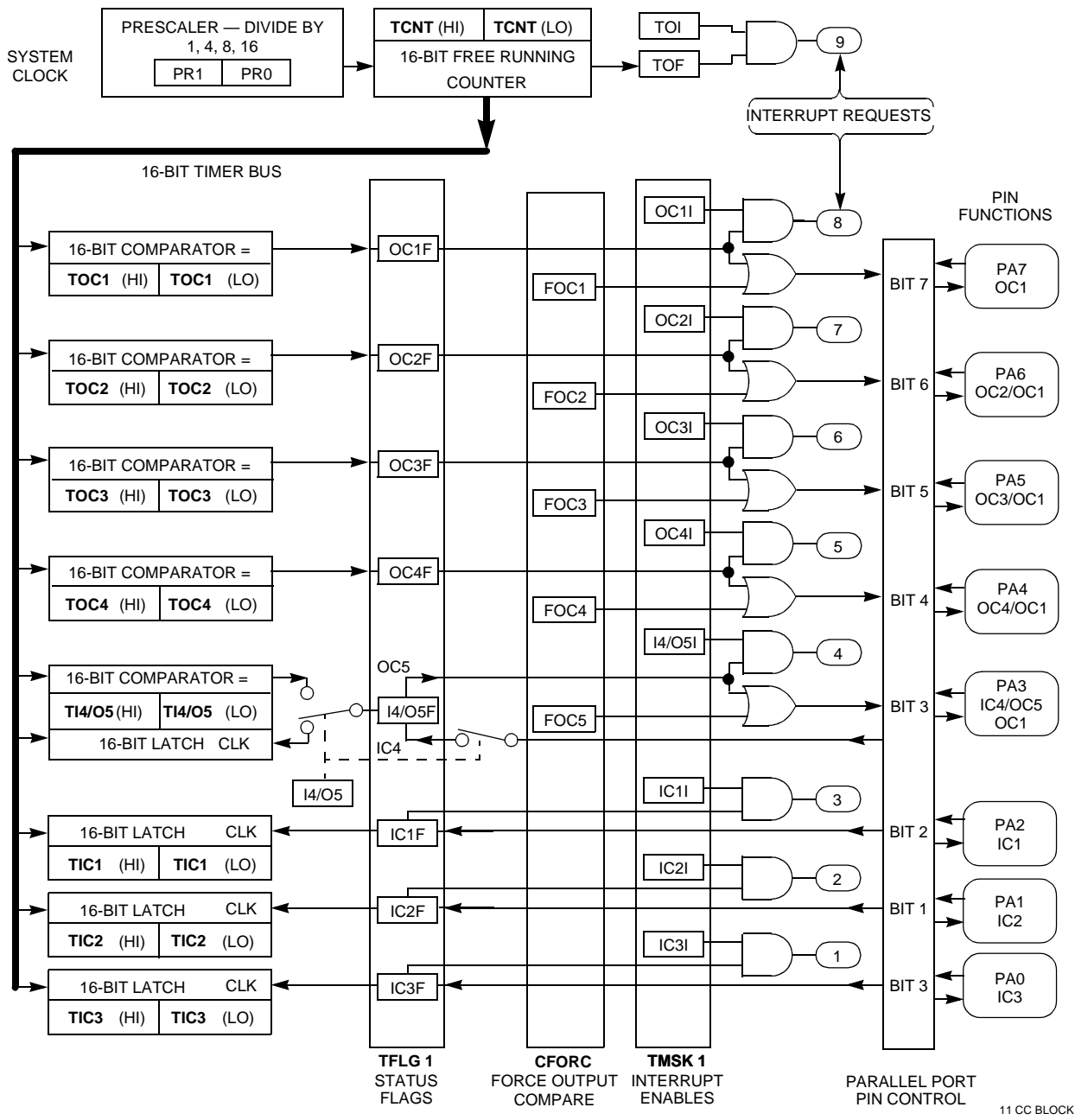

Figure 9-2 Capture/Compare Block Diagram

### 9.2 Input Capture

The input capture function records the time an external event occurs by latching the value of the free-running counter when a selected edge is detected at the associated timer input pin. Software can store latched values and use them to compute the periodicity and duration of events. For example, by storing the times of successive edges of an incoming signal, software can determine the period and pulse width of a signal. To measure period, two successive edges of the same polarity are captured. To measure pulse width, two alternate polarity edges are captured.

In most cases, input capture edges are asynchronous to the internal timer counter, which is clocked relative to the PH2 clock. These asynchronous capture requests are synchronized to PH2 so that the latching occurs on the opposite half cycle of PH2 from when the timer counter is being incremented. This synchronization process introduces a delay from when the edge occurs to when the counter value is detected. Because these delays offset each other when the time between two edges is being measured, the delay can be ignored. When an input capture is being used with an output compare, there is a similar delay between the actual compare point and when the output pin changes state.

The control and status bits that implement the input capture functions are contained in the PACTL, TCTL2, TMSK1, and TFLG1 registers.

To configure port A bit 3 as an input capture, clear the DDRA3 bit of the PACTL register. Note that this bit is cleared out of reset. To enable PA3 as the fourth input capture, set the I4/O5 bit in the PACTL register. Otherwise, PA3 is configured as a fifth output compare out of reset, with bit I4/O5 being cleared. If the DDRA3 bit is set (configuring PA3 as an output), and IC4 is enabled, then writes to PA3 cause edges on the pin to result in input captures. Writing to TI4/O5 has no effect when the TI4/O5 register is acting as IC4.

### 9.2.1 Timer Control 2 Register

Use the control bits of this register to program input capture functions to detect a particular edge polarity on the corresponding timer input pin. Each of the input capture functions can be independently configured to detect rising edges only, falling edges only, any edge (rising or falling), or to disable the input capture function. The input capture functions operate independently of each other and can capture the same TCNT value if the input edges are detected within the same timer count cycle.

#### TCTL2 — Timer Control 2 \$0021

	Bit 7	6	5	4	3	2	1	Bit 0
	EDG4B	EDG4A	EDG1B	EDG1A	EDG2B	EDG2A	EDG3B	EDG3A
RESET:	0	0	0	0	0	0	0	0

#### EDGxB and EDGxA — Input Capture Edge Control

There are four pairs of these bits. Each pair is cleared to zero by reset and must be encoded to configure the corresponding input capture edge detector circuit. IC4 functions only if the I4/O5 bit in the PACTL register is set. Refer to **Table 9-2** for timer control configuration.

**Table 9-2 Timer Control Configuration**

EDGxB	EDGxA	Configuration
0	0	Capture disabled
0	1	Capture on rising edges only
1	0	Capture on falling edges only
1	1	Capture on any edge

### 9.2.2 Timer Input Capture Registers

When an edge has been detected and synchronized, the 16-bit free-running counter value is transferred into the input capture register pair as a single 16-bit parallel transfer. Timer counter value captures and timer counter incrementing occur on opposite half-cycles of the phase two clock so that the count value is stable whenever a capture occurs. The TICx registers are not affected by reset. Input capture values can be read from a pair of 8-bit read-only registers. A read of the high-order byte of an input capture register pair inhibits a new capture transfer for one bus cycle. If a double-byte read instruction, such as LDD, is used to read the captured value, coherency is assured. When a new input capture occurs immediately after a high-order byte read, transfer is delayed for an additional cycle but the value is not lost.

#### TIC1–TIC3 — Timer Input Capture

**\$0010–\$0015**

\$0010	Bit 15	14	13	12	11	10	9	Bit 8	TIC1 (High)
\$0011	Bit 7	6	5	4	3	2	1	Bit 0	TIC1 (Low)
\$0012	Bit 15	14	13	12	11	10	9	Bit 8	TIC2 (High)
\$0013	Bit 7	6	5	4	3	2	1	Bit 0	TIC2 (Low)
\$0014	Bit 15	14	13	12	11	10	9	Bit 8	TIC3 (High)
\$0015	Bit 7	6	5	4	3	2	1	Bit 0	TIC3 (Low)

RESET: Input capture registers not affected by reset.

### 9.2.3 Timer Input Capture 4/Output Compare 5 Register

Use TI4/O5 as either an input capture register or an output compare register, depending on the function chosen for the I4/O5 pin. To enable it as an input capture pin, set the I4/O5 bit in the pulse accumulator control register (PACTL) to logic level one. To use it as an output compare register, set the I4/O5 bit to a logic level zero. Refer to **9.6 Pulse Accumulator**.

#### TI4/O5 — Timer Input Capture 4/Output Compare 5

**\$001E, \$001F**

\$001E	Bit 15	14	13	12	11	10	9	Bit 8	TI4/O5 (High)
\$001F	Bit 7	6	5	4	3	2	1	Bit 0	TI4/O5 (Low)

RESET: All I4/O5 register pairs reset to ones (\$FFFF).

### 9.3 Output Compare

Use the output compare (OC) function to program an action to occur at a specific time — when the 16-bit counter reaches a specified value. For each of the five output compare functions, there is a separate 16-bit compare register and a dedicated 16-bit comparator. The value in the compare register is compared to the value of the free-running counter on every bus cycle. When the compare register matches the counter value, an output compare status flag is set. The flag can be used to initiate the automatic actions for that output compare function.

To produce a pulse of a specific duration, write to the output compare register a value representing the time the leading edge of the pulse is to occur. The output compare circuit is configured to set the appropriate output either high or low, depending on the

polarity of the pulse being produced. After a match occurs, the output compare register is reprogrammed to change the output pin back to its inactive level at the next match. A value representing the width of the pulse is added to the original value, and then written to the output compare register. Because the pin state changes occur at specific values of the free-running counter, the pulse width can be controlled accurately at the resolution of the free-running counter, independent of software latencies. To generate an output signal of a specific frequency and duty cycle, repeat this pulse-generating procedure.

There are four 16-bit read/write output compare registers: TOC1, TOC2, TOC3, and TOC4, and the TI4/O5 register, which functions under software control as either IC4 or OC5. Each of the OC registers is set to \$FFFF on reset. A value written to an OC register is compared to the free-running counter value during each E-clock cycle. If a match is found, the particular output compare flag is set in timer interrupt flag register 1 (TFLG1). If that particular interrupt is enabled in the timer interrupt mask register 1 (TMSK1), an interrupt is generated. In addition to an interrupt, a specified action can be initiated at one or more timer output pins. For OC5–OC2, the pin action is controlled by pairs of bits (OMx and OLx) in the TCTL1 register. The output action is taken on each successful compare, regardless of whether or not the OCxF flag in the TFLG1 register was previously cleared.

OC1 is different from the other output compares in that a successful OC1 compare can affect any or all five of the OC pins. The OC1 output action taken when a match is found is controlled by two 8-bit registers with three bits unimplemented: the output compare 1 mask register, OC1M, and the output compare 1 data register, OC1D. OC1M specifies which port A outputs are to be used, and OC1D specifies what data is placed on these port pins.

### 9.3.1 Timer Output Compare Registers

All output compare registers are 16-bit read-write. Each is initialized to \$FFFF at reset. If an output compare register is not used for an output compare function, it can be used as a storage location. A write to the high-order byte of an output compare register pair inhibits the output compare function for one bus cycle. This inhibition prevents inappropriate subsequent comparisons. Coherency requires a complete 16-bit read or write. However, if coherency is not needed, byte accesses can be used.

For output compare functions, write a comparison value to output compare registers TOC1–TOC4 and TI4/O5. When TCNT value matches the comparison value, specified pin actions occur.

**TOC1–TOC4 — Timer Output Compare**

**\$0016–\$001D**

\$0016	Bit 15	14	13	12	11	10	9	Bit 8	TOC1 (High)
\$0017	Bit 7	6	5	4	3	2	1	Bit 0	TOC1 (Low)
\$0018	Bit 15	14	13	12	11	10	9	Bit 8	TOC2 (High)
\$0019	Bit 7	6	5	4	3	2	1	Bit 0	TOC2 (Low)
\$001A	Bit 15	14	13	12	11	10	9	Bit 8	TOC3 (High)
\$001B	Bit 7	6	5	4	3	2	1	Bit 0	TOC3 (Low)
\$001C	Bit 15	14	13	12	11	10	9	Bit 8	TOC4 (High)
\$001D	Bit 7	6	5	4	3	2	1	Bit 0	TOC4 (Low)

All TOCx register pairs reset to ones (\$FFFF)

**TI4/O5 — Timer Input Capture 4/Output Compare 5**

**\$001E, \$001F**

Refer to **9.2.3 Timer Input Capture 4/Output Compare 5 Register**.

**9.3.2 Timer Compare Force Register**

The CFORC register allows forced early compares. FOC[1:5] correspond to the five output compares. These bits are set for each output compare that is to be forced. The action taken as a result of a forced compare is the same as if there were a match between the OCx register and the free-running counter, except that the corresponding interrupt status flag bits are not set. The forced channels trigger their programmed pin actions to occur at the next timer count transition after the write to CFORC.

The CFORC bits should not be used on an output compare function that is programmed to toggle its output on a successful compare because a normal compare that occurs immediately before or after the force can result in an undesirable operation.

**CFORC — Timer Compare Force**

**\$000B**

	Bit 7	6	5	4	3	2	1	Bit 0
	FOC1	FOC2	FOC3	FOC4	FOC5	0	0	0
RESET:	0	0	0	0	0	0	0	0

**FOC1–FOC5 — Write Ones to Force Compare(s)**

0 = Not affected

1 = Output x action occurs

Bits [2:0] — Not implemented, always read zero

**9.3.3 Output Compare Mask Registers**

Use OC1M with OC1 to specify the bits of port A that are affected by a successful OC1 compare. The bits of the OC1M register correspond to PA[7:3].

**OC1M** — Output Compare 1 Mask

**\$000C**

	Bit 7	6	5	4	3	2	1	Bit 0
	OC1M7	OC1M6	OC1M5	OC1M4	OC1M3	0	0	0
RESET:	0	0	0	0	0	0	0	0

**OC1M7–OC1M3** — Output Compare Masks

0 = OC1 is disabled

1 = OC1 is enabled to control the corresponding pin of port A

Bits [2:0] — Not implemented; always read zero

Set bit(s) to enable OC1 to control corresponding pin(s) of port A.

**9.3.4 Output Compare 1 Data Register**

Use this register with OC1 to specify the data that is to be stored on the affected pin of port A after a successful OC1 compare. When a successful OC1 compare occurs, a data bit in OC1D is stored in the corresponding bit of port A for each bit that is set in OC1M.

**OC1D** — Output Compare 1 Data

**\$000D**

	Bit 7	6	5	4	3	2	1	Bit 0
	OC1D7	OC1D6	OC1D5	OC1D4	OC1D3	0	0	0
RESET:	0	0	0	0	0	0	0	0

If OC1M<sub>x</sub> is set, data in OC1D<sub>x</sub> is output to port A bit x on successful OC1 compares.

Bits [2:0] — Not implemented; always read zero

**9.3.5 Timer Counter Register**

The 16-bit read-only TCNT register contains the prescaled value of the 16-bit timer. A full counter read addresses the most significant byte (MSB) first. A read of this address causes the least significant byte (LSB) to be latched into a buffer for the next CPU cycle so that a double-byte read returns the full 16-bit state of the counter at the time of the MSB read cycle.

**TCNT** — Timer Counter

**\$000E, \$000F**

\$000E	Bit 15	14	13	12	11	10	9	Bit 8	TCNT (High)
\$000F	Bit 7	6	5	4	3	2	1	Bit 0	TCNT (Low)

TCNT resets to \$0000.

In normal modes, TCNT is read-only.

**9.3.6 Timer Control 1 Register**

The bits of this register specify the action taken as a result of a successful OC<sub>x</sub> compare.

**TCTL1** — Timer Control 1

**\$0020**

	Bit 7	6	5	4	3	2	1	Bit 0
	OM2	OL2	OM3	OL3	OM4	OL4	OM5	OL5
RESET:	0	0	0	0	0	0	0	0

OM[2:5] — Output Mode

OL[2:5] — Output Level

These control bit pairs are encoded to specify the action taken after a successful OCx compare. OC5 functions only if the I4/O5 bit in the PACTL register is clear. Refer to the following table for the coding.

OMx	OLx	Action Taken on Successful Compare
0	0	Timer disconnected from output pin logic
0	1	Toggle OCx output line
1	0	Clear OCx output line to 0
1	1	Set OCx output line to 1

**9.3.7 Timer Interrupt Mask 1 Register**

Use this 8-bit register to enable or inhibit the timer input capture and output compare interrupts.

**TMSK1** — Timer Interrupt Mask 1

**\$0022**

	Bit 7	6	5	4	3	2	1	Bit 0
	OC1I	OC2I	OC3I	OC4I	I4/O5I	IC1I	IC2I	IC3I
RESET:	0	0	0	0	0	0	0	0

OC1I–OC4I — Output Compare x Interrupt Enable

If the OCxI enable bit is set when the OCxF flag bit is set, a hardware interrupt sequence is requested.

I4/O5I — Input Capture 4 or Output Compare 5 Interrupt Enable

When I4/O5 in PACTL is one, I4/O5I is the input capture 4 interrupt enable bit. When I4/O5 in PACTL is zero, I4/O5I is the output compare 5 interrupt enable bit.

IC1I–IC3I — Input Capture x Interrupt Enable

If the ICxI enable bit is set when the ICxF flag bit is set, a hardware interrupt sequence is requested.

**NOTE**

Bits in TMSK1 correspond bit for bit with flag bits in TFLG1. Ones in TMSK1 enable the corresponding interrupt sources.

**9.3.8 Timer Interrupt Flag 1 Register**

Bits in this register indicate when timer system events have occurred. Coupled with the bits of TMSK1, the bits of TFLG1 allow the timer subsystem to operate in either a

polled or interrupt driven system. Each bit of TFLG1 corresponds to a bit in TMSK1 in the same position.

**TFLG1 — Timer Interrupt Flag 1 \$0023**

	Bit 7	6	5	4	3	2	1	Bit 0
	OC1F	OC2F	OC3F	OC4F	I4/O5F	IC1F	IC2F	IC3F
RESET:	0	0	0	0	0	0	0	0

Clear flags by writing a one to the corresponding bit position(s).

**OC1F–OC5F — Output Compare x Flag**

Set each time the counter matches output compare x value

**I4/O5F — Input Capture 4/Output Compare 5 Flag**

Set by IC4 or OC5, depending on the function enabled by I4/O5 bit in PACTL

**IC1F–IC3F — Input Capture x Flag**

Set each time a selected active edge is detected on the ICx input line

**9.3.9 Timer Interrupt Mask 2 Register**

Use this 8-bit register to enable or inhibit timer overflow and real-time interrupts. The timer prescaler control bits are included in this register.

**TMSK2 — Timer Interrupt Mask 2 \$0024**

	Bit 7	6	5	4	3	2	1	Bit 0
	TOI	RTII	PAOVI	PAII	0	0	PR1	PR0
RESET:	0	0	0	0	0	0	0	0

**TOI — Timer Overflow Interrupt Enable**

0 = TOF interrupts disabled

1 = Interrupt requested when TOF is set to one

**RTII — Real-time Interrupt Enable**

Refer to **9.4 Real-Time Interrupt**.

**PAOVI — Pulse Accumulator Overflow Interrupt Enable**

Refer to **9.6 Pulse Accumulator**.

**PAII — Pulse Accumulator Input Edge Interrupt Enable**

Refer to **9.6 Pulse Accumulator**.

**NOTE**

Bits in TMSK2 correspond bit for bit with flag bits in TFLG2. Ones in TMSK2 enable the corresponding interrupt sources.

**PR[1:0] — Timer Prescaler Select**

These bits are used to select the prescaler divide-by ratio. In normal modes, PR[1:0] can only be written once, and the write must be within 64 cycles after reset. Refer to **Table 9-1** for specific timing values.

PR[1:0]	Prescaler
0 0	1
0 1	4
1 0	8
1 1	16

**9.3.10 Timer Interrupt Flag 2 Register**

Bits in this register indicate when certain timer system events have occurred. Coupled with the four high-order bits of TMSK2, the bits of TFLG2 allow the timer subsystem to operate in either a polled or interrupt driven system. Each bit of TFLG2 corresponds to a bit in TMSK2 in the same position.

**TFLG2 — Timer Interrupt Flag 2**

**\$0025**

	Bit 7	6	5	4	3	2	1	Bit 0
	TOF	RTIF	PAOVF	PAIF	0	0	0	0
RESET:	0	0	0	0	0	0	0	0

Clear flags by writing a one to the corresponding bit position(s).

**TOF — Timer Overflow Interrupt Flag**

Set when TCNT changes from \$FFFF to \$0000

**RTIF — Real-Time (Periodic) Interrupt Flag**

Refer to **9.4 Real-Time Interrupt**.

**PAOVF — Pulse Accumulator Overflow Interrupt Flag**

Refer to **9.6 Pulse Accumulator**.

**PAIF — Pulse Accumulator Input Edge Interrupt Flag**

Refer to **9.6 Pulse Accumulator**.

**Bits [3:0]— Not implemented**

Always read zero

**9.4 Real-Time Interrupt**

The real-time interrupt feature, used to generate hardware interrupts at a fixed periodic rate, is controlled and configured by two bits (RTR1 and RTR0) in the pulse accumulator control (PACTL) register. The RTII bit in the TMSK2 register enables the interrupt capability. The four different rates available are a product of the MCU oscillator frequency and the value of bits RTR[1:0]. Refer to the following table, which shows the periodic real-time interrupt rates.

RTR[1:0]	E = 1 MHz	E = 2 MHz	E = 3 MHz	E = X MHz
0 0	2.731 ms	4.096 ms	8.192 ms	(E/2 <sup>13</sup> )
0 1	5.461 ms	8.192 ms	16.384 ms	(E/2 <sup>14</sup> )
1 0	10.923 ms	16.384 ms	32.768 ms	(E/2 <sup>15</sup> )
1 1	21.845 ms	32.768 ms	65.536 ms	(E/2 <sup>16</sup> )

The clock source for the RTI function is a free-running clock that cannot be stopped or interrupted except by reset. This clock causes the time between successive RTI time-outs to be a constant that is independent of the software latencies associated with flag clearing and service. For this reason, an RTI period starts from the previous time-out, not from when RTIF is cleared.

Every time-out causes the RTIF bit in TFLG2 to be set, and if RTII is set, an interrupt request is generated. After reset, one entire real-time interrupt period elapses before the RTIF flag is set for the first time. Refer to the TMSK2, TFLG2, and PACTL registers.

### 9.4.1 Timer Interrupt Mask 2 Register

This register contains the real-time interrupt enable bits.

#### TMSK2 — Timer Interrupt Mask 2

**\$0024**

	Bit 7	6	5	4	3	2	1	Bit 0
	TOI	RTII	PAOVI	PAII	0	0	PR1	PR0
RESET:	0	0	0	0	0	0	0	0

TOI — Timer Overflow Interrupt Enable  
Refer to **9.3 Output Compare**.

RTII — Real-time Interrupt Enable  
0 = RTIF interrupts disabled  
1 = Interrupt requested when RTIF is set to one

PAOVI — Pulse Accumulator Overflow Interrupt Enable  
Refer to **9.6 Pulse Accumulator**.

PAII — Pulse Accumulator Input Edge  
Refer to **9.6 Pulse Accumulator**.

#### NOTE

Bits in TMSK2 correspond bit for bit with flag bits in TFLG2. Ones in TMSK2 enable the corresponding interrupt sources.

### 9.4.1 Timer Interrupt Flag 2 Register

Bits of this register indicate the occurrence of timer system events. Coupled with the four high-order bits of TMSK2, the bits of TFLG2 allow the timer subsystem to operate in either a polled or interrupt driven system. Each bit of TFLG2 corresponds to a bit in TMSK2 in the same position.

**TFLG2** — Timer Interrupt Flag 2 **\$0025**

	Bit 7	6	5	4	3	2	1	Bit 0
	TOF	RTIF	PAOVF	PAIF	0	0	0	0
RESET:	0	0	0	0	0	0	0	0

Clear flags by writing a one to the corresponding bit position(s).

**TOF** — Timer Overflow Interrupt Flag

Set when TCNT changes from \$FFFF to \$0000

**RTIF** — Real-Time Interrupt Flag

The RTIF status bit is automatically set to one at the end of every RTI period. To clear RTIF, write a byte to TFLG2 with bit 6 set.

**PAOVF** — Pulse Accumulator Overflow Interrupt Flag

Refer to **9.6 Pulse Accumulator**.

**PAIF** — Pulse Accumulator Input Edge Interrupt Flag

Refer to **9.6 Pulse Accumulator**.

**Bits [3:0]** — Not implemented

Always read zero

**9.4.2 Pulse Accumulator Control Register**

Bits RTR[1:0] of this register select the rate for the real-time interrupt system. Bit DDRA3 determines whether Port A bit three is an input or an output when used for general-purpose I/O. The remaining bits control the pulse accumulator.

**PACTL** — Pulse Accumulator Control **\$0026**

	Bit 7	6	5	4	3	2	1	Bit 0
	DDRA7	PAEN	PAMOD	PEDGE	DDRA3	I4/O5	RTR1	RTR0
RESET:	0	0	0	0	0	0	0	0

**DDRA7** — Data Direction Control for Port A Bit 7

Refer to **9.6 Pulse Accumulator**.

**PAEN** — Pulse Accumulator System Enable

Refer to **9.6 Pulse Accumulator**.

**PAMOD** — Pulse Accumulator Mode

Refer to **9.6 Pulse Accumulator**.

**PEDGE** — Pulse Accumulator Edge Control

Refer to **9.6 Pulse Accumulator**.

**DDRA3** — Data Direction Register for Port A Bit 3

Refer to **SECTION 6 PARALLEL I/O**.

**I4/O5** — Input Capture 4/Output Compare 5

Refer to **9.2 Input Capture**.

**RTR[1:0] — RTI Interrupt Rate Select**

These two bits determine the rate at which the RTI system requests interrupts. The RTI system is driven by an E divided by  $2^{13}$  rate clock that is compensated so it is independent of the timer prescaler. These two control bits select an additional division factor.

RTR[1:0]	E = 1 MHz	E = 2 MHz	E = 3 MHz	E = X MHz
0 0	2.731 ms	4.096 ms	8.192 ms	$(E/2^{13})$
0 1	5.461 ms	8.192 ms	16.384 ms	$(E/2^{14})$
1 0	10.923 ms	16.384 ms	32.768 ms	$(E/2^{15})$
1 1	21.845 ms	32.768 ms	65.536 ms	$(E/2^{16})$

**9.5 Computer Operating Properly Watchdog Function**

The clocking chain for the COP function, tapped off of the main timer divider chain, is only superficially related to the main timer system. The CR[1:0] bits in the OPTION register and the NOCOP bit in the CONFIG register determine the status of the COP function. Refer to **SECTION 5 RESETS AND INTERRUPTS** for a more detailed discussion of the COP function.

**9.6 Pulse Accumulator**

The MC68HC11D3 has an 8-bit counter that can be configured to operate either as a simple event counter, or for gated time accumulation, depending on the state of the PAMOD bit in the PACTL register. Refer to the pulse accumulator block diagram, **Figure 9-3**.

In the event counting mode, the 8-bit counter is clocked to increasing values by an external pin. The maximum clocking rate for the external event counting mode is the E clock divided by two. In gated time accumulation mode, a free-running E-clock  $\div 64$  signal drives the 8-bit counter, but only while the external PAI pin is activated. Refer to **Table 9-3**. The pulse accumulator counter can be read or written at any time.

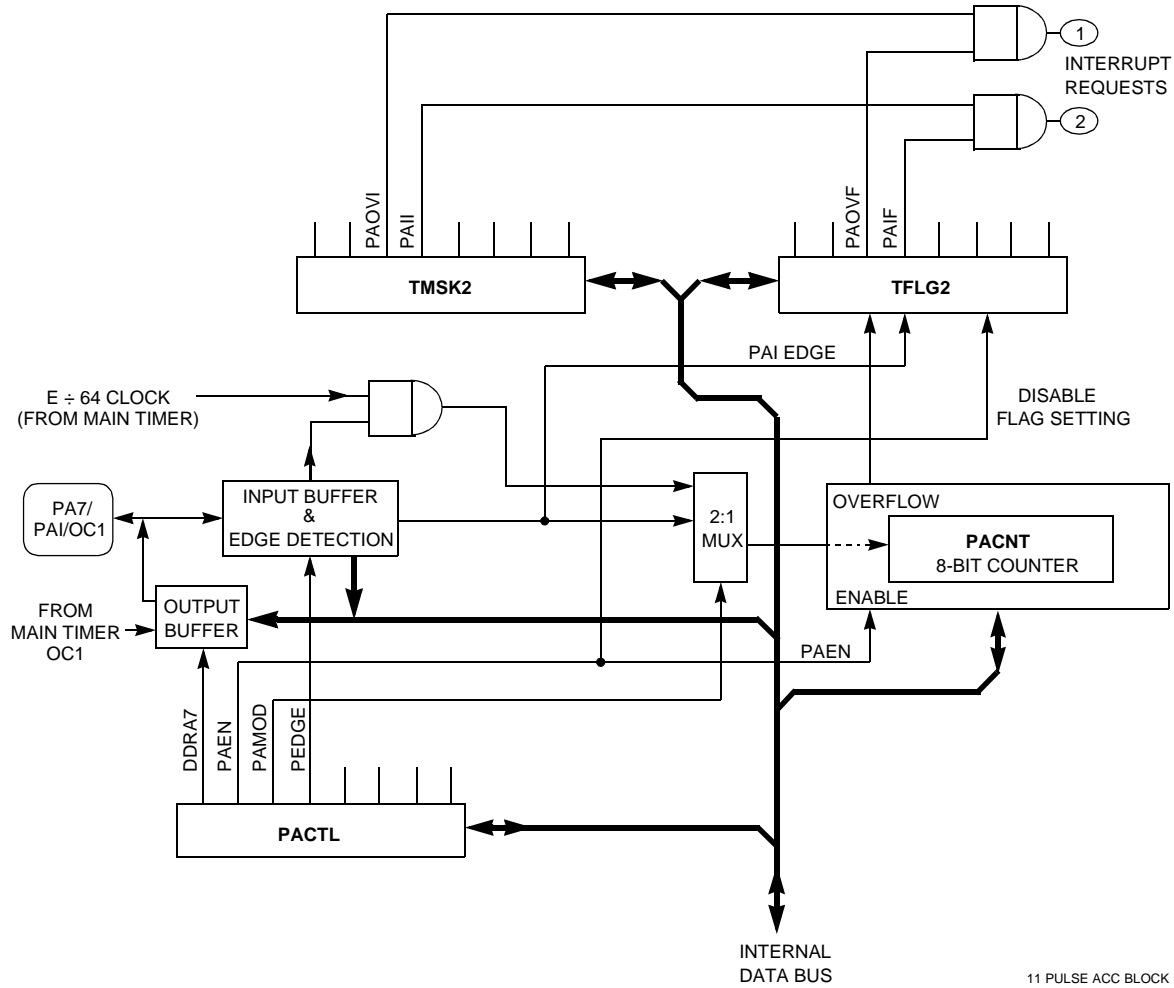

Figure 9-3 Pulse Accumulator

Table 9-3 Pulse Accumulator Timing

	Selected Crystal	Common XTAL Frequencies		
		4.0 MHz	8.0 MHz	12.0 MHz
CPU Clock	(E)	1.0 MHz	2.0 MHz	3.0 MHz
Cycle Time	(1/E)	1000 ns	500 ns	333 ns
Pulse Accumulator (in Gated Mode)				
(E/2 <sup>6</sup> )	1 count -	64.0 μs	32.0 μs	21.33 μs
(E/2 <sup>14</sup> )	overflow -	16.384 ms	8.192 ms	5.461 ms

Pulse accumulator control bits are also located within two timer registers, TMSK2 and TFLG2, as described in the following paragraphs.

### 9.6.1 Pulse Accumulator Control Register

Four of this register's bits control an 8-bit pulse accumulator system. Another bit enables either the OC5 function or the IC4 function, while two other bits select the rate for the real-time interrupt system.

**PACTL** — Pulse Accumulator Control **\$0026**

	Bit 7	6	5	4	3	2	1	Bit 0
	DDRA7	PAEN	PAMOD	PEDGE	DDRA3	I4/O5	RTR1	RTR0
RESET:	0	0	0	0	0	0	0	0

#### DDRA7 — Data Direction Control for Port A Bit 7

The pulse accumulator uses port A bit 7 as the PAI input, but the pin can also be used as general-purpose I/O or as an output compare. Note that even when port A bit 7 is configured as an output, the pin still drives the input to the pulse accumulator. Refer to **SECTION 6 PARALLEL I/O** for more information.

#### PAEN — Pulse Accumulator System Enable

- 0 = Pulse accumulator disabled
- 1 = Pulse accumulator enabled

#### PAMOD — Pulse Accumulator Mode

- 0 = Event counter
- 1 = Gated time accumulation

#### PEDGE — Pulse Accumulator Edge Control

This bit has different meanings depending on the state of the PAMOD bit, as shown in the following table:

PAMOD	PEDGE	Action on Clock
0	0	PAI Falling Edge Increments the Counter.
0	1	PAI Rising Edge Increments the Counter.
1	0	A Zero on PAI Inhibits Counting.
1	1	A One on PAI Inhibits Counting.

#### DDRA3 — Data Direction Register for Port A Bit 3

Refer to **SECTION 6 PARALLEL I/O**.

#### I4/O5 — Input Capture 4/Output Compare 5

Refer to **9.2 Input Capture**.

#### RTR[1:0] — RTI Interrupt Rate Selects

Refer to **9.4 Real-Time Interrupt**.

### 9.6.2 Pulse Accumulator Count Register

This 8-bit read/write register contains the count of external input events at the PAI input, or the accumulated count. The counter is not affected by reset and can be read or written at any time. Counting is synchronized to the internal PH2 clock so that incrementing and reading occur during opposite half cycles.

**PACNT — Pulse Accumulator Count**

**\$0027**

Bit 7	6	5	4	3	2	1	Bit 0
Bit 7	6	5	4	3	2	1	Bit 0

**9.6.3 Pulse Accumulator Status and Interrupt Bits**

The pulse accumulator control bits, PAOVI and PAII, PAOVF, and PAIF are located within timer registers TMSK2 and TFLG2.

**PAOVI and PAOVF — Pulse Accumulator Interrupt Enable and Overflow Flag**

The PAOVF status bit is set each time the pulse accumulator count rolls over from \$FF to \$00. To clear this status bit, write a one in the corresponding data bit position (bit 5) of the TFLG2 register. The PAOVI control bit allows configuring the pulse accumulator overflow for polled or interrupt-driven operation and does not affect the state of PAOVF. When PAOVI is zero, pulse accumulator overflow interrupts are inhibited, and the system operates in a polled mode, which requires PAOVF to be polled by user software to determine when an overflow has occurred. When the PAOVI control bit is set, a hardware interrupt request is generated each time PAOVF is set. Before leaving the interrupt service routine, software must clear PAOVF by writing to the TFLG2 register.

**PAII and PAIF — Pulse Accumulator Input Edge Interrupt Enable and Flag**

The PAIF status bit is automatically set each time a selected edge is detected at the PA7/PAI/OC1 pin. To clear this status bit, write to the TFLG2 register with a one in the corresponding data bit position (bit 4). The PAII control bit allows configuring the pulse accumulator input edge detect for polled or interrupt-driven operation but does not affect setting or clearing the PAIF bit. When PAII is zero, pulse accumulator input interrupts are inhibited, and the system operates in a polled mode. In this mode, the PAIF bit must be polled by user software to determine when an edge has occurred. When the PAII control bit is set, a hardware interrupt request is generated each time PAIF is set. Before leaving the interrupt service routine, software must clear PAIF by writing to the TFLG2 register.

**TMSK2 — Timer Interrupt Mask 2**

**\$0024**

	Bit 7	6	5	4	3	2	1	Bit 0
	TOI	RTII	PAOVI	PAII	0	0	PR1	PR0
RESET:	0	0	0	0	0	0	0	0

**TFLG2 — Timer Interrupt Flag 2**

**\$0025**

	Bit 7	6	5	4	3	2	1	Bit 0
	TOF	RTIF	PAOVF	PAIF	0	0	0	0
RESET:	0	0	0	0	0	0	0	0

## APPENDIX A ELECTRICAL CHARACTERISTICS

### Table A-1 Maximum Ratings

Rating	Symbol	Value	Unit
Supply Voltage	$V_{DD}$	- 0.3 to + 7.0	V
Input Voltage	$V_{in}$	- 0.3 to + 7.0	V
Operating Temperature Range MC6811D3 MC6811D3C MC6811D3V MC6811D3M	$T_A$	$T_L$ to $T_H$ 0 to + 70 - 40 to + 85 - 40 to + 105 - 40 to + 125	°C
Storage Temperature Range	$T_{stg}$	- 55 to + 150	°C
Current Drain per Pin* Excluding $V_{DD}$ and $V_{SS}$	$I_D$	25	mA

\*One pin at a time, observing maximum power dissipation limits.

Internal circuitry protects the inputs against damage caused by high static voltages or electric fields; however, normal precautions are necessary to avoid application of any voltage higher than maximum-rated voltages to this high-impedance circuit. Extended operation at the maximum ratings can adversely affect device reliability. Tying unused inputs to an appropriate logic voltage level (either GND or  $V_{DD}$ ) enhances reliability of operation.

### Table A-2 Thermal Characteristics

Characteristic	Symbol	Value	Unit
Average Junction Temperature	$T_J$	$T_A + (P_D \times \Theta_{JA})$	°C
Ambient Temperature	$T_A$	User-determined	°C
Package Thermal Resistance (Junction-to-Ambient) 44-Pin Plastic Leaded Chip Carrier (PLCC) 44-Pin Plastic Quad Flat Pack (QFP) 52-Pin Plastic Dip (P)	$\Theta_{JA}$	50 50 50	°C/W
Total Power Dissipation (Note 1)	$P_D$	$\frac{P_{INT} + P_{I/O}}{K / (T_J + 273^\circ\text{C})}$	W
Device Internal Power Dissipation	$P_{INT}$	$I_{DD} \times V_{DD}$	W
I/O Pin Power Dissipation (Note 2)	$P_{I/O}$	User-determined	W
A Constant (Note 3)	K	$P_D \times (T_A + 273^\circ\text{C}) + \Theta_{JA} \times P_D^2$	W < °C

**NOTES:**

1. This is an approximate value, neglecting  $P_{I/O}$ .
2. For most applications  $P_{I/O} \ll P_{INT}$  and can be neglected.
3. K is a constant pertaining to the device. Solve for K with a known  $T_A$  and a measured  $P_D$  (at equilibrium). Use this value of K to solve for  $P_D$  and  $T_J$  iteratively for any value of  $T_A$ .

### ELECTRICAL CHARACTERISTICS

**Table A-3 DC Electrical Characteristics**

Characteristic	Symbol	Min	Max	Unit
Output Voltage (Note 1) All Outputs except XTAL All Outputs Except XTAL, $\overline{\text{RESET}}$ , and MODA $I_{\text{LOAD}} = \pm 10.0 \mu\text{A}$	$V_{\text{OL}}$ $V_{\text{OH}}$	— $V_{\text{DD}} - 0.1$	0.1 —	V V
Output High Voltage (Note 1) All Outputs Except XTAL, $\overline{\text{RESET}}$ , and MODA $I_{\text{LOAD}} = -0.8 \text{ mA}$ , $V_{\text{DD}} = 4.5 \text{ V}$	$V_{\text{OH}}$	$V_{\text{DD}} - 0.8$	—	V
Output Low Voltage All Outputs Except XTAL $I_{\text{LOAD}} = 1.6 \text{ mA}$ , $V_{\text{DD}} = 5.0 \text{ V}$	$V_{\text{OL}}$	—	0.4	V
Input High Voltage All Inputs Except $\overline{\text{RESET}}$ $\overline{\text{RESET}}$	$V_{\text{IH}}$	$0.7 \times V_{\text{DD}}$ $0.8 \times V_{\text{DD}}$	$V_{\text{DD}} + 0.3$ $V_{\text{DD}} + 0.3$	V V
Input Low Voltage All Inputs	$V_{\text{IL}}$	$V_{\text{SS}} - 0.3$	$0.2 \times V_{\text{DD}}$	V
I/O Ports, Three-State Leakage PA7, PA3, PB[7:0], PC[7:0], PD[7:0], $V_{\text{in}} = V_{\text{IH}}$ or $V_{\text{IL}}$ MODA/LIR, $\overline{\text{RESET}}$	$I_{\text{OZ}}$	—	$\pm 10$	$\mu\text{A}$
Input Leakage Current $V_{\text{in}} = V_{\text{DD}}$ or $V_{\text{SS}}$ $V_{\text{in}} = V_{\text{DD}}$ or $V_{\text{SS}}$ PA[2:0], $\overline{\text{IRQ}}$ , $\overline{\text{XIRQ}}$ MODB/ $V_{\text{STBY}}$	$I_{\text{in}}$	— —	$\pm 1$ $\pm 10$	$\mu\text{A}$ $\mu\text{A}$
RAM Standby Voltage Power down	$V_{\text{SB}}$	4.0	$V_{\text{DD}}$	V
RAM Standby Current Power down	$I_{\text{SB}}$	—	10	$\mu\text{A}$
Input Capacitance PA[2:0], $\overline{\text{IRQ}}$ , $\overline{\text{XIRQ}}$ , EXTAL PA7, PA3, PB[7:0], PC[7:0], PD[7:0], MODA/LIR, $\overline{\text{RESET}}$	$C_{\text{in}}$	— —	8 12	pF pF
Output Load Capacitance All Outputs Except PD[4:1] PD[4:1]	$C_{\text{L}}$	— —	90 100	pF pF

Characteristic	Symbol	1 MHz	2 MHz	Unit
Maximum Total Supply Current (Note 2) <b>RUN:</b> Single-Chip Mode Expanded Multiplexed Mode $V_{\text{DD}} = 5.5 \text{ V}$ $V_{\text{DD}} = 5.5 \text{ V}$ <b>WAIT:</b> (All Peripheral Functions Shut Down) Single-Chip Mode Expanded Multiplexed Mode $V_{\text{DD}} = 5.5 \text{ V}$ $V_{\text{DD}} = 5.5 \text{ V}$ <b>STOP:</b> Single-Chip Mode, No Clocks $V_{\text{DD}} = 5.5 \text{ V}$	$I_{\text{DD}}$   $W_{\text{IDD}}$   $S_{\text{IDD}}$	8 14 3 5 50	15 27 6 10 50	mA mA mA mA $\mu\text{A}$
Maximum Power Dissipation Single-Chip Mode Expanded Multiplexed Mode $V_{\text{DD}} = 5.5 \text{ V}$ $V_{\text{DD}} = 5.5 \text{ V}$	$P_{\text{D}}$	44 77	85 150	mW mW

**NOTES:**

- $V_{\text{OH}}$  specification for  $\overline{\text{RESET}}$  and MODA is not applicable because they are open-drain pins.  $V_{\text{OH}}$  specification not applicable to ports C and D in wired-OR mode.
- EXTAL is driven with a square wave, and  
 $t_{\text{cyc}} = 1000 \text{ ns}$  for 1 MHz rating;  
 $t_{\text{cyc}} = 500 \text{ ns}$  for 2 MHz rating;  
 $t_{\text{cyc}} = 333 \text{ ns}$  for 3 MHz rating;  
 $V_{\text{IL}} \leq 0.2 \text{ V}; V_{\text{IH}} \geq V_{\text{DD}} - 0.2 \text{ V};$   
 No dc loads.

**ELECTRICAL CHARACTERISTICS**

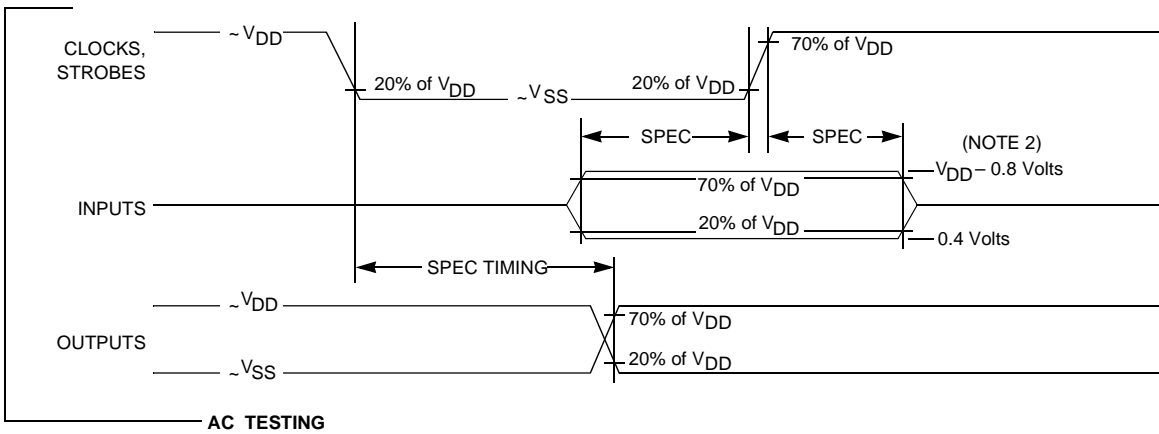
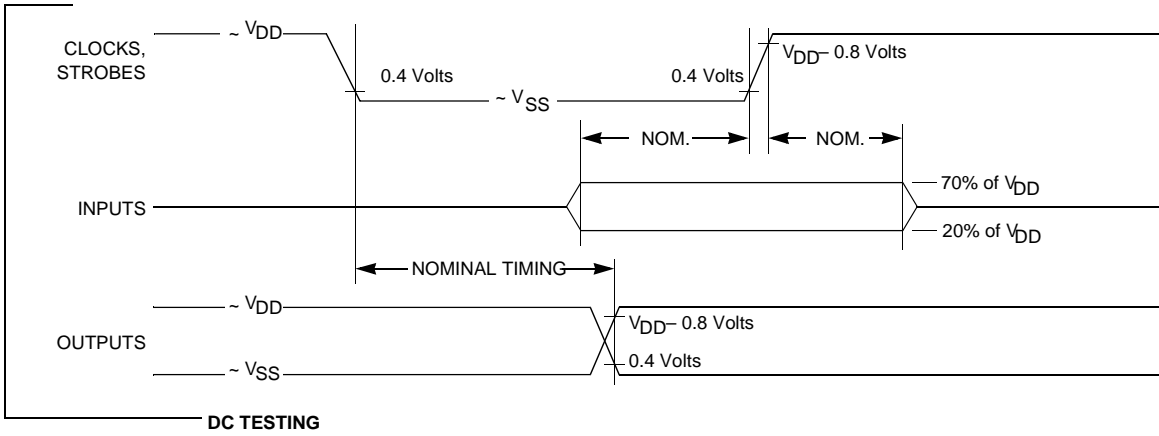

NOTES:

1. Full test loads are applied during all DC electrical tests and AC timing measurements.
2. During AC timing measurements, inputs are driven to 0.4 volts and  $V_{DD} - 0.8$  volts while timing measurements are taken at the 20% and 70% of  $V_{DD}$  points.

TEST METHODS

Figure A-1 Test Methods

Table A-4 Control Timing

Characteristic	Symbol	1.0 MHz		2.0 MHz		3.0 MHz		Unit
		Min	Max	Min	Max	Min	Max	
Frequency of Operation	$f_o$	dc	1.0	dc	2.0	dc	3.0	MHz
E-Clock Period	$t_{cyc}$	1000	—	500	—	333	—	ns
Crystal Frequency	$f_{XTAL}$	—	4.0	—	8.0	—	12.0	MHz
External Oscillator Frequency	$4 f_o$	dc	4.0	dc	8.0	dc	12.0	MHz
Processor Control SetupTime $t_{PCSU} = 1/4 t_{cyc} + 50 \text{ ns}$	$t_{PCSU}$	300	—	175	—	133	—	ns
Reset Input Pulse Width To Guarantee External Reset Vector Minimum Input Time (Can Be Preempted by Internal Reset)	$PW_{RSTL}$	8 1	— —	8 1	— —	8 1	— —	$t_{cyc}$ $t_{cyc}$
Mode Programming Setup Time	$t_{MPS}$	2	—	2	—	2	—	$t_{cyc}$
Mode Programming Hold Time	$t_{MPH}$	10	—	10	—	10	—	ns
Interrupt Pulse Width, IRQ Edge-Sensitive Mode $PW_{IRQ} = t_{cyc} + 20 \text{ ns}$	$PW_{IRQ}$	1020	—	520	—	353	—	ns
Wait Recovery Startup Time	$t_{WRS}$	—	4	—	4	—	4	$t_{cyc}$
Timer Pulse Width, Input Capture Pulse Accumulator Input $PW_{TIM} = t_{cyc} + 20 \text{ ns}$	$PW_{TIM}$	1020	—	520	—	353	—	ns

NOTES:

1. RESET is recognized during the first clock cycle it is held low. Internal circuitry then drives the pin low for four clock cycles, releases the pin, and samples the pin level two cycles later to determine the source of the interrupt. Refer to **SECTION 5 RESETS AND INTERRUPTS** for further detail.
2. All timing is shown with respect to 20%  $V_{DD}$  and 70%  $V_{DD}$ , unless otherwise noted.

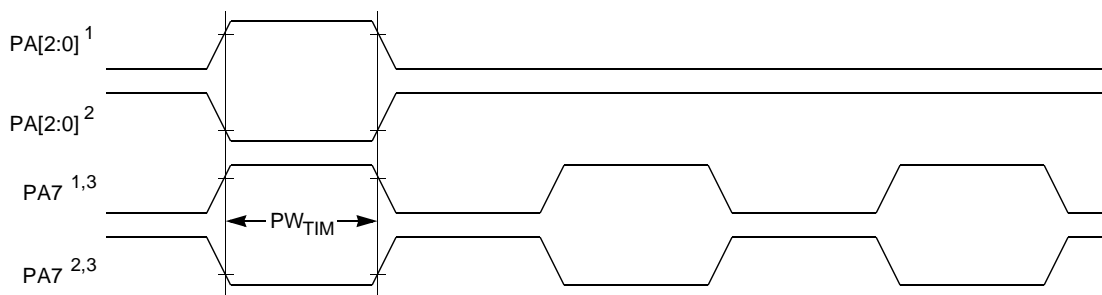

NOTES:

1. Rising edge sensitive input
2. Falling edge sensitive input
3. Maximum pulse accumulator clocking rate is E-clock frequency divided by 2.

TIMER INPUTS TIM

Figure A-2 Timer Inputs

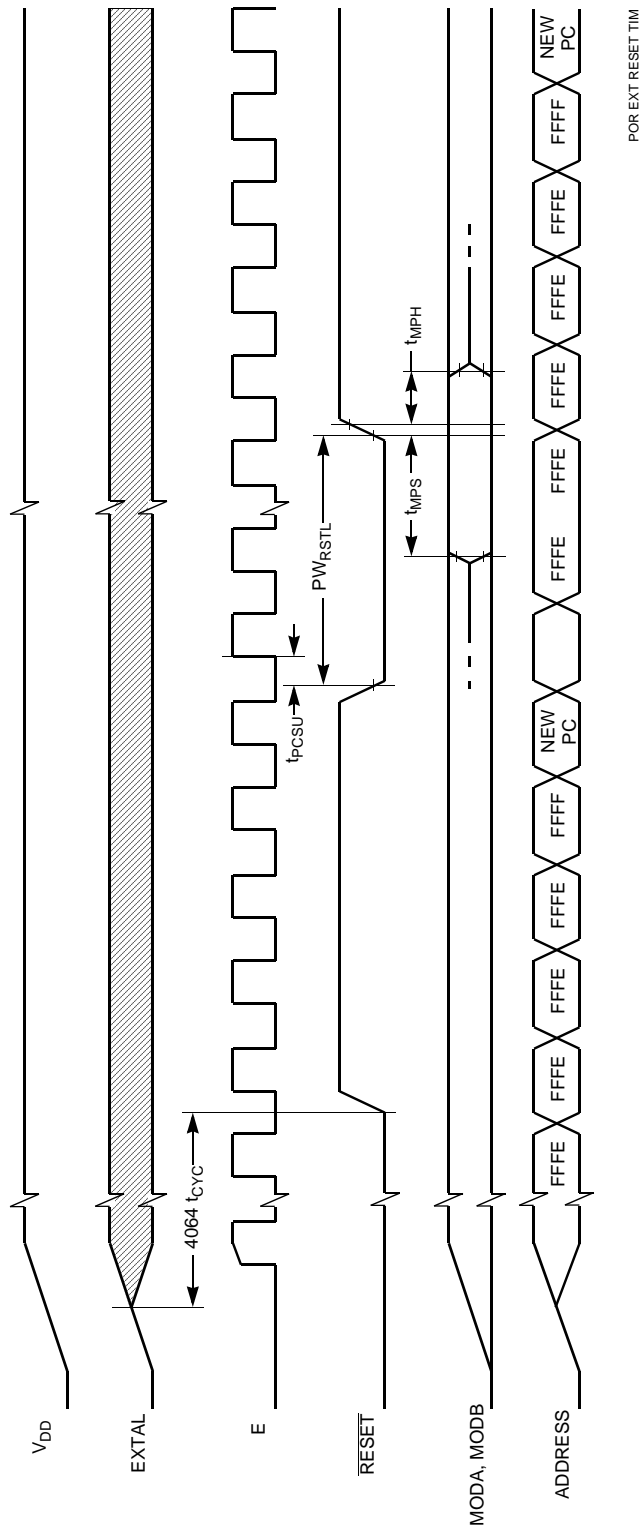
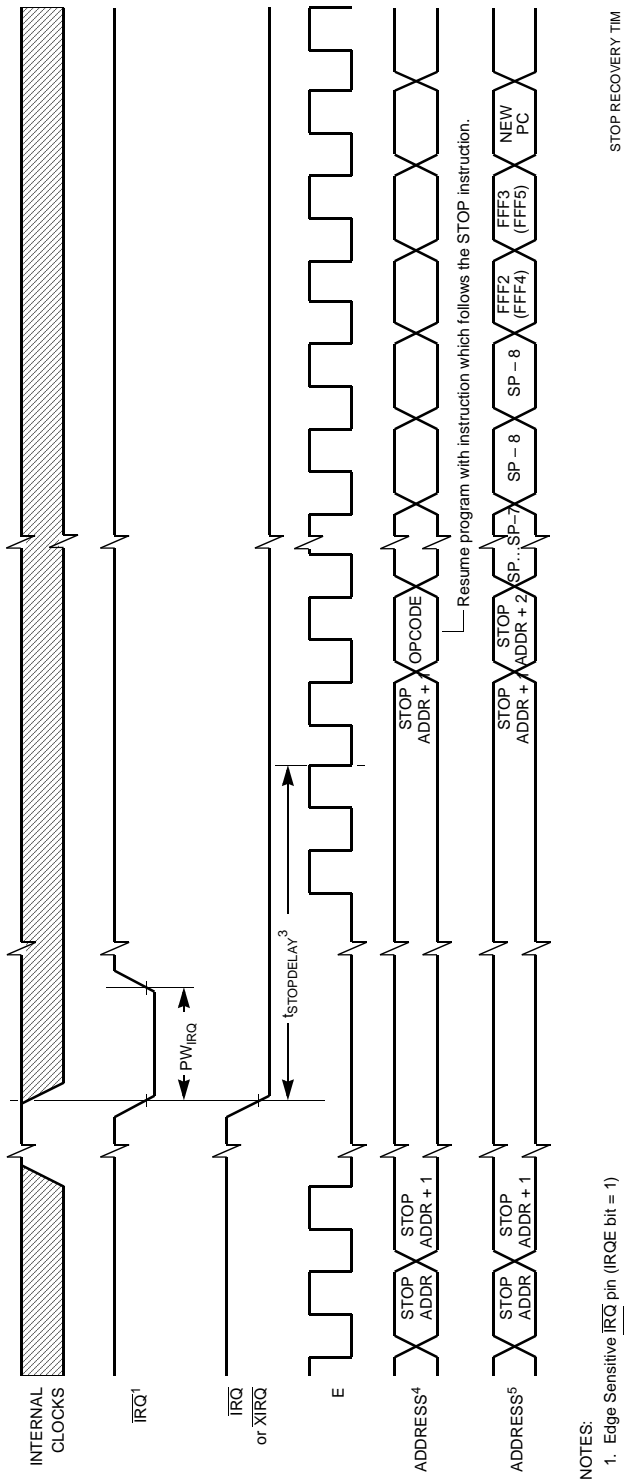

Figure A-3 POR and External Reset Timing Diagram

ELECTRICAL CHARACTERISTICS



- NOTES:
1. Edge Sensitive  $\overline{IRQ}$  pin (IROE bit = 1)
  2. Level sensitive  $\overline{IRQ}$  pin (IROE bit = 0)
  3.  $t_{STOPDELAY} = 4064 t_{CYC}$  if DLY bit = 1 or  $4 t_{CYC}$  if DLY = 0.
  4.  $\overline{XIRQ}$  with X bit in CCR = 1.
  5.  $\overline{IRQ}$  or  $\overline{XIRQ}$  with X bit in CCR = 0).

Figure A-4 STOP Recovery Timing Diagram

ELECTRICAL CHARACTERISTICS

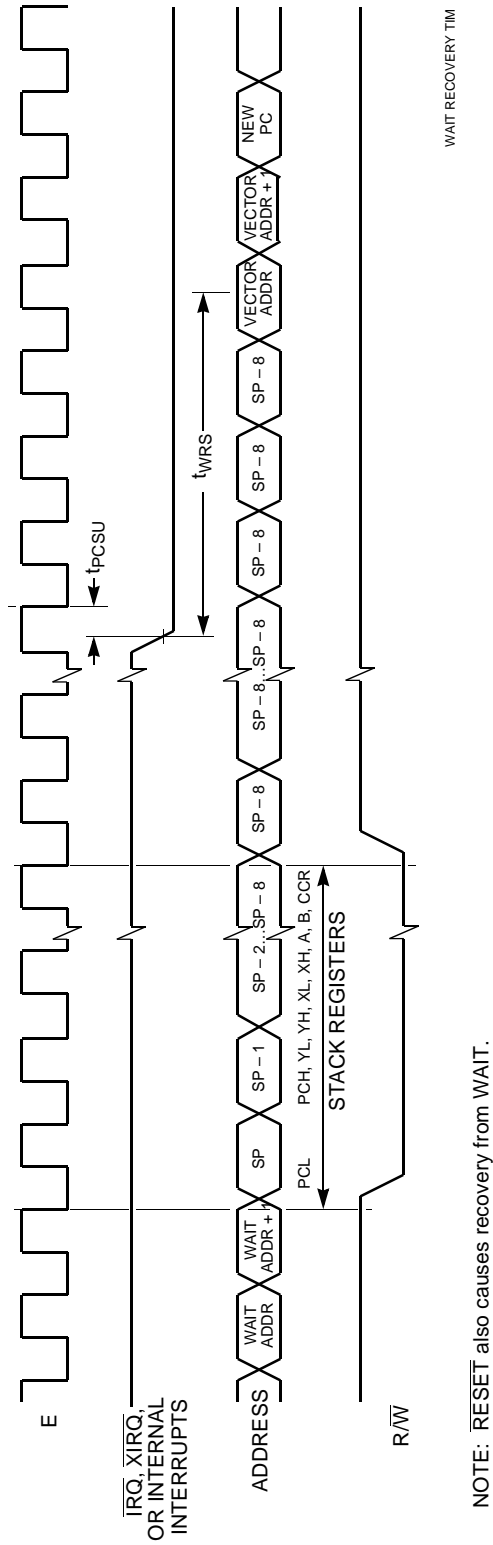

NOTE: RESET also causes recovery from WAIT.

Figure A-5 WAIT Recovery Timing Diagram

ELECTRICAL CHARACTERISTICS

**Table A-5 Peripheral Port Timing**

Characteristic	Symbol	1.0 MHz		2.0 MHz		3.0 MHz		Unit
		Min	Max	Min	Max	Min	Max	
Frequency of Operation (E-Clock Frequency)	$f_o$	dc	1.0	dc	2.0	dc	3.0	MHz
E-Clock Period	$t_{cyc}$	1000	—	500	—	333	—	ns
Peripheral Data Setup Time MCU Read of Ports A, B, C, and D	$t_{PDSU}$	100	—	100	—	100	—	ns
Peripheral Data Hold Time MCU Read of Ports A, B, C, and D	$t_{PDH}$	50	—	50	—	50	—	ns
Delay Time, Peripheral Data Write  MCU Write to Port A MCU Writes to Ports B, C, and D $t_{PWD} = 1/4 t_{cyc} + 150 \text{ ns}$	$t_{PWD}$	—	200 350	—	200 225	—	200 183	ns ns

**NOTES:**

1. Port C and D timing is valid for active drive (CWOM and DWOM bits not set in PIOC and SPCR registers respectively).
2. All timing is shown with respect to 20%  $V_{DD}$  and 70%  $V_{DD}$ , unless otherwise noted.

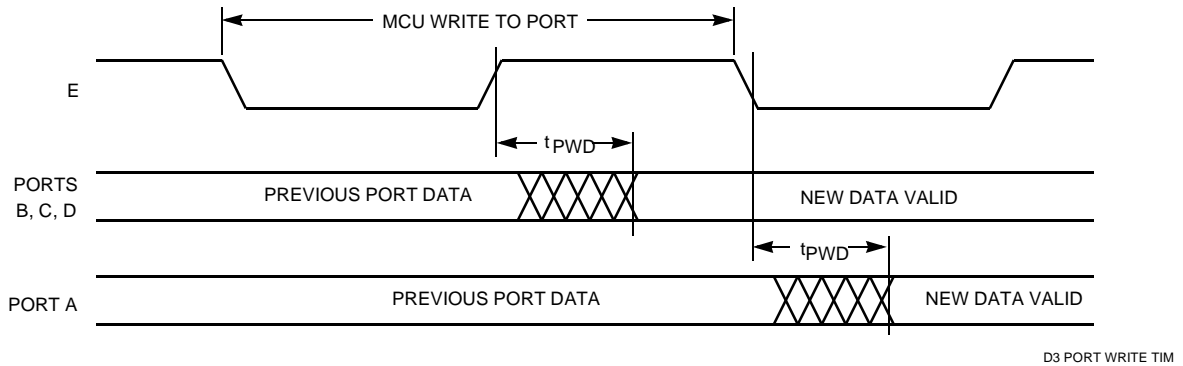

**Figure A-6 Port Write Timing Diagram**

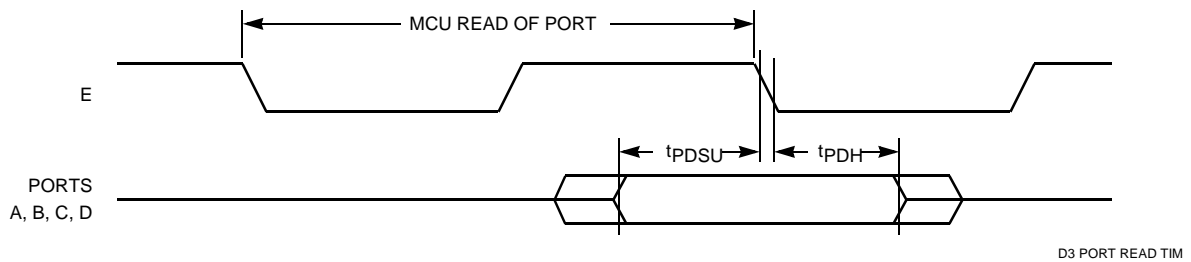

**Figure A-7 Port Read Timing Diagram**

**Table A-6 Expansion Bus Timing**

Num	Characteristic	Symbol	1.0 MHz		2.0 MHz		3.0 MHz		Unit
			Min	Max	Min	Max	Min	Max	
	Frequency of Operation (E-Clock Frequency)	$f_o$	dc	1.0	dc	2.0	dc	3.0	MHz
1	Cycle Time	$t_{cyc}$	1000	—	500	—	333	—	ns
2	Pulse Width, E Low $PW_{EL} = 1/2 t_{cyc} - 23ns$	$PW_{EL}$	477	—	227	—	146	—	ns
3	Pulse Width, E High $PW_{EH} = 1/2 t_{cyc} - 28 ns$	$PW_{EH}$	472	—	222	—	141	—	ns
4A	E and AS Rise Time	$t_r$	—	20	—	20	—	20	ns
4B	E and AS Fall Time	$t_f$	—	20	—	20	—	15	ns
9	Address Hold Time $t_{AH} = 1/8 t_{cyc} - 29.5 ns$ (Note 1a)	$t_{AH}$	95.5	—	33	—	26	—	ns
12	Non-Muxed Address Valid Time to E Rise $t_{AV} = PW_{EL} - (t_{ASD} + 80 ns)$ (Note 1a)	$t_{AV}$	281.5	—	94	—	54	—	ns
17	Read Data Setup Time	$t_{DSR}$	30	—	30	—	30	—	ns
18	Read Data Hold Time (Max = $t_{MAD}$ )	$t_{DHR}$	0	145.5	0	83	0	51	ns
19	Write Data Delay Time $t_{DDW} = 1/8 t_{cyc} + 65.5 ns$ (Note 1a)	$t_{DDW}$	—	190.5	—	128	—	71	ns
21	Write Data Hold Time $t_{DHW} = 1/8 t_{cyc} - 30 ns$ (Note 1a)	$t_{DHW}$	95.5	—	33	—	26	—	ns
22	Muxed Address Valid Time to E Rise $t_{AVM} = PW_{EL} - (t_{ASD} + 90 ns)$ (Note 1a)	$t_{AVM}$	271.5	—	84	—	54	—	ns
24	Muxed Address Valid Time to AS Fall $t_{ASL} = PW_{ASH} - 70 ns$	$t_{ASL}$	151	—	26	—	13	—	ns
25	Muxed Address Hold Time $t_{AHL} = 1/8 t_{cyc} - 30 ns$ (Note 1b)	$t_{AHL}$	95.5	—	33	—	31	—	ns
26	Delay Time, E to AS Rise $t_{ASD} = 1/8 t_{cyc} - 5 ns$ (Note 1a)	$t_{ASD}$	115.5	—	53	—	31	—	ns
27	Pulse Width, AS High $PW_{ASH} = 1/4 t_{cyc} - 30 ns$	$PW_{ASH}$	221	—	96	—	63	—	ns
28	Delay Time, AS to E Rise $t_{ASED} = 1/8 t_{cyc} - 5 ns$ (Note 1b)	$t_{ASED}$	115.5	—	53	—	31	—	ns
29	MPU Address Access Time (Note 1a) $t_{ACCA} = t_{cyc} - (PW_{EL} - t_{AVM}) - t_{DSR} - t_f$	$t_{ACCA}$	744.5	—	307	—	196	—	ns
35	MPU Access Time $t_{ACCE} = PW_{EH} - t_{DSR}$	$t_{ACCE}$	—	442	—	192	—	111	ns
36	Muxed Address Delay (Previous Cycle MPU Read) $t_{MAD} = t_{ASD} + 30 ns$ (Note 1a)	$t_{MAD}$	145.5	—	83	—	51	—	ns

**NOTES:**

1. Input clocks with duty cycles other than 50% affect bus performance. Timing parameters affected by input clock duty cycle are identified by (a) and (b). To recalculate the approximate bus timing values, substitute the following expressions in place of  $1/8 t_{cyc}$  in the above formulas, where applicable:

(a)  $(1-DC) \times 1/4 t_{cyc}$

(b)  $DC \times 1/4 t_{cyc}$

Where:

DC is the decimal value of duty cycle percentage (high time).

2. All timing is shown with respect to 20%  $V_{DD}$  and 70%  $V_{DD}$ , unless otherwise noted.

**ELECTRICAL CHARACTERISTICS**

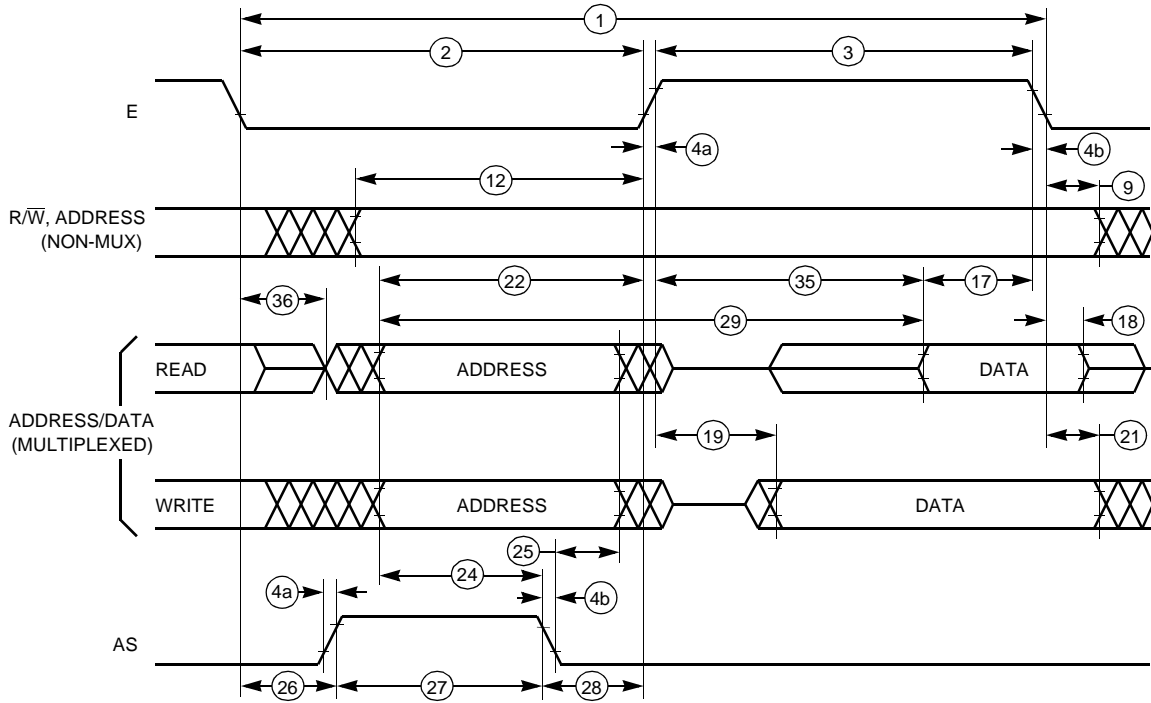

NOTE: Measurement points shown are 20% and 70% of  $V_{DD}$ .

MUX BUS TIM

Figure A-8 Multiplexed Expansion Bus Timing Diagram

Freescale Semiconductor, Inc.

**Table A-7 Serial Peripheral Interface Timing**

Num	Characteristic	Symbol	2.0 MHz		3.0 MHz		Unit
			Min	Max	Min	Max	
	Operating Frequency Master Slave	$f_{op(m)}$ $f_{op(s)}$	dc dc	0.5 2.0	dc dc	0.5 3.0	$f_{op}$ MHz
1	Cycle Time Master Slave	$t_{cyc(m)}$ $t_{cyc(s)}$	2.0 500	— —	2.0 333	— —	$t_{cyc}$ ns
2	Enable Lead Time Master (Note 2) Slave	$t_{lead(m)}$ $t_{lead(s)}$	— 250	— —	— 240	— —	ns ns
3	Enable Lag Time Master (Note 2) Slave	$t_{lag(m)}$ $t_{lag(s)}$	— 250	— —	— 240	— —	ns ns
4	Clock (SCK) High Time Master Slave	$t_{w(SCKH)m}$ $t_{w(SCKH)s}$	340 190	— —	340 190	— —	ns ns
5	Clock (SCK) Low Time Master Slave	$t_{w(SCKL)m}$ $t_{w(SCKL)s}$	340 190	— —	340 190	— —	ns ns
6	Data Setup Time (Inputs) Master Slave	$t_{su(m)}$ $t_{su(s)}$	100 100	— —	100 100	— —	ns ns
7	Data Hold Time (Inputs) Master Slave	$t_h(m)$ $t_h(s)$	100 100	— —	100 100	— —	ns ns
8	Access Time (Time to Data Active from High-Imp. State) Slave	$t_a$	0	120	0	120	ns
9	Disable Time (Hold Time to High-Impedance State) Slave	$t_{dis}$	—	240	—	167	ns
10	Data Valid (After Enable Edge) (Note 3)	$t_{v(s)}$	—	240	—	167	ns
11	Data Hold Time (Outputs) (After Enable Edge)	$t_{ho}$	0	—	0	—	ns
12	Rise Time (20% $V_{DD}$ to 70% $V_{DD}$ , $C_L = 200$ pF) SPI Outputs (SCK, MOSI, and MISO) SPI Inputs (SCK, MOSI, MISO, and $\overline{SS}$ )	$t_{rm}$ $t_{rs}$	— —	100 2.0	— —	100 2.0	ns $\mu$ s
13	Fall Time (70% $V_{DD}$ to 20% $V_{DD}$ , $C_L = 200$ pF) SPI Outputs (SCK, MOSI, and MISO) SPI Inputs (SCK, MOSI, MISO, and $\overline{SS}$ )	$t_{fm}$ $t_{fs}$	— —	100 2.0	— —	100 2.0	ns $\mu$ s

**NOTES:**

1. All timing is shown with respect to 20%  $V_{DD}$  and 70%  $V_{DD}$ , unless otherwise noted.
2. Signal production depends on software.
3. Assumes 100 pF load on all SPI pins.

**ELECTRICAL CHARACTERISTICS**

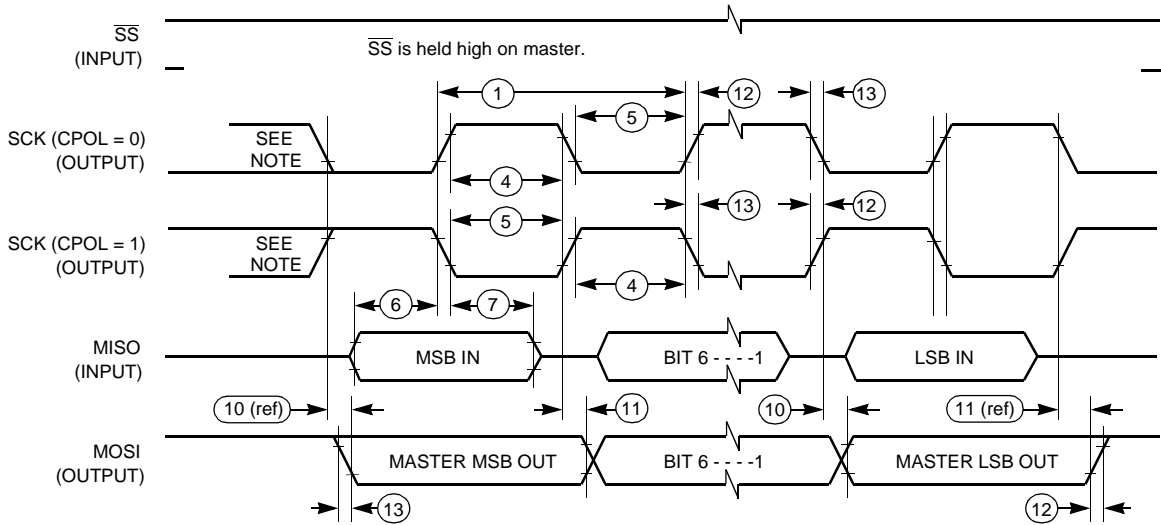

NOTE: This first clock edge is generated internally but is not seen at the SCK pin.

SPI MASTER CPHA0 TIM

Figure A-9 SPI Master Timing (CPHA = 0)

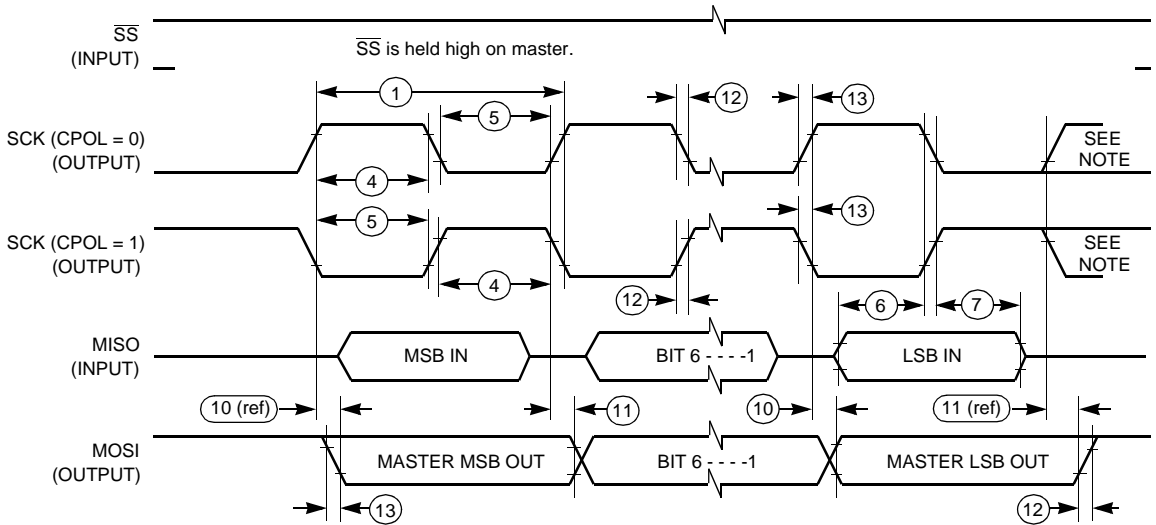

NOTE: This last clock edge is generated internally but is not seen at the SCK pin.

SPI MASTER CPHA1 TIM

Figure A-10 SPI Master Timing (CPHA = 1)

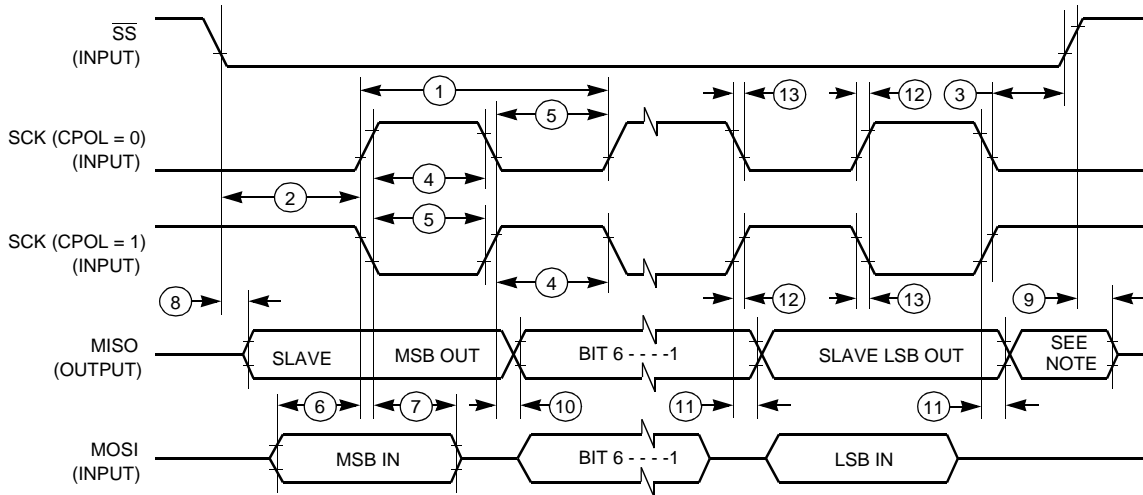

NOTE: Not defined but normally MSB of character just received.

SPI SLAVE CPHA0 TIM

Figure A-11 SPI Slave Timing (CPHA = 0)

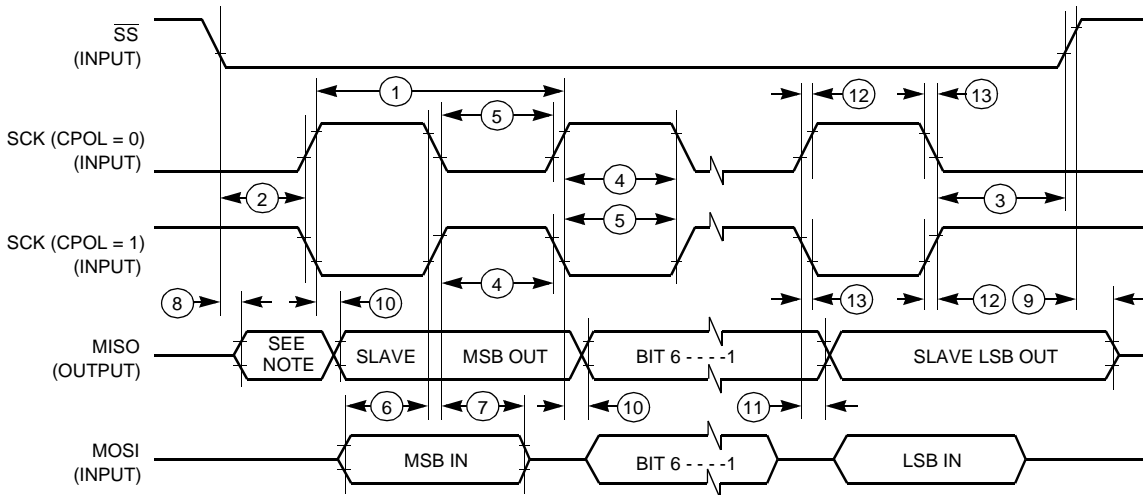

NOTE: Not defined but normally LSB of character previously transmitted.

SPI SLAVE CPHA1 TIM

Figure A-12 SPI Slave Timing (CPHA = 1)

Freescale Semiconductor, Inc.



**ELECTRICAL CHARACTERISTICS**

**APPENDIX B  
MECHANICAL DATA AND ORDERING INFORMATION**

**B.1 Pin Assignments**

The MC68HC11D3 is available in the 40-pin DIP, shown in **Figure B-1**, the 44-pin PLCC, shown in **Figure B-2**, or the 44-pin quad flat pack (QFP), as shown in **Figure B-3**. Refer to **Table B-1** for ordering information.

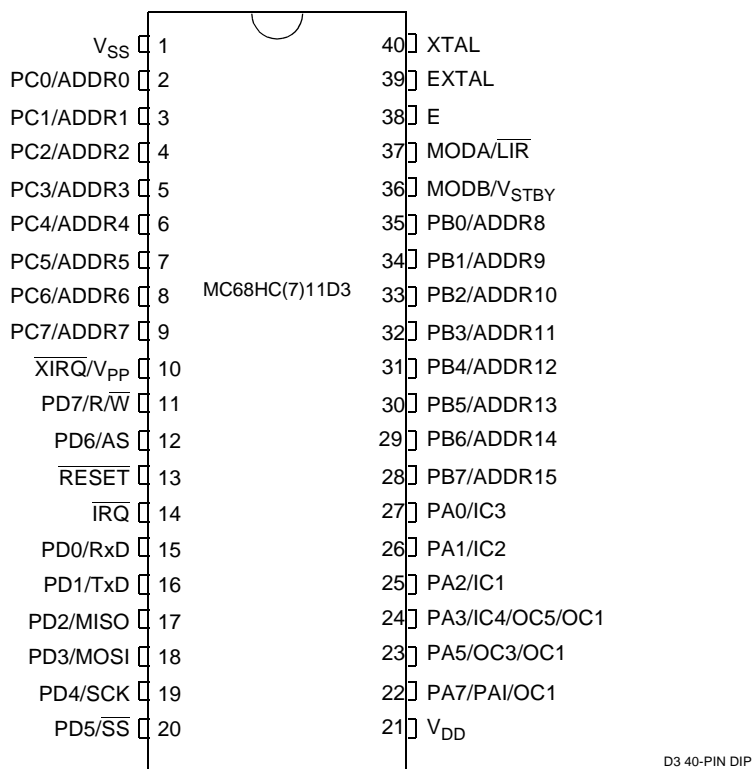

**Figure B-1 40-Pin DIP**

Freescale Semiconductor, Inc.

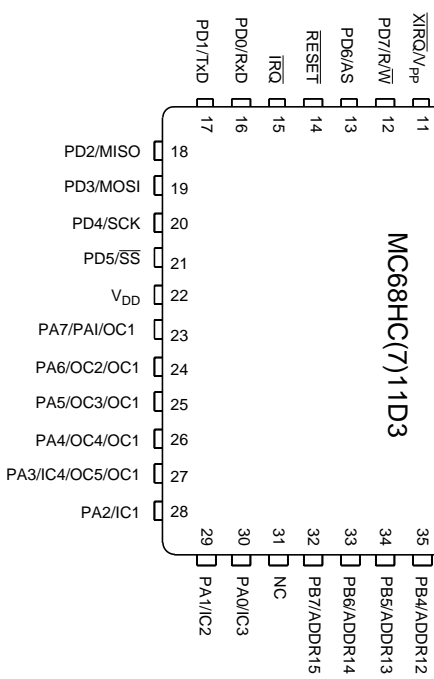
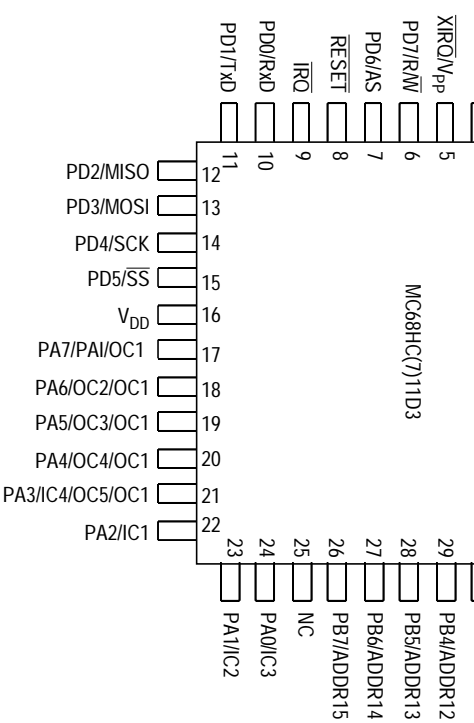

Figure B-2 44-Pin PLCC

**Freescale Semiconductor, inc.**





**Figure B-3 44-Pin QFP**

## B.2 Package Dimensions

For case outline information check our web site at <http://www.motspcs.com>.

## B.3 Ordering Information

Add the proper suffix, from **Table B-1**, to the M68HC11- (or 711-) MCU number to specify the appropriate device when placing an order. **Figure B-4** identifies the codes used to identify specific MCU options.

**Table B-1 Ordering Information**

MCU	Package	Temperature	Description	Suffix
D3	40-Pin DIP	-40 to +85°C	BUFFALO ROM	CP1
	44-Pin PLCC	-40 to +85°C	BUFFALO ROM	CFN1
	44-Pin Quad Flat Pack	-40 to +85°C	BUFFALO ROM	CFBL
D0	40-Pin DIP	-40 to +85°C	No ROM	CP
	44-Pin PLCC	-40 to +85°C	No ROM	CFN
	44-Pin Quad Flat Pack	-40 to +85°C	No ROM	CFB

**Freemicrocontroller, Freescale Semiconductor**



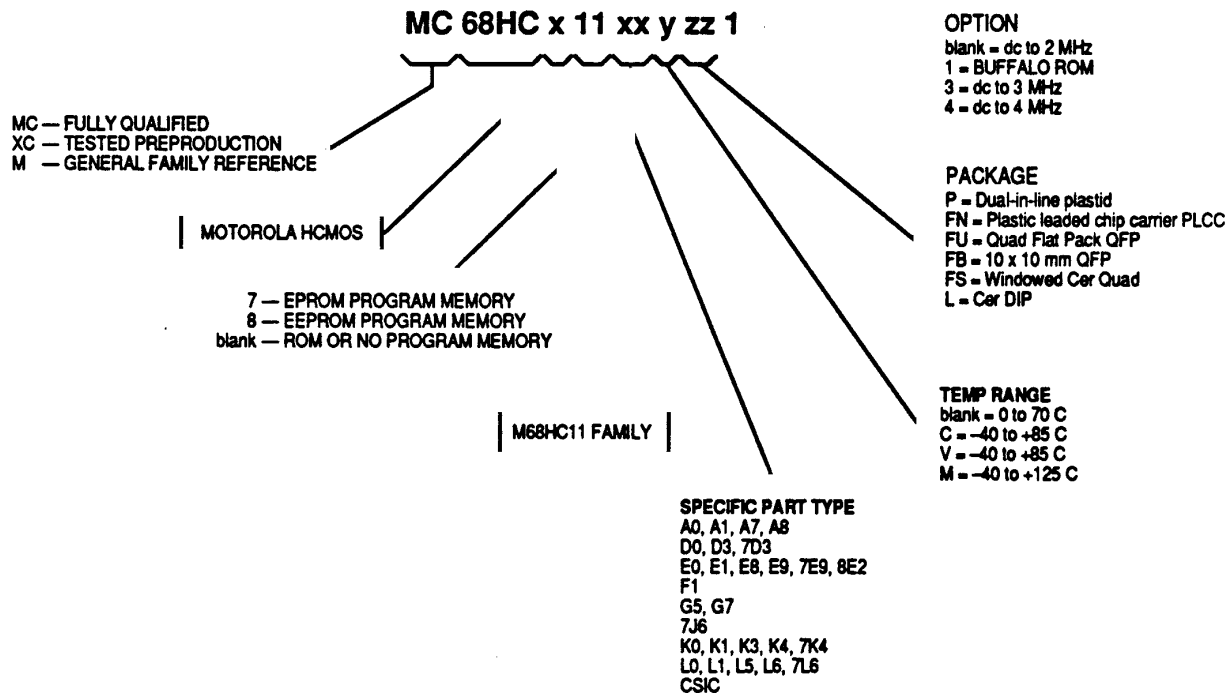

Figure B-4 M68HC11 Part Number Options

Freescale Semiconductor, Inc.

## **APPENDIX C DEVELOPMENT SUPPORT**

### **C.1 Development System Tools**

Freescale has developed tools for use in debugging and evaluating M68HC11 equipment. Refer to the following list for those development tools that are available for use with the MC68HC11D3. For information about Freescale and third party development system hardware and software, contact your Freescale sales representative.

### **C.2 MC68HC11D3 Development Tools**

- M68HC11D3EVS Evaluation System
- M68HC711D3PGMR Programmer Board
- M68HC711D3EVB Evaluation Board



## Looking for pricing, stock, or lifecycle information?

Click below to explore more details on WIN SOURCE:

- ⊖ [View MC68HC711D3CFNE3 on WIN SOURCE](#)
- ⊖ [Freescale Semiconductor - NXP Information](#)

## Optimize Your Supply Chain with WIN SOURCE Solutions

- ✓ Global Sourcing Solution
- ✓ Obsolete Management
- ✓ Cost Control Management
- ✓ Shortage Management
- ✓ Alternative Solution
- ✓ Excess Inventory Management