



**THE DATASHEET OF
MC56F84441VLF**



MC56F844XX

MC56F844XX

Supports the 56F84462VLH,
56F84452VLH, 56F84451VLF,
56F84442VLH, 56F84441VLF

Features

- This family of digital signal controllers (DSCs) is based on the 32-bit 56800EX core. Each device combines, on a single chip, the processing power of a DSP and the functionality of an MCU with a flexible set of peripherals to support many target applications:
 - Industrial control
 - Home appliances
 - Smart sensors
 - Fire and security systems
 - Switched-mode power supply and power management
 - Uninterruptible Power Supply (UPS)
 - Solar and wind power generator
 - Power metering
 - Motor control (ACIM, BLDC, PMSM, SR, stepper)
 - Handheld power tools
 - Circuit breaker
 - Medical device/equipment
 - Instrumentation
 - Lighting
- DSC based on 32-bit 56800EX core
 - Up to 60 MIPS at 60 MHz core frequency
 - DSP and MCU functionality in a unified, C-efficient architecture
- On-chip memory
 - Up to 160 KB (128 KB + 32 KB) flash memory, including up to 32 KB FlexNVM
 - Up to 24 KB RAM
 - Up to 2 KB FlexRAM with EEE capability
 - 60 MHz program execution from both internal flash memory and RAM
 - On-chip flash memory and RAM can be mapped into both program and data memory spaces
- Analog
 - Two high-speed, 8-channel, 12-bit ADCs with dynamic x2, x4 programmable amplifier
 - One 20-channel, 16-bit ADC
 - Up to four analog comparators with integrated 6-bit DAC references
 - One 12-bit DAC
- PWMs and timers
 - One eFlexPWM module with up to 9 PWM outputs
 - Two 16-bit quad timer (2 x 4 16-bit timers)
 - Two Periodic Interval Timers (PITs)
 - One Quadrature Decoder
 - Two Programmable Delay Blocks (PDBs)
- Communication interfaces
 - Two high-speed queued SCI (QSCI) modules with LIN slave functionality
 - One queued SPI (QSPI) module
 - Two SMBus-compatible I2C ports
 - One flexible controller area network (FlexCAN) module
- Security and integrity
 - Cyclic Redundancy Check (CRC) generator
 - Computer operating properly (COP) watchdog
 - External Watchdog Monitor (EWM)
- Clocks
 - Two on-chip relaxation oscillators: 8 MHz (400 kHz at standby mode) and 32 kHz
 - Crystal / resonator oscillator
- System
 - DMA controller
 - Integrated power-on reset (POR) and low-voltage interrupt (LVI) and brown-out reset module
 - Inter-module crossbar connection
 - JTAG/enhanced on-chip emulation (EOnCE) for unobtrusive, real-time debugging

Freescale reserves the right to change the detail specifications as may be required to permit improvements in the design of its products.

- Operating characteristics
 - Single supply: 3.0 V to 3.6 V
 - 5 V-tolerant I/O (except RESETB pin)
- LQFP packages:
 - 48-pin
 - 64-pin

Table of Contents

1	Overview.....	4	7	Ratings.....	33
1.1	MC56F844xx/5xx/7xx product family.....	4	7.1	Thermal handling ratings.....	33
1.2	56800EX 32-bit Digital Signal Controller (DSC) core.....	5	7.2	Moisture handling ratings.....	33
1.3	Operation parameters.....	6	7.3	ESD handling ratings.....	33
1.4	On-chip memory and memory protection.....	6	7.4	Voltage and current operating ratings.....	34
1.5	Interrupt Controller.....	7	8	General.....	35
1.6	Peripheral highlights.....	7	8.1	General characteristics.....	35
1.7	Block diagrams.....	13	8.2	AC electrical characteristics.....	35
2	MC56F844xx signal and pin descriptions.....	16	8.3	Nonswitching electrical specifications.....	36
3	Signal groups.....	26	8.4	Switching specifications.....	42
4	Ordering parts.....	27	8.5	Thermal specifications.....	43
4.1	Determining valid orderable parts.....	27	9	Peripheral operating requirements and behaviors.....	44
5	Part identification.....	27	9.1	Core modules.....	44
5.1	Description.....	27	9.2	System modules.....	46
5.2	Format.....	27	9.3	Clock modules.....	46
5.3	Fields.....	28	9.4	Memories and memory interfaces.....	49
5.4	Example.....	28	9.5	Analog.....	52
6	Terminology and guidelines.....	28	9.6	PWMs and timers.....	61
6.1	Definition: Operating requirement.....	28	9.7	Communication interfaces.....	62
6.2	Definition: Operating behavior.....	29	10	Design Considerations.....	68
6.3	Definition: Attribute.....	29	10.1	Thermal design considerations.....	68
6.4	Definition: Rating.....	30	10.2	Electrical design considerations.....	70
6.5	Result of exceeding a rating.....	30	11	Obtaining package dimensions.....	71
6.6	Relationship between ratings and operating requirements.....	30	12	Pinout.....	71
6.7	Guidelines for ratings and operating requirements.....	31	12.1	Signal Multiplexing and Pin Assignments.....	71
6.8	Definition: Typical value.....	31	12.2	Pinout diagrams.....	73
6.9	Typical value conditions.....	32	13	Product documentation.....	76
			14	Revision history.....	76

1 Overview

1.1 MC56F844xx/5xx/7xx product family

The following table lists major features, including features that differ among members of the family. Features not listed are shared by all members of the family.

Table 1. 56F844xx/5xx/7xx family

Part Number	MC56F84																	
	789	786	769	766	763	553	550	543	540	587	585	567	565	462	452	451	442	441
Core freq. (MHz)	100	100	100	100	100	80	80	80	80	80	80	80	80	60	60	60	60	60
Flash memory (KB)	256	256	128	128	128	96	96	64	64	256	256	128	128	128	96	96	64	64
FlevNVM/ FlexRAM (KB)	32/2	32/2	32/2	32/2	32/2	32/2	32/2	32/2	32/2	32/2	32/2	32/2	32/2	32/2	32/2	32/2	32/2	32/2
Total flash memory (KB) ¹	288	288	160	160	160	128	128	96	96	288	288	160	160	160	128	128	96	96
RAM (KB)	32	32	24	24	24	16	16	8	8	32	32	24	24	24	16	16	8	8
Memory resource protection	Yes	Yes	Yes	Yes	Yes	Yes	Yes	Yes	Yes	Yes	Yes	Yes	Yes	Yes	Yes	Yes	Yes	Yes
External Watchdog	1	1	1	1	1	1	1	1	1	1	1	1	1	1	1	1	1	1
12-bit Cyclic ADC Channels (ADCA and ADCB)	2x8	2x8	2x8	2x8	2x8	2x8	2x5	2x8	2x5	2x8	2x8	2x8	2x8	2x8	2x8	2x5	2x8	2x5
12-bit Cyclic ADC Conversion time (ADCA and ADCB)	300 ns	300 ns	300 ns	300 ns	300 ns	300 ns	300 ns	300 ns	300 ns	600 ns	600 ns	600 ns	600 ns	600 ns	600 ns	600 ns	600 ns	600 ns
16-bit SAR ADC (with Temperature Sensor) channels (ADCC)	16	10	16	10	8	8	-	8	-	16	10	16	10	-	8	-	8	-
PWMA High-res channels	8	8	8	8	8	8	6	8	6	0	0	0	0	0	0	0	0	0

Table continues on the next page...

Table 1. 56F844xx/5xx/7xx family (continued)

Part Number	MC56F84																	
	789	786	769	766	763	553	550	543	540	587	585	567	565	462	452	451	442	441
PWMA Std channels	4	1	4	1	1	1	0	1	0	12	12	12	12	9	9	6	9	6
PWMA Input capture channels	12	9	12	9	9	9	6	9	6	12	12	12	12	9	9	6	9	6
PWMB Std channels	12	9 ²	12	9 ²	-	-	-	-	-	12	9 ²	12	9 ²	-	-	-	-	-
PWMB Input capture channels	12	7	12	7	-	-	-	-	-	12	7	12	7	-	-	-	-	-
12-bit DAC	1	1	1	1	1	1	1	1	1	1	1	-	-	1	-	-	-	-
Quad Decoder	1	1	1	1	1	1	1	1	1	1	1	1	1	1	1	1	1	1
DMA	Yes	Yes	Yes	Yes	Yes	Yes	Yes	Yes	Yes	Yes	Yes	Yes	Yes	Yes	Yes	Yes	Yes	Yes
CMP	4	4	4	4	4	4	3	4	3	4	4	4	4	4	4	3	4	3
QSCI	3	3	3	3	2	2	2	2	2	3	3	3	3	2	2	2	2	2
QSPI	3	2	3	2	1	1	1	1	1	3	2	3	2	1	1	1	1	1
I2C/SMBus	2	2	2	2	2	2	2	2	2	2	2	2	2	2	2	2	2	2
FlexCAN	1	1	1	1	1	1	1	1	1	1	1	1	1	1	1	1	0	0
LQFP package pin count	100	80	100	80	64	64	48	64	48	100	80	100	80	64	64	48	64	48

1. This total includes FlexNVM and assumes no FlexNVM is used with FlexRAM for EEPROM.
2. The outputs of PWMB_3A and PWM_3B are available through the on-chip inter-module crossbar.

1.2 56800EX 32-bit Digital Signal Controller (DSC) core

- Efficient 32-bit 56800EX Digital Signal Processor (DSP) engine with modified dual Harvard architecture:
 - Three internal address buses
 - Four internal data buses: two 32-bit primary buses, one 16-bit secondary data bus, and one 16-bit instruction bus
 - 32-bit data accesses
 - Supports concurrent instruction fetches in the same cycle, and dual data accesses in the same cycle
 - 20 addressing modes
- As many as 60 million instructions per second (MIPS) at 60 MHz core frequency
- 162 basic instructions
- Instruction set supports both fractional arithmetic and integer arithmetic

- 32-bit internal primary data buses support 8-bit, 16-bit, and 32-bit data movement, plus addition, subtraction, and logical operations
- Single-cycle 16×16 -bit \rightarrow 32-bit and 32×32 -bit \rightarrow 64-bit multiplier-accumulator (MAC) with dual parallel moves
- 32-bit arithmetic and logic multi-bit shifter
- Four 36-bit accumulators, including extension bits
- Parallel instruction set with unique DSP addressing modes
- Hardware DO and REP loops
- Bit reverse address mode, which effectively supports DSP and Fast Fourier Transform algorithms
- Full shadowing of the register stack for zero-overhead context saves and restores: nine shadow registers correspond to nine address registers (R0, R1, R2, R3, R4, R5, N, N3, M01)
- Instruction set supports both DSP and controller functions
- Controller-style addressing modes and instructions enable compact code
- Enhanced bit manipulation instruction set
- Efficient C compiler and local variable support
- Software subroutine and interrupt stack, with the stack's depth limited only by memory
- Priority level setting for interrupt levels
- JTAG/Enhanced On-Chip Emulation (OnCE) for unobtrusive, real-time debugging that is independent of processor speed

1.3 Operation parameters

- Up to 60 MHz operation at $-40\text{ }^{\circ}\text{C}$ to $105\text{ }^{\circ}\text{C}$ ambient temperature
- Single 3.3 V power supply
- Supply range: $V_{DD} - V_{SS} = 2.7\text{ V}$ to 3.6 V , $V_{DDA} - V_{SSA} = 2.7\text{ V}$ to 3.6 V

1.4 On-chip memory and memory protection

- Modified dual Harvard architecture permits as many as three simultaneous accesses to program and data memory
- Internal flash memory with security and protection to prevent unauthorized access
- Memory resource protection (MRP) unit to protect supervisor programs and resources from user programs
- Programming code can reside in flash memory during flash programming
- The dual-ported RAM controller supports concurrent instruction fetches and data accesses, or dual data accesses, by the DSC core.

- Concurrent accesses provide increased performance.
- The data and instruction arrive at the core in the same cycle, reducing latency.
- On-chip memory
 - Up to 144 KW program/data flash memory, including FlexNVM
 - Up to 16 KW dual port data/program RAM
 - Up to 16 KW FlexNVM, which can be used as additional program or data flash memory
 - Up to 1 KW FlexRAM, which can be configured as enhanced EEPROM (used in conjunction with FlexNVM) or used as additional RAM

1.5 Interrupt Controller

- Five interrupt priority levels
 - Three user-programmable priority levels for each interrupt source: level 0, level 1, level 2
 - Unmaskable level 3 interrupts include illegal instruction, hardware stack overflow, misaligned data access, SWI3 instruction
 - Interrupt level 3 is highest priority and non-maskable. Its sources include:
 - Illegal instructions
 - Hardware stack overflow
 - SWI instruction
 - EOnce interrupts
 - Misaligned data accesses
 - Lowest-priority software interrupt: level LP
- Support for nested interrupts, so that a higher priority level interrupt request can interrupt lower priority interrupt subroutine
- Masking of interrupt priority level is managed by the 56800EX core
- Two programmable fast interrupts that can be assigned to any interrupt source
- Notification to System Integration Module (SIM) to restart clock when in wait and stop states
- Ability to relocate interrupt vector table

1.6 Peripheral highlights

1.6.1 Flex Pulse Width Modulator (FlexPWM)

- One PWM module contains 4 identical submodules, with up to 3 outputs per submodule, and up to 60 MHz PWM operating clock
- 16 bits of resolution for center, edge-aligned, and asymmetrical PWMs

- PWM outputs can be configured as complementary output pairs or independent outputs
- Dedicated time-base counter with period and frequency control per submodule
- Independent top and bottom deadtime insertion for each complementary pair
- Independent control of both edges of each PWM output
- Enhanced input capture and output compare functionality on each input:
 - Channels not used for PWM generation can be used for buffered output compare functions.
 - Channels not used for PWM generation can be used for input capture functions.
 - Enhanced dual edge capture functionality
- Synchronization of submodule to external hardware (or other PWM) is supported.
- Double-buffered PWM registers
 - Integral reload rates from 1 to 16
 - Half-cycle reload capability
- Multiple output trigger events can be generated per PWM cycle via hardware.
- Support for double-switching PWM outputs
- Up to eight fault inputs can be assigned to control multiple PWM outputs
 - Programmable filters for fault inputs
- Independently programmable PWM output polarity
- Individual software control of each PWM output
- All outputs can be programmed to change simultaneously via a FORCE_OUT event.
- PWMX pin can optionally output a third PWM signal from each submodule
- Option to supply the source for each complementary PWM signal pair from any of the following:
 - Crossbar module outputs
 - External ADC input, taking into account values set in ADC high and low limit registers

1.6.2 12-bit Analog-to-Digital Converter (Cyclic type)

- Two independent 12-bit analog-to-digital converters (ADCs):
 - 2 x 8-channel external inputs
 - Built-in x1, x2, x4 programmable gain pre-amplifier
 - Maximum ADC clock frequency up to 10 MHz, having period as low as 100-ns
 - Single conversion time of 8.5 ADC clock cycles
 - Additional conversion time of 6 ADC clock cycles
- Support of analog inputs for single-ended and differential conversions
- Sequential, parallel, and independent scan mode
- First 8 samples have offset, limit and zero-crossing calculation supported
- ADC conversions can be synchronized by *any* module connected to the internal crossbar module, such as PWM, timer, GPIO, and comparator modules.

- Support for simultaneous triggering and software-triggering conversions
- Support for a multi-triggering mode with a programmable number of conversions on each trigger
- Each ADC has ability to scan and store up to 8 conversion results.
- Current injection protection

1.6.3 Inter-Module Crossbar and AND-OR-INVERT logic

- Provides generalized connections between and among on-chip peripherals: ADCs, 12-bit DAC, comparators, quad-timers, FlexPWMs, PDBs, EWM, quadrature decoder, and select I/O pins
- User-defined input/output pins for all modules connected to the crossbar
- DMA request and interrupt generation from the crossbar
- Write-once protection for all registers
- AND-OR-INVERT function provides a universal Boolean function generator that uses a four-term sum-of-products expression, with each product term containing true or complement values of the four selected inputs (A, B, C, D).

1.6.4 Comparator

- Full rail-to-rail comparison range
- Support for high and low speed modes
- Selectable input source includes external pins and internal DACs
- Programmable output polarity
- 6-bit programmable DAC as a voltage reference per comparator
- Three programmable hysteresis levels
- Selectable interrupt on rising-edge, falling-edge, or toggle of a comparator output

1.6.5 12-bit Digital-to-Analog Converter

- 12-bit resolution
- Powerdown mode
- Automatic mode allows the DAC to automatically generate pre-programmed output waveforms, including square, triangle, and sawtooth waveforms (for applications like slope compensation)
- Programmable period, update rate, and range
- Output can be routed to an internal comparator, ADC, or optionally to an off-chip destination

1.6.6 Quad Timer

- Four 16-bit up/down counters, with a programmable prescaler for each counter
- Operation modes: edge count, gated count, signed count, capture, compare, PWM, signal shot, single pulse, pulse string, cascaded, quadrature decode
- Programmable input filter
- Counting start can be synchronized across counters

1.6.7 Queued Serial Communications Interface (QSCI) modules

- Operating clock can be up to two times the CPU operating frequency
- Four-word-deep FIFOs available on both transmit and receive buffers
- Standard mark/space non-return-to-zero (NRZ) format
- 13-bit integer and 3-bit fractional baud rate selection
- Full-duplex or single-wire operation
- Programmable 8-bit or 9-bit data format
- Error detection capability
- Two receiver wakeup methods:
 - Idle line
 - Address mark
- 1/16 bit-time noise detection

1.6.8 Queued Serial Peripheral Interface (QSPI) modules

- Maximum 25 Mbit/s baud rate
- Selectable baud rate clock sources for low baud rate communication
- Baud rate as low as $\text{Baudrate_Freq_in} / 8192$
- Full-duplex operation
- Master and slave modes
- Double-buffered operation with separate transmit and receive registers
- Four-word-deep FIFOs available on transmit and receive buffers
- Programmable length transmissions (2 bits to 16 bits)
- Programmable transmit and receive shift order (MSB as first bit transmitted)

1.6.9 Inter-Integrated Circuit (I2C)/System Management Bus (SMBus) modules

- Compatible with I2C bus standard
- Support for System Management Bus (SMBus) specification, version 2
- Multi-master operation

- General call recognition
- 10-bit address extension
- Start/Repeat and Stop indication flags
- Support for dual slave addresses or configuration of a range of slave addresses
- Programmable glitch input filter

1.6.10 Flex Controller Area Network (FlexCAN) module

- Clock source from PLL or XOSC/CLKIN
- Implementation of CAN protocol Version 2.0 A/B
- Standard and extended data frames
- Data length of 0 to 8 bytes
- Programmable bit rate up to 1 Mbps
- Support for remote frames
- Sixteen Message Buffers: each Message Buffer can be configured as receive or transmit, and supports standard and extended messages
- Individual Rx Mask Registers per Message Buffer
- Internal timer for time-stamping of received and transmitted messages
- Listen-only mode capability
- Programmable loopback mode, supporting self-test operation
- Programmable transmission priority scheme: lowest ID, lowest buffer number, or highest priority
- Global network time, synchronized by a specific message
- Low power modes, with programmable wakeup on bus activity

1.6.11 Computer Operating Properly (COP) watchdog

- Programmable timeout period
- Support for operation in all power modes: run mode, wait mode, stop mode
- Causes loss of reference reset 128 cycles after loss of reference clock to the PLL is detected
- Selectable reference clock source in support of EN60730 and IEC61508
- Selectable clock sources:
 - External crystal oscillator/external clock source
 - On-chip low-power 32 kHz oscillator
 - System bus (IPBus up to 60 MHz)
 - 8 MHz / 400 kHz ROSC
- Support for interrupt triggered when the counter reaches the timeout value

1.6.12 Power supervisor

- Power-on reset (POR) to reset CPU, peripherals, and JTAG/EOnCE controllers ($V_{DD} > 2.1$ V)
- Brownout reset ($V_{DD} < 1.9$ V)
- Critical warn low-voltage interrupt (LVI2.0)
- Peripheral low-voltage interrupt (LVI2.7)

1.6.13 Phase-locked loop

- Wide programmable output frequency: 240 MHz to 400 MHz
- Input reference clock frequency: 8 MHz to 16 MHz
- Detection of loss of lock and loss of reference clock
- Ability to power down

1.6.14 Clock sources

1.6.14.1 On-chip oscillators

- Tunable 8 MHz relaxation oscillator with 400 kHz at standby mode (divide-by-two output)
- 32 kHz low frequency clock as secondary clock source for COP, EWM, PIT

1.6.14.2 Crystal oscillator

- Support for both high ESR crystal oscillator (ESR greater than 100 Ω) and ceramic resonator
- Operating frequency: 4–16 MHz

1.6.15 Cyclic Redundancy Check (CRC) generator

- Hardware 16/32-bit CRC generator
- High-speed hardware CRC calculation
- Programmable initial seed value
- Programmable 16/32-bit polynomial
- Error detection for all single, double, odd, and most multi-bit errors

- Option to transpose input data or output data (CRC result) bitwise or bytewise,¹ which is required for certain CRC standards
- Option for inversion of final CRC result

1.6.16 General Purpose I/O (GPIO)

- 5 V tolerance (except RESETB pin)
- Individual control of peripheral mode or GPIO mode for each pin
- Programmable push-pull or open drain output
- Configurable pullup or pulldown on all input pins
- All pins (except JTAG and RESETB) default to be GPIO inputs
- 2 mA / 9 mA source/sink capability
- Controllable output slew rate

1.7 Block diagrams

The 56800EX core is based on a modified dual Harvard-style architecture, consisting of three execution units operating in parallel, and allowing as many as six operations per instruction cycle. The MCU-style programming model and optimized instruction set enable straightforward generation of efficient and compact code for the DSP and control functions. The instruction set is also efficient for C compilers, to enable rapid development of optimized control applications.

The device's basic architecture appears in [Figure 1](#) and [Figure 2](#). [Figure 1](#) shows how the 56800EX system buses communicate with internal memories, and the IPBus interface and the internal connections among the units of the 56800EX core. [Figure 2](#) shows the peripherals and control blocks connected to the IPBus bridge. See the specific device's Reference Manual for details.

1. A bytewise transposition is not possible when accessing the CRC data register via 8-bit accesses. In this case, user software must perform the bytewise transposition.

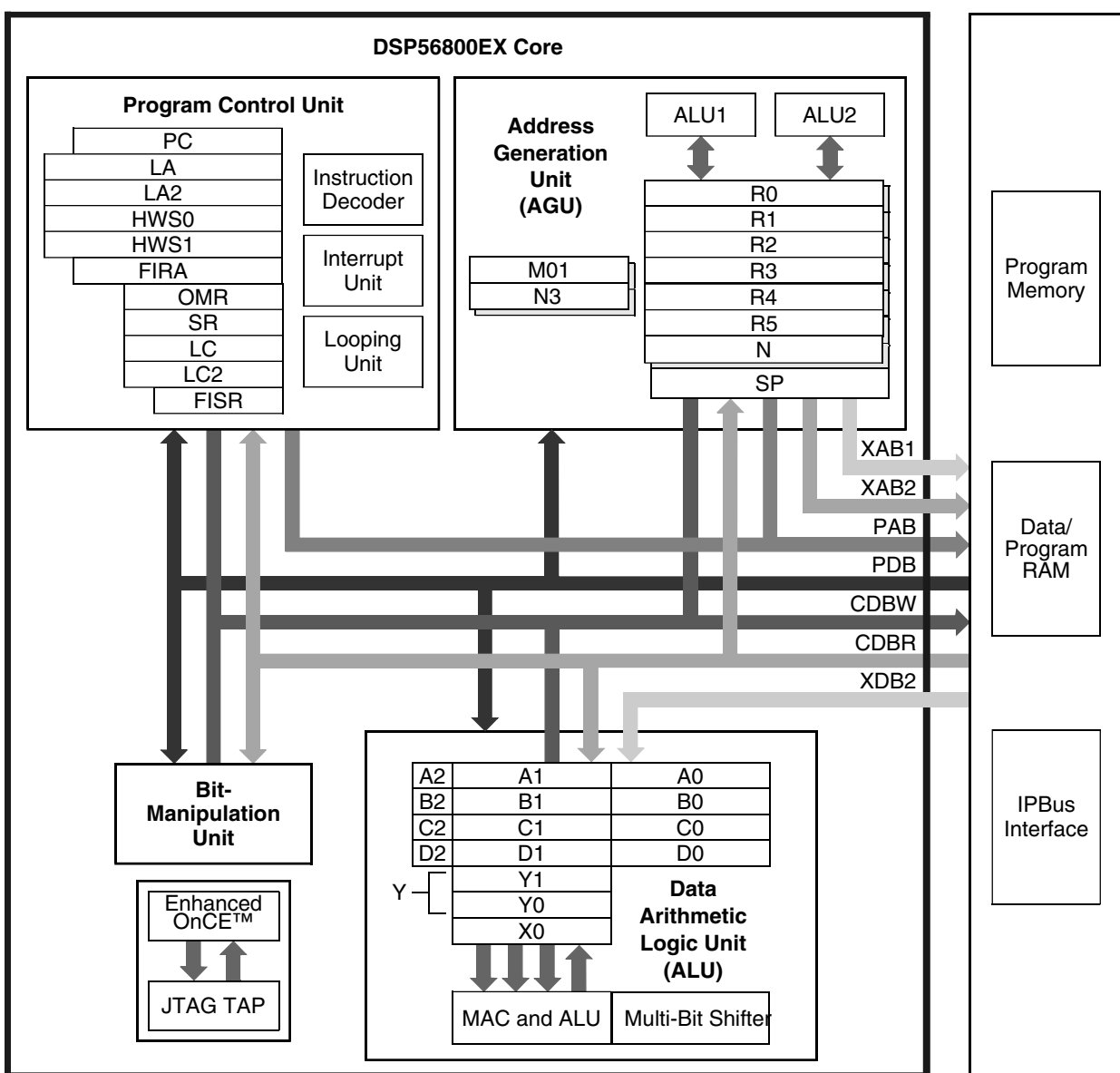

Figure 1. 56800EX basic block diagram

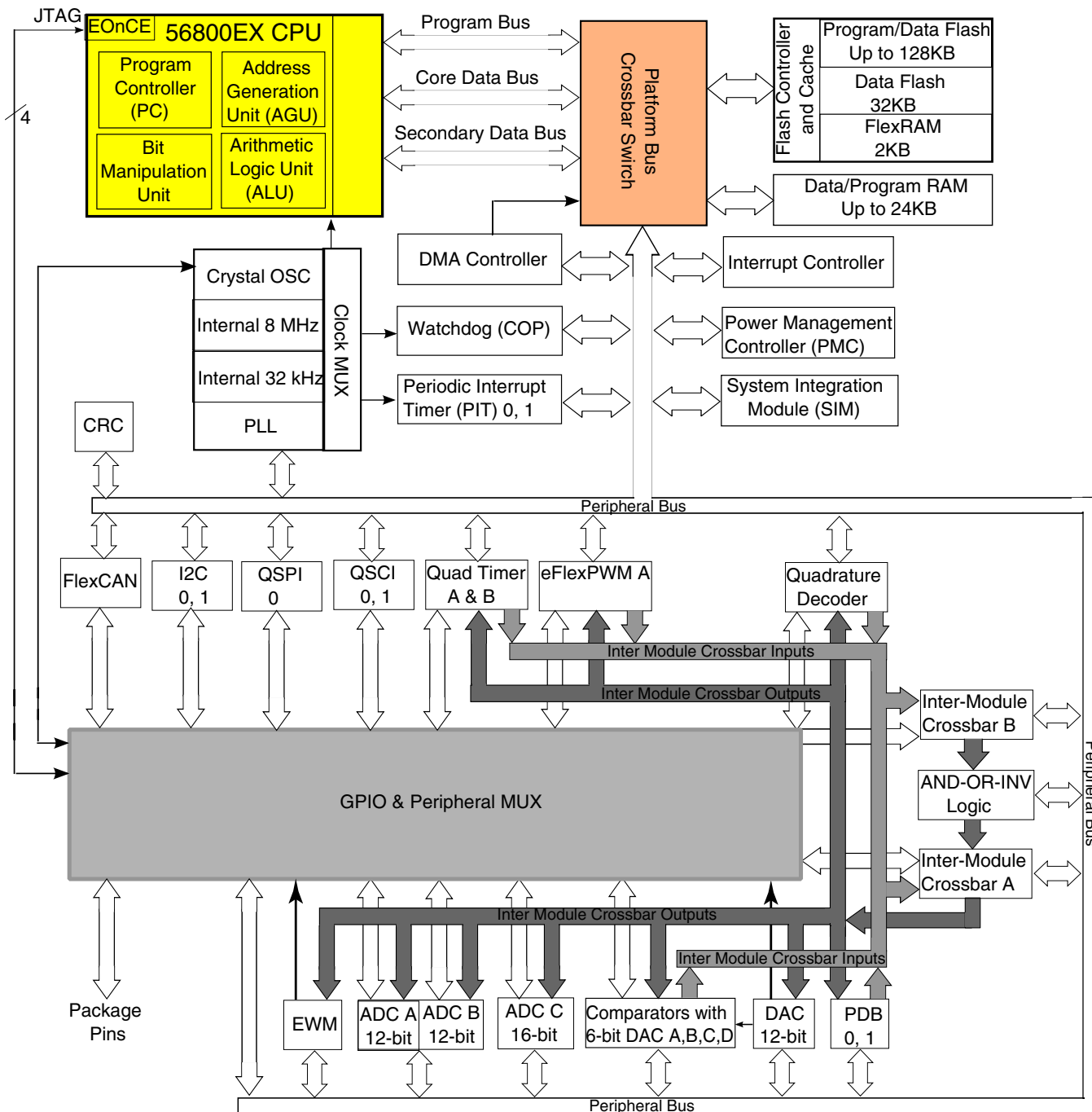

Figure 2. System diagram

2 MC56F844xx signal and pin descriptions

After reset, each pin is configured for its primary function (listed first). Any alternative functionality, shown in parentheses, must be programmed through the GPIO module peripheral enable registers (GPIO_x_PER) and the SIM module GPIO peripheral select (GPSx) registers. All GPIO ports can be individually programmed as an input or output (using bit manipulation).

- There are 2 PWM modules: PWMA, PWMB. Each PWM module has 4 submodules: PWMA has PWMA_0, PWMA_1, PWMA_2, PWMA_3; PWMB has PWMB_0, PWMB_1, PWMB_2, PWMB_3. Each PWM module's submodules have 3 pins (A, B, X) each, with the syntax for the pins being PWMA_0A, PWMA_0B, PWMA_0X, and PWMA_1A, PWMA_1B, PWMA_1X, and so on. Each submodule pin can be configured as a PWM output or as a capture input.
- EWM_OUT_B is the output of the External Watchdog Module (EWM), and is active low (denoted by the "_B" part of the syntax).

For the MC56F844XX products, which use 48-pin LQFP and 64-pin LQFP packages:

Table 2. Signal descriptions

Signal Name	64 LQFP	48 LQFP	Type	State During Reset ¹	Signal Description
V _{DD}	29	-	Supply	Supply	I/O Power — Supplies 3.3 V power to the chip I/O interface.
V _{DD}	44	32			
V _{DD}	60	44			
V _{SS}	30	22	Supply	Supply	I/O Ground — Provide ground for the device I/O interface.
V _{SS}	43	31			
V _{SS}	61	45			
V _{DDA}	22	15	Supply	Supply	Analog Power — Supplies 3.3 V power to the analog modules. It must be connected to a clean analog power supply.
V _{SSA}	23	16	Supply	Supply	Analog Ground — Supplies an analog ground to the analog modules. It must be connected to a clean power supply.
V _{CAP}	26	19	On-chip regulator output voltage	On-chip regulator output voltage	Connect a 2.2uF or greater bypass capacitor between this pin and V _{SS} to stabilize the core voltage regulator output required for proper device operation. V _{CAP} is used to observe core voltage.
V _{CAP}	57	43			

Table continues on the next page...

Table 2. Signal descriptions (continued)

Signal Name	64 LQFP	48 LQFP	Type	State During Reset ¹	Signal Description
TDI	64	48	Input	Input, internal pullup enabled	Test Data Input — Provides a serial input data stream to the JTAG/EOnCE port. It is sampled on the rising edge of TCK and has an internal pullup resistor. After reset, the default state is TDI.
(GPIOD0)			Input/Output	Input, internal pullup enabled	GPIO Port D0
TDO	62	46	Output	Output	Test Data Output — This tri-stateable pin provides a serial output data stream from the JTAG/EOnCE port. It is driven in the shift-IR and shift-DR controller states, and it changes on the falling edge of TCK. After reset, the default state is TDO.
(GPIOD1)			Input/Output	Input, internal pullup enabled	GPIO Port D1
TCK	1	1	Input	Input, internal pullup enabled	Test Clock Input — This input pin provides a gated clock to synchronize the test logic and shift serial data to the JTAG/EOnCE port. The pin is connected internally to a pullup resistor. A Schmitt-trigger input is used for noise immunity. After reset, the default state is TCK.
(GPIOD2)			Input/Output	Input, internal pullup enabled	GPIO Port D2
TMS	63	47	Input	Input, internal pullup enabled	Test Mode Select Input — Used to sequence the JTAG TAP controller state machine. It is sampled on the rising edge of TCK and has an internal pullup resistor. After reset, the default state is TMS. NOTE: Always tie the TMS pin to V_{DD} through a 2.2K resistor, if needed to keep an on-board debug capability. Otherwise, tie the TMS pin directly to V_{DD} .
(GPIOD3)			Input/Output	Input, internal pullup enabled	GPIO Port D2

Table continues on the next page...

Table 2. Signal descriptions (continued)

Signal Name	64 LQFP	48 LQFP	Type	State During Reset ¹	Signal Description
RESET or RESETB	2	2	Input	Input, internal pullup enabled (This pin is 3.3V only.)	Reset — A direct hardware reset on the processor. When RESET is asserted low, the device is initialized and placed in the reset state. A Schmitt-trigger input is used for noise immunity. The internal reset signal is deasserted synchronously with the internal clocks after a fixed number of internal clocks. After reset, the default state is RESET. To filter noise on the RESETB pin, install a capacitor (up to 0.1 uF) on it.
(GPIO4)			Input/ Open-drain Output	Input, internal pullup enabled	GPIO Port D4 RESET functionality is disabled in this mode and the device can be reset only through Power-On Reset (POR), COP reset, or software reset.
GPIOA0	13	9	Input/Output	Input	GPIO Port A0: After reset, the default state is GPIOA0.
(ANA0&CMPA_IN3)			Input		ANA0 is input to channel 0 of ADCA; CMPA_IN3 is input 3 of analog comparator A. When used as an analog input, the signal goes to both places (ANA0 and CMPA_IN3), but the glitch on this pin during ADC sampling may interfere with other analog inputs shared on this pin.
(CMPC_O)			Output		Analog comparator C output
GPIOA1	14	10	Input/Output	Input	GPIO Port A1: After reset, the default state is GPIOA1.
(ANA1&CMPA_IN0)			Input		ANA1 is input to channel 1 of ADCA; CMPA_IN0 is input 0 of analog comparator A. When used as an analog input, the signal goes to both places (ANA1 and CMPA_IN0), but the glitch on this pin during ADC sampling may interfere with other analog inputs shared on this pin.
GPIOA2	15	11	Input/Output	Input	GPIO Port A2: After reset, the default state is GPIOA2.
(ANA2&VREFHA&CMPA_IN1)			Input		ANA2 is input to channel 2 of ADCA; VREFHA is the reference high of ADCA; CMPA_IN1 is input 1 of analog comparator A. When used as an analog input, the signal goes to both places (ANA2 and CMPA_IN1), but the glitch on this pin during ADC sampling may interfere with other analog inputs shared on this pin. This input can be configured as either ANA2 or VREFHA using the ADCA control register.

Table continues on the next page...

Table 2. Signal descriptions (continued)

Signal Name	64 LQFP	48 LQFP	Type	State During Reset ¹	Signal Description
GPIOA3	16	12	Input/Output	Input	GPIO Port A3: After reset, the default state is GPIOA3.
(ANA3&VREFLA&CMPA_IN2)			Input		ANA3 is input to channel 3 of ADCA; VREFLA is the reference low of ADCA; CMPA_IN2 is input 2 of analog comparator A. When used as an analog input, the signal goes to both places (ANA3 and CMPA_IN2), but the glitch on this pin during ADC sampling may interfere with other analog inputs shared on this pin. This input can be configured as either ANA3 or VREFLA using the ADCA control register.
GPIOA4	12	8	Input/Output	Input	GPIO Port A4: After reset, the default state is GPIOA4.
(ANA4&ANC8&CMPD_IN0)			Input		ANA4 is input to channel 4 of ADCA; ANC8 is input to channel 8 of ADCC; CMPD_IN0 is input 0 to comparator D. When used as an analog input, the signal goes to all three places (ANA4 and ANC8 and CMPA_IN0), but the glitch on this pin during ADC sampling may interfere with other analog inputs shared on this pin.
GPIOA5	11	-	Input/Output	Input	GPIO Port A5: After reset, the default state is GPIOA5.
(ANA5&ANC9)			Input		ANA5 is input to channel 5 of ADCA; ANC9 is input to channel 9 of ADCC. When used as an analog input, the signal goes to both places (ANA5 and ANC9), but the glitch on this pin during ADC sampling may interfere with other analog inputs shared on this pin.
GPIOA6	10	-	Input/ Output	Input	GPIO Port A6: After reset, the default state is GPIOA6.
(ANA6&ANC10)			Input		ANA6 is input to channel 5 of ADCA; ANC10 is input to channel 10 of ADCC. When used as an analog input, the signal goes to both places (ANA6 and ANC10), but the glitch on this pin during ADC sampling may interfere with other analog inputs shared on this pin.
GPIOA7	9	-	Input/Output	Input	GPIO Port A7: After reset, the default state is GPIOA7.
(ANA7&ANC11)			Input		ANA7 is input to channel 7 of ADCA; ANC11 is input to channel 11 of ADCC. When used as an analog input, the signal goes to both places (ANA7 and ANC11), but the glitch on this pin during ADC sampling may interfere with other analog inputs shared on this pin.

Table continues on the next page...

Table 2. Signal descriptions (continued)

Signal Name	64 LQFP	48 LQFP	Type	State During Reset ¹	Signal Description
GPIOB0	24	17	Input/Output	Input	GPIO Port B0: After reset, the default state is GPIOB0.
(ANB0&CMPB_IN3)			Input		ANB0 is input to channel 0 of ADCB; CMPB_IN3 is input 3 of analog comparator B. When used as an analog input, the signal goes to both places (ANB0 and CMPB_IN3), but the glitch on this pin during ADC sampling may interfere with other analog inputs shared on this pin.
GPIOB1	25	18	Input/ Output	Input	GPIO Port B1: After reset, the default state is GPIOB1.
(ANB1&CMPB_IN0)			Input		ANB1 is input to channel 1 of ADCB; CMPB_IN0 is input 0 of analog comparator B. When used as an analog input, the signal goes to both places (ANB1 and CMPB_IN0), but the glitch on this pin during ADC sampling may interfere with other analog inputs shared on this pin.
GPIOB2	27	20	Input/ Output	Input	GPIO Port B2: After reset, the default state is GPIOB2.
(ANB2&VREFHB&CMPC_IN3)			Input		ANB2 is input to channel 2 of ADCB; VREFHB is the reference high of ADCB; CMPC_IN3 is input 3 of analog comparator C. When used as an analog input, the signal goes to both places (ANB2 and CMPC_IN3), but the glitch during ADC sampling on this pin may interfere with other analog inputs shared on this pin. This input can be configured as either ANB2 or VREFHB using the ADCB control register.
GPIOB3	28	21	Input/ Output	Input	GPIO Port B3: After reset, the default state is GPIOB3.
(ANB3&VREFLB&CMPC_IN0)			Input		ANB3 is input to channel 3 of ADCB; VREFLB is the reference low of ADCB; CMPC_IN0 is input 0 of analog comparator C. When used as an analog input, the signal goes to both places (ANB3 and CMPC_IN0), but the glitch during ADC sampling on this pin may interfere with other analog inputs shared on this pin. This input can be configured as either ANB3 or VREFLB using the ADCB control register.
GPIOB4	21	14	Input/ Output	Input	GPIO Port B4: After reset, the default state is GPIOB4.
(ANB4&ANC12&CMPC_IN1)			Input		ANB4 is input to channel 4 of ADCB; ANC12 is input to channel 12 of ADCC; CMPC_IN1 is input 1 of analog comparator C. When used as an analog input, the signal goes to all three places (ANB4 and ANC12 and CMPC_IN1), but the glitch during ADC sampling on this pin may interfere with other analog inputs shared on this pin.

Table continues on the next page...

Table 2. Signal descriptions (continued)

Signal Name	64 LQFP	48 LQFP	Type	State During Reset ¹	Signal Description
GPIOB5	20	-	Input/ Output	Input	GPIO Port B5: After reset, the default state is GPIOB5.
(ANB5&ANC13&CMPC_IN2)			Input		ANB5 is input to channel 5 of ADCB; ANC13 is input to channel 13 of ADCC; CMPC_IN2 is input 2 of analog comparator C. When used as an analog input, the signal goes to all three places (ANB5 and ANC13 and CMPC_IN2), but the glitch during ADC sampling on this pin may interfere with other analog inputs shared on this pin.
GPIOB6	19	-	Input/ Output	Input	GPIO Port B6: After reset, the default state is GPIOB6.
(ANB6&ANC14&CMPB_IN1)			Input		ANB6 is input to channel 6 of ADCB; ANC14 is input to channel 14 of ADCC; CMPB_IN1 is input 1 of analog comparator B. When used as an analog input, the signal goes to all three places (ANB6 and ANC14 and CMPB_IN1), but the glitch during ADC sampling on this pin may interfere with other analog inputs shared on this pin.
GPIOB7	17	-	Input/ Output	Input	GPIO Port B7: After reset, the default state is GPIOB7.
(ANB7&ANC15&CMPB_IN2)			Input		ANB7 is input to channel 7 of ADCB; ANC15 is input to channel 15 of ADCC; CMPB_IN2 is input 2 of analog comparator B. When used as an analog input, the signal goes to all three places (ANB7 and ANC15 and CMPB_IN2), but the glitch during ADC sampling on this pin may interfere with other analog inputs shared on this pin.
GPIOC0	3	3	Input/Output	Input	GPIO Port C0: After reset, the default state is GPIOC0.
EXTAL			Analog Input		The external crystal oscillator input (EXTAL) connects the internal crystal oscillator input to an external crystal or ceramic resonator.
CLKIN0			Input		External clock input 0. ²
GPIOC1	4	4	Input/Output	Input	GPIO Port C1: After reset, the default state is GPIOC1.
(XTAL)			Analog Output		The external crystal oscillator output (XTAL) connects the internal crystal oscillator output to an external crystal or ceramic resonator.

Table continues on the next page...

Table 2. Signal descriptions (continued)

Signal Name	64 LQFP	48 LQFP	Type	State During Reset ¹	Signal Description
GPIOC2	5	5	Input/Output	Input	GPIO Port C2: After reset, the default state is GPIOC2.
(TXD0)			Output		SCI0 transmit data output or transmit/receive in single-wire operation
(TB0)			Input/Output		Quad timer module B channel 0 input/output
(XB_IN2)			Input		Crossbar module input 2
(CLKO0)			Output		Buffered clock output 0: the clock source is selected by clockout select (CLKOSEL) bits in the clock output select register (CLKOUT) of the SIM.
GPIOC3	7	6	Input/ Output	Input	GPIO Port C3: After reset, the default state is GPIOC3.
(TA0)			Input/ Output		Quad timer module A channel 0 input/output
(CMPA_O)			Output		Analog comparator A output
(RXD0)			Input		SCI0 receive data input
(CLKIN1)			Input		External clock input 1
GPIOC4	8	7	Input/ Output	Input	GPIO Port C4: After reset, the default state is GPIOC4.
(TA1)			Input/ Output		Quad timer module A channel 1 input/output
(CMPB_O)			Output		Analog comparator B output
(XB_IN8)			Input		Crossbar module input 8
(EWM_OUT_B)			Output		External Watchdog Module output
GPIOC5	18	13	Input/ Output	Input	GPIO Port C5: After reset, the default state is GPIOC5.
(DACO)			Analog Output		12-bit digital-to-analog output
(XB_IN7)			Input		Crossbar module input 7
GPIOC6	31	23	Input/ Output	Input,	GPIO Port C6: After reset, the default state is GPIOC6.
(TA2)			Input/ Output		Quad timer module A channel 2 input/output
(XB_IN3)			Input		Crossbar module input 3
(CMP_REF)			Analog Input		Positive input 5 of analog comparator A and B and C and D. Note: MC56F84451 and MC56F84441 do not have CMPD.
GPIOC7	32	24	Input/ Output	Input	GPIO Port C7: After reset, the default state is GPIOC7.
(SS0_B)			Input/ Output		In slave mode, $\overline{SS0_B}$ indicates to the SPI module 0 that the current transfer is to be received.
(TXD0)			Output		SCI0 transmit data output or transmit/receive in single-wire operation

Table continues on the next page...

Table 2. Signal descriptions (continued)

Signal Name	64 LQFP	48 LQFP	Type	State During Reset ¹	Signal Description
GPIOC8	33	25	Input/Output	Input	GPIO Port C8: After reset, the default state is GPIOC8.
(MISO0)			Input/Output		Master in/slave out for SPI0 — In master mode, MISO0 pin is the data input. In slave mode, MISO0 pin is the data output. The MISO line of a slave device is placed in the high-impedance state if the slave device is not selected.
(RXD0)			Input		SCI0 receive data input
(XB_IN9)			Input		Crossbar module input 9
GPIOC9	34	26	Input/ Output	Input	GPIO Port C9: After reset, the default state is GPIOC9.
(SCK0)			Input/ Output		SPI0 serial clock. In master mode, SCK0 pin is an output, clocking slaved listeners. In slave mode, SCK0 pin is the data clock input.
(XB_IN4)			Input		Crossbar module input 4
GPIOC10	35	27	Input/ Output	Input	GPIO Port C10: After reset, the default state is GPIOC10.
(MOSI0)			Input/ Output		Master out/slave in for SPI0 — In master mode, MOSI0 pin is the data output. In slave mode, MOSI0 pin is the data input.
(XB_IN5)			Input		Crossbar module input 5
(MISO0)			Input/ Output		Master in/slave out for SPI0 — In master mode, MISO0 pin is the data input. In slave mode, MISO0 pin is the data output. The MISO line of a slave device is placed in the high-impedance state if the slave device is not selected.
GPIOC11	37	29	Input/Output	Input	GPIO Port C11: After reset, the default state is GPIOC11.
(CANTX)			Open-drain Output		CAN transmit data output
(SCL1)			Input/ Open-drain Output		I ² C1 serial clock
(TXD1)			Output		SCI1 transmit data output or transmit/receive in single wire operation
GPIOC12	38	30	Input/ Output	Input	GPIO Port C12: After reset, the default state is GPIOC12.
(CANRX)			Input		CAN receive data input
(SDA1)			Input/ Open-drain Output		I ² C1 serial data line
(RXD1)			Input		SCI1 receive data input

Table continues on the next page...

Table 2. Signal descriptions (continued)

Signal Name	64 LQFP	48 LQFP	Type	State During Reset ¹	Signal Description
GPIOC13	49	37	Input/ Output	Input,	GPIO Port C13: After reset, the default state is GPIOC13.
(TA3)			Input/ Output		Quad timer module A channel 3 input/output
(XB_IN6)			Input		Crossbar module input 6
(EWM_OUT_B)			Output		External Watchdog Module output
GPIOC14	55	41	Input/ Output	Input	GPIO Port C14: After reset, the default state is GPIOC14.
(SDA0)			Input/ Open-drain Output		I ² C0 serial data line
(XB_OUT4)			Input		Crossbar module output 4
GPIOC15	56	42	Input/ Output	Input	GPIO Port C15: After reset, the default state is GPIOC15.
(SCL0)			Input/ Open-drain Output		I ² C0 serial clock
(XB_OUT5)			Input		Crossbar module output 5
GPIOE0	45	33	Input/ Output	Input	GPIO Port E0: After reset, the default state is GPIOE0.
PWMA_0B			Input/ Output		PWM module A, submodule 0, output B or input capture B
GPIOE1	46	34	Input/ Output	Input	GPIO Port E1: After reset, the default state is GPIOE1.
(PWMA_0A)			Input/ Output		PWM module A, submodule 0, output A or input capture A
GPIOE2	47	35	Input/ Output	Input	GPIO Port E2: After reset, the default state is GPIOE2.
(PWMA_1B)			Input/ Output		PWM module A, submodule 1, output B or input capture B
GPIOE3	48	38	Input/ Output	Input	GPIO Port E3: After reset, the default state is GPIOE3.
(PWMA_1A)			Input/ Output		PWM module A, submodule 1, output A or input capture A
GPIOE4	51	39	Input/ Output	Input	GPIO Port E4: After reset, the default state is GPIOE4.
(PWMA_2B)			Input/ Output		PWM module A, submodule 2, output B or input capture B
(XB_IN2)			Input		Crossbar module input 2
GPIOE5	52	40	Input/ Output	Input	GPIO Port E5: After reset, the default state is GPIOE5.
(PWMA_2A)			Input/ Output		PWM module A, submodule 2, output A or input capture A
(XB_IN3)			Input		Crossbar module input 3

Table continues on the next page...

Table 2. Signal descriptions (continued)

Signal Name	64 LQFP	48 LQFP	Type	State During Reset ¹	Signal Description
GPIOE6	53	-	Input/ Output	Input	GPIO Port E6: After reset, the default state is GPIOE6.
(PWMA_3B)			Input/ Output		PWM module A, submodule 3, output B or input capture B
(XB_IN4)			Input		Crossbar module input 4
(PWMB_2B)			Input/ Output		PWM module B, submodule 2, output B or input capture B
GPIOE7	54	-	Input/ Output	Input	GPIO Port E7: After reset, the default state is GPIOE7.
(PWMA_3A)			Input/ Output		PWM module A, submodule 3, output A or input capture A
(XB_IN5)			Input		Crossbar module input 5
(PWMB_2A)			Input/ Output		PWM module B, submodule 2, output A or input capture A
GPIOF0	36	28	Input/ Output	Input	GPIO Port F0: After reset, the default state is GPIOF0.
(XB_IN6)			Input		Crossbar module input 6
(TB2)			Input/ Output		Quad timer module B Channel 2 input/output
GPIOF1	50	38	Input/ Output	Input	GPIO Port F1: After reset, the default state is GPIOF1.
(CLKO1)			Output		Buffered clock output 1: the clock source is selected by clockout select (CLKOSEL) bits in the clock output select register (CLKOUT) of the SIM.
(XB_IN7)			Input		Crossbar module input 7
(CMPD_O)			Output		Analog comparator D output
GPIOF2	39	-	Input/ Output	Input	GPIO Port F2: After reset, the default state is GPIOF2.
(SCL1)			Input/ Open-drain Output		I ² C1 serial clock
(XB_OUT6)			Output		Crossbar module output 6
GPIOF3	40	-	Input/ Output	Input	GPIO Port F3: After reset, the default state is GPIOF3.
(SDA1)			Input/ Open-drain Output		I ² C1 serial data line
(XB_OUT7)			Output		Crossbar module output 7
GPIOF4	41	-	Input/ Output	Input	GPIO Port F4: After reset, the default state is GPIOF4.
(TXD1)			Output		SCI1 transmit data output or transmit/receive in single wire operation
(XB_OUT8)			Output		Crossbar module output 8

Table continues on the next page...

Table 2. Signal descriptions (continued)

Signal Name	64 LQFP	48 LQFP	Type	State During Reset ¹	Signal Description
GPIOF5	42	-	Input/ Output	Input	GPIO Port F5: After reset, the default state is GPIOF5.
(RXD1)			Output		SCI1 receive data input
(XB_OUT9)			Output		Crossbar module output 9
GPIOF6	58	-	Input/ Output	Input	GPIO Port F6: After reset, the default state is GPIOF6.
(TB2)			Input/ Output		Quad timer module B Channel 2 input/output
(PWMA_3X)			Input/ Output		PWM module A, submodule 3, output X or input capture X
(PWMB_3X)			Input/ Output		PWM module B, submodule 3, output X or input capture X
(XB_IN2)			Input		Crossbar module input 2
GPIOF7	59	-	Input/ Output	Input	GPIO Port F7: After reset, the default state is GPIOF7.
(TB3)			Input/ Output		Quad timer module B Channel 3 input/output
(CMPC_O)			Output		Analog comparator C output
(XB_IN3)			Input		Crossbar module input 3
GPIOF8	6	-	Input/ Output		GPIO Port F8: After reset, the default state is GPIOF8.
(RXD0)			Input		SCI0 receive data input
(TB1)			Input/ Output		Quad timer module B Channel 1 input/output
(CMPD_O)			Output		Analog comparator D output

1. For all GPIO except GPIOD0 - GPIOD4, input only after reset (internal pullup and pull-down are disabled).
2. If CLKIN is selected as the device's external clock input, then both the GPS_C0 bit (in GPS1) and the EXT_SEL bit (in OCCS oscillator control register (OSCTL)) must be set. Also, the crystal oscillator should be powered down.

3 Signal groups

The input and output signals of the MC56F84xxx are organized into functional groups, as listed in [Table 3](#). Note that some package sizes may not be available for your specific product. See [MC56F844xx/5xx/7xx product family](#).

Table 3. Functional Group Pin Allocations

Functional Group	Number of Pins			
	48 LQFP	64 LQFP	80 LQFP	100 LQFP
Power Inputs (V _{DD} , V _{DDA}), Power Outputs (V _{CAP})	5	6	6	6
Ground (V _{SS} , V _{SSA})	4	4	5	6
Reset	1	1	1	1

Table continues on the next page...

**Table 3. Functional Group Pin Allocations
(continued)**

Functional Group	Number of Pins			
	48 LQFP	64 LQFP	80 LQFP	100 LQFP
eFlexPWM ports, not including fault pins	6	9	N/A	N/A
Queued Serial Peripheral Interface (QSPI) ports	5	5	8	15
Queued Serial Communications Interface (QSCI) ports	6	9	9	15
Inter-Integrated Circuit (I ² C) interface ports	4	6	6	6
12-bit Analog-to-Digital Converter (Cyclic ADC) inputs	10	16	16	16
16-bit Analog-to-Digital Converter (SAR ADC) inputs	2	8	10	16
Analog Comparator inputs/outputs	10/4	13/6	13/6	16/6
12-bit Digital-to-Analog output	1	1	1	1
Quad Timer Module (TMR) ports	6	9	11	13
Controller Area Network (FlexCAN)	2	2	2	2
Inter-Module Crossbar inputs/outputs	12/2	16/6	19/17	25/19
Clock inputs/outputs	2/2	2/2	2/3	2/3
JTAG / Enhanced On-Chip Emulation (EOnCE)	4	4	4	4

4 Ordering parts

4.1 Determining valid orderable parts

Valid orderable part numbers are provided on the web. To determine the orderable part numbers for this device, go to freescale.com and perform a part number search for the following device numbers: MC56F84

5 Part identification

5.1 Description

Part numbers for the chip have fields that identify the specific part. You can use the values of these fields to determine the specific part you have received.

5.2 Format

Part numbers for this device have the following format: Q 56F8 4 C F P T PP N

5.3 Fields

This table lists the possible values for each field in the part number (not all combinations are valid):

Field	Description	Values
Q	Qualification status	<ul style="list-style-type: none"> MC = Fully qualified, general market flow PC = Prequalification
56F8	DSC family with flash memory and DSP56800/DSP56800E/DSP56800EX core	<ul style="list-style-type: none"> 56F8
4	DSC subfamily	<ul style="list-style-type: none"> 4
C	Maximum CPU frequency (MHz)	<ul style="list-style-type: none"> 4 = 60 MHz 5 = 80 MHz 7 = 100 MHz
F	Primary program flash memory size	<ul style="list-style-type: none"> 4 = 64 KB 5 = 96 KB 6 = 128 KB 8 = 256 KB
P	Pin count	<ul style="list-style-type: none"> 0 and 1 = 48 2 and 3 = 64 4, 5, and 6 = 80 7, 8, and 9 = 100
T	Temperature range (°C)	<ul style="list-style-type: none"> V = -40 to 105
PP	Package identifier	<ul style="list-style-type: none"> LF = 48LQFP LH = 64LQFP LK = 80LQFP LL = 100LQFP
N	Packaging type	<ul style="list-style-type: none"> R = Tape and reel (Blank) = Trays

5.4 Example

This is an example part number: MC56F84789VLL

6 Terminology and guidelines

6.1 Definition: Operating requirement

An *operating requirement* is a specified value or range of values for a technical characteristic that you must guarantee during operation to avoid incorrect operation and possibly decreasing the useful life of the chip.

6.1.1 Example

This is an example of an operating requirement:

Symbol	Description	Min.	Max.	Unit
V _{DD}	1.0 V core supply voltage	0.9	1.1	V

6.2 Definition: Operating behavior

An *operating behavior* is a specified value or range of values for a technical characteristic that are guaranteed during operation if you meet the operating requirements and any other specified conditions.

6.2.1 Example

This is an example of an operating behavior:

Symbol	Description	Min.	Max.	Unit
I _{WP}	Digital I/O weak pullup/pulldown current	10	130	μA

6.3 Definition: Attribute

An *attribute* is a specified value or range of values for a technical characteristic that are guaranteed, regardless of whether you meet the operating requirements.

6.3.1 Example

This is an example of an attribute:

Terminology and guidelines

Symbol	Description	Min.	Max.	Unit
CIN_D	Input capacitance: digital pins	—	7	pF

6.4 Definition: Rating

A *rating* is a minimum or maximum value of a technical characteristic that, if exceeded, may cause permanent chip failure:

- *Operating ratings* apply during operation of the chip.
- *Handling ratings* apply when the chip is not powered.

6.4.1 Example

This is an example of an operating rating:

Symbol	Description	Min.	Max.	Unit
V _{DD}	1.0 V core supply voltage	−0.3	1.2	V

6.5 Result of exceeding a rating

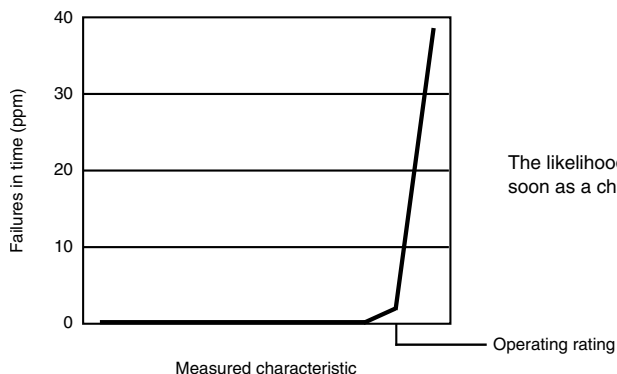

The likelihood of permanent chip failure increases rapidly as soon as a characteristic begins to exceed one of its operating ratings.

6.6 Relationship between ratings and operating requirements

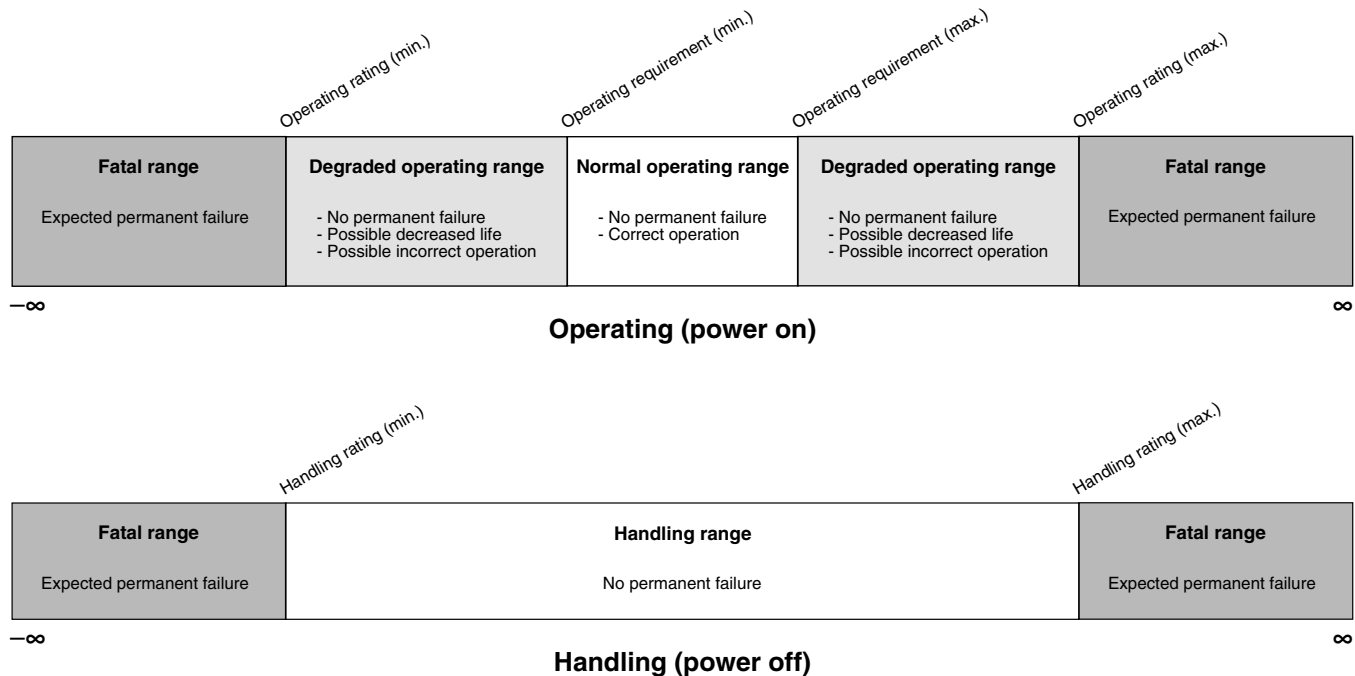

6.7 Guidelines for ratings and operating requirements

Follow these guidelines for ratings and operating requirements:

- Never exceed any of the chip's ratings.
- During normal operation, don't exceed any of the chip's operating requirements.
- If you must exceed an operating requirement at times other than during normal operation (for example, during power sequencing), limit the duration as much as possible.

6.8 Definition: Typical value

A *typical value* is a specified value for a technical characteristic that:

- Lies within the range of values specified by the operating behavior
- Given the typical manufacturing process, is representative of that characteristic during operation when you meet the typical-value conditions or other specified conditions

Typical values are provided as design guidelines and are neither tested nor guaranteed.

6.8.1 Example 1

This is an example of an operating behavior that includes a typical value:

Symbol	Description	Min.	Typ.	Max.	Unit
I_{WP}	Digital I/O weak pullup/pulldown current	10	70	130	μA

6.8.2 Example 2

This is an example of a chart that shows typical values for various voltage and temperature conditions:

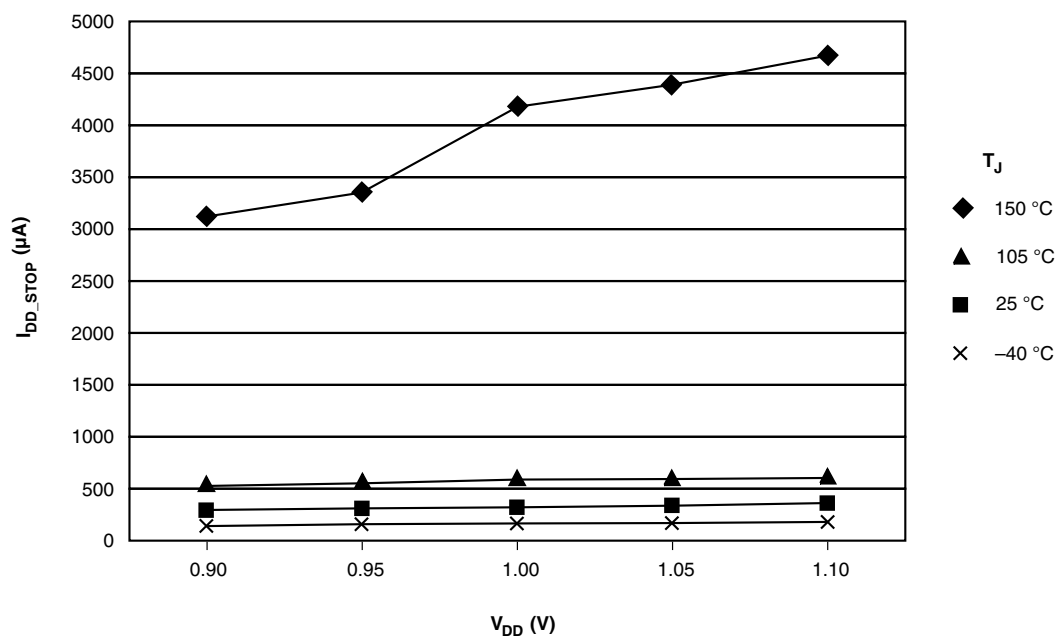

6.9 Typical value conditions

Typical values assume you meet the following conditions (or other conditions as specified):

Symbol	Description	Value	Unit
T_A	Ambient temperature	25	$^{\circ}\text{C}$
V_{DD}	3.3 V supply voltage	3.3	V

7 Ratings

7.1 Thermal handling ratings

Symbol	Description	Min.	Max.	Unit	Notes
T _{STG}	Storage temperature	-55	150	°C	1
T _{SDR}	Solder temperature, lead-free	—	260	°C	2

1. Determined according to JEDEC Standard JESD22-A103, *High Temperature Storage Life*.
2. Determined according to IPC/JEDEC Standard J-STD-020, *Moisture/Reflow Sensitivity Classification for Nonhermetic Solid State Surface Mount Devices*.

7.2 Moisture handling ratings

Symbol	Description	Min.	Max.	Unit	Notes
MSL	Moisture sensitivity level	—	3	—	1

1. Determined according to IPC/JEDEC Standard J-STD-020, *Moisture/Reflow Sensitivity Classification for Nonhermetic Solid State Surface Mount Devices*.

7.3 ESD handling ratings

Although damage from electrostatic discharge (ESD) is much less common on these devices than on early CMOS circuits, use normal handling precautions to avoid exposure to static discharge. Qualification tests are performed to ensure that these devices can withstand exposure to reasonable levels of static without suffering any permanent damage.

All ESD testing is in conformity with AEC-Q100 Stress Test Qualification. During the device qualification ESD stresses were performed for the human body model (HBM), the machine model (MM), and the charge device model (CDM).

All latch-up testing is in conformity with AEC-Q100 Stress Test Qualification.

A device is defined as a failure if after exposure to ESD pulses, the device no longer meets the device specification. Complete DC parametric and functional testing is performed as per the applicable device specification at room temperature followed by hot temperature, unless specified otherwise in the device specification.

Table 4. ESD/Latch-up Protection

Characteristic ¹	Min	Max	Unit
ESD for Human Body Model (HBM)	-2000	+2000	V
ESD for Machine Model (MM)	-200	+200	V
ESD for Charge Device Model (CDM)	-500	+500	V
Latch-up current at TA= 85°C (I _{LAT})	-100	+100	mA

1. Parameter is achieved by design characterization on a small sample size from typical devices under typical conditions unless otherwise noted.

7.4 Voltage and current operating ratings

Absolute maximum ratings are stress ratings only, and functional operation at the maxima is not guaranteed. Stress beyond the limits specified in [Table 5](#) may affect device reliability or cause permanent damage to the device.

Table 5. Absolute Maximum Ratings (V_{SS} = 0 V, V_{SSA} = 0 V)

Characteristic	Symbol	Notes ¹	Min	Max	Unit
Supply Voltage Range	V _{DD}		-0.3	4.0	V
Analog Supply Voltage Range	V _{DDA}		-0.3	4.0	V
ADC High Voltage Reference	V _{REFHX}		-0.3	4.0	V
Voltage difference V _{DD} to V _{DDA}	ΔV _{DD}		-0.3	0.3	V
Voltage difference V _{SS} to V _{SSA}	ΔV _{SS}		-0.3	0.3	V
Digital Input Voltage Range	V _{IN}	Pin Group 1	-0.3	5.5	V
RESET Input Voltage Range	V _{IN_RESET}	Pin Group 2	-0.3	4.0	V
Oscillator Input Voltage Range	V _{OSC}	Pin Group 4	-0.4	4.0	V
Analog Input Voltage Range	V _{INA}	Pin Group 3	-0.3	4.0	V
Input clamp current, per pin (V _{IN} < V _{SS} - 0.3 V) ^{2, 3}	V _{IC}		—	-5.0	mA
Output clamp current, per pin ⁴	V _{OC}		—	±20.0	mA
Contiguous pin DC injection current—regional limit sum of 16 contiguous pins	I _{ICont}		-25	25	mA
Output Voltage Range (normal push-pull mode)	V _{OUT}	Pin Group 1, 2	-0.3	4.0	V
Output Voltage Range (open drain mode)	V _{OUTOD}	Pin Group 1	-0.3	5.5	V
RESET Output Voltage Range	V _{OUTOD_RESET}	Pin Group 2	-0.3	4.0	V
DAC Output Voltage Range	V _{OUT_DAC}	Pin Group 5	-0.3	4.0	V
Ambient Temperature Industrial	T _A		-40	105	°C
Junction Temperature	T _j		-40	125	°C
Storage Temperature Range (Extended Industrial)	T _{STG}		-55	150	°C

1. Default Mode

- Pin Group 1: GPIO, TDI, TDO, TMS, TCK
- Pin Group 2: RESET

- Pin Group 3: ADC and Comparator Analog Inputs
 - Pin Group 4: XTAL, EXTAL
 - Pin Group 5: DAC analog output
2. Continuous clamp current
 3. All 5 volt tolerant digital I/O pins are internally clamped to V_{SS} through a ESD protection diode. There is no diode connection to V_{DD} . If V_{IN} greater than $VDIO_MIN (= V_{SS}-0.3\text{ V})$ is observed, then there is no need to provide current limiting resistors at the pads. If this limit cannot be observed, then a current limiting resistor is required.
 4. I/O is configured as push-pull mode.

8 General

8.1 General characteristics

The device is fabricated in high-density, low-power CMOS with 5 V–tolerant TTL-compatible digital inputs, except for the **RESET** pin which is 3.3V only. The term “5 V–tolerant” refers to the capability of an I/O pin, built on a 3.3 V–compatible process technology, to withstand a voltage up to 5.5 V without damaging the device.

5 V–tolerant I/O is desirable because many systems have a mixture of devices designed for 3.3 V and 5 V power supplies. In such systems, a bus may carry both 3.3 V– and 5 V–compatible I/O voltage levels (a standard 3.3 V I/O is designed to receive a maximum voltage of $3.3\text{ V} \pm 10\%$ during normal operation without causing damage). This 5 V–tolerant capability therefore offers the power savings of 3.3 V I/O levels combined with the ability to receive 5 V levels without damage.

Absolute maximum ratings in [Table 5](#) are stress ratings only, and functional operation at the maximum is not guaranteed. Stress beyond these ratings may affect device reliability or cause permanent damage to the device.

Unless otherwise stated, all specifications within this chapter apply over the temperature range of -40°C to 105°C ambient temperature over the following supply ranges:

$V_{SS}=V_{SSA}=0\text{V}$, $V_{DD}=V_{DDA}=3.0\text{V}$ to 3.6V , $CL \leq 50\text{ pF}$, $f_{OP}=60\text{MHz}$.

CAUTION

This device contains protective circuitry to guard against damage due to high static voltage or electrical fields. However, normal precautions are advised to avoid application of any voltages higher than maximum-rated voltages to this high-impedance circuit. Reliability of operation is enhanced if unused inputs are tied to an appropriate voltage level.

8.2 AC electrical characteristics

Tests are conducted using the input levels specified in Table 8. Unless otherwise specified, propagation delays are measured from the 50% to the 50% point, and rise and fall times are measured between the 10% and 90% points, as shown in Figure 3.

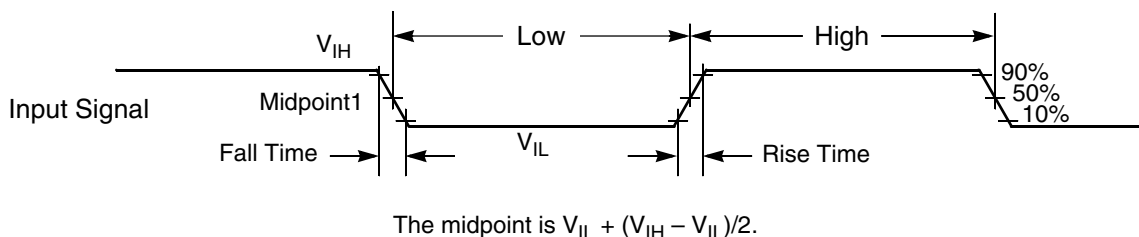

Figure 3. Input signal measurement references

Figure 4 shows the definitions of the following signal states:

- Active state, when a bus or signal is driven, and enters a low impedance state
- Tri-stated, when a bus or signal is placed in a high impedance state
- Data Valid state, when a signal level has reached V_{OL} or V_{OH}
- Data Invalid state, when a signal level is in transition between V_{OL} and V_{OH}

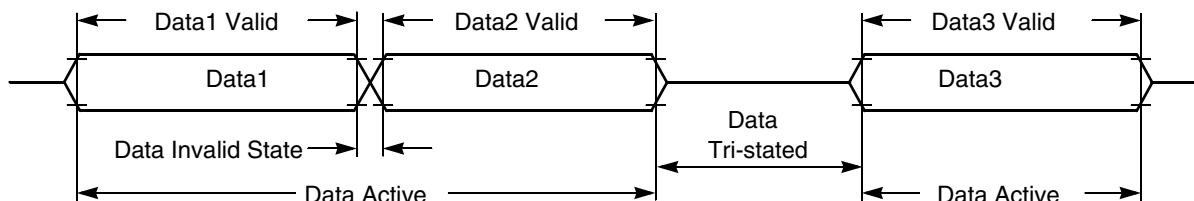

Figure 4. Signal states

8.3 Nonswitching electrical specifications

8.3.1 Voltage and current operating requirements

This section includes information about recommended operating conditions.

NOTE

Recommended V_{DD} ramp rate is between 1 ms and 200 ms.

Table 6. Recommended Operating Conditions ($V_{REFLX}=0V$, $V_{SSA}=0V$, $V_{SS}=0V$)

Characteristic	Symbol	Notes ¹	Min	Typ	Max	Unit
Supply voltage ²	V_{DD} , V_{DDA}		2.7	3.3	3.6	V

Table continues on the next page...

Table 6. Recommended Operating Conditions ($V_{REFLx}=0V$, $V_{SSA}=0V$, $V_{SS}=0V$) (continued)

Characteristic	Symbol	Notes ¹	Min	Typ	Max	Unit
ADC (Cyclic) Reference Voltage High	V_{REFHA} V_{REFHB}		3.0		V_{DDA}	V
ADC (SAR) Reference Voltage High	V_{REFHC}		2.0		V_{DDA}	V
Voltage difference V_{DD} to V_{DDA}	ΔV_{DD}		-0.1	0	0.1	V
Voltage difference V_{SS} to V_{SSA}	ΔV_{SS}		-0.1	0	0.1	V
Input Voltage High (digital inputs)	V_{IH}	Pin Group 1	$0.7 \times V_{DD}$		5.5	V
RESET Voltage High	V_{IH_RESET}	Pin Group 2	$0.7 \times V_{DD}$	—	V_{DD}	V
Input Voltage Low (digital inputs)	V_{IL}	Pin Groups 1, 2			$0.35 \times V_{DD}$	V
Oscillator Input Voltage High XTAL driven by an external clock source	V_{IHOSC}	Pin Group 4	2.0		$V_{DD} + 0.3$	V
Oscillator Input Voltage Low	V_{ILOSC}	Pin Group 4	-0.3		0.8	V
Output Source Current High (at V_{OH} min.) ^{3, 4} • Programmed for low drive strength • Programmed for high drive strength	I_{OH}	Pin Group 1 Pin Group 1	— —		-2 -9	mA
Output Source Current Low (at V_{OL} max.) ^{3, 4} • Programmed for low drive strength • Programmed for high drive strength	I_{OL}	Pin Groups 1, 2 Pin Groups 1, 2	— —		2 9	mA

1. Default Mode

- Pin Group 1: GPIO, TDI, TDO, TMS, TCK
- Pin Group 2: RESET
- Pin Group 3: ADC and Comparator Analog Inputs
- Pin Group 4: XTAL, EXTAL
- Pin Group 5: DAC analog output

2. ADC (Cyclic) specifications are not guaranteed when V_{DDA} is below 3.0 V.

3.

4. Contiguous pin DC injection current of regional limit—including sum of negative injection currents or sum of positive injection currents of 16 contiguous pins—is 25 mA.

8.3.2 LVD and POR operating requirements

Table 7. PMC Low-Voltage Detection (LVD) and Power-On Reset (POR) Parameters

Characteristic	Symbol	Min	Typ	Max	Unit
POR Assert Voltage ¹	POR		2.0		V
POR Release Voltage ²	POR		2.7		V
LVI_2p7 Threshold Voltage			2.73		V
LVI_2p2 Threshold Voltage			2.23		V

1. During 3.3-volt V_{DD} power supply ramp down

2. During 3.3-volt V_{DD} power supply ramp up (gated by LVI_2p7)

8.3.3 Voltage and current operating behaviors

The following table provides information about power supply requirements and I/O pin characteristics.

Table 8. DC Electrical Characteristics at Recommended Operating Conditions

Characteristic	Symbol	Notes ¹	Min	Typ	Max	Unit	Test Conditions
Output Voltage High	V _{OH}	Pin Group 1	V _{DD} - 0.5	—	—	V	I _{OH} = I _{OHmax}
Output Voltage Low	V _{OL}	Pin Groups 1, 2	—	—	0.5	V	I _{OL} = I _{OLmax}
Digital Input Current High pull-up enabled or disabled	I _{IH}	Pin Group 1	—	0	+/- 2.5	μA	V _{IN} = 2.4 V to 5.5 V
		Pin Group 2					V _{IN} = 2.4 V to V _{DD}
Comparator Input Current High	I _{IHC}	Pin Group 3	—	0	+/- 2	μA	V _{IN} = V _{DDA}
Oscillator Input Current High	I _{IHOSC}	Pin Group 3	—	0	+/- 2	μA	V _{IN} = V _{DDA}
Internal Pull-Up Resistance	R _{Pull-Up}		20	—	50	kΩ	—
Internal Pull-Down Resistance	R _{Pull-Down}		20	—	50	kΩ	—
Comparator Input Current Low	I _{ILC}	Pin Group 3	—	0	+/- 2	μA	V _{IN} = 0V
Oscillator Input Current Low	I _{ILOSC}	Pin Group 3	—	0	+/- 2	μA	V _{IN} = 0V
DAC Output Voltage Range	V _{DAC}	Pin Group 5	Typically V _{SSA} + 40mV	—	Typically V _{DDA} - 40mV	V	R _{LD} = 3 kΩ C _{LD} = 400 pF
Output Current ¹ High Impedance State	I _{OZ}	Pin Groups 1, 2	—	0	+/- 1	μA	—
Schmitt Trigger Input Hysteresis	V _{HYS}	Pin Groups 1, 2	0.06 x V _{DD}	—	—	V	—

1. Default Mode

- Pin Group 1: GPIO, TDI, TDO, TMS, TCK
- Pin Group 2: RESET
- Pin Group 3: ADC and Comparator Analog Inputs
- Pin Group 4: XTAL, EXTAL
- Pin Group 5: DAC

8.3.4 Power mode operating behaviors

Parameters listed are guaranteed by design.

NOTE

To filter noise on the RESETB pin, install a capacitor (up to 0.1 uF) on it.

Table 9. Reset, stop, wait, and interrupt timing

Characteristic	Symbol	Typical Min	Typical Max	Unit	See Figure
Minimum RESET Assertion Duration	t_{RA}	16 ¹	—	ns	—
RESET deassertion to First Address Fetch	t_{RDA}	$865 \times T_{OSC} + 8 \times T$		ns	—
Delay from Interrupt Assertion to Fetch of first instruction (exiting Stop)	t_{IF}	361.3	570.9	ns	—

1. If the RESET pin filter is enabled by setting the RST_FLT bit in the SIM_CTRL register to 1, the minimum pulse assertion must be greater than 21 ns.

NOTE

In the [Table 9](#), T = system clock cycle and T_{OSC} = oscillator clock cycle. For an operating frequency of 60MHz, T=16.6ns.
At 4MHz (used coming out of reset and stop modes), T=250ns.

Table 10. Power-On-Reset mode transition times

Symbol	Description	Min	Max	Unit	Notes
T_{POR}	After a POR event, the amount of delay from when VDD reaches 2.7V to when the first instruction executes (over the operating temperature range).	199	225	us	
	LPS mode to LPRUN mode	240	551	us	4
	VLPS mode to VLPRUN mode	1424	1500	us	5
	STOP mode to RUN mode	6.79	7.29	us	3
	WAIT mode to RUN mode	0.70	0.87	us	2
	VLPWAIT mode to VLPRUN mode	1413	1500	us	5
	LPWAIT mode to LPRUN mode	237.2	554	us	4

1. Normal boot (FTFL_OPT[LPBOOT]=1)
2. Clock configuration: CPU clock = 60 MHz, bus clock = 60 MHz, flash clock = 15 MHz
3. Clock configuration: CPU clock = 4 MHz, system clock source is 8 MHz IRC
4. CPU Clock = 200 kHz and 8 Mhz IRC in standby mode
5. Clock configuration: Using 64 kHz external clock source, CPU Clock = 32 kHz

8.3.5 Power consumption operating behaviors

Table 11. Current Consumption

Mode	Maximum Frequency	Conditions	Typical at 3.3 V, 25°C		Maximum at 3.6 V, 105°C	
			I _{DD} ¹	I _{DDA}	I _{DD} ¹	I _{DDA}
RUN	60 MHz	<ul style="list-style-type: none"> 60 MHz Device Clock Regulators are in full regulation Relaxation Oscillator on PLL powered on Continuous MAC instructions with fetches from Program Flash All peripheral modules enabled. TMRs and SCIs using 1X Clock NanoEdge within PWMA using 1X clock ADC/DAC powered on and clocked at 5 MHz² Comparator powered on 	31.4 mA	15.5 mA	55.2 mA	24.5 mA
WAIT	60 MHz	<ul style="list-style-type: none"> 60 MHz Device Clock Regulators are in full regulation Relaxation Oscillator on PLL powered on Processor Core in WAIT state All Peripheral modules enabled. TMRs and SCIs using 1X Clock NanoEdge within PWMA using 2X clock ADC/DAC/Comparator powered off 	28.2 mA	13.36 µA	50.1 mA	44.10 µA
STOP	4 MHz	<ul style="list-style-type: none"> 4 MHz Device Clock Regulators are in full regulation Relaxation Oscillator on PLL powered off Processor Core in STOP state All peripheral module and core clocks are off ADC/DAC/Comparator powered off 	8.99 mA	12.97 µA	28.13 mA	41.55 µA
LPRUN (LsRUN)	2 MHz	<ul style="list-style-type: none"> 200 kHz Device Clock from Relaxation Oscillator (ROSC) ROSC in standby mode Regulators are in standby PLL disabled Repeat NOP instructions All peripheral modules enabled, except NanoEdge and cyclic ADCs³ Simple loop with running from platform instruction buffer 	1.84 mA	3 mA	15.61 mA	4.87 mA
LPWAIT (LsWAIT)	2 MHz	<ul style="list-style-type: none"> 200 kHz Device Clock from Relaxation Oscillator (ROSC) ROSC in standby mode Regulators are in standby PLL disabled All peripheral modules enabled, except NanoEdge and cyclic ADCs³ Processor core in wait mode 	1.81 mA	2.67 mA	15.4 mA	4.87 mA

Table continues on the next page...

Table 11. Current Consumption (continued)

Mode	Maximum Frequency	Conditions	Typical at 3.3 V, 25°C		Maximum at 3.6 V, 105°C	
			I _{DD} ¹	I _{DDA}	I _{DD} ¹	I _{DDA}
LPSTOP (LsSTOP)	2 MHz	<ul style="list-style-type: none"> • 200 kHz Device Clock from Relaxation Oscillator (ROSC) • ROSC in standby mode • Regulators are in standby • PLL disabled • Only PITs and COP enabled; other peripheral modules disabled and clocks gated off³ • Processor core in stop mode 	1.06 mA	12.68 µA	14.49 mA	41.55 µA
VLPRUN	200 kHz	<ul style="list-style-type: none"> • 32 kHz Device Clock • Clocked by a 32 kHz external clock source • Oscillator in power down • All ROSCs disabled • Large regulator is in standby • Small regulator is disabled • PLL disabled • Repeat NOP instructions • All peripheral modules, except COP and EWM, disabled and clocks gated off • Simple loop running from platform instruction buffer 	0.57 mA	12.20 µA	8.14 mA	15.00 µA
VLPWAIT	200 kHz	<ul style="list-style-type: none"> • 32 kHz Device Clock • Clocked by a 32 kHz external clock source • Oscillator in power down • All ROSCs disabled • Large regulator is in standby • Small regulator is disabled • PLL disabled • All peripheral modules, except COP, disabled and clocks gated off • Processor core in wait mode 	0.56 mA	11.04 µA	8.13 mA	13.29 µA
VLPSTOP	200 kHz	<ul style="list-style-type: none"> • 32 kHz Device Clock • Clocked by a 32 kHz external clock source • Oscillator in power down • All ROSCs disabled • Large regulator is in standby • Small regulator is disabled • PLL disabled • All peripheral modules, except COP, disabled and clocks gated off • Processor core in stop mode 	0.56 mA	10.23 µA	12.10 mA	12.04 µA

1. No output switching, all ports configured as inputs, all inputs low, no DC loads
2. ADC power consumption at higher frequency can be found in [Table 28](#)
3. In all chip LP modes and flash memory VLP modes, the maximum frequency for flash memory operation is 250 kHz, because of the fixed frequency ratio of 1:4 between the CPU clock and the flash clock (when using a 2 MHz external input clock and the CPU is operating at 1 MHz).

8.3.6 Designing with radiated emissions in mind

To find application notes that provide guidance on designing your system to minimize interference from radiated emissions:

1. Go to www.freescale.com.
2. Perform a keyword search for “EMC design.”

8.3.7 Capacitance attributes

Table 12. Capacitance attributes

Description	Symbol	Min.	Typ.	Max.	Unit
Input capacitance	C _{IN}	—	10	—	pF
Output capacitance	C _{OUT}	—	10	—	pF

8.4 Switching specifications

8.4.1 Device clock specifications

Table 13. Device clock specifications

Symbol	Description	Min.	Max.	Unit	Notes
Normal run mode					
f _{SYSCLK}	Device (system and core) clock frequency <ul style="list-style-type: none"> • using relaxation oscillator • using external clock source 	0.001 0	60 60	MHz	
f _{IPBUS}	IP bus clock	—	60	MHz	

8.4.2 General switching timing

Table 14. Switching timing

Symbol	Description	Min	Max	Unit	Notes
	GPIO pin interrupt pulse width ¹ Synchronous path	1.5		IP Bus Clock Cycles	2
	Port rise and fall time (high drive strength), Slew disabled 2.7 ≤ V _{DD} ≤ 3.6V.	5.5	15.1	ns	3
	Port rise and fall time (high drive strength), Slew enabled 2.7 ≤ V _{DD} ≤ 3.6V.	1.5	6.8	ns	3

Table continues on the next page...

Table 14. Switching timing (continued)

Symbol	Description	Min	Max	Unit	Notes
	Port rise and fall time (low drive strength). Slew disabled . 2.7 $\leq V_{DD} \leq 3.6V$	8.2	17.8	ns	4
	Port rise and fall time (low drive strength). Slew enabled . 2.7 $\leq V_{DD} \leq 3.6V$	3.2	9.2	ns	4

1. Applies to a pin only when it is configured as GPIO and configured to cause an interrupt by appropriately programming GPIO_n_IPOLR and GPIO_n_IENR.
2. The greater synchronous and asynchronous timing must be met.
3. 75 pF load
4. 15 pF load

8.5 Thermal specifications

8.5.1 Thermal operating requirements

Table 15. Thermal operating requirements

Symbol	Description	Min.	Max.	Unit
T_J	Die junction temperature	-40		°C
T_A	Ambient temperature (extended industrial)	-40		°C

8.5.2 Thermal attributes

This section provides information about operating temperature range, power dissipation, and package thermal resistance. Power dissipation on I/O pins is usually small compared to the power dissipation in on-chip logic and voltage regulator circuits, and it is user-determined rather than being controlled by the MCU design. To account for $P_{I/O}$ in power calculations, determine the difference between actual pin voltage and V_{SS} or V_{DD} and multiply by the pin current for each I/O pin. Except in cases of unusually high pin current (heavy loads), the difference between pin voltage and V_{SS} or V_{DD} is very small.

See [Thermal design considerations](#) for more detail on thermal design considerations.

Board type	Symbol	Description	48 LQFP	64 LQFP	Unit	Notes
Single-layer (1s)	$R_{\theta JA}$	Thermal resistance, junction to ambient (natural convection)	70	64	°C/W	1, 2

Table continues on the next page...

Peripheral operating requirements and behaviors

Board type	Symbol	Description	48 LQFP	64 LQFP	Unit	Notes
Four-layer (2s2p)	$R_{\theta JA}$	Thermal resistance, junction to ambient (natural convection)	46	46	°C/W	1, 3
Single-layer (1s)	$R_{\theta JMA}$	Thermal resistance, junction to ambient (200 ft./min. air speed)	57	52	°C/W	1,3
Four-layer (2s2p)	$R_{\theta JMA}$	Thermal resistance, junction to ambient (200 ft./min. air speed)	39	39	°C/W	1,3
—	$R_{\theta JB}$	Thermal resistance, junction to board	23	28	°C/W	4
—	$R_{\theta JC}$	Thermal resistance, junction to case	17	15	°C/W	5
—	Ψ_{JT}	Thermal characterization parameter, junction to package top outside center (natural convection)	3	3	°C/W	6

1. Junction temperature is a function of die size, on-chip power dissipation, package thermal resistance, mounting site (board) temperature, ambient temperature, air flow, power dissipation of other components on the board, and board thermal resistance.
2. Determined according to JEDEC Standard JESD51-2, *Integrated Circuits Thermal Test Method Environmental Conditions—Natural Convection (Still Air)* with the single layer board horizontal. For the LQFP, the board meets the JESD51-3 specification.
3. Determined according to JEDEC Standard JESD51-6, *Integrated Circuits Thermal Test Method Environmental Conditions—Forced Convection (Moving Air)* with the board horizontal.
4. Determined according to JEDEC Standard JESD51-8, *Integrated Circuit Thermal Test Method Environmental Conditions—Junction-to-Board*. Board temperature is measured on the top surface of the board near the package.
5. Determined according to Method 1012.1 of MIL-STD 883, *Test Method Standard, Microcircuits*, with the cold plate temperature used for the case temperature. The value includes the thermal resistance of the interface material between the top of the package and the cold plate.
6. Determined according to JEDEC Standard JESD51-2, *Integrated Circuits Thermal Test Method Environmental Conditions—Natural Convection (Still Air)*.

9 Peripheral operating requirements and behaviors

9.1 Core modules

9.1.1 JTAG timing

Table 16. JTAG timing

Characteristic	Symbol	Min	Max	Unit	See Figure
TCK frequency of operation	f_{OP}	DC	SYS_CLK/ 16	MHz	Figure 5
TCK clock pulse width	t_{PW}	50	—	ns	Figure 5
TMS, TDI data set-up time	t_{DS}	5	—	ns	Figure 6
TMS, TDI data hold time	t_{DH}	5	—	ns	Figure 6
TCK low to TDO data valid	t_{DV}	—	30	ns	Figure 6
TCK low to TDO tri-state	t_{TS}	—	30	ns	Figure 6

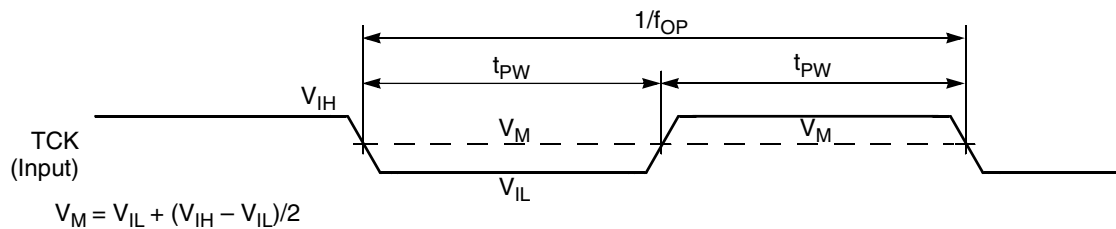
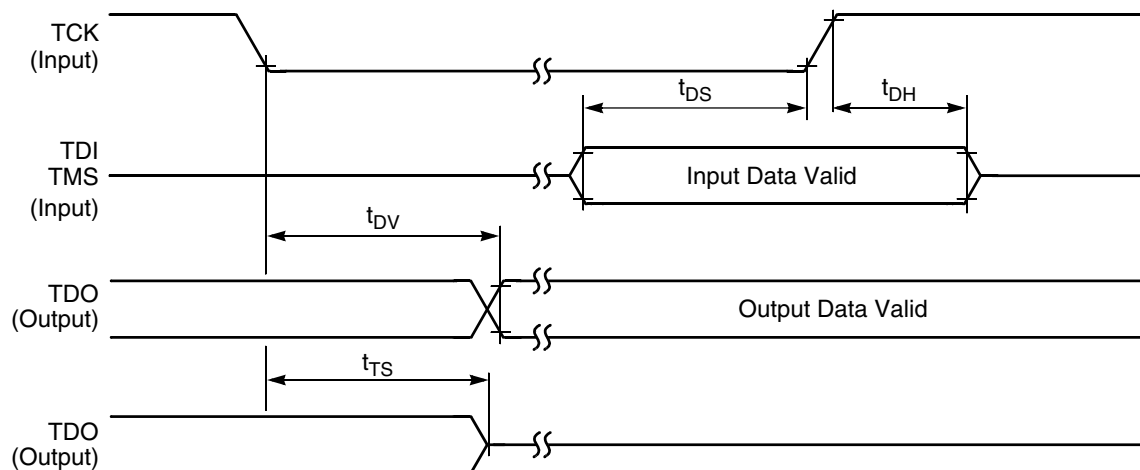
Figure 5. Test clock input timing diagram

Figure 6. Test access port timing diagram

9.2 System modules

9.2.1 Voltage regulator specifications

The voltage regulator supplies approximately 1.2 V to the MC56F84xxx's core logic. For proper operations, the voltage regulator requires an external 2.2 μF capacitor on each V_{CAP} pin. Ceramic and tantalum capacitors tend to provide better performance tolerances. The output voltage can be measured directly on the V_{CAP} pin. The specifications for this regulator are shown in [Table 17](#).

Table 17. Regulator 1.2 V parameters

Characteristic	Symbol	Min	Typ	Max	Unit
Output Voltage ¹	V_{CAP}	—	1.22	—	V
Short Circuit Current ²	I_{SS}	—	600	—	mA
Short Circuit Tolerance (V_{CAP} shorted to ground)	T_{RSC}	—	—	30	Minutes

1. Value is after trim
2. Guaranteed by design

Table 18. Bandgap electrical specifications

Characteristic	Symbol	Min	Typ	Max	Unit
Reference Voltage (after trim)	V_{REF}	—	1.21	—	V

9.3 Clock modules

9.3.1 External clock operation timing

Parameters listed are guaranteed by design.

Table 19. External clock operation timing requirements

Characteristic	Symbol	Min	Typ	Max	Unit
Frequency of operation (external clock driver) ¹	f_{osc}	—	—	50	MHz
Clock pulse width ²	t_{PW}	8			ns
External clock input rise time ³	t_{rise}	—	—	1	ns
External clock input fall time ⁴	t_{fall}	—	—	1	ns
Input high voltage overdrive by an external clock	V_{ih}	$0.85V_{\text{DD}}$	—	—	V
Input low voltage overdrive by an external clock	V_{il}	—	—	$0.3V_{\text{DD}}$	V

1. See [Figure 7](#) for detail on using the recommended connection of an external clock driver.
2. The chip may not function if the high or low pulse width is smaller than 6.25 ns.
3. External clock input rise time is measured from 10% to 90%.
4. External clock input fall time is measured from 90% to 10%.

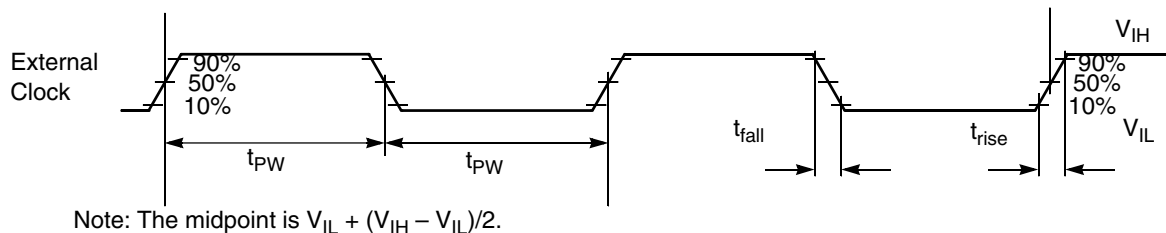
Figure 7. External clock timing

9.3.2 Phase-Locked Loop timing

Table 20. Phase-Locked Loop timing

Characteristic	Symbol	Min	Typ	Max	Unit
PLL input reference frequency ¹	f_{ref}	8	8	16	MHz
PLL output frequency ²	f_{op}		—	400	MHz
PLL lock time ³	t_{plls}	35.5		73.2	μ s
Allowed Duty Cycle of input reference	t_{dc}	40	50	60	%

1. An externally supplied reference clock should be as free as possible from any phase jitter for the PLL to work correctly. The PLL is optimized for 8 MHz input.
2. The frequency of the core system clock cannot exceed 60 MHz.
3. This is the time required *after the PLL is enabled* to ensure reliable operation.

9.3.3 External crystal or resonator requirement

Table 21. Crystal or resonator requirement

Characteristic	Symbol	Min	Typ	Max	Unit
Frequency of operation	f_{XOSC}	4	8	16	MHz

9.3.4 Relaxation oscillator timing

Table 22. Relaxation oscillator electrical specifications

Characteristic	Symbol	Min	Typ	Max	Unit
8 MHz Output Frequency ¹		7.84	8	8.16	MHz
RUN Mode		7.76	8	8.24	kHz
<ul style="list-style-type: none"> • 0°C to 105°C • -40°C to 105°C 		266.8	402	554.3	
Standby Mode (IRC trimmed @ 8 MHz)					
<ul style="list-style-type: none"> • -40°C to 105°C 					
8 MHz Frequency Variation					
RUN Mode			+/- 1.5	+/-2	%
Due to temperature <ul style="list-style-type: none"> • 0°C to 105°C • -40°C to 105°C 			+/- 1.5	+/-3	
32 kHz Output Frequency ²		30.1	32	33.9	kHz
RUN Mode					%
<ul style="list-style-type: none"> • -40°C to 105°C 					
32 kHz Output Frequency Variation					
RUN Mode			+/-2.5	+/-4	%
Due to temperature <ul style="list-style-type: none"> • -40°C to 105°C 					
Stabilization Time	tstab		0.12	0.4	μs
<ul style="list-style-type: none"> • 8 MHz output³ • 32 kHz output⁴ 			14.4	16.2	
Output Duty Cycle		48	50	52	%

1. Frequency after application of 8 MHz trim
2. Frequency after application of 32 kHz trim
3. Standby to run mode transition
4. Power down to run mode transition

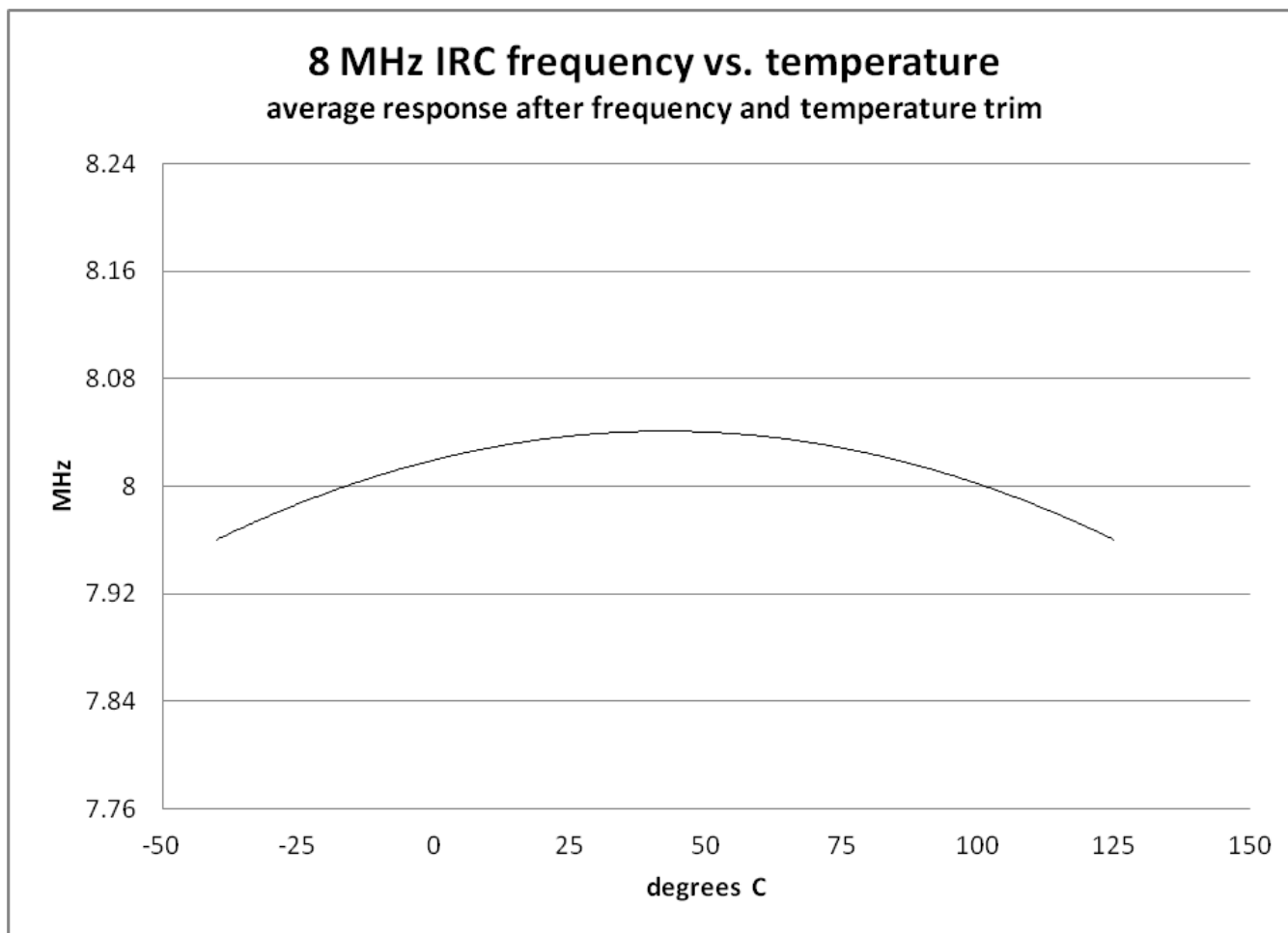

Figure 8. Relaxation oscillator temperature variation (typical) after trim (preliminary)

9.4 Memories and memory interfaces

9.4.1 Flash electrical specifications

This section describes the electrical characteristics of the flash memory module.

9.4.1.1 Flash timing specifications — program and erase

The following specifications represent the amount of time the internal charge pumps are active and do not include command overhead.

Table 23. NVM program/erase timing specifications

Symbol	Description	Min.	Typ.	Max.	Unit	Notes
t_{hvpgm4}	Longword Program high-voltage time	—	7.5	18	μ s	—

Table continues on the next page...

Table 23. NVM program/erase timing specifications (continued)

Symbol	Description	Min.	Typ.	Max.	Unit	Notes
$t_{hversscr}$	Sector Erase high-voltage time	—	13	113	ms	1
$t_{hversblk32k}$	Erase Block high-voltage time for 32 KB	—	52	452	ms	1
$t_{hversblk256k}$	Erase Block high-voltage time for 256 KB	—	104	904	ms	1

1. Maximum time based on expectations at cycling end-of-life.

9.4.1.2 Flash timing specifications — commands

Table 24. Flash command timing specifications

Symbol	Description	Min.	Typ.	Max.	Unit	Notes
$t_{rd1blk32k}$	Read 1s Block execution time • 32 KB data flash	—	—	0.5	ms	—
$t_{rd1blk256k}$	• 256 KB program flash	—	—	1.7	ms	—
$t_{rd1sec1k}$	Read 1s Section execution time (data flash sector)	—	—	60	μ s	1
$t_{rd1sec2k}$	Read 1s Section execution time (program flash sector)	—	—	60	μ s	1
t_{pgmchk}	Program Check execution time	—	—	45	μ s	1
t_{rdsrc}	Read Resource execution time	—	—	30	μ s	1
t_{pgm4}	Program Longword execution time	—	65	145	μ s	—
$t_{ersblk32k}$	Erase Flash Block execution time • 32 KB data flash	—	55	465	ms	2
$t_{ersblk256k}$	• 256 KB program flash	—	122	985	ms	2
t_{ersscr}	Erase Flash Sector execution time	—	14	114	ms	2
$t_{pgmsec512p}$	Program Section execution time • 512 B program flash	—	2.4	—	ms	—
$t_{pgmsec512d}$	• 512 B data flash	—	4.7	—	ms	—
$t_{pgmsec1kp}$	• 1 KB program flash	—	4.7	—	ms	—
$t_{pgmsec1kd}$	• 1 KB data flash	—	9.3	—	ms	—
t_{rd1all}	Read 1s All Blocks execution time	—	—	1.8	ms	—
t_{rdonce}	Read Once execution time	—	—	25	μ s	1
$t_{pgmonce}$	Program Once execution time	—	65	—	μ s	—
t_{ersall}	Erase All Blocks execution time	—	175	1500	ms	2
t_{vfykey}	Verify Backdoor Access Key execution time	—	—	30	μ s	1
$t_{pgmpart32k}$	Program Partition for EEPROM execution time • 32 KB FlexNVM	—	70	—	ms	—

Table continues on the next page...

Table 24. Flash command timing specifications (continued)

Symbol	Description	Min.	Typ.	Max.	Unit	Notes
t_{setramff}	Set FlexRAM Function execution time:					—
	• Control Code 0xFF	—	50	—	μs	
t_{setram8k}	• 8 KB EEPROM backup	—	0.3	0.5	ms	
$t_{\text{setram32k}}$	• 32 KB EEPROM backup	—	0.7	1.0	ms	
Byte-write to FlexRAM for EEPROM operation						
$t_{\text{eewr8bers}}$	Byte-write to erased FlexRAM location execution time	—	175	260	μs	3
t_{eewr8b8k}	Byte-write to FlexRAM execution time:					—
	• 8 KB EEPROM backup	—	340	1700	μs	
$t_{\text{eewr8b16k}}$	• 16 KB EEPROM backup	—	385	1800	μs	
$t_{\text{eewr8b32k}}$	• 32 KB EEPROM backup	—	475	2000	μs	
Word-write to FlexRAM for EEPROM operation						
$t_{\text{eewr16bers}}$	Word-write to erased FlexRAM location execution time	—	175	260	μs	—
$t_{\text{eewr16b8k}}$	Word-write to FlexRAM execution time:					—
	• 8 KB EEPROM backup	—	340	1700	μs	
$t_{\text{eewr16b16k}}$	• 16 KB EEPROM backup	—	385	1800	μs	
$t_{\text{eewr16b32k}}$	• 32 KB EEPROM backup	—	475	2000	μs	
Longword-write to FlexRAM for EEPROM operation						
$t_{\text{eewr32bers}}$	Longword-write to erased FlexRAM location execution time	—	360	540	μs	—
$t_{\text{eewr32b8k}}$	Longword-write to FlexRAM execution time:					—
	• 8 KB EEPROM backup	—	545	1950	μs	
$t_{\text{eewr32b16k}}$	• 16 KB EEPROM backup	—	630	2050	μs	
$t_{\text{eewr32b32k}}$	• 32 KB EEPROM backup	—	810	2250	μs	

1. Assumes 25 MHz flash clock frequency.
2. Maximum times for erase parameters based on expectations at cycling end-of-life.
3. For byte-writes to an erased FlexRAM location, the aligned word containing the byte must be erased.

9.4.1.3 Flash high voltage current behaviors

Table 25. Flash high voltage current behaviors

Symbol	Description	Min.	Typ.	Max.	Unit
$I_{\text{DD_PGM}}$	Average current adder during high voltage flash programming operation	—	2.5	6.0	mA
$I_{\text{DD_ERS}}$	Average current adder during high voltage flash erase operation	—	1.5	4.0	mA

9.4.1.4 Reliability specifications

Table 26. NVM reliability specifications

Symbol	Description	Min.	Typ. ¹	Max.	Unit	Notes
Program Flash						
$t_{nvmretp10k}$	Data retention after up to 10 K cycles	5	50	—	years	—
$t_{nvmretp1k}$	Data retention after up to 1 K cycles	20	100	—	years	—
$n_{nvmcycp}$	Cycling endurance	10 K	50 K	—	cycles	2
Data Flash						
$t_{nvmretd10k}$	Data retention after up to 10 K cycles	5	50	—	years	—
$t_{nvmretd1k}$	Data retention after up to 1 K cycles	20	100	—	years	—
$n_{nvmcycd}$	Cycling endurance	10 K	50 K	—	cycles	2
FlexRAM as EEPROM						
$t_{nvmretee100}$	Data retention up to 100% of write endurance	5	50	—	years	—
$t_{nvmretee10}$	Data retention up to 10% of write endurance	20	100	—	years	—
	Write endurance					3
$n_{nvmwree16}$	• EEPROM backup to FlexRAM ratio = 16	35 K	175 K	—	writes	
$n_{nvmwree128}$	• EEPROM backup to FlexRAM ratio = 128	315 K	1.6 M	—	writes	
$n_{nvmwree512}$	• EEPROM backup to FlexRAM ratio = 512	1.27 M	6.4 M	—	writes	
$n_{nvmwree4k}$	• EEPROM backup to FlexRAM ratio = 4096	10 M	50 M	—	writes	
$n_{nvmwree8k}$	• EEPROM backup to FlexRAM ratio = 8192	20 M	100 M	—	writes	

1. Typical data retention values are based on measured response accelerated at high temperature and derated to a constant 25 °C use profile. Engineering Bulletin EB618 does not apply to this technology. Typical endurance defined in Engineering Bulletin EB619.
2. Cycling endurance represents number of program/erase cycles at $-40\text{ °C} \leq T_j \leq 125\text{ °C}$.
3. Write endurance represents the number of writes to each FlexRAM location at $-40\text{ °C} \leq T_j \leq 125\text{ °C}$ influenced by the cycling endurance of the FlexNVM (same value as data flash) and the allocated EEPROM backup. Minimum and typical values assume all byte-writes to FlexRAM.

9.5 Analog

9.5.1 12-bit cyclic Analog-to-Digital Converter (ADC) parameters

Table 27. 12-bit ADC electrical specifications

Characteristic	Symbol	Min	Typ	Max	Unit
Recommended Operating Conditions					
Supply Voltage ¹	V_{DDA}	2.7	3.3	3.6	V
Vrefh Supply Voltage ²	V_{refhx}	3.0		V_{DDA}	V
ADC Conversion Clock ³	f_{ADCCLK}	0.6		10	MHz
Conversion Range	R_{AD}	V_{REFL}		V_{REFH}	V

Table continues on the next page...

Table 27. 12-bit ADC electrical specifications (continued)

Characteristic	Symbol	Min	Typ	Max	Unit
Input Voltage Range	V_{ADIN}	V_{REFL}		V_{REFH}	V
External Reference		V_{SSA}		V_{DDA}	
Internal Reference					
Timing and Power					
Conversion Time	t_{ADC}		6		ADC Clock Cycles
Sample Time	t_{ADS}	1		5	ADC Clock Cycles
ADC Power-Up Time (from adc_pdn)	t_{ADPU}		13		ADC Clock Cycles
ADC RUN Current (per ADC block)	I_{ADRUN}		1		mA
• at 600 kHz ADC Clock, LP mode			5.7		
• \leq 8.33 MHz ADC Clock, 00 mode			10.5		
• \leq 12.5 MHz ADC Clock, 01 mode			17.7		
• \leq 16.67 MHz ADC Clock, 10 mode			22.6		
• \leq 20 MHz ADC Clock, 11 mode					
ADC Powerdown Current (adc_pdn enabled)	$I_{ADPWRDWN}$		0.02		μ A
V_{REFH} Current	I_{VREFH}		0.001		μ A
Accuracy (DC or Absolute)					
Integral non-Linearity ⁴	I_{NL}		+/- 3	+/- 5	LSB ⁵
Differential non-Linearity ⁴	DNL		+/- 0.6	+/- 0.9	LSB ⁵
Monotonicity					
Offset	V_{OFFSET}				LSB ⁴
Gain Error (normalized)	E_{GAIN}		0.994 to 1.004	0.990 to 1.010	
AC Specifications⁶					
Signal to Noise Ratio	SNR		59		dB
Total Harmonic Distortion	THD		64		dB
Spurious Free Dynamic Range	SFDR		65		dB
Signal to Noise plus Distortion	SINAD		59		dB
Effective Number of Bits	ENOB				bits
ADC Inputs					
Input Leakage Current	I_{IN}		0	+/-2	μ A
Input Injection Current ⁷	I_{INJ}			+/-3	mA
Input Capacitance	C_{ADI}		-		μ F
Sampling Capacitor			-		
• 1x mode			1.4		
• 2x mode			2.8		
• 4x mode		5.6			

1. If the ADC's reference is from V_{DDA} : When V_{DDA} is below 3.0 V, then the ADC functions, but the ADC specifications are not guaranteed.

System modules

- When the input is at the V_{refl} level, then the resulting output will be all zeros (hex 000), plus any error contribution due to offset and gain error. When the input is at the V_{refh} level, then the output will be all ones (hex FFF), minus any error contribution due to offset and gain error.
- ADC clock duty cycle min/max is 45/55%
- I_{NL} measured from $V_{IN} = V_{REFL}$ to $V_{IN} = V_{REFH}$
- LSB = Least Significant Bit = 0.806 mV at 3.3 V VDDA, x1 Gain Setting
- Measured when converting a 1 kHz input Full Scale sine wave.
- The current that can be *injected into or sourced from* an unselected ADC input, without affecting the performance of the ADC.

9.5.1.1 Equivalent circuit for ADC inputs

The following figure shows the ADC input circuit during sample and hold. S1 and S2 are always opened/closed at non-overlapping phases, and both S1 and S2 operate at the ADC clock frequency. The following equation gives equivalent input impedance when the input is selected.

$$\frac{1}{(\text{ADC ClockRate}) \times 1.4 \times 10^{12}} + 100\text{ohm} + 125\text{ohm}$$

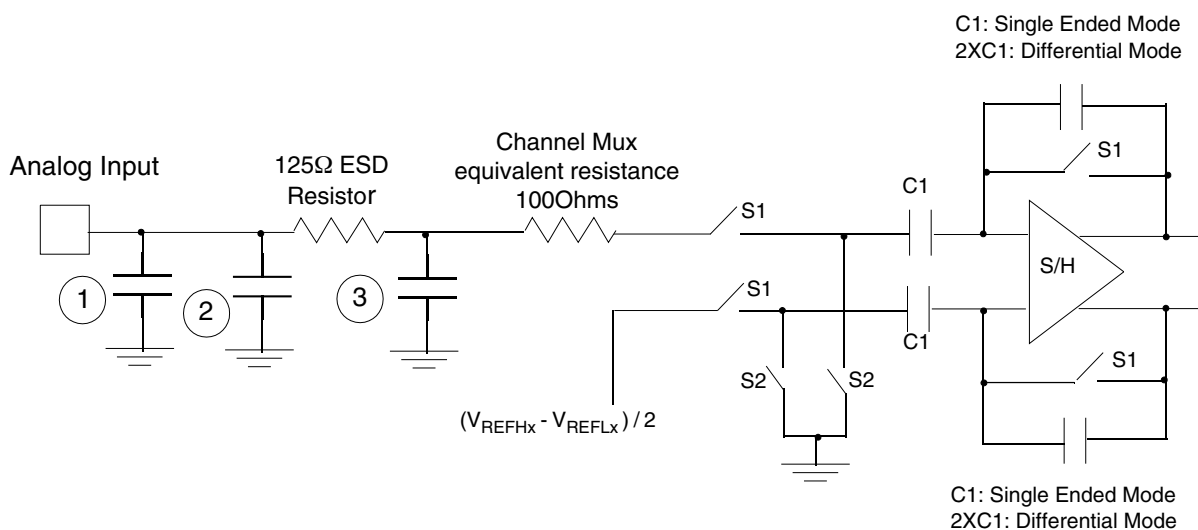

- Parasitic capacitance due to package, pin-to-pin and pin-to-package base coupling = 1.8pF
- Parasitic capacitance due to the chip bond pad, ESD protection devices and signal routing = 2.04pF
- 8 pF noise damping capacitor
- Sampling capacitor at the sample and hold circuit. Capacitor C1 (4.8pF) is normally disconnected from the input, and is only connected to the input at sampling time.
- S1 and S2 switch phases are non-overlapping and operate at the ADC clock frequency

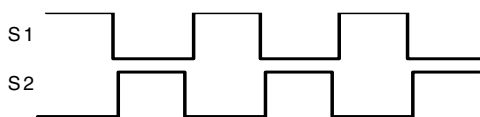

Figure 9. Equivalent circuit for A/D loading

9.5.2 16-bit SAR ADC electrical specifications

9.5.2.1 16-bit ADC operating conditions

Table 28. 16-bit ADC operating conditions

Symbol	Description	Conditions	Min.	Typ. ¹	Max.	Unit	Notes
V_{DDA}	Supply voltage	Absolute	2.7	—	3.6	V	—
ΔV_{DDA}	Supply voltage	Delta to V_{DD} ($V_{DD} - V_{DDA}$)	-100	0	+100	mV	2
ΔV_{SSA}	Ground voltage	Delta to V_{SS} ($V_{SS} - V_{SSA}$)	-100	0	+100	mV	2
V_{REFH}	ADC reference voltage high	Absolute	V_{DDA}	V_{DDA}	V_{DDA}	V	3
V_{REFL}	ADC reference voltage low	Absolute	V_{SSA}	V_{SSA}	V_{SSA}	V	4
V_{ADIN}	Input voltage		V_{SSA}	—	V_{DDA}	V	—
C_{ADIN}	Input capacitance	<ul style="list-style-type: none"> 16-bit mode 8-bit / 10-bit / 12-bit modes 	—	8	10	pF	—
R_{ADIN}	Input series resistance		—	2	5	k Ω	—
R_{AS}	Analog source resistance (external)	12-bit modes $f_{ADCK} < 4$ MHz	—	—	5	k Ω	5
f_{ADCK}	ADC conversion clock frequency	\leq 12-bit mode	1.0	—	18.0	MHz	6
f_{ADCK}	ADC conversion clock frequency	16-bit mode	2.0	—	12.0	MHz	6
C_{rate}	ADC conversion rate	\leq 12-bit modes No ADC hardware averaging Continuous conversions enabled, subsequent conversion time	20.000	—	818.330	Ksps	7
C_{rate}	ADC conversion rate	16-bit mode No ADC hardware averaging Continuous conversions enabled, subsequent conversion time	37.037	—	461.467	Ksps	7

1. Typical values assume $V_{DDA} = 3.0$ V, Temp = 25 °C, $f_{ADCK} = 1.0$ MHz, unless otherwise stated. Typical values are for reference only, and are not tested in production.
2. DC potential difference.

System modules

3. V_{REFH} is internally tied to V_{DDA} .
4. V_{REFL} is internally tied to V_{SSA} .
5. This resistance is external to MCU. To achieve the best results, the analog source resistance must be kept as low as possible. The results in this data sheet were derived from a system that had $< 8 \Omega$ analog source resistance. The R_{AS}/C_{AS} time constant should be kept to < 1 ns.
6. To use the maximum ADC conversion clock frequency, $CFG2[ADHSC]$ must be set and $CFG1[ADLPC]$ must be clear.
7. For guidelines and examples of conversion rate calculation, download the [ADC calculator tool](#).

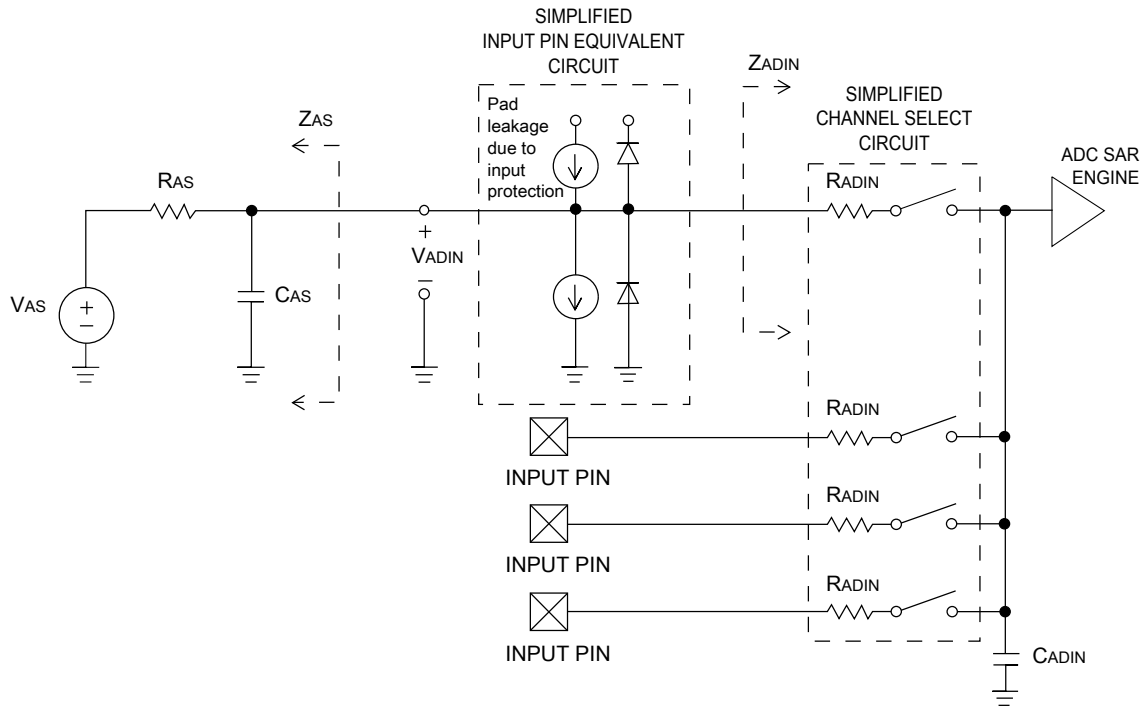

Figure 10. ADC input impedance equivalency diagram

9.5.2.2 16-bit ADC electrical characteristics

Table 29. 16-bit ADC characteristics ($V_{REFH} = V_{DDA}$, $V_{REFL} = V_{SSA}$)

Symbol	Description	Conditions ¹	Min.	Typ. ²	Max.	Unit	Notes
I_{DDA_ADC}	Supply current			—	1.7	mA	3
f_{ADACK}	ADC asynchronous clock source	• ADLPC=1, ADHSC=0	1.2	2.4	3.9	MHz	$t_{ADACK} = 1/f_{ADACK}$
		• ADLPC=1, ADHSC=1	3.0	4.0	7.3	MHz	
		• ADLPC=0, ADHSC=0	2.4	5.2	6.1	MHz	
		• ADLPC=0, ADHSC=1	4.4	6.2	9.5	MHz	
	Sample Time	See Reference Manual chapter for sample times					
TUE	Total unadjusted error	• 12-bit modes • <12-bit modes	—	± 4 ± 1.4	± 6.8 ± 2.1	LSB ⁴	5
DNL	Differential non-linearity	• 16-bit modes	—	-1 to +4	—	LSB ⁴	5
		• 12-bit modes	—	± 0.7	—		
		• <12-bit modes	—	± 0.2	-0.3 to 0.5		

Table continues on the next page...

Table 29. 16-bit ADC characteristics ($V_{REFH} = V_{DDA}$, $V_{REFL} = V_{SSA}$) (continued)

Symbol	Description	Conditions ¹	Min.	Typ. ²	Max.	Unit	Notes	
INL	Integral non-linearity	<ul style="list-style-type: none"> 16-bit modes 12-bit modes <12-bit modes 	—	±7.0	—	LSB ⁴	5	
E _{FS}	Full-scale error	<ul style="list-style-type: none"> 12-bit modes <12-bit modes 	—	-4	-5.4	LSB ⁴	V _{ADIN} = V _{DDA} 5	
E _Q	Quantization error	<ul style="list-style-type: none"> 16-bit modes 12-bit modes 	—	-1 to 0	—	LSB ⁴		
ENOB	Effective number of bits	16-bit single-ended mode					6	
		<ul style="list-style-type: none"> Avg=32 Avg=4 	12.2	13.9	—	bits		
		12-bit single-ended mode						
		<ul style="list-style-type: none"> Avg=32 Avg=1 	11.4	13.1	—	bits		
SINAD	Signal-to-noise plus distortion	See ENOB	6.02 × ENOB + 1.76			dB		
THD	Total harmonic distortion	16-bit single-ended mode					7	
		<ul style="list-style-type: none"> Avg=32 	—	-85	—	dB		
SFDR	Spurious free dynamic range	16-bit single-ended mode					7	
		<ul style="list-style-type: none"> Avg=32 	78	90	—	dB		
E _{IL}	Input leakage error	12-bit single-ended mode						
		<ul style="list-style-type: none"> Avg=32 	—	-74	—	dB		
			I _{in} × R _{AS}			mV	I _{in} = leakage current (refer to the device's voltage and current operating ratings)	
	Temp sensor slope	-40°C to 105°C	—	1.715	—	mV/°C		
V _{TEMP25}	Temp sensor voltage	25°C	—	722	—	mV	8	

 1. All accuracy numbers assume the ADC is calibrated with $V_{REFH} = V_{DDA}$

System modules

- Typical values assume $V_{DDA} = 3.0\text{ V}$, $\text{Temp} = 25^\circ\text{C}$, $f_{\text{ADCK}} = 2.0\text{ MHz}$, unless otherwise stated. Typical values are for reference only, and are not tested in production.
- The ADC supply current depends on the ADC conversion clock speed, conversion rate and the ADLPC bit (low power). For lowest power operations: the ADLPC bit should be set, the HSC bit should be clear, with 1MHz ADC conversion clock speed.
- $1\text{ LSB} = (V_{\text{REFH}} - V_{\text{REFL}})/2^N$
- ADC conversion clock $< 16\text{MHz}$, Max hardware averaging ($\text{AVGE} = \%1$, $\text{AVGS} = \%11$)
- Input data is 100 Hz sine wave. ADC conversion clock $< 12\text{MHz}$. When running 12-bit Cyclic ADC and 12-bit DAC, some degradation of ENOB (of 16-bit SAR ADC) may occur.
- Input data is 1 kHz sine wave. ADC conversion clock $< 12\text{MHz}$.
- System Clock = 4 MHz, ADC Clock = 2 MHz, AVG = Max, Long Sampling = Max

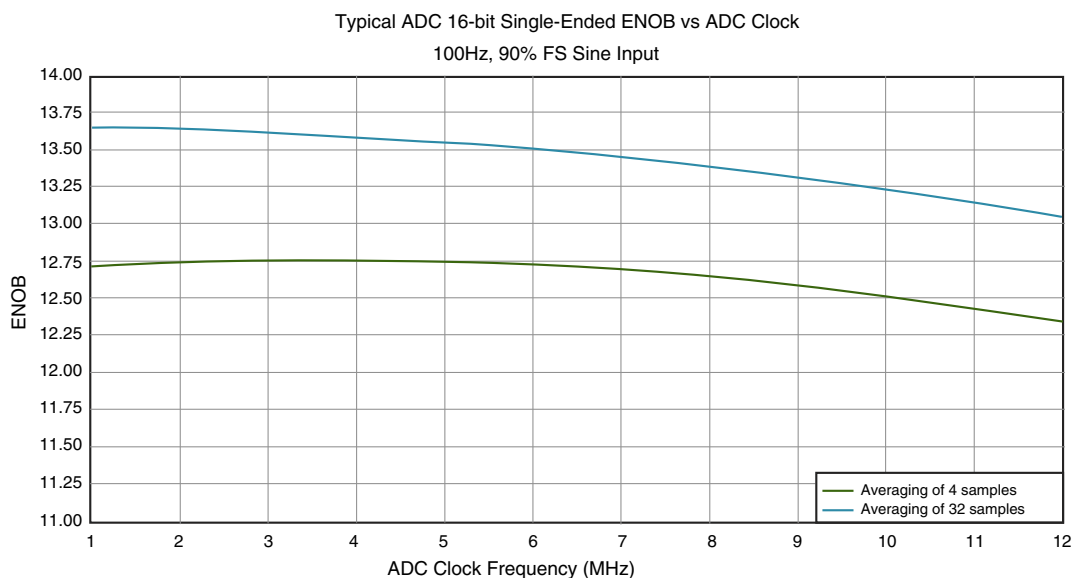

Figure 11. Typical ENOB vs. ADC_CLK for 16-bit single-ended mode

9.5.3 12-bit Digital-to-Analog Converter (DAC) parameters

Table 30. DAC parameters

Parameter	Conditions/Comments	Symbol	Min	Typ	Max	Unit
DC Specifications						
Resolution			12	12	12	bits
Settling time ¹	At output load RLD = 3 kΩ CLD = 400 pF		—	1		μs
Power-up time	Time from release of PWRDWN signal until DACOUT signal is valid	t_{DAPU}	—	—	11	μs
Accuracy						
Integral non-linearity ²	Range of input digital words: 410 to 3891 (\$19A - \$F33)	INL	—	+/- 3	+/- 4	LSB ³

Table continues on the next page...

Table 30. DAC parameters (continued)

Parameter	Conditions/Comments	Symbol	Min	Typ	Max	Unit
Differential non-linearity ²	Range of input digital words: 410 to 3891 (\$19A - \$F33)	DNL	—	+/- 0.8	+/- 0.9	LSB ³
Monotonicity	> 6 sigma monotonicity, < 3.4 ppm non-monotonicity		guaranteed			—
Offset error ²	Range of input digital words: 410 to 3891 (\$19A - \$F33)	V _{OFFSET}	—	+/- 25	+/- 43	mV
Gain error ²	Range of input digital words: 410 to 3891 (\$19A - \$F33)	E _{GAIN}	—	+/- 0.5	+/- 1.5	%
DAC Output						
Output voltage range	Within 40 mV of either V _{SSA} or V _{DDA}	V _{OUT}	V _{SSA} + 0.04 V	—	V _{DDA} - 0.04 V	V
AC Specifications						
Signal-to-noise ratio		SNR	—	85	—	dB
Spurious free dynamic range		SFDR	—	-72	—	dB
Effective number of bits		ENOB	—	11	—	bits

1. Settling time is swing range from V_{SSA} to V_{DDA}
2. No guaranteed specification within 5% of V_{DDA} or V_{SSA}
3. LSB = 0.806 mV

9.5.4 CMP and 6-bit DAC electrical specifications

Table 31. Comparator and 6-bit DAC electrical specifications

Symbol	Description	Min.	Typ.	Max.	Unit
V _{DD}	Supply voltage	2.7	—	3.6	V
I _{DDHS}	Supply current, high-speed mode (EN=1, PMODE=1)	—	—	200	μA
I _{DDL}	Supply current, low-speed mode (EN=1, PMODE=0)	—	—	20	μA
V _{AIN}	Analog input voltage	V _{SS} - 0.3	—	V _{DD}	V
V _{AIO}	Analog input offset voltage	—	—	20	mV
V _H	Analog comparator hysteresis ¹ <ul style="list-style-type: none"> • CR0[HYSTCTR] = 00 • CR0[HYSTCTR] = 01 • CR0[HYSTCTR] = 10 • CR0[HYSTCTR] = 11 	—	5 10 20 30	13 48 105 148	mV mV mV mV
V _{CMPOH}	Output high	V _{DD} - 0.5	—	—	V
V _{CMPOI}	Output low	—	—	0.5	V
t _{DHS}	Propagation delay, high-speed mode (EN=1, PMODE=1) ²		50		ns

Table continues on the next page...

Table 31. Comparator and 6-bit DAC electrical specifications (continued)

Symbol	Description	Min.	Typ.	Max.	Unit
t_{DLS}	Propagation delay, low-speed mode (EN=1, PMODE=0)		250		ns
	Analog comparator initialization delay ³	—	—	40	μ s
I_{DAC6b}	6-bit DAC current adder (enabled)	—	7	—	μ A
	6-bit DAC reference inputs: Vin1, Vin2 There are two reference input options selectable (via VRSEL control bit). The reference options must fall within this range.	V_{DDA}	—	V_{DD}	V
INL	6-bit DAC integral non-linearity	-0.5	—	0.5	LSB ⁴
DNL	6-bit DAC differential non-linearity	-0.3	—	0.3	LSB

1. Typical hysteresis is measured with input voltage range limited to 0.6 to $V_{DD}-0.6V$.
2. Signal swing is 100 mV
3. Comparator initialization delay is defined as the time between software writes (to DACEN, VRSEL, PSEL, MSEL, VOSEL), to change the control inputs and for the comparator output to settle to a stable level.
4. 1 LSB = $V_{reference}/64$

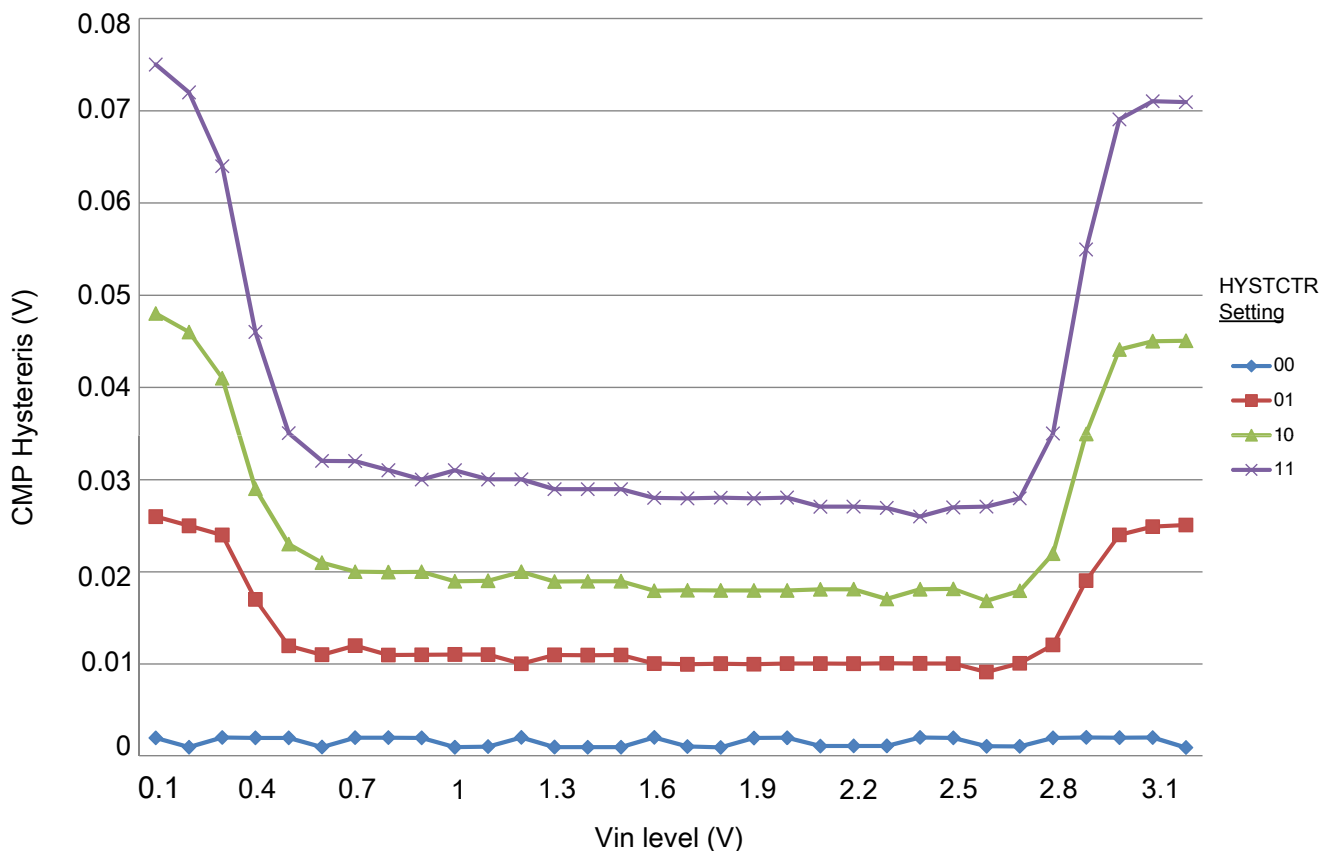

Figure 12. Typical hysteresis vs. Vin level ($V_{DD} = 3.3 V$, PMODE = 0)

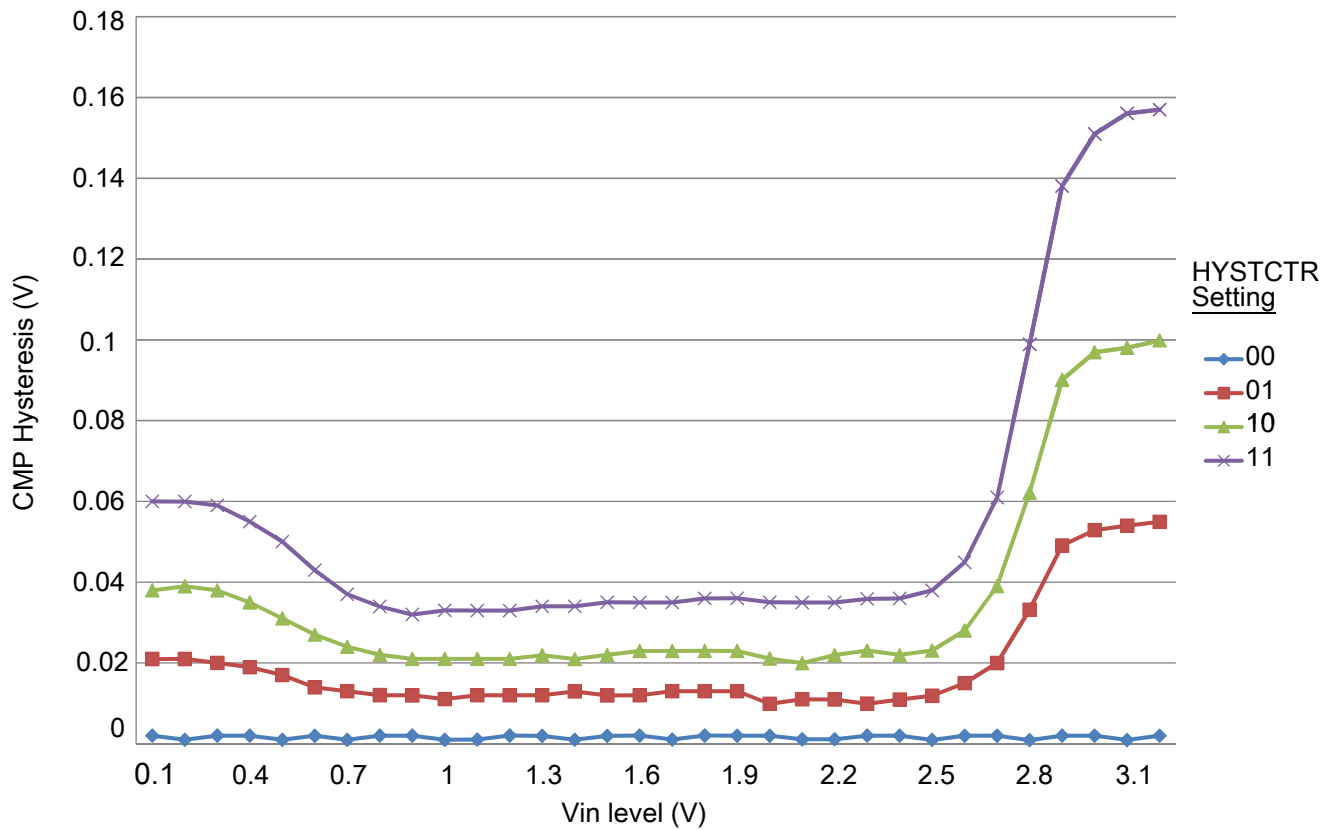

Figure 13. Typical hysteresis vs. Vin level ($V_{DD} = 3.3\text{ V}$, $PMODE = 1$)

9.6 PWMs and timers

9.6.1 PWM characteristics

Table 32. PWM timing parameters

Characteristic	Symbol	Min	Typ	Max	Unit
PWM clock frequency			60		MHz

9.6.2 Quad Timer timing

Parameters listed are guaranteed by design.

Table 33. Timer timing

Characteristic	Symbol	Min ¹	Max	Unit	See Figure
Timer input period	P_{IN}	$2T + 6$	—	ns	Figure 14

Table continues on the next page...

Table 33. Timer timing (continued)

Characteristic	Symbol	Min ¹	Max	Unit	See Figure
Timer input high/low period	P _{INHL}	1T + 3	—	ns	Figure 14
Timer output period	P _{OUT}	33	—	ns	Figure 14
Timer output high/low period	P _{OUTHL}	16.7	—	ns	Figure 14

1. T = clock cycle. For 60 MHz operation, T = 16.7 ns.

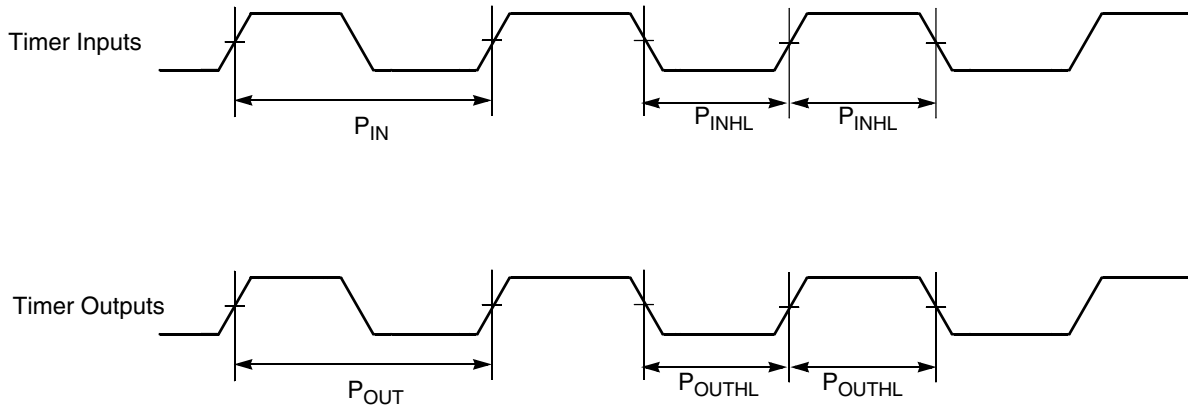

Figure 14. Timer timing

9.7 Communication interfaces

9.7.1 Queued Serial Peripheral Interface (SPI) timing

Parameters listed are guaranteed by design.

Table 34. SPI timing

Characteristic	Symbol	Min	Max	Unit	See Figure
Cycle time	t _C	55	—	ns	Figure 15
Master		55	—	ns	Figure 16
Slave					Figure 17
					Figure 18
Enable lead time	t _{ELD}	—	—	ns	Figure 18
Master				ns	
Slave				ns	
Enable lag time	t _{ELG}	—	—	ns	Figure 18
Master				ns	
Slave				ns	

Table continues on the next page...

Table 34. SPI timing (continued)

Characteristic	Symbol	Min	Max	Unit	See Figure	
Clock (SCK) high time	t_{CH}	27.6	—	ns	Figure 15	
		Master	27.6	—	ns	Figure 16
		Slave				Figure 17 Figure 18
Clock (SCK) low time	t_{CL}	27.6	—	ns	Figure 18	
		Master	27.6	—	ns	
		Slave				
Data set-up time required for inputs	t_{DS}	27.6	—	ns	Figure 15	
		Master	1	—	ns	Figure 16
		Slave				Figure 17 Figure 18
Data hold time required for inputs	t_{DH}	1	—	ns	Figure 15	
		Master	3	—	ns	Figure 16
		Slave				Figure 17 Figure 18
Access time (time to data active from high-impedance state)	t_A	5	—	ns	Figure 18	
Slave						
Disable time (hold time to high-impedance state)	t_D	5	—	ns	Figure 18	
Slave						
Data valid for outputs	t_{DV}	—	8.3	ns	Figure 15	
		Master	—	25	ns	Figure 16
		Slave (after enable edge)				Figure 17 Figure 18
Data invalid	t_{DI}	0	—	ns	Figure 15	
		Master	0	—	ns	Figure 16
		Slave				Figure 17 Figure 18
Rise time	t_R	—	1	ns	Figure 15	
		Master	—	1	ns	Figure 16
		Slave				Figure 17 Figure 18
Fall time	t_F	—	1	ns	Figure 15	
		Master	—	1	ns	Figure 16
		Slave				Figure 17 Figure 18

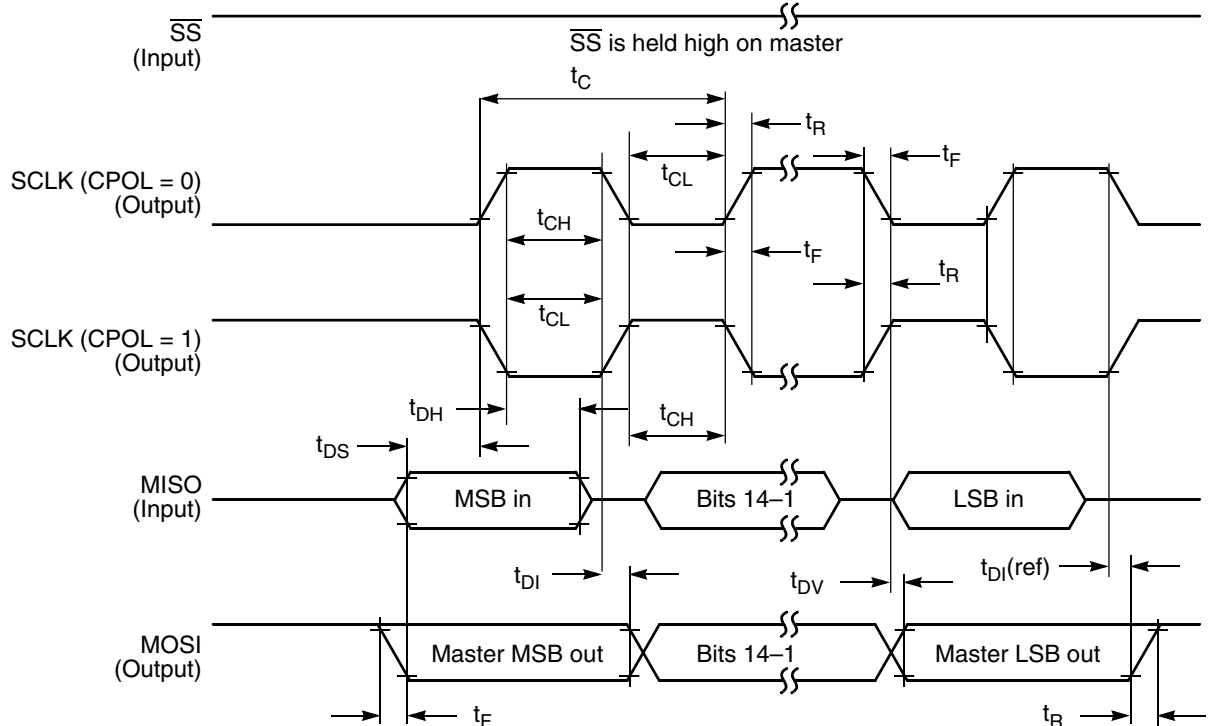

Figure 15. SPI master timing (CPHA = 0)

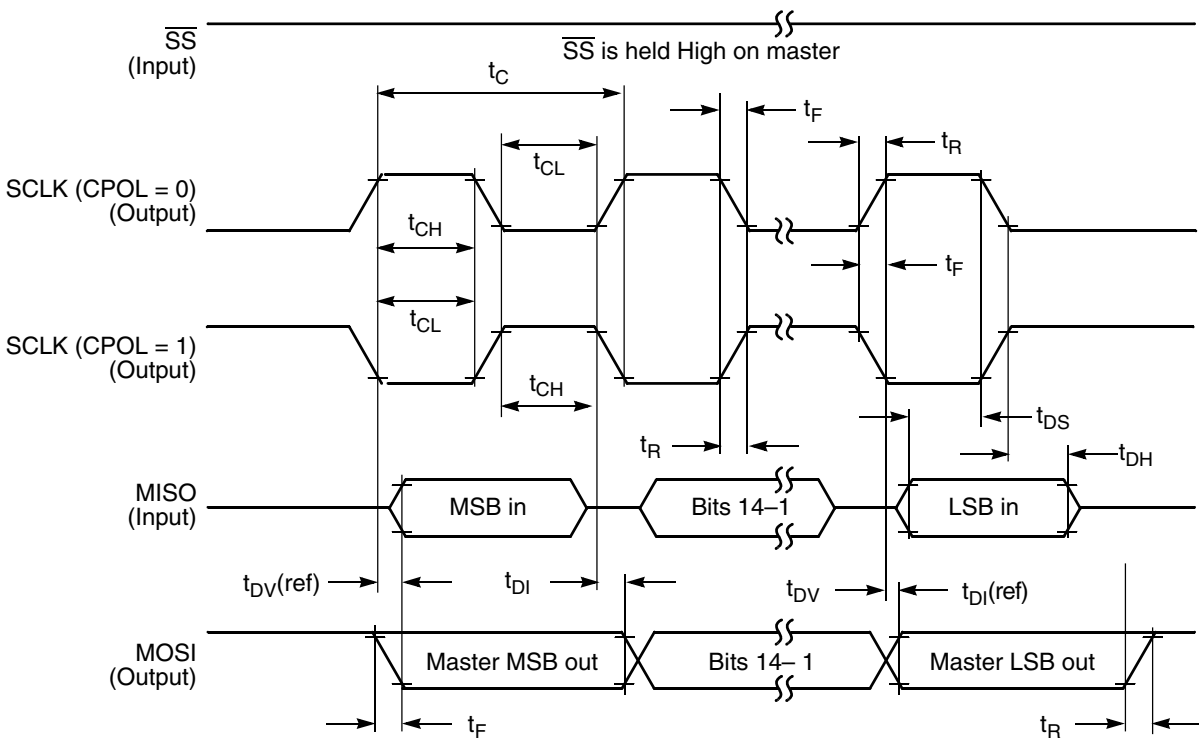

Figure 16. SPI master timing (CPHA = 1)

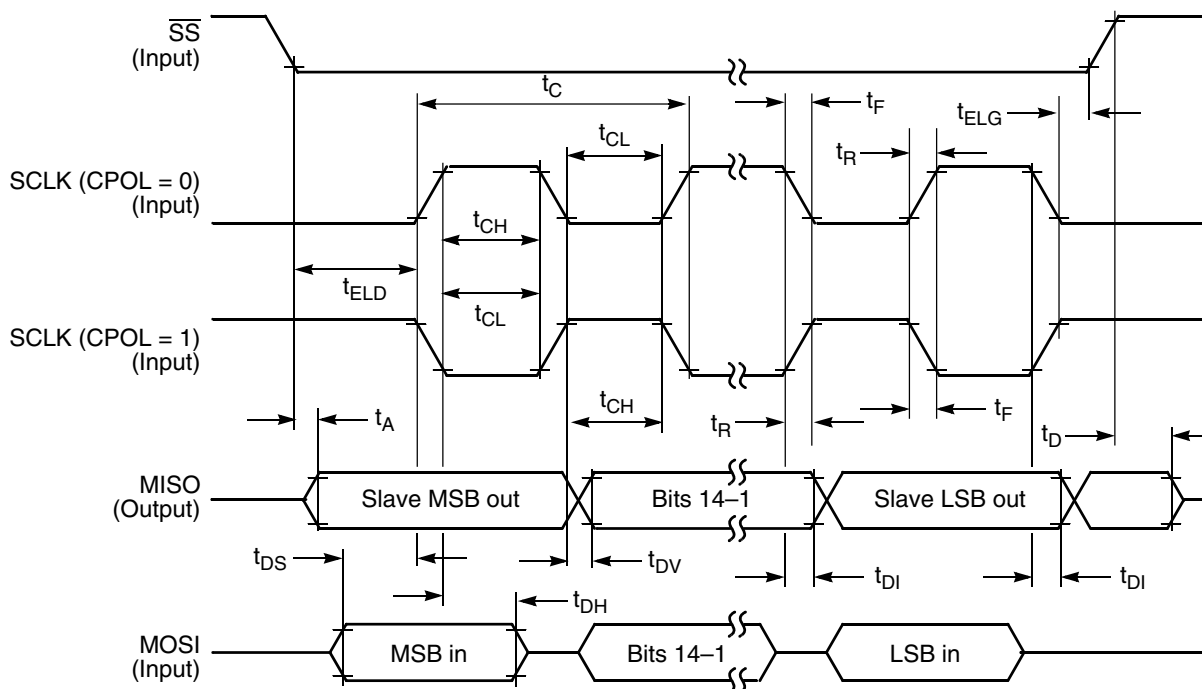

Figure 17. SPI slave timing (CPHA = 0)

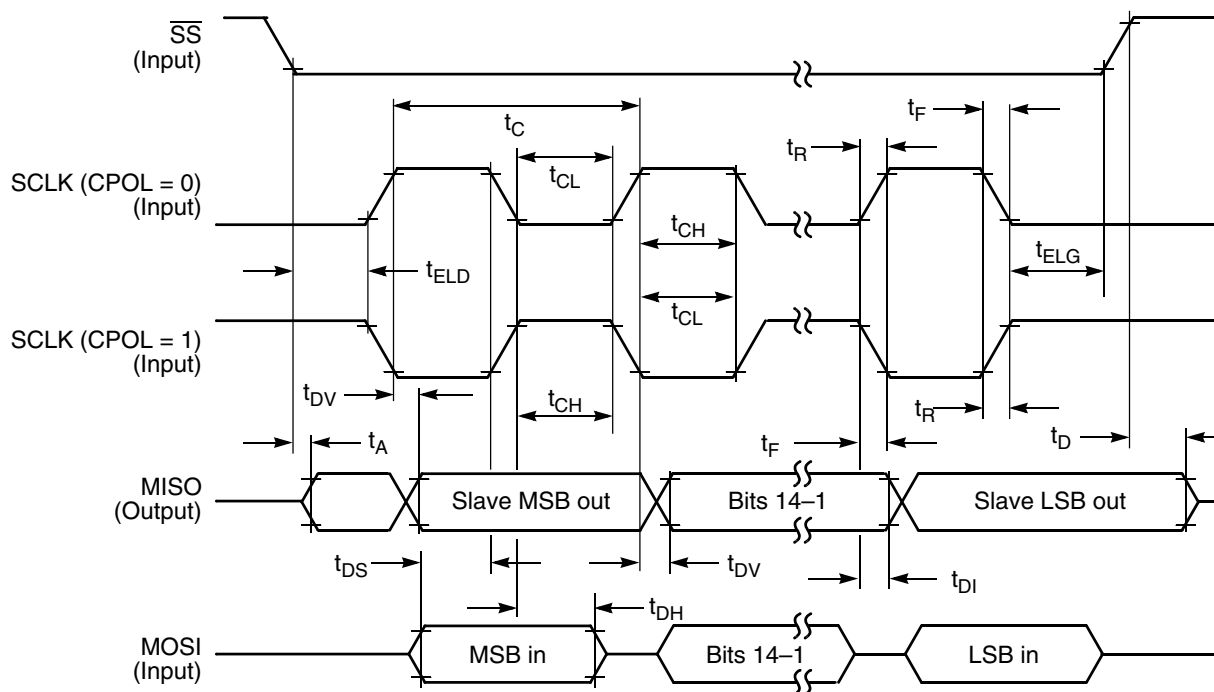

Figure 18. SPI slave timing (CPHA = 1)

9.7.2 Queued Serial Communication Interface (SCI) timing

Parameters listed are guaranteed by design.

Table 35. SCI timing

Characteristic	Symbol	Min	Max	Unit	See Figure
Baud rate ¹	BR	—	($f_{MAX}/16$)	Mbit/s	—
RXD pulse width	RXD _{PW}	0.965/BR	1.04/BR	ns	Figure 19
TXD pulse width	TXD _{PW}	0.965/BR	1.04/BR	ns	Figure 20
LIN Slave Mode					
Deviation of slave node clock from nominal clock rate before synchronization	F _{TOL_UNSYNCH}	-14	14	%	—
Deviation of slave node clock relative to the master node clock after synchronization	F _{TOL_SYNCH}	-2	2	%	—
Minimum break character length	T _{BREAK}	13	—	Master node bit periods	—
		11	—	Slave node bit periods	—

1. f_{MAX} is the frequency of operation of the SCI clock in MHz, which can be selected as the bus clock (max.120 MHz depending on part number) or 2x bus clock (max. MHz) for the devices.

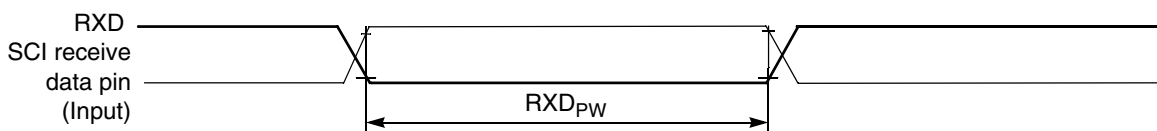

Figure 19. RXD pulse width

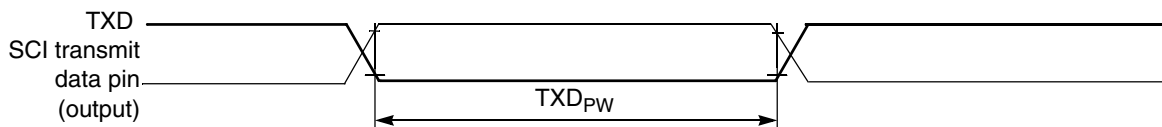
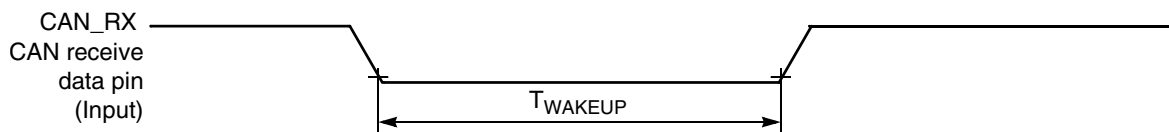

Figure 20. TXD pulse width

9.7.3 Freescale’s Scalable Controller Area Network (FlexCAN)

Table 36. FlexCAN Timing Parameters

Characteristic	Symbol	Min	Max	Unit
Baud Rate	BR _{CAN}	—	1	Mbps
CAN Wakeup dominant pulse filtered	T _{WAKEUP}	—	2	μs
CAN Wakeup dominant pulse pass	T _{WAKEUP}	5	—	μs

Figure 21. Bus Wake-up Detection

9.7.4 Inter-Integrated Circuit Interface (I²C) timing

Table 37. I²C timing

Characteristic	Symbol	Standard Mode		Fast Mode		Unit
		Minimum	Maximum	Minimum	Maximum	
SCL Clock Frequency	f_{SCL}	0	100	0	400	kHz
Hold time (repeated) START condition. After this period, the first clock pulse is generated.	$t_{HD}; STA$	4	—	0.6	—	μs
LOW period of the SCL clock	t_{LOW}	4.7	—	1.3	—	μs
HIGH period of the SCL clock	t_{HIGH}	4	—	0.6	—	μs
Set-up time for a repeated START condition	$t_{SU}; STA$	4.7	—	0.6	—	μs
Data hold time for I ² C bus devices	$t_{HD}; DAT$	0 ¹	3.45 ²	0 ³	0.9 ¹	μs
Data set-up time	$t_{SU}; DAT$	250 ⁴	—	100 ^{2, 5}	—	ns
Rise time of SDA and SCL signals	t_r	—	1000	$20 + 0.1C_b$ ⁶	300	ns
Fall time of SDA and SCL signals	t_f	—	300	$20 + 0.1C_b$ ⁵	300	ns
Set-up time for STOP condition	$t_{SU}; STO$	4	—	0.6	—	μs
Bus free time between STOP and START condition	t_{BUF}	4.7	—	1.3	—	μs
Pulse width of spikes that must be suppressed by the input filter	t_{SP}	N/A	N/A	0	50	ns

1. The master mode I²C deasserts ACK of an address byte simultaneously with the falling edge of SCL. If no slaves acknowledge this address byte, then a negative hold time can result, depending on the edge rates of the SDA and SCL lines.
2. The maximum $t_{HD}; DAT$ must be met only if the device does not stretch the LOW period (t_{LOW}) of the SCL signal.
3. Input signal Slew = 10 ns and Output Load = 50 pF
4. Set-up time in slave-transmitter mode is 1 IPBus clock period, if the TX FIFO is empty.
5. A Fast mode I²C bus device can be used in a Standard mode I²C bus system, but the requirement $t_{SU}; DAT \geq 250$ ns must then be met. This is automatically the case if the device does not stretch the LOW period of the SCL signal. If such a device does stretch the LOW period of the SCL signal, then it must output the next data bit to the SDA line $t_{rmax} + t_{SU}; DAT = 1000 + 250 = 1250$ ns (according to the Standard mode I²C bus specification) before the SCL line is released.
6. C_b = total capacitance of the one bus line in pF.

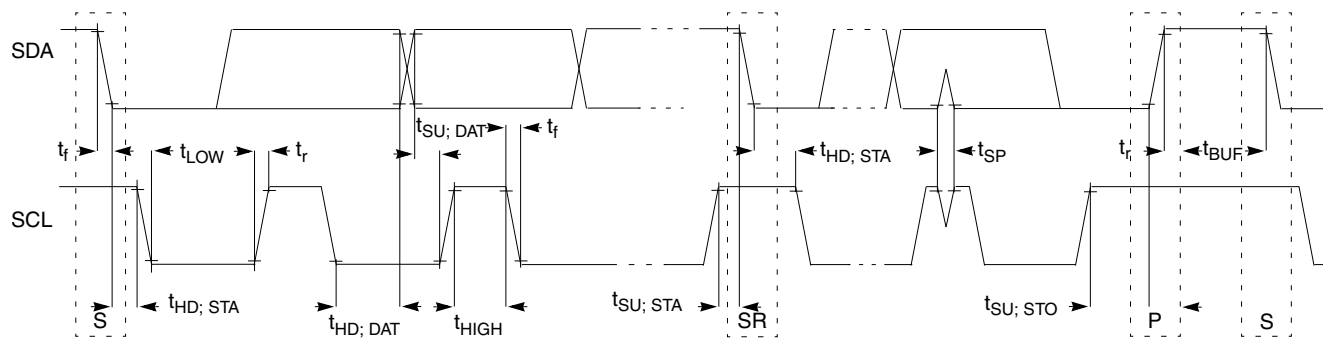

Figure 22. Timing definition for fast and standard mode devices on the I²C bus

10 Design Considerations

10.1 Thermal design considerations

An estimate of the chip junction temperature (T_J) can be obtained from the equation:

$$T_J = T_A + (R_{\theta JA} \times P_D)$$

Where,

T_A = Ambient temperature for the package (°C)

R_{θJA} = Junction-to-ambient thermal resistance (°C/W)

P_D = Power dissipation in the package (W)

The junction-to-ambient thermal resistance is an industry-standard value that provides a quick and easy estimation of thermal performance. Unfortunately, there are two values in common usage: the value determined on a single-layer board and the value obtained on a board with two planes. For packages such as the PBGA, these values can be different by a factor of two. Which T_J value is closer to the application depends on the power dissipated by other components on the board.

- The T_J value obtained on a single layer board is appropriate for a tightly packed printed circuit board.
- The T_J value obtained on a board with the internal planes is usually appropriate if the board has low-power dissipation and if the components are well separated.

When a heat sink is used, the thermal resistance is expressed as the sum of a junction-to-case thermal resistance and a case-to-ambient thermal resistance:

$$R_{\theta JA} = R_{\theta JC} + R_{\theta CA}$$

Where,

$R_{\Theta JA}$ = Package junction-to-ambient thermal resistance ($^{\circ}\text{C}/\text{W}$)

$R_{\Theta JC}$ = Package junction-to-case thermal resistance ($^{\circ}\text{C}/\text{W}$)

$R_{\Theta CA}$ = Package case-to-ambient thermal resistance ($^{\circ}\text{C}/\text{W}$)

$R_{\Theta JC}$ is device related and cannot be adjusted. You control the thermal environment to change the case to ambient thermal resistance, $R_{\Theta CA}$. For instance, you can change the size of the heat sink, the air flow around the device, the interface material, the mounting arrangement on printed circuit board, or change the thermal dissipation on the printed circuit board surrounding the device.

To determine the junction temperature of the device in the application when heat sinks are not used, the thermal characterization parameter (YJT) can be used to determine the junction temperature with a measurement of the temperature at the top center of the package case using the following equation:

$$T_J = T_T + (\Psi_{JT} \times P_D)$$

Where,

T_T = Thermocouple temperature on top of package ($^{\circ}\text{C}/\text{W}$)

Ψ_{JT} = thermal characterization parameter ($^{\circ}\text{C}/\text{W}$)

P_D = Power dissipation in package (W)

The thermal characterization parameter is measured per JESD51–2 specification using a 40-gauge type T thermocouple epoxied to the top center of the package case. The thermocouple should be positioned so that the thermocouple junction rests on the package. A small amount of epoxy is placed over the thermocouple junction and over about 1 mm of wire extending from the junction. The thermocouple wire is placed flat against the package case to avoid measurement errors caused by cooling effects of the thermocouple wire.

To determine the junction temperature of the device in the application when heat sinks are used, the junction temperature is determined from a thermocouple inserted at the interface between the case of the package and the interface material. A clearance slot or hole is normally required in the heat sink. Minimizing the size of the clearance is important to minimize the change in thermal performance caused by removing part of the thermal interface to the heat sink. Because of the experimental difficulties with this technique, many engineers measure the heat sink temperature and then back-calculate the case temperature using a separate measurement of the thermal resistance of the interface. From this case temperature, the junction temperature is determined from the junction-to-case thermal resistance.

10.2 Electrical design considerations

CAUTION

This device contains protective circuitry to guard against damage due to high static voltage or electrical fields. However, take normal precautions to avoid application of any voltages higher than maximum-rated voltages to this high-impedance circuit. Reliability of operation is enhanced if unused inputs are tied to an appropriate voltage level.

Use the following list of considerations to assure correct operation of the device:

- Provide a low-impedance path from the board power supply to each V_{DD} pin on the device and from the board ground to each V_{SS} (GND) pin.
- The minimum bypass requirement is to place 0.01–0.1 μF capacitors positioned as near as possible to the package supply pins. The recommended bypass configuration is to place one bypass capacitor on each of the V_{DD}/V_{SS} pairs, including V_{DDA}/V_{SSA} . Ceramic and tantalum capacitors tend to provide better tolerances.
- Ensure that capacitor leads and associated printed circuit traces that connect to the chip V_{DD} and V_{SS} (GND) pins are as short as possible.
- Bypass the V_{DD} and V_{SS} with approximately 100 μF , plus the number of 0.1 μF ceramic capacitors.
- PCB trace lengths should be minimal for high-frequency signals.
- Consider all device loads as well as parasitic capacitance due to PCB traces when calculating capacitance. This is especially critical in systems with higher capacitive loads that could create higher transient currents in the V_{DD} and V_{SS} circuits.
- Take special care to minimize noise levels on the V_{REF} , V_{DDA} , and V_{SSA} pins.
- Using separate power planes for V_{DD} and V_{DDA} and separate ground planes for V_{SS} and V_{SSA} are recommended. Connect the separate analog and digital power and ground planes as near as possible to power supply outputs. If an analog circuit and digital circuit are powered by the same power supply, then connect a small inductor or ferrite bead in serial with V_{DDA} . Traces of V_{SS} and V_{SSA} should be shorted together.
- Physically separate analog components from noisy digital components by ground planes. Do not place an analog trace in parallel with digital traces. Place an analog ground trace around an analog signal trace to isolate it from digital traces.
- Because the flash memory is programmed through the JTAG/EOnCE port, SPI, SCI, or I²C, the designer should provide an interface to this port if in-circuit flash programming is desired.
- If desired, connect an external RC circuit to the $\overline{\text{RESET}}$ pin. The resistor value should be in the range of 4.7 k Ω –10 k Ω ; the capacitor value should be in the range of 0.22 μF –4.7 μF .

- Configuring the $\overline{\text{RESET}}$ pin to GPIO output in normal operation in a high-noise environment may help to improve the performance of noise transient immunity.
- Add a 2.2 k Ω external pullup on the TMS pin of the JTAG port to keep EOnCE in a restate during normal operation if JTAG converter is not present.
- During reset and after reset but before I/O initialization, all I/O pins are at tri-state.
- To eliminate PCB trace impedance effect, each ADC input should have a no less than 33 pF 10 Ω RC filter.

11 Obtaining package dimensions

Package dimensions are provided in package drawings.

To find a package drawing, go to freescale.com and perform a keyword search for the drawing's document number:

Drawing for package	Document number to be used
48-pin LQFP	98ASH00962A
64-pin LQFP	98ASS23234W

12 Pinout

12.1 Signal Multiplexing and Pin Assignments

This section shows the signals available on each package pin and the locations of these pins on the devices supported by this document. The SIM's GPS registers are responsible for selecting which ALT functionality is available on most pins.

NOTE

The RESETB pin is a 3.3 V pin only.

NOTE

If the GPIOC1 pin is used as GPIO, the XOSC should be powered down.

NOTE

PWMB signals—including PWMB_2A, PWMB_2B, and PWMB_3X—are not available on the 64 LQFP package or the 48 LQFP package.

Pinout

64 LQFP	48 LQFP	Pin Name	Default	ALT0	ALT1	ALT2	ALT3
1	1	TCK	TCK	GPIOD2			
2	2	RESETB	RESETB	GPIOD4			
3	3	GPIOC0	GPIOC0	EXTAL	CLKIN0		
4	4	GPIOC1	GPIOC1	XTAL			
5	5	GPIOC2	GPIOC2	TXD0	TB0	XB_IN2	CLK00
6	—	GPIOF8	GPIOF8	RXD0	TB1	CMPD_O	
7	6	GPIOC3	GPIOC3	TA0	CMPA_O	RXD0	CLKIN1
8	7	GPIOC4	GPIOC4	TA1	CMPB_O	XB_IN8	EWM_OUT_B
9	—	GPIOA7	GPIOA7	ANA7&ANC11			
10	—	GPIOA6	GPIOA6	ANA6&ANC10			
11	—	GPIOA5	GPIOA5	ANA5&ANC9			
12	8	GPIOA4	GPIOA4	ANA4&ANC8&CMPD_IN0			
13	9	GPIOA0	GPIOA0	ANA0&CMPA_IN3	CMPC_O		
14	10	GPIOA1	GPIOA1	ANA1&CMPA_IN0			
15	11	GPIOA2	GPIOA2	ANA2&VREFHA&CMPA_IN1			
16	12	GPIOA3	GPIOA3	ANA3&VREFLA&CMPA_IN2			
17	—	GPIOB7	GPIOB7	ANB7&ANC15&CMPB_IN2			
18	13	GPIOC5	GPIOC5	DACO	XB_IN7		
19	—	GPIOB6	GPIOB6	ANB6&ANC14&CMPB_IN1			
20	—	GPIOB5	GPIOB5	ANB5&ANC13&CMPC_IN2			
21	14	GPIOB4	GPIOB4	ANB4&ANC12&CMPC_IN1			
22	15	VDDA	VDDA				
23	16	VSSA	VSSA				
24	17	GPIOB0	GPIOB0	ANB0&CMPB_IN3			
25	18	GPIOB1	GPIOB1	ANB1&CMPB_IN0			
26	19	VCAP	VCAP				
27	20	GPIOB2	GPIOB2	ANB2&VREFHB&CMPC_IN3			
28	21	GPIOB3	GPIOB3	ANB3&VREFLB&CMPC_IN0			
29	—	VDD	VDD				
30	22	VSS	VSS				
31	23	GPIOC6	GPIOC6	TA2	XB_IN3	CMP_REF	
32	24	GPIOC7	GPIOC7	SS0_B	TXD0		
33	25	GPIOC8	GPIOC8	MISO0	RXD0	XB_IN9	
34	26	GPIOC9	GPIOC9	SCLK0	XB_IN4		
35	27	GPIOC10	GPIOC10	MOSI0	XB_IN5	MISO0	
36	28	GPIOF0	GPIOF0	XB_IN6	TB2	SCLK1	
37	29	GPIOC11	GPIOC11	CANTX	SCL1	TXD1	
38	30	GPIOC12	GPIOC12	CANRX	SDA1	RXD1	
39	—	GPIOF2	GPIOF2	SCL1	XB_OUT6		
40	—	GPIOF3	GPIOF3	SDA1	XB_OUT7		
41	—	GPIOF4	GPIOF4	TXD1	XB_OUT8		

64 LQFP	48 LQFP	Pin Name	Default	ALT0	ALT1	ALT2	ALT3
42	—	GPIOF5	GPIOF5	RXD1	XB_OUT9		
43	31	VSS	VSS				
44	32	VDD	VDD				
45	33	GPIOE0	GPIOE0	PWMA_0B			
46	34	GPIOE1	GPIOE1	PWMA_0A			
47	35	GPIOE2	GPIOE2	PWMA_1B			
48	36	GPIOE3	GPIOE3	PWMA_1A			
49	37	GPIOC13	GPIOC13	TA3	XB_IN6	EWM_OUT_B	
50	38	GPIOF1	GPIOF1	CLKO1	XB_IN7	CMPD_O	
51	39	GPIOE4	GPIOE4	PWMA_2B	XB_IN2		
52	40	GPIOE5	GPIOE5	PWMA_2A	XB_IN3		
53	—	GPIOE6	GPIOE6	PWMA_3B	XB_IN4		
54	—	GPIOE7	GPIOE7	PWMA_3A	XB_IN5		
55	41	GPIOC14	GPIOC14	SDA0	XB_OUT4		
56	42	GPIOC15	GPIOC15	SCL0	XB_OUT5		
57	43	VCAP	VCAP				
58	—	GPIOF6	GPIOF6	TB2	PWMA_3X		XB_IN2
59	—	GPIOF7	GPIOF7	TB3	CMPC_O	SS1_B	XB_IN3
60	44	VDD	VDD				
61	45	VSS	VSS				
62	46	TDO	TDO	GPIOD1			
63	47	TMS	TMS	GPIOD3			
64	48	TDI	TDI	GPIOD0			

12.2 Pinout diagrams

The following diagrams show pinouts for the packages. For each pin, the diagrams show the default function. However, many signals may be multiplexed onto a single pin.

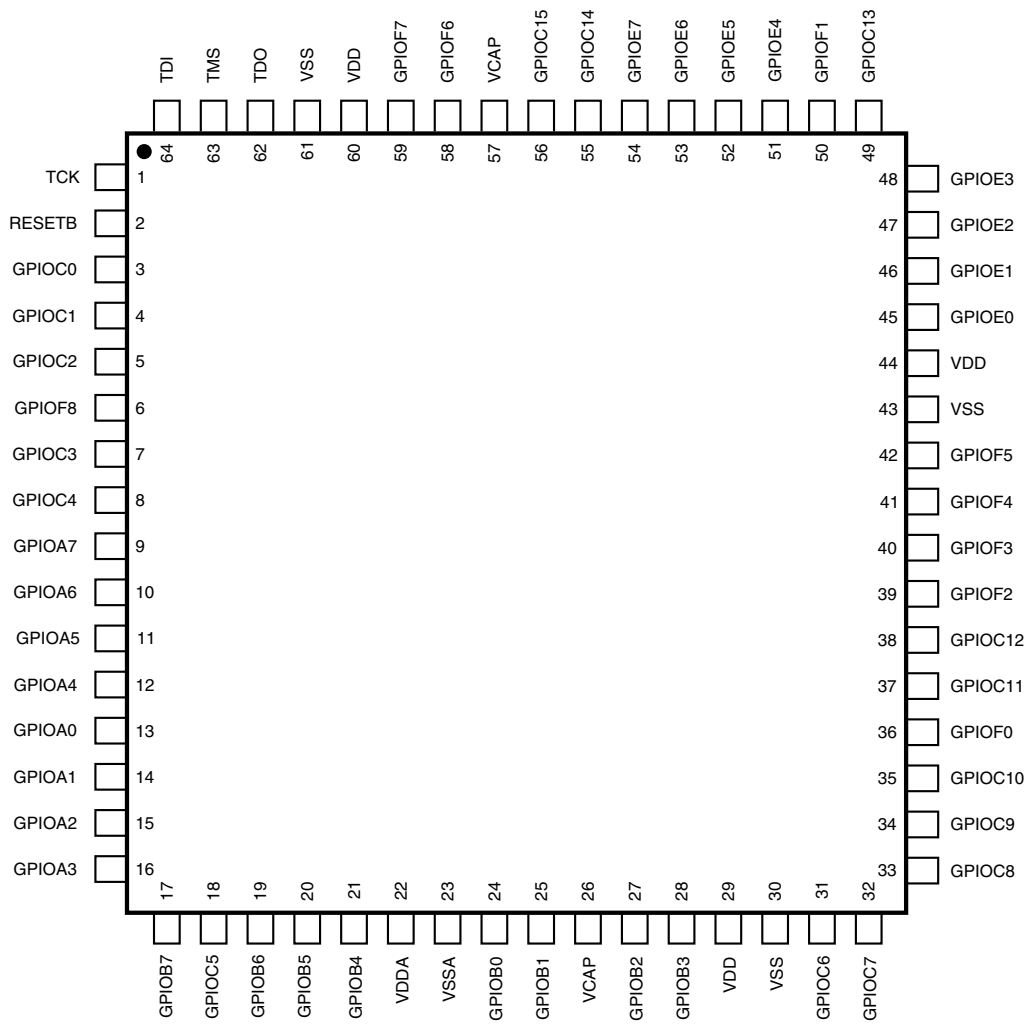

Figure 23. 64-pin LQFP

NOTE

The RESETB pin is a 3.3 V pin only.

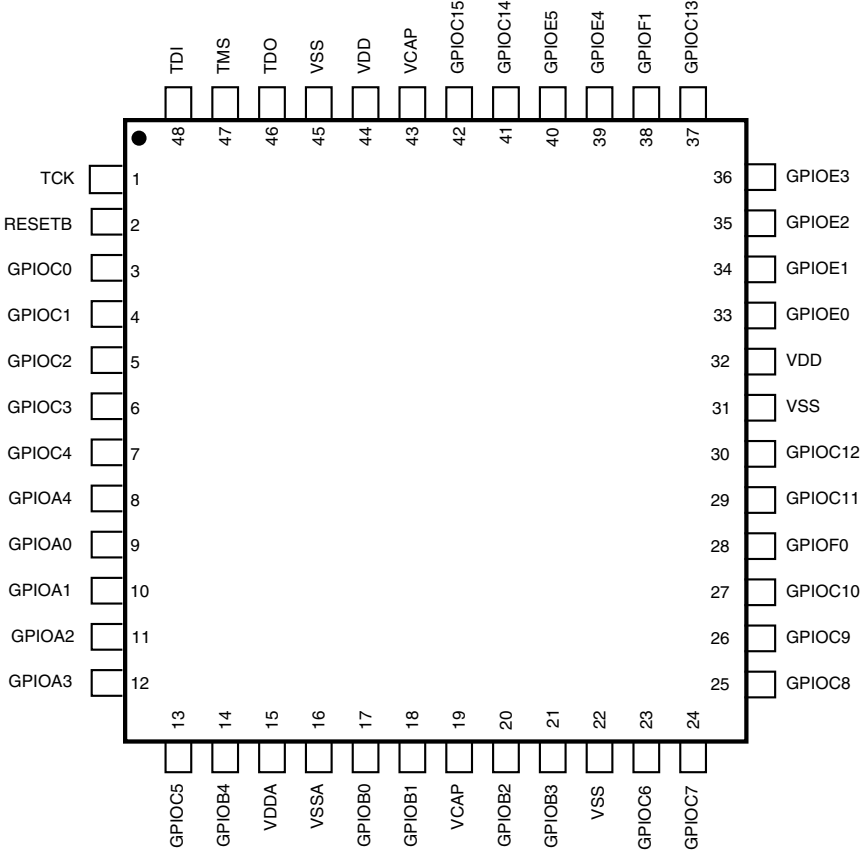

Figure 24. 48-pin LQFP

NOTE

The RESETB pin is a 3.3 V pin only.

13 Product documentation

The documents listed in [Table 38](#) are required for a complete description and proper design with the device. Documentation is available from local Freescale distributors, Freescale Semiconductor sales offices, or online at freescale.com.

Table 38. Device documentation

Topic	Description	Document Number
DSP56800E/DSP56800EX Reference Manual	Detailed description of the 56800EX family architecture, 32-bit digital signal controller core processor, and the instruction set	DSP56800ERM
MC56F844xx Reference Manual	Detailed functional description and programming model	MC56F844XXRM
MC56F844xx Data Sheet	Electrical and timing specifications, pin descriptions, and package information (this document)	MC56F844XX
MC56F84xxx Errata	Details any chip issues that might be present	MC56F84XXX_0N27E

14 Revision history

The following table summarizes changes to this document since the release of the previous version.

Table 39. Revision history

Rev.	Date	Substantial Changes
3	06/2014	Changes include: <ul style="list-style-type: none"> • Correction to "PWMs and timers" feature group on page 1 • Correction: there is 1 queued SPI module, not 2. • Updates and corrections to "56F844xx/5xx/7xx family" table. • In "Interrupt Controller" section, added info about Interrupt level 3. • In "Enhanced Flex Pulse Width Modulator (eFlexPWM)" section, <ul style="list-style-type: none"> • Updated PWM frequencies based on device frequency, plus updated resolution of fractional clock digital dithering. • Updated feature list. • Added new section "MC56F844xx signal and pin descriptions". • In "Signal groups" section, in "Functional Group Pin Allocations" table, made corrections to "Functional Group Pin Allocations" table. • In "Voltage and current operating requirements" section, added RESET voltage high to "Recommended Operating Conditions" table. • In "Voltage and current operating behaviors" section, in "DC Electrical Characteristics" table, updated Digital Input Current High for Pin Group 2. • For "Power mode transition operating behaviors" section, <ul style="list-style-type: none"> • Changed the name to "Power mode operating behaviors". • In "Reset, Stop, Wait, and Interrupt Timing" table, updated "RESET deassertion to First Address Fetch" parameters. • Added new table "Power-On-Reset mode transition times". • In "Power consumption operating behaviors" section, updated mode current values in "Current Consumption" table. • In "JTAG Timing" section, changed "TCK frequency of operation" to SYS_CLK/16 from SYS_CLK/8. • In "System modules" section, in "Voltage regulator specifications" section, in "Regulator 1.2 V parameters" table, updated "Short Circuit Current" parameter. • In "Relaxation Oscillator Timing" section, updates in "Relaxation Oscillator Electrical Specifications" table. • In "Memories and memory interfaces" section, <ul style="list-style-type: none"> • "Flash Memory Characteristics" section is now called "Flash electrical specifications" section. • Added new section "Flash timing specifications — program and erase", where the "Flash Timing Parameters" table (now called "NVM program/erase timing specifications" table, and table was updated. • Added new section "Flash high voltage current behaviors". • In "Analog" section, in "12-bit cyclic Analog-to-Digital Converter (ADC) parameters" section, updated "12-bit ADC electrical specifications" table. • In "Pinout" section, in "Signal Multiplexing and Pin Assignments" section, <ul style="list-style-type: none"> • Added 3 notes. • In pin mux table, changed SCK0 to SCLK0, SCK1 to SCLK1, updates to 64LQFP[62-64] and 48LQFP[46-48]. • In "64-pin LQFP" figure, made updates to pins 62-64, and added a note. • In "48-pin LQFP" figure, made updates to pins 46-48, and added a note. • In "Product Documentation" section, in "Device Documentation" table, removed Serial Bootloader User Guide, because it is not used for these devices.

How to Reach Us:

Home Page:

www.freescale.com

Web Support:

<http://www.freescale.com/support>

USA/Europe or Locations Not Listed:

Freescale Semiconductor
Technical Information Center, EL516
2100 East Elliot Road
Tempe, Arizona 85284
+1-800-521-6274 or +1-480-768-2130
www.freescale.com/support

Europe, Middle East, and Africa:

Freescale Halbleiter Deutschland GmbH
Technical Information Center
Schatzbogen 7
81829 Muenchen, Germany
+44 1296 380 456 (English)
+46 8 52200080 (English)
+49 89 92103 559 (German)
+33 1 69 35 48 48 (French)
www.freescale.com/support

Japan:

Freescale Semiconductor Japan Ltd.
Headquarters
ARCO Tower 15F
1-8-1, Shimo-Meguro, Meguro-ku,
Tokyo 153-0064
Japan
0120 191014 or +81 3 5437 9125
support.japan@freescale.com

Asia/Pacific:

Freescale Semiconductor China Ltd.
Exchange Building 23F
No. 118 Jianguo Road
Chaoyang District
Beijing 100022
China
+86 10 5879 8000
support.asia@freescale.com

Information in this document is provided solely to enable system and software implementers to use Freescale Semiconductors products. There are no express or implied copyright licenses granted hereunder to design or fabricate any integrated circuits or integrated circuits based on the information in this document.

Freescale Semiconductor reserves the right to make changes without further notice to any products herein. Freescale Semiconductor makes no warranty, representation, or guarantee regarding the suitability of its products for any particular purpose, nor does Freescale Semiconductor assume any liability arising out of the application or use of any product or circuit, and specifically disclaims any liability, including without limitation consequential or incidental damages. "Typical" parameters that may be provided in Freescale Semiconductor data sheets and/or specifications can and do vary in different applications and actual performance may vary over time. All operating parameters, including "Typicals", must be validated for each customer application by customer's technical experts. Freescale Semiconductor does not convey any license under its patent rights nor the rights of others. Freescale Semiconductor products are not designed, intended, or authorized for use as components in systems intended for surgical implant into the body, or other applications intended to support or sustain life, or for any other application in which failure of the Freescale Semiconductor product could create a situation where personal injury or death may occur. Should Buyer purchase or use Freescale Semiconductor products for any such unintended or unauthorized application, Buyer shall indemnify Freescale Semiconductor and its officers, employees, subsidiaries, affiliates, and distributors harmless against all claims, costs, damages, and expenses, and reasonable attorney fees arising out of, directly or indirectly, any claim of personal injury or death associated with such unintended or unauthorized use, even if such claims alleges that Freescale Semiconductor was negligent regarding the design or manufacture of the part.

RoHS-compliant and/or Pb-free versions of Freescale products have the functionality and electrical characteristics as their non-RoHS-complaint and/or non-Pb-free counterparts. For further information, see <http://www.freescale.com> or contact your Freescale sales representative.

For information on Freescale's Environmental Products program, go to <http://www.freescale.com/epp>.

Freescale™ and the Freescale logo are trademarks of Freescale Semiconductor, Inc. All other product or service names are the property of their respective owners.

© 2014 Freescale Semiconductor, Inc.

Looking for pricing, stock, or lifecycle information?

Click below to explore more details on WIN SOURCE:

- ⊖ [View MC56F84441VLF on WIN SOURCE](#)
- ⊖ [Freescale Semiconductor - NXP Information](#)

Optimize Your Supply Chain with WIN SOURCE Solutions

- ✓ Global Sourcing Solution
- ✓ Obsolete Management
- ✓ Cost Control Management
- ✓ Shortage Management
- ✓ Alternative Solution
- ✓ Excess Inventory Management