



**THE DATASHEET OF  
MC34025DWR2G**



# MC34025, MC33025

## High Speed Double-Ended PWM Controller

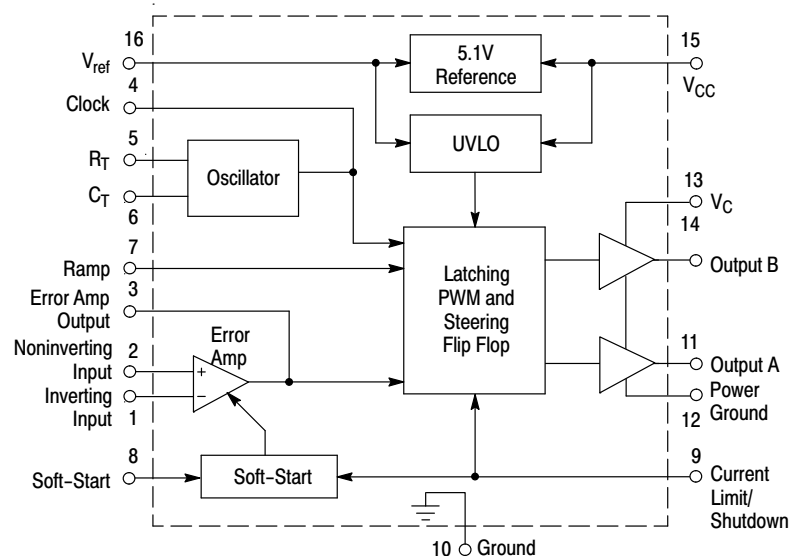
The MC34025 series are high speed, fixed frequency, double-ended pulse width modulator controllers optimized for high frequency operation. They are specifically designed for Off-Line and DC-to-DC converter applications offering the designer a cost effective solution with minimal external components. These integrated circuits feature an oscillator, a temperature compensated reference, a wide bandwidth error amplifier, a high speed current sensing comparator, steering flip-flop, and dual high current totem pole outputs ideally suited for driving power MOSFETs.

Also included are protective features consisting of input and reference undervoltage lockouts each with hysteresis, cycle-by-cycle current limiting, and a latch for single pulse metering.

The flexibility of this series allows it to be easily configured for either current mode or voltage mode control.

### Features

- 50 ns Propagation Delay to Outputs
- Dual High Current Totem Pole Outputs
- Wide Bandwidth Error Amplifier
- Fully-Latched Logic with Double Pulse Suppression
- Latching PWM for Cycle-By-Cycle Current Limiting
- Soft-Start Control with Latched Overcurrent Reset
- Input Undervoltage Lockout with Hysteresis
- Low Startup Current (500  $\mu$ A Typ)
- Internally Trimmed Reference with Undervoltage Lockout
- 45% Maximum Duty Cycle (Externally Adjustable)
- Precision Trimmed Oscillator
- Voltage or Current Mode Operation to 1.0 MHz
- Functionally Similar to the UC3825
- These Devices are Pb-Free, Halogen Free/BFR Free and are RoHS Compliant



This device contains 227 active transistors.

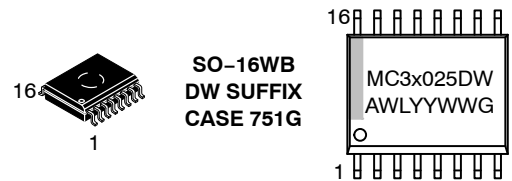
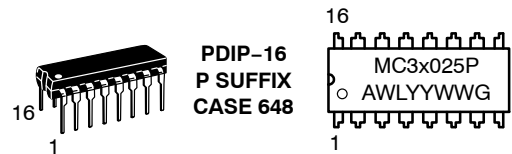
**Figure 1. Simplified Application**



**ON Semiconductor**<sup>®</sup>

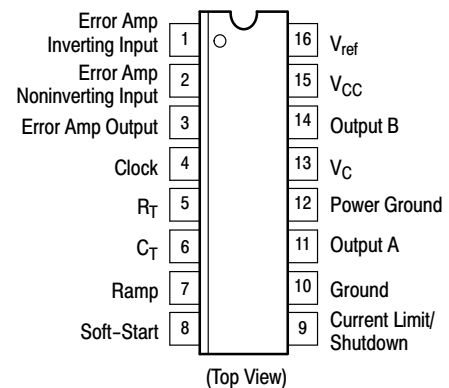
<http://onsemi.com>

### MARKING DIAGRAMS



- x = 3 or 4
- A = Assembly Location
- WL = Wafer Lot
- YY = Year
- WW = Work Week
- G = Pb-Free Package

### PIN CONNECTIONS



### ORDERING INFORMATION

See detailed ordering and shipping information in the package dimensions section on page 18 of this data sheet.

\*For additional information on our Pb-Free strategy and soldering details, please download the ON Semiconductor Soldering and Mounting Techniques Reference Manual, SOLDERRM/D.

# MC34025, MC33025

## MAXIMUM RATINGS

| Rating   | Symbol   | Value                     | Unit  |
|--|--|---------------------------|---|
| Power Supply Voltage   | $V_{CC}$   | 30                        | V   |
| Output Driver Supply Voltage   | $V_C$  | 25                        | V   |
| Output Current, Source or Sink (Note 1)<br>DC<br>Pulsed (0.5 $\mu$ s)  | $I_O$  | 0.5<br>2.0                | A   |
| Current Sense, Soft-Start, Ramp, and Error Amp Inputs  | $V_{in}$   | -0.3 to +7.0              | V   |
| Error Amp Output and Soft-Start Sink Current   | $I_O$  | 10                        | mA  |
| Clock and $R_T$ Output Current   | $I_{CO}$   | 5.0                       | mA  |
| Power Dissipation and Thermal Characteristics<br>SO-16 Package (Case 751G)<br>Maximum Power Dissipation @ $T_A = +25^\circ\text{C}$<br>Thermal Resistance, Junction-to-Air<br>DIP Package (Case 648)<br>Maximum Power Dissipation @ $T_A = +25^\circ\text{C}$<br>Thermal Resistance, Junction-to-Air | $P_D$<br>$R_{\theta JA}$<br>$P_D$<br>$R_{\theta JA}$ | 862<br>145<br>1.25<br>100 | mW<br>$^\circ\text{C/W}$<br>W<br>$^\circ\text{C/W}$ |
| Operating Junction Temperature   | $T_J$  | +150                      | $^\circ\text{C}$                                    |
| Operating Ambient Temperature (Note 2)<br>MC34025<br>MC33025   | $T_A$  | 0 to +70<br>-40 to +105   | $^\circ\text{C}$                                    |
| Storage Temperature Range  | $T_{stg}$  | -55 to +150               | $^\circ\text{C}$                                    |
| Human Body Model ESD Capability per JEDEC - JESD22-A114F   | HBM  | 2000                      | V   |
| Machine Model ESD Capability per JEDEC - JESD22-A115C  | MM   | 200                       | V   |

Stresses exceeding Maximum Ratings may damage the device. Maximum Ratings are stress ratings only. Functional operation above the Recommended Operating Conditions is not implied. Extended exposure to stresses above the Recommended Operating Conditions may affect device reliability.

**ELECTRICAL CHARACTERISTICS** ( $V_{CC} = 15\text{ V}$ ,  $R_T = 3.65\text{ k}\Omega$ ,  $C_T = 1.0\text{ nF}$ , for typical values  $T_A = +25^\circ\text{C}$ , for min/max values  $T_A$  is the operating ambient temperature range that applies [Note 2], unless otherwise noted.)

| Characteristic | Symbol | Min | Typ | Max | Unit |
|----------------|--------|-----|-----|-----|------|
|----------------|--------|-----|-----|-----|------|

## REFERENCE SECTION

|  |              |      |     |      |                      |
|--|--------------|------|-----|------|----------------------|
| Reference Output Voltage ( $I_O = 1.0\text{ mA}$ , $T_J = +25^\circ\text{C}$ )           | $V_{ref}$    | 5.05 | 5.1 | 5.15 | V                    |
| Line Regulation ( $V_{CC} = 10\text{ V to }30\text{ V}$ )                                | $Reg_{line}$ | -    | 2.0 | 15   | mV                   |
| Load Regulation ( $I_O = 1.0\text{ mA to }10\text{ mA}$ )                                | $Reg_{load}$ | -    | 2.0 | 15   | mV                   |
| Temperature Stability  | $T_S$        | -    | 0.2 | -    | mV/ $^\circ\text{C}$ |
| Total Output Variation over Line, Load, and Temperature                                  | $V_{ref}$    | 4.95 | -   | 5.25 | V                    |
| Output Noise Voltage ( $f = 10\text{ Hz to }10\text{ kHz}$ , $T_J = +25^\circ\text{C}$ ) | $V_n$        | -    | 50  | -    | $\mu\text{V}$        |
| Long Term Stability ( $T_A = +125^\circ\text{C}$ for 1000 Hours)                         | S            | -    | 5.0 | -    | mV                   |
| Output Short Circuit Current   | $I_{SC}$     | -30  | -65 | -100 | mA                   |

## OSCILLATOR SECTION

|   |                           |            |            |            |     |
|---|---------------------------|------------|------------|------------|-----|
| Frequency<br>Line ( $V_{CC} = 10\text{ V to }30\text{ V}$ ) and Temperature ( $T_A = T_{low}$ to $T_{high}$ ) | $f_{osc}$                 | 380<br>370 | 400<br>400 | 420<br>430 | kHz |
| Frequency Change with Voltage ( $V_{CC} = 10\text{ V to }30\text{ V}$ )                                       | $\Delta f_{osc}/\Delta V$ | -          | 0.2        | 1.0        | %   |
| Frequency Change with Temperature ( $T_A = T_{low}$ to $T_{high}$ )   | $\Delta f_{osc}/\Delta T$ | -          | 2.0        | -          | %   |
| Sawtooth Peak Voltage   | $V_P$                     | 2.6        | 2.8        | 3.0        | V   |
| Sawtooth Valley Voltage   | $V_V$                     | 0.7        | 1.0        | 1.25       | V   |
| Clock Output Voltage<br>High State<br>Low State   | $V_{OH}$<br>$V_{OL}$      | 3.9<br>-   | 4.5<br>2.3 | -<br>2.9   | V   |

- Maximum package power dissipation limits must be observed.
- Low duty cycle pulse techniques are used during test to maintain junction temperature as close to ambient as possible.  
 $T_{low} = 0^\circ\text{C}$  for MC34025       $T_{high} = +70^\circ\text{C}$  for MC34025  
 $= -40^\circ\text{C}$  for MC33025       $= +105^\circ\text{C}$  for MC33025

# MC34025, MC33025

**ELECTRICAL CHARACTERISTICS** ( $V_{CC} = 15\text{ V}$ ,  $R_T = 3.65\text{ k}\Omega$ ,  $C_T = 1.0\text{ nF}$ , for typical values  $T_A = +25^\circ\text{C}$ , for min/max values  $T_A$  is the operating ambient temperature range that applies [Note 4], unless otherwise noted.)

| Characteristic | Symbol | Min | Typ | Max | Unit |
|----------------|--------|-----|-----|-----|------|
|----------------|--------|-----|-----|-----|------|

## ERROR AMPLIFIER SECTION

|   |                            |            |             |            |                  |
|---|----------------------------|------------|-------------|------------|------------------|
| Input Offset Voltage  | $V_{IO}$                   | –          | –           | 15         | mV               |
| Input Bias Current  | $I_{IB}$                   | –          | 0.6         | 3.0        | $\mu\text{A}$    |
| Input Offset Current  | $I_{IO}$                   | –          | 0.1         | 1.0        | $\mu\text{A}$    |
| Open-Loop Voltage Gain ( $V_O = 1.0\text{ V to }4.0\text{ V}$ )                                       | $A_{VOL}$                  | 60         | 95          | –          | dB               |
| Gain Bandwidth Product ( $T_J = +25^\circ\text{C}$ )  | GBW                        | 4.0        | 8.3         | –          | MHz              |
| Common Mode Rejection Ratio ( $V_{CM} = 1.5\text{ V to }5.5\text{ V}$ )                               | CMRR                       | 75         | 95          | –          | dB               |
| Power Supply Rejection Ratio ( $V_{CC} = 10\text{ V to }30\text{ V}$ )                                | PSRR                       | 85         | 110         | –          | dB               |
| Output Current,<br>Source ( $V_O = 4.0\text{ V}$ )<br>Sink ( $V_O = 1.0\text{ V}$ )                   | $I_{Source}$<br>$I_{Sink}$ | 0.5<br>1.0 | 3.0<br>3.6  | –<br>–     | mA               |
| Output Voltage Swing,<br>High State ( $I_O = -0.5\text{ mA}$ )<br>Low State ( $I_O = 1.0\text{ mA}$ ) | $V_{OH}$<br>$V_{OL}$       | 4.5<br>0   | 4.75<br>0.4 | 5.0<br>1.0 | V                |
| Slew Rate   | SR                         | 6.0        | 12          | –          | V/ $\mu\text{s}$ |

## PWM COMPARATOR SECTION

|  |  |         |         |        |               |
|--|--|---------|---------|--------|---------------|
| Ramp Input Bias Current  | $I_{IB}$                                   | –       | –0.5    | –5.0   | $\mu\text{A}$ |
| Duty Cycle of Each Output,<br>Maximum<br>Minimum                     | DC <sub>(max)</sub><br>DC <sub>(min)</sub> | 40<br>– | 45<br>– | –<br>0 | %             |
| Zero Duty Cycle Threshold Voltage Pin 3(4) (Pin 7(9) = 0 V)          | $V_{th}$                                   | 1.1     | 1.25    | 1.4    | V             |
| Propagation Delay (Ramp Input to Output, $T_J = +25^\circ\text{C}$ ) | $t_{PLH(in/out)}$                          | –       | 60      | 100    | ns            |

## SOFT-START SECTION

|   |              |     |     |    |               |
|---|--------------|-----|-----|----|---------------|
| Charge Current ( $V_{Soft-Start} = 0.5\text{ V}$ )    | $I_{chg}$    | 3.0 | 9.0 | 20 | $\mu\text{A}$ |
| Discharge Current ( $V_{Soft-Start} = 1.5\text{ V}$ ) | $I_{dischg}$ | 1.0 | 4.0 | –  | mA            |

## CURRENT SENSE SECTION

|  |                      |             |             |              |               |
|--|----------------------|-------------|-------------|--------------|---------------|
| Input Bias Current (Pin 9(12) = 0 V to 4.0 V)                                    | $I_{IB}$             | –           | –           | 15           | $\mu\text{A}$ |
| Current Limit Comparator Threshold<br>Shutdown Comparator Threshold              | $V_{th}$<br>$V_{th}$ | 0.9<br>1.25 | 1.0<br>1.40 | 1.10<br>1.55 | V             |
| Propagation Delay (Current Limit/Shutdown to Output, $T_J = +25^\circ\text{C}$ ) | $t_{PLH(in/out)}$    | –           | 50          | 80           | ns            |

## OUTPUT SECTION

|   |                      |               |                           |                      |               |
|---|----------------------|---------------|---------------------------|----------------------|---------------|
| Output Voltage<br>Low State<br><br>High State   | $V_{OL}$<br>$V_{OH}$ | –<br>13<br>12 | 0.25<br>1.2<br>13.5<br>13 | 0.4<br>2.2<br>–<br>– | V             |
| Output Voltage with UVLO Activated ( $V_{CC} = 6.0\text{ V}$ , $I_{Sink} = 0.5\text{ mA}$ ) | $V_{OL(UVLO)}$       | –             | 0.25                      | 1.0                  | V             |
| Output Leakage Current ( $V_C = 20\text{ V}$ )  | $I_L$                | –             | 100                       | 500                  | $\mu\text{A}$ |
| Output Voltage Rise Time ( $C_L = 1.0\text{ nF}$ , $T_J = +25^\circ\text{C}$ )              | $t_r$                | –             | 30                        | 60                   | ns            |
| Output Voltage Fall Time ( $C_L = 1.0\text{ nF}$ , $T_J = +25^\circ\text{C}$ )              | $t_f$                | –             | 30                        | 60                   | ns            |

## UNDERVOLTAGE LOCKOUT SECTION

|  |              |     |     |     |   |
|--|--------------|-----|-----|-----|---|
| Startup Threshold ( $V_{CC}$ Increasing)                     | $V_{th(on)}$ | 8.8 | 9.2 | 9.6 | V |
| UVLO Hysteresis Voltage ( $V_{CC}$ Decreasing After Turn-On) | $V_H$        | 0.4 | 0.8 | 1.2 | V |

## TOTAL DEVICE

|  |          |        |           |           |    |
|--|----------|--------|-----------|-----------|----|
| Power Supply Current<br>Startup ( $V_{CC} = 8.0\text{ V}$ )<br>Operating | $I_{CC}$ | –<br>– | 0.5<br>25 | 1.2<br>35 | mA |
|--|----------|--------|-----------|-----------|----|

- Maximum package power dissipation limits must be observed.
- Low duty cycle pulse techniques are used during test to maintain junction temperature as close to ambient as possible.  
 $T_{low} = 0^\circ\text{C}$  for MC34025       $T_{high} = +70^\circ\text{C}$  for MC34025  
 $= -40^\circ\text{C}$  for MC33025       $= +105^\circ\text{C}$  for MC33025

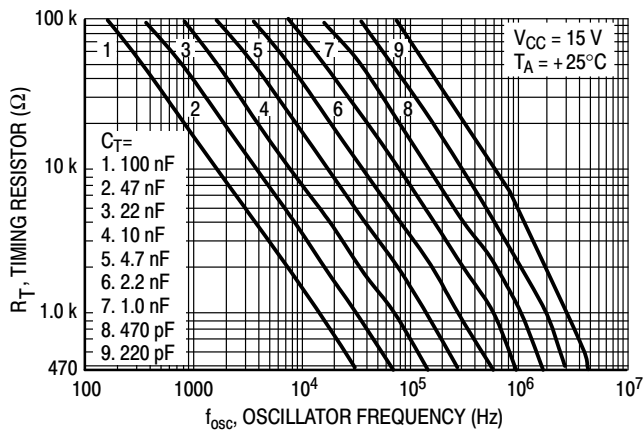


Figure 2. Timing Resistor versus Oscillator Frequency

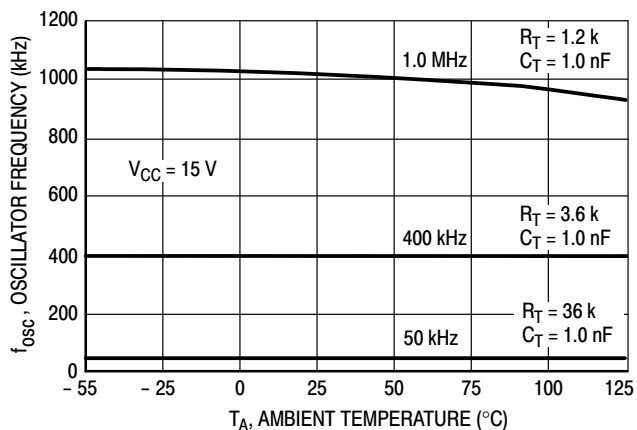


Figure 3. Oscillator Frequency versus Temperature

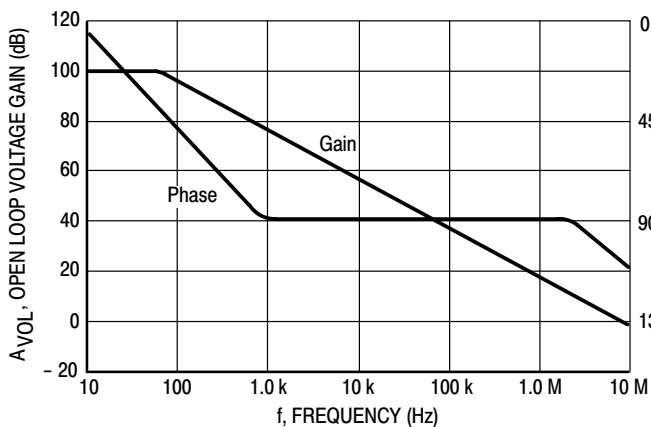


Figure 4. Error Amp Open Loop Gain and Phase versus Frequency

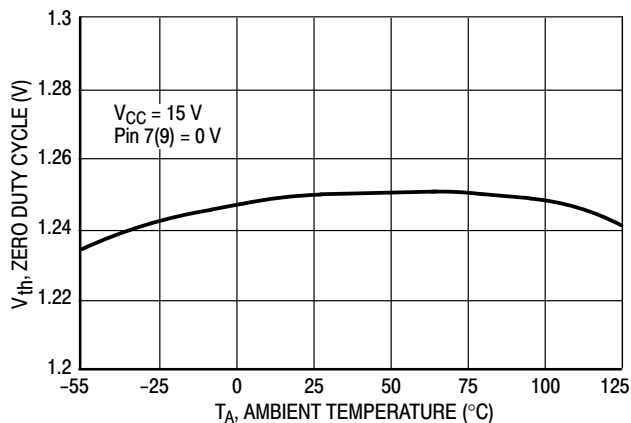


Figure 5. PWM Comparator Zero Duty Cycle Threshold Voltage versus Temperature

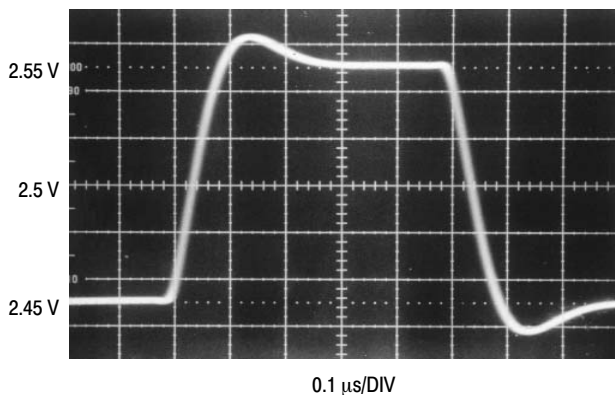


Figure 6. Error Amp Small Signal Transient Response

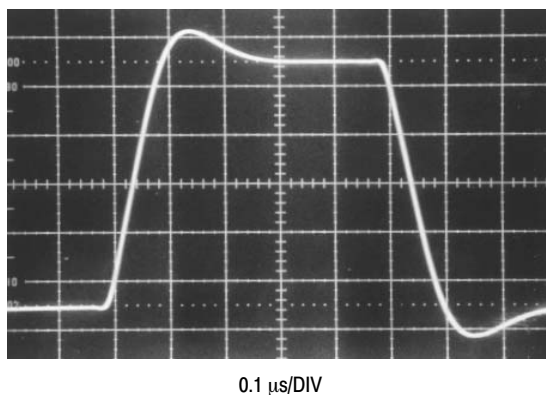
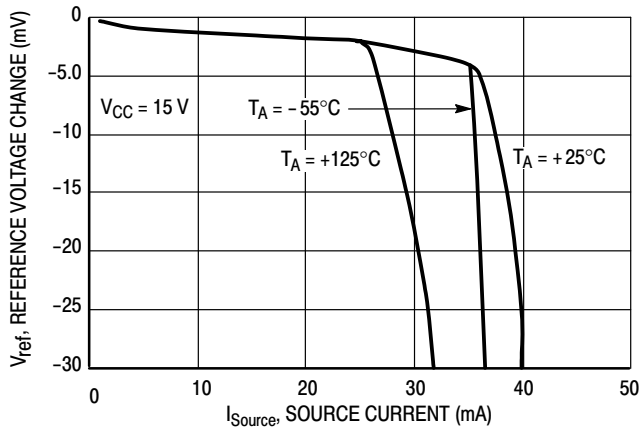
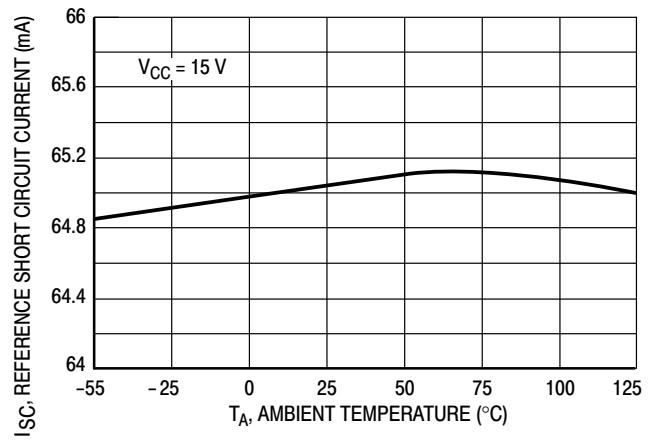


Figure 7. Error Amp Large Signal Transient Response

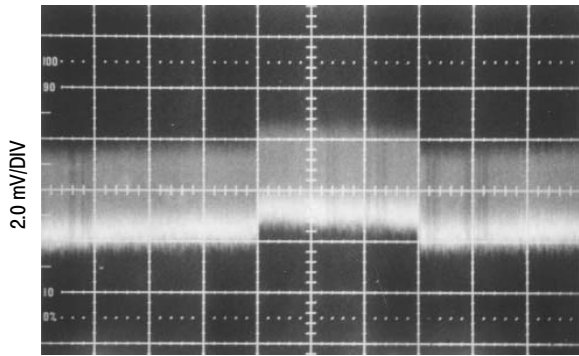
# MC34025, MC33025



**Figure 8. Reference Voltage Change versus Source Current**

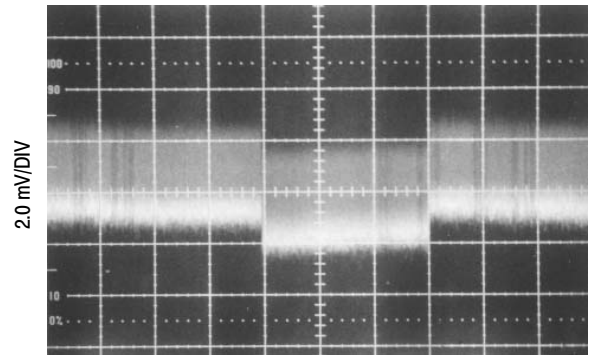


**Figure 9. Reference Short Circuit Current versus Temperature**



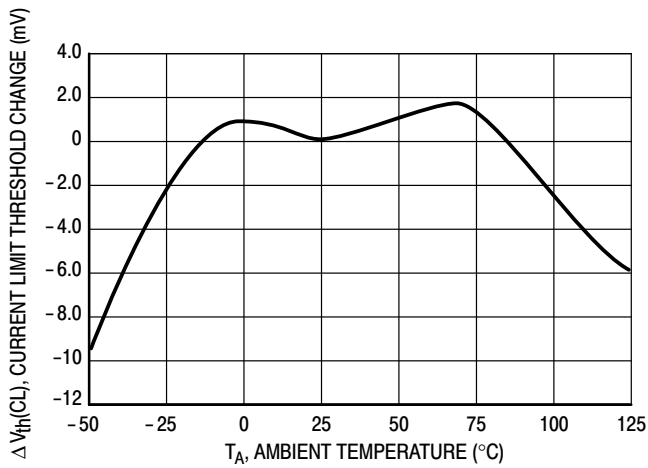
$V_{ref}$  LINE REGULATION 10 V - 24 V  
2.0 ms/DIV

**Figure 10. Reference Line Regulation**

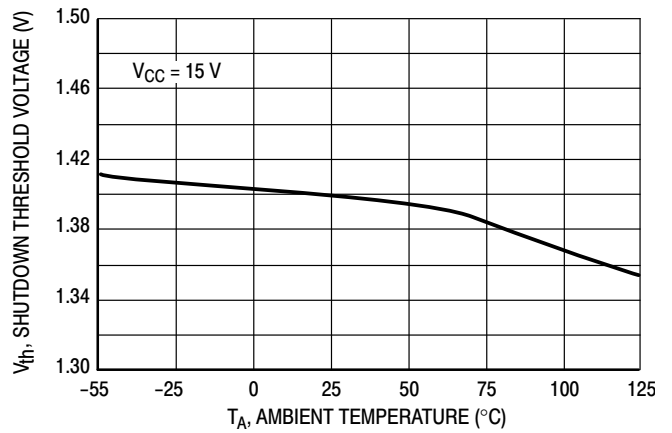


$V_{ref}$  LINE REGULATION 1.0 mA - 10 mA  
2.0 ms/DIV

**Figure 11. Reference Load Regulation**



**Figure 12. Current Limit Comparator Threshold Change versus Temperature**



**Figure 13. Shutdown Comparator Threshold Voltage versus Temperature**

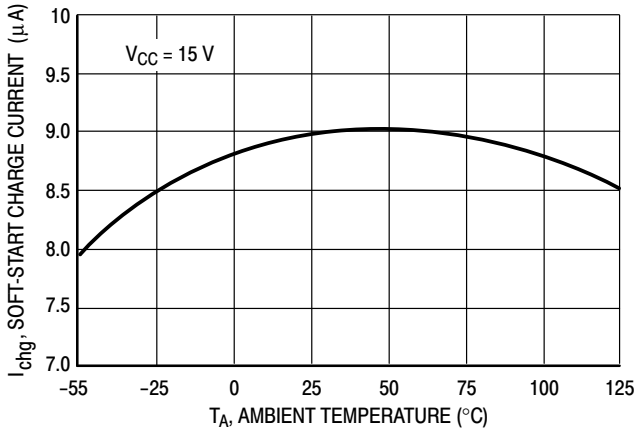


Figure 14. Soft-Start Charge Current versus Temperature

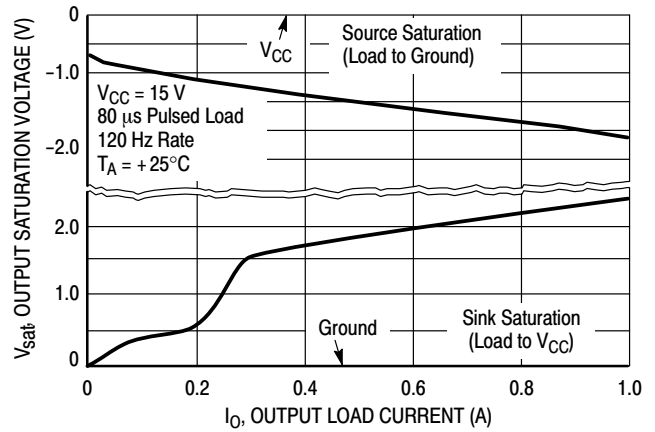
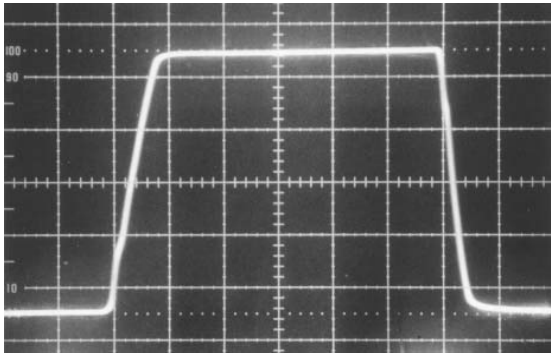
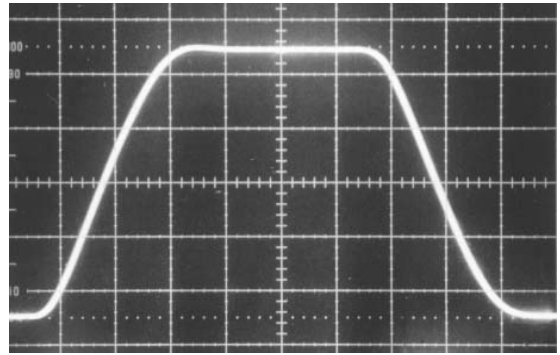


Figure 15. Output Saturation Voltage versus Load Current



OUTPUT RISE & FALL TIME 1.0 nF LOAD  
50 ns/DIV

Figure 16. Drive Output Rise and Fall Time



OUTPUT RISE & FALL TIME 10.0 nF LOAD  
50 ns/DIV

Figure 17. Drive Output Rise and Fall Time

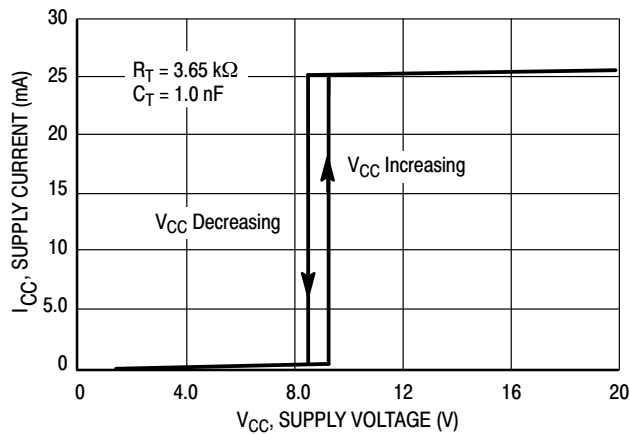
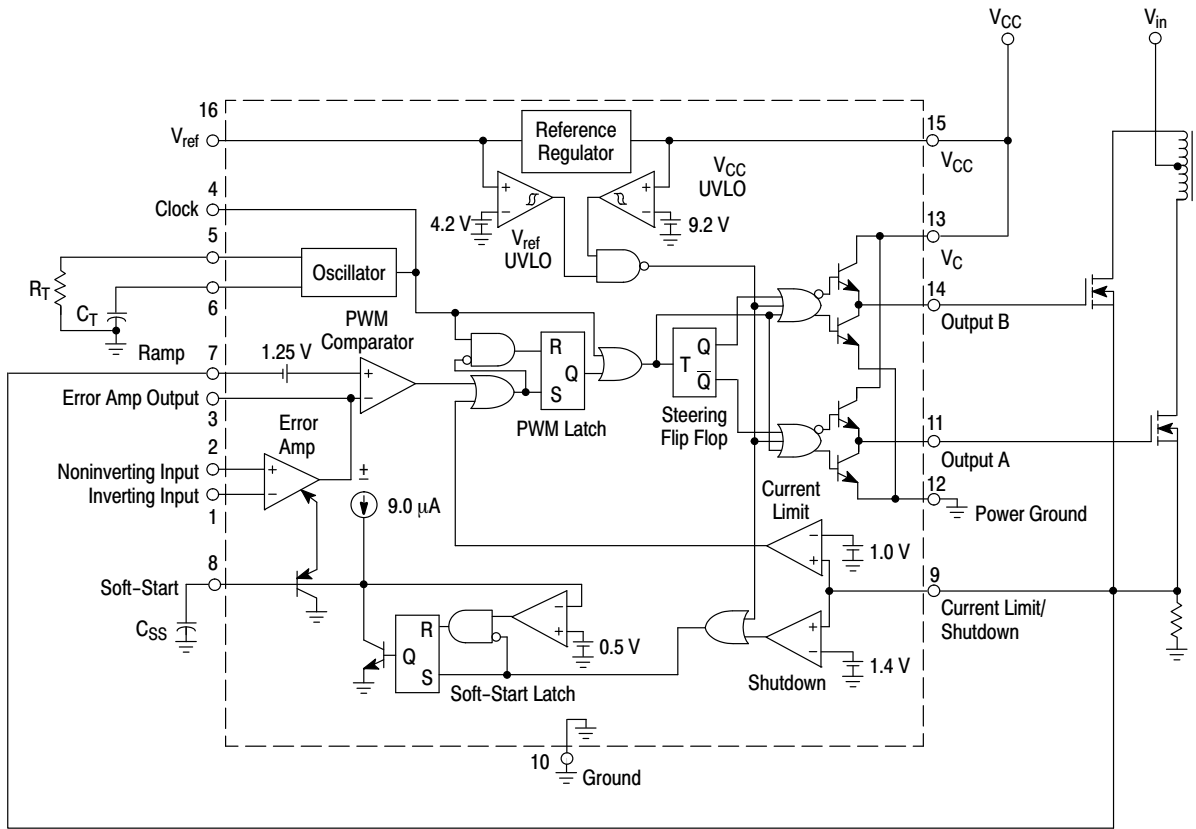
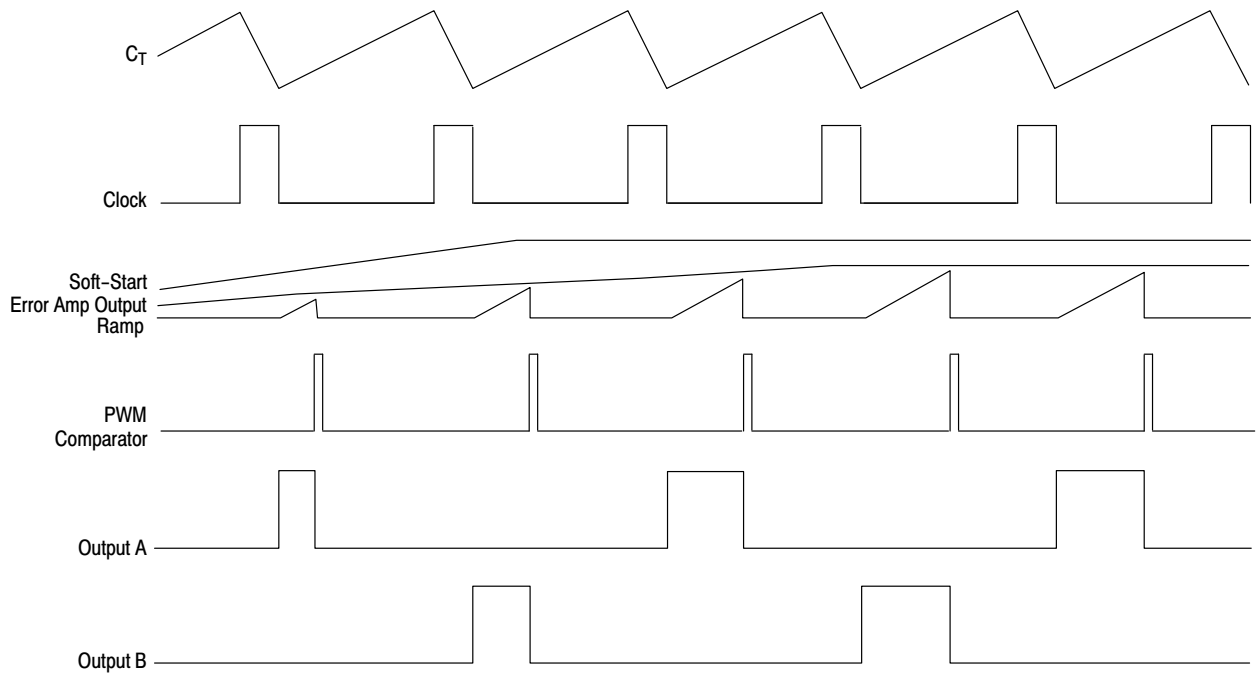


Figure 18. Supply Voltage versus Supply Current

**MC34025, MC33025**



**Figure 19. Representative Block Diagram**



**Figure 20. Current Limit Operating Waveforms**

## OPERATING DESCRIPTION

The MC33025 and MC34025 series are high speed, fixed frequency, double-ended pulse width modulator controllers optimized for high frequency operation. They are specifically designed for Off-Line and DC-to-DC converter applications offering the designer a cost effective solution with minimal external components. A representative block diagram is shown in Figure 19.

**Oscillator**

The oscillator frequency is programmed by the values selected for the timing components  $R_T$  and  $C_T$ . The  $R_T$  pin is set to a temperature compensated 3.0 V. By selecting the value of  $R_T$ , the charge current is set through a current mirror for the timing capacitor  $C_T$ . This charge current runs continuously through  $C_T$ . The discharge current ratio is to be 10 times the charge current, which yields the maximum duty cycle of 90%.  $C_T$  is charged to 2.8 V and discharged to 1.0 V. During the discharge of  $C_T$ , the oscillator generates an internal blanking pulse that resets the PWM Latch, inhibits the outputs, and toggles the steering flip-flop. The threshold voltages on the oscillator comparator is trimmed to guarantee an oscillator accuracy of 5.0% at 25°C.

Additional dead time can be added by externally increasing the charge current to  $C_T$  as shown in Figure 24. This changes the charge to discharge ratio of  $C_T$  which is set internally to  $I_{\text{charge}}/10 I_{\text{charge}}$ . The new charge to discharge ratio will be:

$$\% \text{ Deadtime} = \frac{I_{\text{additional}} + I_{\text{charge}}}{10 (I_{\text{charge}})}$$

A bidirectional clock pin is provided for synchronization or for master/slave operation. As a master, the clock pin provides a positive output pulse during the discharge of  $C_T$ . As a slave, the clock pin is an input that resets the PWM latch and blanks the drive output, but does not discharge  $C_T$ . Therefore, the oscillator is not synchronized by driving the clock pin alone. Figures 30 and 31 provide suggested synchronization.

**Error Amplifier**

A fully compensated Error Amplifier is provided. It features a typical DC voltage gain of 95 dB and a gain bandwidth product of 8.3 MHz with 75 degrees of phase margin (Figure 4). Typical application circuits will have the noninverting input tied to the reference. The inverting input will typically be connected to a feedback voltage generated from the output of the switching power supply. Both inputs have a Common Mode Voltage ( $V_{\text{CM}}$ ) input range of 1.5 V to 5.5 V. The Error Amplifier Output is provided for external loop compensation.

**Soft-Start Latch**

Soft-Start is accomplished in conjunction with an external capacitor. The soft start capacitor is charged by an internal 9.0  $\mu\text{A}$  current source. This capacitor clamps the output of the error amplifier to less than its normal output voltage, thus limiting the duty cycle.

The time it takes for a capacitor to reach full charge is given by:

$$t \approx (4.5 \cdot 10^5) C_{\text{Soft-Start}}$$

A Soft-Start latch is incorporated to prevent erratic operation of this circuitry. Two conditions can cause the Soft-Start circuit to latch so that the Soft-Start capacitor stays discharged. The first condition is activation of an undervoltage lockout of either  $V_{\text{CC}}$  or  $V_{\text{ref}}$ . The second condition is when current sense input exceeds 1.4 V. Since this latch is "set dominant", it cannot be reset until either of these signals is removed, and the voltage at  $C_{\text{Soft-Start}}$  is less than 0.5 V.

**PWM Comparator and Latch**

A PWM circuit typically compares an error voltage with a ramp signal. The outcome of this comparison determines the state of the output. In voltage mode operation the ramp signal is the voltage ramp of the timing capacitor. In current mode operation the ramp signal is the voltage ramp induced in a current sensing element. The ramp input of the PWM comparator is pinned out so that the user can decide which mode of operation best suits the application requirements. The ramp input has a 1.25 V offset such that whenever the voltage at this pin exceeds the Error Amplifier Output voltage minus 1.25 V, the PWM comparator will cause the PWM latch to set, disabling the outputs. Once the PWM latch is set, only a blanking pulse by the oscillator can reset it, thus initiating the next cycle.

A toggle flip flop connected to the output of the PWM latch controls which output is active. The flip flop is pulsed by an OR gate that gets its inputs from the oscillator clock and the output of the PWM latch. A pulse from either one will cause the flip flop to enable the other output.

**Current Limiting and Shutdown**

A pin is provided to perform current limiting and shutdown operations. Two comparators are connected to the input of this pin. When the voltage at this pin exceeds 1.0 V, one of the comparators is activated. The output of this comparator sets the PWM latch, which disables the output. In this way cycle-by-cycle current limiting is accomplished. If a current limit resistor is used in series with the power devices, the value of the resistor is found by:

$$R_{\text{Sense}} = \frac{1.0 \text{ V}}{I_{\text{pk (switch)}}$$

If the voltage at this pin exceeds 1.4 V, the second comparator is activated. This comparator sets a latch which, in turn, causes the Soft-Start capacitor to be discharged. In this way a “hiccup” mode of recovery is possible in the case of output short circuits. If a current limit resistor is used in series with the output devices, the peak current at which the controller will enter a “hiccup” mode is given by:

$$I_{\text{shutdown}} = \frac{1.4 \text{ V}}{R_{\text{Sense}}}$$

### Undervoltage Lockout

There are two undervoltage lockout circuits within the IC. The first senses  $V_{CC}$  and the second  $V_{\text{ref}}$ . During power-up,  $V_{CC}$  must exceed 9.2 V and  $V_{\text{ref}}$  must exceed 4.2 V before the outputs can be enabled and the Soft-Start latch released. If  $V_{CC}$  falls below 8.4 V or  $V_{\text{ref}}$  falls below 3.6 V, the outputs are disabled and the Soft-Start latch is activated. When the UVLO is active, the part is in a low current standby mode allowing the IC to have an off-line bootstrap startup circuit. Typical startup current is 500  $\mu\text{A}$ .

### Output

The MC34025 has two high current totem pole outputs specifically designed for direct drive of power MOSFETs. They are capable of up to  $\pm 2.0$  A peak drive current with a typical rise and fall time of 30 ns driving a 1.0 nF load.

Separate pins for  $V_C$  and Power Ground are provided. With proper implementation, a significant reduction of switching transient noise imposed on the control circuitry is possible. The separate  $V_C$  supply input also allows the designer added flexibility in tailoring the drive voltage independent of  $V_{CC}$ .

### Reference

A 5.1 V bandgap reference is pinned out and is trimmed to an initial accuracy of  $\pm 1.0\%$  at 25°C. This reference has short circuit protection and can source in excess of 10 mA for powering additional control system circuitry.

### Design Considerations

**Do not attempt to construct the converter on wire-wrap or plug-in prototype boards.** With high frequency, high power, switching power supplies it is imperative to have separate current loops for the signal paths and for the power paths. The printed circuit layout should contain a ground plane with low current signal and high current switch and output grounds returning on separate

paths back to the input filter capacitor. All bypass capacitors and snubbers should be connected as close as possible to the specific part in question. The PC board lead lengths must be less than 0.5 inches for effective bypassing or snubbing.

### Instabilities

In current mode control, an instability can be encountered at any given duty cycle. The instability is caused by the current feedback loop. It has been shown that the instability is caused by a double pole at half the switching frequency. If an external ramp ( $S_e$ ) is added to the on-time ramp ( $S_n$ ) of the current-sense waveform, stability can be achieved (see Figure 21).

One must be careful not to add too much ramp compensation. If too much is added, the system will start to perform like a voltage mode regulator. All benefits of current mode control will be lost. Figures 29A and 29B show examples of two different ways in which external ramp compensation can be implemented.

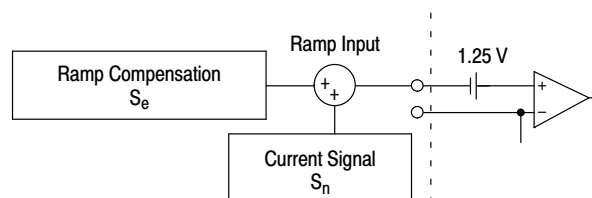


Figure 21. Ramp Compensation

A simple equation can be used to calculate the amount of external ramp necessary to add that will achieve stability in the current loop. For the following equations, the calculated values for the application circuit in Figure 37 are also shown.

$$S_e = \frac{V_O}{L} \left( \frac{N_S}{N_P} \right) (R_S) A_i$$

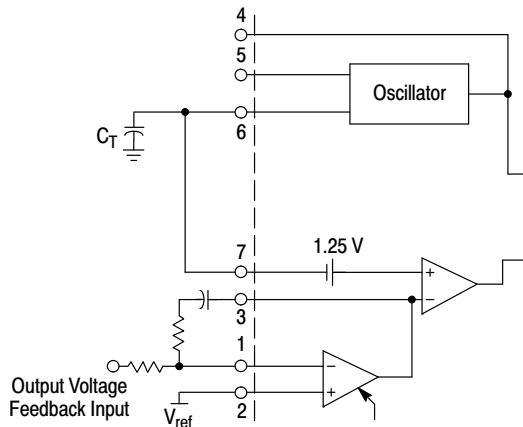
- where:
- $V_O$  = DC output voltage
  - $N_P, N_S$  = number of power transformer primary or secondary turns
  - $A_i$  = gain of the current sense network (see Figures 26, 27 and 28)
  - $L$  = output inductor
  - $R_S$  = current sense resistance

For the application circuit:  $S_e = \frac{5}{1.8 \mu} \left( \frac{4}{16} \right) (0.3) (0.55) = 0.115 \text{ V}/\mu\text{s}$

# MC34025, MC33025

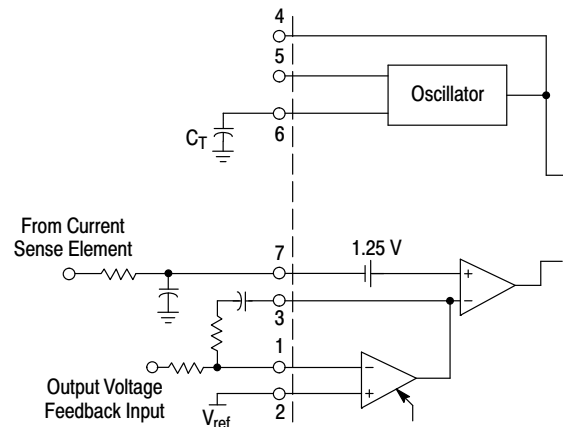
## PIN FUNCTION DESCRIPTION

| Pin No. | Function                     | Description  |
|---------|------------------------------|--|
| 1       | Error Amp Inverting Input    | This pin is usually used for feedback from the output of the power supply.   |
| 2       | Error Amp Noninverting Input | This pin is used to provide a reference in which an error signal can be produced on the output of the error amp. Usually this is connected to $V_{ref}$ , however an external reference can also be used.                              |
| 3       | Error Amp Output             | This pin is provided for compensating the error amp for poles and zeros encountered in the power supply system, mostly the output LC filter.   |
| 4       | Clock                        | This is a bidirectional pin used for synchronization.  |
| 5       | $R_T$                        | The value of $R_T$ sets the charge current through timing Capacitor, $C_T$ .   |
| 6       | $C_T$                        | In conjunction with $R_T$ , the timing Capacitor sets the switching frequency. Because this part is a push-pull output, each output runs at one-half the frequency set at this pin.  |
| 7       | Ramp Input                   | For voltage mode operation this pin is connected to $C_T$ . For current mode operation this pin is connected through a filter to the current sensing element.  |
| 8       | Soft-Start                   | A capacitor at this pin sets the Soft-Start time.  |
| 9       | Current Limit/Shutdown       | This pin has two functions. First, it provides cycle-by-cycle current limiting. Second, if the current is excessive, this pin will reinitiate a Soft-Start cycle.  |
| 10      | Ground                       | This pin is the ground for the control circuitry.  |
| 11      | Output A                     | This is a high current totem pole output.  |
| 12      | Power Ground                 | This is a separate power ground return that is connected back to the power source. It is used to reduce the effects of switching transient noise on the control circuitry.   |
| 13      | $V_C$                        | This is a separate power source connection for the outputs that is connected back to the power source input. With a separate power source connection, it can reduce the effects of switching transient noise on the control circuitry. |
| 14      | Output B                     | This is a high current totem pole output.  |
| 15      | $V_{CC}$                     | This pin is the positive supply of the control IC.   |
| 16      | $V_{ref}$                    | This is a 5.1 V reference. It is usually connected to the noninverting input of the error amplifier.   |



In voltage mode operation, the control range on the output of the Error Amplifier from 0% to 90% duty cycle is from 2.25 V to 4.05 V.

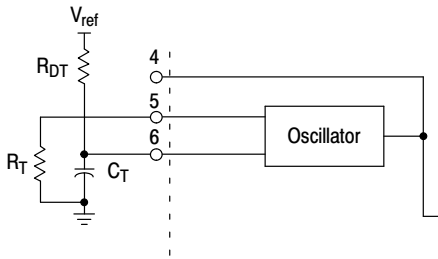
**Figure 22. Voltage Mode Operation**



In current mode control, an RC filter should be placed at the ramp input to filter the leading edge spike caused by turn-on of a power MOSFET.

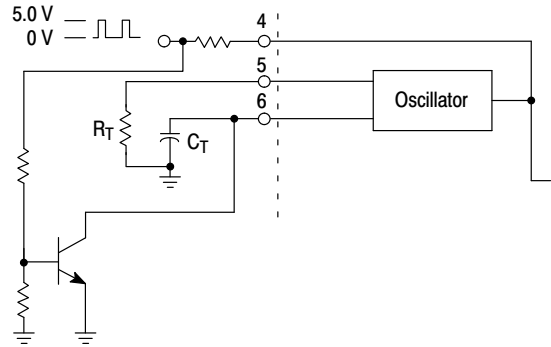
**Figure 23. Current Mode Operation**

# MC34025, MC33025



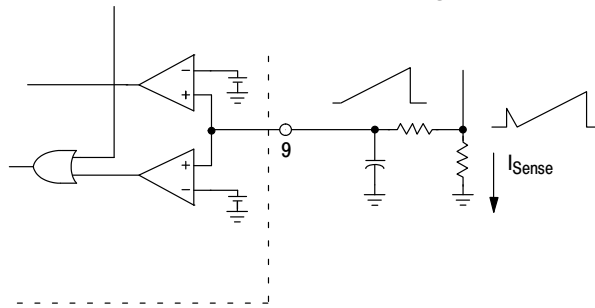
Additional dead time can be added by the addition of a dead time resistor from  $V_{ref}$  to  $C_T$ . See text on oscillator section for more information.

**Figure 24. Dead Time Addition**



The sync pulse fed into the clock pin must be at least 3.9 V.  $R_T$  and  $C_T$  need to be set 10% slower than the sync frequency. This circuit is also used in voltage mode operation for master/slave operation. The clock signal would be coming from the master which is set at the desired operating frequency, while the slave is set 10% slower.

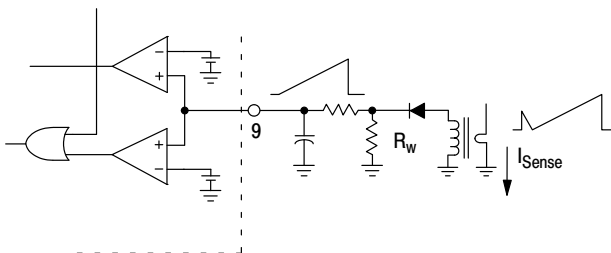
**Figure 25. External Clock Synchronization**



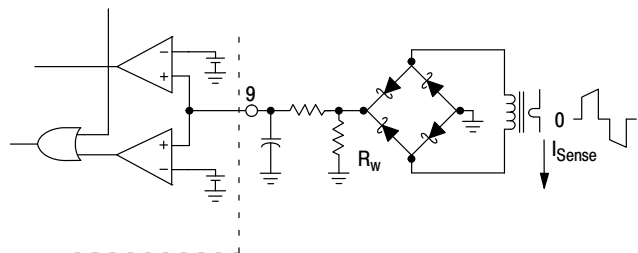
The addition of an RC filter will eliminate instability caused by the leading edge spike on the current waveform. This sense signal can also be used at the ramp input pin for current mode control. For ramp compensation it is necessary to know the gain of the current feedback loop. If a transformer is used, the gain can be calculated by:

$$A_i = \frac{R_{Sense}}{\text{turns ratio}}$$

**Figure 26. Resistive Current Sensing**



**Figure 27. Primary Side Current Sensing**

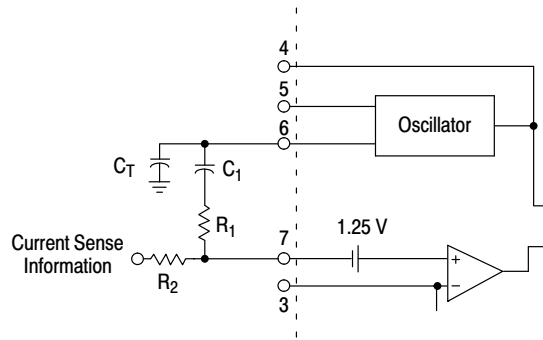


**Figure 28. Primary or Secondary Side Current Sensing**

The addition of an RC filter will eliminate instability caused by the leading edge spike on the current waveform. This sense signal can also be used at the ramp input pin for current mode control. For ramp compensation it is necessary to know the gain of the current feedback loop. The gain can be calculated by:

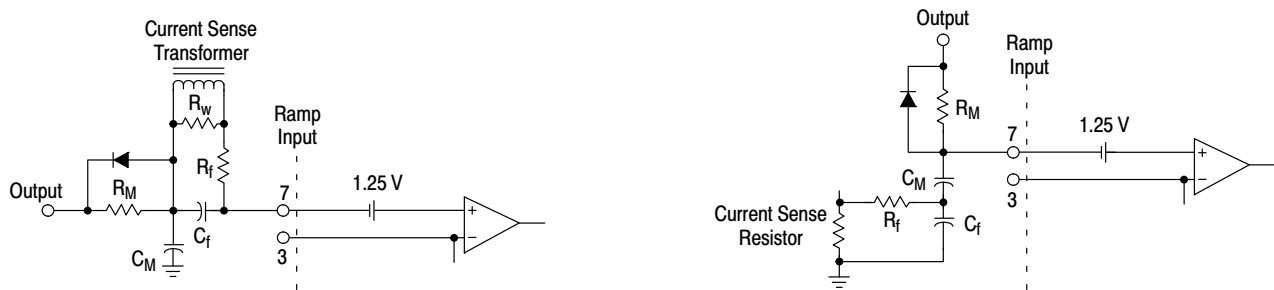
$$A_i = \frac{R_w}{\text{turns ratio}}$$

## MC34025, MC33025



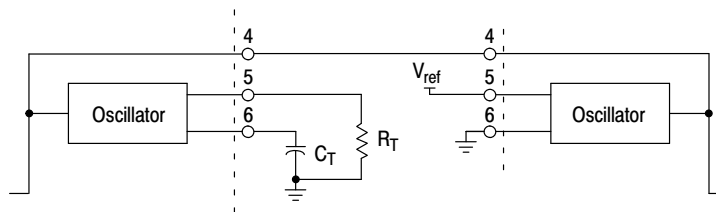
This method of slope compensation is easy to implement, however, it is noise sensitive. Capacitor  $C_1$  provides AC coupling. The oscillator signal is added to the current signal by a voltage divider consisting of resistors  $R_1$  and  $R_2$ .

**Figure 29A. Slope Compensation (Noise Sensitive)**



When only one output is used, this method of slope compensation can be used and it is relatively noise immune. Resistor  $R_M$  and capacitor  $C_M$  provide the added slope necessary. By choosing  $R_M$  and  $C_M$  with a larger time constant than the switching frequency, you can assume that its charge is linear. First choose  $C_M$ , then  $R_M$  can be adjusted to achieve the required slope. The diode provides a reset pulse at the end of every cycle. The charge current  $I_M$  can be calculated by  $I_M = C_M S_e$ . Then  $R_M$  can be calculated by  $R_M = V_{CC}/I_M$ .

**Figure 29B. Slope Compensation (Noise Immune)**



**Figure 30. Current Mode Master/Slave Operation Over Short Distances**

# MC34025, MC33025

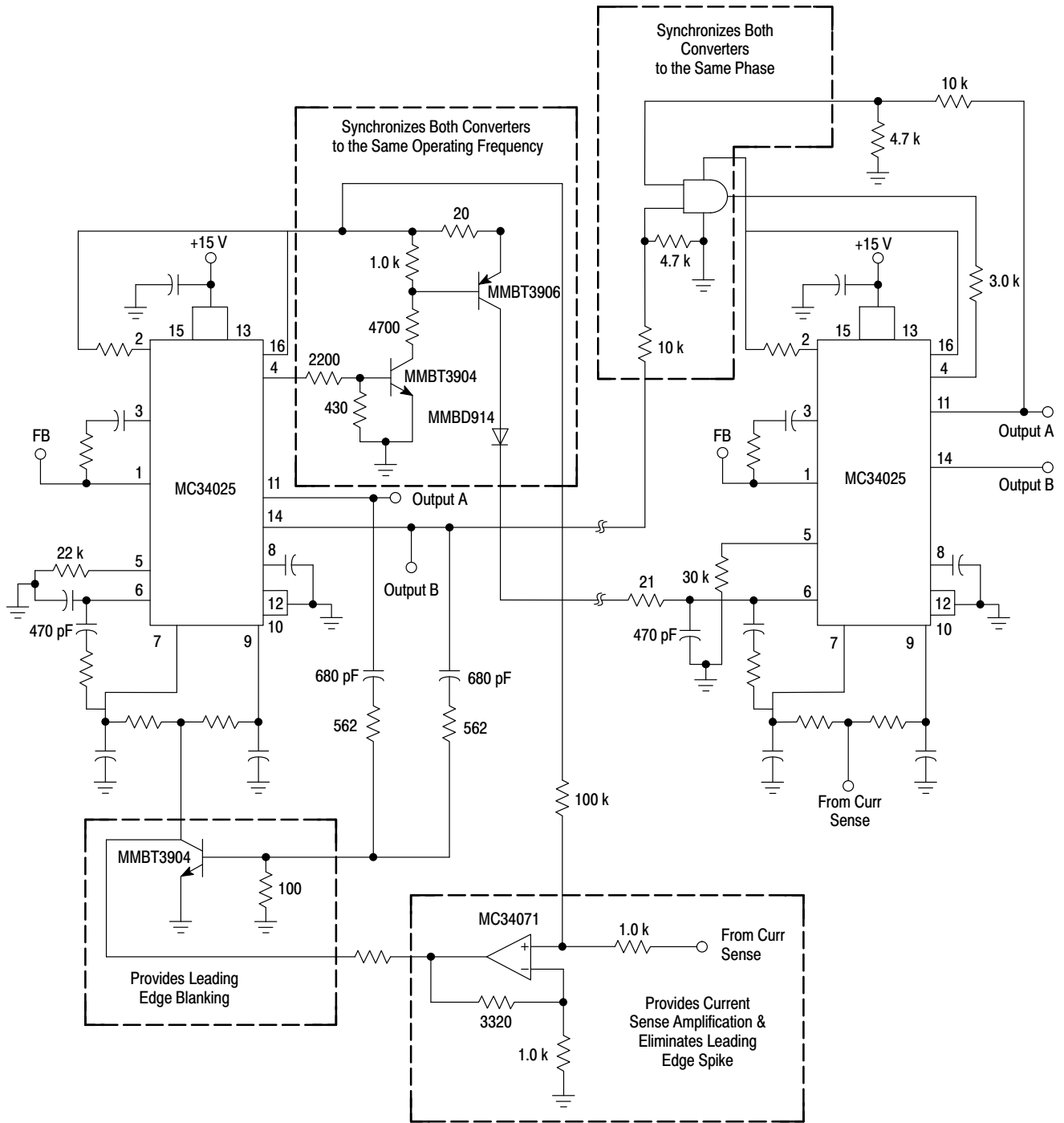
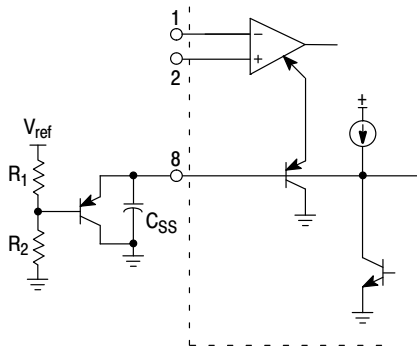


Figure 31. Synchronization Over Long Distances

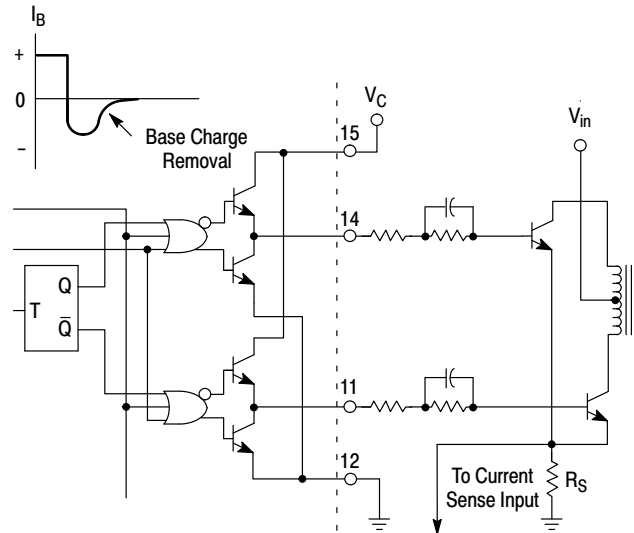


In voltage mode operation, the maximum duty cycle can be clamped. By the addition of a PNP transistor to buffer the clamp voltage, the Soft-Start current is not affected by R<sub>1</sub>.

$$\text{The new equation for Soft-Start is } t \approx \frac{V_{\text{clamp}} + 0.6}{9.0 \mu\text{A}} (C_{\text{SS}})$$

In current mode operation, this circuit will limit the maximum voltage allowed at the ramp input to end a cycle.

Figure 32. Buffered Maximum Clamp Level



The totem pole output can furnish negative base current for enhanced transistor turn-off, with the addition of the capacitor in series with the base.

Figure 33. Bipolar Transistor Drive

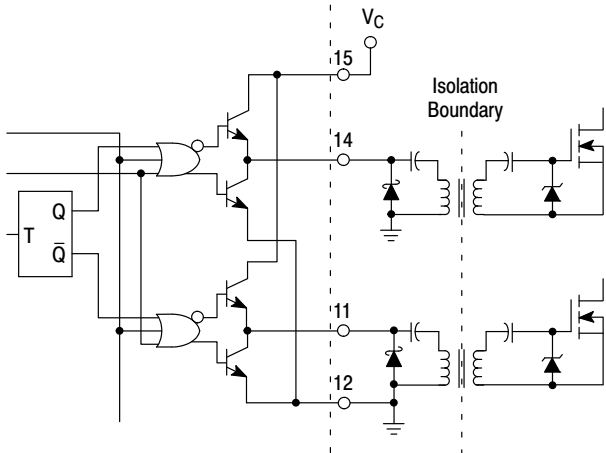


Figure 34. Isolated MOSFET Drive

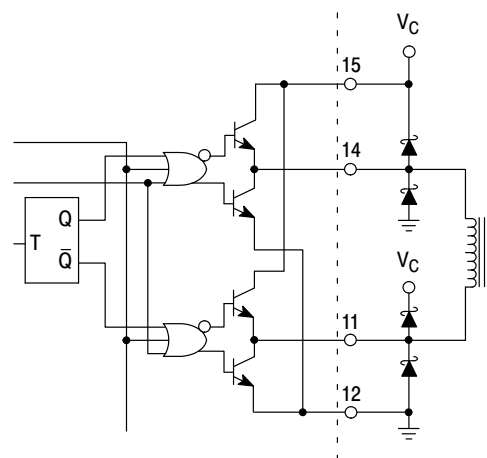


Figure 35. Direct Transformer Drive

The totem pole output can easily drive pulse transformers. A Schottky diode is recommended when driving inductive loads at high frequencies. The diode can reduce the driver's power dissipation due to excessive ringing, by preventing the output pin from being driven below ground.

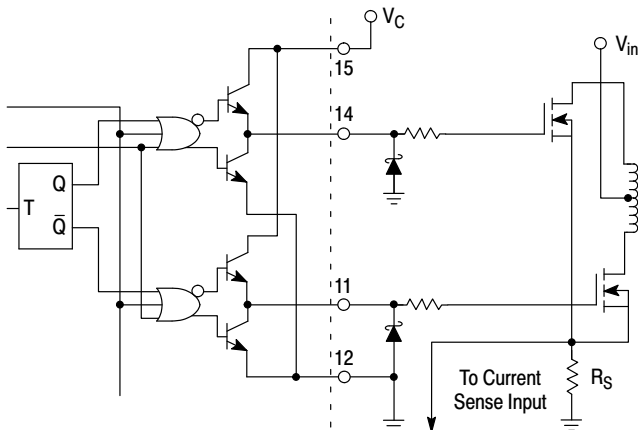
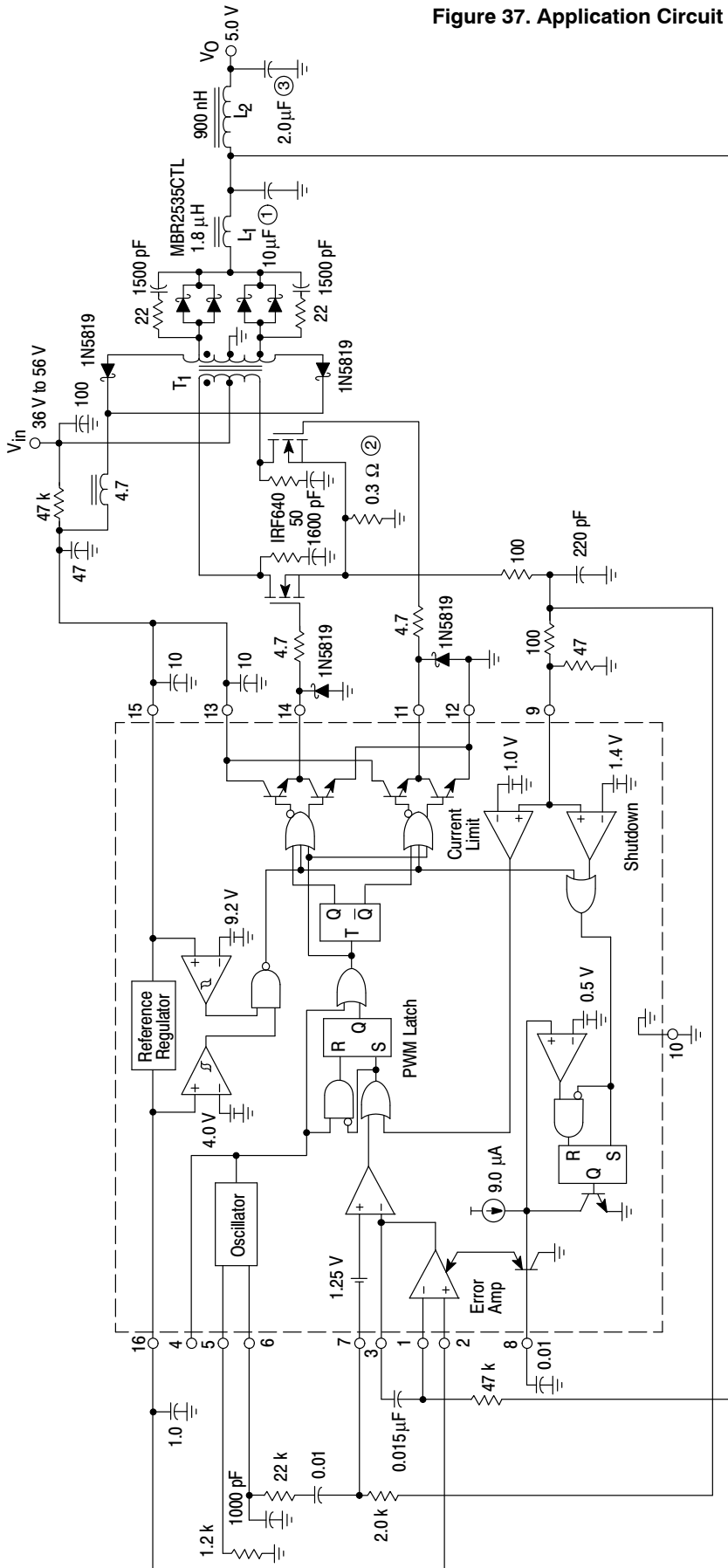


Figure 36. MOSFET Parasitic Oscillations

A series gate resistor may be needed to damp high frequency parasitic oscillation caused by a MOSFET's input capacitance and any series wiring inductance in the gate-source circuit. The series resistor will also decrease the MOSFET's switching speed. A Schottky diode can reduce the driver's power dissipation due to excessive ringing, by preventing the output pin from being driven below ground. The Schottky diode also prevents substrate injection when the output pin is driven below ground.

Figure 37. Application Circuit



$T_1$  - Primary: 16 turns center tapped #48 AWG (1300 strands litz wire)  
 Secondary: 4 turns center tapped 0.003" (2 layers) copper foil  
 Bootstrap: 1 turn added to each secondary output #36 AWG  
 Core: Phillips 9F3, part #4312 020 4124  
 Bobbin: Phillips part #4322 021 3525  
 Coilcraft P3269-A

$L_1$  - 2 turns #48 AWG (1300 strands litz wire)  
 Core: Phillips 9F3, part #EP10-9F3  
 Bobbin: Phillips part #EP10PCB1-8  
 L = 1.8  $\mu$ H  
 Coilcraft P3270-A

$L_2$  - 7 turns #18 AWG, 1/2" diameter air core  
 Coilcraft P3271-A

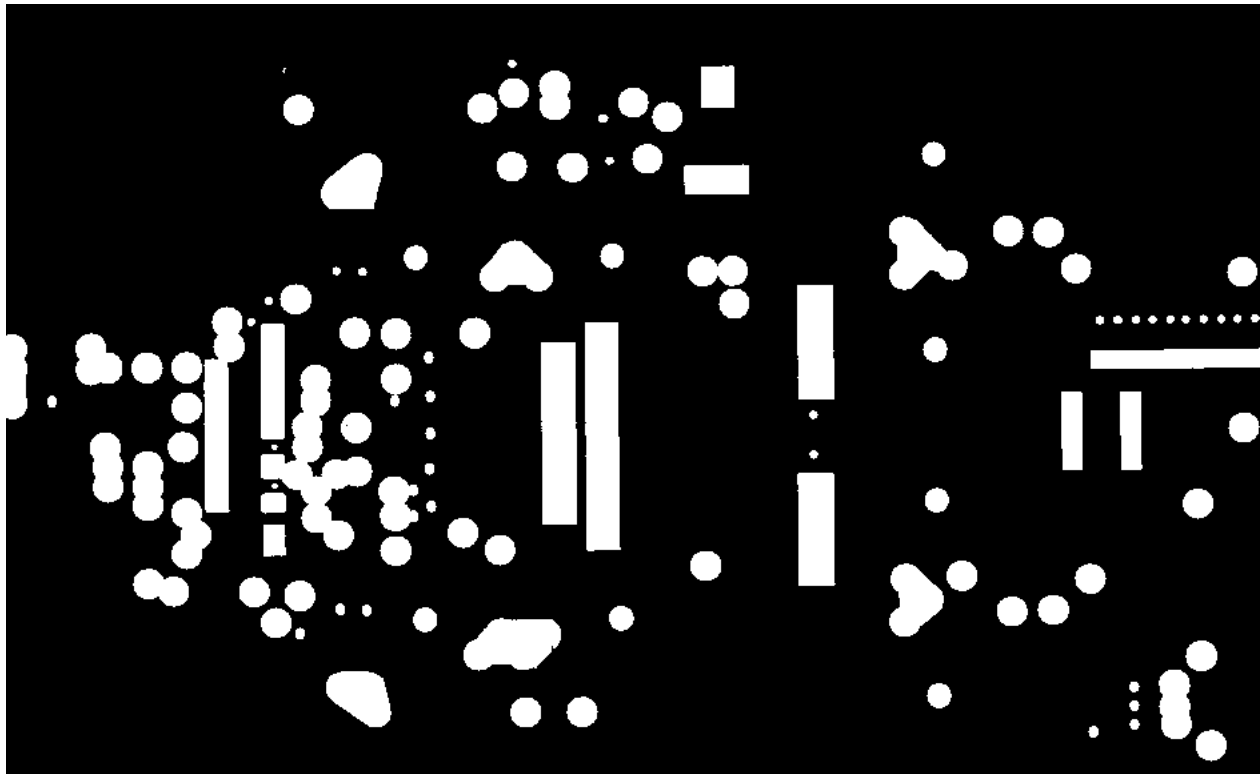
Heatsinks - Power FET: AAVID Heatsink #533902B02554 with clip  
 Output Rectifiers: AAVID Heatsink #533402B02552 with clip

Insulators - All power devices are insulated with Berquist Sil-Pad 1500

- ① - 10 (1.0  $\mu$ F) ceramic capacitors in parallel
- ② - 5 (1.5  $\Omega$ ) resistors in parallel
- ③ - 2 (1.0  $\mu$ F) ceramic capacitors in parallel

| Test            | Condition                              | Result                |
|-----------------|--|-----------------------|
| Line Regulation | $V_{in} = 40$ V to 56 V, $I_O = 15$ A  | 14 mV = $\pm 0.275\%$ |
| Load Regulation | $V_{in} = 48$ V, $I_O = 8.0$ V to 15 A | 54 mV = $\pm 1.0\%$   |
| Output Ripple   | $V_{in} = 48$ V, $I_O = 15$ A          | 50 mV/p-p             |
| Efficiency      | $V_{in} = 48$ V, $I_O = 15$ A          | 71.2%                 |





(Top View)

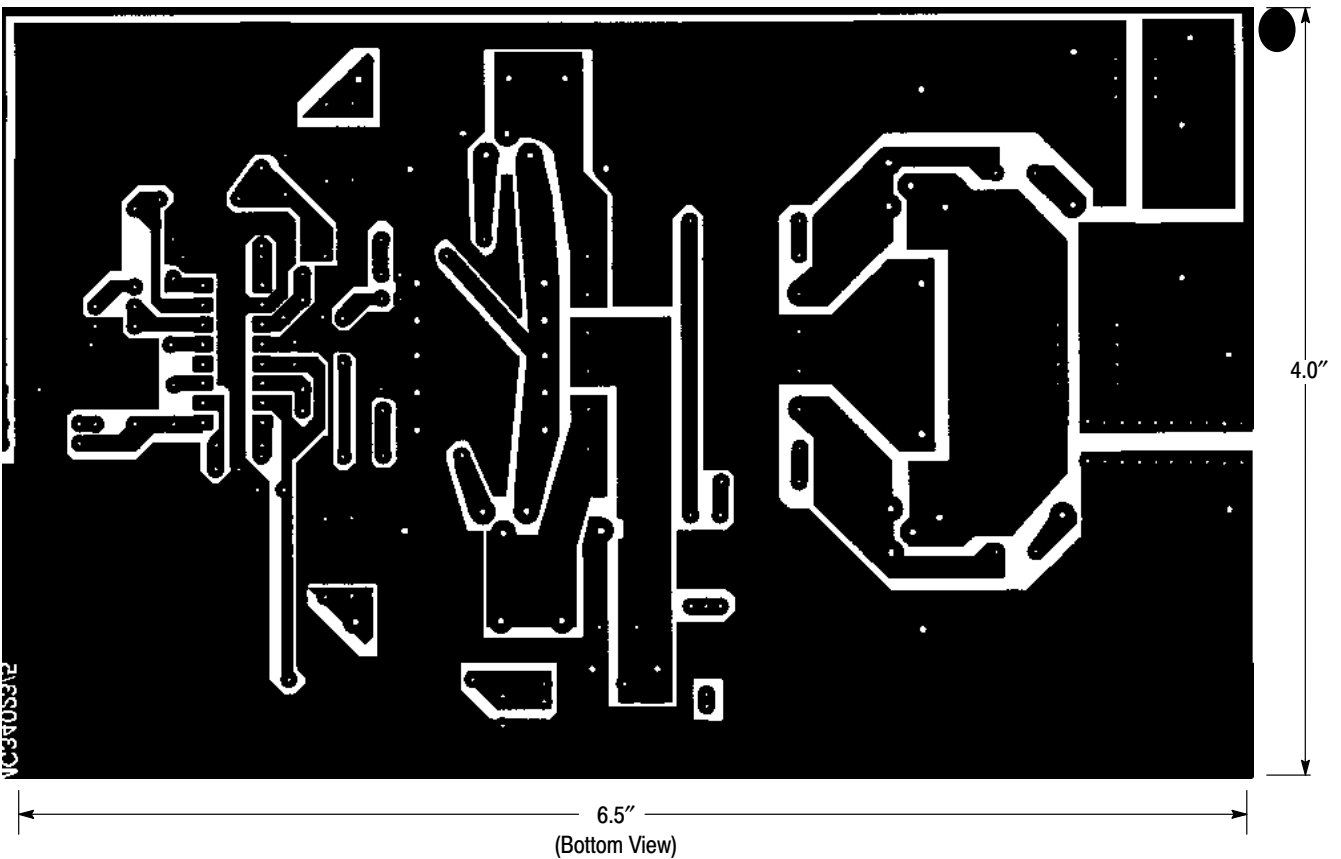


Figure 39. PC Board Without Components

## MC34025, MC33025

### ORDERING INFORMATION

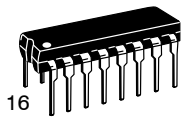
| Device       | Package                | Shipping†                |
|--------------|------------------------|--------------------------|
| MC33025DWG   | SOIC-16WB<br>(Pb-Free) | 47 Units / Rail          |
| MC33025DWR2G | SOIC-16WB<br>(Pb-Free) | 1000 Units / Tape & Reel |
| MC33025PG    | PDIP-16<br>(Pb-Free)   | 25 Units / Rail          |
| MC34025DWG   | SOIC-16WB<br>(Pb-Free) | 47 Units / Rail          |
| MC34025DWR2G | SOIC-16WB<br>(Pb-Free) | 1000 Units / Tape & Reel |
| MC34025PG    | PDIP-16<br>(Pb-Free)   | 25 Units / Rail          |

†For information on tape and reel specifications, including part orientation and tape sizes, please refer to our Tape and Reel Packaging Specifications Brochure, BRD8011/D.

# MECHANICAL CASE OUTLINE

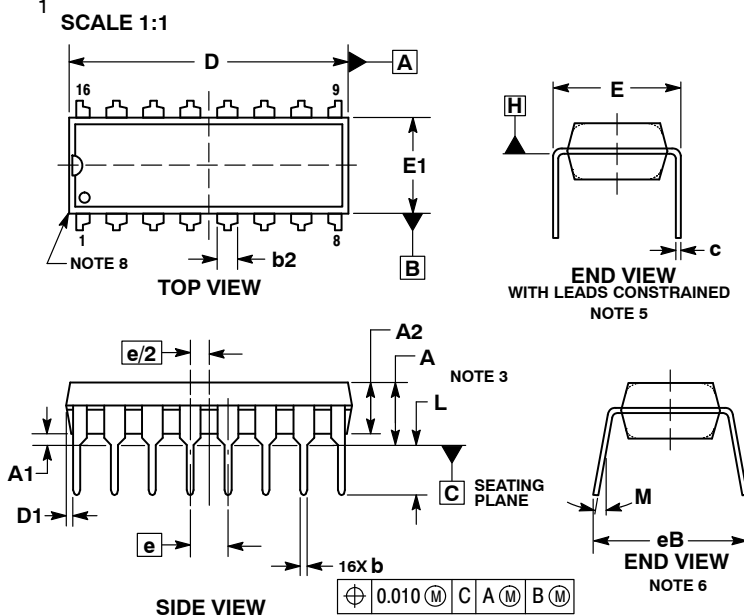
## PACKAGE DIMENSIONS

ON Semiconductor®



### PDIP-16 CASE 648-08 ISSUE V

DATE 22 APR 2015

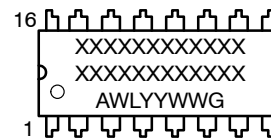


NOTES:

1. DIMENSIONING AND TOLERANCING PER ASME Y14.5M, 1994.
2. CONTROLLING DIMENSION: INCHES.
3. DIMENSIONS A, A1 AND L ARE MEASURED WITH THE PACKAGE SEATED IN JEDEC SEATING PLANE GAUGE GS-3.
4. DIMENSIONS D, D1 AND E1 DO NOT INCLUDE MOLD FLASH OR PROTRUSIONS. MOLD FLASH OR PROTRUSIONS ARE NOT TO EXCEED 0.10 INCH.
5. DIMENSION E IS MEASURED AT A POINT 0.015 BELOW DATUM PLANE H WITH THE LEADS CONSTRAINED PERPENDICULAR TO DATUM C.
6. DIMENSION eB IS MEASURED AT THE LEAD TIPS WITH THE LEADS UNCONSTRAINED.
7. DATUM PLANE H IS COINCIDENT WITH THE BOTTOM OF THE LEADS, WHERE THE LEADS EXIT THE BODY.
8. PACKAGE CONTOUR IS OPTIONAL (ROUNDED OR SQUARE CORNERS).

| DIM | INCHES    |       | MILLIMETERS |       |
|-----|-----------|-------|-------------|-------|
|     | MIN       | MAX   | MIN         | MAX   |
| A   | ---       | 0.210 | ---         | 5.33  |
| A1  | 0.015     | ---   | 0.38        | ---   |
| A2  | 0.115     | 0.195 | 2.92        | 4.95  |
| b   | 0.014     | 0.022 | 0.35        | 0.56  |
| b2  | 0.060 TYP |       | 1.52 TYP    |       |
| C   | 0.008     | 0.014 | 0.20        | 0.36  |
| D   | 0.735     | 0.775 | 18.67       | 19.69 |
| D1  | 0.005     | ---   | 0.13        | ---   |
| E   | 0.300     | 0.325 | 7.62        | 8.26  |
| E1  | 0.240     | 0.280 | 6.10        | 7.11  |
| e   | 0.100 BSC |       | 2.54 BSC    |       |
| eB  | ---       | 0.430 | ---         | 10.92 |
| L   | 0.115     | 0.150 | 2.92        | 3.81  |
| M   | ---       | 10°   | ---         | 10°   |

### GENERIC MARKING DIAGRAM\*



- XXXXX = Specific Device Code
- A = Assembly Location
- WL = Wafer Lot
- YY = Year
- WW = Work Week
- G = Pb-Free Package

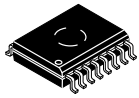
\*This information is generic. Please refer to device data sheet for actual part marking. Pb-Free indicator, "G" or microdot "▪", may or may not be present.

- |                |                     |
|----------------|---------------------|
| STYLE 1:       | STYLE 2:            |
| PIN 1. CATHODE | PIN 1. COMMON DRAIN |
| 2. CATHODE     | 2. COMMON DRAIN     |
| 3. CATHODE     | 3. COMMON DRAIN     |
| 4. CATHODE     | 4. COMMON DRAIN     |
| 5. CATHODE     | 5. COMMON DRAIN     |
| 6. CATHODE     | 6. COMMON DRAIN     |
| 7. CATHODE     | 7. COMMON DRAIN     |
| 8. CATHODE     | 8. COMMON DRAIN     |
| 9. ANODE       | 9. GATE             |
| 10. ANODE      | 10. SOURCE          |
| 11. ANODE      | 11. GATE            |
| 12. ANODE      | 12. SOURCE          |
| 13. ANODE      | 13. GATE            |
| 14. ANODE      | 14. SOURCE          |
| 15. ANODE      | 15. GATE            |
| 16. ANODE      | 16. SOURCE          |

|                         |                    |  |
|-------------------------|--------------------|--|
| <b>DOCUMENT NUMBER:</b> | <b>98ASB42431B</b> | Electronic versions are uncontrolled except when accessed directly from the Document Repository. Printed versions are uncontrolled except when stamped "CONTROLLED COPY" in red. |
| <b>DESCRIPTION:</b>     | <b>PDIP-16</b>     | <b>PAGE 1 OF 1</b>   |

ON Semiconductor and ON are trademarks of Semiconductor Components Industries, LLC dba ON Semiconductor or its subsidiaries in the United States and/or other countries. ON Semiconductor reserves the right to make changes without further notice to any products herein. ON Semiconductor makes no warranty, representation or guarantee regarding the suitability of its products for any particular purpose, nor does ON Semiconductor assume any liability arising out of the application or use of any product or circuit, and specifically disclaims any and all liability, including without limitation special, consequential or incidental damages. ON Semiconductor does not convey any license under its patent rights nor the rights of others.

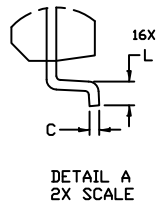
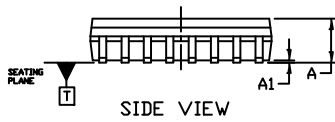
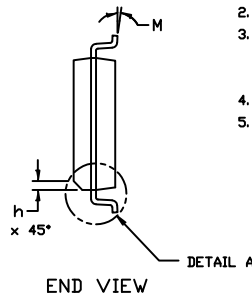
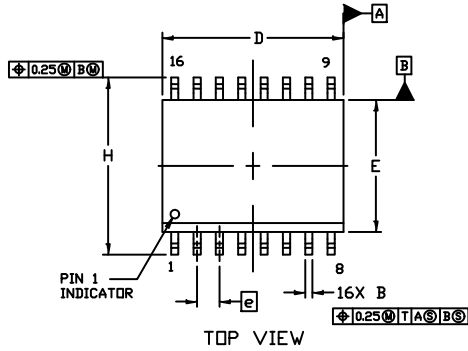
# MECHANICAL CASE OUTLINE PACKAGE DIMENSIONS



1  
SCALE 1:1

SOIC-16 WB  
CASE 751G  
ISSUE E

DATE 08 OCT 2021

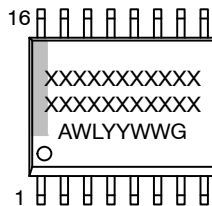


NOTES:

1. DIMENSIONING AND TOLERANCING PER ASME Y14.5M, 1994.
2. CONTROLLING DIMENSION: MILLIMETERS
3. DIMENSION b DOES NOT INCLUDE DAMBAR PROTRUSION. ALLOWABLE PROTRUSION SHALL BE 0.13 TOTAL IN EXCESS OF B DIMENSION AT MAXIMUM MATERIAL CONDITION.
4. DIMENSIONS D AND E DO NOT INCLUDE MOLD PROTRUSIONS.
5. MAXIMUM MOLD PROTRUSION OR FLASH TO BE 0.15 PER SIDE.

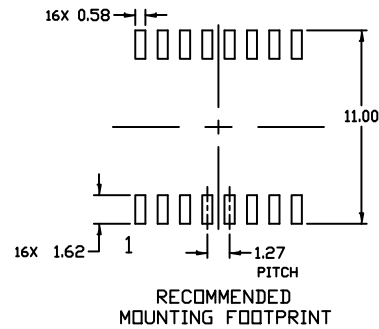
| DIM | MILLIMETERS |       |
|-----|-------------|-------|
|     | MIN.        | MAX.  |
| A   | 2.35        | 2.65  |
| A1  | 0.10        | 0.25  |
| B   | 0.35        | 0.49  |
| C   | 0.23        | 0.32  |
| D   | 10.15       | 10.45 |
| E   | 7.40        | 7.60  |
| e   | 1.27 BSC    |       |
| H   | 10.05       | 10.55 |
| h   | 0.53 REF    |       |
| L   | 0.50        | 0.90  |
| M   | 0°          | 7°    |

GENERIC MARKING DIAGRAM\*



- XXXXX = Specific Device Code
- A = Assembly Location
- WL = Wafer Lot
- YY = Year
- WW = Work Week
- G = Pb-Free Package

\*This information is generic. Please refer to device data sheet for actual part marking. Pb-Free indicator, "G" or microdot "▪", may or may not be present. Some products may not follow the Generic Marking.



|                  |             |  |
|------------------|-------------|--|
| DOCUMENT NUMBER: | 98ASB42567B | Electronic versions are uncontrolled except when accessed directly from the Document Repository. Printed versions are uncontrolled except when stamped "CONTROLLED COPY" in red. |
| DESCRIPTION:     | SOIC-16 WB  | PAGE 1 OF 1  |

onsemi and onsemi are trademarks of Semiconductor Components Industries, LLC dba onsemi or its subsidiaries in the United States and/or other countries. onsemi reserves the right to make changes without further notice to any products herein. onsemi makes no warranty, representation or guarantee regarding the suitability of its products for any particular purpose, nor does onsemi assume any liability arising out of the application or use of any product or circuit, and specifically disclaims any and all liability, including without limitation special, consequential or incidental damages. onsemi does not convey any license under its patent rights nor the rights of others.

**onsemi**, **Onsemi**, and other names, marks, and brands are registered and/or common law trademarks of Semiconductor Components Industries, LLC dba "**onsemi**" or its affiliates and/or subsidiaries in the United States and/or other countries. **onsemi** owns the rights to a number of patents, trademarks, copyrights, trade secrets, and other intellectual property. A listing of **onsemi**'s product/patent coverage may be accessed at [www.onsemi.com/site/pdf/Patent-Marking.pdf](http://www.onsemi.com/site/pdf/Patent-Marking.pdf). **onsemi** reserves the right to make changes at any time to any products or information herein, without notice. The information herein is provided "as-is" and **onsemi** makes no warranty, representation or guarantee regarding the accuracy of the information, product features, availability, functionality, or suitability of its products for any particular purpose, nor does **onsemi** assume any liability arising out of the application or use of any product or circuit, and specifically disclaims any and all liability, including without limitation special, consequential or incidental damages. Buyer is responsible for its products and applications using **onsemi** products, including compliance with all laws, regulations and safety requirements or standards, regardless of any support or applications information provided by **onsemi**. "Typical" parameters which may be provided in **onsemi** data sheets and/or specifications can and do vary in different applications and actual performance may vary over time. All operating parameters, including "Typicals" must be validated for each customer application by customer's technical experts. **onsemi** does not convey any license under any of its intellectual property rights nor the rights of others. **onsemi** products are not designed, intended, or authorized for use as a critical component in life support systems or any FDA Class 3 medical devices or medical devices with a same or similar classification in a foreign jurisdiction or any devices intended for implantation in the human body. Should Buyer purchase or use **onsemi** products for any such unintended or unauthorized application, Buyer shall indemnify and hold **onsemi** and its officers, employees, subsidiaries, affiliates, and distributors harmless against all claims, costs, damages, and expenses, and reasonable attorney fees arising out of, directly or indirectly, any claim of personal injury or death associated with such unintended or unauthorized use, even if such claim alleges that **onsemi** was negligent regarding the design or manufacture of the part. **onsemi** is an Equal Opportunity/Affirmative Action Employer. This literature is subject to all applicable copyright laws and is not for resale in any manner.

## ADDITIONAL INFORMATION

### TECHNICAL PUBLICATIONS:

Technical Library: [www.onsemi.com/design/resources/technical-documentation](http://www.onsemi.com/design/resources/technical-documentation)  
onsemi Website: [www.onsemi.com](http://www.onsemi.com)

### ONLINE SUPPORT: [www.onsemi.com/support](http://www.onsemi.com/support)

For additional information, please contact your local Sales Representative at [www.onsemi.com/support/sales](http://www.onsemi.com/support/sales)

## Looking for pricing, stock, or lifecycle information?

Click below to explore more details on WIN SOURCE:

 [View MC34025DWR2G on WIN SOURCE](#)

 [ON Semiconductor](#) Information

## Optimize Your Supply Chain with WIN SOURCE Solutions

-  Global Sourcing Solution
-  Obsolete Management
-  Cost Control Management
-  Shortage Management
-  Alternative Solution
-  Excess Inventory Management