



**THE DATASHEET OF
MC33232DG**



MC33232

Power Factor Controller

The MC33232 is the monolithic Integrated Circuit using the SMARTMOS[®] process as the new technology. And is active power factor controller specially design for use as off-line power converter application. This integrated circuit features an internal startup timer for stand-alone application, a one quadrant multiplier for near unity power factor, zero current detector to ensure critical condition operation, transconductance error amplifier, quickstart circuit for enhanced startup, trimmed internal bandgap reference, current sensing comparator, a totem pole output ideally suited for drive a power MOSFET, and a one shot-rigger circuit to eliminate a problem at the light loading.

Also included are protective features consisting of an overvoltage comparator to eliminate runaway output voltage due to removal, and a protect circuit to eliminate thermal runaway. This device is available in dual-in-line and surface mount plastic package.

Features

- One Shot-trigger Circuit to Eliminate a Problem at the Light Loading
- Overvoltage Comparator Eliminates Runaway Output Voltage
- Quickstart Circuit for Enhanced Startup
- Internal Startup Timer
- One Quadrant Multiplier
- Zero Current Detector
- Trimmed 2% Internal Bandgap Reference
- Totem Pole Output with High State Clamp
- Undervoltage Lockout with 6.0 V of Hysteresis
- Low Startup and Operating Current
- These are Pb-Free Devices



ON Semiconductor[®]

<http://onsemi.com>

SILICON MONOLITHIC INTEGRATED CIRCUIT

MARKING DIAGRAMS

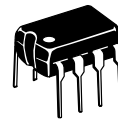

**PDIP-8
P SUFFIX
CASE 626**

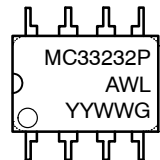

**SOIC-8
D SUFFIX
CASE 751**

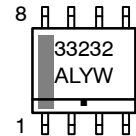

A = Assembly Location
WL or L = Wafer Lot
Y = Year
WW or W = Work Week
G or ■ = Pb-Free Package

PIN ASSIGNMENT

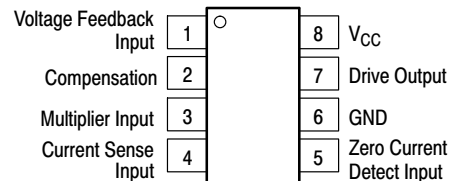

ORDERING INFORMATION

See detailed ordering and shipping information in the package dimensions section on page 2 of this data sheet.

MC33232

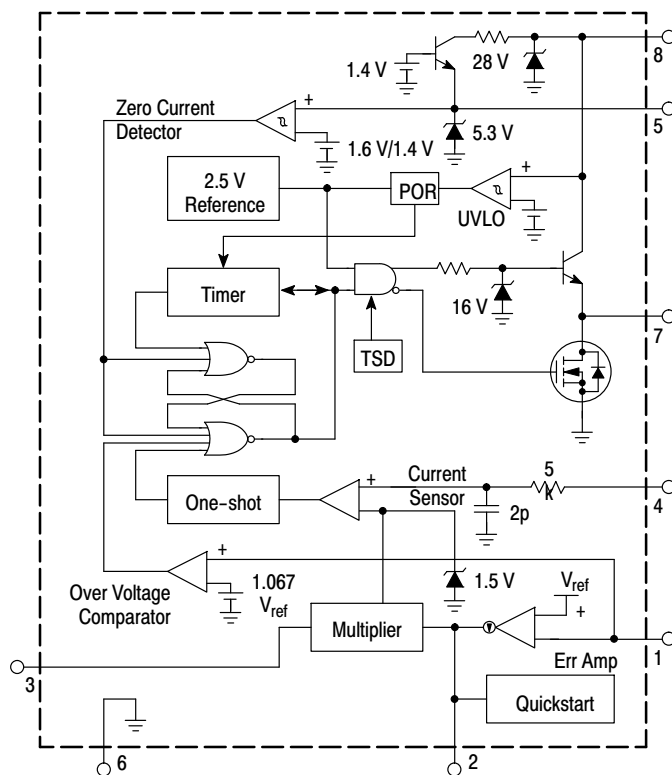

Figure 1. Simplified Block Diagram

ORDERING INFORMATION

Device	Operating Junction Temperature Range	Package	Shipping [†]
MC33232PG	-40°C to +150°C	PDIP-8 (Pb-Free)	50 Units / Rail
MC33232DG		SOIC-8 (Pb-Free)	98 Units / Rail
MC33232DR2G		SOIC-8 (Pb-Free)	2500 Tape & Reel

[†]For information on tape and reel specifications, including part orientation and tape sizes, please refer to our Tape and Reel Packaging Specifications Brochure, BRD8011/D.

MC33232

MAXIMUM RATINGS

Parameter	Symbol	Value	Unit
Total Power Supply and Zener Current	$(I_{CC} + I_Z)$	30	mA
Output Current, Source or Sink (Note 1) Peak Current (Under 0.5 μ sec) DC (Continuously Current)	I_O	750 300	mA
Current Sense, Multiplier and Voltage Feedback Input	V_{in}	-0.3 to 10	V
Zero Current Detect Input High State Forward Current Low State Reverse Current	I_{in}	50 -10	mA
Power Dissipation and Thermal Characteristic D Suffix, Plastic Package, Case 751 Maximum Power Dissipation @ $T_A = 70^\circ\text{C}$ Thermal Resistance, Junction-to-Air P Suffix, Plastic Package, Case 626 Maximum Power Dissipation @ $T_A = 70^\circ\text{C}$ Thermal Resistance, Junction-to-Air	P_D $R_{\theta JA}$ P_D $R_{\theta JA}$	450 178 800 100	mW $^\circ\text{C/W}$ mW $^\circ\text{C/W}$
Operating Junction Temperature	T_J	+150	$^\circ\text{C}$
Storage Temperature	T_{stg}	-55 to +150	$^\circ\text{C}$

Stresses exceeding Maximum Ratings may damage the device. Maximum Ratings are stress ratings only. Functional operation above the Recommended Operating Conditions is not implied. Extended exposure to stresses above the Recommended Operating Conditions may affect device reliability.

- Maximum package power dissipation limits must be observed.

RECOMMENDED OPERATING CONDITION ($V_{CC} = 12\text{ V}$ and $T_A = 25^\circ\text{C}$ unless otherwise noted)

Characteristic	Symbol	Min	Typ	Max	Unit
Operating Frequency ($R_{ZCD} = 4.7\text{ k}\Omega$, $C_{err} = 0.68\text{ }\mu\text{F}$) Normal Loading Under Loading	F		0.4 1.0		MHz
External Resistance for Zero Current Detect Control	R_{ZCD}	-	4.7	-	k Ω
Operating Ambient Temperature	T_A	-20	-	+85	$^\circ\text{C}$

ELECTRICAL CHARACTERISTICS ($V_{CC} = 12\text{ V}$, for typical values $T_A = -20^\circ\text{C} \sim +85^\circ\text{C}$, unless otherwise noted)

Characteristic	Symbol	Min	Typ	Max	Unit
----------------	--------	-----	-----	-----	------

ERROR AMPLIFIER

Voltage Feedback Input Threshold $T_A = 25^\circ\text{C}$ $T_A = -20^\circ\text{C} \sim +85^\circ\text{C}$ ($V_{CC} = 12\text{ V} \sim 25\text{ V}$)	V_{FB}	2.465 2.44	2.5 -	2.535 2.54	V
Line Regulation ($V_{CC} = 12\text{ V} \sim 25\text{ V}$, $T_A = 25^\circ\text{C}$)	Reg_{line}	-	1.0	10	mV
Input Bias Current ($V_{FB} = 0\text{ V}$)	I_{IB}	-	-0.1	-0.5	μA
Transconductance ($T_A = 25^\circ\text{C}$)	gm	80	100	130	μmho
Output Current ($V_{CC} = 12\text{ V} \sim 28\text{ V}$, $T_A = 25^\circ\text{C}$) Source ($V_{FB} = 2.3\text{ V}$) Sink ($V_{FB} = 2.7\text{ V}$)	I_{source} I_{sink}	- -	10 10	- -	μA
Output Voltage Swing High State ($V_{FB} = 2.3\text{ V}$) Low State ($V_{FB} = 2.7\text{ V}$)	$V_{OH(ea)}$ $V_{OL(ea)}$	5.8 -	6.2 1.7	- 2.4	V

OVERVOLTAGE COMPARATOR

Voltage Feedback Input Threshold	V_{TH}	1.04 V_{FB}	1.067 V_{FB}	1.095 V_{FB}	V
----------------------------------	----------	---------------	----------------	----------------	---

OVERTEMPERATURE PROTECT CIRCUIT (This item is just reference value without any specifying)

Detect Temperature	TSD	120	-	-	$^\circ\text{C}$
--------------------	-----	-----	---	---	------------------

MC33232

ELECTRICAL CHARACTERISTICS ($V_{CC} = 12\text{ V}$, for typical values $T_A = -20^\circ\text{C} \sim +85^\circ\text{C}$, unless otherwise noted)

Characteristic	Symbol	Min	Typ	Max	Unit
MULTIPLIER					
Input Threshold (Pin 2)	V_{thm}	1.05 V_{OL} (ea)	1.2 V_{OL} (ea)	–	V
Dynamic Input Voltage Range					V
Multiplier Input (Pin 3)	$V_{pin\ 3}$	0 to 2.5	0 to 3.5	–	
Compensation (Pin 2)	$V_{pin\ 2}$	V_{thm} to $V_{thm} + 1.0$	V_{thm} to $V_{thm} + 1.5$	–	
Input Bias Current, Pin 3 ($V_{FB} = 0\text{ V}$)	$I_{B(mult)}$	–	–0.1	–0.5	μA
Multiplier Gain ($V_{pin\ 3} = 0.5\text{ V}$, $V_{pin\ 2} = V_{FB} + 1.0\text{ V}$)	K	0.43	0.65	0.87	1/V
ZERO CURRENT DETECTOR					
Input Threshold Voltage (V_{in} Increasing)	$V_{th(ZCD)}$	1.33	1.6	1.87	V
Hysteresis (V_{in} Decreasing)	$V_{H(ZCD)}$	100	200	300	mV
Input Clamp Voltage High State ($I_{DET} = +3.0\text{ mA}$)	V_{IH}	5.0	5.3	–	V
Low State ($I_{DET} = -3.0\text{ mA}$)	V_{IL}	0.3	0.7	1.0	
Propagation Delay Time Zero Current Detect to Drive Out $R_{ZCD} = 4.7\text{ k}\Omega$	TZO	–	100	200	nsec
ONE SHOT TRIGGER					
Output Minimum Off Time	T_{OS}	500	–	850	nsec
CURRENT SENSE COMPARATOR					
Input Bias Current ($V_{pin\ 4} = 0\text{ V}$)	$I_{B(cs)}$	–	–0.15	–1.0	μA
Input Offset Voltage ($V_{pin\ 2} = 1.1\text{ V}$, $V_{pin\ 3} = 0\text{ V}$)	$V_{io(cs)}$	–	9.0	25	mV
Maximum Current Sense Input Threshold	V_{thmax}	1.3	1.5	1.8	V
Delay to Output	$t_{PHL(in/out)}$	–	100	200	nsec
DRIVE OUTPUT					
Output Voltage ($V_{CC} = 12\text{ V}$)					V
Low State ($I_{sink} = 20\text{ mA}$)	V_{OL}	–	0.3	0.8	
($I_{sink} = 200\text{ mA}$)		–	2.4	3.3	
High State ($I_{source} = 20\text{ mA}$)	V_{OH}	9.8	10.3	–	V
($I_{source} = 200\text{ mA}$)		7.8	8.4	–	
Output Voltage ($V_{CC} = 25\text{ V}$, $I_{source} = 20\text{ mA}$, $C_L = 15\text{ pF}$)	V_O	14	16	18	V
Output Voltage Rise Time ($C_L = 1.0\text{ nF}$)	t_r	–	50	120	nsec
Output Voltage Fall Time ($C_L = 1.0\text{ nF}$)	t_f	–	50	120	nsec
Output Voltage with UVLO Active ($V_{CC} = 7.0\text{ V}$, $I_{sink} = 1.0\text{ mA}$)	$V_{O(UVLO)}$	–	0.1	0.5	V
RESTART TIMER					
Restart Time Delay	tDLY	200	900	–	μsec
Restart Time at Startup	POR	0	25	–	μsec
UNDER VOLTAGE LOCKOUT (Metal Option Version)					
Startup Threshold (V_{CC} Increasing)	$V_{th(on)}$	14.4	16	17.6	V
Minimum Operating Voltage After Turn-off (V_{CC} Decreasing)	V_{shut}	9.0	10	11	V
Hysteresis	V_H	3.5	6.0	8.6	V
TOTAL DEVICE					
Power Supply Current Startup ($V_{CC} = 7.0\text{ V}$)	I_{CC}	–	0.05	0.1	mA
Operating		–	6.5	12	
Dynamic Operating (50 KHz, $C_L = 1.0\text{ nF}$)		–	9.0	20	
Power Supply Zener Voltage ($I_{CC} = 25\text{ mA}$)	VZ	26	28	–	V

MEASUREMENT CONDITION Note: Test conditions follow the test circuit diagram unless otherwise noted (See last page)

Item	Condition		Measurement Method
V _{FB}		Pin 1 = Pin 2	Measure Pin 1 voltage when connect Pin 1 and Pin 2
V _{FB2}	SW1 = B		
Regline			Regline = V _{FB2} - V _{FB}
I _{B(err)}	Pin 1 = 0 V		Measure Pin 1 current
gm	Pin 2 = 2.0 V Pin 2 current (I _{pin2}) @ Pin 1 = 2.55 Pin 2 current (I _{pin2}) @ Pin 1 = 2.45		$gm = \frac{(I_{pin2} - I'_{pin2})}{(2.55 - 2.45)}$
I _{source}	Pin 1 = 2.3 V	SW1 = A&B Pin 2 = 2.0 V	Measure Pin 2 output current
I _{sink}	Pin 1 = 2.7 V		
V _{OH(ea)}	Pin 1 = 2.3 V		Measure Pin 2 voltage
V _{OL(ea)}	Pin 1 = 2.7 V		
V _{th}	V _{in} = Ref.1 Pin 4 = GND	Pin 2 = 4.0 V Pin 3 = 2.0 V	Measure Pin 1 voltage when Pin 7 switch to low by increasing Pin 1 voltage from 0 V
V _{th(mult)}	V _{in} = Ref.1 Pin 1 = 0 V	Pin 4 = 0.015 V Pin 3 = 0.5 V	Measure Pin 2 voltage when Pin 7 switch to low by decreasing Pin 2 voltage from 2.5 V
V _{pin3}	V _{in} = Ref.1 Pin 2 = V _{th(mult)} Measure Pin 4 voltage when Pin 7 switch to low with each Pin 3 condition		$\alpha = \frac{C}{A} \times \frac{0.77}{1.67} + A$ $25\% \cdot \frac{ B - \alpha }{ C - A } \times 100$ Measure the A, B and C with the condition and calculate the linearity of the multiplier
V _{pin2}	A: @ Pin 3 = 0 V B: @ Pin 3 = 1.25 V C: @ Pin 3 = 2.5 V		
I _{B(mult)}	Pin 1, 3 = 0 V	Pin 2 = 1.1 V	Measure Pin 3 current
K	Pin 1 = 0 V Pin 2 = V _{th(mult)} + 1 V	Pin 3 = 0.5 V V _{in} = Ref.1	Measure V _{thp4} as Pin 4 voltage when Pin 7 switch to low by increasing Pin 4 voltage from 0 V and calculate by the following equation. $K = V_{thp4} / 0.50$
V _{th(ZCD)}	V _{in} = Ref.1	Pin 1 = 0 V Pin 2 = 3.0 V Pin 3 = 0.5 V Pin 4 = GND	Measure Pin 5 voltage when Pin 7 switch to low by increasing V _{in} voltage from 0 V
V _H			Measure V _{th2} as Pin 5 voltage when Pin 7 switch to low by increasing V _{in} voltage from 4 V and calculate V _H by the following equation. $V_H = V_{th(zero)} - V_{th2}$
TZO	SW3 = ON		Measure the propagation delay time from V _{in} to Pin 7
TZO2	SW2 = B		
TOS	V _{in} = Ref.1 Pin 3 = 0.5 V Delay: 500 nSec ~ 700 nSec	Pin 1 = 0 V	Measure the minimum off time for Pin 7

Ref.1: Pin 4 = GND, V_{in} = 4 V return to zero pulse

MEASUREMENT CONDITION

Item	Condition		Measurement Method
$V_{IH(ZCD)}$	Pin 1 = 0 V	Pin 5 = 3 mA	Measure Pin 5 voltage at 3 mA to Pin 5
$V_{IL(ZCD)}$	Pin 2 = 1.1 V	Pin 5 = -3 mA	Measure Pin 5 voltage at -3 mA to Pin 5
$I_{B(CS)}$		Pin 4 = 0 V	Measure Pin 4 current
$V_{IO(CS)}$		Pin 3 = 0 V $V_{in} = \text{Ref.1}$	Measure Pin 4 voltage when Pin 7 switch to low by increasing Pin 4 voltage from -0.3 V
t_{PHL}	Pin 1 = 0 V Pin 2 = $V_{th(mult)} + 0.5 \text{ V}$ Pin 3 = 0.5 V Pin 4 = See right figure $V_{in} = \text{Ref.1}$ $V_{th(cs)}$: Threshold voltage of Pin 4 (at Pin 2 = $V_{th(mult)} + 0.5 \text{ V}$, Pin 3 = 0.5 V)		
$V_{th(max)}$	Pin 1 = 0 V Pin 2 = 4.0 V	Pin 3 = 3.0 V $V_{in} = \text{Ref.1}$	Measure Pin 4 voltage when Pin 7 switch to low by increasing Pin 4 voltage from 0 V
$V_{OL(OUT)}$	Pin 1 = 0 V	Pin 7 = 20 mA	Measure Pin 7 voltage at 20 mA to Pin 7
	SW2 = C	Pin 7 = 200 mA	Measure Pin 7 voltage at 200 mA to Pin 7
$V_{OH(OUT)}$	Pin 1 = 0 V	Pin 7 = -20 mA	Measure Pin 7 voltage at -20 mA to Pin 7
	Pin 4 = GND	Pin 7 = -200 mA	Measure Pin 7 voltage at -200 mA to Pin 7
$V_{O(max)}$	$V_{in} = \text{Ref.1}$	SW1 = C Pin 7 = -20 mA	Measure Pin 7 voltage at -20 mA to Pin 7
t_r t_f	Pin 1, 4 = 0 V SW3 = ON $V_{in} = \text{See right figure}$ f = 50 KHz		
$V_{O(UVLO)}$	Pin 1 = 0 V SW1 = D	Pin 7 = 1.0 mA	Measure Pin 7 voltage at 10 mA to Pin 7
$V_{th(ON)}$	SW1 = E		Measure Pin 8 voltage when Pin 2 change to over 1 V by increasing Pin 8 voltage from 7 V
V_{shut}	Pin 4 = 0 V		Measure Pin 8 voltage when Pin 2 change to under 1 V by increasing Pin 8 voltage from 15 V
V_H	$V_{in} = 0 \text{ V}$		$V_H = V_{th(on)} - V_{shut}$
$I_{CC \text{ Startup}}$	Pin 1 = 0 V	SW1 = D	Measure Pin 8 current
Operating			
Dynamic Operating	Pin 1 = 0 V	Pin 4 = 0 V Pin 2 = 2.5 V SW3 = ON Pin 3 = 0.5 V V_{in} : Low = 0 V, High = 4 V f_{in} = Square Wave @ TBD KHz	Measure Pin 8 current

Ref.1: Pin 4 = GND, $V_{in} = 4 \text{ V}$ return to zero pulse

MC33232

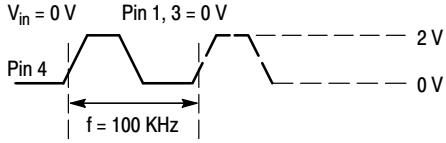
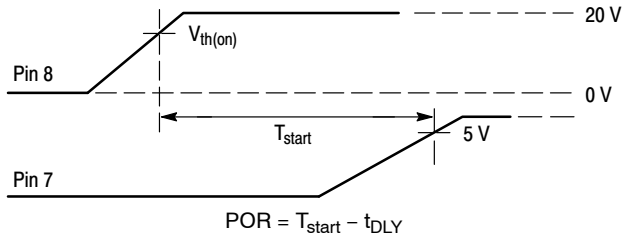
Item	Condition	Measurement Method
V_Z	SW1 = E Pin 8 = 25 mA Pin 5 = 2.0 V Pin 1, 4 = 0 V	Measure Pin 8 voltage
t_{DLY}	$V_{in} = 0 V$ Pin 1, 3 = 0 V 	Measure Pin 7 frequency (FPin 7) $t_{DLY} = 1 / \text{FPin 7}$
POR	SW1 = E Pin 4 = 0 V $V_{in} = 0 V$	 $\text{POR} = T_{\text{start}} - t_{\text{DLY}}$

TEST CIRCUIT

To follow unless otherwise noted

SW1: A
SW2: A
SW3: OFF

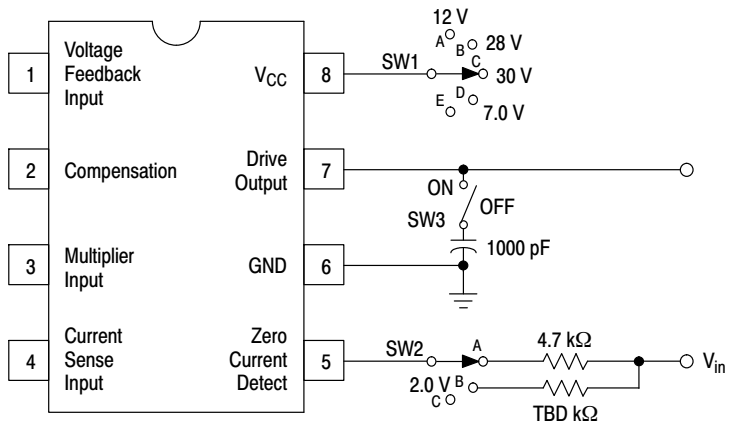

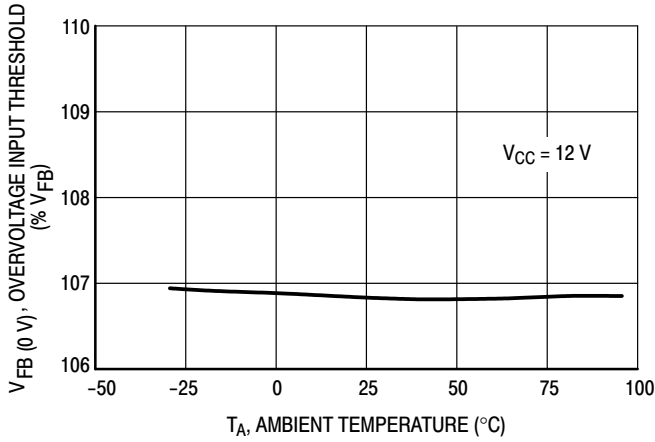

Figure 2. Overtolerance Comparator Input Threshold versus Temperature

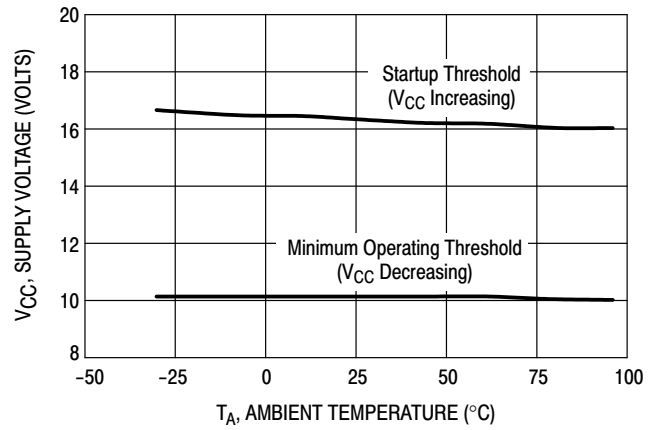

Figure 3. Undervoltage Lockout Thresholds versus Temperature

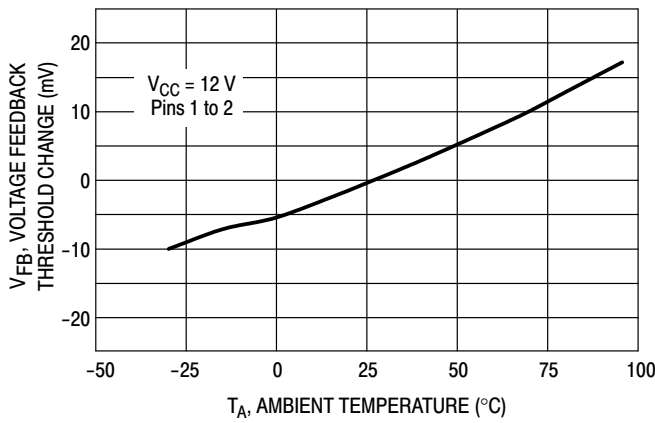

Figure 4. Voltage Feedback Input Threshold Change versus Temperature

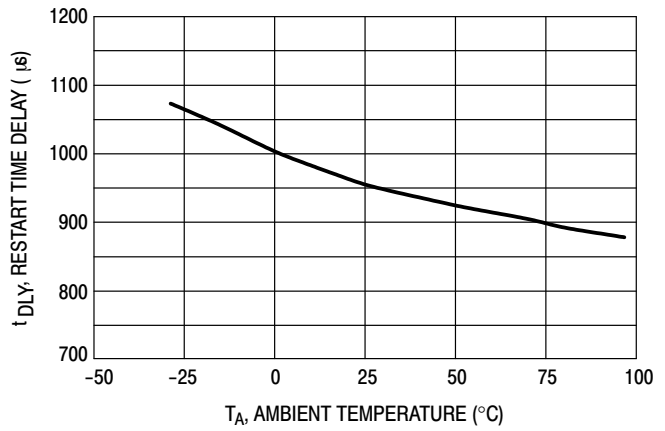

Figure 5. Restart Timer Delay versus Temperature

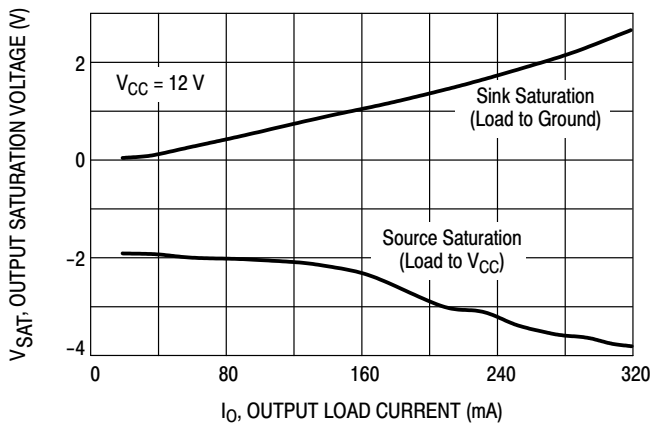

Figure 6. Output Saturation Voltage versus Load Current

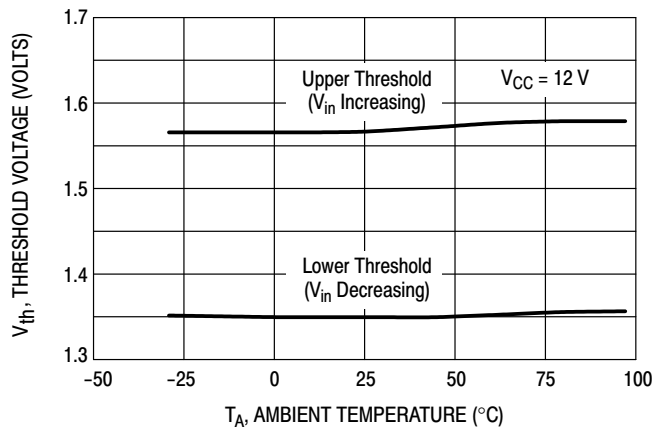

Figure 7. Zero Current Detector Input Threshold versus Temperature

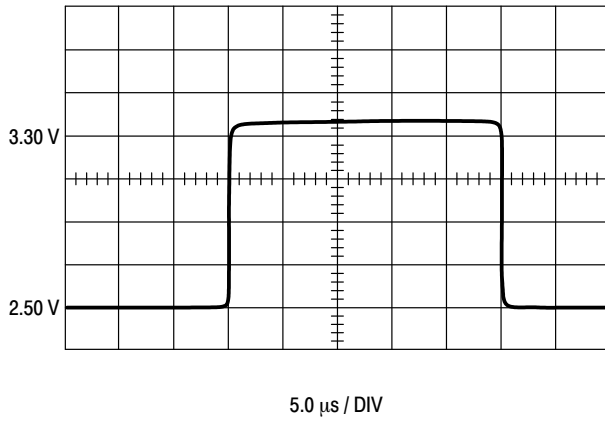

Figure 8. Error Amp Transient Response

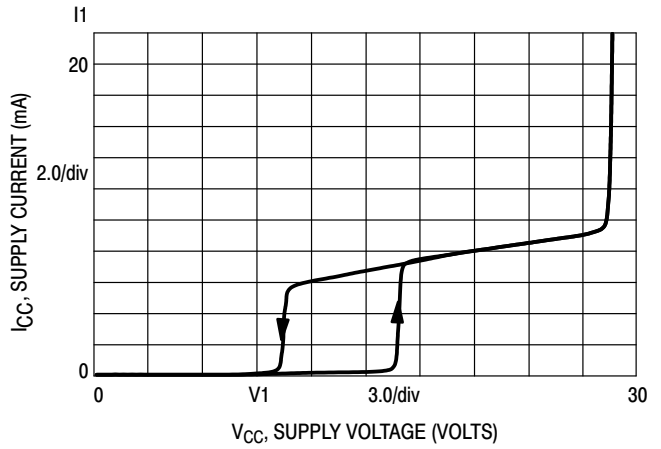

Figure 9. Supply Current versus Supply Voltage

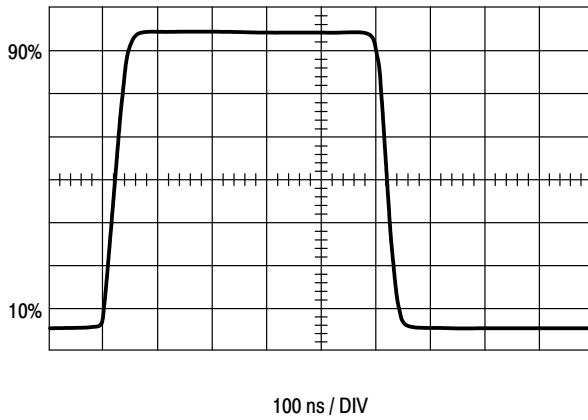

Figure 10. Drive Output Waveform

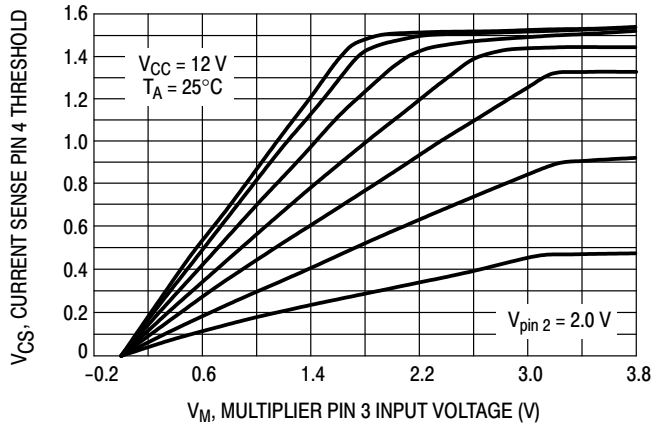

Figure 11. Restart Timer Delay versus Temperature

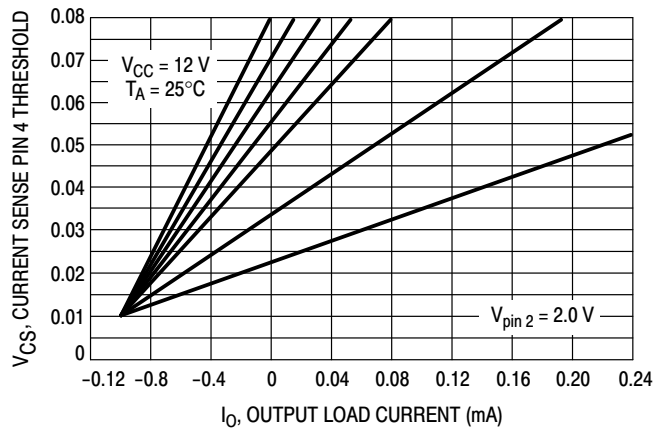

Figure 12. Current Sense Input Threshold versus Multiplier Input (Expanded View)

PIN FUNCTION DESCRIPTION

Name	Pin No.	Equivalent Circuit	Function
V _{FB}	1		<p>Voltage Feedback Input</p> <p>This pin is an input for error amplifier to feedback the voltage from the converter output. Have the overvoltage detect circuit to cut off the drive out when the voltage is over 8% from setting value.</p>
COMP	2		<p>Error Amplifier Output/Compensation</p> <p>This pin is an error amplifier output. Can do phase compensation or gain adjustment by this pin.</p>
Mult	3		<p>Multiplier Input</p> <p>Monitor the AC off line voltage using this input.</p>
CS	4		<p>Current Sense Input</p> <p>Control the output voltage by sensing the overcurrent at each cycle. This pin connects the RC filter and 1.5 V clamp diode.</p>

MC33232

PIN FUNCTION DESCRIPTION

Name	Pin No.	Equivalent Circuit	Function
ZCD	5		<p>Zero Current Detect Input</p> <p>Control the output ON point to detect the zero current point on the coil. This pin has the 0.7 V and 5.3 V clamp diode internal.</p>
GND	6		Ground
Output	7		<p>Drive Out</p> <p>Totem pole output.</p>
V _{CC}	8		Power Supply

MC33232

INTERNAL EQUIVALENT CIRCUIT

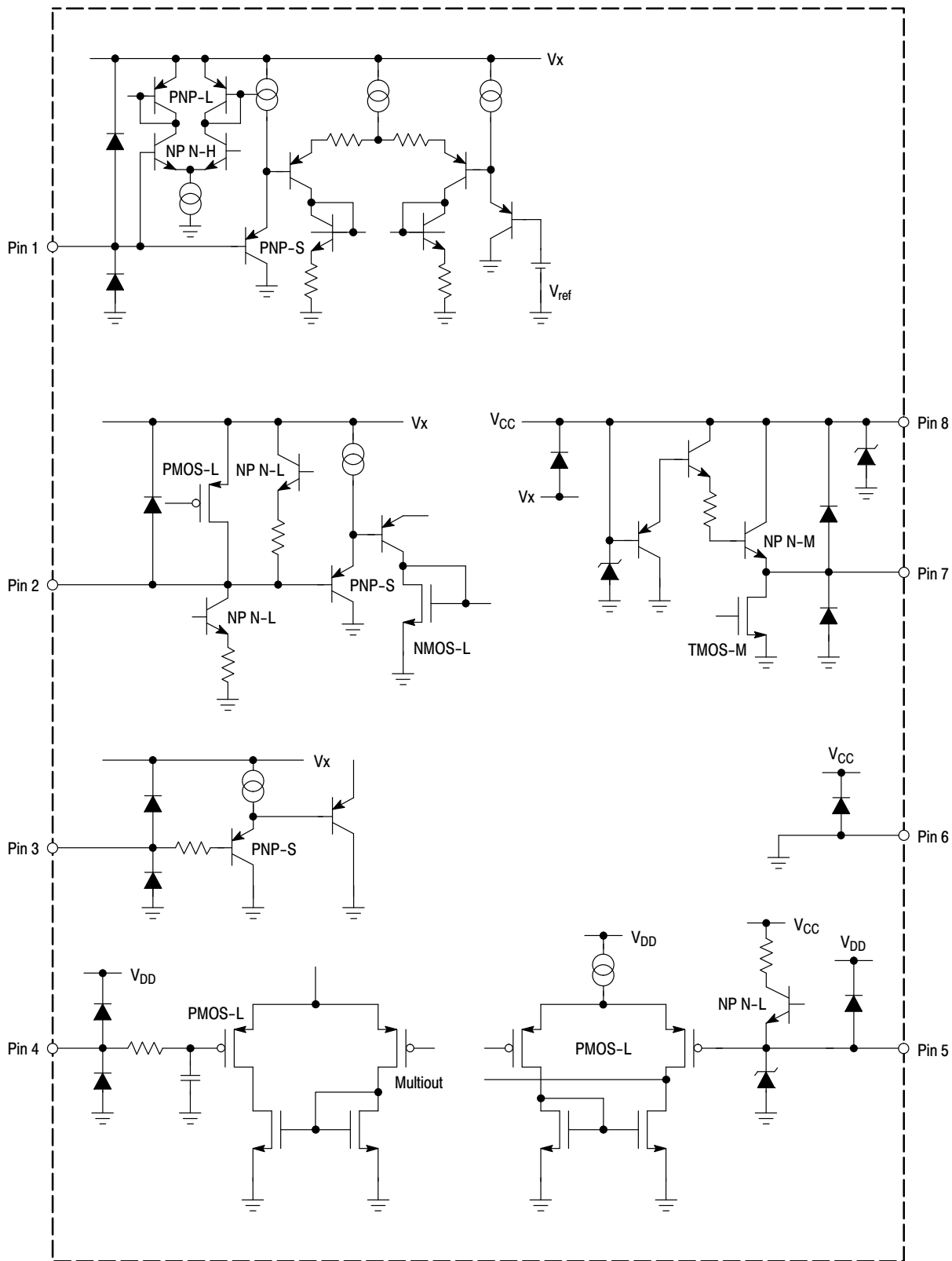

MC33232

SUGGESTED APPLICATION CIRCUIT

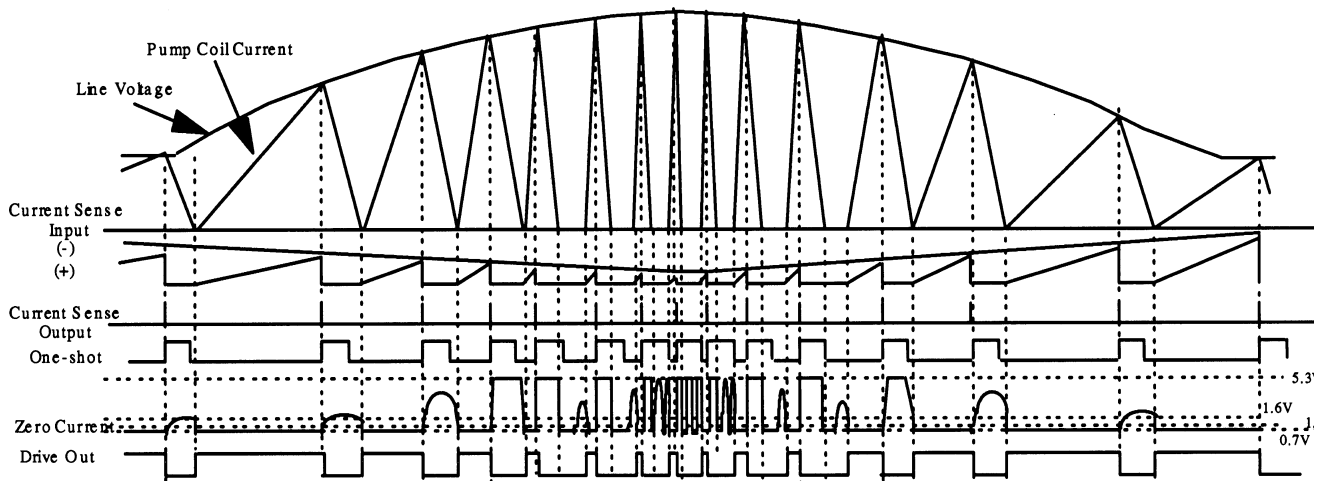
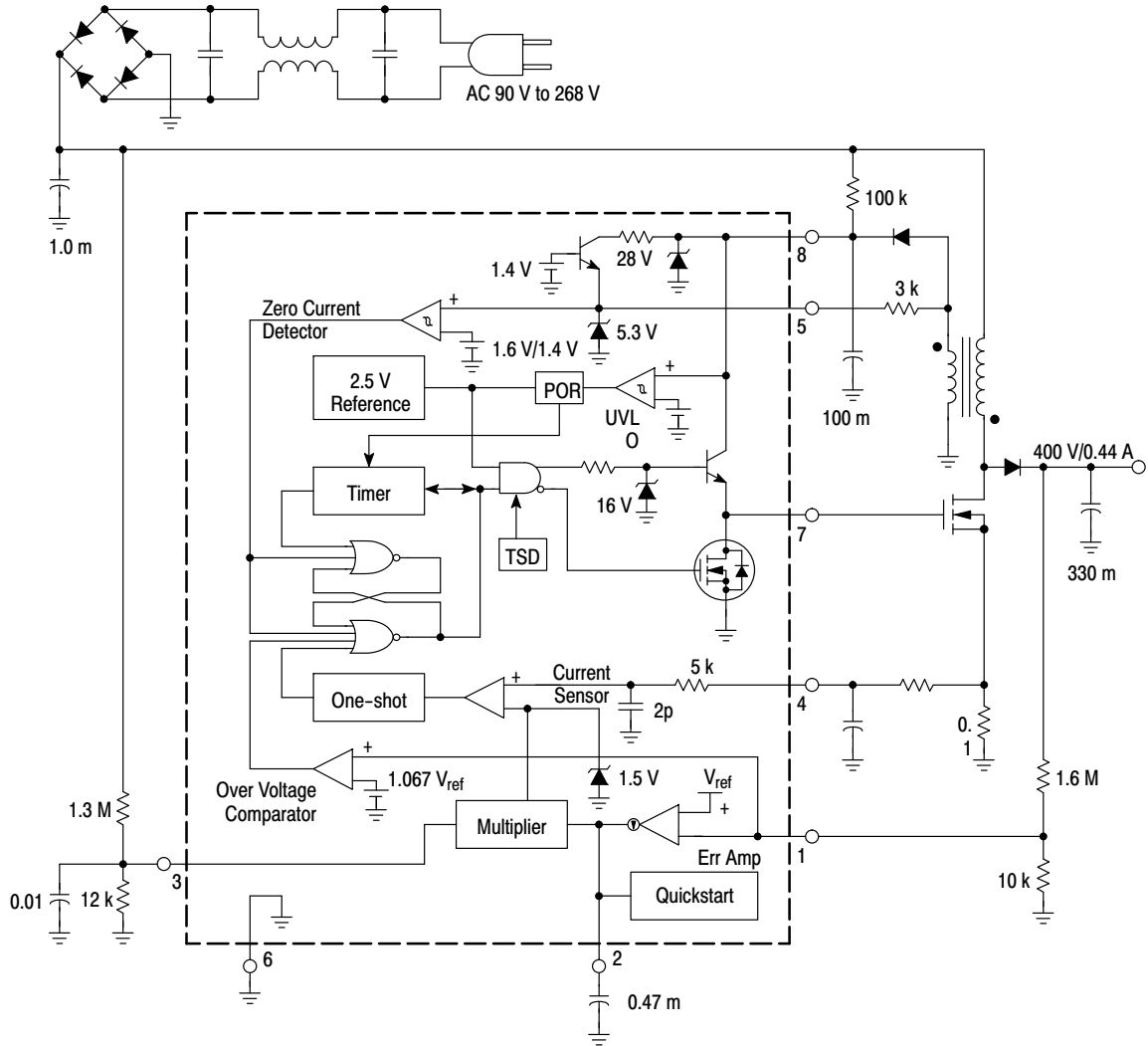

MC33232

PACKAGE DIMENSIONS

PDIP-8
P SUFFIX
CASE 626-05
ISSUE L

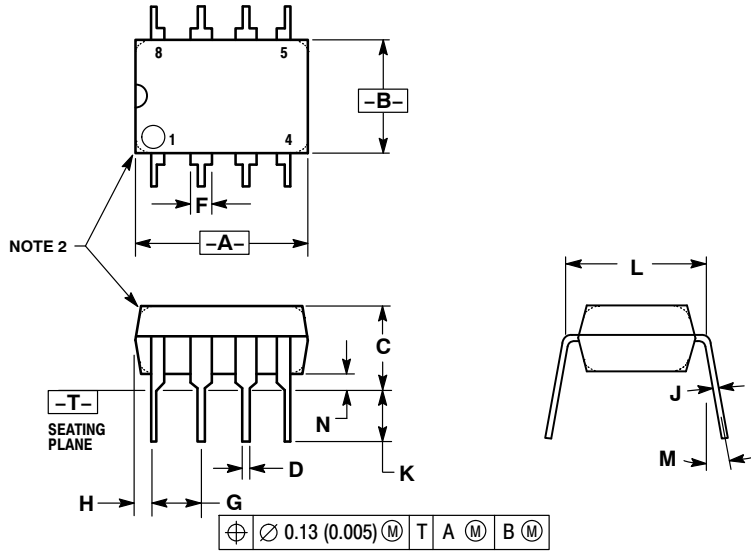

NOTES:

1. DIMENSION L TO CENTER OF LEAD WHEN FORMED PARALLEL.
2. PACKAGE CONTOUR OPTIONAL (ROUND OR SQUARE CORNERS).
3. DIMENSIONING AND TOLERANCING PER ANSI Y14.5M, 1982.

DIM	MILLIMETERS		INCHES	
	MIN	MAX	MIN	MAX
A	9.40	10.16	0.370	0.400
B	6.10	6.60	0.240	0.260
C	3.94	4.45	0.155	0.175
D	0.38	0.51	0.015	0.020
F	1.02	1.78	0.040	0.070
G	2.54 BSC		0.100 BSC	
H	0.76	1.27	0.030	0.050
J	0.20	0.30	0.008	0.012
K	2.92	3.43	0.115	0.135
L	7.62 BSC		0.300 BSC	
M	---	10 [°]	---	10 [°]
N	0.76	1.01	0.030	0.040

MC33232

PACKAGE DIMENSIONS

SOIC-8
D SUFFIX
CASE 751-07
ISSUE AJ

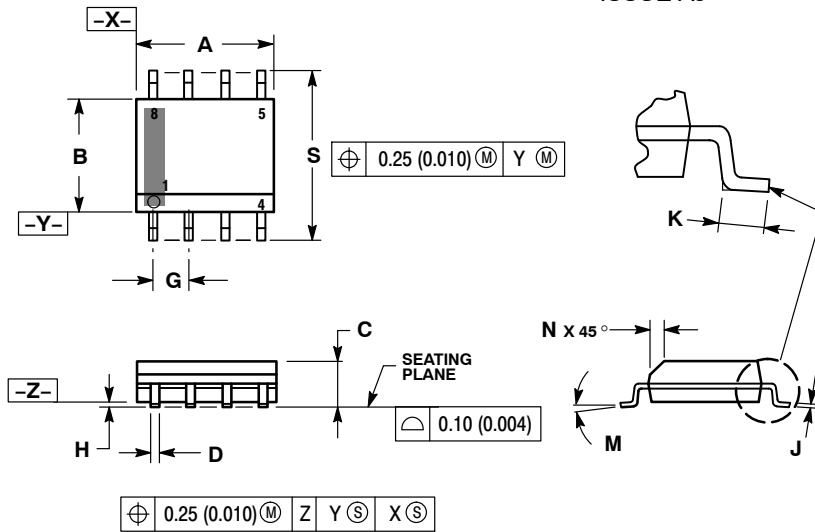

NOTES:

1. DIMENSIONING AND TOLERANCING PER ANSI Y14.5M, 1982.
2. CONTROLLING DIMENSION: MILLIMETER.
3. DIMENSION A AND B DO NOT INCLUDE MOLD PROTRUSION.
4. MAXIMUM MOLD PROTRUSION 0.15 (0.006) PER SIDE.
5. DIMENSION D DOES NOT INCLUDE DAMBAR PROTRUSION. ALLOWABLE DAMBAR PROTRUSION SHALL BE 0.127 (0.005) TOTAL IN EXCESS OF THE D DIMENSION AT MAXIMUM MATERIAL CONDITION.
6. 751-01 THRU 751-06 ARE OBSOLETE. NEW STANDARD IS 751-07.

DIM	MILLIMETERS		INCHES	
	MIN	MAX	MIN	MAX
A	4.80	5.00	0.189	0.197
B	3.80	4.00	0.150	0.157
C	1.35	1.75	0.053	0.069
D	0.33	0.51	0.013	0.020
G	1.27 BSC		0.050 BSC	
H	0.10	0.25	0.004	0.010
J	0.19	0.25	0.007	0.010
K	0.40	1.27	0.016	0.050
M	0°	8°	0°	8°
N	0.25	0.50	0.010	0.020
S	5.80	6.20	0.228	0.244

SOLDERING FOOTPRINT*

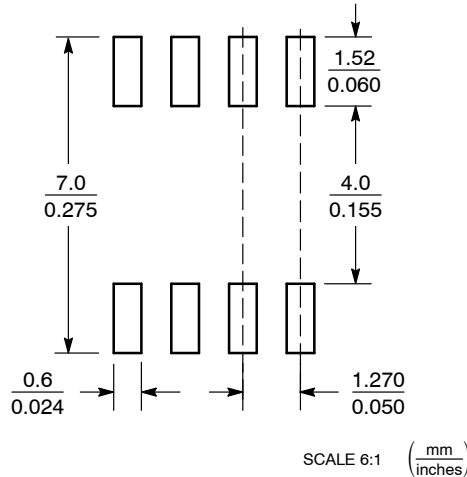

*For additional information on our Pb-Free strategy and soldering details, please download the ON Semiconductor Soldering and Mounting Techniques Reference Manual, SOLDERRM/D.

SMARTMOS is a registered trademark of Motorola, Inc.

ON Semiconductor and are registered trademarks of Semiconductor Components Industries, LLC (SCILLC). SCILLC reserves the right to make changes without further notice to any products herein. SCILLC makes no warranty, representation or guarantee regarding the suitability of its products for any particular purpose, nor does SCILLC assume any liability arising out of the application or use of any product or circuit, and specifically disclaims any and all liability, including without limitation special, consequential or incidental damages. "Typical" parameters which may be provided in SCILLC data sheets and/or specifications can and do vary in different applications and actual performance may vary over time. All operating parameters, including "Typicals" must be validated for each customer application by customer's technical experts. SCILLC does not convey any license under its patent rights nor the rights of others. SCILLC products are not designed, intended, or authorized for use as components in systems intended for surgical implant into the body, or other applications intended to support or sustain life, or for any other application in which the failure of the SCILLC product could create a situation where personal injury or death may occur. Should Buyer purchase or use SCILLC products for any such unintended or unauthorized application, Buyer shall indemnify and hold SCILLC and its officers, employees, subsidiaries, affiliates, and distributors harmless against all claims, costs, damages, and expenses, and reasonable attorney fees arising out of, directly or indirectly, any claim of personal injury or death associated with such unintended or unauthorized use, even if such claim alleges that SCILLC was negligent regarding the design or manufacture of the part. SCILLC is an Equal Opportunity/Affirmative Action Employer. This literature is subject to all applicable copyright laws and is not for resale in any manner.

PUBLICATION ORDERING INFORMATION

LITERATURE FULFILLMENT:
Literature Distribution Center for ON Semiconductor
P.O. Box 5163, Denver, Colorado 80217 USA
Phone: 303-675-2175 or 800-344-3860 Toll Free USA/Canada
Fax: 303-675-2176 or 800-344-3867 Toll Free USA/Canada
Email: orderlit@onsemi.com

N. American Technical Support: 800-282-9855 Toll Free USA/Canada
Europe, Middle East and Africa Technical Support:
Phone: 421 33 790 2910
Japan Customer Focus Center
Phone: 81-3-5773-3850

ON Semiconductor Website: www.onsemi.com

Order Literature: <http://www.onsemi.com/orderlit>

For additional information, please contact your local Sales Representative

Looking for pricing, stock, or lifecycle information?

Click below to explore more details on WIN SOURCE:

 [View MC33232DG](#) on WIN SOURCE

 [ON Semiconductor](#) Information

Optimize Your Supply Chain with WIN SOURCE Solutions

-  Global Sourcing Solution
-  Obsolete Management
-  Cost Control Management
-  Shortage Management
-  Alternative Solution
-  Excess Inventory Management