



**THE DATASHEET OF
MC33023DWR2G**



MC34023, MC33023

High Speed Single-Ended PWM Controller

The MC34023 series are high speed, fixed frequency, single-ended pulse width modulator controllers optimized for high frequency operation. They are specifically designed for Off-Line and DC-to-DC converter applications offering the designer a cost-effective solution with minimal external components. These integrated circuits feature an oscillator, a temperature compensated reference, a wide bandwidth error amplifier, a high speed current sensing comparator, and a high current totem pole output ideally suited for driving a power MOSFET.

Also included are protective features consisting of input and reference undervoltage lockouts each with hysteresis, cycle-by-cycle current limiting, and a latch for single pulse metering.

The flexibility of this series allows it to be easily configured for either current mode or voltage mode control.

Features

- 50 ns Propagation Delay to Output
- High Current Totem Pole Output
- Wide Bandwidth Error Amplifier
- Fully-Latched Logic with Double Pulse Suppression
- Latching PWM for Cycle-By-Cycle Current Limiting
- Soft-Start Control with Latched Overcurrent Reset
- Input Undervoltage Lockout with Hysteresis
- Low Startup Current (500 μ A Typ)
- Internally Trimmed Reference with Undervoltage Lockout
- 90% Maximum Duty Cycle (Externally Adjustable)
- Precision Trimmed Oscillator
- Voltage or Current Mode Operation to 1.0 MHz
- Functionally Similar to the UC3823
- These are Pb-Free Devices

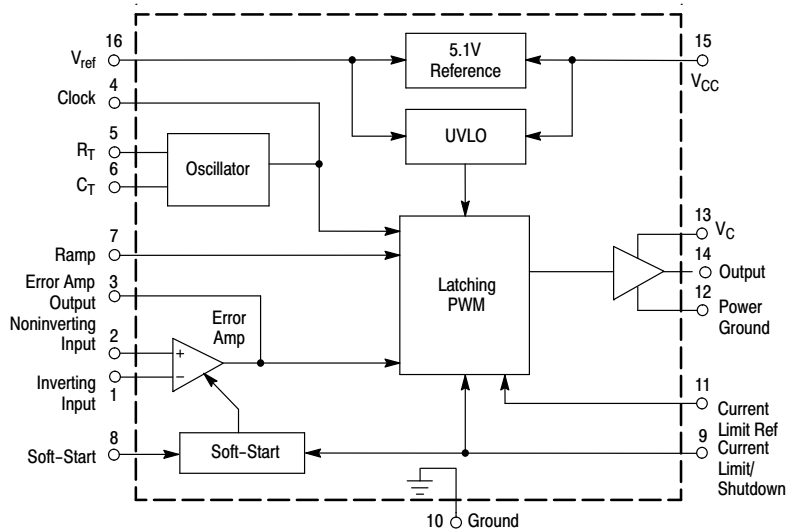
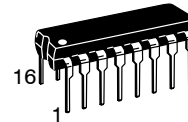

Figure 1. Simplified Application



ON Semiconductor®

<http://onsemi.com>



PDIP-16
P SUFFIX
CASE 648

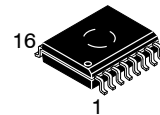

SOIC-16W
DW SUFFIX
CASE 751G

MARKING DIAGRAMS

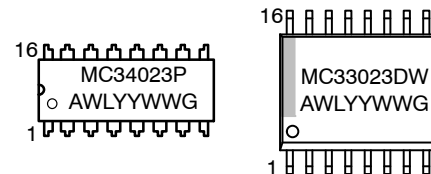

- A = Assembly Location
- WL = Wafer Lot
- YY = Year
- WW = Work Week
- G = Pb-Free Package

PIN CONNECTIONS

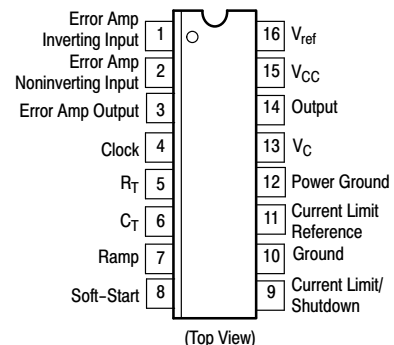

ORDERING INFORMATION

See detailed ordering and shipping information in the package dimensions section on page 2 of this data sheet.

*For additional information on our Pb-Free strategy and soldering details, please download the ON Semiconductor Soldering and Mounting Techniques Reference Manual, SOLDERRM/D.

MC34023, MC33023

ORDERING INFORMATION

Device	Package	Shipping†
MC33023DWG	SOIC-16W (Pb-Free)	47 Units / Rail
MC33023DWR2G	SOIC-16W (Pb-Free)	1000 Units / Reel
MC34023PG	PDIP-16 (Pb-Free)	25 Units / Rail

†For information on tape and reel specifications, including part orientation and tape sizes, please refer to our Tape and Reel Packaging Specifications Brochure, BRD8011/D.

MAXIMUM RATINGS

Rating	Symbol	Value	Unit
Power Supply Voltage	V_{CC}	30	V
Output Driver Supply Voltage	V_C	20	V
Output Current, Source or Sink (Note 1)	I_O		A
DC		0.5	
Pulsed (0.5 μ s)		2.0	
Current Sense, Soft-Start, Ramp, and Error Amp Inputs	V_{in}	-0.3 to +7.0	V
Error Amp Output and Soft-Start Sink Current	I_O	10	mA
Clock and R_T Output Current	I_{CO}	5.0	mA
Power Dissipation and Thermal Characteristics			
SO-16L Package (Case 751G)			
Maximum Power Dissipation @ $T_A = +25^\circ\text{C}$	P_D	862	mW
Thermal Resistance, Junction-to-Air	$R_{\theta JA}$	145	$^\circ\text{C/W}$
DIP Package (Case 648)			
Maximum Power Dissipation @ $T_A = +25^\circ\text{C}$	P_D	1.25	W
Thermal Resistance, Junction-to-Air	$R_{\theta JA}$	100	$^\circ\text{C/W}$
Operating Junction Temperature	T_J	+150	$^\circ\text{C}$
Operating Ambient Temperature (Note 2)	T_A		$^\circ\text{C}$
MC34023		0 to +70	
MC33023		-40 to +105	
Storage Temperature Range	T_{stg}	-55 to +150	$^\circ\text{C}$

Stresses exceeding Maximum Ratings may damage the device. Maximum Ratings are stress ratings only. Functional operation above the Recommended Operating Conditions is not implied. Extended exposure to stresses above the Recommended Operating Conditions may affect device reliability.

MC34023, MC33023

ELECTRICAL CHARACTERISTICS ($V_{CC} = 15\text{ V}$, $R_T = 3.65\text{ k}\Omega$, $C_T = 1.0\text{ nF}$, for typical values $T_A = +25^\circ\text{C}$, for min/max values T_A is the operating ambient temperature range that applies [Note 2], unless otherwise noted.)

Characteristic	Symbol	Min	Typ	Max	Unit
----------------	--------	-----	-----	-----	------

REFERENCE SECTION

Reference Output Voltage ($I_O = 1.0\text{ mA}$, $T_J = +25^\circ\text{C}$)	V_{ref}	5.05	5.1	5.15	V
Line Regulation ($V_{CC} = 10\text{ V to }30\text{ V}$)	Reg_{line}	-	2.0	15	mV
Load Regulation ($I_O = 1.0\text{ mA to }10\text{ mA}$)	Reg_{load}	-	2.0	15	mV
Temperature Stability	T_S	-	0.2	-	mV/ $^\circ\text{C}$
Total Output Variation over Line, Load, and Temperature	V_{ref}	4.95	-	5.25	V
Output Noise Voltage ($f = 10\text{ Hz to }10\text{ kHz}$, $T_J = +25^\circ\text{C}$)	V_n	-	50	-	μV
Long Term Stability ($T_A = +125^\circ\text{C}$ for 1000 Hours)	S	-	5.0	-	mV
Output Short Circuit Current	I_{SC}	-30	-65	-100	mA

OSCILLATOR SECTION

Frequency $T_J = +25^\circ\text{C}$ Line ($V_{CC} = 10\text{ V to }30\text{ V}$) and Temperature ($T_A = T_{low}$ to T_{high})	f_{osc}	380 370	400 400	420 430	kHz
Frequency Change with Voltage ($V_{CC} = 10\text{ V to }30\text{ V}$)	$\Delta f_{osc}/\Delta V$	-	0.2	1.0	%
Frequency Change with Temperature ($T_A = T_{low}$ to T_{high})	$\Delta f_{osc}/\Delta T$	-	2.0	-	%
Sawtooth Peak Voltage	$V_{OSC(P)}$	2.6	2.8	3.0	V
Sawtooth Valley Voltage	$V_{OSC(V)}$	0.7	1.0	1.25	V
Clock Output Voltage High State Low State	V_{OH} V_{OL}	3.9 -	4.5 2.3	- 2.9	V

ERROR AMPLIFIER SECTION

Input Offset Voltage	V_{IO}	-	-	15	mV
Input Bias Current	I_{IB}	-	0.6	3.0	μA
Input Offset Current	I_{IO}	-	0.1	1.0	μA
Open-Loop Voltage Gain ($V_O = 1.0\text{ V to }4.0\text{ V}$)	A_{VOL}	60	95	-	dB
Gain Bandwidth Product ($T_J = +25^\circ\text{C}$)	GBW	4.0	8.3	-	MHz
Common Mode Rejection Ratio ($V_{CM} = 1.5\text{ V to }5.5\text{ V}$)	CMRR	75	95	-	dB
Power Supply Rejection Ratio ($V_{CC} = 10\text{ V to }30\text{ V}$)	PSRR	85	110	-	dB
Output Current, Source ($V_O = 4.0\text{ V}$) Sink ($V_O = 1.0\text{ V}$)	I_{Source} I_{Sink}	0.5 1.0	3.0 3.6	- -	mA
Output Voltage Swing, High State ($I_O = -0.5\text{ mA}$) Low State ($I_O = 1\text{ mA}$)	V_{OH} V_{OL}	4.5 0	4.75 0.4	5.0 1.0	V
Slew Rate	SR	6.0	12	-	V/ μs

PWM COMPARATOR SECTION

Ramp Input Bias Current	I_{IB}	-	-0.5	-5.0	μA
Duty Cycle, Maximum Minimum	$DC_{(max)}$ $DC_{(min)}$	80 -	90 -	- 0	%
Zero Duty Cycle Threshold Voltage Pin 3(4) (Pin 7(9) = 0 V)	V_{th}	1.1	1.25	1.4	V
Propagation Delay (Ramp Input to Output, $T_J = +25^\circ\text{C}$)	$t_{PLH(in/out)}$	-	60	100	ns

SOFT-START SECTION

Charge Current ($V_{Soft-Start} = 0.5\text{ V}$)	I_{chg}	3.0	9.0	20	μA
Discharge Current ($V_{Soft-Start} = 1.5\text{ V}$)	I_{dischg}	1.0	4.0	-	mA

- Maximum package power dissipation limits must be observed.
- Low duty cycle pulse techniques are used during test to maintain junction temperature as close to ambient as possible.
 $T_{low} = 0^\circ\text{C}$ for MC34023
 $T_{high} = +70^\circ\text{C}$ for MC34023
 $T_{low} = -40^\circ\text{C}$ for MC33023
 $T_{high} = +105^\circ\text{C}$ for MC33023

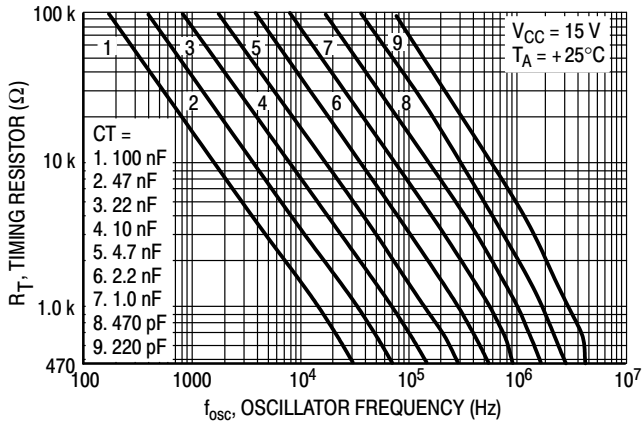

Figure 2. Timing Resistor versus Oscillator Frequency

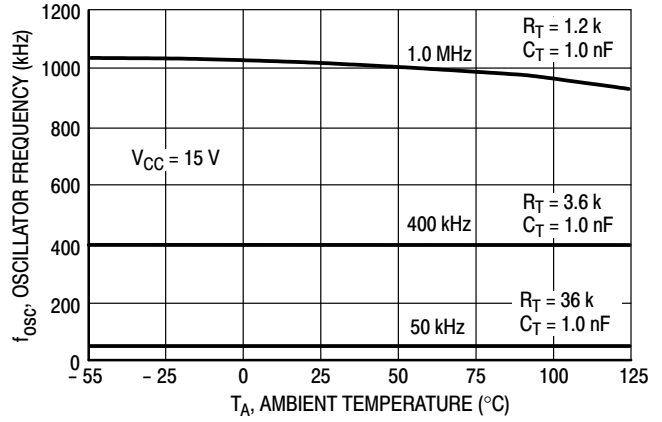

Figure 3. Oscillator Frequency versus Temperature

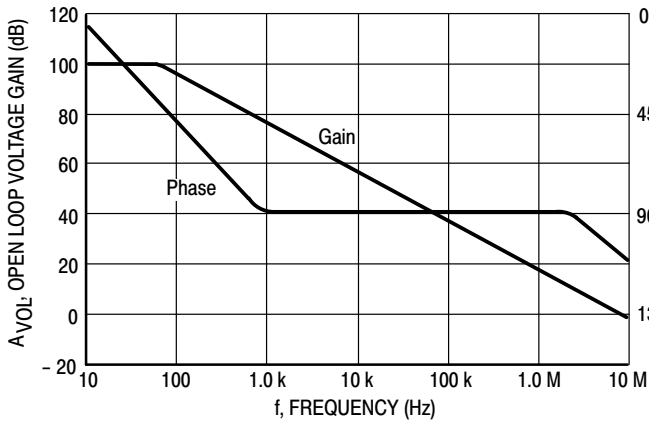

Figure 4. Error Amp Open Loop Gain and Phase versus Frequency

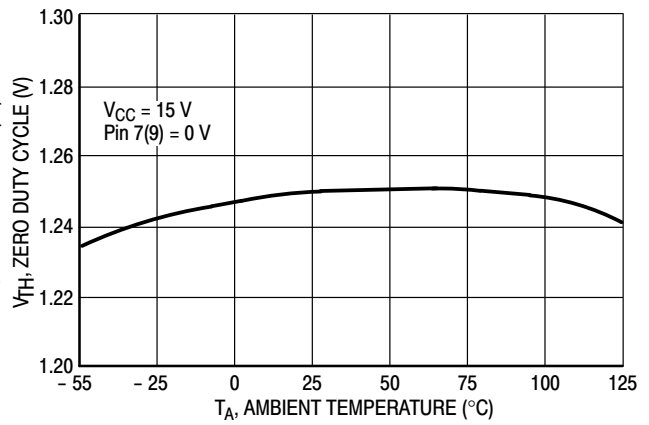

Figure 5. PWM Comparator Zero Duty Cycle Threshold Voltage versus Temperature

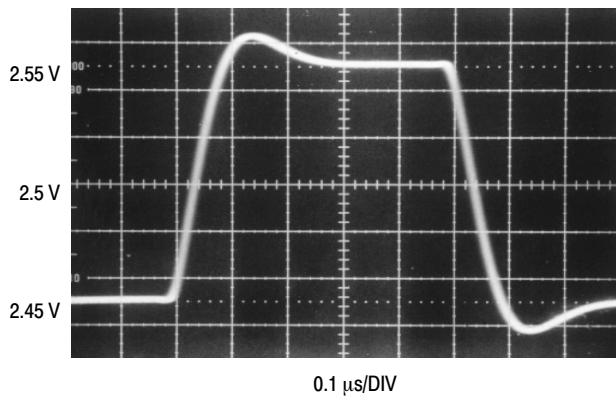

Figure 6. Error Amp Small Signal Transient Response

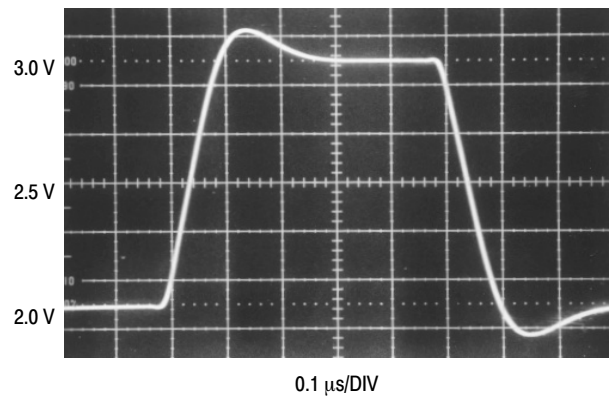

Figure 7. Error Amp Large Signal Transient Response

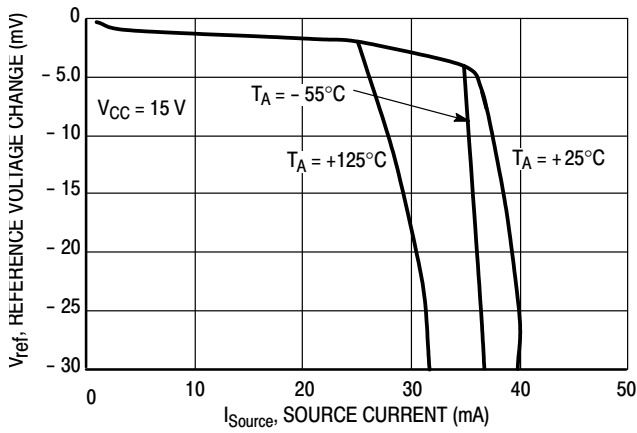

Figure 8. Reference Voltage Change versus Source Current

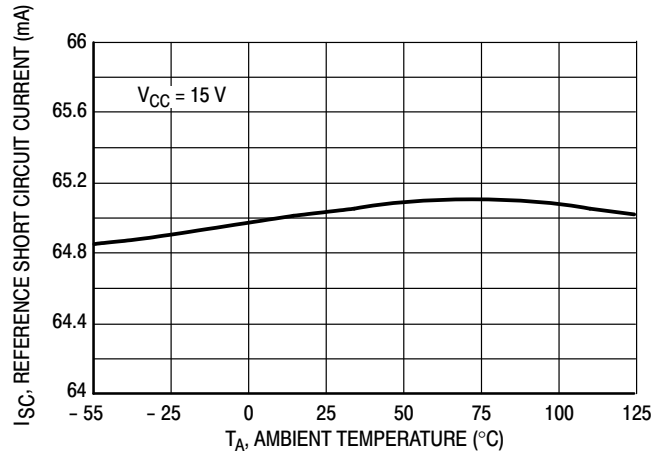
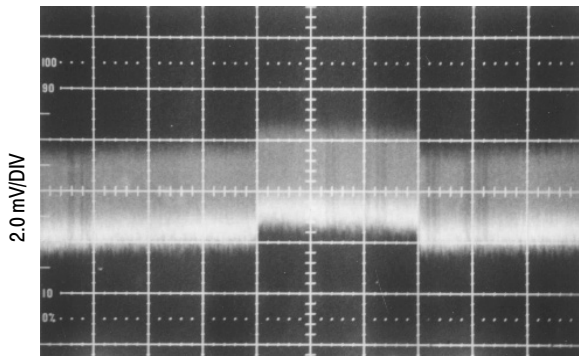
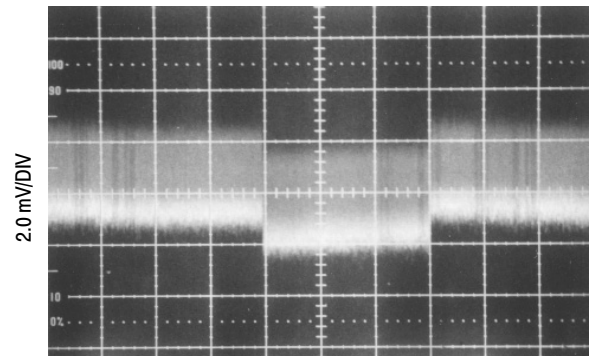

Figure 9. Reference Short Circuit Current versus Temperature



V_{ref} LINE REGULATION 10 V to 24 V
(2.0 ms/DIV)

Figure 10. Reference Line Regulation



V_{ref} LOAD REGULATION 1.0 mA to 10 mA
(2.0 ms/DIV)

Figure 11. Reference Load Regulation

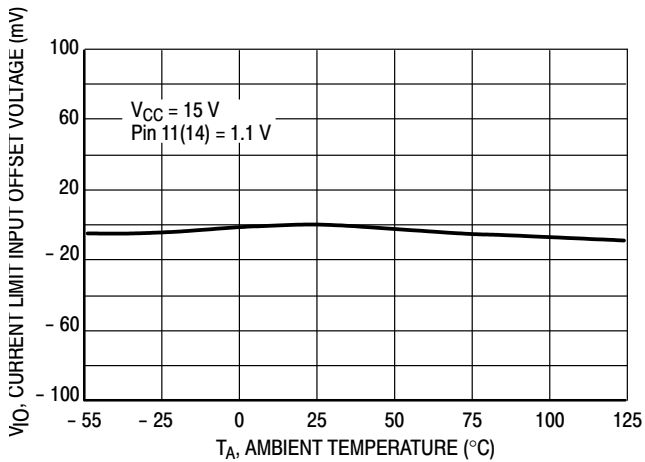

Figure 12. Current Limit Comparator Input Offset Voltage versus Temperature

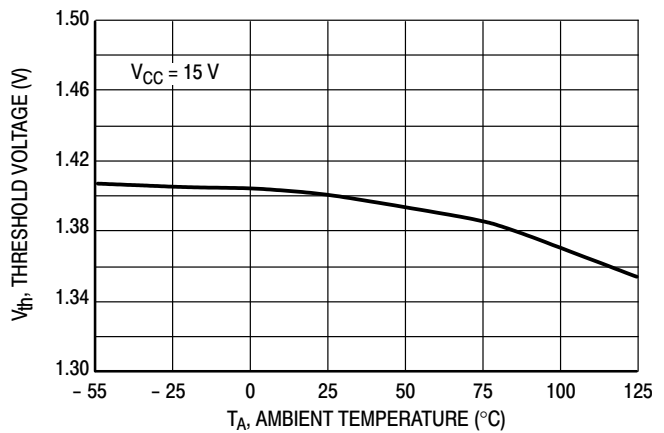

Figure 13. Shutdown Comparator Threshold Voltage versus Temperature

MC34023, MC33023

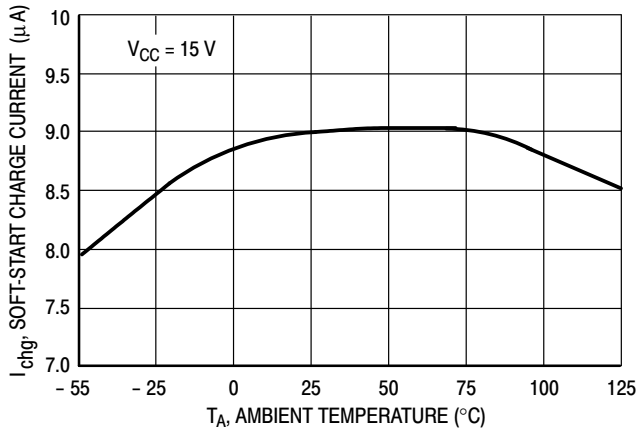

Figure 14. Soft-Start Charge Current versus Temperature

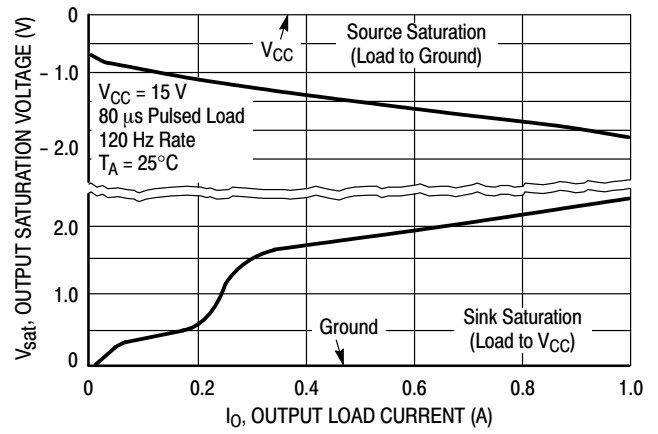
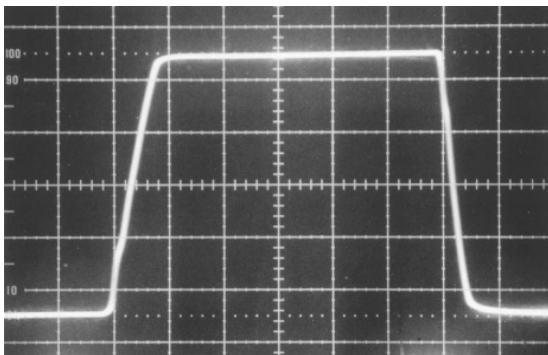
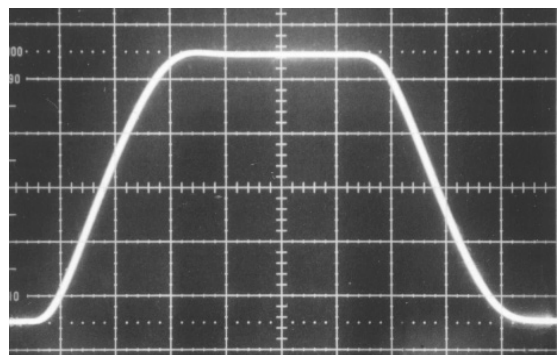

Figure 15. Output Saturation Voltage versus Load Current



OUTPUT RISE & FALL TIME 1.0 nF LOAD
50 ns/DIV

Figure 16. Drive Output Rise and Fall Time



OUTPUT RISE & FALL TIME 10 nF LOAD
50 ns/DIV

Figure 17. Drive Output Rise and Fall Time

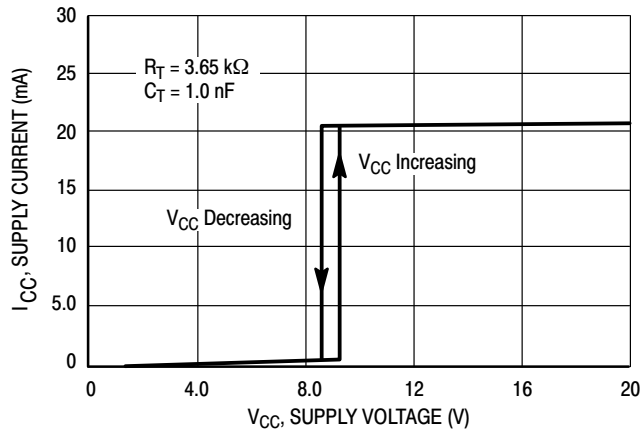

Figure 18. Supply Voltage versus Supply Current

MC34023, MC33023

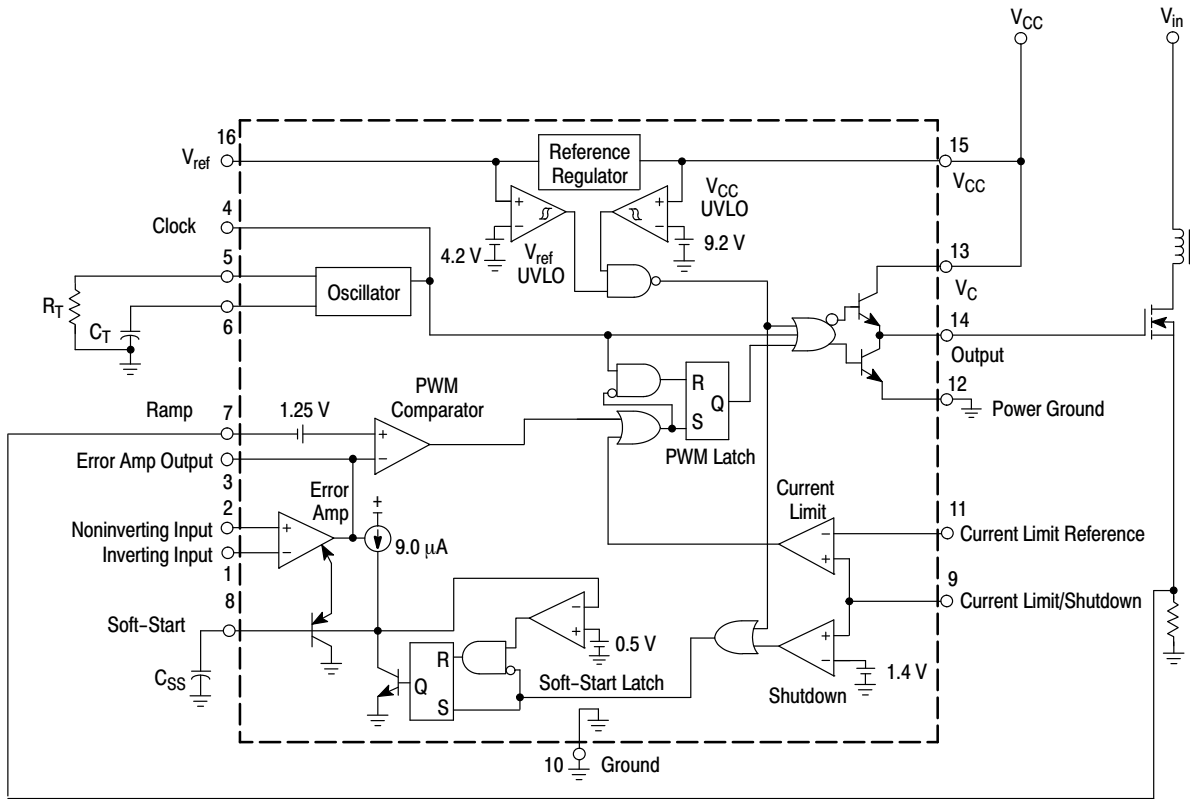

Figure 19. Representative Block Diagram

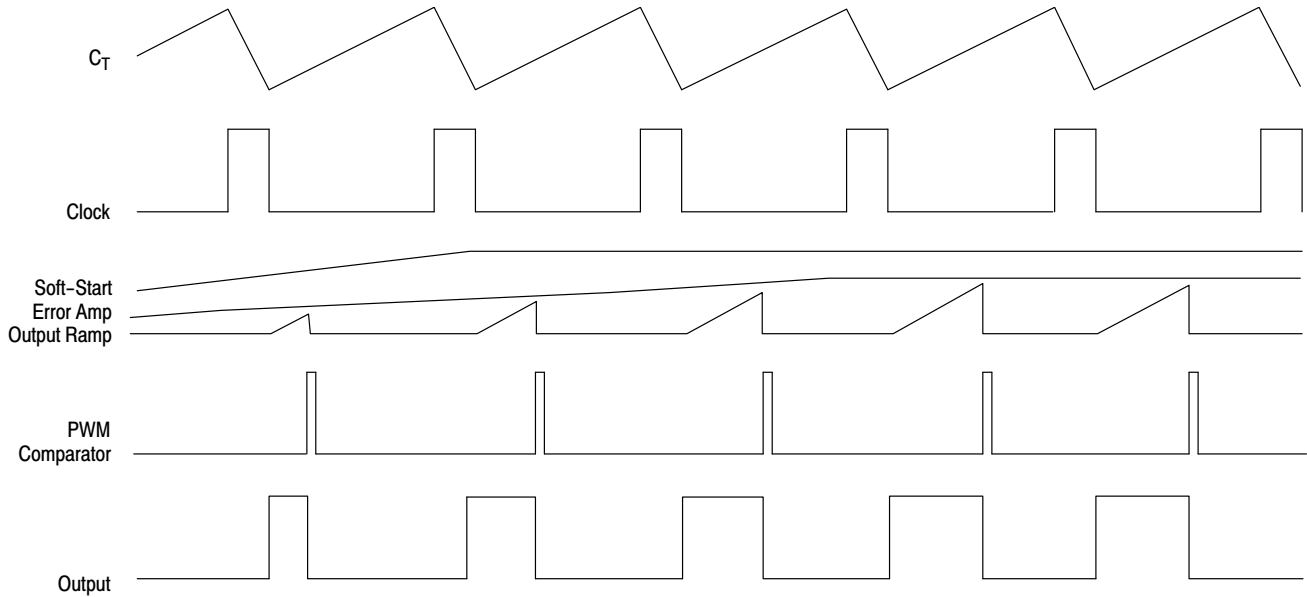

Figure 20. Current Limit Operating Waveforms

OPERATING DESCRIPTION

The MC33023 and MC34023 series are high speed, fixed frequency, single-ended pulse width modulator controllers optimized for high frequency operation. They are specifically designed for Off-Line and DC-to-DC converter applications offering the designer a cost effective solution with minimal external components. A representative block diagram is shown in Figure 19.

Oscillator

The oscillator frequency is programmed by the values selected for the timing components R_T and C_T . The R_T pin is set to a temperature compensated 3.0 V. By selecting the value of R_T , the charge current is set through a current mirror for the timing capacitor C_T . This charge current runs continuously through C_T . The discharge current is ratioed to be 10 times the charge current, which yields the maximum duty cycle of 90%. C_T is charged to 2.8 V and discharged to 1.0 V. During the discharge of C_T , the oscillator generates an internal blanking pulse that resets the PWM Latch and, inhibits the outputs. The threshold voltage on the oscillator comparator is trimmed to guarantee an oscillator accuracy of 5.0% at 25°C.

Additional dead time can be added by externally increasing the charge current to C_T as shown in Figure 24. This changes the charge to discharge ratio of C_T which is set internally to $I_{\text{charge}}/10 I_{\text{charge}}$. The new charge to discharge ratio will be:

$$\% \text{ Deadtime} = \frac{I_{\text{additional}} + I_{\text{charge}}}{10 (I_{\text{charge}})}$$

A bidirectional clock pin is provided for synchronization or for master/slave operation. As a master, the clock pin provides a positive output pulse during the discharge of C_T . As a slave, the clock pin is an input that resets the PWM latch and blanks the drive output, but does not discharge C_T . Therefore, the oscillator is not synchronized by driving the clock pin alone. Figures 28, 29 and 30 provide suggested synchronization.

Error Amplifier

A fully compensated Error Amplifier is provided. It features a typical DC voltage gain of 95 dB and a gain bandwidth product of 8.3 MHz with 75 degrees of phase margin (Figure 4). Typical application circuits will have the noninverting input tied to the reference. The inverting input will typically be connected to a feedback voltage generated from the output of the switching power supply. Both inputs have a common mode voltage (V_{CM}) input range of 1.5 V to 5.5 V. The Error Amplifier Output is provided for external loop compensation.

Soft-Start Latch

Soft-Start is accomplished in conjunction with an external capacitor. The Soft-Start capacitor is charged by an internal 9.0 μA current source. This capacitor clamps the

output of the error amplifier to less than its normal output voltage, thus limiting the duty cycle. The time it takes for a capacitor to reach full charge is given by:

$$t \approx (4.5 \cdot 10^5) C_{\text{Soft-Start}}$$

A Soft-Start latch is incorporated to prevent erratic operation of this circuitry. Two conditions can cause the Soft-Start circuit to latch so that the Soft-Start capacitor stays discharged. The first condition is activation of an undervoltage lockout of either V_{CC} or V_{ref} . The second condition is when current sense input exceeds 1.4 V. Since this latch is “set dominant”, it cannot be reset until either of these signals is removed and, the voltage at $C_{\text{Soft-Start}}$ is less than 0.5 V.

PWM Comparator and Latch

A PWM circuit typically compares an error voltage with a ramp signal. The outcome of this comparison determines the state of the output. In voltage mode operation the ramp signal is the voltage ramp of the timing capacitor. In current mode operation the ramp signal is the voltage ramp induced in a current sensing element. The ramp input of the PWM comparator is pinned out so that the user can decide which mode of operation best suits the application requirements. The ramp input has a 1.25 V offset such that whenever the voltage at this pin exceeds the error amplifier output voltage minus 1.25 V, the PWM comparator will cause the PWM latch to set, disabling the outputs. Once the PWM latch is set, only a blanking pulse by the oscillator can reset it, thus initiating the next cycle.

Current Limiting and Shutdown

A pin is provided to perform current limiting and shutdown operations. Two comparators are connected to the input of this pin. The reference voltage for the current limit comparator is not set internally. A pin is provided so the user can set the voltage. When the voltage at the current limit input pin exceeds the externally set voltage, the PWM latch is set, disabling the output. In this way cycle-by-cycle current limiting is accomplished. If a current limit resistor is used in series with the power devices, the value of the resistor is found by:

$$R_{\text{Sense}} = \frac{I_{\text{Limit Reference Voltage}}}{I_{\text{pk (switch)}}$$

If the voltage at this pin exceeds 1.4 V, the second comparator is activated. This comparator sets a latch which, in turn, causes the soft start capacitor to be discharged. In this way a “hiccup” mode of recovery is possible in the case of output short circuits. If a current limit resistor is used in series with the output devices, the peak current at which the controller will enter a “hiccup” mode is given by:

$$I_{\text{shutdown}} = \frac{1.4 \text{ V}}{R_{\text{Sense}}}$$

In certain applications, it may be desirable to disable the current limit comparator. This can be accomplished by biasing pin 11 to a level greater than 1.4 V but less than 3.0 V. Under these conditions, the shutdown comparator and soft-start latch are activated during an overcurrent event causing the converter to enter an hiccup mode.

Undervoltage Lockout

There are two undervoltage lockout circuits within the IC. The first senses V_{CC} and the second V_{ref} . During power-up, V_{CC} must exceed 9.2 V and V_{ref} must exceed 4.2 V before the outputs can be enabled and the Soft-Start latch released. If V_{CC} falls below 8.4 V or V_{ref} falls below 3.6 V, the outputs are disabled and the Soft-Start latch is activated. When the UVLO is active, the part is in a low current standby mode allowing the IC to have an off-line bootstrap startup circuit. Typical startup current is 500 μA .

Output

The MC34023 has a high current totem pole output specifically designed for direct drive of power MOSFETs. It is capable of up to $\pm 2.0 \text{ A}$ peak drive current with a typical rise and fall time of 30 ns driving a 1.0 nF load.

Separate pins for V_C and Power Ground are provided. With proper implementation, a significant reduction of switching transient noise imposed on the control circuitry is possible. The separate V_C supply input also allows the designer added flexibility in tailoring the drive voltage independent of V_{CC} .

Reference

A 5.1 V bandgap reference is pinned out and is trimmed to an initial accuracy of $\pm 1.0\%$ at 25°C. This reference has short circuit protection and can source in excess of 10 mA for powering additional control system circuitry.

Design Considerations

Do not attempt to construct the converter on wire-wrap or plug-in prototype boards. With high frequency, high power, switching power supplies it is imperative to have separate current loops for the signal paths and for the power paths. The printed circuit layout should contain a ground plane with low current signal and high current switch and output grounds returning on separate paths back to the input filter capacitor. Shown in Figure 36 is a printed circuit layout of the application circuit. Note how the power and ground traces are run. All bypass capacitors

and snubbers should be connected as close as possible to the specific part in question. The PC board lead lengths must be less than 0.5 inches for effective bypassing for snubbing.

Instabilities

In current mode control, an instability can be encountered at any given duty cycle. The instability is caused by the current feedback loop. It has been shown that the instability is caused by a double pole at half the switching frequency. If an external ramp (S_e) is added to the on-time ramp (S_n) of the current-sense waveform, stability can be achieved.

One must be careful not to add too much ramp compensation. If too much is added the system will start to perform like a voltage mode regulator. All benefits of current mode control will be lost. Figure 26 is an example of one way in which external ramp compensation can be implemented.

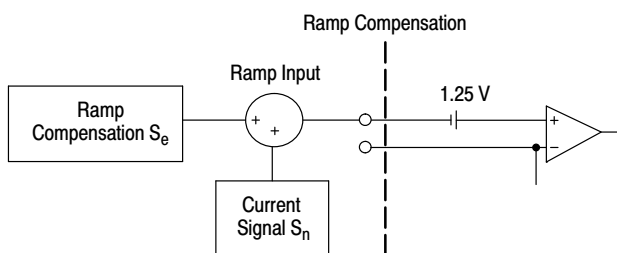

Figure 21. Ramp Compensation

A simple equation can be used to calculate the amount of external ramp slope necessary to add that will achieve stability in the current loop. For the following equations, the calculated values for the application circuit in Figure 35 are also shown.

$$S_e = \frac{V_O}{L} \left(\frac{N_S}{N_P} \right) (R_S) A_i$$

- where:
- V_O = DC output voltage
 - N_P, N_S = number of power transformer primary or secondary turns
 - A_i = gain of the current sense network (see Figures 24 and 25)
 - L = output inductor
 - R_S = current sense resistance

For the application circuit:
$$S_e = \frac{5}{1.8 \mu} \left(\frac{2}{8} \right) (0.3) (0.55) = 0.115 \text{ V/ms}$$

MC34023, MC33023

PIN FUNCTION DESCRIPTION

Pin	Function	Description
1	Error Amp Inverting Input	This pin is usually used for feedback from the output of the power supply.
2	Error Amp Noninverting Input	This pin is used to provide a reference in which an error signal can be produced on the output of the error amp. Usually this is connected to V_{ref} , however an external reference can also be used.
3	Error Amp Output	This pin is provided for compensating the error amp for poles and zeros encountered in the power supply system, mostly the output LC filter.
4	Clock	This is a bidirectional pin used for synchronization.
5	R_T	The value of R_T sets the charge current through timing Capacitor, C_T .
6	C_T	In conjunction with R_T , the timing Capacitor sets the switching frequency.
7	Ramp Input	For voltage mode operation this pin is connected to C_T . For current mode operation this pin is connected through a filter to the current sensing element.
8	Soft-Start	A capacitor at this pin sets the Soft-Start time.
9	Current Limit/Shutdown	This pin has two functions. First, it provides cycle-by-cycle current limiting. Second, if the current is excessive, this pin will reinitiate a Soft-Start cycle.
10	Ground	This pin is the ground for the control circuitry.
11	Current Limit Reference Input	This pin voltage sets the threshold for cycle-by-cycle current limiting.
12	Power Ground	This is a separate power ground return that is connected back to the power source. It is used to reduce the effects of switching transient noise on the control circuitry.
13	V_C	This is a separate power source connection for the outputs that is connected back to the power source input. With a separate power source connection, it can reduce the effects of switching transient noise on the control circuitry.
14	Output	This is a high current totem pole output.
15	V_{CC}	This pin is the positive supply of the control IC.
16	V_{ref}	This is a 5.1 V reference. It is usually connected to the noninverting input of the error amplifier.

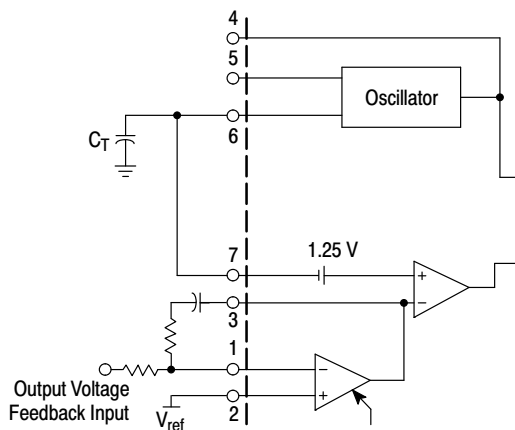

In voltage mode operation, the control range on the output of the Error Amplifier from 0% to 90% duty cycle is from 2.25 V to 4.05 V.

Figure 22. Voltage Mode Operation

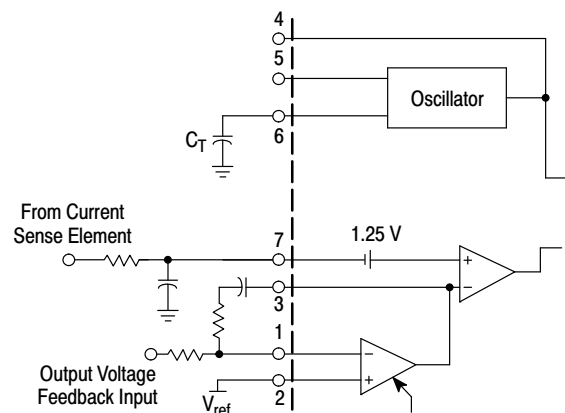

In current mode control, an RC filter should be placed at the ramp input to filter the leading edge spike caused by turn-on of a power MOSFET.

Figure 23. Current Mode Operation

MC34023, MC33023

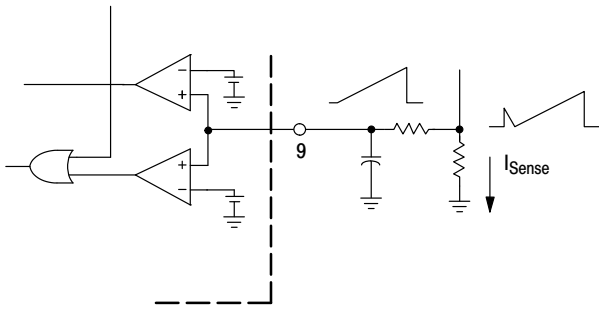

The addition of an RC filter will eliminate instability caused by the leading edge spike on the current waveform. This sense signal can also be used at the ramp input pin for current mode control. For ramp compensation it is necessary to know the gain of the current feedback loop. If a transformer is used, the gain can be calculated by:

$$A_i = \frac{R_{\text{Sense}}}{\text{turns ratio}}$$

Figure 24. Resistive Current Sensing

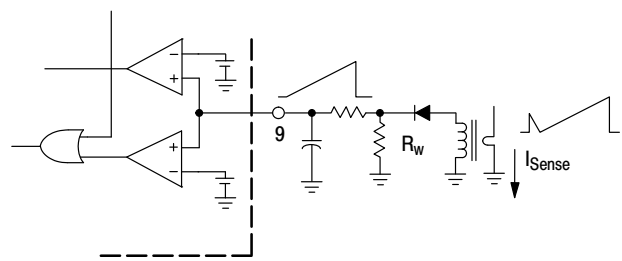

The addition of an RC filter will eliminate instability caused by the leading edge spike on the current waveform. This sense signal can also be used at the ramp input pin for current mode control. For ramp compensation it is necessary to know the gain of the current feedback loop. The gain can be calculated by:

$$A_i = \frac{R_w}{\text{turns ratio}}$$

Figure 25. Primary Side Current Sensing

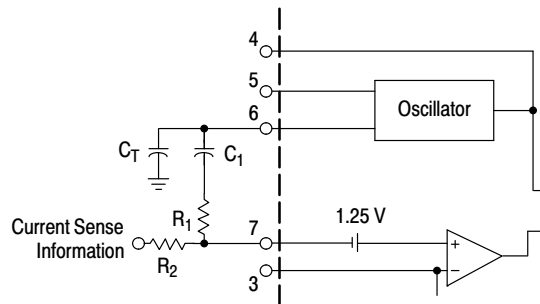

This method of slope compensation is easy to implement, however, it is noise sensitive. Capacitor C_1 provides AC coupling. The oscillator signal is added to the current signal by a voltage divider consisting of resistors R_1 and R_2 .

Figure 26A. Slope Compensation (Noise Sensitive)

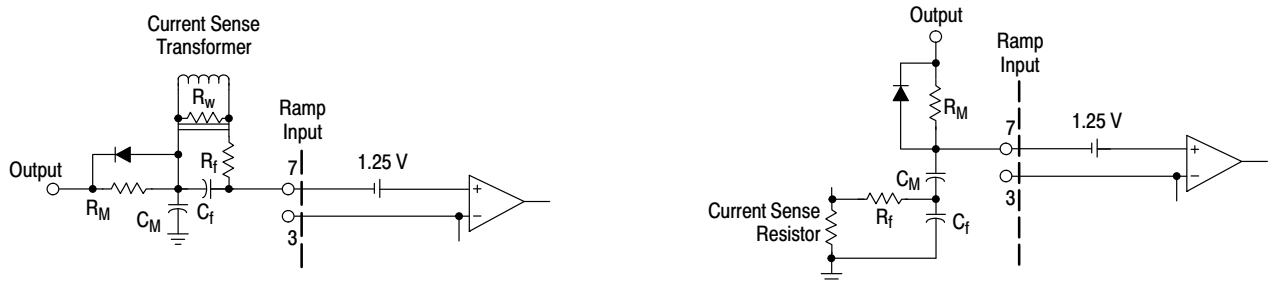

When only one output is used, this method of slope compensation can be used and it is relatively noise immune. Resistor R_M and capacitor C_M provide the added slope necessary. By choosing R_M and C_M with a larger time constant than the switching frequency, you can assume that its charge is linear. First choose C_M , then R_M can be adjusted to achieve the required slope. The diode provides a reset pulse at the ramp input at the end of every cycle. The charge current I_M can be calculated by $I_M = C_M S_e$. Then R_M can be calculated by $R_M = V_{CC}/I_M$.

Figure 26B. Slope Compensation (Noise Immune)

MC34023, MC33023

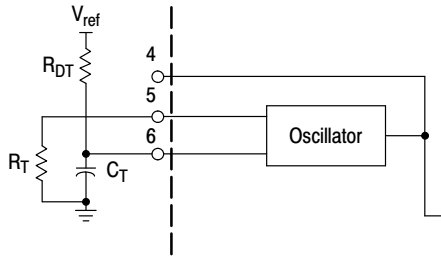

Additional dead time can be added by the addition of a dead time resistor from V_{ref} to C_T . See text on Oscillator section for more information.

Figure 27. Dead Time Addition

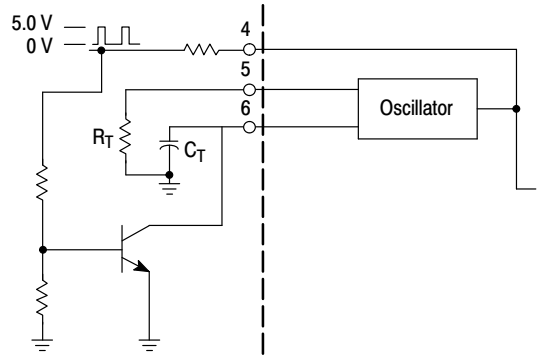

The sync pulse fed into the clock pin must be at least 3.9 V. R_T and C_T need to be set 10% slower than the sync frequency. This circuit is also used in Voltage Mode operation for master/slave operation. The clock signal would be coming from the master which is set at the desired operating frequency, while the slave is set 10% slower.

Figure 28. External Clock Synchronization

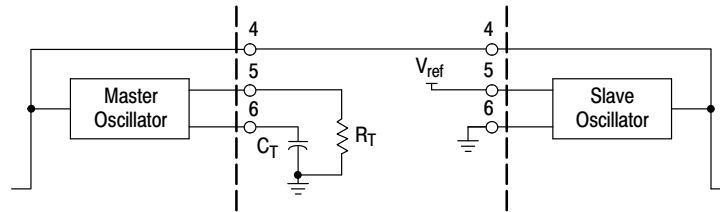

Figure 29. Current Mode Master/Slave Operation Over Short Distances

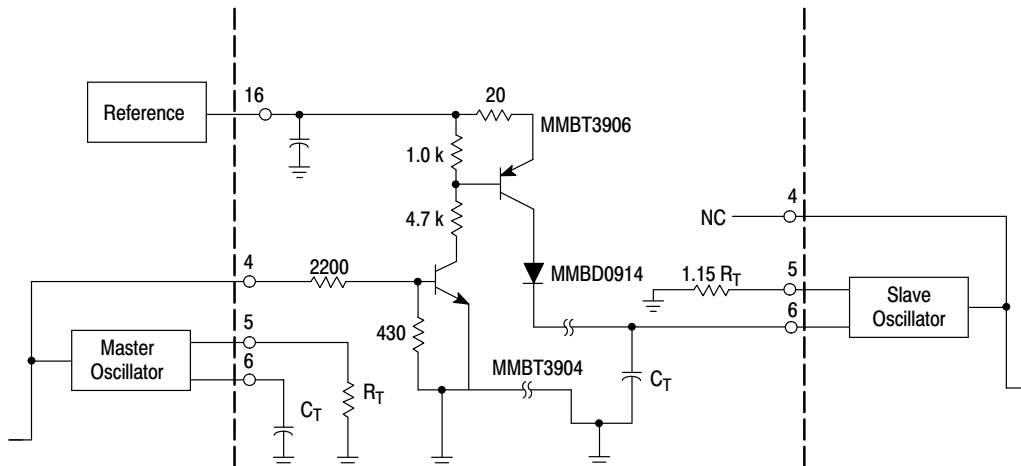
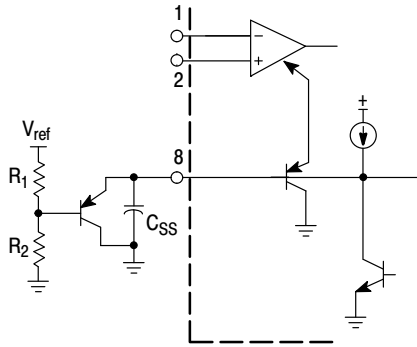

Figure 30. Synchronization Over Long Distances



In voltage mode operation, the maximum duty cycle can be clamped. By the addition of a PNP transistor to buffer the clamp voltage, the Soft-Start current is not affected by R_1 .

$$\text{The new equation for Soft-Start is } t \approx \frac{V_{\text{clamp}} + 0.6}{9.0 \mu\text{A}} (C_{\text{SS}})$$

In current mode operation, this circuit will limit the maximum voltage allowed at the ramp input to end a cycle.

Figure 31. Buffered Maximum Clamp Level

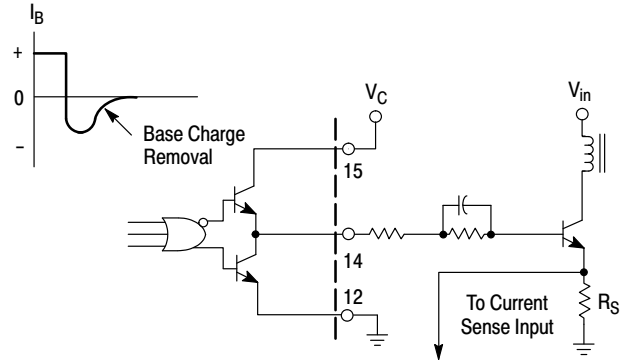

The totem pole output can furnish negative base current for enhanced transistor turn-off, with the addition of the capacitor in series with the base.

Figure 32. Bipolar Transistor Drive

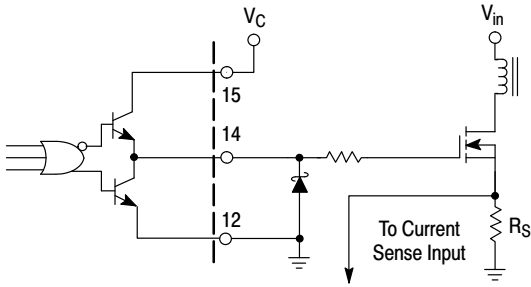

A series gate resistor may be needed to dampen high frequency parasitic oscillation caused by the MOSFET's input capacitance and any series wiring inductance in the gate-source circuit. The series resistor will also decrease the MOSFET switching speed. A Schottky diode can reduce the driver's power dissipation due to excessive ringing, by preventing the output pin from being driven below ground. The Schottky diode also prevents substrate injection when the output pin is driven below ground.

Figure 33. MOSFET Parasitic Oscillations

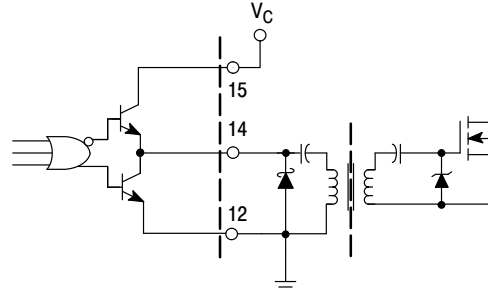

The totem pole output can easily drive pulse transformers. A Schottky diode is recommended when driving inductive loads at high frequencies. The diode can reduce the driver's power dissipation due to excessive ringing, by preventing the output pin from being driven below ground.

Figure 34. Isolated MOSFET Drive

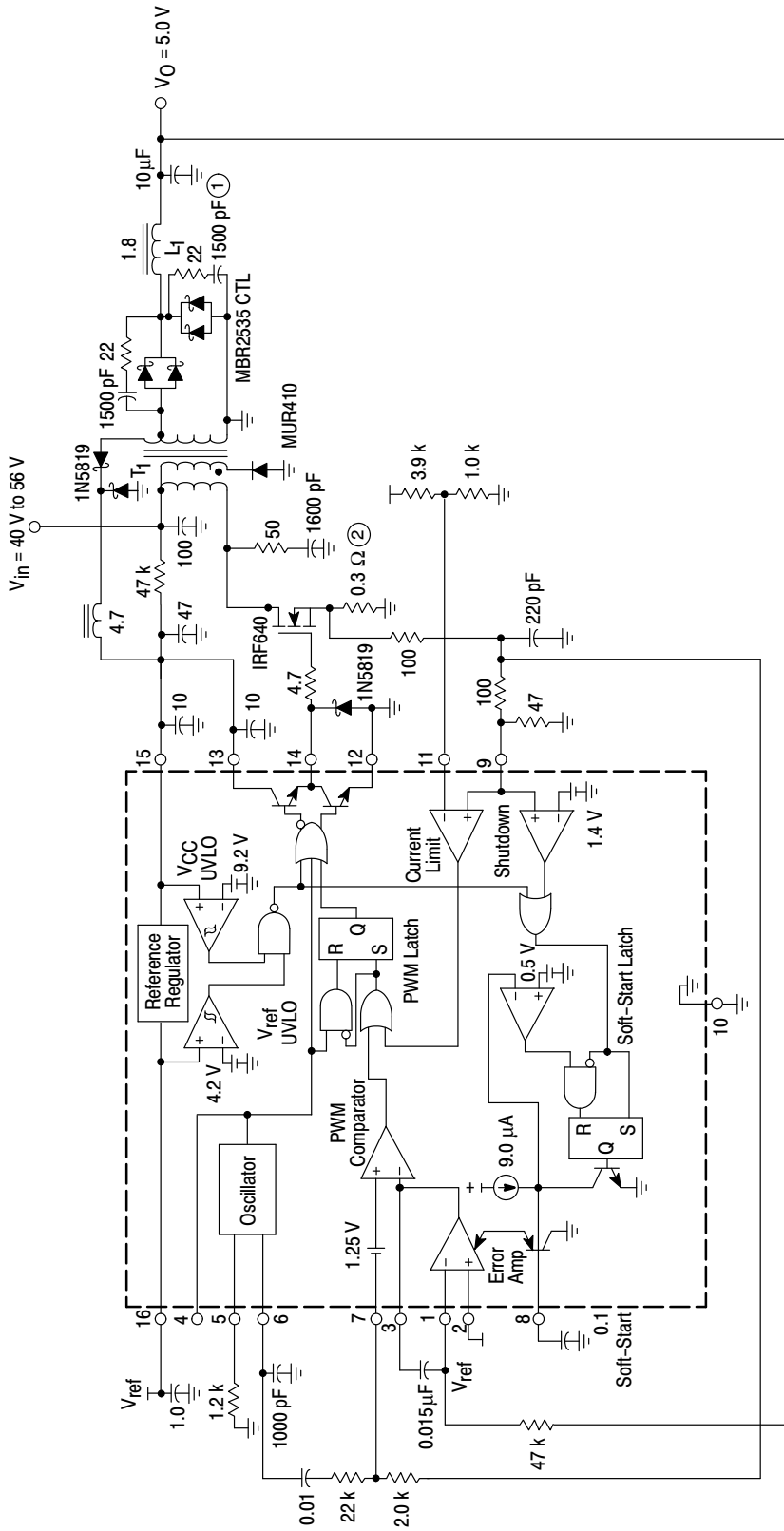

Figure 35. Application Circuit

T₁ - Primary: 8 turns #48 AWG (1300 strands litz wire)
 Secondary: 2 turns 0.003" (2 layers) copper foil
 Bootstraps: 1 turn added to secondary #56 AWG
 Core: Philips 3F3, part #4312 020 4124
 Bobbin: Philips part #4322 021 3525
 Coilcraft P3269-A

L₁ - 2 turns #48 AWG (1300 strands litz wire)
 Core: Philips 3F3, part #EP10-3F3
 Bobbin: Philips part #EP10PCB1-8
 L = 1.8 µH
 Coilcraft P3270-A

Heatsinks - Power FET: AAVID Heatsink #533902B02552 with clip
 Output Rectifiers: AAVID Heatsink #533402B02552 with clip
 Insulators - All power devices are insulated with Berquist Sil-Pad 150

① - 10(1.0 µF) ceramic capacitors in parallel
 ② - 5(1.5 Ω) resistors in parallel

Test	Condition	Result
Line Regulation	V _{in} = 40 V to 56 V, I _O = 7.5A	14 mV = ±0.275%
Load Regulation	V _{in} = 48 V, I _O = 4.0 A to 7.5 A	54 mV = ±1.0%
Output Ripple	V _{in} = 48 V, I _O = 7.5 A	10 mVp-p
Efficiency	V _{in} = 48 V, I _O = 7.5 A	69.8%

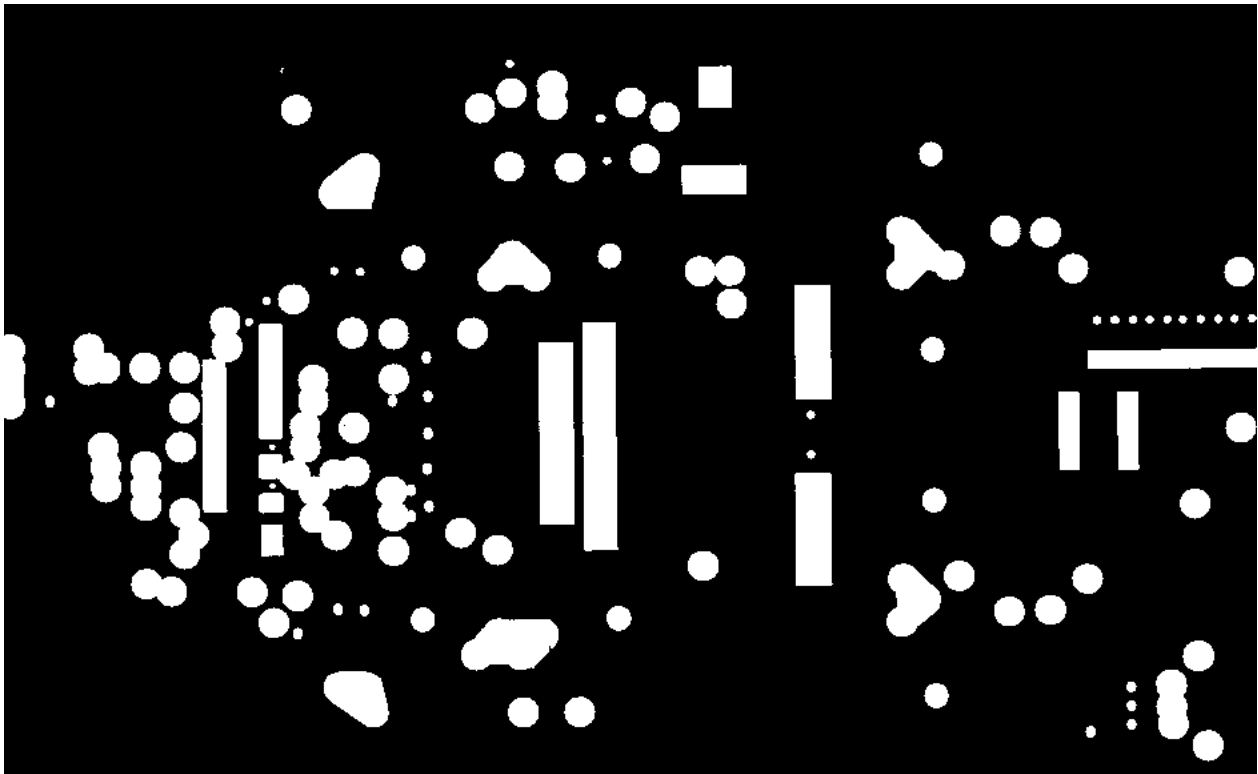

(Top View)

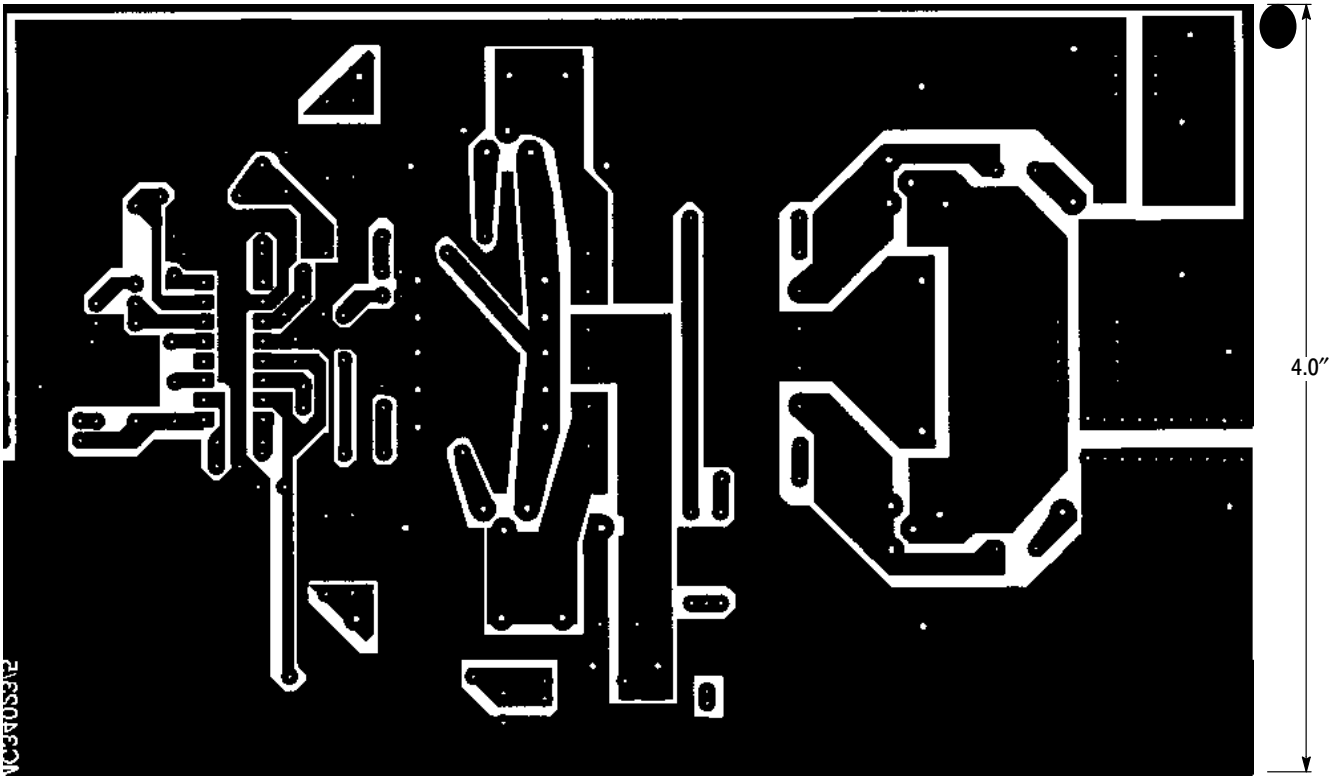

6.5"
(Bottom View)

Figure 37. PC Board Without Components

MC34023, MC33023

PACKAGE DIMENSIONS

PDIP-16 P SUFFIX CASE 648-08 ISSUE T

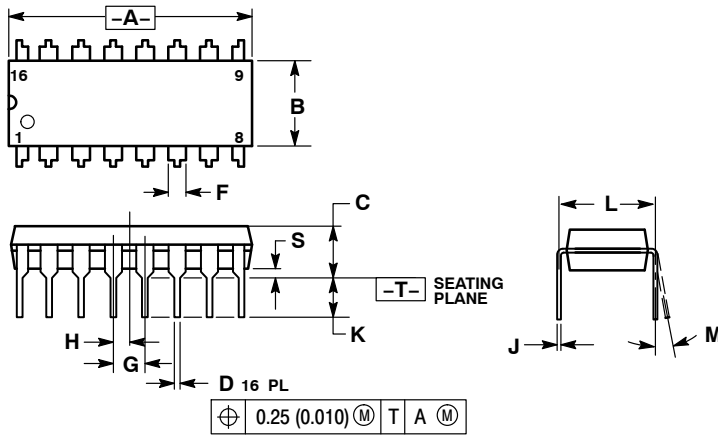

NOTES:

1. DIMENSIONING AND TOLERANCING PER ANSI Y14.5M, 1982.
2. CONTROLLING DIMENSION: INCH.
3. DIMENSION L TO CENTER OF LEADS WHEN FORMED PARALLEL.
4. DIMENSION B DOES NOT INCLUDE MOLD FLASH.
5. ROUNDED CORNERS OPTIONAL.

DIM	INCHES		MILLIMETERS	
	MIN	MAX	MIN	MAX
A	0.740	0.770	18.80	19.55
B	0.250	0.270	6.35	6.85
C	0.145	0.175	3.69	4.44
D	0.015	0.021	0.39	0.53
F	0.040	0.70	1.02	1.77
G	0.100 BSC		2.54 BSC	
H	0.050 BSC		1.27 BSC	
J	0.008	0.015	0.21	0.38
K	0.110	0.130	2.80	3.30
L	0.295	0.305	7.50	7.74
M	0°	10°	0°	10°
S	0.020	0.040	0.51	1.01

SOIC-16W DW SUFFIX CASE 751G-03 ISSUE C

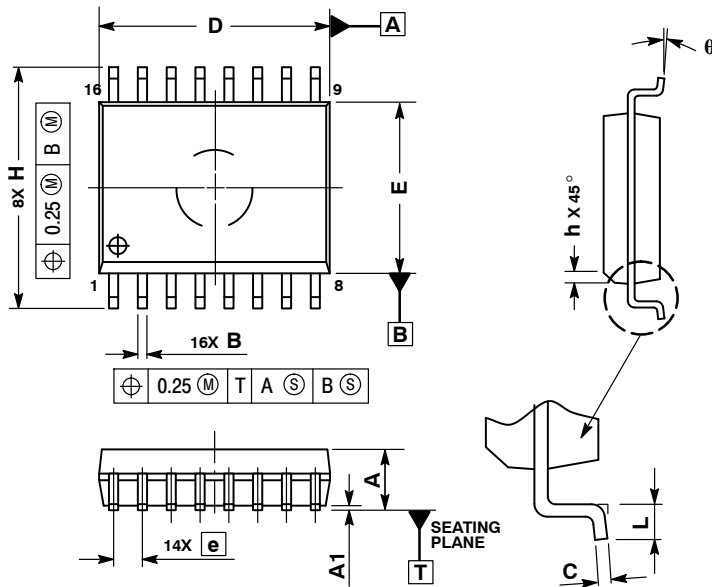

NOTES:

1. DIMENSIONS ARE IN MILLIMETERS.
2. INTERPRET DIMENSIONS AND TOLERANCES PER ASME Y14.5M, 1994.
3. DIMENSIONS D AND E DO NOT INCLUDE MOLD PROTRUSION.
4. MAXIMUM MOLD PROTRUSION 0.15 PER SIDE.
5. DIMENSION B DOES NOT INCLUDE DAMBAR PROTRUSION. ALLOWABLE DAMBAR PROTRUSION SHALL BE 0.13 TOTAL IN EXCESS OF THE B DIMENSION AT MAXIMUM MATERIAL CONDITION.

DIM	MILLIMETERS	
	MIN	MAX
A	2.35	2.65
A1	0.10	0.25
B	0.35	0.49
C	0.23	0.32
D	10.15	10.45
E	7.40	7.60
e		1.27 BSC
H	10.05	10.55
h	0.25	0.75
L	0.50	0.90
q	0°	7°

ON Semiconductor and are registered trademarks of Semiconductor Components Industries, LLC (SCILLC). SCILLC reserves the right to make changes without further notice to any products herein. SCILLC makes no warranty, representation or guarantee regarding the suitability of its products for any particular purpose, nor does SCILLC assume any liability arising out of the application or use of any product or circuit, and specifically disclaims any and all liability, including without limitation special, consequential or incidental damages. "Typical" parameters which may be provided in SCILLC data sheets and/or specifications can and do vary in different applications and actual performance may vary over time. All operating parameters, including "Typicals" must be validated for each customer application by customer's technical experts. SCILLC does not convey any license under its patent rights nor the rights of others. SCILLC products are not designed, intended, or authorized for use as components in systems intended for surgical implant into the body, or other applications intended to support or sustain life, or for any other application in which the failure of the SCILLC product could create a situation where personal injury or death may occur. Should Buyer purchase or use SCILLC products for any such unintended or unauthorized application, Buyer shall indemnify and hold SCILLC and its officers, employees, subsidiaries, affiliates, and distributors harmless against all claims, costs, damages, and expenses, and reasonable attorney fees arising out of, directly or indirectly, any claim of personal injury or death associated with such unintended or unauthorized use, even if such claim alleges that SCILLC was negligent regarding the design or manufacture of the part. SCILLC is an Equal Opportunity/Affirmative Action Employer. This literature is subject to all applicable copyright laws and is not for resale in any manner.

PUBLICATION ORDERING INFORMATION

LITERATURE FULFILLMENT:

Literature Distribution Center for ON Semiconductor
P.O. Box 5163, Denver, Colorado 80217 USA
Phone: 303-675-2175 or 800-344-3860 Toll Free USA/Canada
Fax: 303-675-2176 or 800-344-3867 Toll Free USA/Canada
Email: orderlit@onsemi.com

N. American Technical Support: 800-282-9855 Toll Free USA/Canada
Europe, Middle East and Africa Technical Support:
Phone: 421 33 790 2910
Japan Customer Focus Center
Phone: 81-3-5773-3850

ON Semiconductor Website: www.onsemi.com

Order Literature: <http://www.onsemi.com/orderlit>

For additional information, please contact your local Sales Representative

Looking for pricing, stock, or lifecycle information?

Click below to explore more details on WIN SOURCE:

⊖ [View MC33023DWR2G on WIN SOURCE](#)

⊖ [ON Semiconductor](#) Information

Optimize Your Supply Chain with WIN SOURCE Solutions

- ✓ Global Sourcing Solution
- ✓ Obsolete Management
- ✓ Cost Control Management
- ✓ Shortage Management
- ✓ Alternative Solution
- ✓ Excess Inventory Management