



**THE DATASHEET OF  
MC14511BDG**



# MC14511B

## BCD-to-Seven Segment Latch/Decoder/Driver

The MC14511B BCD-to-seven segment latch/decoder/driver is constructed with complementary MOS (CMOS) enhancement mode devices and NPN bipolar output drivers in a single monolithic structure. The circuit provides the functions of a 4-bit storage latch, an 8421 BCD-to-seven segment decoder, and an output drive capability. Lamp test ( $\overline{LT}$ ), blanking ( $\overline{BI}$ ), and latch enable (LE) inputs are used to test the display, to turn-off or pulse modulate the brightness of the display, and to store a BCD code, respectively. It can be used with seven-segment light-emitting diodes (LED), incandescent, fluorescent, gas discharge, or liquid crystal readouts either directly or indirectly.

Applications include instrument (e.g., counter, DVM, etc.) display driver, computer/calculator display driver, cockpit display driver, and various clock, watch, and timer uses.

### Features

- Low Logic Circuit Power Dissipation
- High-Current Sourcing Outputs (Up to 25 mA)
- Latch Storage of Code
- Blanking Input
- Lamp Test Provision
- Readout Blanking on all Illegal Input Combinations
- Lamp Intensity Modulation Capability
- Time Share (Multiplexing) Facility
- Supply Voltage Range = 3.0 V to 18 V
- Capable of Driving Two Low-power TTL Loads, One Low-power Schottky TTL Load, or Two HTL Loads Over the Rated Temperature Range
- Chip Complexity: 216 FETs or 54 Equivalent Gates
- Triple Diode Protection on all Inputs
- NLV Prefix for Automotive and Other Applications Requiring Unique Site and Control Change Requirements; AEC-Q100 Qualified and PPAP Capable
- These Devices are Pb-Free and are RoHS Compliant

### MAXIMUM RATINGS (Voltages Referenced to $V_{SS}$ ) (Note 1)

Symbol	Parameter	Value	Unit
$V_{DD}$	DC Supply Voltage Range	-0.5 to +18.0	V
$V_{in}$	Input Voltage Range, All Inputs	-0.5 to $V_{DD} + 0.5$	V
I	DC Current Drain per Input Pin	10	mA
$P_D$	Power Dissipation, per Package (Note 2)	500	mW
$T_A$	Operating Temperature Range	-55 to +125	°C
$T_{stg}$	Storage Temperature Range	-65 to +150	°C
$I_{OHmax}$	Maximum Output Drive Current (Source) per Output	25	mA
$P_{OHmax}$	Maximum Continuous Output Power (Source) per Output (Note 3)	50	mA

Stresses exceeding those listed in the Maximum Ratings table may damage the device. If any of these limits are exceeded, device functionality should not be assumed, damage may occur and reliability may be affected.

1. Maximum Ratings are those values beyond which damage to the device may occur.
2. Temperature Derating: "D/DW" Packages: -7.0 mW/°C From 65°C to 125°C
3.  $P_{OHmax} = I_{OH} (V_{DD} - V_{OH})$



ON Semiconductor®

<http://onsemi.com>

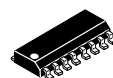

SOIC-16  
D SUFFIX  
CASE 751B



SOEIAJ-16  
F SUFFIX  
CASE 966

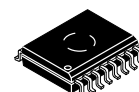

SO-16 WB  
DW SUFFIX  
CASE 751G

### MARKING DIAGRAMS



SOIC-16

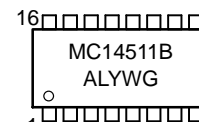

SOEIAJ-16

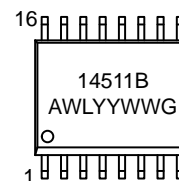

SO-16 WB

- A = Assembly Location
- WL, L = Wafer Lot
- YY, Y = Year
- WW, W = Work Week
- G = Pb-Free Package

### ORDERING INFORMATION

See detailed ordering and shipping information in the package dimensions section on page 7 of this data sheet.

# MC14511B

This device contains protection circuitry to protect the inputs against damage due to high static voltages or electric fields. However, it is advised that normal precautions be taken to avoid application of any voltage higher than maximum rated voltages to this high-impedance circuit. A destructive high current mode may occur if  $V_{in}$  and  $V_{out}$  are not constrained to the range  $V_{SS} \leq (V_{in} \text{ or } V_{out}) \leq V_{DD}$ .

Due to the sourcing capability of this circuit, damage can occur to the device if  $V_{DD}$  is applied, and the outputs are shorted to  $V_{SS}$  and are at a logical 1 (See Maximum Ratings).

Unused inputs must always be tied to an appropriate logic voltage level (e.g., either  $V_{SS}$  or  $V_{DD}$ ).

## PIN ASSIGNMENT

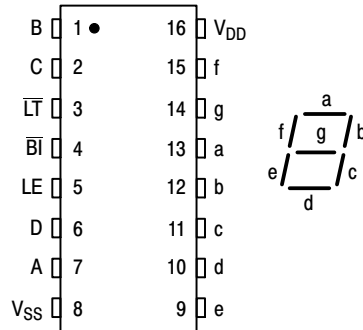

## DISPLAY

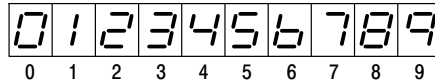

## TRUTH TABLE

Inputs							Outputs							
LE	BI	LT	D	C	B	A	a	b	c	d	e	f	g	Display
X	X	0	X	X	X	X	1	1	1	1	1	1	1	8
X	0	1	X	X	X	X	0	0	0	0	0	0	0	Blank
0	1	1	0	0	0	0	1	1	1	1	1	1	0	0
0	1	1	0	0	0	1	0	1	1	0	0	0	0	1
0	1	1	0	0	1	0	1	1	0	1	1	0	1	2
0	1	1	0	0	1	1	1	1	1	1	0	0	1	3
0	1	1	0	1	0	0	0	1	1	0	0	1	1	4
0	1	1	0	1	0	1	1	0	1	1	0	1	1	5
0	1	1	0	1	1	0	0	0	1	1	1	1	1	6
0	1	1	0	1	1	1	1	1	1	0	0	0	0	7
0	1	1	1	0	0	0	1	1	1	1	1	1	1	8
0	1	1	1	0	0	1	1	1	1	0	0	1	1	9
0	1	1	1	0	1	0	0	0	0	0	0	0	0	Blank
0	1	1	1	0	1	1	0	0	0	0	0	0	0	Blank
0	1	1	1	1	0	0	0	0	0	0	0	0	0	Blank
0	1	1	1	1	1	0	0	0	0	0	0	0	0	Blank
0	1	1	1	1	1	1	0	0	0	0	0	0	0	Blank
1	1	1	X	X	X	X	*							*

X = Don't Care

\* Depends upon the BCD code previously applied when LE = 0

# MC14511B

## ELECTRICAL CHARACTERISTICS (Voltages Referenced to V<sub>SS</sub>)

Characteristic	Symbol	V <sub>DD</sub> Vdc	- 55°C		25°C			125°C		Unit		
			Min	Max	Min	Typ (Note 4)	Max	Min	Max			
Output Voltage V <sub>in</sub> = V <sub>DD</sub> or 0	"0" Level	V <sub>OL</sub>	5.0	–	0.05	–	0	0.05	–	0.05	Vdc	
			10	–	0.05	–	0	0.05	–	0.05		
15			–	0.05	–	0	0.05	–	0.05			
V <sub>in</sub> = 0 or V <sub>DD</sub>	"1" Level	V <sub>OH</sub>	5.0	4.1	–	4.1	4.57	–	4.1	–	Vdc	
			10	9.1	–	9.1	9.58	–	9.1	–		
			15	14.1	–	14.1	14.59	–	14.1	–		
Input Voltage # (V <sub>O</sub> = 3.8 or 0.5 Vdc) (V <sub>O</sub> = 8.8 or 1.0 Vdc) (V <sub>O</sub> = 13.8 or 1.5 Vdc)	"0" Level	V <sub>IL</sub>	5.0	–	1.5	–	2.25	1.5	–	1.5	Vdc	
			10	–	3.0	–	4.50	3.0	–	3.0		
			15	–	4.0	–	6.75	4.0	–	4.0		
(V <sub>O</sub> = 0.5 or 3.8 Vdc) (V <sub>O</sub> = 1.0 or 8.8 Vdc) (V <sub>O</sub> = 1.5 or 13.8 Vdc)	"1" Level	V <sub>IH</sub>	5.0	3.5	–	3.5	2.75	–	3.5	–	Vdc	
			10	7.0	–	7.0	5.50	–	7.0	–		
			15	11	–	11	8.25	–	11	–		
Output Drive Voltage (I <sub>OH</sub> = 0 mA) (I <sub>OH</sub> = 5.0 mA) (I <sub>OH</sub> = 10 mA) (I <sub>OH</sub> = 15 mA) (I <sub>OH</sub> = 20 mA) (I <sub>OH</sub> = 25 mA)	Source	V <sub>OH</sub>	5.0	4.1	–	4.1	4.57	–	4.1	–	Vdc	
				–	–	–	4.24	–	–	–		
				3.9	–	3.9	4.12	–	3.5	–		
				–	–	–	3.94	–	–	–		
				3.4	–	3.4	3.70	–	3.0	–		
				–	–	–	3.54	–	–	–		
				10	9.1	–	9.1	9.58	–	9.1	–	Vdc
				–	–	–	9.26	–	–	–		
				9.0	–	9.0	9.17	–	8.6	–		
				–	–	–	9.04	–	–	–		
				8.6	–	8.6	8.90	–	8.2	–		
				–	–	–	8.70	–	–	–		
			15	14.1	–	14.1	14.59	–	14.1	–	Vdc	
			–	–	–	14.27	–	–	–			
			14	–	14	14.18	–	13.6	–			
			–	–	–	14.07	–	–	–			
			13.6	–	13.6	13.95	–	13.2	–			
			–	–	–	13.70	–	–	–			
Output Drive Current (V <sub>OL</sub> = 0.4 V) (V <sub>OL</sub> = 0.5 V) (V <sub>OL</sub> = 1.5 V)	Sink	I <sub>OL</sub>	5.0	0.64	–	0.51	0.88	–	0.36	–	mAdc	
			10	1.6	–	1.3	2.25	–	0.9	–		
			15	4.2	–	3.4	8.8	–	2.4	–		
Input Current		I <sub>in</sub>	15	–	±0.1	–	±0.00001	±0.1	–	±1.0	μAdc	
Input Capacitance		C <sub>in</sub>	–	–	–	–	5.0	7.5	–	–	pF	
Quiescent Current (Per Package) V <sub>in</sub> = 0 or V <sub>DD</sub> , I <sub>out</sub> = 0 μA		I <sub>DD</sub>	5.0	–	5.0	–	0.005	5.0	–	150	μAdc	
			10	–	10	–	0.010	10	–	300		
			15	–	20	–	0.015	20	–	600		
Total Supply Current (Notes 5 & 6) (Dynamic plus Quiescent, Per Package) (C <sub>L</sub> = 50 pF on all outputs, all buffers switching)		I <sub>T</sub>	5.0	I <sub>T</sub> = (1.9 μA/kHz) f + I <sub>DD</sub>						μAdc		
			10	I <sub>T</sub> = (3.8 μA/kHz) f + I <sub>DD</sub>								
			15	I <sub>T</sub> = (5.7 μA/kHz) f + I <sub>DD</sub>								

Product parametric performance is indicated in the Electrical Characteristics for the listed test conditions, unless otherwise noted. Product performance may not be indicated by the Electrical Characteristics if operated under different conditions.

4. Noise immunity specified for worst-case input combination.

Noise Margin for both "1" and "0" level =

1.0 Vdc min @ V<sub>DD</sub> = 5.0 Vdc

2.0 Vdc min @ V<sub>DD</sub> = 10 Vdc

2.5 Vdc min @ V<sub>DD</sub> = 15 Vdc

5. The formulas given are for the typical characteristics only at 25°C.

6. To calculate total supply current at loads other than 50 pF:

$$I_T(C_L) = I_T(50 \text{ pF}) + 3.5 \times 10^{-3} (C_L - 50) V_{DD} f$$

where: I<sub>T</sub> is in μA (per package), C<sub>L</sub> in pF, V<sub>DD</sub> in Vdc, and f in kHz is input frequency.

# MC14511B

## SWITCHING CHARACTERISTICS (Note 7) ( $C_L = 50 \text{ pF}$ , $T_A = 25^\circ\text{C}$ )

Characteristic	Symbol	$V_{DD}$ Vdc	Min	Typ	Max	Unit
Output Rise Time $t_{TLH} = (0.40 \text{ ns/pF}) C_L + 20 \text{ ns}$ $t_{TLH} = (0.25 \text{ ns/pF}) C_L + 17.5 \text{ ns}$ $t_{TLH} = (0.20 \text{ ns/pF}) C_L + 15 \text{ ns}$	$t_{TLH}$	5.0 10 15	– – –	40 30 25	80 60 50	ns
Output Fall Time $t_{THL} = (1.5 \text{ ns/pF}) C_L + 50 \text{ ns}$ $t_{THL} = (0.75 \text{ ns/pF}) C_L + 37.5 \text{ ns}$ $t_{THL} = (0.55 \text{ ns/pF}) C_L + 37.5 \text{ ns}$	$t_{THL}$	5.0 10 15	– – –	125 75 65	250 150 130	ns
Data Propagation Delay Time $t_{PLH} = (0.40 \text{ ns/pF}) C_L + 620 \text{ ns}$ $t_{PLH} = (0.25 \text{ ns/pF}) C_L + 237.5 \text{ ns}$ $t_{PLH} = (0.20 \text{ ns/pF}) C_L + 165 \text{ ns}$ $t_{PHL} = (1.3 \text{ ns/pF}) C_L + 655 \text{ ns}$ $t_{PHL} = (0.60 \text{ ns/pF}) C_L + 260 \text{ ns}$ $t_{PHL} = (0.35 \text{ ns/pF}) C_L + 182.5 \text{ ns}$	$t_{PLH}$    $t_{PHL}$	5.0 10 15  5.0 10 15	– – –  – – –	640 250 175  720 290 200	1280 500 350  1440 580 400	ns
Blank Propagation Delay Time $t_{PLH} = (0.30 \text{ ns/pF}) C_L + 585 \text{ ns}$ $t_{PLH} = (0.25 \text{ ns/pF}) C_L + 187.5 \text{ ns}$ $t_{PLH} = (0.15 \text{ ns/pF}) C_L + 142.5 \text{ ns}$ $t_{PHL} = (0.85 \text{ ns/pF}) C_L + 442.5 \text{ ns}$ $t_{PHL} = (0.45 \text{ ns/pF}) C_L + 177.5 \text{ ns}$ $t_{PHL} = (0.35 \text{ ns/pF}) C_L + 142.5 \text{ ns}$	$t_{PLH}$    $t_{PHL}$	5.0 10 15  5.0 10 15	– – –  – – –	600 200 150  485 200 160	750 300 220  970 400 320	ns
Lamp Test Propagation Delay Time $t_{PLH} = (0.45 \text{ ns/pF}) C_L + 290.5 \text{ ns}$ $t_{PLH} = (0.25 \text{ ns/pF}) C_L + 112.5 \text{ ns}$ $t_{PLH} = (0.20 \text{ ns/pF}) C_L + 80 \text{ ns}$ $t_{PHL} = (1.3 \text{ ns/pF}) C_L + 248 \text{ ns}$ $t_{PHL} = (0.45 \text{ ns/pF}) C_L + 102.5 \text{ ns}$ $t_{PHL} = (0.35 \text{ ns/pF}) C_L + 72.5 \text{ ns}$	$t_{PLH}$    $t_{PHL}$	5.0 10 15  5.0 10 15	– – –  – – –	313 125 90  313 125 90	625 250 180  625 250 180	ns
Setup Time	$t_{su}$	5.0 10 15	100 40 30	– – –	– – –	ns
Hold Time	$t_h$	5.0 10 15	60 40 30	– – –	– – –	ns
Latch Enable Pulse Width	$t_{WL}$	5.0 10 15	520 220 130	260 110 65	– – –	ns

7. The formulas given are for the typical characteristics only.

# MC14511B

Input LE low, and Inputs D,  $\overline{BI}$  and  $\overline{LT}$  high.  
 $f$  in respect to a system clock.  
 All outputs connected to respective  $C_L$  loads.

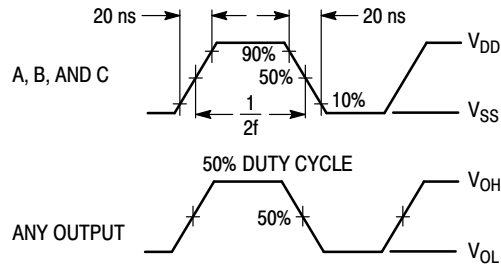
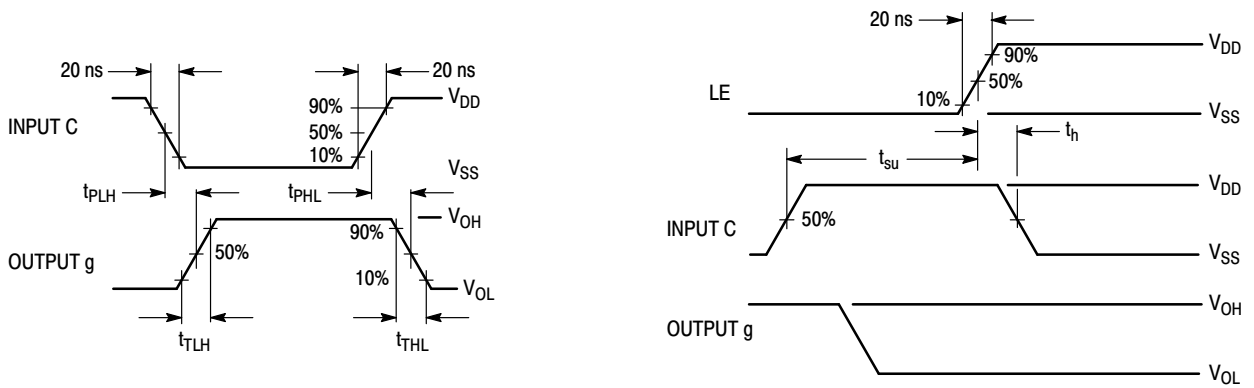
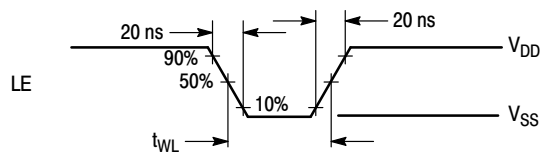

Figure 1. Dynamic Power Dissipation Signal Waveforms



(a) Inputs D and LE low, and  
 Inputs A, B,  $\overline{BI}$  and  $\overline{LT}$  high.

(b) Input D low,  
 Inputs A, B,  $\overline{BI}$  and  $\overline{LT}$  high.



(c) Data DCBA strobed into latches.

Figure 2. Dynamic Signal Waveforms

# MC14511B

## CONNECTIONS TO VARIOUS DISPLAY READOUTS

### LIGHT EMITTING DIODE (LED) READOUT

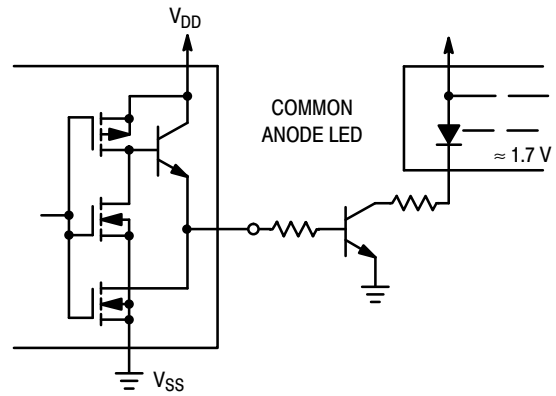
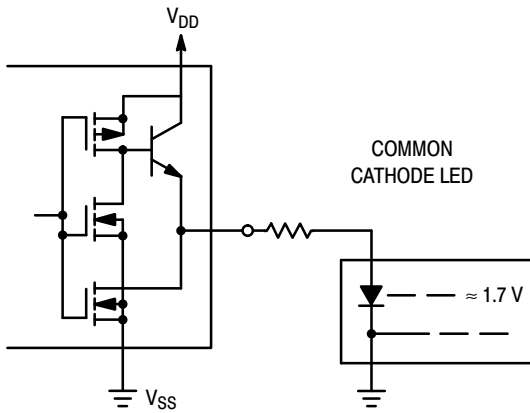

### INCANDESCENT READOUT

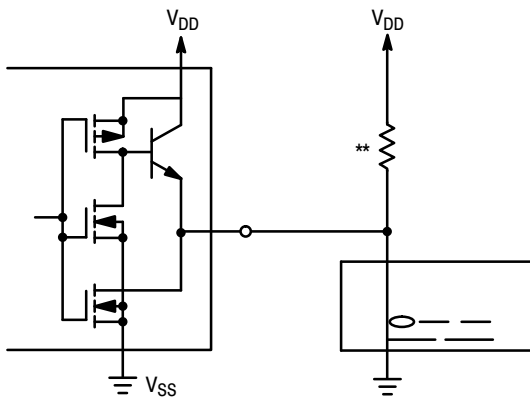

### FLUORESCENT READOUT

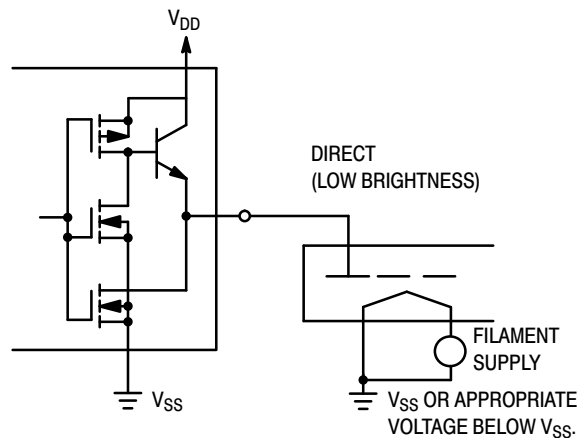

(CAUTION: Maximum working voltage = 18.0 V)

### GAS DISCHARGE READOUT

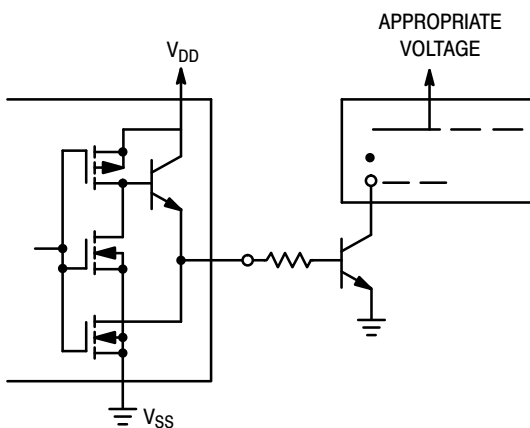

### LIQUID CRYSTAL (LCD) READOUT

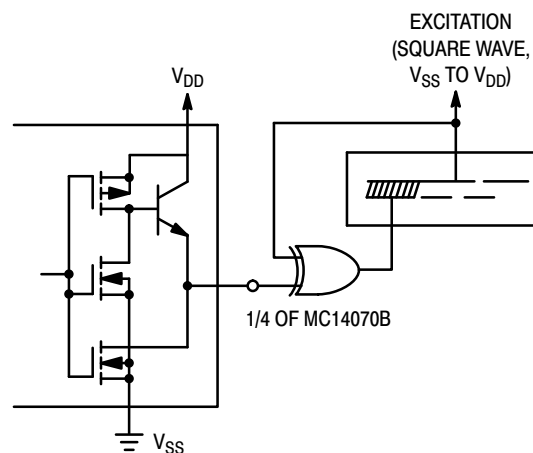

\*\* A filament pre-warm resistor is recommended to reduce filament thermal shock and increase the effective cold resistance of the filament.

Direct DC drive of LCD's not recommended for life of LCD readouts.

# MC14511B

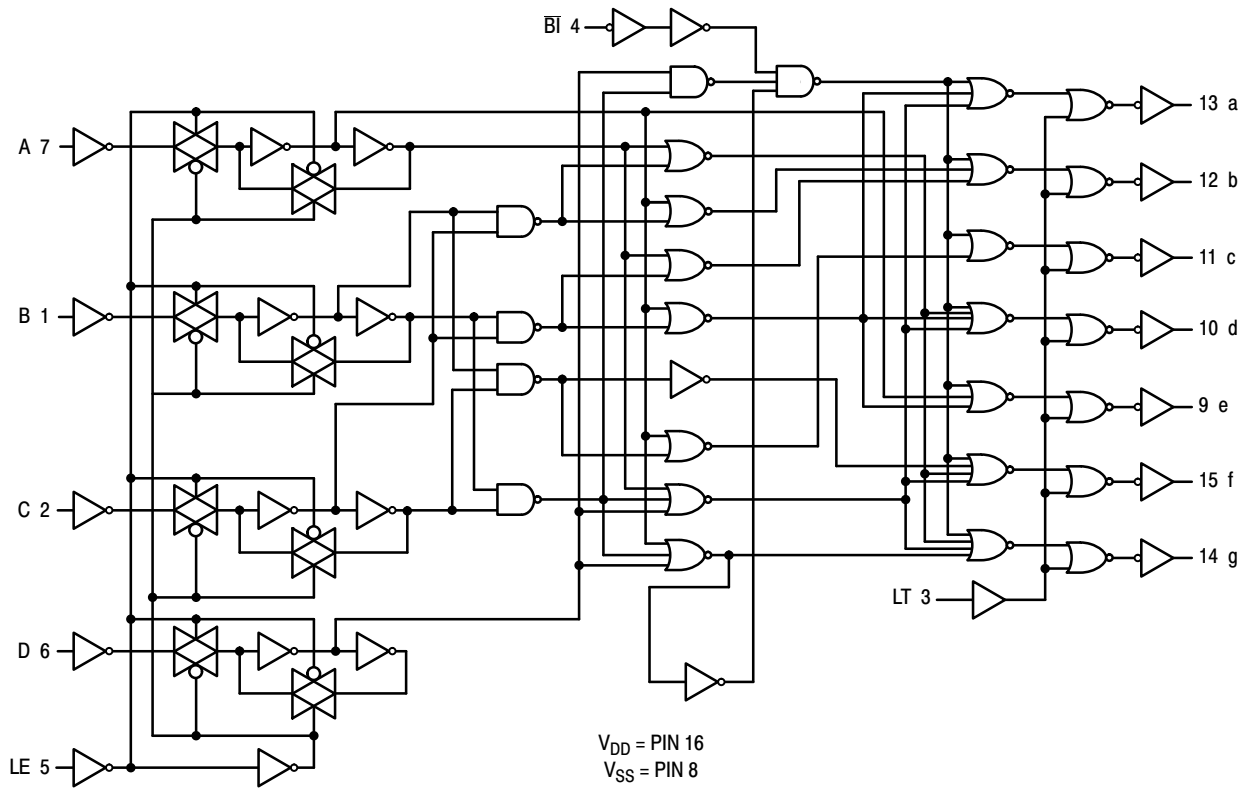

**Figure 3. Logic Diagram**

## ORDERING INFORMATION

Device	Package	Shipping†
MC14511BDG	SOIC-16 (Pb-Free)	48 Units / Rail
MC14511BDR2G	SOIC-16 (Pb-Free)	2500 / Tape & Reel
MC14511BDWR2G	SO-16 WB (Pb-Free)	1000 / Tape & Reel
NLV14511BDWR2G*	SO-16 WB (Pb-Free)	1000 / Tape & Reel
MC14511BFG	SOEIAJ-16 (Pb-Free)	50 Units / Rail
MC14511BFELG	SOEIAJ-16 (Pb-Free)	2000 / Tape & Reel

†For information on tape and reel specifications, including part orientation and tape sizes, please refer to our Tape and Reel Packaging Specifications Brochure, BRD8011/D.

\*NLV Prefix for Automotive and Other Applications Requiring Unique Site and Control Change Requirements; AEC-Q100 Qualified and PPAP Capable.

# MC14511B

## PACKAGE DIMENSIONS

SOIC-16  
 PLASTIC SOIC PACKAGE  
 CASE 751B-05  
 ISSUE K

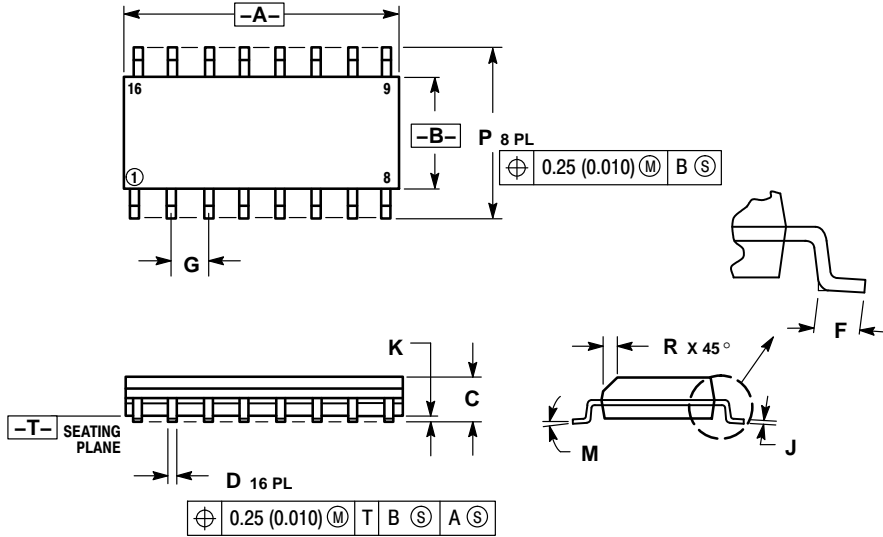

**NOTES:**

1. DIMENSIONING AND TOLERANCING PER ANSI Y14.5M, 1982.
2. CONTROLLING DIMENSION: MILLIMETER.
3. DIMENSIONS A AND B DO NOT INCLUDE MOLD PROTRUSION.
4. MAXIMUM MOLD PROTRUSION 0.15 (0.006) PER SIDE.
5. DIMENSION D DOES NOT INCLUDE DAMBAR PROTRUSION. ALLOWABLE DAMBAR PROTRUSION SHALL BE 0.127 (0.005) TOTAL IN EXCESS OF THE D DIMENSION AT MAXIMUM MATERIAL CONDITION.

DIM	MILLIMETERS		INCHES	
	MIN	MAX	MIN	MAX
A	9.80	10.00	0.386	0.393
B	3.80	4.00	0.150	0.157
C	1.35	1.75	0.054	0.068
D	0.35	0.49	0.014	0.019
F	0.40	1.25	0.016	0.049
G	1.27 BSC		0.050 BSC	
J	0.19	0.25	0.008	0.009
K	0.10	0.25	0.004	0.009
M	0°	7°	0°	7°
P	5.80	6.20	0.229	0.244
R	0.25	0.50	0.010	0.019

### SOLDERING FOOTPRINT

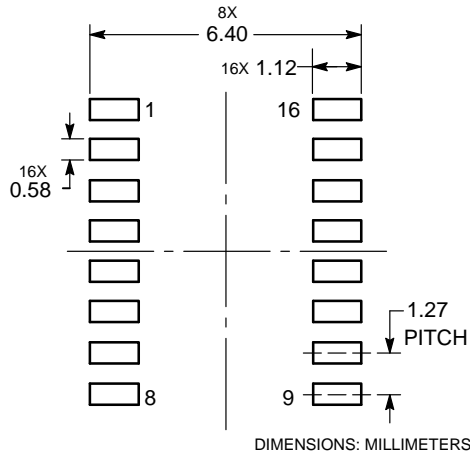

# MC14511B

## PACKAGE DIMENSIONS

SOIC-16 WB  
CASE 751G-03  
ISSUE D

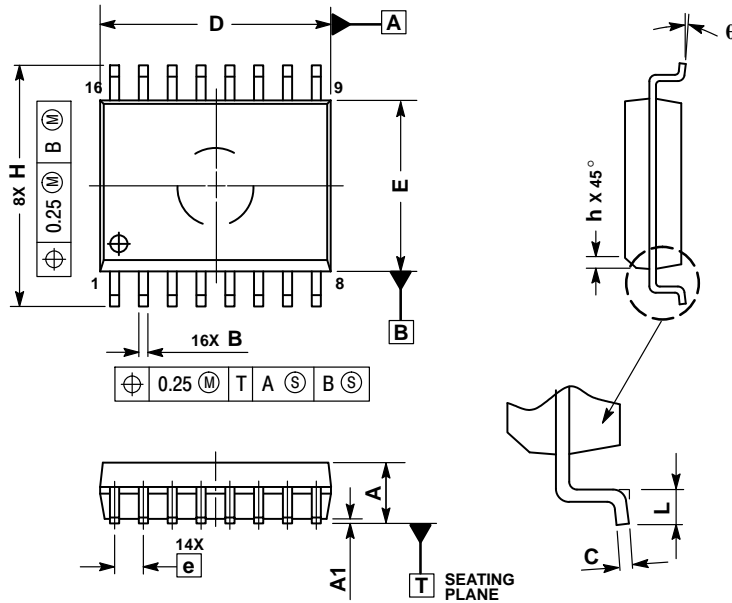

NOTES:

1. DIMENSIONS ARE IN MILLIMETERS.
2. INTERPRET DIMENSIONS AND TOLERANCES PER ASME Y14.5M, 1994.
3. DIMENSIONS D AND E DO NOT INCLUDE MOLD PROTRUSION.
4. MAXIMUM MOLD PROTRUSION 0.15 PER SIDE.
5. DIMENSION B DOES NOT INCLUDE DAMBAR PROTRUSION. ALLOWABLE DAMBAR PROTRUSION SHALL BE 0.13 TOTAL IN EXCESS OF THE B DIMENSION AT MAXIMUM MATERIAL CONDITION.

MILLIMETERS		
DIM	MIN	MAX
A	2.35	2.65
A1	0.10	0.25
B	0.35	0.49
C	0.23	0.32
D	10.15	10.45
E	7.40	7.60
e	1.27 BSC	
H	10.05	10.55
h	0.25	0.75
L	0.50	0.90
q	0°	7°

### SOLDERING FOOTPRINT

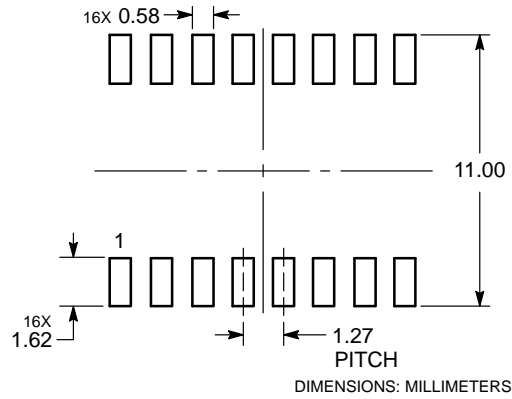

# MC14511B

## PACKAGE DIMENSIONS

SOEIAJ-16  
CASE 966  
ISSUE A

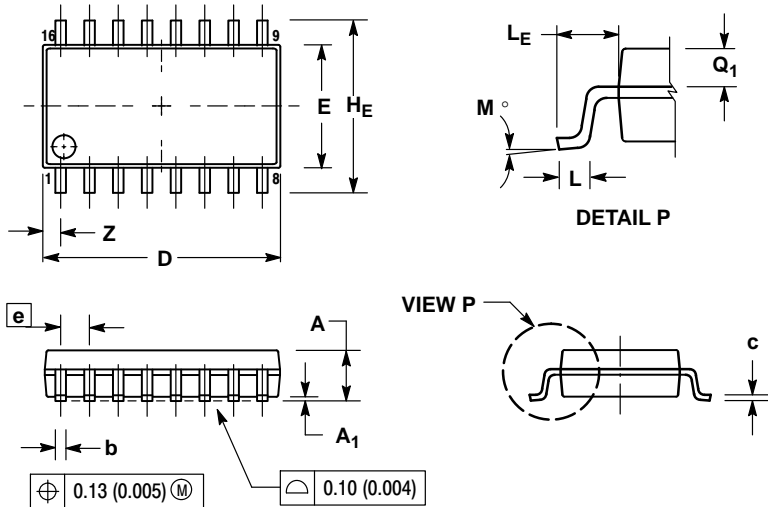

### NOTES:

1. DIMENSIONING AND TOLERANCING PER ANSI Y14.5M, 1982.
2. CONTROLLING DIMENSION: MILLIMETER.
3. DIMENSIONS D AND E DO NOT INCLUDE MOLD FLASH OR PROTRUSIONS AND ARE MEASURED AT THE PARTING LINE. MOLD FLASH OR PROTRUSIONS SHALL NOT EXCEED 0.15 (0.006) PER SIDE.
4. TERMINAL NUMBERS ARE SHOWN FOR REFERENCE ONLY.
5. THE LEAD WIDTH DIMENSION (b) DOES NOT INCLUDE DAMBAR PROTRUSION. ALLOWABLE DAMBAR PROTRUSION SHALL BE 0.08 (0.003) TOTAL IN EXCESS OF THE LEAD WIDTH DIMENSION AT MAXIMUM MATERIAL CONDITION. DAMBAR CANNOT BE LOCATED ON THE LOWER RADIUS OR THE FOOT. MINIMUM SPACE BETWEEN PROTRUSIONS AND ADJACENT LEAD TO BE 0.46 (0.018).

DIM	MILLIMETERS		INCHES	
	MIN	MAX	MIN	MAX
A	---	2.05	---	0.081
A <sub>1</sub>	0.05	0.20	0.002	0.008
b	0.35	0.50	0.014	0.020
c	0.10	0.20	0.007	0.011
D	9.90	10.50	0.390	0.413
E	5.10	5.45	0.201	0.215
e	1.27 BSC		0.050 BSC	
H <sub>E</sub>	7.40	8.20	0.291	0.323
L	0.50	0.85	0.020	0.033
L <sub>E</sub>	1.10	1.50	0.043	0.059
M	0°	10°	0°	10°
Q <sub>1</sub>	0.70	0.90	0.028	0.035
Z	---	0.78	---	0.031

ON Semiconductor and the  are registered trademarks of Semiconductor Components Industries, LLC (SCILLC) or its subsidiaries in the United States and/or other countries. SCILLC owns the rights to a number of patents, trademarks, copyrights, trade secrets, and other intellectual property. A listing of SCILLC's product/patent coverage may be accessed at [www.onsemi.com/site/pdf/Patent-Marking.pdf](http://www.onsemi.com/site/pdf/Patent-Marking.pdf). SCILLC reserves the right to make changes without further notice to any products herein. SCILLC makes no warranty, representation or guarantee regarding the suitability of its products for any particular purpose, nor does SCILLC assume any liability arising out of the application or use of any product or circuit, and specifically disclaims any and all liability, including without limitation special, consequential or incidental damages. "Typical" parameters which may be provided in SCILLC data sheets and/or specifications can and do vary in different applications and actual performance may vary over time. All operating parameters, including "Typicals" must be validated for each customer application by customer's technical experts. SCILLC does not convey any license under its patent rights nor the rights of others. SCILLC products are not designed, intended, or authorized for use as components in systems intended for surgical implant into the body, or other applications intended to support or sustain life, or for any other application in which the failure of the SCILLC product could create a situation where personal injury or death may occur. Should Buyer purchase or use SCILLC products for any such unintended or unauthorized application, Buyer shall indemnify and hold SCILLC and its officers, employees, subsidiaries, affiliates, and distributors harmless against all claims, costs, damages, and expenses, and reasonable attorney fees arising out of, directly or indirectly, any claim of personal injury or death associated with such unintended or unauthorized use, even if such claim alleges that SCILLC was negligent regarding the design or manufacture of the part. SCILLC is an Equal Opportunity/Affirmative Action Employer. This literature is subject to all applicable copyright laws and is not for resale in any manner.

### PUBLICATION ORDERING INFORMATION

#### LITERATURE FULFILLMENT:

Literature Distribution Center for ON Semiconductor  
P.O. Box 5163, Denver, Colorado 80217 USA  
Phone: 303-675-2175 or 800-344-3860 Toll Free USA/Canada  
Fax: 303-675-2176 or 800-344-3867 Toll Free USA/Canada  
Email: [orderlit@onsemi.com](mailto:orderlit@onsemi.com)

**N. American Technical Support:** 800-282-9855 Toll Free  
USA/Canada  
**Europe, Middle East and Africa Technical Support:**  
Phone: 421 33 790 2910  
**Japan Customer Focus Center**  
Phone: 81-3-5817-1050

**ON Semiconductor Website:** [www.onsemi.com](http://www.onsemi.com)

**Order Literature:** <http://www.onsemi.com/orderlit>

For additional information, please contact your local Sales Representative

## Looking for pricing, stock, or lifecycle information?

Click below to explore more details on WIN SOURCE:

 [View MC14511BDG on WIN SOURCE](#)

 [ON Semiconductor](#) Information

## Optimize Your Supply Chain with WIN SOURCE Solutions

-  Global Sourcing Solution
-  Obsolete Management
-  Cost Control Management
-  Shortage Management
-  Alternative Solution
-  Excess Inventory Management