

MC14020B

14-Bit Binary Counter

The MC14020B 14-stage binary counter is constructed with MOS P-Channel and N-Channel enhancement mode devices in a single monolithic structure. This part is designed with an input wave shaping circuit and 14 stages of ripple-carry binary counter. The device advances the count on the negative-going edge of the clock pulse. Applications include time delay circuits, counter controls, and frequency-dividing circuits.

Features

- Fully Static Operation
- Diode Protection on All Inputs
- Supply Voltage Range = 3.0 Vdc to 18 Vdc
- Capable of Driving Two Low-power TTL Loads or One Low-power Schottky TTL Load Over the Rated Temperature Range
- Buffered Outputs Available from stages 1 and 4 thru 14
- Common Reset Line
- Pin-for-Pin Replacement for CD4020B
- NLV Prefix for Automotive and Other Applications Requiring Unique Site and Control Change Requirements; AEC-Q100 Qualified and PPAP Capable
- These Devices are Pb-Free and are RoHS Compliant

MAXIMUM RATINGS (Voltages Referenced to V_{SS})

| Symbol | Parameter | Value | Unit |
|-------------------|---|------------------------|-------------|
| V_{DD} | DC Supply Voltage Range | -0.5 to +18.0 | V |
| V_{in}, V_{out} | Input or Output Voltage Range (DC or Transient) | -0.5 to $V_{DD} + 0.5$ | V |
| I_{in}, I_{out} | Input or Output Current (DC or Transient) per Pin | ± 10 | mA |
| P_D | Power Dissipation, per Package (Note 1) | 500 | mW |
| T_A | Ambient Temperature Range | -55 to +125 | $^{\circ}C$ |
| T_{stg} | Storage Temperature Range | -65 to +150 | $^{\circ}C$ |
| T_L | Lead Temperature (8-Second Soldering) | 260 | $^{\circ}C$ |

Stresses exceeding those listed in the Maximum Ratings table may damage the device. If any of these limits are exceeded, device functionality should not be assumed, damage may occur and reliability may be affected.

1. Temperature Derating: "D/DW" Packages: -7.0 mW/ $^{\circ}C$ From 65 $^{\circ}C$ To 125 $^{\circ}C$

This device contains protection circuitry to guard against damage due to high static voltages or electric fields. However, precautions must be taken to avoid applications of any voltage higher than maximum rated voltages to this high-impedance circuit. For proper operation, V_{in} and V_{out} should be constrained to the range $V_{SS} \leq (V_{in} \text{ or } V_{out}) \leq V_{DD}$.

Unused inputs must always be tied to an appropriate logic voltage level (e.g., either V_{SS} or V_{DD}). Unused outputs must be left open.



ON Semiconductor®

<http://onsemi.com>

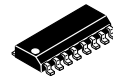

SOIC-16
D SUFFIX
CASE 751B



TSSOP-16
DT SUFFIX
CASE 948F

PIN ASSIGNMENT

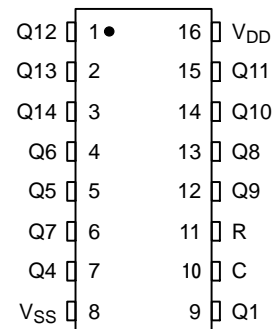

MARKING DIAGRAMS

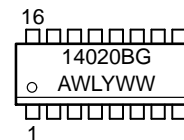

SOIC-16

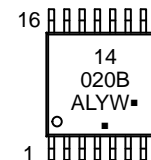

TSSOP-16

- A = Assembly Location
- WL, L = Wafer Lot
- YY, Y = Year
- WW, W = Work Week
- G or ■ = Pb-Free Indicator

(Note: Microdot may be in either location)

ORDERING INFORMATION

See detailed ordering and shipping information in the package dimensions section on page 2 of this data sheet.

MC14020B

ELECTRICAL CHARACTERISTICS (Voltages Referenced to V_{SS})

| Characteristic | Symbol | V _{DD} Vdc | -55°C | | 25°C | | | 125°C | | Unit | |
|---|-----------------|------------------------|---|-------|------|-----------------|-------|-------|-------|------|------|
| | | | Min | Max | Min | Typ (Note 2) | Max | Min | Max | | |
| Output Voltage V _{in} = V _{DD} or 0 | "0" Level | V _{OL} | 5.0 | - | 0.05 | - | 0 | 0.05 | - | 0.05 | Vdc |
| | | | 10 | - | 0.05 | - | 0 | 0.05 | - | 0.05 | |
| | | | 15 | - | 0.05 | - | 0 | 0.05 | - | 0.05 | |
| | "1" Level | V _{OH} | 5.0 | 4.95 | - | 4.95 | 5.0 | - | 4.95 | - | Vdc |
| | | | 10 | 9.95 | - | 9.95 | 10 | - | 9.95 | - | |
| | | | 15 | 14.95 | - | 14.95 | 15 | - | 14.95 | - | |
| Input Voltage (V _O = 4.5 or 0.5 Vdc) (V _O = 9.0 or 1.0 Vdc) (V _O = 13.5 or 1.5 Vdc) | "0" Level | V _{IL} | 5.0 | - | 1.5 | - | 2.25 | 1.5 | - | 1.5 | Vdc |
| | | | 10 | - | 3.0 | - | 4.50 | 3.0 | - | 3.0 | |
| | | | 15 | - | 4.0 | - | 6.75 | 4.0 | - | 4.0 | |
| | "1" Level | V _{IH} | 5.0 | 3.5 | - | 3.5 | 2.75 | - | 3.5 | - | Vdc |
| | | | 10 | 7.0 | - | 7.0 | 5.50 | - | 7.0 | - | |
| | | | 15 | 11 | - | 11 | 8.25 | - | 11 | - | |
| Output Drive Current (V _{OH} = 2.5 Vdc) (V _{OH} = 4.6 Vdc) (V _{OH} = 9.5 Vdc) (V _{OH} = 13.5 Vdc) | Source | I _{OH} | 5.0 | -3.0 | - | -2.4 | -4.2 | - | -1.7 | - | mAdc |
| | | | 5.0 | -0.64 | - | -0.51 | -0.88 | - | -0.36 | - | |
| | | | 10 | -1.6 | - | -1.3 | -2.25 | - | -0.9 | - | |
| | | | 15 | -4.2 | - | -3.4 | -8.8 | - | -2.4 | - | |
| | Sink | I _{OL} | 5.0 | 0.64 | - | 0.51 | 0.88 | - | 0.36 | - | mAdc |
| | | | 10 | 1.6 | - | 1.3 | 2.25 | - | 0.9 | - | |
| 15 | | | 4.2 | - | 3.4 | 8.8 | - | 2.4 | - | | |
| Input Current | I _{in} | 15 | - | ±0.1 | - | ±0.00001 | ±0.1 | - | ±1.0 | µAdc | |
| Input Capacitance (V _{in} = 0) | C _{in} | - | - | - | - | 5.0 | 7.5 | - | - | pF | |
| Quiescent Current (Per Package) | I _{DD} | 5.0 | - | 5.0 | - | 0.005 | 5.0 | - | 150 | µAdc | |
| | | 10 | - | 10 | - | 0.010 | 10 | - | 300 | | |
| | | 15 | - | 20 | - | 0.015 | 20 | - | 600 | | |
| Total Supply Current (Notes 3 & 4) (Dynamic plus Quiescent, Per Package) (C _L = 50 pF on all outputs, all buffers switching) | I _T | 5.0 | I _T = (0.42 µA/kHz)f + I _{DD} | | | | | | | µAdc | |
| | | 10 | I _T = (0.85 µA/kHz)f + I _{DD} | | | | | | | | |
| | | 15 | I _T = (1.43 µA/kHz)f + I _{DD} | | | | | | | | |

Product parametric performance is indicated in the Electrical Characteristics for the listed test conditions, unless otherwise noted. Product performance may not be indicated by the Electrical Characteristics if operated under different conditions.

- Data labelled "Typ" is not to be used for design purposes but is intended as an indication of the IC's potential performance.
- The formulas given are for the typical characteristics only at 25°C.
- To calculate total supply current at loads other than 50 pF:

$$I_T(C_L) = I_T(50 \text{ pF}) + (C_L - 50) Vfk$$

where: I_T is in µA (per package), C_L in pF, V = (V_{DD} - V_{SS}) in volts, f in kHz is input frequency, and k = 0.001.

MC14020B

SWITCHING CHARACTERISTICS (Note 5) ($C_L = 50 \text{ pF}$, $T_A = 25^\circ\text{C}$)

| Characteristic | Symbol | V_{DD} Vdc | Min | Typ (Note 6) | Max | Unit |
|--|--------------------------|-----------------|--------------------|--------------------|----------------------|------|
| Output Rise and Fall Time t_{TLH} , $t_{THL} = (1.5 \text{ ns/pF}) C_L + 25 \text{ ns}$ t_{TLH} , $t_{THL} = (0.75 \text{ ns/pF}) C_L + 12.5 \text{ ns}$ t_{TLH} , $t_{THL} = (0.55 \text{ ns/pF}) C_L + 9.5 \text{ ns}$ | t_{TLH} , t_{THL} | 5.0 10 15 | – – – | 100 50 40 | 200 100 80 | ns |
| Propagation Delay Time Clock to Q1 t_{PHL} , $t_{PLH} = (1.7 \text{ ns/pF}) C_L + 175 \text{ ns}$ t_{PHL} , $t_{PLH} = (0.66 \text{ ns/pF}) C_L + 82 \text{ ns}$ t_{PHL} , $t_{PLH} = (0.5 \text{ ns/pF}) C_L + 55 \text{ ns}$ | t_{PLH} , t_{PHL} | 5.0 10 15 | – – – | 260 115 80 | 520 230 160 | ns |
| Clock to Q14 t_{PHL} , $t_{PLH} = (1.7 \text{ ns/pF}) C_L + 1735 \text{ ns}$ t_{PHL} , $t_{PLH} = (0.66 \text{ ns/pF}) C_L + 772 \text{ ns}$ t_{PHL} , $t_{PLH} = (0.5 \text{ ns/pF}) C_L + 535 \text{ ns}$ | | 5.0 10 15 | – – – | 1820 805 560 | 3900 1725 1200 | ns |
| Propagation Delay Time Reset to Q_n $t_{PHL} = (1.7 \text{ ns/pF}) C_L + 285 \text{ ns}$ $t_{PHL} = (0.66 \text{ ns/pF}) C_L + 122 \text{ ns}$ $t_{PHL} = (0.5 \text{ ns/pF}) C_L + 90 \text{ ns}$ | t_{PHL} | 5.0 10 15 | – – – | 370 155 115 | 740 310 230 | ns |
| Clock Pulse Width | t_{WH} | 5.0 10 15 | 500 165 125 | 140 55 38 | – – – | ns |
| Clock Pulse Frequency | f_{max} | 5.0 10 15 | 1.0 3.0 4.0 | 2.0 6.0 8.0 | – – – | MHz |
| Clock Rise and Fall Time | t_{TLH} , t_{THL} | 5.0 10 15 | No Limit | | | – |
| Reset Pulse Width | t_{WL} | 5.0 10 15 | 3000 550 420 | 320 120 80 | – – – | ns |
| Reset Recovery Time | t_{rec} | 5.0 10 15 | – – – | 65 25 15 | 130 50 30 | ns |

5. The formulas given are for the typical characteristics only at 25°C.

6. Data labelled "Typ" is not to be used for design purposes but is intended as an indication of the IC's potential performance.

MC14020B

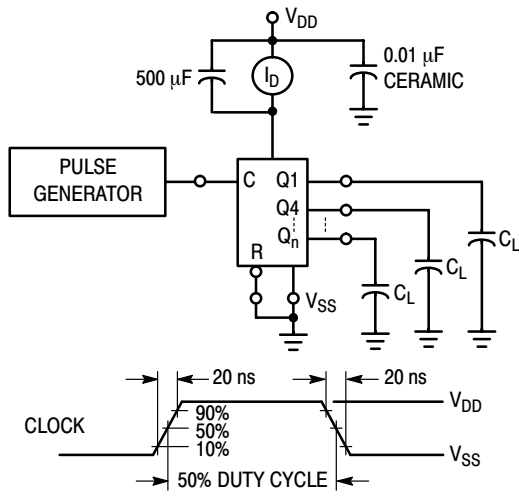

Figure 1. Power Dissipation Test Circuit and Waveform

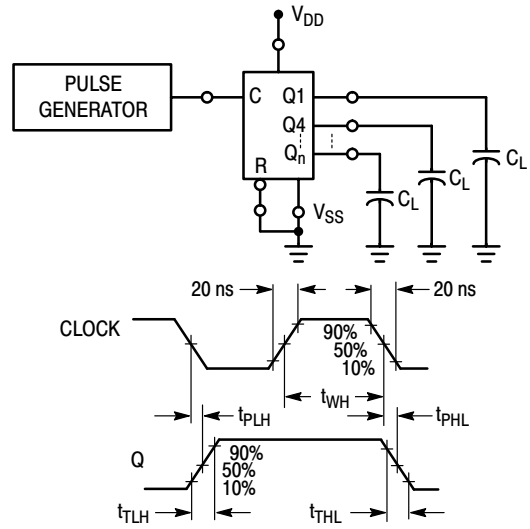

Figure 2. Switching Time Test Circuit and Waveforms

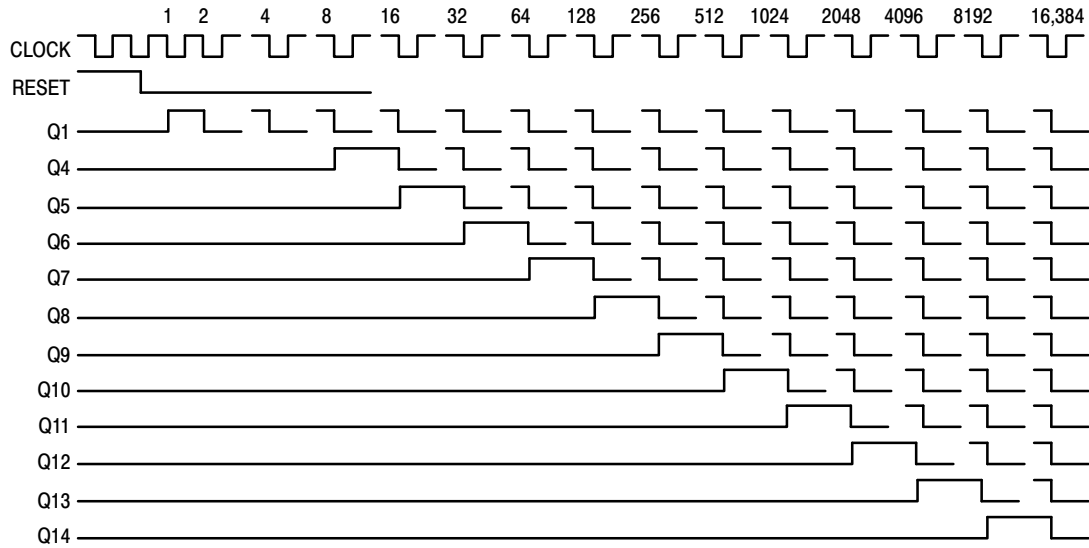
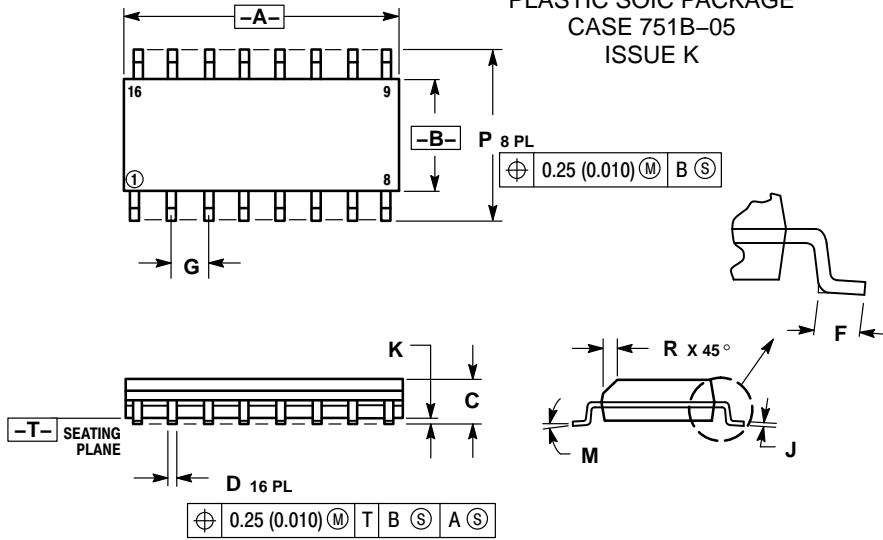

Figure 3. Timing Diagram

MC14020B

PACKAGE DIMENSIONS

SOIC-16 D SUFFIX PLASTIC SOIC PACKAGE CASE 751B-05 ISSUE K



- NOTES:
1. DIMENSIONING AND TOLERANCING PER ANSI Y14.5M, 1982.
 2. CONTROLLING DIMENSION: MILLIMETER.
 3. DIMENSIONS A AND B DO NOT INCLUDE MOLD PROTRUSION.
 4. MAXIMUM MOLD PROTRUSION 0.15 (0.006) PER SIDE.
 5. DIMENSION D DOES NOT INCLUDE DAMBAR PROTRUSION. ALLOWABLE DAMBAR PROTRUSION SHALL BE 0.127 (0.005) TOTAL IN EXCESS OF THE D DIMENSION AT MAXIMUM MATERIAL CONDITION.

| DIM | MILLIMETERS | | INCHES | |
|-----|-------------|-------|-----------|-------|
| | MIN | MAX | MIN | MAX |
| A | 9.80 | 10.00 | 0.386 | 0.393 |
| B | 3.80 | 4.00 | 0.150 | 0.157 |
| C | 1.35 | 1.75 | 0.054 | 0.068 |
| D | 0.35 | 0.49 | 0.014 | 0.019 |
| F | 0.40 | 1.25 | 0.016 | 0.049 |
| G | 1.27 BSC | | 0.050 BSC | |
| J | 0.19 | 0.25 | 0.008 | 0.009 |
| K | 0.10 | 0.25 | 0.004 | 0.009 |
| M | 0° | 7° | 0° | 7° |
| P | 5.80 | 6.20 | 0.229 | 0.244 |
| R | 0.25 | 0.50 | 0.010 | 0.019 |

SOLDERING FOOTPRINT*

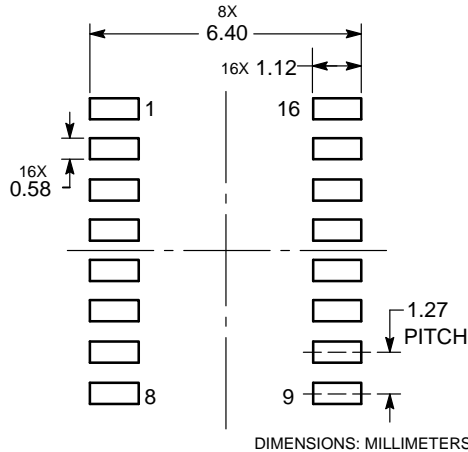

*For additional information on our Pb-Free strategy and soldering details, please download the ON Semiconductor Soldering and Mounting Techniques Reference Manual, SOLDERRM/D.

ON Semiconductor and the are registered trademarks of Semiconductor Components Industries, LLC (SCILLC) or its subsidiaries in the United States and/or other countries. SCILLC owns the rights to a number of patents, trademarks, copyrights, trade secrets, and other intellectual property. A listing of SCILLC's product/patent coverage may be accessed at www.onsemi.com/site/pdf/Patent-Marking.pdf. SCILLC reserves the right to make changes without further notice to any products herein. SCILLC makes no warranty, representation or guarantee regarding the suitability of its products for any particular purpose, nor does SCILLC assume any liability arising out of the application or use of any product or circuit, and specifically disclaims any and all liability, including without limitation special, consequential or incidental damages. "Typical" parameters which may be provided in SCILLC data sheets and/or specifications can and do vary in different applications and actual performance may vary over time. All operating parameters, including "Typicals" must be validated for each customer application by customer's technical experts. SCILLC does not convey any license under its patent rights nor the rights of others. SCILLC products are not designed, intended, or authorized for use as components in systems intended for surgical implant into the body, or other applications intended to support or sustain life, or for any other application in which the failure of the SCILLC product could create a situation where personal injury or death may occur. Should Buyer purchase or use SCILLC products for any such unintended or unauthorized application, Buyer shall indemnify and hold SCILLC and its officers, employees, subsidiaries, affiliates, and distributors harmless against all claims, costs, damages, and expenses, and reasonable attorney fees arising out of, directly or indirectly, any claim of personal injury or death associated with such unintended or unauthorized use, even if such claim alleges that SCILLC was negligent regarding the design or manufacture of the part. SCILLC is an Equal Opportunity/Affirmative Action Employer. This literature is subject to all applicable copyright laws and is not for resale in any manner.

PUBLICATION ORDERING INFORMATION

LITERATURE FULFILLMENT:
Literature Distribution Center for ON Semiconductor
P.O. Box 5163, Denver, Colorado 80217 USA
Phone: 303-675-2175 or 800-344-3860 Toll Free USA/Canada
Fax: 303-675-2176 or 800-344-3867 Toll Free USA/Canada
Email: orderlit@onsemi.com

N. American Technical Support: 800-282-9855 Toll Free
USA/Canada
Europe, Middle East and Africa Technical Support:
Phone: 421 33 790 2910
Japan Customer Focus Center
Phone: 81-3-5817-1050

ON Semiconductor Website: www.onsemi.com
Order Literature: <http://www.onsemi.com/orderlit>
For additional information, please contact your local Sales Representative

Looking for pricing, stock, or lifecycle information?

Click below to explore more details on WIN SOURCE:

 [View MC14020BDR2G on WIN SOURCE](#)

 [ON Semiconductor](#) Information

Optimize Your Supply Chain with WIN SOURCE Solutions

-  Global Sourcing Solution
-  Obsolete Management
-  Cost Control Management
-  Shortage Management
-  Alternative Solution
-  Excess Inventory Management