



**THE DATASHEET OF
MC13820FCR2**



MC13820



Package Information
 Plastic Package
 Case 1345
 (QFN-12)

MC13820

Low Noise Amplifier with Bypass Switch

Ordering Information

Device	Device Marking or Operating Temperature Range	Package
MC13820	820	QFN-12

1 Introduction

The MC13820 is a high gain LNA with extremely low noise figure, designed for cellular, GPS and ISM band applications. An integrated bypass switch is included to preserve input intercept performance. The input and output match are external to allow maximum design flexibility. The MC13820 is fabricated using Freescale's advanced RF BiCMOS process using the SiGe:C option and is packaged in the QFN12 leadless package.

Contents:

1 Introduction	1
2 Electrical Specifications	3
3 Application Information	10
4 Printed Circuit Board	23
5 Scattering Parameters	26
6 Packaging	35
7 Product Documentation	36

1.1 Features

- RF Input Frequency: 1000 MHz to 2.4 GHz
- Gain: 18 dB (typ) at 1575 MHz and 15.7 dB (typ) at 2140 MHz
- Output 3rd Order Intercept Point (OIP3): 18.5 dBm (typ) at 1575 MHz and 19.7 dBm (typ) at 2140 MHz
- Noise Figure (NF): 1.25 dB (typ) at 1575 MHz and 1.3 dB (typ) at 2140 MHz
- 1dB Compression Point (P1dB): -10 dBm (typ) at 1575 MHz and -5 dBm (typ) at 2140 MHz

Freescale reserves the right to change the detail specifications as may be required to permit improvements in the design of its products.

© Freescale Semiconductor, Inc., 2005. All rights reserved.

- Freescale’s IP3 Boost Circuitry
- Bypass Mode Included for Improved Intercept Point Performance
- Total Supply Current:
2.8 mA @ 2.7 Vdc
10 μ A (typ) in Bypass Mode
- Bias Stabilized for Device and Temperature Variations
- QFN-12 Leadless Package with Low Parasitics
- SiGe Technology Ensures Lowest Possible Noise Figure

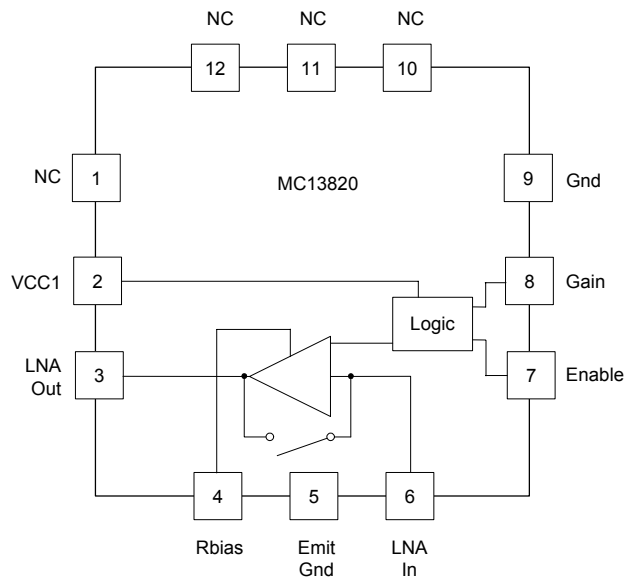

Figure 1. Simplified Block Diagram

2 Electrical Specifications

Table 1. Maximum Ratings

Ratings	Symbol	Value	Unit
Supply Voltage	V_{CC}	3.3	V
Storage Temperature Range	T_{stg}	-65 to 150	°C
Operating Ambient Temperature Range	T_A	-30 to 85	°C
RF Input Power	P_{rf}	10	dBm
Power Dissipation	P_{dis}	100	mW
Thermal Resistance, Junction to Case	$R_{\theta JC}$	24	C/W
Thermal Resistance, Junction to Ambient, 4 layer board	$R_{\theta JA}$	90	C/W

- NOTES:** 1. Maximum Ratings are those values beyond which damage to the device may occur. Functional operation should be restricted to the limits in the Recommended Operating Conditions and Electrical Characteristics tables.
2. ESD (electrostatic discharge) immunity meets Human Body Model (HBM) ≤ 200 V, Charge Device Model (CDM) ≤ 450 V, and Machine Model (MM) ≤ 50 V. Additional ESD data available upon request.

Table 2. Recommended Operating Conditions

Characteristic	Symbol	Min	Typ	Max	Unit
RF Frequency range	f_{RF}	1000		2400	MHz
Supply Voltage	V_{CC}	2.7	2.75	3	V
Logic Voltage					V
Input High Voltage		1.25	-	V_{CC}	
Input Low Voltage		0	-	0.8	

Table 3. Electrical Characteristics

 ($V_{CC} = 2.75$ V, $T_A = 25^\circ\text{C}$, unless otherwise noted.)

Characteristic	Symbol	Min	Typ	Max	Unit
Insertion Gain R1=1.2 k Ω , Freq=1.575 GHz R1=1.2 k Ω , Freq=2.14 GHz R1=2 k Ω , Freq=1.575 GHz R1=2 k Ω , Freq=2.14 GHz	$ S_{21} ^2$	16 14.5 14.3 13	17.1 15.6 15.3 14.2	- - - -	dB
Maximum Stable Gain and/or Maximum Available Gain ¹ R1=1.2 k Ω , Freq=1.575 GHz R1=1.2 k Ω , Freq=2.14 GHz R1=2 k Ω , Freq=1.575 GHz R1=2 k Ω , Freq=2.14 GHz	MSG, MAG	21.5 19.5 20.5 19.5	22.5 20.5 21.5 19.6	- - - -	dB
Minimum Noise Figure R1=1.2 k Ω , Freq=1.575 GHz R1=1.2 k Ω , Freq=2.14 GHz R1=2 k Ω , Freq=1.575 GHz R1=2 k Ω , Freq=2.14 GHz	NFmin	- - - -	1.01 0.96 1.01 0.96	1.1 1.05 1.1 1.05	dB

Table 3. Electrical Characteristics (continued)

($V_{CC} = 2.75\text{ V}$, $T_A = 25^\circ\text{C}$, unless otherwise noted.)

Characteristic	Symbol	Min	Typ	Max	Unit
Associated Gain at Minimum Noise Figure R1=1.2 k Ω , Freq=1.575 GHz R1=1.2 k Ω , Freq=2.14 GHz R1=2 k Ω , Freq=1.575 GHz R1=2 k Ω , Freq=2.14 GHz	Gnf	21.7 19 21.7 19	22.7 19.8 22.7 19.8	- - - -	dB

¹ Maximum Available Gain and Maximum Stable Gain are defined by the K factor as follows:

$$MAG = \left| \frac{S_{21}}{S_{12}} \left(K \pm \sqrt{K^2 - 1} \right) \right|, \text{ if } K > 1, \text{ MSG} = \left| \frac{S_{21}}{S_{12}} \right|, \text{ if } K < 1$$

Table 4. Electrical Characteristics Measured in Frequency Specific Tuned Circuits

($V_{CC} = 2.75\text{ V}$, $T_A = 25^\circ\text{C}$, $R_{bias} = 2\text{ k}\Omega$, unless otherwise noted.)

Characteristic	Symbol	Min	Typ	Max	Unit
1575 MHz (Refer to Figure 9)					
Frequency	f	-	1575	-	MHz
Active Gain	G	17.5	18	-	dB
Active Noise Figure	NF	-	1.25	1.4	dB
Active Input Third Order Intercept Point	IIP3	-1.0	0.5	-	dBm
Active Input 1dB Compression Point	P _{1dB}	-11	-10	-	dBm
Active Current @ 2.75 V	I _{CC}	-	2.8	3.3	mA
Bypass Gain	G	-6.0	-5.0	-	dB
Bypass Noise Figure	NF	-	4.8	5.2	dB
Bypass Input Third Order Intercept Point	IIP3	26	27	-	dBm
Bypass Current		-	10	20	μA
1960 MHz (Refer to Figure 10)					
Frequency	f	-	1960	-	MHz
Active Gain	G	16	16.4	-	dB
Active Noise Figure	NF	-	1.25	1.4	dB
Active Input Third Order Intercept Point	IIP3	0	1	-	dBm
Active Input 1dB Compression Point	P _{1dB}	-7.0	-6	-	dBm
Active Current @ 2.75 V	I _{CC}	-	2.8	3.3	mA
Bypass Gain	G	-5.0	-4	-	dB
Bypass Noise Figure	NF	-	4.7	5.1	dB
Bypass Input Third Order Intercept Point	IIP3	23	25	-	dBm
Bypass Current		-	10	20	μA

Table 4. Electrical Characteristics Measured in Frequency Specific Tuned Circuits (continued)

 ($V_{CC} = 2.75$ V, $T_A = 25^\circ\text{C}$, $R_{bias} = 2$ k Ω , unless otherwise noted.)

Characteristic	Symbol	Min	Typ	Max	Unit
2140 MHz (Refer to Figure 11)					
Frequency	f	-	2140	-	MHz
Active Gain	G	15.3	15.7	-	dB
Active Noise Figure	NF	-	1.3	1.4	dB
Active Input Third Order Intercept Point	IIP3	2.5	3.5	-	dBm
Active Input 1dB Compression Point	P_{1dB}	-6.0	-5	-	dBm
Active Current @ 2.75 V	I_{CC}	-	2.8	3.2	mA
Bypass Gain	G	-4.2	-3.2	-	dB
Bypass Noise Figure	NF	-	3.2	3.6	dB
Bypass Input Third Order Intercept Point	IIP3	22.5	24.5	-	dBm
Bypass Current		-	10	20	μA
2400 MHz (Refer to Figure 12)					
Frequency	f	-	2400	-	MHz
Active Gain	G	13.8	14	-	dB
Active Noise Figure	NF	-	1.49	1.6	dB
Active Input Third Order Intercept Point	IIP3	3.5	4.0	-	dBm
Active Input 1dB Compression Point	P_{1dB}	-5.0	-4.0	-	dBm
Active Current @ 2.75 V	I_{CC}	-	2.8	3.2	mA
Bypass Gain	G	-5.0	-4.0	-	dB
Bypass Noise Figure	NF	-	4.2	4.7	dB
Bypass Input Third Order Intercept Point	IIP3	22	24	-	dBm
Bypass Current		-	10	20	μA

Table 5. Truth Table

Pin Function	Pin Name	Enable		Disable	
		Low Gain	High Gain	Low Gain	High Gain
Circuit Bias VCC1	VCC1	1	1	1	1
Toggles Gain Mode (Active or Bypass)	GAIN	0	1	0	1
Toggles LNA On/Off	ENABLE	1	1	0	0
LNA Bias VCC3	LNA Out	1	1	1	1

NOTES: 1. Logic state "1" equals V_{CC} voltage. Logic state of "0" equals ground potential.
 2. VCC3 is inductively coupled to LNA OUT pin
 3. Minimum logic state "1" for enable and gain pins is 1.25 V.
 4. Maximum logic state "0" for enable and gain pins is 0.8 V.

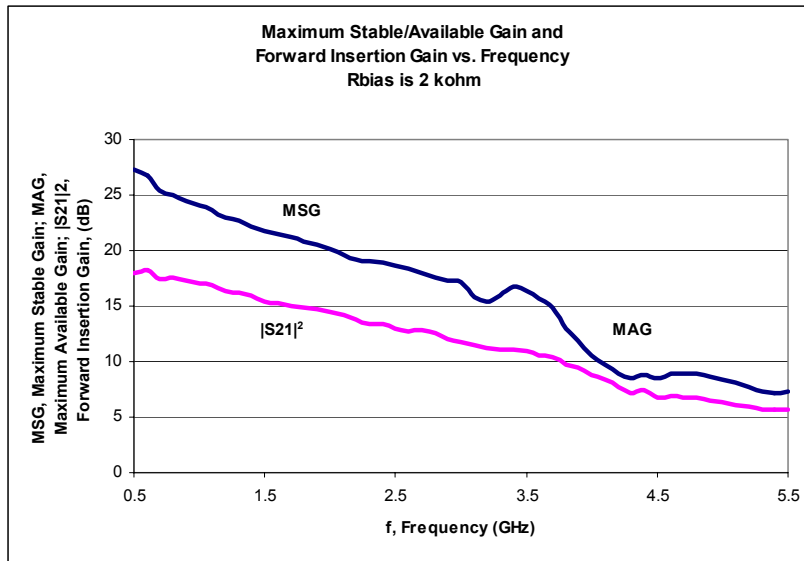

Figure 2. Maximum Stable/Available Gain and Forward Insertion Gain vs. Frequency (Rbias = 2 kΩ)

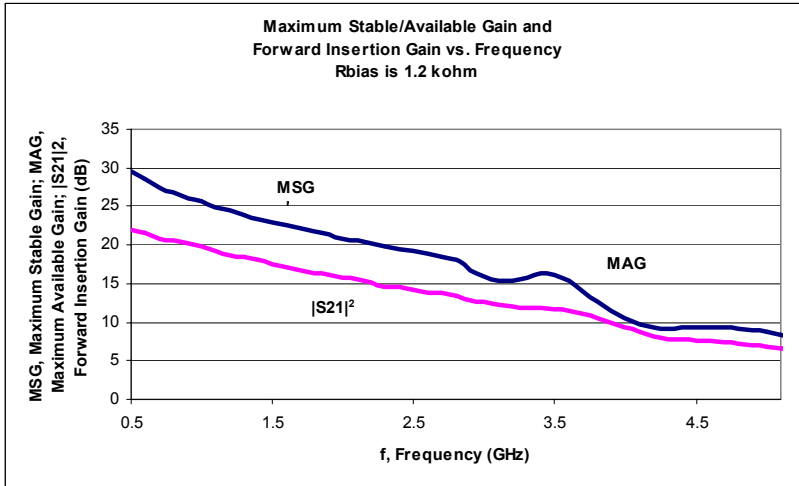

Figure 3. Maximum Stable/Available Gain and Forward Insertion Gain vs. Frequency
(Rbias = 1.2 kΩ)

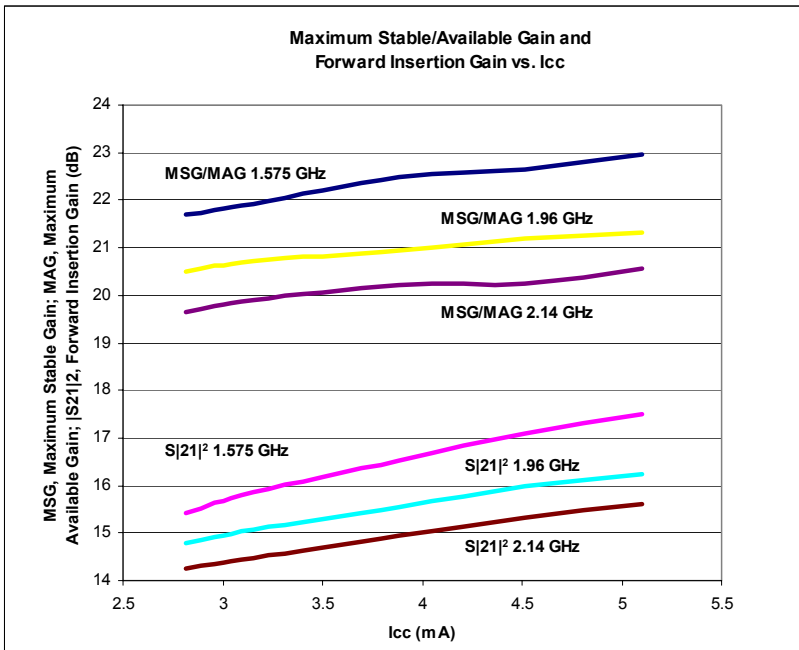

Figure 4. Maximum Stable/Available Gain and Forward Insertion Gain vs. Icc

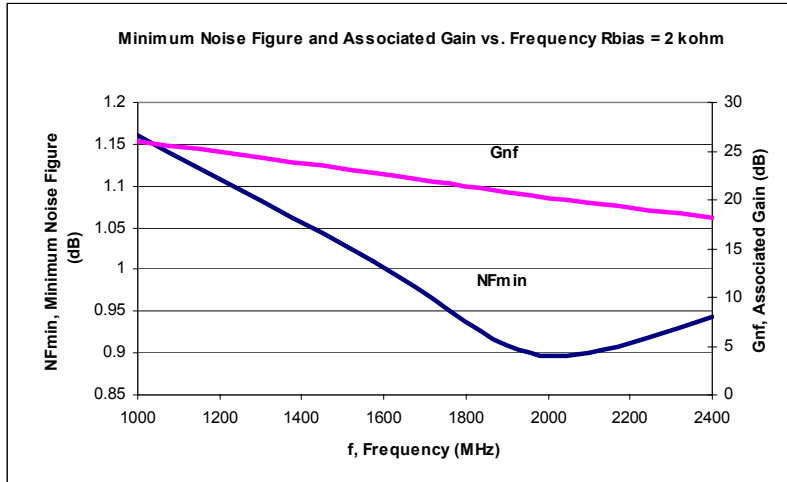

Figure 5. Minimum Noise Figure and Associated Gain vs. Frequency (Rbias = 2 kΩ)

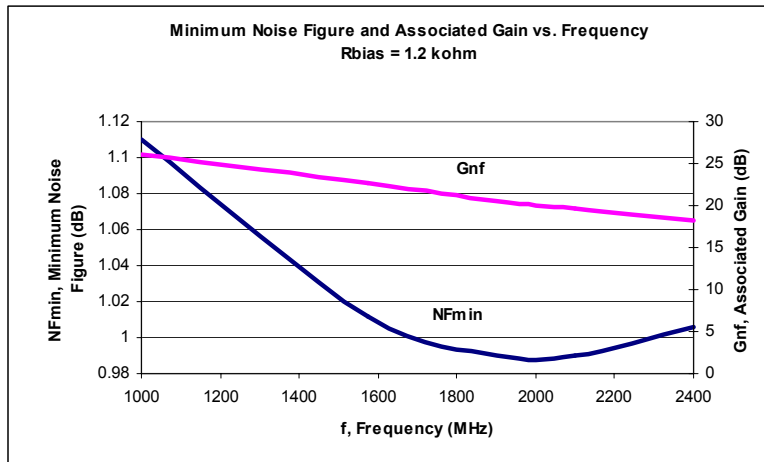

Figure 6. Minimum Noise Figure and Associated Gain vs. Frequency (Rbias = 1.2 kΩ)

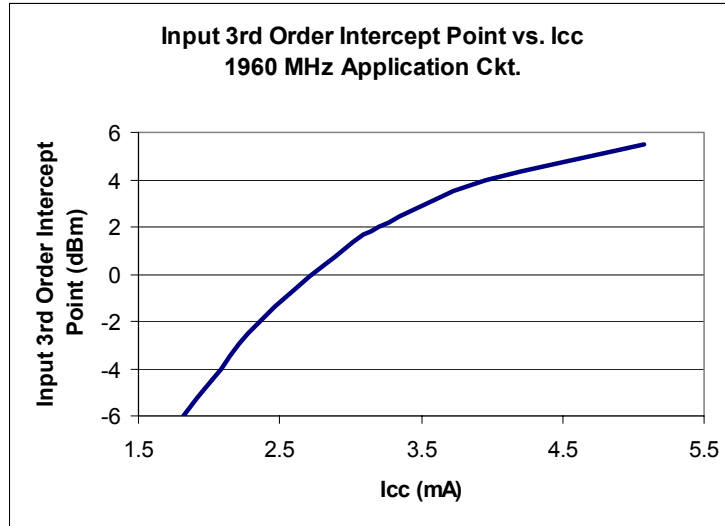

Figure 7. Input 3rd Order Intercept Point vs. Icc for the 1960 MHz Application Circuit
(Rbias varied from 1.2 k Ω to 3 k Ω)

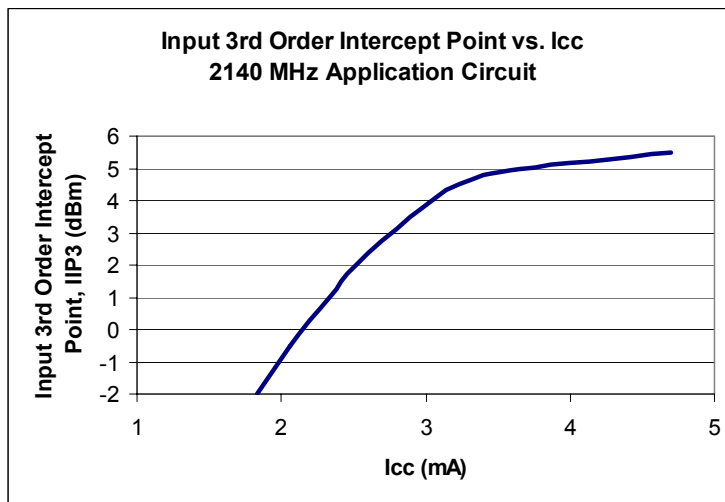

Figure 8. Input 3rd Order Intercept Point vs. Icc for the 2140 MHz Application Circuit
(Rbias varied from 1.2 k Ω to 3 k Ω)

3 Application Information

The MC13820 SiGe:C LNA is designed for applications in the 1000 MHz to 2.4 GHz range. It has three different modes: High Gain, Low Gain (Bypass) and Disabled. The IC is programmable through the Gain and Enable pins. The logic truth table is given in [Table 5](#).

In these application examples a balance is made between the competing RF performance characteristics of I_{CC} , NF, gain, IP3 and return losses with unconditional stability. Conjugate matching is not used for the input or output. Instead, matching which achieves a trade-off in RF performance qualities is utilized. For a particular application or spec requirement, the matching can be changed to achieve enhanced performance of one parameter at the expense of other parameters.

Application information for 1575, 1960, 2140 and 2400 MHz are shown. For each application, two current drain examples are provided. Typical RF performance is shown for two values of bias resistor R1: 1.2 k Ω and 2 k Ω , see [Table 6](#), [Table 7](#), [Table 8](#), and [Table 9](#). These two current drain states offer variation in intercept point, gain, and noise figure. Measurements are made at a bias of $V_{CC} = 2.75$ V. Freq. spacing for IP3 measurements is 200 kHz. Non-linear measurements are made at $P_{in} = -30$ dB. The board loss corrections for these boards are: Input 0.16 dB, Output 0.2 dB. Gain and NF results incorporate these corrections in order to better reflect the actual performance of the device.

3.1 1575 MHz Application

This application circuit was designed to provide NF < 1.2 dB, S21 gain > 18 dB, OIP3 of 18 dBm with S11 better than -10 dB and S22 better than -10 dB at 1575 MHz with unconditional stability from 100 MHz to 10 GHz. Typical performance that can be expected from this circuit at 2.75 V V_{CC} is listed in [Table 6](#). The component values can be changed to enhance the performance of a particular parameter, but usually at the expense of another. Two variations of the circuit are realized for different requirements for IP3 and I_{CC} . Values of external resistors R1 and R2 are varied to adjust I_{CC} and IP3.

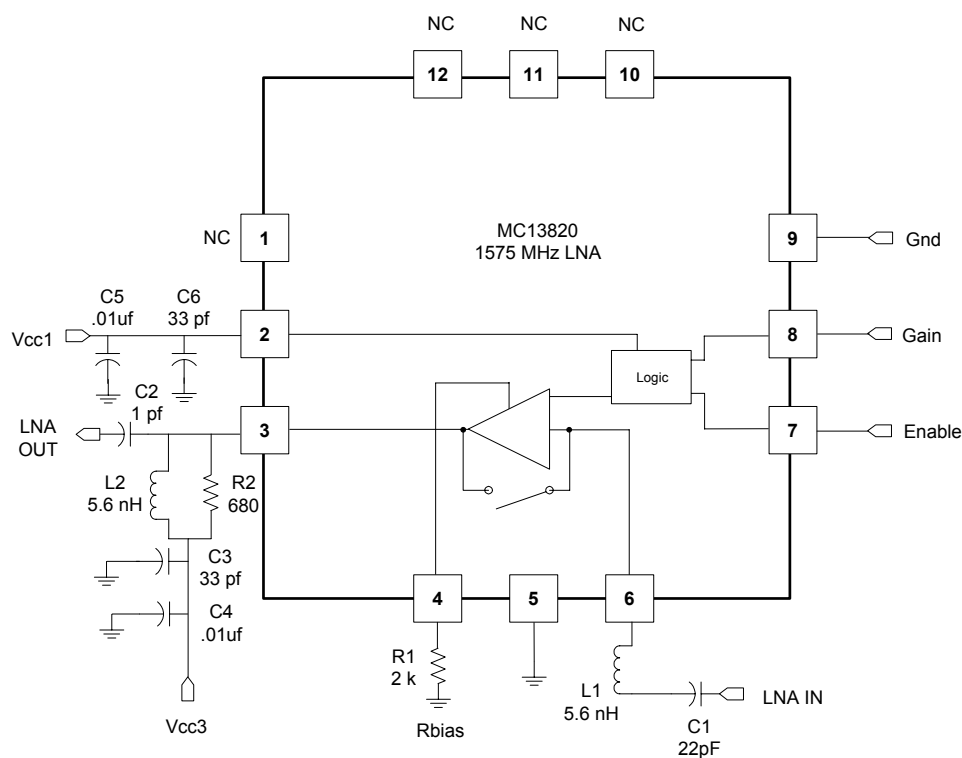
Figure 9. 1575 MHz LNA Application Schematic
Table 6. Typical 1575 MHz LNA Demo Board Performance

 (Resistor values of R1 and R2 are changed for different I_{CC} and IP3 requirements.)

Characteristic	Symbol	Min	Typ	Max	Unit
R1 = 1.2 kΩ, R2 = 620 Ω					
Frequency	f	-	1575.42	-	MHz
Power Gain	G	-	18	-	dB
High Gain		-	18	-	
Bypass		-	-4.7	-	
Output Third Order Intercept Point	OIP3	-	20	-	dBm
High Gain		-	20	-	
Bypass		-	20.8	-	
Input Third Order Intercept Point	IIP3	-	2.0	-	dBm
High Gain		-	2.0	-	
Bypass		-	25.5	-	
Out Ref P1dB	P _{1dBout}	-	10	-	dBm
High Gain		-	10	-	
Bypass		-	-	-	
In Ref P1dB	P _{1dBin}	-	-8.0	-	dBm
High Gain		-	-8.0	-	
Bypass		-	-	-	

Table 6. Typical 1575 MHz LNA Demo Board Performance (continued)
 (Resistor values of R1 and R2 are changed for different I_{CC} and IP3 requirements.)

Characteristic	Symbol	Min	Typ	Max	Unit
Insertion Gain High Gain Bypass	G	- -	18.5 -3.4	- -	dBm
Noise Figure High Gain Bypass	NF	- -	1.25 4.8	- -	dB
Current Drain High Gain Bypass	I_{CC}	- -	4.45 4.0	- -	mA μ A
Rbias R1 Value		-	1.2	-	k Ω
Rstability R2 Value		-	620	-	Ω
Input Return Loss High Gain Bypass	S11	- -	-15.5 -8.1	- -	dB
Gain High Gain Bypass	S21	- -	18.2 -4.1	- -	dB
Reverse Isolation High Gain Bypass	S12	- -	-23.7 -4.4	- -	dB
Output Return Loss High Gain Bypass	S22	- -	-13.9 -6.8	- -	dB
R1 = 2.0 kΩ, R2 = 680 Ω					
Frequency	f	-	1575.42	-	MHz
Power Gain High Gain Bypass	G	- -	18 -5.0	- -	dB
Output Third Order Intercept Point High Gain Bypass	OIP3	- -	18.7 21.7	- -	dBm
Input Third Order Intercept Point High Gain Bypass	IIP3	- -	0.5 27	- -	dBm
Out Ref P1dB High Gain Bypass	P_{1dBout}	- -	8.2 -	- -	dBm
In Ref P1dB High Gain Bypass	P_{1dBin}	- -	-10 -	- -	dBm

Table 6. Typical 1575 MHz LNA Demo Board Performance (continued)
 (Resistor values of R1 and R2 are changed for different I_{CC} and IP3 requirements.)

Characteristic	Symbol	Min	Typ	Max	Unit
Insertion Gain High Gain Bypass	G	- -	18.1 -3.6	- -	dBm
Noise Figure High Gain Bypass	NF	- -	1.25 4.8	- -	dB
Current Drain High Gain Bypass	I_{CC}	- -	2.8 4.0	- -	mA μ A
Rbias R1 Value		-	2.0	-	k Ω
Rstability R2 Value		-	680	-	Ω
Input Return Loss High Gain Bypass	S11	- -	-13.5 -9.0	- -	dB
Gain High Gain Bypass	S21	- -	17.9 -4.1	- -	dB
Reverse Isolation High Gain Bypass	S12	- -	-22.9 -4.3	- -	dB
Output Return Loss High Gain Bypass	S22	- -	-10.8 -7.2	- -	dB

3.2 1960 MHz Application

This application circuit was designed to provide $NF < 1.3$ dB, S_{21} gain > 16 dB, $OIP3$ of 17 dBm with S_{11} better than -10 dB and S_{22} better than -10 dB at 1960 MHz with unconditional stability from 100 MHz to 10 GHz. Typical performance that can be expected from this circuit at 2.75 V V_{CC} is listed in Table 7. The component values can be changed to enhance the performance of a particular parameter, but usually at the expense of another. Two variations of the circuit are realized for different requirements for $IP3$ and I_{CC} . Values of external resistors $R1$ and $R2$ are varied to adjust I_{CC} and $IP3$.

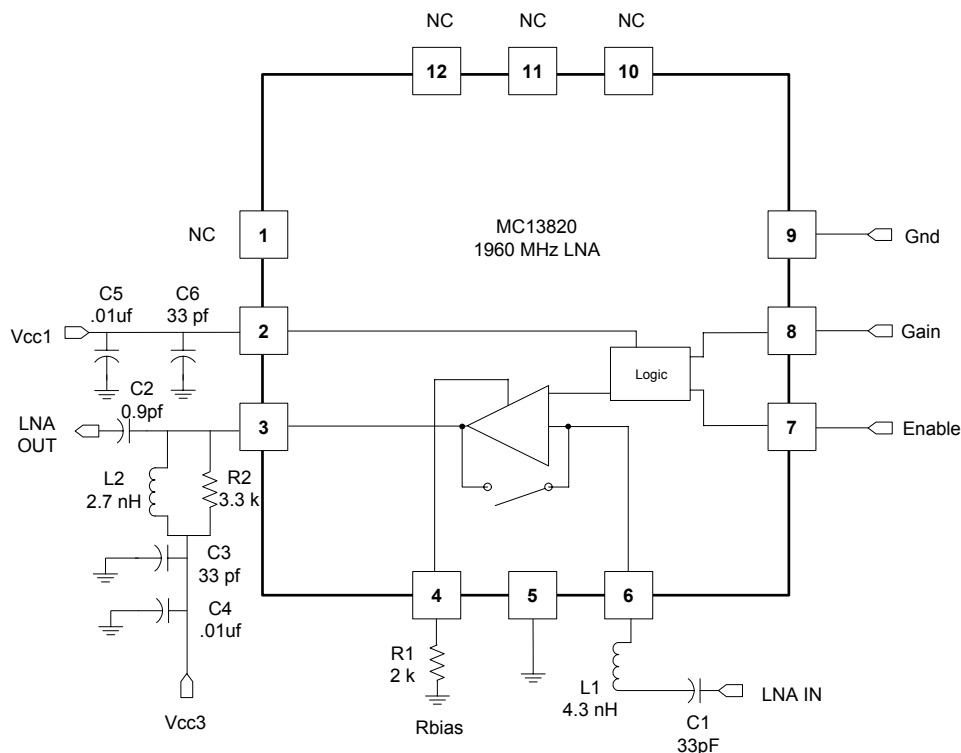

Figure 10. 1960 MHz LNA Application Schematic

Table 7. Typical 1960 MHz LNA Demo Board Performance
(Resistor values of $R1$ and $R2$ are changed for different I_{CC} and $IP3$ requirements.)

Characteristic	Symbol	Min	Typ	Max	Unit
$R1 = 1.2$ kΩ, $R2 = 3.3$ kΩ					
Frequency	f	-	1960	-	MHz
Power Gain	G	-	16	-	dB
High Gain		-	-4.5	-	
Bypass		-		-	
Output Third Order Intercept Point	OIP3	-	22	-	dBm
High Gain		-	20.5	-	
Bypass		-		-	
Input Third Order Intercept Point	IIP3	-	5.5	-	dBm
High Gain		-	25	-	
Bypass		-		-	

Table 7. Typical 1960 MHz LNA Demo Board Performance (continued)

 (Resistor values of R1 and R2 are changed for different I_{CC} and IP3 requirements.)

Characteristic	Symbol	Min	Typ	Max	Unit
Out Ref P1dB High Gain Bypass	P_{1dBout}	- -	10.5 -	- -	dBm
In Ref P1dB High Gain Bypass	P_{1dBin}	- -	-6.0 -	- -	dBm
Insertion Gain High Gain Bypass	G	- -	16.8 -3.7	- -	dBm
Noise Figure High Gain Bypass	NF	- -	1.26 2.5	- -	dB
Current Drain High Gain Bypass	I_{CC}	- -	4.45 10	- -	mA μ A
Rbias R1 Value		-	1.2	-	k Ω
Rstability R2 Value		-	3.3	-	k Ω
Input Return Loss High Gain Bypass	S11	- -	-9.7 -8.7	- -	dB
Gain High Gain Bypass	S21	- -	16.6 -3.8	- -	dB
Reverse Isolation High Gain Bypass	S12	- -	-21.7 -4.2	- -	dB
Output Return Loss High Gain Bypass	S22	- -	-14.6 -6.3	- -	dB
R1 = 2.0 kΩ, R2 = 3.3 kΩ					
Frequency	f	-	1960	-	MHz
Power Gain High Gain Bypass	G	- -	16.4 -4.0	- -	dB
Output Third Order Intercept Point High Gain Bypass	OIP3	- -	17.4 21	- -	dBm
Input Third Order Intercept Point High Gain Bypass	IIP3	- -	1.0 25	- -	dBm

Table 7. Typical 1960 MHz LNA Demo Board Performance (continued)
 (Resistor values of R1 and R2 are changed for different I_{CC} and IP3 requirements.)

Characteristic	Symbol	Min	Typ	Max	Unit
Out Ref P1dB High Gain Bypass	P_{1dBout}	- -	10.4 -	- -	dBm
In Ref P1dB High Gain Bypass	P_{1dBin}	- -	-6.0 -	- -	dBm
Insertion Gain High Gain Bypass	G	- -	16.5 -3.7	- -	dBm
Noise Figure High Gain Bypass	NF	- -	1.25 4.7	- -	dB
Current Drain High Gain Bypass	I_{CC}	- -	2.8 4.0	- -	mA μ A
Rbias R1 Value		-	2.0	-	k Ω
Rstability R2 Value		-	3.3	-	k Ω
Input Return Loss High Gain Bypass	S11	- -	-9.2 -9.8	- -	dB
Gain High Gain Bypass	S21	- -	16.6 -3.9	- -	dB
Reverse Isolation High Gain Bypass	S12	- -	-21.1 -4.0	- -	dB
Output Return Loss High Gain Bypass	S22	- -	-25 -7.8	- -	dB

3.3 2140 MHz Application

This application circuit was designed to provide $NF < 1.3$ dB, S_{21} gain > 16 dB, $OIP3$ of 18 dBm with S_{11} better than -10 dB and S_{22} better than -10 dB at 2140 MHz with unconditional stability from 100 MHz to 10 GHz. Typical performance that can be expected from this circuit at 2.75 V V_{CC} is listed in Table 8. The component values can be changed to enhance the performance of a particular parameter, but usually at the expense of another. Two variations of the circuit are realized for different requirements for $IP3$ and I_{CC} . Values of external resistors $R1$ and $R2$ are varied to adjust I_{CC} and $IP3$.

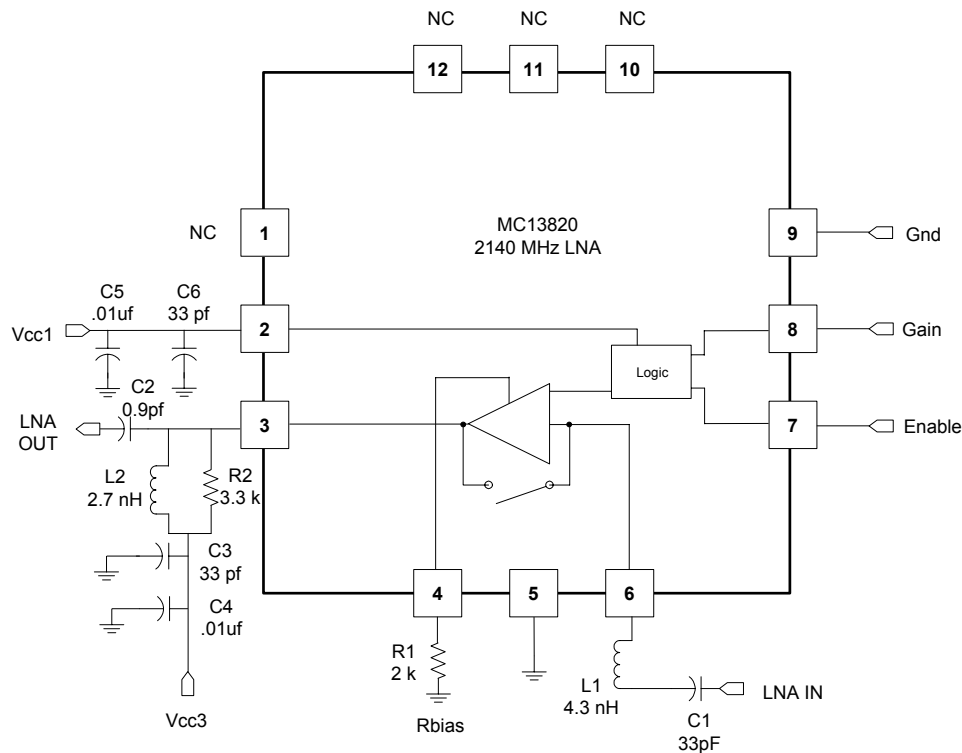

Figure 11. 2140 MHz LNA Application Schematic

Table 8. Typical 2140 MHz LNA Demo Board Performance

(Resistor values of $R1$ and $R2$ are changed for different I_{CC} and $IP3$ requirements.)

Characteristic	Symbol	Min	Typ	Max	Unit
$R1 = 1.2$ kΩ, $R2 = 3.3$ kΩ					
Frequency	f	-	2140	-	MHz
Power Gain	G	-	15.7	-	dB
High Gain		-	15.7	-	
Bypass		-	-3.4	-	
Output Third Order Intercept Point	OIP3	-	20.7	-	dBm
High Gain		-	20.7	-	
Bypass		-	16.4	-	
Input Third Order Intercept Point	IIP3	-	5.0	-	dBm
High Gain		-	5.0	-	
Bypass		-	20	-	

Table 8. Typical 2140 MHz LNA Demo Board Performance (continued)

 (Resistor values of R1 and R2 are changed for different I_{CC} and IP3 requirements.)

Characteristic	Symbol	Min	Typ	Max	Unit
Out Ref P1dB High Gain Bypass	P_{1dBout}	- -	10.7 -	- -	dBm
In Ref P1dB High Gain Bypass	P_{1dBin}	- -	-5.0 -	- -	dBm
Insertion Gain High Gain Bypass	G	- -	14.8 -3.4	- -	dBm
Noise Figure High Gain Bypass	NF	- -	1.49 3.4	- -	dB
Current Drain High Gain Bypass	I_{CC}	- -	4.45 10	- -	mA μ A
Rbias R1 Value		-	1.2	-	k Ω
Rstability R2 Value		-	3.3	-	k Ω
Input Return Loss High Gain Bypass	S11	- -	-8.5 -8.9	- -	dB
Gain High Gain Bypass	S21	- -	16.5 -4.1	- -	dB
Reverse Isolation High Gain Bypass	S12	- -	-22.2 -4.5	- -	dB
Output Return Loss High Gain Bypass	S22	- -	-12.5 -6.1	- -	dB
R1 = 2.0 kΩ, R2 = 3.3 kΩ					
Frequency	f	-	2140	-	MHz
Power Gain High Gain Bypass	G	- -	15.7 -3.2	- -	dB
Output Third Order Intercept Point High Gain Bypass	OIP3	- -	19.7 21.3	- -	dBm
Input Third Order Intercept Point High Gain Bypass	IIP3	- -	3.5 24.5	- -	dBm

Table 8. Typical 2140 MHz LNA Demo Board Performance (continued)
 (Resistor values of R1 and R2 are changed for different I_{CC} and IP3 requirements.)

Characteristic	Symbol	Min	Typ	Max	Unit
Out Ref P1dB High Gain Bypass	P_{1dBout}	- -	10.7 -	- -	dBm
In Ref P1dB High Gain Bypass	P_{1dBin}	- -	-5.0 -	- -	dBm
Insertion Gain High Gain Bypass	G	- -	14.8 -3.5	- -	dBm
Noise Figure High Gain Bypass	NF	- -	1.3 3.2	- -	dB
Current Drain High Gain Bypass	I_{CC}	- -	2.8 10	- -	mA μ A
Rbias R1 Value		-	2.0	-	k Ω
Rstability R2 Value		-	3.3	-	k Ω
Input Return Loss High Gain Bypass	S11	- -	-13.7 -17.1	- -	dB
Gain High Gain Bypass	S21	- -	15.5 -3.0	- -	dB
Reverse Isolation High Gain Bypass	S12	- -	-20.9 -3.3	- -	dB
Output Return Loss High Gain Bypass	S22	- -	-12.1 -14.6	- -	dB

3.4 2400 MHz Application

This application circuit was designed to provide $NF < 1.3$ dB, S_{21} gain > 16 dB, $OIP3$ of 18 dBm with S_{11} better than -10 dB and S_{22} better than -10 dB at 2140 MHz with unconditional stability from 100 MHz to 10 GHz. Typical performance that can be expected from this circuit at 2.75 V V_{CC} is listed in Table 9. The component values can be changed to enhance the performance of a particular parameter, but usually at the expense of another. Two variations of the circuit are realized for different requirements for $IP3$ and I_{CC} . Values of external resistors $R1$ and $R2$ are varied to adjust I_{CC} and $IP3$.

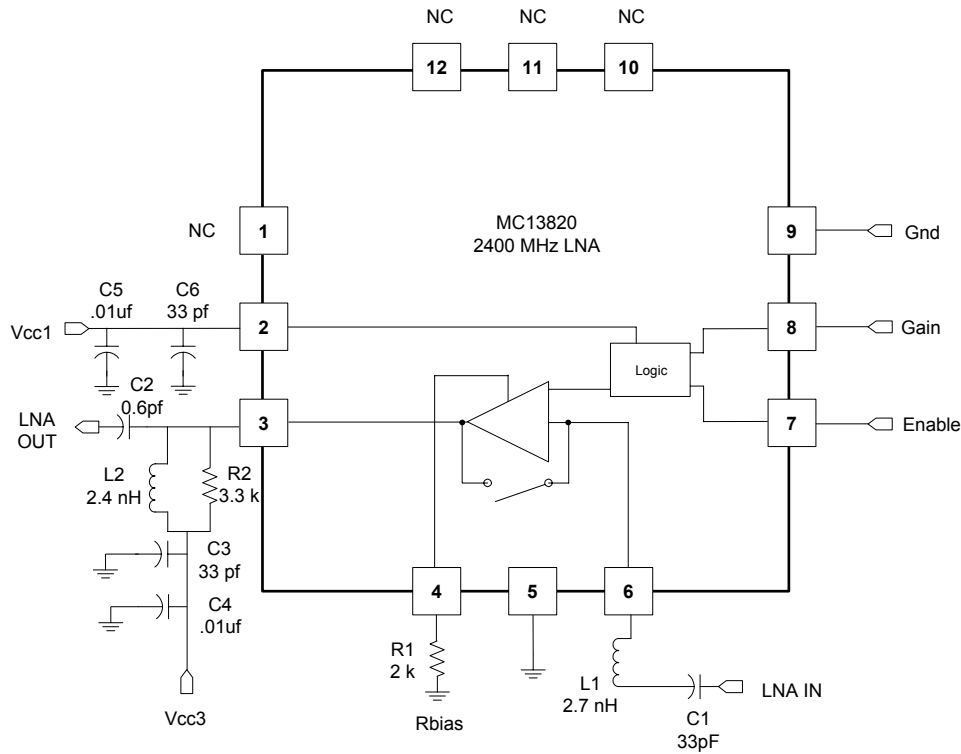

Figure 12. 2400 MHz LNA Application Schematic

Table 9. Typical 2400 MHz LNA Demo Board Performance
(Resistor values of $R1$ and $R2$ are changed for different I_{CC} and $IP3$ requirements.)

Characteristic	Symbol	Min	Typ	Max	Unit
$R1 = 1.2$ kΩ, $R2 = 3.3$ kΩ					
Frequency	f	-	2400	-	MHz
Power Gain	G	-	14	-	dB
High Gain		-	14	-	
Bypass		-	-3.8	-	
Output Third Order Intercept Point	OIP3	-	21	-	dBm
High Gain		-	21	-	
Bypass		-	19	-	
Input Third Order Intercept Point	IIP3	-	7.0	-	dBm
High Gain		-	7.0	-	
Bypass		-	22	-	

Table 9. Typical 2400 MHz LNA Demo Board Performance (continued)

 (Resistor values of R1 and R2 are changed for different I_{CC} and IP3 requirements.)

Characteristic	Symbol	Min	Typ	Max	Unit
Out Ref P1dB High Gain Bypass	P_{1dBout}	- -	10.7 -	- -	dBm
In Ref P1dB High Gain Bypass	P_{1dBin}	- -	-4.0 -	- -	dBm
Insertion Gain High Gain Bypass	G	- -	14 -3.8	- -	dBm
Noise Figure High Gain Bypass	NF	- -	1.55 3.8	- -	dB
Current Drain High Gain Bypass	I_{CC}	- -	4.45 10	- -	mA μ A
Rbias R1 Value		-	1.2	-	k Ω
Rstability R2 Value		-	3.3	-	k Ω
Input Return Loss High Gain Bypass	S11	- -	-8.5 -8.9	- -	dB
Gain High Gain Bypass	S21	- -	14.5 -4.1	- -	dB
Reverse Isolation High Gain Bypass	S12	- -	-20.2 -4.0	- -	dB
Output Return Loss High Gain Bypass	S22	- -	-11 -7.0	- -	dB
R1 = 2.0 kΩ, R2 = 3.3 kΩ					
Frequency	f	-	2400	-	MHz
Power Gain High Gain Bypass	G	- -	14 -3.6	- -	dB
Output Third Order Intercept Point High Gain Bypass	OIP3	- -	18.5 20	- -	dBm
Input Third Order Intercept Point High Gain Bypass	IIP3	- -	4.0 24	- -	dBm

Table 9. Typical 2400 MHz LNA Demo Board Performance (continued)
 (Resistor values of R1 and R2 are changed for different I_{CC} and IP3 requirements.)

Characteristic	Symbol	Min	Typ	Max	Unit
Out Ref P1dB High Gain Bypass	P_{1dBout}	- -	10 -	- -	dBm
In Ref P1dB High Gain Bypass	P_{1dBin}	- -	-4.0 -	- -	dBm
Insertion Gain High Gain Bypass	G	- -	14 -4.0	- -	dBm
Noise Figure High Gain Bypass	NF	- -	1.49 4.2	- -	dB
Current Drain High Gain Bypass	I_{CC}	- -	2.8 10	- -	mA μ A
Rbias R1 Value		-	2.0	-	k Ω
Rstability R2 Value		-	3.3	-	k Ω
Input Return Loss High Gain Bypass	S11	- -	-10 -9.7	- -	dB
Gain High Gain Bypass	S21	- -	14 -3.6	- -	dB
Reverse Isolation High Gain Bypass	S12	- -	-20 -3.8	- -	dB
Output Return Loss High Gain Bypass	S22	- -	-10 -9.1	- -	dB

4 Printed Circuit Board

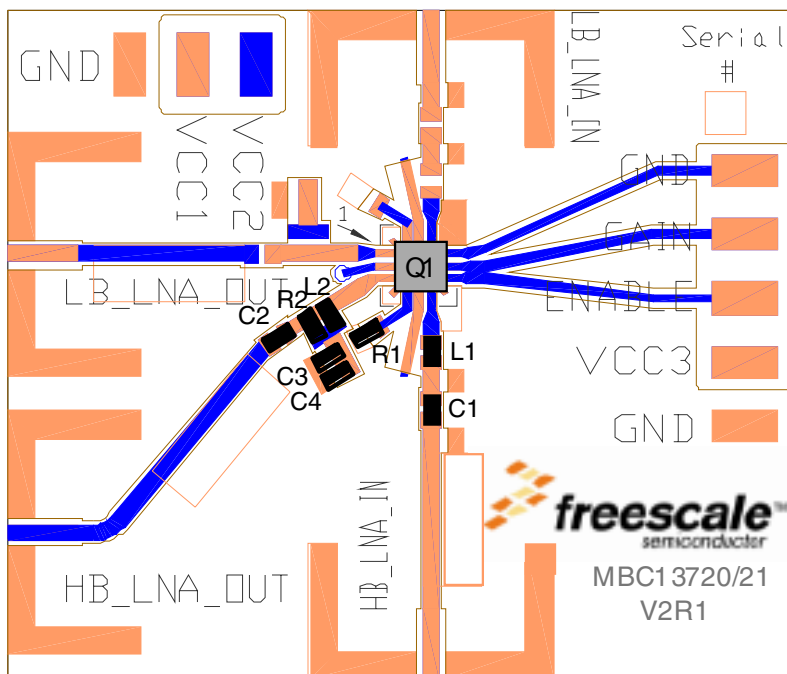

NOTE: COMPONENTS C5 AND C6 ARE LOCATED ON THE BACK OF THE BOARD

Figure 13. Front Side

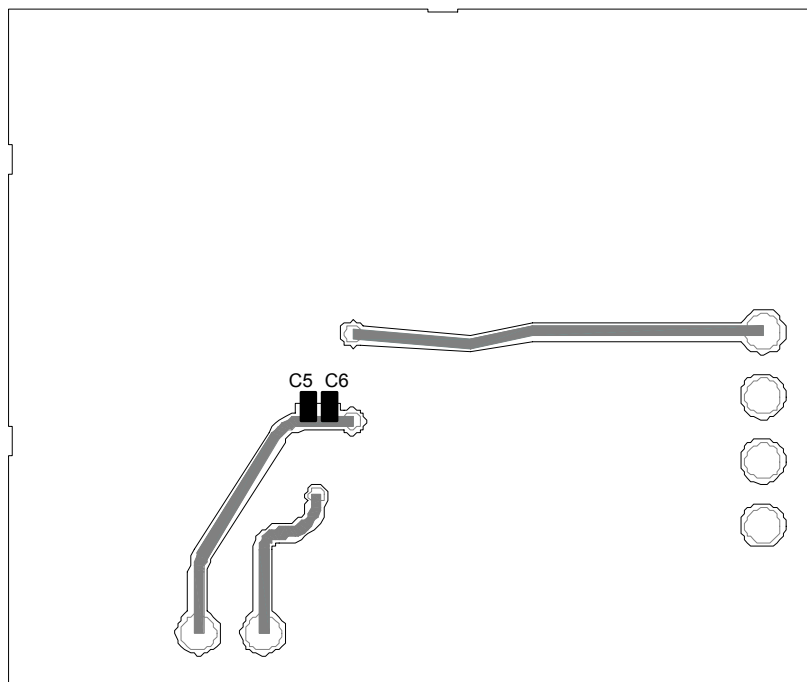

Figure 14. Back Side

Table 10. Bill of Materials

Component	Value	Case	Manufacturer	Comments
1575 MHz				
C1	22 pF	402	Murata	Input match
C2	1.0 pF	402	Taiyo Yuden	Output match
C3	33 pF	402	Murata	RF bypass
C4	.01 μ F	402	Murata	Low freq bypass
C5	.01 μ F	402	Murata	Low freq bypass
C6	33 pF	402	Murata	RF bypass
L2	5.6 nH	1005	CoilCraft	Output match
L1	5.6 nH	1005	CoilCraft	Input match
R1	1.2 or 2 k Ω	402	KOA	Bias for 4.45 or 2.8 mA
R2	680 Ω	402	KOA	Stability
Q1	MC13820	QFN-12	Freescale	
1960 MHz				
C1	33 pF	402	Murata	Input match
C2	0.9 pF	402	Taiyo Yuden	Output match
C3	33 pF	402	Murata	RF bypass
C4	.01 μ F	402	Murata	Low freq bypass
C5	.01 μ F	402	Murata	Low freq bypass
C6	33 pF	402	Murata	RF bypass
L1	4.3 nH	1005	CoilCraft	Input match
L2	2.7 nH	1005	Coilcraft	Output match
R1	1.2 or 2 k Ω	402	KOA	Bias for 4.45 or 2.8 mA
R2	3.3 k Ω	402	KOA	Stability
Q1	MC13820	QFN-12	Freescale	
2140 MHz				
C1	33 pF	402	Murata	Input match
C2	0.9 pF	402	Taiyo Yuden	Output match
C3	33 pF	402	Murata	RF bypass
C4	.01 μ F	402	Murata	Low freq bypass
C5	.01 μ F	402	Murata	Low freq bypass
C6	33 pF	402	Murata	RF bypass
L1	4.3 nH	1005	CoilCraft	Input match
L2	2.7 nH	1005	CoilCraft	Output match

Table 10. Bill of Materials (continued)

Component	Value	Case	Manufacturer	Comments
R2	3.3 k Ω	402	KOA	Stability
R1	1.2 or 2 k Ω	402	KOA	Bias for 4.45 or 2.8 mA
Q1	MC13820	QFN-12	Freescale	
2400 MHz				
C1	33 pF	402	Murata	Input match
C2	0.6 pF	402	Taiyo Yuden	Output match
C3	33 pF	402	Murata	RF bypass
C4	.01 μ F	402	Murata	Low freq bypass
C5	.01 μ F	402	Murata	Low freq bypass
C6	33 pF	402	Murata	RF bypass
L1	2.7 nH	1005	CoilCraft	Input match
L2	2.4 nH	1005	CoilCraft	Output match
R2	1.2 or 2 k Ω	402	KOA	Bias for 4.45 or 2.8 mA
R1	3.3 k Ω	402	KOA	Stability
Q1	MC13820	QFN-12	Freescale	

5 Scattering Parameters

Table 11. Active Mode Scattering Parameters

 (V_{CC1} and $V_{CC3} = 2.75$ V, Band grounded, Gain = 2.75 V, Enable = 2.75 V, Rbias resistor R1 = 2 k Ω), $I_{CC} = 2.6$ mA

f GHz)	S ₁₁		S ₂₁		S ₁₂		S ₂₂	
	S ₁₁	$\angle \phi$	S ₁₁	$\angle \phi$	S ₁₁	$\angle \phi$	S ₁₁	$\angle \phi$
0.7	0.852	-29.22	7.029	142.03	0.021	75.16	0.956	-14.42
0.8	0.836	-32.9	7.279	137.43	0.024	73.13	0.946	-15.76
0.9	0.803	-36.02	7.034	133.48	0.027	70.95	0.966	-19.49
1	0.814	-42.84	6.856	127	0.029	66.71	0.887	-17.77
1.1	0.782	-42.6	6.687	125.21	0.031	68.53	0.924	-22.03
1.2	0.772	-45.55	6.29	122.03	0.034	65.83	0.898	-23.58
1.3	0.752	-47.28	6.242	116.95	0.036	65.66	0.897	-25.56
1.4	0.718	-50.24	6.082	114.12	0.039	64.76	0.912	-26.44
1.5	0.672	-52.29	5.696	112.14	0.04	61.29	0.943	-30.51
1.6	0.688	-49.98	5.662	107.49	0.043	61.9	0.882	-35.18
1.7	0.695	-53.95	5.499	104.8	0.044	60.95	0.865	-35.67
1.8	0.686	-54.86	5.348	101.62	0.047	60.42	0.866	-36.55
1.9	0.653	-57.19	5.334	97.81	0.05	59.47	0.892	-41.25
2	0.661	-57.81	5.098	95.37	0.052	60.14	0.863	-42.78
2.1	0.646	-60.4	5.035	90.65	0.058	56	0.844	-46.94
2.2	0.639	-62.48	4.766	86.29	0.058	52.65	0.818	-49.01
2.3	0.628	-61.9	4.575	86.75	0.059	51.95	0.8	-50.61
2.4	0.608	-63.13	4.529	82.12	0.06	52.38	0.78	-51.67
2.5	0.61	-63.96	4.366	79.31	0.063	53.62	0.779	-52.93
2.6	0.609	-65.96	4.251	77.33	0.067	51.2	0.777	-54.38
2.7	0.637	-69.48	4.307	75.4	0.072	50.86	0.811	-57.38
2.8	0.57	-74.63	4.168	68.94	0.073	46.36	0.756	-63.02
2.9	0.536	-75.03	3.933	65.73	0.075	42.72	0.716	-62.94
3	0.515	-75.6	3.819	62.83	0.074	42.14	0.697	-64.16
3.1	0.506	-75.28	3.665	61.56	0.074	39.24	0.683	-63.26
3.2	0.489	-73.7	3.572	60.5	0.07	39.17	0.702	-63.69
3.3	0.483	-74.54	3.523	58.09	0.07	43.49	0.716	-66.71
3.4	0.487	-76.91	3.495	55.25	0.075	46.63	0.714	-70.44
3.5	0.488	-78.25	3.484	51.93	0.082	45.9	0.699	-74.6

Table 12. Bypass Mode Scattering Parameters

 ((V_{CC1} and $V_{CC3} = 2.75V$, Band and Gain grounded, Enable = 2.75 V, Rbias resistor R1= 2 k Ω), $I_{CC} = 3.0 \mu A$)

f (GHz)	S ₁₁		S ₂₁		S ₁₂		S ₂₂	
	S ₁₁	$\angle \phi$	S ₁₁	$\angle \phi$	S ₁₁	$\angle \phi$	S ₁₁	$\angle \phi$
0.7	0.549	-51.13	0.578	17.83	0.583	18.83	0.578	-41.21
0.8	0.511	-53.94	0.596	13.17	0.6	14.15	0.542	-42.25
0.9	0.47	-55.73	0.608	8.45	0.614	10.08	0.524	-45.13
1	0.458	-59.65	0.615	3.3	0.617	5.12	0.455	-43.82
1.1	0.434	-58.46	0.624	1.11	0.628	2.52	0.453	-46.74
1.2	0.421	-59.33	0.629	-2.37	0.635	-0.96	0.42	-48.02
1.3	0.404	-59.6	0.634	-5.19	0.639	-3.8	0.407	-48.56
1.4	0.384	-61.06	0.633	-8.02	0.639	-6.66	0.394	-47.62
1.5	0.36	-62.48	0.638	-10.97	0.641	-9.5	0.388	-49.7
1.6	0.362	-59.49	0.638	-13.09	0.643	-11.89	0.374	-53.61
1.7	0.367	-60.21	0.639	-15.43	0.643	-14.26	0.353	-53.66
1.8	0.363	-60.18	0.64	-17.77	0.645	-16.58	0.335	-53.3
1.9	0.35	-63.26	0.645	-20.27	0.649	-19.08	0.348	-53.86
2	0.355	-63.18	0.639	-22.63	0.643	-21.39	0.327	-54.83
2.1	0.335	-66.36	0.64	-24.42	0.643	-23.2	0.342	-57.82
2.2	0.332	-65.87	0.64	-26.93	0.645	-25.56	0.324	-60.95
2.3	0.322	-63.97	0.64	-28.95	0.644	-27.79	0.309	-63.15
2.4	0.32	-63.46	0.639	-31.11	0.642	-30.01	0.294	-64.43
2.5	0.319	-63.28	0.632	-33.88	0.638	-32.07	0.279	-64.25
2.6	0.323	-63.96	0.627	-35.14	0.633	-33.64	0.274	-62.49
2.7	0.354	-65.66	0.64	-36.78	0.645	-35.11	0.297	-62.47
2.8	0.317	-73.59	0.637	-40.56	0.643	-38.92	0.282	-72.82
2.9	0.296	-74.61	0.622	-42.77	0.629	-41.1	0.245	-73.08
3	0.284	-74.6	0.616	-44.14	0.621	-42.65	0.23	-70.36
3.1	0.283	-72.89	0.616	-45.7	0.619	-43.94	0.236	-67.03
3.2	0.274	-72.04	0.618	-47.38	0.622	-45.84	0.245	-68.8
3.3	0.269	-74.74	0.618	-50.21	0.623	-48.62	0.238	-75.51
3.4	0.265	-77.34	0.609	-52.62	0.615	-51.03	0.212	-77.5
3.5	0.261	-76.71	0.603	-54.36	0.607	-52.96	0.194	-77.94

Table 13. Active Mode Scattering Parameters

(V_{CC1} and $V_{CC3} = 2.75$ V, Band grounded, Gain and Enable = 2.75 V, Rbias resistor R1 = 1.2 k Ω , $I_{CC} = 4.8$ mA)

f (GHz)	S ₁₁		S ₂₁		S ₁₂		S ₂₂	
	S ₁₁	$\angle \phi$	S ₁₁	$\angle \phi$	S ₁₁	$\angle \phi$	S ₁₁	$\angle \phi$
0.7	0.784	-32.04	10.275	132.74	0.021	72.91	0.92	-15.77
0.8	0.765	-35.9	10.162	127.59	0.022	71.83	0.907	-16.82
0.9	0.721	-39	9.646	122.89	0.025	68.97	0.923	-20.31
1	0.724	-45.16	9.184	116.28	0.027	67.34	0.842	-18.21
1.1	0.692	-44.87	8.773	114.36	0.029	67.52	0.877	-22.39
1.2	0.678	-47.17	8.23	110.64	0.033	67.56	0.846	-23.69
1.3	0.662	-48.64	7.98	106.21	0.034	66.62	0.845	-25.47
1.4	0.626	-51.75	7.638	103.36	0.037	64.27	0.858	-25.98
1.5	0.576	-53.11	7.185	100.91	0.039	63.47	0.893	-29.67
1.6	0.594	-49.59	6.972	96.71	0.041	62.78	0.835	-34.46
1.7	0.599	-52.85	6.691	93.81	0.042	62.14	0.816	-34.49
1.8	0.594	-54.14	6.444	90.92	0.044	62.34	0.817	-35.3
1.9	0.56	-56.18	6.34	87.3	0.049	60.88	0.843	-39.86
2	0.568	-57.13	6.029	85.12	0.05	60.42	0.817	-41.18
2.1	0.548	-58.62	5.885	80.96	0.054	57.9	0.798	-45.47
2.2	0.546	-59.79	5.568	76.96	0.056	56.61	0.774	-46.98
2.3	0.543	-59.25	5.318	76.8	0.057	54.83	0.761	-48.63
2.4	0.532	-59.9	5.189	72.95	0.059	54.79	0.742	-49.56
2.5	0.527	-61.63	4.979	70.13	0.062	53.59	0.741	-50.7
2.6	0.529	-62.78	4.816	68.35	0.064	53.44	0.743	-52
2.7	0.551	-67.21	4.839	66.22	0.072	52.3	0.768	-55.57
2.8	0.485	-70.76	4.649	60.62	0.072	47.22	0.715	-60.12
2.9	0.454	-71.28	4.382	57.65	0.074	44.14	0.68	-60.09
3	0.434	-70.94	4.207	55.39	0.072	42.21	0.666	-60.36
3.1	0.433	-67.82	4.048	54.44	0.068	41.81	0.669	-60.12
3.2	0.436	-66.18	3.936	52.8	0.069	43.96	0.674	-61.04
3.3	0.437	-68.3	3.847	50.72	0.072	47.68	0.684	-63.24
3.4	0.437	-72.51	3.81	48.36	0.078	46.81	0.687	-66.49
3.5	0.433	-73.15	3.767	45.48	0.082	45.71	0.676	-70.55

Table 14. Bypass Mode Scattering Parameters

 (V_{CC1} and $V_{CC3} = 2.75$ V, Band and Gain grounded, Enable = 2.75 V, Rbias resistor R1 = 1.2 k Ω , $I_{CC} = 3$ μ A)

f (GHz)	S ₁₁		S ₂₁		S ₁₂		S ₂₂	
	S ₁₁	$\angle \phi$	S ₁₁	$\angle \phi$	S ₁₁	$\angle \phi$	S ₁₁	$\angle \phi$
0.7	0.556	-44.11	0.573	20.27	0.573	20.39	0.595	-42.94
0.8	0.514	-46.8	0.591	15.11	0.591	15.3	0.549	-43.78
0.9	0.475	-49.46	0.6	10.38	0.599	10.66	0.511	-43.02
1	0.459	-50.05	0.618	6.77	0.617	6.98	0.479	-46.66
1.1	0.427	-50.66	0.623	3.34	0.621	3.51	0.462	-47.17
1.2	0.412	-51.99	0.633	-0.34	0.632	-0.19	0.43	-49.25
1.3	0.391	-52.85	0.635	-3.09	0.634	-2.98	0.421	-49.35
1.4	0.379	-53.91	0.637	-6.45	0.636	-6.18	0.395	-50.53
1.5	0.368	-53.94	0.638	-8.92	0.638	-8.66	0.384	-51.37
1.6	0.358	-54.86	0.64	-11.49	0.639	-11.33	0.374	-52.64
1.7	0.352	-55.36	0.641	-14.09	0.64	-13.92	0.358	-53.9
1.8	0.346	-55.58	0.641	-16.37	0.641	-16.17	0.345	-54.87
1.9	0.341	-55.61	0.641	-18.68	0.641	-18.47	0.334	-56.07
2	0.334	-56.07	0.638	-20.97	0.639	-20.85	0.321	-56.45
2.1	0.329	-56.92	0.635	-23.12	0.633	-22.91	0.312	-56.2
2.2	0.319	-57.96	0.636	-24.75	0.636	-24.45	0.314	-57.47
2.3	0.308	-57.61	0.64	-26.81	0.64	-26.59	0.306	-59.76
2.4	0.299	-57.89	0.641	-29.13	0.64	-28.92	0.295	-61.28
2.5	0.293	-59.25	0.64	-31.4	0.642	-31.04	0.291	-62.5
2.6	0.285	-60.49	0.636	-33.55	0.636	-33.11	0.277	-62.84
2.7	0.279	-62.48	0.636	-35.59	0.635	-35.51	0.272	-65.72
2.8	0.274	-64.02	0.634	-37.84	0.633	-37.69	0.258	-67.26
2.9	0.267	-66.58	0.629	-39.74	0.63	-39.66	0.247	-67.95
3	0.27	-68.28	0.623	-42.19	0.623	-42.06	0.232	-68.55
3.1	0.264	-70.53	0.618	-43.48	0.616	-43.19	0.241	-64.77
3.2	0.261	-72.44	0.617	-45.42	0.616	-45.19	0.241	-69.24
3.3	0.26	-73.31	0.616	-47.61	0.615	-47.35	0.227	-74.2
3.4	0.26	-73.49	0.613	-49.49	0.613	-49.26	0.209	-76.39
3.5	0.265	-73.26	0.61	-52.15	0.61	-51.84	0.179	-78.56

Table 15. Noise Parameters

($V_{CC} = 2.7\text{ V}$, Enable = 2.75 V, Rbias = 1.2 k Ω , $I_{CC} = 4.8\text{ mA}$)

f (GHz)	NFmin (dB)	Gamma Opt		Rn (Ω)	rn (Ω)	G _{NF} (dB)	K
		Mag	Ang				
1	1.11	0.27	25.3	14	0.28	26.21	0.63
1.575	0.99	0.29	40.8	13	0.26	22.63	0.74
1.9	0.96	0.30	46.9	12.5	0.25	20.83	0.70
2.14	0.96	0.30	50.1	12.5	0.25	19.8	0.78
2.4	0.97	0.30	54.0	12	0.24	18.3	0.89

Table 16. Noise Parameters

($V_{CC} = 2.7\text{ V}$, Enable = 2.75 V, Rbias = 2 k Ω , $I_{CC} = 2.8\text{ mA}$)

f (GHz)	NFmin (dB)	Gamma Opt		Rn (Ω)	rn (Ω)	G _{NF} (dB)	K
		Mag	Ang				
1	1.16	0.23	27.6	15.5	0.31	26.09	0.48
1.575	1.02	0.35	39.0	15	0.3	22.57	0.56
1.9	0.97	0.37	46.2	14	0.28	20.81	0.53
2.14	0.96	0.37	49.7	14	0.28	19.79	0.61
2.4	0.95	0.37	54.1	13.5	0.27	18.3	0.77

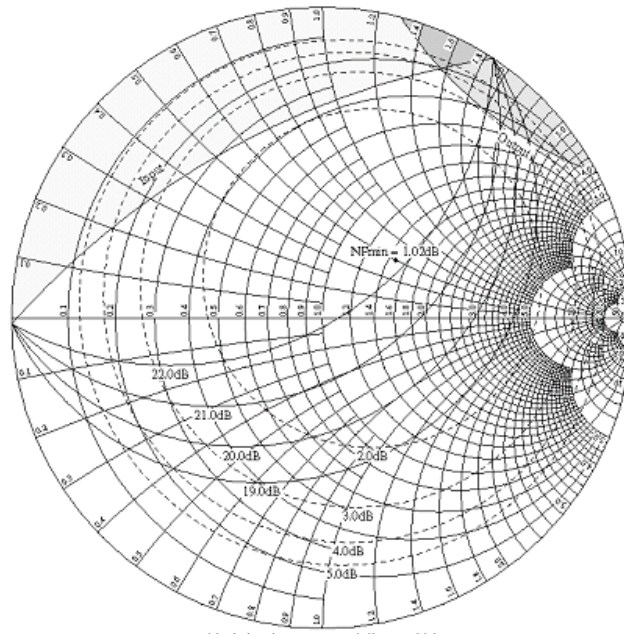

(shaded regions are potentially unstable)

f(GHz)	NFmin	Gamma-Opt	Rn (Ω)	K
1.575	1.02	0.30/_38.2	13.5	0.74

Figure 15. Constant Noise Figure and Gain Circles. 1575 MHz, Rbias = 1.2 k Ω

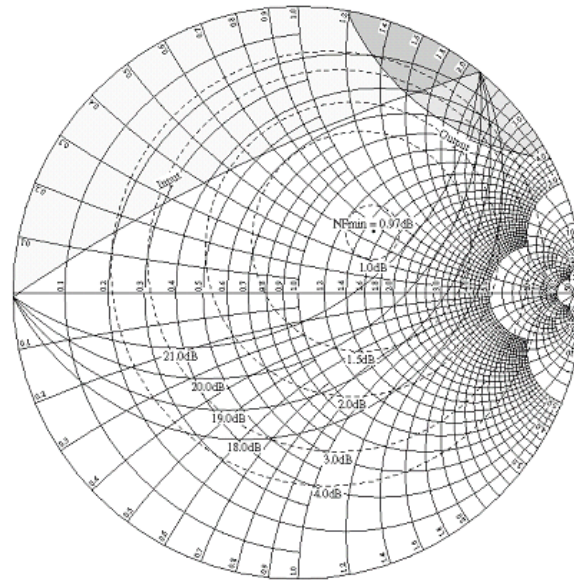

(shaded regions are potentially unstable)

f(GHz)	NFmin	Gamma-Opt	Rn (Ω)	K
1.575	0.97	0.34/_39.1	17.0	0.56

Figure 16. Constant Noise Figure and Gain Circles. 1575 MHz, Rbias = 2 k Ω

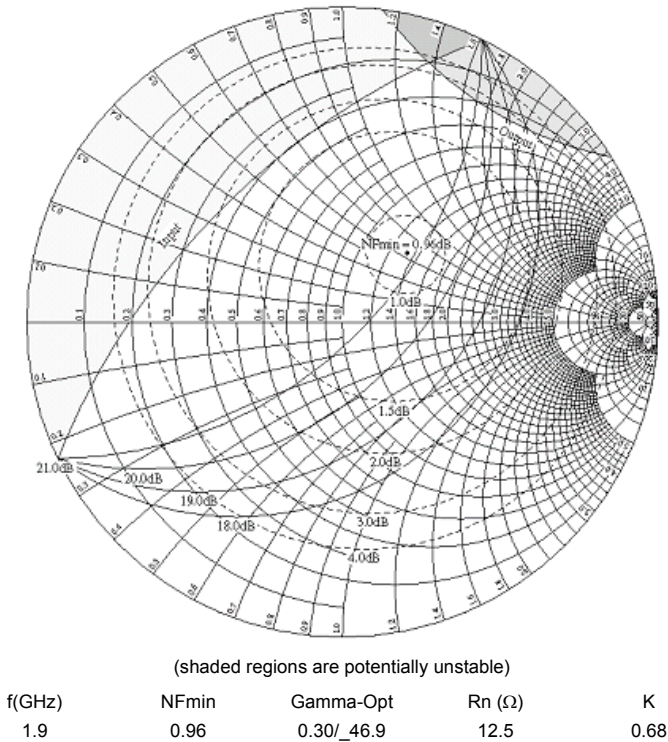

Figure 17. Constant Noise Figure and Gain Circles. 1900 MHz, Rbias = 1.2 kΩ

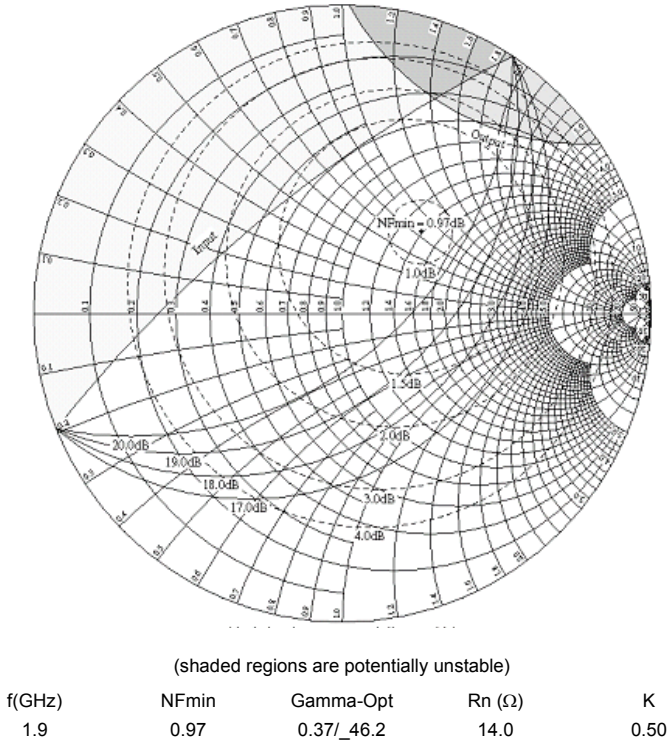
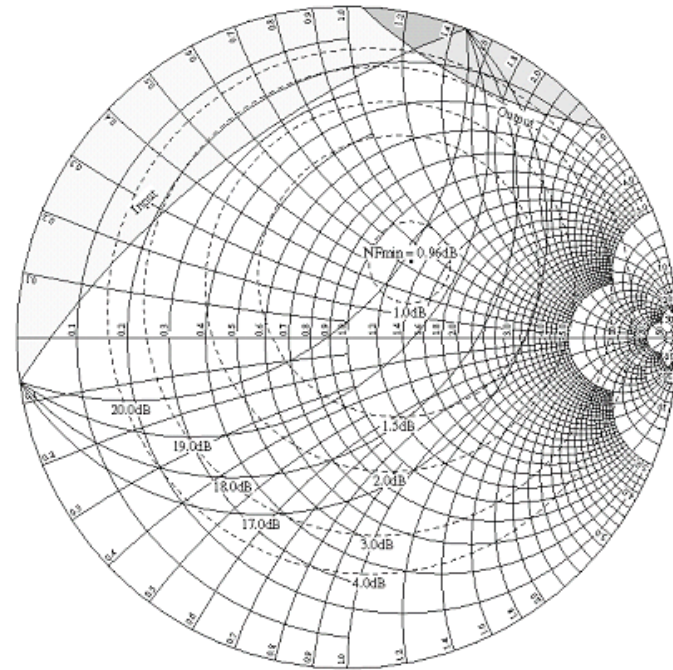

Figure 18. Constant Noise Figure and Gain Circles. 1900 MHz, Rbias = 2 kΩ



(shaded regions are potentially unstable)

f(GHz)	NFmin	Gamma-Opt	Rn (Ω)	K
2.1	0.96	0.30/_50.1	12.5	0.76

Figure 19. Constant Noise Figure and Gain Circles. 2140 MHz, Rbias =1.2 k Ω

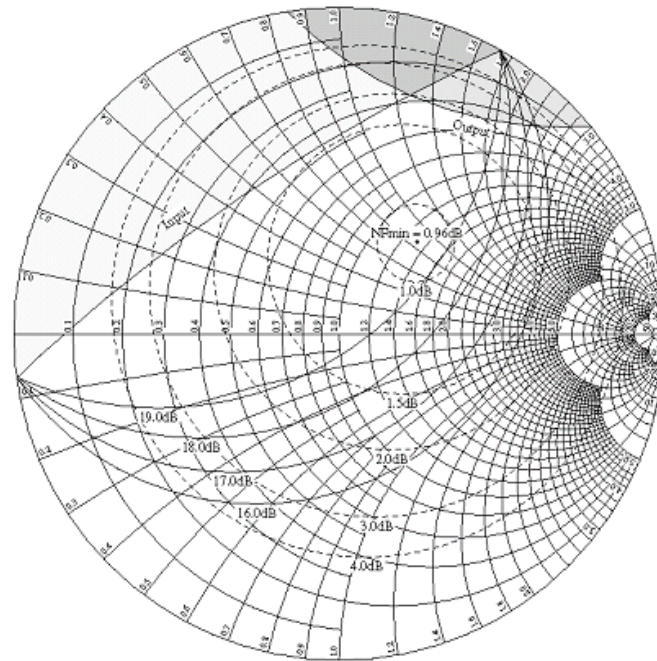

(shaded regions are potentially unstable)

f(GHz)	NFmin	Gamma-Opt	Rn (Ω)	K
2.1	0.96	0.37/_49.7	14.0	0.58

Figure 20. Constant Noise Figure and Gain Circles. 2140 MHz, Rbias =1.2 k Ω

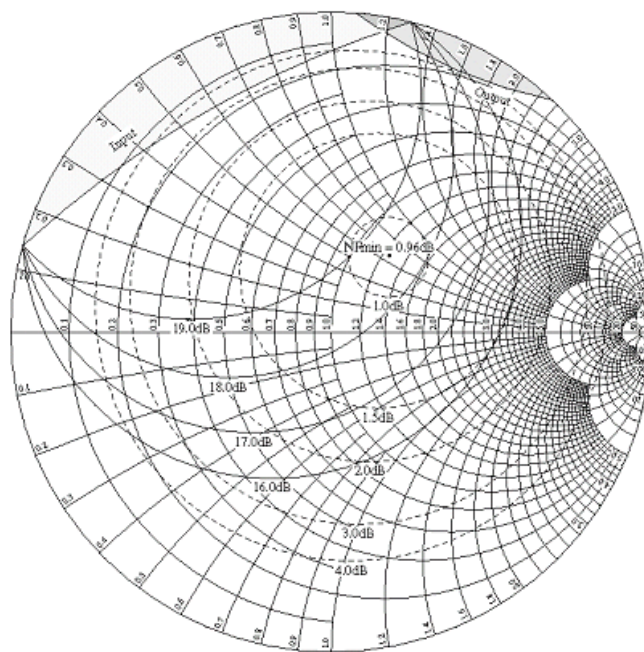

(shaded regions are potentially unstable)

f(GHz)	NFmin	Gamma-Opt	Rn (Ω)	K
2.3	0.96	0.30/_52.8	12.0	0.85

Figure 21. Constant Noise Figure and Gain Circles. 2400 MHz, Rbias = 1.2 k Ω

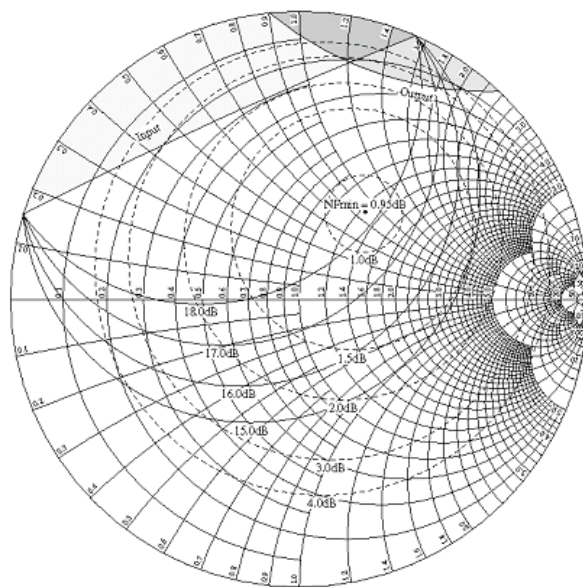

(shaded regions are potentially unstable)

f(GHz)	NFmin	Gamma-Opt	Rn (Ω)	K
2.3	0.95	0.38/_53	13.5	0.70

Figure 22. Constant Noise Figure and Gain Circles. 2400 MHz, Rbias = 2 k Ω

6 Packaging

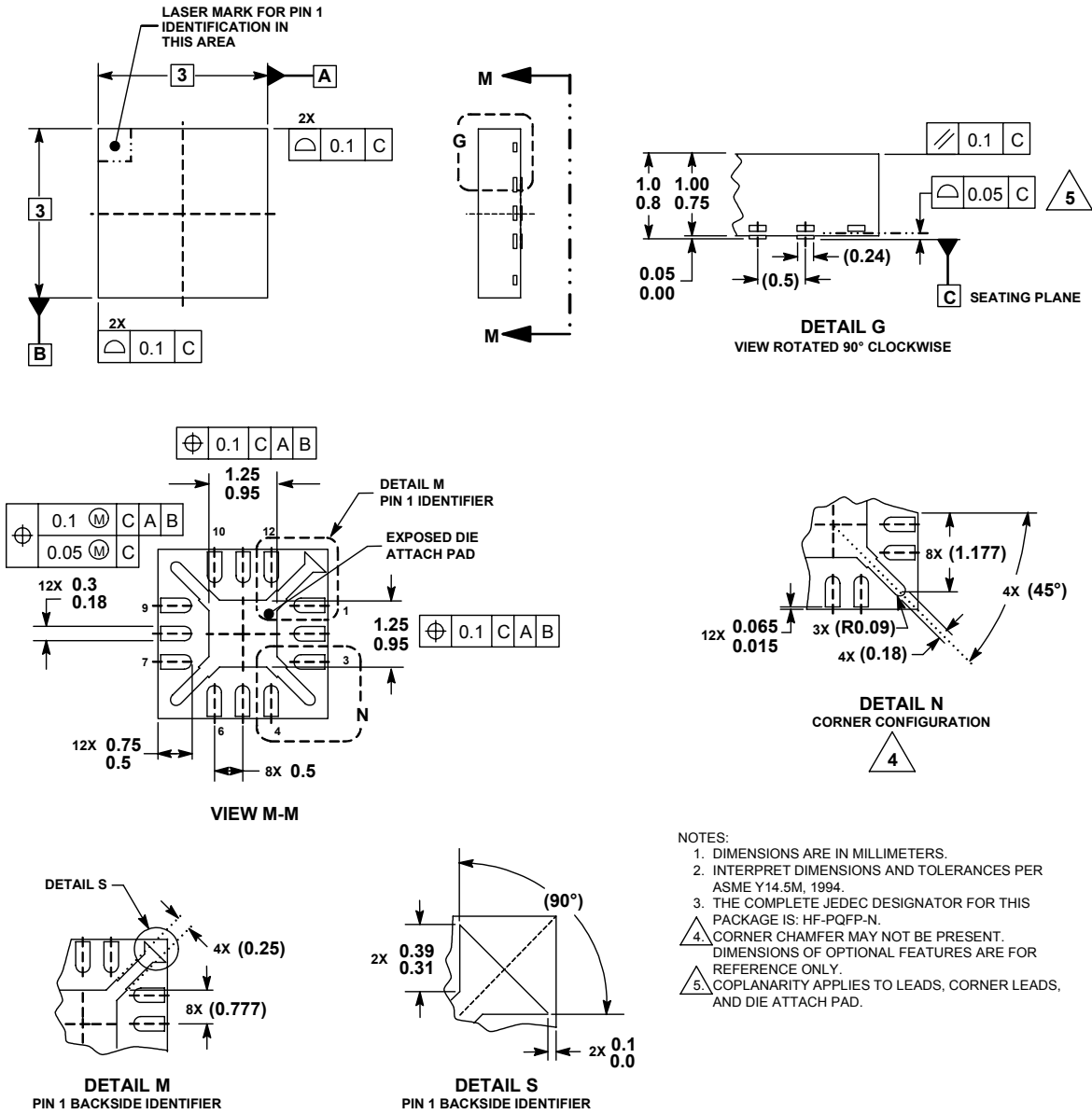

Figure 23. Outline Dimensions for QFN-12
(Case Outline 1345-01, Issue A)

7 Product Documentation

This data sheet is labeled as a particular type: Product Preview, Advance Information, or Technical Data. Definitions of these types are available at: <http://www.freescale.com>.

Table 17 summarizes revisions made to this document since Rev. 1.0 was released.

Table 17. Revision History

Location	Revision
Section 1.1, “Features”, on page 1	Updated text.
Table 1 Maximum Ratings	Updated Thermal Resistance, Junction to Case and added Thermal Resistance, Junction to Ambient, 4 layer board.
Table 2 Recommended Operating Conditions	Updated Logic Voltage.
Table 5 Truth Table	Added notes.
Table 6 Typical 1575 MHz LNA Demo Board Performance	Updated Current Drain Typ numbers.
Table 7 Typical 1960 MHz LNA Demo Board Performance	Updated Current Drain.
Table 8 Typical 2140 MHz LNA Demo Board Performance	Updated to R1 = 2.0 kΩ, R2 = 3.3 kΩ.
Table 9 Typical 2400 MHz LNA Demo Board Performance	Updated to R1 = 2.0 kΩ, R2 = 3.3 kΩ.
Table 10 Bill of Materials	Updated 1575 MHz R1, 1960 MHz R1, 2140 MHz R1, and 2400 MHz R2.
Figure 13 Front Side of Printed Circuit Board	Updated.

NOTES

How to Reach Us:

Home Page:
www.freescale.com

E-mail:
support@freescale.com

USA/Europe or Locations Not Listed:
Freescale Semiconductor
Technical Information Center, CH370
1300 N. Alma School Road
Chandler, Arizona 85224
+1-800-521-6274 or +1-480-768-2130
support@freescale.com

Europe, Middle East, and Africa:
Freescale Halbleiter Deutschland GmbH
Technical Information Center
Schatzbogen 7
81829 Muenchen, Germany
+44 1296 380 456 (English)
+46 8 52200080 (English)
+49 89 92103 559 (German)
+33 1 69 35 48 48 (French)
support@freescale.com

Japan:
Freescale Semiconductor Japan Ltd.
Headquarters
ARCO Tower 15F
1-8-1, Shimo-Meguro, Meguro-ku,
Tokyo 153-0064, Japan
0120 191014 or +81 3 5437 9125
support.japan@freescale.com

Asia/Pacific:
Freescale Semiconductor Hong Kong Ltd.
Technical Information Center
2 Dai King Street
Tai Po Industrial Estate
Tai Po, N.T., Hong Kong
+800 2666 8080
support.asia@freescale.com

For Literature Requests Only:
Freescale Semiconductor Literature Distribution Center
P.O. Box 5405
Denver, Colorado 80217
1-800-521-6274 or 303-675-2140
Fax: 303-675-2150
LDCForFreescaleSemiconductor@hibbertgroup.com

Information in this document is provided solely to enable system and software implementers to use Freescale Semiconductor products. There are no express or implied copyright licenses granted hereunder to design or fabricate any integrated circuits or integrated circuits based on the information in this document.

Freescale Semiconductor reserves the right to make changes without further notice to any products herein. Freescale Semiconductor makes no warranty, representation or guarantee regarding the suitability of its products for any particular purpose, nor does Freescale Semiconductor assume any liability arising out of the application or use of any product or circuit, and specifically disclaims any and all liability, including without limitation consequential or incidental damages. "Typical" parameters that may be provided in Freescale Semiconductor data sheets and/or specifications can and do vary in different applications and actual performance may vary over time. All operating parameters, including "Typicals", must be validated for each customer application by customer's technical experts. Freescale Semiconductor does not convey any license under its patent rights nor the rights of others. Freescale Semiconductor products are not designed, intended, or authorized for use as components in systems intended for surgical implant into the body, or other applications intended to support or sustain life, or for any other application in which the failure of the Freescale Semiconductor product could create a situation where personal injury or death may occur. Should Buyer purchase or use Freescale Semiconductor products for any such unintended or unauthorized application, Buyer shall indemnify and hold Freescale Semiconductor and its officers, employees, subsidiaries, affiliates, and distributors harmless against all claims, costs, damages, and expenses, and reasonable attorney fees arising out of, directly or indirectly, any claim of personal injury or death associated with such unintended or unauthorized use, even if such claim alleges that Freescale Semiconductor was negligent regarding the design or manufacture of the part.

Freescale™ and the Freescale logo are trademarks of Freescale Semiconductor, Inc. All other product or service names are the property of their respective owners.

© Freescale Semiconductor, Inc. 2005. All rights reserved.

Looking for pricing, stock, or lifecycle information?

Click below to explore more details on WIN SOURCE:

- ⊖ [View MC13820FCR2 on WIN SOURCE](#)
- ⊖ [Freescale Semiconductor - NXP Information](#)

Optimize Your Supply Chain with WIN SOURCE Solutions

- ✓ Global Sourcing Solution
- ✓ Obsolete Management
- ✓ Cost Control Management
- ✓ Shortage Management
- ✓ Alternative Solution
- ✓ Excess Inventory Management