



**THE DATASHEET OF  
MC10H350MEL**



# MC10H350

## PECL\* to TTL Translator

(+5 Vdc Power Supply Only)

### Description

The MC10H350 is a member of the 10H family of high performance ECL logic. It consists of 4 translators with differential inputs and TTL outputs. The 3-state outputs can be disabled by applying a HIGH TTL logic level on the common OE input.

The MC10H350 is designed to be used primarily in systems incorporating both ECL and TTL logic operating off a common power supply. The separate  $V_{CC}$  power pins are not connected internally and thus isolate the noisy TTL  $V_{CC}$  runs from the relatively quiet ECL  $V_{CC}$  runs on the printed circuit board. The differential inputs allow the MC10H350 to be used as an inverting or noninverting translator, or a differential line receiver. The MC10H350 can also drive CMOS with the addition of a pullup resistor.

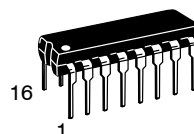
### Features

- Propagation Delay, 3.5 ns Typical
- MECL 10K™ Compatible
- These Devices are Pb-Free, Halogen Free and are RoHS Compliant

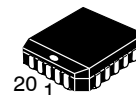


ON Semiconductor®

[www.onsemi.com](http://www.onsemi.com)

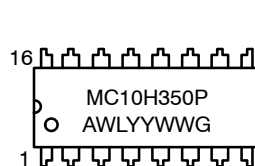


PDIP-16  
P SUFFIX  
CASE 648-08

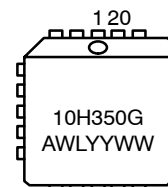


PLLCC-20  
FN SUFFIX  
CASE 775-02

### MARKING DIAGRAMS\*



PDIP-16



PLLCC-20

A = Assembly Location  
WL, L = Wafer Lot  
YY, Y = Year  
WW, W = Work Week  
G = Pb-Free Package

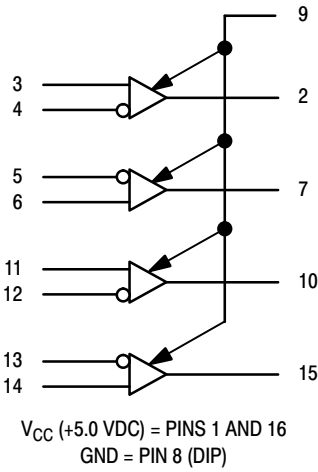
\*For additional marking information, refer to Application Note [AND8002/D](#).

### ORDERING INFORMATION

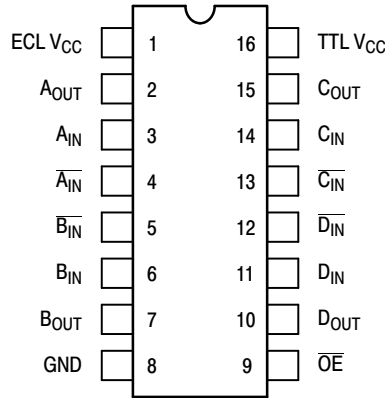
Device	Package	Shipping†
MC10H350FNG	PLLCC-20 (Pb-Free)	46 Units / Tube
MC10H350FNR2G	PLLCC-20 (Pb-Free)	500 Tape & Reel
MC10H350PG	PDIP-16 (Pb-Free)	25 Units / Tube

†For information on tape and reel specifications, including part orientation and tape sizes, please refer to our Tape and Reel Packaging Specifications Brochure, [BRD8011/D](#).

# MC10H350

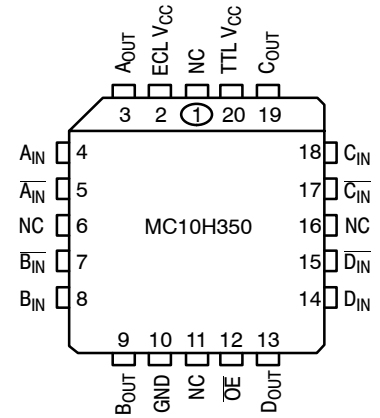


**Figure 1. Logic Diagram**



Pin assignment is for Dual-in-Line Package.

**Figure 2. Dip Pin Assignment**



**Figure 3. PLCC-20 Pin Assignment**

**Table 1. MAXIMUM RATINGS**

Symbol	Characteristic	Rating	Unit
$V_{CC}$	Power Supply ( $V_{EE} = GND$ )	7.0	Vdc
$T_A$	Operating Temperature Range	0 to +75	°C
$T_{stg}$	Storage Temperature Range - Plastic	-55 to +150	°C

Stresses exceeding those listed in the Maximum Ratings table may damage the device. If any of these limits are exceeded, device functionality should not be assumed, damage may occur and reliability may be affected.

# MC10H350

**Table 2. ELECTRICAL CHARACTERISTICS** ( $V_{CC} = 5.0\text{ V} \pm 5\%$ ) (Note 1)

Symbol	Characteristic	$T_A = 0^\circ\text{C to } 75^\circ\text{C}$		Unit
		Min	Max	
$I_{CC}$	Power Supply Current TTL ECL	– –	20 12	mA
$I_{IH}$ $I_{INH}$	Input Current High Pin 9 Others	– –	20 50	$\mu\text{A}$
$I_{IL}$ $I_{INL}$	Input Current Low Pin 9 Others	– –	–0.6 50	mA
$V_{IH}$	Input Voltage High Pin 9	2.0	–	Vdc
$V_{IL}$	Input Voltage Low Pin 9	–	0.8	Vdc
$V_{DIFF}$	Differential Input Voltage (Note 1) Pins 3–6, 11–14 (1)	350	–	mV
$V_{CM}$	Voltage Common Mode Pins 3–6, 11–14	2.8	$V_{CC}$	Vdc
$V_{OH}$	Output Voltage High $I_{OH} = 3.0\text{ mA}$	2.7	–	Vdc
$V_{OL}$	Output Voltage Low $I_{OL} = 20\text{ mA}$	–	0.5	Vdc
$I_{OS}$	Short Circuit Current $V_{OUT} = 0\text{ V}$	–60	–150	mA
$I_{OZH}$	Output Disable Current High $V_{OUT} = 2.7\text{ V}$	–	50	$\mu\text{A}$
$I_{OZL}$	Output Disable Current Low $V_{OUT} = 0.5\text{ V}$	–	–50	$\mu\text{A}$

\*Positive Emitter Coupled Logic

1. Common mode input voltage to pins 3–4, 5–6, 11–12, 13–14 must be between the values of 2.8 V and 5.0 V. This common mode input voltage range includes the differential input swing.
2. For single-ended use, apply 3.75 V ( $V_{BB}$ ) to either input depending on output polarity required. Signal level range to other input is 3.3 V to 4.2 V.
3. Any unused gates should have the inverting inputs tied to  $V_{CC}$  and the noninverting inputs tied to ground to prevent output glitching.

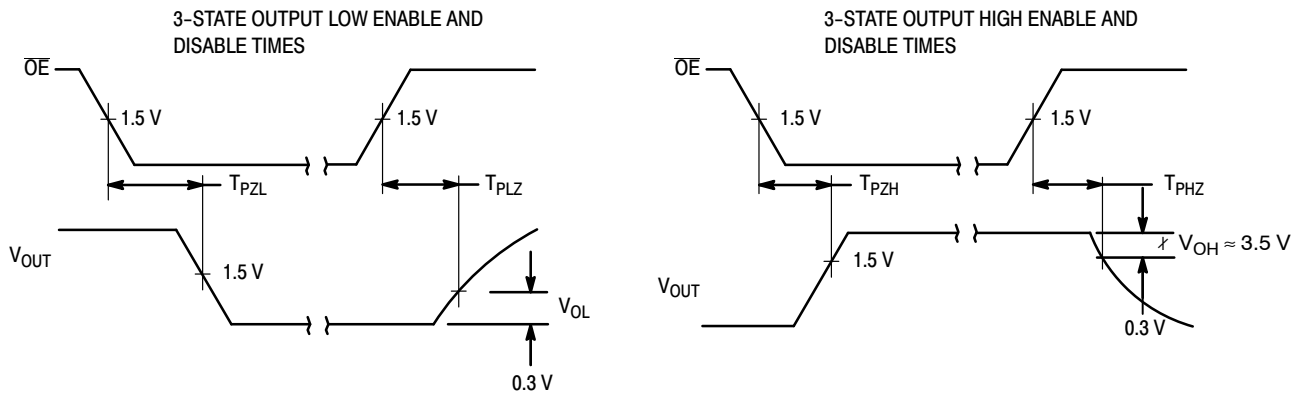
**Table 3. AC PARAMETERS** ( $C_L = 50\text{ pF}$ ) ( $V_{CC} = 5.0 \pm 5\%$ ) ( $T_A = 0^\circ\text{C to } 75^\circ\text{C}$ )

Symbol	Characteristic	$T_A = 0^\circ\text{C to } 75^\circ\text{C}$		Unit
		Min	Max	
$t_{pd}$	Propagation Delay Data (50% to 1.5 V)	1.5	5.0	ns
$t_r$	Rise Time (Note 1)	0.3	1.6	ns
$t_f$	Fall Time (Note 1)	0.3	1.6	ns
$t_{pdLZ}$ $t_{pdHZ}$	Output Disable Time	2.0 2.0	6.0 6.0	ns
$t_{pdZL}$ $t_{pdZH}$	Output Enable Time	2.0 2.0	8.0 8.0	ns

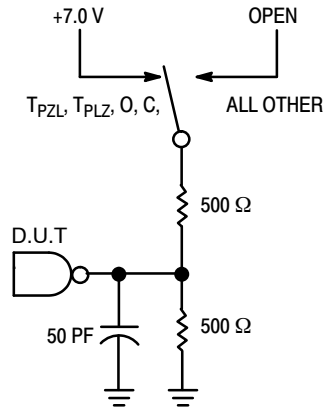
NOTE: Device will meet the specifications after thermal equilibrium has been established when mounted in a test socket or printed circuit board with maintained transverse airflow greater than 500 lfm. Electrical parameters are guaranteed only over the declared operating temperature range. Functional operation of the device exceeding these conditions is not implied. Device specification limit values are applied individually under normal operating conditions and not valid simultaneously.

1. 1.0 V to 2.0 V w/50 pF into 500  $\Omega$ .

# MC10H350



**Figure 4. 3-State Switching Waveforms**



\*INCLUDES JIG AND PROBE CAPACITANCE

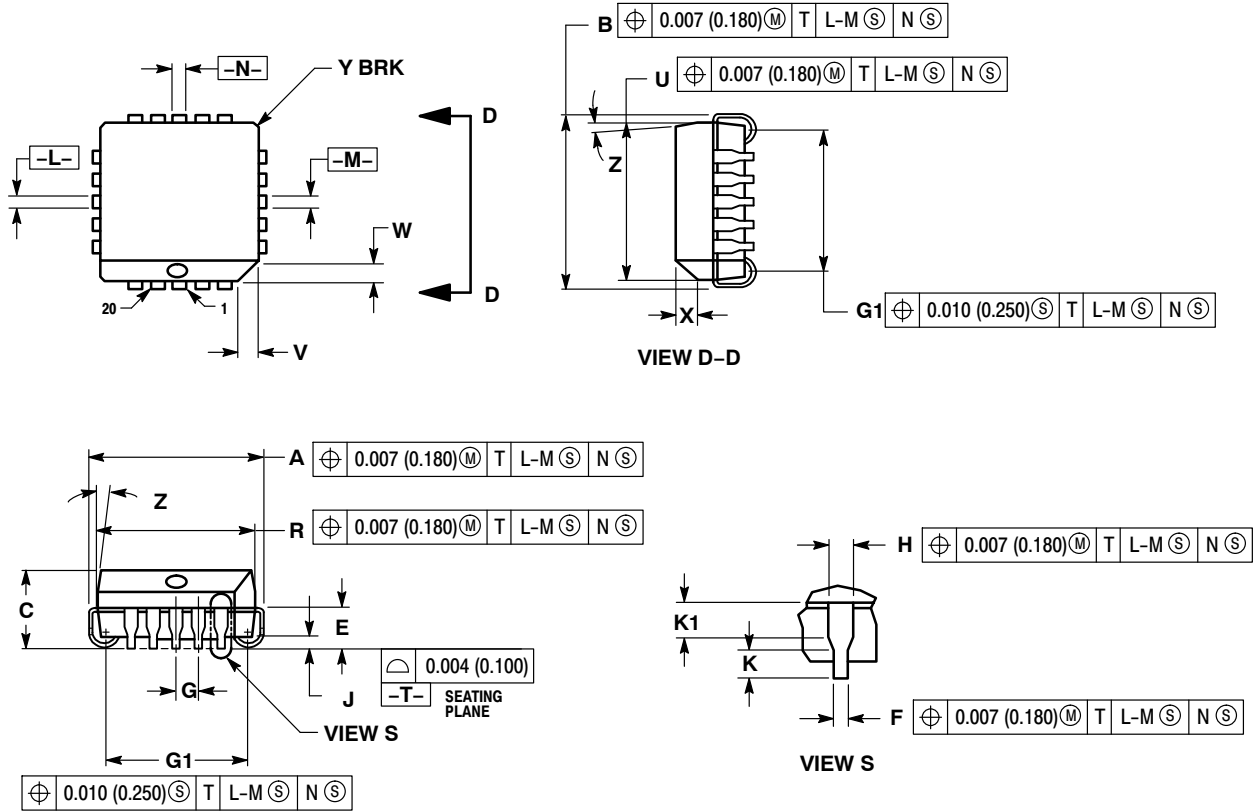
Application Note: Pin 9 is an  $\overline{OE}$  and the MC10H350 is disabled when  $\overline{OE}$  is at  $V_{IH}$  or higher.

**Figure 5. Test Load**

# MC10H350

## PACKAGE DIMENSIONS

20 LEAD PLLC  
FN SUFFIX  
CASE 775-02  
ISSUE F



**NOTES:**

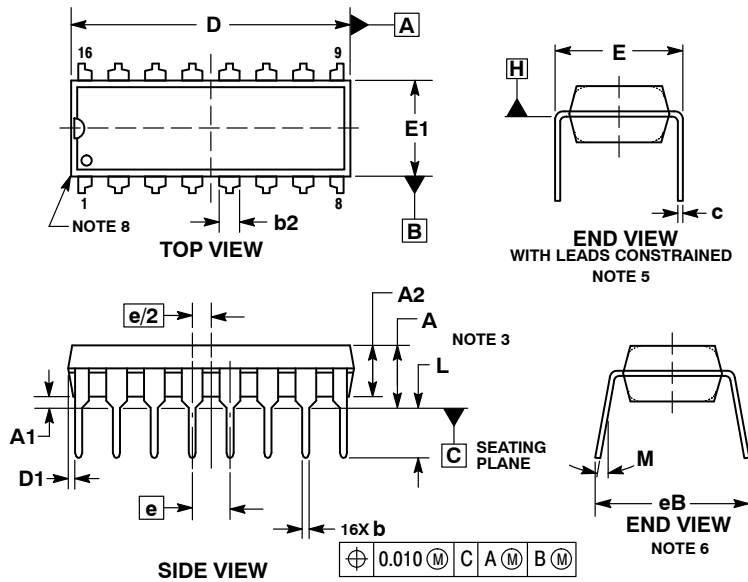
1. DIMENSIONS AND TOLERANCING PER ANSI Y14.5M, 1982.
2. DIMENSIONS IN INCHES.
3. DATUMS -L-, -M-, AND -N- DETERMINED WHERE TOP OF LEAD SHOULDER EXITS PLASTIC BODY AT MOLD PARTING LINE.
4. DIMENSION G1, TRUE POSITION TO BE MEASURED AT DATUM -T-, SEATING PLANE.
5. DIMENSIONS R AND U DO NOT INCLUDE MOLD FLASH. ALLOWABLE MOLD FLASH IS 0.010 (0.250) PER SIDE.
6. DIMENSIONS IN THE PACKAGE TOP MAY BE SMALLER THAN THE PACKAGE BOTTOM BY UP TO 0.012 (0.300). DIMENSIONS R AND U ARE DETERMINED AT THE OUTERMOST EXTREMES OF THE PLASTIC BODY EXCLUSIVE OF MOLD FLASH, TIE BAR BURRS, GATE BURRS AND INTERLEAD FLASH, BUT INCLUDING ANY MISMATCH BETWEEN THE TOP AND BOTTOM OF THE PLASTIC BODY.
7. DIMENSION H DOES NOT INCLUDE DAMBAR PROTRUSION OR INTRUSION. THE DAMBAR PROTRUSION(S) SHALL NOT CAUSE THE H DIMENSION TO BE GREATER THAN 0.037 (0.940). THE DAMBAR INTRUSION(S) SHALL NOT CAUSE THE H DIMENSION TO BE SMALLER THAN 0.025 (0.635).

DIM	INCHES		MILLIMETERS	
	MIN	MAX	MIN	MAX
A	0.385	0.395	9.78	10.03
B	0.385	0.395	9.78	10.03
C	0.165	0.180	4.20	4.57
E	0.090	0.110	2.29	2.79
F	0.013	0.021	0.33	0.53
G	0.050 BSC		1.27 BSC	
H	0.026	0.032	0.66	0.81
J	0.020	----	0.51	----
K	0.025	----	0.64	----
R	0.350	0.356	8.89	9.04
U	0.350	0.356	8.89	9.04
V	0.042	0.048	1.07	1.21
W	0.042	0.048	1.07	1.21
X	0.042	0.056	1.07	1.42
Y	----	0.020	----	0.50
Z	2°		10°	
G1	0.310	0.330	7.88	8.38
K1	0.040	----	1.02	----

# MC10H350

## PACKAGE DIMENSIONS

PDIP-16  
P SUFFIX  
CASE 648-08  
ISSUE V



### NOTES:

1. DIMENSIONING AND TOLERANCING PER ASME Y14.5M, 1994.
2. CONTROLLING DIMENSION: INCHES.
3. DIMENSIONS A, A1 AND L ARE MEASURED WITH THE PACKAGE SEATED IN JEDEC SEATING PLANE GAUGE GS-3.
4. DIMENSIONS D, D1 AND E1 DO NOT INCLUDE MOLD FLASH OR PROTRUSIONS. MOLD FLASH OR PROTRUSIONS ARE NOT TO EXCEED 0.10 INCH.
5. DIMENSION E IS MEASURED AT A POINT 0.015 BELOW DATUM PLANE H WITH THE LEADS CONSTRAINED PERPENDICULAR TO DATUM C.
6. DIMENSION eB IS MEASURED AT THE LEAD TIPS WITH THE LEADS UNCONSTRAINED.
7. DATUM PLANE H IS COINCIDENT WITH THE BOTTOM OF THE LEADS, WHERE THE LEADS EXIT THE BODY.
8. PACKAGE CONTOUR IS OPTIONAL (ROUNDED OR SQUARE CORNERS).

DIM	INCHES		MILLIMETERS	
	MIN	MAX	MIN	MAX
A	----	0.210	----	5.33
A1	0.015	----	0.38	----
A2	0.115	0.195	2.92	4.95
b	0.014	0.022	0.35	0.56
b2	0.060 TYP		1.52 TYP	
C	0.008	0.014	0.20	0.36
D	0.735	0.775	18.67	19.69
D1	0.005	----	0.13	----
E	0.300	0.325	7.62	8.26
E1	0.240	0.280	6.10	7.11
e	0.100 BSC		2.54 BSC	
eB	----	0.430	----	10.92
L	0.115	0.150	2.92	3.81
M	----	10°	----	10°

### STYLE 1:

- PIN 1. CATHODE
- CATHODE
- CATHODE
- CATHODE
- CATHODE
- CATHODE
- CATHODE
- CATHODE
- ANODE
- ANODE
- ANODE
- ANODE
- ANODE
- ANODE
- ANODE
- ANODE

### STYLE 2:

- PIN 1. COMMON DRAIN
- COMMON DRAIN
- COMMON DRAIN
- COMMON DRAIN
- COMMON DRAIN
- COMMON DRAIN
- COMMON DRAIN
- COMMON DRAIN
- GATE
- SOURCE
- GATE
- SOURCE
- GATE
- SOURCE
- GATE
- SOURCE

MECL is trademark of Semiconductor Components Industries, LLC (SCILLC) or its subsidiaries in the United States and/or other countries.

ON Semiconductor and are trademarks of Semiconductor Components Industries, LLC dba ON Semiconductor or its subsidiaries in the United States and/or other countries. ON Semiconductor owns the rights to a number of patents, trademarks, copyrights, trade secrets, and other intellectual property. A listing of ON Semiconductor's product/patent coverage may be accessed at [www.onsemi.com/site/pdf/Patent-Marking.pdf](http://www.onsemi.com/site/pdf/Patent-Marking.pdf). ON Semiconductor reserves the right to make changes without further notice to any products herein. ON Semiconductor makes no warranty, representation or guarantee regarding the suitability of its products for any particular purpose, nor does ON Semiconductor assume any liability arising out of the application or use of any product or circuit, and specifically disclaims any and all liability, including without limitation special, consequential or incidental damages. Buyer is responsible for its products and applications using ON Semiconductor products, including compliance with all laws, regulations and safety requirements or standards, regardless of any support or applications information provided by ON Semiconductor. "Typical" parameters which may be provided in ON Semiconductor data sheets and/or specifications can and do vary in different applications and actual performance may vary over time. All operating parameters, including "Typicals" must be validated for each customer application by customer's technical experts. ON Semiconductor does not convey any license under its patent rights nor the rights of others. ON Semiconductor products are not designed, intended, or authorized for use as a critical component in life support systems or any FDA Class 3 medical devices or medical devices with a same or similar classification in a foreign jurisdiction or any devices intended for implantation in the human body. Should Buyer purchase or use ON Semiconductor products for any such unintended or unauthorized application, Buyer shall indemnify and hold ON Semiconductor and its officers, employees, subsidiaries, affiliates, and distributors harmless against all claims, costs, damages, and expenses, and reasonable attorney fees arising out of, directly or indirectly, any claim of personal injury or death associated with such unintended or unauthorized use, even if such claim alleges that ON Semiconductor was negligent regarding the design or manufacture of the part. ON Semiconductor is an Equal Opportunity/Affirmative Action Employer. This literature is subject to all applicable copyright laws and is not for resale in any manner.

## PUBLICATION ORDERING INFORMATION

### LITERATURE FULFILLMENT:

Literature Distribution Center for ON Semiconductor  
19521 E. 32nd Pkwy, Aurora, Colorado 80011 USA  
Phone: 303-675-2175 or 800-344-3860 Toll Free USA/Canada  
Fax: 303-675-2176 or 800-344-3867 Toll Free USA/Canada  
Email: [orderlit@onsemi.com](mailto:orderlit@onsemi.com)

**N. American Technical Support:** 800-282-9855 Toll Free  
USA/Canada  
**Europe, Middle East and Africa Technical Support:**  
Phone: 421 33 790 2910  
**Japan Customer Focus Center**  
Phone: 81-3-5817-1050

**ON Semiconductor Website:** [www.onsemi.com](http://www.onsemi.com)

**Order Literature:** <http://www.onsemi.com/orderlit>

For additional information, please contact your local Sales Representative

## Looking for pricing, stock, or lifecycle information?

Click below to explore more details on WIN SOURCE:

- ⊖ [View MC10H350MEL on WIN SOURCE](#)
- ⊖ [ON Semiconductor Information](#)

## Optimize Your Supply Chain with WIN SOURCE Solutions

- ✓ Global Sourcing Solution
- ✓ Obsolete Management
- ✓ Cost Control Management
- ✓ Shortage Management
- ✓ Alternative Solution
- ✓ Excess Inventory Management