



**THE DATASHEET OF
MC10E143FNR2G**



MC10E143, MC100E143

5 V ECL 9-Bit Hold Register

Description

The MC10E/100E143 is a 9-bit holding register, designed with byte-parity applications in mind. The E143 holds current data or loads new data, with the nine inputs D0 – D8 accepting parallel input data.

The SEL (Select) input pin is used to switch between the two modes of operation – HOLD and LOAD. Input data is accepted by the registers a set-up time before the positive going edge of CLK1 or CLK2. A HIGH on the Master Reset pin (MR) asynchronously resets all the registers to zero.

The 100 Series contains temperature compensation.

Features

- 700 MHz Min. Operating Frequency
- 9-Bit for Byte-Parity Applications
- Asynchronous Master Reset
- Dual Clocks
- PECL Mode Operating Range:
 - ◆ $V_{CC} = 4.2\text{ V to } 5.7\text{ V}$ with $V_{EE} = 0\text{ V}$
- NECL Mode Operating Range:
 - ◆ $V_{CC} = 0\text{ V}$ with $V_{EE} = -4.2\text{ V to } -5.7\text{ V}$
- Internal Input 50 k Ω Pulldown Resistors
- ESD Protection:
 - ◆ Human Body Model; > 2 kV
 - ◆ Machine Model; > 200 V
- Meets or Exceeds JEDEC Standard EIA/JESD78 IC Latchup Test
- Moisture Sensitivity Level: 3 (Pb-Free)
 - ◆ For Additional Information, see Application Note [AND8003/D](#)
- Flammability Rating: UL 94 V-0 @ 0.125 in, Oxygen Index: 28 to 34
- Transistor Count = 484 devices
- These Devices are Pb-Free, Halogen Free and are RoHS Compliant



ON Semiconductor®

www.onsemi.com

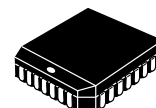

PLCC-28
FN SUFFIX
CASE 776-02

MARKING DIAGRAM*

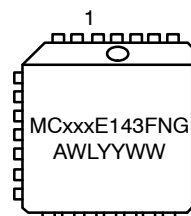

xxx = 10 or 100
A = Assembly Location
WL = Wafer Lot
YY = Year
WW = Work Week
G = Pb-Free Package

*For additional marking information, refer to Application Note [AND8002/D](#).

ORDERING INFORMATION

Device	Package	Shipping†
MC10E143FNR2G	PLCC-28 (Pb-Free)	500/Tape & Reel
MC100E143FNG	PLCC-28 (Pb-Free)	37 Units/Tube

†For information on tape and reel specifications, including part orientation and tape sizes, please refer to our Tape and Reel Packaging Specifications Brochure, [BRD8011/D](#).

MC10E143, MC100E143

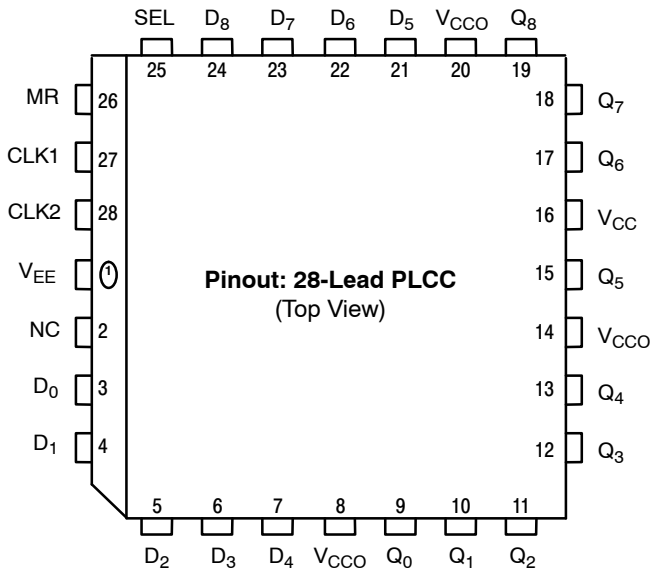

**Pinout: 28-Lead PLCC
(Top View)**

* All V_{CC} and V_{CCO} pins are tied together on the die.

Warning: All V_{CC}, V_{CCO}, and V_{EE} pins must be externally connected to Power Supply to guarantee proper operation.

Figure 1. 28-Lead Pinout

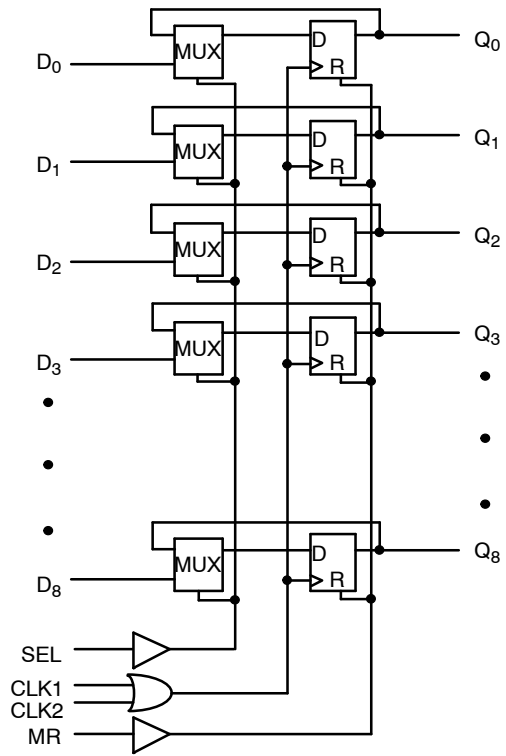

Figure 2. Logic Diagram

Table 1. PIN DESCRIPTION

PIN	FUNCTION
D ₀ – D ₈	ECL Parallel Data Inputs
SEL	ECL Mode Select Input
CLK1, CLK2	ECL Clock Inputs
MR	ECL Master Reset
Q ₀ – Q ₈	ECL Data Outputs
NC	No Connect
V _{CC} , V _{CCO}	Positive Supply*
V _{EE}	Negative Supply

*From V_{CC} pin to each V_{CCO} pin is an internal 100 Ω resistor.

Table 2. FUNCTIONS

SEL	Mode
L	Load
H	Hold

MC10E143, MC100E143

Table 3. MAXIMUM RATINGS

Symbol	Parameter	Condition 1	Condition 2	Rating	Unit
V _{CC}	PECL Mode Power Supply	V _{EE} = 0 V		8	V
V _{EE}	NECL Mode Power Supply	V _{CC} = 0 V		-8	V
V _I	PECL Mode Input Voltage NECL Mode Input Voltage	V _{EE} = 0 V V _{CC} = 0 V	V _I ≤ V _{CC} V _I ≥ V _{EE}	6 -6	V
I _{out}	Output Current	Continuous Surge		50 100	mA
T _A	Operating Temperature Range			0 to +85	°C
T _{stg}	Storage Temperature Range			-65 to +150	°C
θ _{JA}	Thermal Resistance (Junction-to-Ambient)	0 lfpm 500 lfpm	PLCC-28	63.5 43.5	°C/W
θ _{JC}	Thermal Resistance (Junction-to-Case)	Standard Board	PLCC-28	22 to 26	°C/W
V _{EE}	PECL Operating Range NECL Operating Range			4.2 to 5.7 -5.7 to -4.2	V
T _{sol}	Wave Solder (Pb-Free)			265	°C

Stresses exceeding those listed in the Maximum Ratings table may damage the device. If any of these limits are exceeded, device functionality should not be assumed, damage may occur and reliability may be affected.

Table 4. 10E SERIES PECL DC CHARACTERISTICS (V_{CCx} = 5.0 V; V_{EE} = 0.0 V (Note 1))

Symbol	Characteristic	0°C			25°C			85°C			Unit
		Min	Typ	Max	Min	Typ	Max	Min	Typ	Max	
I _{EE}	Power Supply Current		120	145		120	145		120	145	mA
V _{OH}	Output HIGH Voltage (Note 2)	3980	4070	4160	4020	4105	4190	4090	4185	4280	mV
V _{OL}	Output LOW Voltage (Note 2)	3050	3210	3370	3050	3210	3370	3050	3227	3405	mV
V _{IH}	Input HIGH Voltage	3830	3995	4160	3870	4030	4190	3940	4110	4280	mV
V _{IL}	Input LOW Voltage	3050	3285	3520	3050	3285	3520	3050	3302	3555	mV
I _{IH}	Input HIGH Current			150			150			150	μA
I _{IL}	Input LOW Current	0.5	0.3		0.5	0.25		0.3	0.2		μA

NOTE: Device will meet the specifications after thermal equilibrium has been established when mounted in a test socket or printed circuit board with maintained transverse airflow greater than 500 lfpm. Electrical parameters are guaranteed only over the declared operating temperature range. Functional operation of the device exceeding these conditions is not implied. Device specification limit values are applied individually under normal operating conditions and not valid simultaneously.

1. Input and output parameters vary 1:1 with V_{CC}. V_{EE} can vary -0.46 V / +0.06 V.
2. Outputs are terminated through a 50 Ω resistor to V_{CC} - 2.0 V.

MC10E143, MC100E143

Table 5. 10E SERIES NECL DC CHARACTERISTICS ($V_{CCx} = 0.0\text{ V}$; $V_{EE} = -5.0\text{ V}$ (Note 1))

Symbol	Characteristic	0°C			25°C			85°C			Unit
		Min	Typ	Max	Min	Typ	Max	Min	Typ	Max	
I_{EE}	Power Supply Current		120	145		120	145		120	145	mA
V_{OH}	Output HIGH Voltage (Note 2)	-1020	-930	-840	-980	-895	-810	-910	-815	-720	mV
V_{OL}	Output LOW Voltage (Note 2)	-1950	-1790	-1630	-1950	-1790	-1630	-1950	-1773	-1595	mV
V_{IH}	Input HIGH Voltage	-1170	-1005	-840	-1130	-970	-810	-1060	-890	-720	mV
V_{IL}	Input LOW Voltage	-1950	-1715	-1480	-1950	-1715	-1480	-1950	-1698	-1445	mV
I_{IH}	Input HIGH Current			150			150			150	μA
I_{IL}	Input LOW Current	0.5	0.3		0.5	0.065		0.3	0.2		μA

NOTE: Device will meet the specifications after thermal equilibrium has been established when mounted in a test socket or printed circuit board with maintained transverse airflow greater than 500 lfm. Electrical parameters are guaranteed only over the declared operating temperature range. Functional operation of the device exceeding these conditions is not implied. Device specification limit values are applied individually under normal operating conditions and not valid simultaneously.

1. Input and output parameters vary 1:1 with V_{CC} . V_{EE} can vary $-0.46\text{ V} / +0.06\text{ V}$.
2. Outputs are terminated through a $50\ \Omega$ resistor to $V_{CC} - 2.0\text{ V}$.

Table 6. 100E SERIES PECL DC CHARACTERISTICS ($V_{CCx} = 5.0\text{ V}$; $V_{EE} = 0.0\text{ V}$ (Note 1))

Symbol	Characteristic	0°C			25°C			85°C			Unit
		Min	Typ	Max	Min	Typ	Max	Min	Typ	Max	
I_{EE}	Power Supply Current		120	145		120	145		138	165	mA
V_{OH}	Output HIGH Voltage (Note 2)	3975	4050	4120	3975	4050	4120	3975	4050	4120	mV
V_{OL}	Output LOW Voltage (Note 2)	3190	3295	3380	3190	3255	3380	3190	3260	3380	mV
V_{IH}	Input HIGH Voltage	3835	3975	4120	3835	3975	4120	3835	3975	4120	mV
V_{IL}	Input LOW Voltage	3190	3355	3525	3190	3355	3525	3190	3355	3525	mV
I_{IH}	Input HIGH Current			150			150			150	μA
I_{IL}	Input LOW Current	0.5	0.3		0.5	0.25		0.5	0.2		μA

NOTE: Device will meet the specifications after thermal equilibrium has been established when mounted in a test socket or printed circuit board with maintained transverse airflow greater than 500 lfm. Electrical parameters are guaranteed only over the declared operating temperature range. Functional operation of the device exceeding these conditions is not implied. Device specification limit values are applied individually under normal operating conditions and not valid simultaneously.

1. Input and output parameters vary 1:1 with V_{CC} . V_{EE} can vary $-0.46\text{ V} / +0.8\text{ V}$.
2. Outputs are terminated through a $50\ \Omega$ resistor to $V_{CC} - 2.0\text{ V}$.

Table 7. 100E SERIES NECL DC CHARACTERISTICS ($V_{CCx} = 0.0\text{ V}$; $V_{EE} = -5.0\text{ V}$ (Note 1))

Symbol	Characteristic	0°C			25°C			85°C			Unit
		Min	Typ	Max	Min	Typ	Max	Min	Typ	Max	
I_{EE}	Power Supply Current		120	145		120	145		138	165	mA
V_{OH}	Output HIGH Voltage (Note 2)	-1025	-950	-880	-1025	-950	-880	-1025	-950	-880	mV
V_{OL}	Output LOW Voltage (Note 2)	-1810	-1705	-1620	-1810	-1745	-1620	-1810	-1740	-1620	mV
V_{IH}	Input HIGH Voltage	-1165	-1025	-880	-1165	-1025	-880	-1165	-1025	-880	mV
V_{IL}	Input LOW Voltage	-1810	-1645	-1475	-1810	-1645	-1475	-1810	-1645	-1475	mV
I_{IH}	Input HIGH Current			150			150			150	μA
I_{IL}	Input LOW Current	0.5	0.3		0.5	0.25		0.5	0.2		μA

NOTE: Device will meet the specifications after thermal equilibrium has been established when mounted in a test socket or printed circuit board with maintained transverse airflow greater than 500 lfm. Electrical parameters are guaranteed only over the declared operating temperature range. Functional operation of the device exceeding these conditions is not implied. Device specification limit values are applied individually under normal operating conditions and not valid simultaneously.

1. Input and output parameters vary 1:1 with V_{CC} . V_{EE} can vary $-0.46\text{ V} / +0.8\text{ V}$.
2. Outputs are terminated through a $50\ \Omega$ resistor to $V_{CC} - 2.0\text{ V}$.

MC10E143, MC100E143

Table 8. AC CHARACTERISTICS ($V_{CCx} = 5.0\text{ V}$; $V_{EE} = 0.0\text{ V}$ or $V_{CCx} = 0.0\text{ V}$; $V_{EE} = -5.0\text{ V}$ (Note 1))

Symbol	Characteristic	0°C			25°C			85°C			Unit
		Min	Typ	Max	Min	Typ	Max	Min	Typ	Max	
f_{SHIFT}	Max. Shift Frequency	700	900		700	900		700	900		MHz
t_{PLH} t_{PHL}	Propagation Delay To Output Clk MR	600 600	800 800	1000 1000	600 600	800 800	1000 1000	600 600	800 800	1000 1000	ps
t_s	Setup Time D SEL	50 300	-100 150		50 300	-100 150		50 300	-100 150		ps
t_h	Hold Time D SEL	300 75	100 -150		300 75	100 -150		300 75	100 -150		ps
t_{RR}	Reset Recovery Time	900	700		900	700		900	700		ps
t_{PW}	Minimum Pulse Width Clk, MR	400			400			400			ps
t_{SKEW}	Within-Device Skew (Note 2)		75			75			75		ps
t_{JITTER}	Random Clock Jitter (RMS)		< 1			< 1			< 1		ps
T_r t_f	Rise/Fall Times (20 - 80%)	300	525	800	300	525	800	300	525	800	ps

NOTE: Device will meet the specifications after thermal equilibrium has been established when mounted in a test socket or printed circuit board with maintained transverse airflow greater than 500 lpm. Electrical parameters are guaranteed only over the declared operating temperature range. Functional operation of the device exceeding these conditions is not implied. Device specification limit values are applied individually under normal operating conditions and not valid simultaneously.

- 10 Series: V_{EE} can vary $-0.46\text{ V} / +0.06\text{ V}$.
100 Series: V_{EE} can vary $-0.46\text{ V} / +0.8\text{ V}$.
- Within-device skew is defined as identical transitions on similar paths through a device.

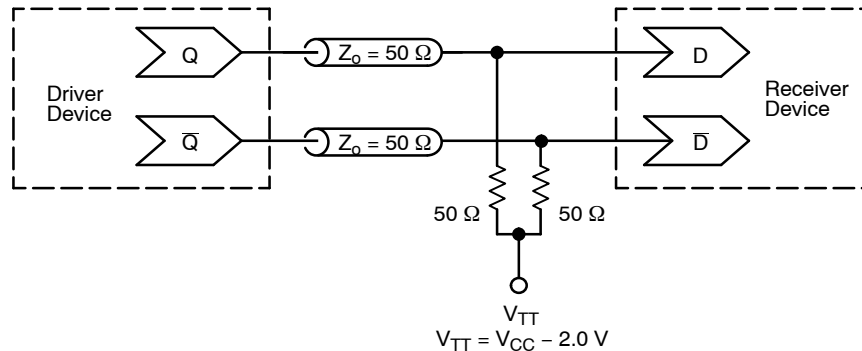

Figure 3. Typical Termination for Output Driver and Device Evaluation
(See Application Note [AND8020/D](#) – Termination of ECL Logic Devices.)

Resource Reference of Application Notes

- AN1405/D** – ECL Clock Distribution Techniques
- AN1406/D** – Designing with PECL (ECL at +5.0 V)
- AN1503/D** – ECLinPS™ I/O SPICE Modeling Kit
- AN1504/D** – Metastability and the ECLinPS Family
- AN1568/D** – Interfacing Between LVDS and ECL
- AN1672/D** – The ECL Translator Guide
- AND8001/D** – Odd Number Counters Design
- AND8002/D** – Marking and Date Codes
- AND8020/D** – Termination of ECL Logic Devices
- AND8066/D** – Interfacing with ECLinPS
- AND8090/D** – AC Characteristics of ECL Devices

MC10E143, MC100E143

PACKAGE DIMENSIONS

28 LEAD PLLC
CASE 776-02
ISSUE F

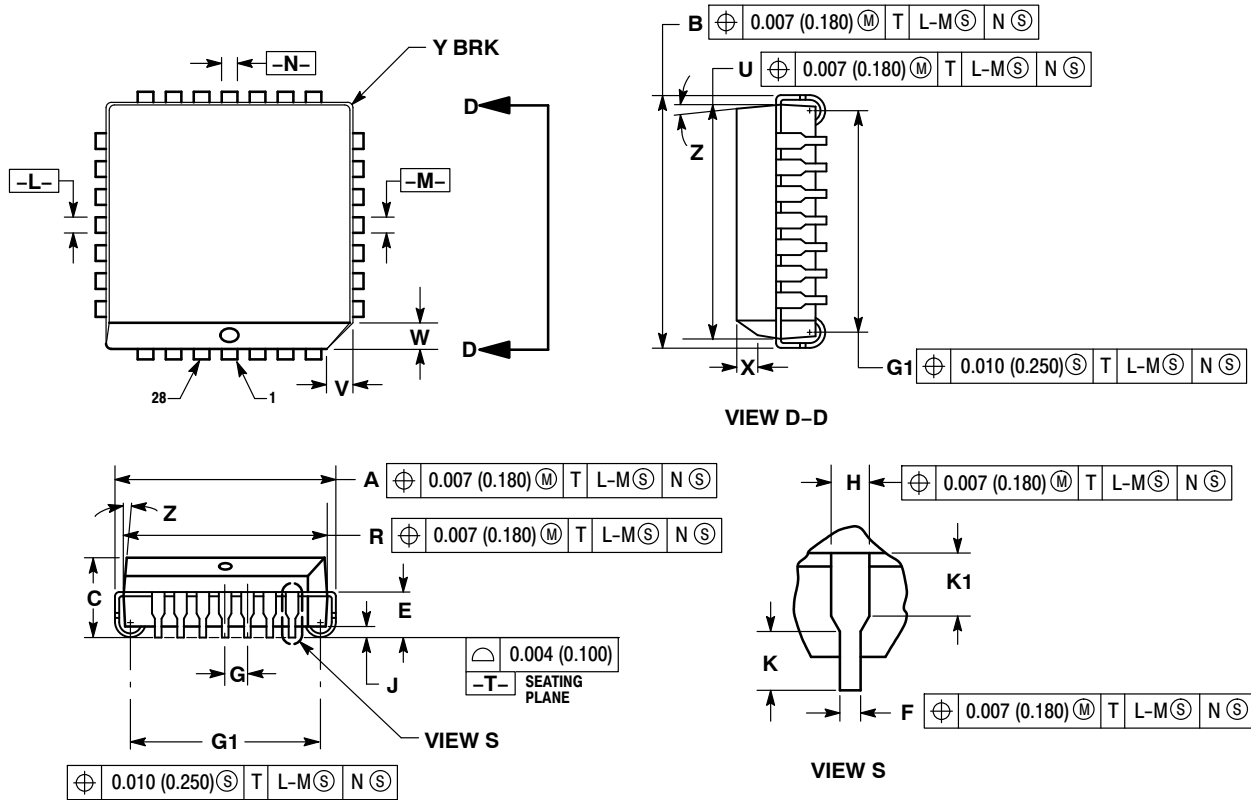

NOTES:

- DATUMS -L-, -M-, AND -N- DETERMINED WHERE TOP OF LEAD SHOULDER EXITS PLASTIC BODY AT MOLD PARTING LINE.
- DIMENSION G1, TRUE POSITION TO BE MEASURED AT DATUM -T-, SEATING PLANE.
- DIMENSIONS R AND U DO NOT INCLUDE MOLD FLASH. ALLOWABLE MOLD FLASH IS 0.010 (0.250) PER SIDE.
- DIMENSIONING AND TOLERANCING PER ANSI Y14.5M, 1982.
- CONTROLLING DIMENSION: INCH.
- THE PACKAGE TOP MAY BE SMALLER THAN THE PACKAGE BOTTOM BY UP TO 0.012 (0.300). DIMENSIONS R AND U ARE DETERMINED AT THE OUTERMOST EXTREMES OF THE PLASTIC BODY EXCLUSIVE OF MOLD FLASH, TIE BAR BURRS, GATE BURRS AND INTERLEAD FLASH, BUT INCLUDING ANY MISMATCH BETWEEN THE TOP AND BOTTOM OF THE PLASTIC BODY.
- DIMENSION H DOES NOT INCLUDE DAMBAR PROTRUSION OR INTRUSION. THE DAMBAR PROTRUSION(S) SHALL NOT CAUSE THE H DIMENSION TO BE GREATER THAN 0.037 (0.940). THE DAMBAR INTRUSION(S) SHALL NOT CAUSE THE H DIMENSION TO BE SMALLER THAN 0.025 (0.635).

DIM	INCHES		MILLIMETERS	
	MIN	MAX	MIN	MAX
A	0.485	0.495	12.32	12.57
B	0.485	0.495	12.32	12.57
C	0.165	0.180	4.20	4.57
E	0.090	0.110	2.29	2.79
F	0.013	0.021	0.33	0.53
G	0.050 BSC		1.27 BSC	
H	0.026	0.032	0.66	0.81
J	0.020	---	0.51	---
K	0.025	---	0.64	---
R	0.450	0.456	11.43	11.58
U	0.450	0.456	11.43	11.58
V	0.042	0.048	1.07	1.21
W	0.042	0.048	1.07	1.21
X	0.042	0.056	1.07	1.42
Y	---	0.020	---	0.50
Z	2°	10°	2°	10°
G1	0.410	0.430	10.42	10.92
K1	0.040	---	1.02	---

MC10E143, MC100E143

ECLinPS is a registered trademark of Semiconductor Components Industries, LLC (SCILLC) or its subsidiaries in the United States and/or other countries.

ON Semiconductor and  are trademarks of Semiconductor Components Industries, LLC dba ON Semiconductor or its subsidiaries in the United States and/or other countries. ON Semiconductor owns the rights to a number of patents, trademarks, copyrights, trade secrets, and other intellectual property. A listing of ON Semiconductor's product/patent coverage may be accessed at www.onsemi.com/site/pdf/Patent-Marking.pdf. ON Semiconductor reserves the right to make changes without further notice to any products herein. ON Semiconductor makes no warranty, representation or guarantee regarding the suitability of its products for any particular purpose, nor does ON Semiconductor assume any liability arising out of the application or use of any product or circuit, and specifically disclaims any and all liability, including without limitation special, consequential or incidental damages. Buyer is responsible for its products and applications using ON Semiconductor products, including compliance with all laws, regulations and safety requirements or standards, regardless of any support or applications information provided by ON Semiconductor. "Typical" parameters which may be provided in ON Semiconductor data sheets and/or specifications can and do vary in different applications and actual performance may vary over time. All operating parameters, including "Typicals" must be validated for each customer application by customer's technical experts. ON Semiconductor does not convey any license under its patent rights nor the rights of others. ON Semiconductor products are not designed, intended, or authorized for use as a critical component in life support systems or any FDA Class 3 medical devices or medical devices with a same or similar classification in a foreign jurisdiction or any devices intended for implantation in the human body. Should Buyer purchase or use ON Semiconductor products for any such unintended or unauthorized application, Buyer shall indemnify and hold ON Semiconductor and its officers, employees, subsidiaries, affiliates, and distributors harmless against all claims, costs, damages, and expenses, and reasonable attorney fees arising out of, directly or indirectly, any claim of personal injury or death associated with such unintended or unauthorized use, even if such claim alleges that ON Semiconductor was negligent regarding the design or manufacture of the part. ON Semiconductor is an Equal Opportunity/Affirmative Action Employer. This literature is subject to all applicable copyright laws and is not for resale in any manner.

PUBLICATION ORDERING INFORMATION

LITERATURE FULFILLMENT:

Literature Distribution Center for ON Semiconductor
19521 E. 32nd Pkwy, Aurora, Colorado 80011 USA
Phone: 303-675-2175 or 800-344-3860 Toll Free USA/Canada
Fax: 303-675-2176 or 800-344-3867 Toll Free USA/Canada
Email: orderlit@onsemi.com

N. American Technical Support: 800-282-9855 Toll Free
USA/Canada
Europe, Middle East and Africa Technical Support:
Phone: 421 33 790 2910
Japan Customer Focus Center
Phone: 81-3-5817-1050

ON Semiconductor Website: www.onsemi.com
Order Literature: <http://www.onsemi.com/orderlit>
For additional information, please contact your local
Sales Representative

Looking for pricing, stock, or lifecycle information?

Click below to explore more details on WIN SOURCE:

 [View MC10E143FNR2G on WIN SOURCE](#)

 [ON Semiconductor](#) Information

Optimize Your Supply Chain with WIN SOURCE Solutions

-  Global Sourcing Solution
-  Obsolete Management
-  Cost Control Management
-  Shortage Management
-  Alternative Solution
-  Excess Inventory Management