



**THE DATASHEET OF  
MC10E131FNR2G**



# MC10E131, MC100E131

## 5 V ECL 4-Bit D Flip-Flop

### Description

The MC10E/100E131 is a quad master-slave D-type flip-flop with differential outputs. Each flip-flop may be clocked separately by holding Common Clock ( $C_C$ ) LOW and using the Clock Enable ( $\overline{CE}$ ) inputs for clocking. Common clocking is achieved by holding the  $\overline{CE}$  inputs LOW and using  $C_C$  to clock all four flip-flops. In this case, the  $\overline{CE}$  inputs perform the function of controlling the common clock, to each flip-flop.

Individual asynchronous resets are provided (R). Asynchronous set controls (S) are ganged together in pairs, with the pairing chosen to reflect physical chip symmetry.

Data enters the master when both  $C_C$  and  $\overline{CE}$  are LOW, and transfers to the slave when either  $C_C$  or  $\overline{CE}$  (or both) go HIGH.

The 100 Series contains temperature compensation.

### Features

- 1100 MHz Min. Toggle Frequency
- Differential Outputs
- Individual and Common Clocks
- Individual Resets (asynchronous)
- Paired Sets (asynchronous)
- PECL Mode Operating Range:
  - ♦  $V_{CC} = 4.2\text{ V to }5.7\text{ V}$  with  $V_{EE} = 0\text{ V}$
- NECL Mode Operating Range:
  - ♦  $V_{CC} = 0\text{ V}$  with  $V_{EE} = -4.2\text{ V to }-5.7\text{ V}$
- Metastability Time Constant is 200 ps.
- Internal Input 50 k $\Omega$  Pulldown Resistors
- ESD Protection:
  - ♦ Human Body Model; > 2 kV
  - ♦ Machine Model; > 200 V
- Meets or Exceeds JEDEC Spec EIA/JESD78 IC Latchup Test
- Moisture Sensitivity Level: 3 (Pb-Free)
  - ♦ For Additional Information, see Application Note [AND8003/D](#)
- Flammability Rating:UL 94 V-0 @ 0.125 in, Oxygen Index: 28 to 34
- Transistor Count = 240 devices
- These Devices are Pb-Free, Halogen Free and are RoHS Compliant



ON Semiconductor®

[www.onsemi.com](http://www.onsemi.com)

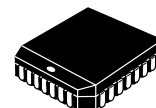

PLCC-28  
FN SUFFIX  
CASE 776-02

### MARKING DIAGRAM\*

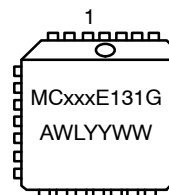

xxx = 10 or 100  
A = Assembly Location  
WL = Wafer Lot  
YY = Year  
WW = Work Week  
G = Pb-Free Package

\*For additional marking information, refer to Application Note [AND8002/D](#).

### ORDERING INFORMATION

Device	Package	Shipping†
MC10E131FNG	PLCC-28 (Pb-Free)	37 Units/Tube
MC10E131FNR2G	PLCC-28 (Pb-Free)	500/Tape & Reel
MC100E131FNG	PLCC-28 (Pb-Free)	37 Units/Tube
MC100E131FNR2G	PLCC-28 (Pb-Free)	500/Tape & Reel

†For information on tape and reel specifications, including part orientation and tape sizes, please refer to our Tape and Reel Packaging Specifications Brochure, [BRD8011/D](#).

# MC10E131, MC100E131

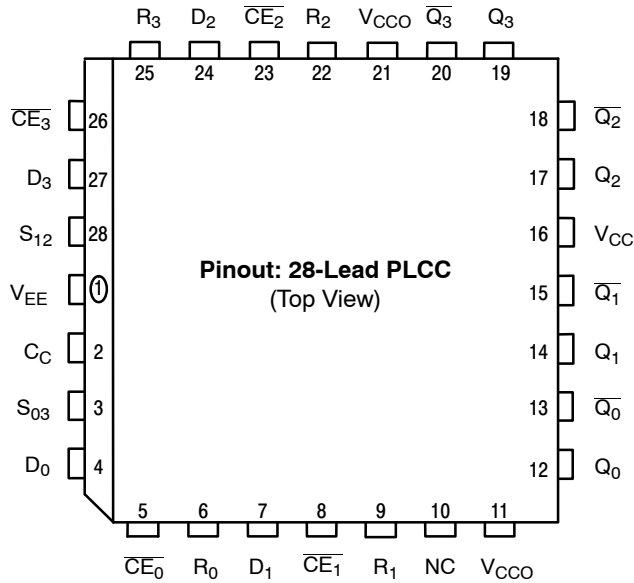

\* All  $V_{CC}$  and  $V_{CCO}$  pins are tied together on the die.

Warning: All  $V_{CC}$ ,  $V_{CCO}$ , and  $V_{EE}$  pins must be externally connected to Power Supply to guarantee proper operation.

**Figure 1. Pinout Diagram**

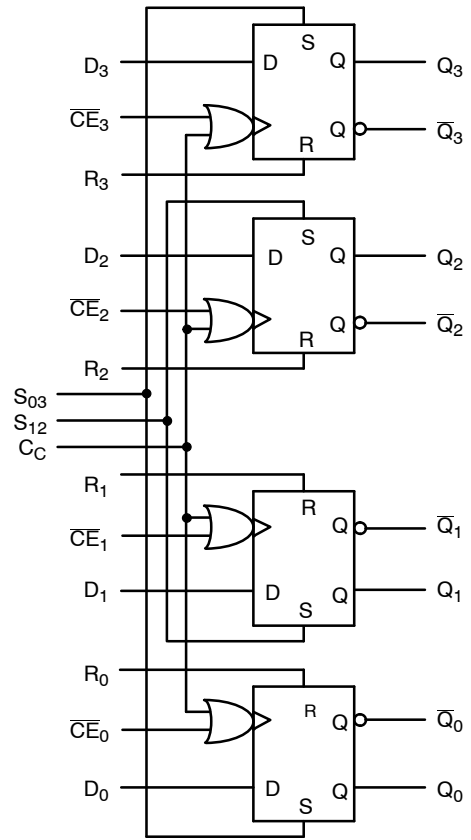

**Figure 2. Logic Diagram**

**Table 1. PIN DESCRIPTION**

PIN	FUNCTION
$D_0 - D_3$	ECL Data Inputs
$\overline{CE}_0 - \overline{CE}_3$	ECL Clock Enables (Individual)
$R_0 - R_3$	ECL Resets
$C_C$	ECL Common Clock
$S_{03}, S_{12}$	ECL Sets (paired)
$Q_0 - Q_3, \overline{Q}_0 - \overline{Q}_3$	ECL Differential Outputs
$V_{CC}, V_{CCO}$	Positive Supply
$V_{EE}$	Negative Supply
NC	No Connect

# MC10E131, MC100E131

**Table 2. MAXIMUM RATINGS**

Symbol	Parameter	Condition 1	Condition 2	Rating	Unit
V <sub>CC</sub>	PECL Mode Power Supply	V <sub>EE</sub> = 0 V		8	V
V <sub>EE</sub>	NECL Mode Power Supply	V <sub>CC</sub> = 0 V		-8	V
V <sub>I</sub>	PECL Mode Input Voltage NECL Mode Input Voltage	V <sub>EE</sub> = 0 V V <sub>CC</sub> = 0 V	V <sub>I</sub> ≤ V <sub>CC</sub> V <sub>I</sub> ≥ V <sub>EE</sub>	6 -6	V
I <sub>out</sub>	Output Current	Continuous Surge		50 100	mA
T <sub>A</sub>	Operating Temperature Range			0 to +85	°C
T <sub>stg</sub>	Storage Temperature Range			-65 to +150	°C
θ <sub>JA</sub>	Thermal Resistance (Junction-to-Ambient)	0 lfp 500 lfp	PLCC-28	63.5 43.5	°C/W
θ <sub>JC</sub>	Thermal Resistance (Junction-to-Case)	Standard Board	PLCC-28	22 to 26	°C/W
T <sub>sol</sub>	Wave Solder (Pb-Free)			265	°C

Stresses exceeding those listed in the Maximum Ratings table may damage the device. If any of these limits are exceeded, device functionality should not be assumed, damage may occur and reliability may be affected.

**Table 3. 10E SERIES PECL DC CHARACTERISTICS** (V<sub>CCx</sub> = 5.0 V; V<sub>EE</sub> = 0.0 V (Note 1))

Symbol	Characteristic	-40°C			0°C			25°C			85°C			Unit
		Min	Typ	Max	Min	Typ	Max	Min	Typ	Max	Min	Typ	Max	
I <sub>EE</sub>	Power Supply Current		58	70		58	70		58	70		58	70	mA
V <sub>OH</sub>	Output HIGH Voltage (Note 2)				3980	4070	4160	4020	4105	4190	4090	4185	4280	mV
V <sub>OL</sub>	Output LOW Voltage (Note 2)				3050	3210	3370	3050	3210	3370	3050	3227	3405	mV
V <sub>IH</sub>	Input HIGH Voltage				3830	3995	4160	3870	4030	4190	3940	4110	4280	mV
V <sub>IL</sub>	Input LOW Voltage				3050	3285	3520	3050	3285	3520	3050	3302	3555	mV
I <sub>IH</sub>	Input HIGH Current C S R, CE D			350 450 300 150			350 450 300 150			350 450 300 150			350 450 300 150	μA
I <sub>IL</sub>	Input LOW Current				0.5	0.3		0.5	0.25		0.3	0.2		μA

NOTE: Device will meet the specifications after thermal equilibrium has been established when mounted in a test socket or printed circuit board with maintained transverse airflow greater than 500 lfp. Electrical parameters are guaranteed only over the declared operating temperature range. Functional operation of the device exceeding these conditions is not implied. Device specification limit values are applied individually under normal operating conditions and not valid simultaneously.

1. Input and output parameters vary 1:1 with V<sub>CC</sub>. V<sub>EE</sub> can vary -0.46 V / +0.06 V.
2. Outputs are terminated through a 50 Ω resistor to V<sub>CC</sub> - 2.0 V.

# MC10E131, MC100E131

**Table 4. 10E SERIES NECL DC CHARACTERISTICS** ( $V_{CCx} = 0.0\text{ V}$ ;  $V_{EE} = -5.0\text{ V}$  (Note 1))

Symbol	Characteristic	-40°C			0°C			25°C			85°C			Unit
		Min	Typ	Max	Min	Typ	Max	Min	Typ	Max	Min	Typ	Max	
$I_{EE}$	Power Supply Current		58	70		58	70		58	70		58	70	mA
$V_{OH}$	Output HIGH Voltage (Note 2)				-1020	-930	-840	-980	-895	-810	-910	-815	-720	mV
$V_{OL}$	Output LOW Voltage (Note 2)				-1950	-1790	-1630	-1950	-1790	-1630	-1950	-1773	-1595	mV
$V_{IH}$	Input HIGH Voltage				-1170	-1005	-840	-1130	-970	-810	-1060	-890	-720	mV
$V_{IL}$	Input LOW Voltage				-1950	-1715	-1480	-1950	-1715	-1480	-1950	-1698	-1445	mV
$I_{IH}$	Input HIGH Current C S R, $\overline{CE}$ D			350 450 300 150			350 450 300 150			350 450 300 150			350 450 300 150	$\mu\text{A}$
$I_{IL}$	Input LOW Current				0.5	0.3		0.5	0.065		0.3	0.2		$\mu\text{A}$

NOTE: Device will meet the specifications after thermal equilibrium has been established when mounted in a test socket or printed circuit board with maintained transverse airflow greater than 500 lpm. Electrical parameters are guaranteed only over the declared operating temperature range. Functional operation of the device exceeding these conditions is not implied. Device specification limit values are applied individually under normal operating conditions and not valid simultaneously.

1. Input and output parameters vary 1:1 with  $V_{CC}$ .  $V_{EE}$  can vary  $-0.46\text{ V} / +0.06\text{ V}$ .
2. Outputs are terminated through a  $50\ \Omega$  resistor to  $V_{CC} - 2.0\text{ V}$ .

**Table 5. 100E SERIES PECL DC CHARACTERISTICS** ( $V_{CCx} = 5.0\text{ V}$ ;  $V_{EE} = 0.0\text{ V}$  (Note 1))

Symbol	Characteristic	-40°C			0°C			25°C			85°C			Unit
		Min	Typ	Max	Min	Typ	Max	Min	Typ	Max	Min	Typ	Max	
$I_{EE}$	Power Supply Current		58	70		58	70		58	70		67	81	mA
$V_{OH}$	Output HIGH Voltage (Note 2)				3975	4050	4120	3975	4050	4120	3975	4050	4120	mV
$V_{OL}$	Output LOW Voltage (Note 2)				3190	3295	3380	3190	3255	3380	3190	3260	3380	mV
$V_{IH}$	Input HIGH Voltage		3975		3835	3975	4120	3835	3975	4120	3835	3975	4120	mV
$V_{IL}$	Input LOW Voltage		3355		3190	3355	3525	3190	3355	3525	3190	3355	3525	mV
$I_{IH}$	Input HIGH Current C S R, $\overline{CE}$ D			350 450 300 150			350 450 300 150			350 450 300 150			350 450 300 150	$\mu\text{A}$
$I_{IL}$	Input LOW Current				0.5	0.3		0.5	0.25		0.5	0.2		$\mu\text{A}$

NOTE: Device will meet the specifications after thermal equilibrium has been established when mounted in a test socket or printed circuit board with maintained transverse airflow greater than 500 lpm. Electrical parameters are guaranteed only over the declared operating temperature range. Functional operation of the device exceeding these conditions is not implied. Device specification limit values are applied individually under normal operating conditions and not valid simultaneously.

1. Input and output parameters vary 1:1 with  $V_{CC}$ .  $V_{EE}$  can vary  $-0.46\text{ V} / +0.8\text{ V}$ .
2. Outputs are terminated through a  $50\ \Omega$  resistor to  $V_{CC} - 2.0\text{ V}$ .

# MC10E131, MC100E131

**Table 6. 100E SERIES NECL DC CHARACTERISTICS** ( $V_{CCx} = 0.0\text{ V}$ ;  $V_{EE} = -5.0\text{ V}$  (Note 1))

Symbol	Characteristic	-40°C			0°C			25°C			85°C			Unit
		Min	Typ	Max	Min	Typ	Max	Min	Typ	Max	Min	Typ	Max	
$I_{EE}$	Power Supply Current		58	70		58	70		58	70		67	81	mA
$V_{OH}$	Output HIGH Voltage (Note 2)				-1025	-950	-880	-1025	-950	-880	-1025	-950	-880	mV
$V_{OL}$	Output LOW Voltage (Note 2)				-1810	-1705	-1620	-1810	-1745	-1620	-1810	-1740	-1620	mV
$V_{IH}$	Input HIGH Voltage		-1025		-1165	-1025	-880	-1165	-1025	-880	-1165	-1025	-880	mV
$V_{IL}$	Input LOW Voltage		-1645		-1810	-1645	-1475	-1810	-1645	-1475	-1810	-1645	-1475	mV
$I_{IH}$	Input HIGH Current C <sub>C</sub> S R, $\overline{CE}$ D			350 450 300 150			350 450 300 150			350 450 300 150			350 450 300 150	$\mu\text{A}$
$I_{IL}$	Input LOW Current				0.5	0.3		0.5	0.25		0.5	0.2		$\mu\text{A}$

NOTE: Device will meet the specifications after thermal equilibrium has been established when mounted in a test socket or printed circuit board with maintained transverse airflow greater than 500 lfm. Electrical parameters are guaranteed only over the declared operating temperature range. Functional operation of the device exceeding these conditions is not implied. Device specification limit values are applied individually under normal operating conditions and not valid simultaneously.

1. Input and output parameters vary 1:1 with  $V_{CC}$ .  $V_{EE}$  can vary  $-0.46\text{ V} / +0.8\text{ V}$ .
2. Outputs are terminated through a  $50\ \Omega$  resistor to  $V_{CC} - 2.0\text{ V}$ .

**Table 7. AC CHARACTERISTICS** ( $V_{CCx} = 5.0\text{ V}$ ;  $V_{EE} = 0.0\text{ V}$  or  $V_{CCx} = 0.0\text{ V}$ ;  $V_{EE} = -5.0\text{ V}$  (Note 1))

Symbol	Characteristic	-40°C			25°C			85°C			Unit
		Min	Typ	Max	Min	Typ	Max	Min	Typ	Max	
$f_{MAX}$	Maximum Toggle Frequency	1100	1400		1100	1400		1100	1400		MHz
$t_{PLH}$ $t_{PHL}$	Propagation Delay to Output CE C <sub>C</sub> R S	310 275 400 300	600 600 635 550	750 725 875 775	360 325 450 350	500 500 640 550	700 675 825 725	360 325 450 350	500 500 640 550	700 675 825 725	ps
$t_S$	Setup Time (Note 2) D	200	20		150	20		150	20		ps
$t_H$	Hold Time (Note 2) D	225	-20		175	-20		175	-20		ps
$t_{RR}$	Reset Recovery Time	450	150		400	150		400	150		ps
$t_{PW}$	Minimum Pulse Width CLK R, S	400 400			400 400			400 400			ps
$t_{SKEW}$	Within-Device Skew (Note 3)		60			60			60		ps
$t_{JITTER}$	Random Clock Jitter		< 1			< 1			< 1		ps
$t_r/t_f$	Rise/Fall Time (20–80%)	275	460	725	300	480		300	480	675	ps

NOTE: Device will meet the specifications after thermal equilibrium has been established when mounted in a test socket or printed circuit board with maintained transverse airflow greater than 500 lfm. Electrical parameters are guaranteed only over the declared operating temperature range. Functional operation of the device exceeding these conditions is not implied. Device specification limit values are applied individually under normal operating conditions and not valid simultaneously.

1. 10 Series:  $V_{EE}$  can vary  $-0.46\text{ V} / +0.06\text{ V}$ .  
100 Series:  $V_{EE}$  can vary  $-0.46\text{ V} / +0.8\text{ V}$ .
2. Setup/hold times guaranteed for both  $C_C$  and  $\overline{CE}$ .
3. Within-device skew is defined as identical transitions on similar paths through a device.

## MC10E131, MC100E131

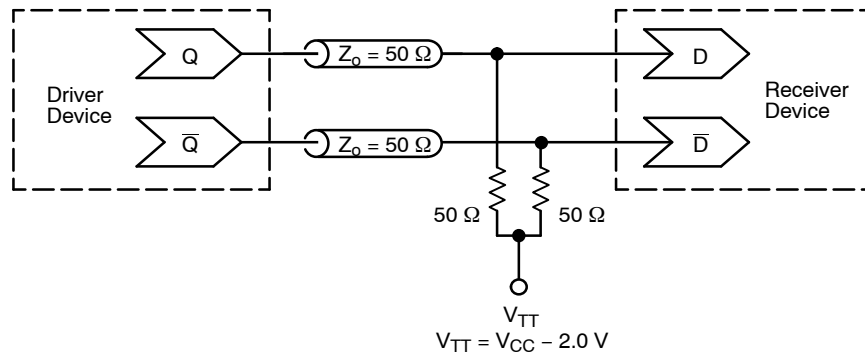

**Figure 3. Typical Termination for Output Driver and Device Evaluation**  
(See Application Note [AND8020/D](#) – Termination of ECL Logic Devices.)

### Resource Reference of Application Notes

- AN1405/D** – ECL Clock Distribution Techniques
- AN1406/D** – Designing with PECL (ECL at +5.0 V)
- AN1503/D** – ECLinPS™ I/O SPICE Modeling Kit
- AN1504/D** – Metastability and the ECLinPS Family
- AN1568/D** – Interfacing Between LVDS and ECL
- AN1672/D** – The ECL Translator Guide
- AND8001/D** – Odd Number Counters Design
- AND8002/D** – Marking and Date Codes
- AND8020/D** – Termination of ECL Logic Devices
- AND8066/D** – Interfacing with ECLinPS
- AND8090/D** – AC Characteristics of ECL Devices

# MC10E131, MC100E131

## PACKAGE DIMENSIONS

28 LEAD PLCC  
CASE 776-02  
ISSUE F

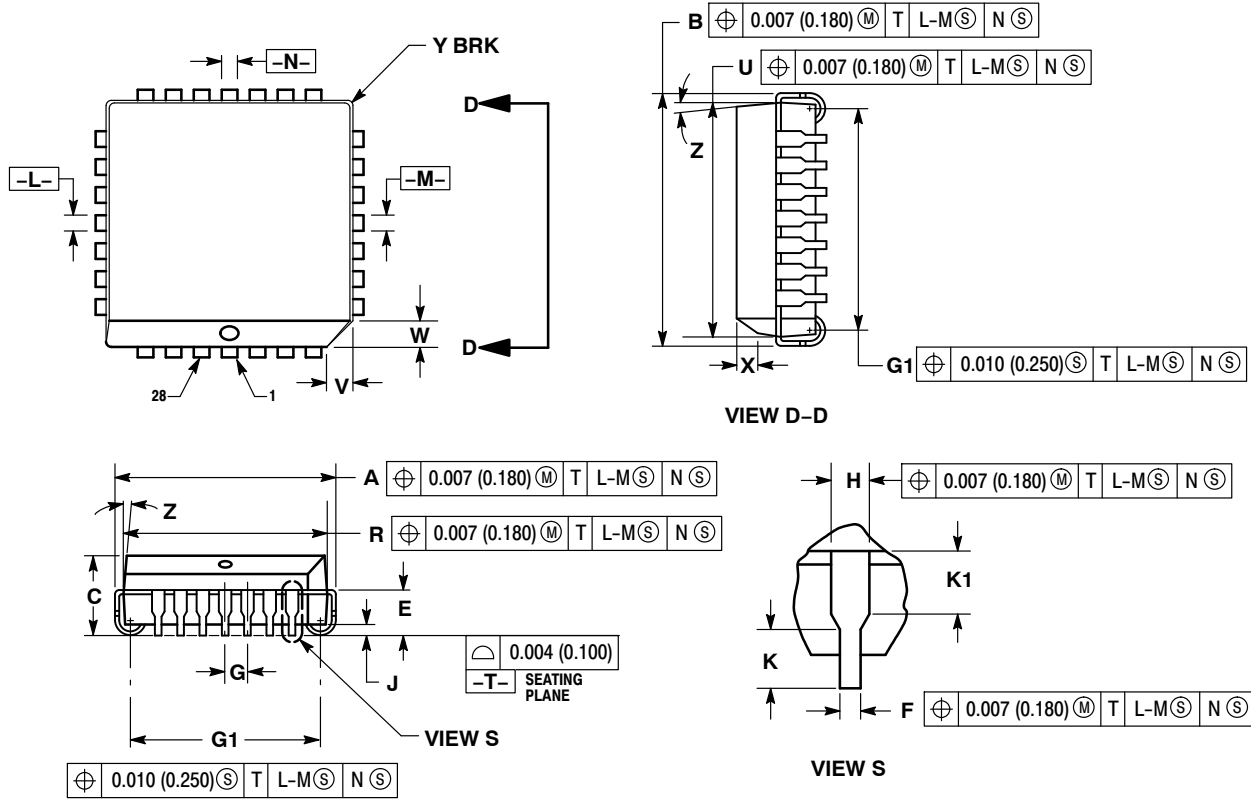

**NOTES:**

- DATUMS -L-, -M-, AND -N- DETERMINED WHERE TOP OF LEAD SHOULDER EXITS PLASTIC BODY AT MOLD PARTING LINE.
- DIMENSION G1, TRUE POSITION TO BE MEASURED AT DATUM -T-, SEATING PLANE.
- DIMENSIONS R AND U DO NOT INCLUDE MOLD FLASH. ALLOWABLE MOLD FLASH IS 0.010 (0.250) PER SIDE.
- DIMENSIONING AND TOLERANCING PER ANSI Y14.5M, 1982.
- CONTROLLING DIMENSION: INCH.
- THE PACKAGE TOP MAY BE SMALLER THAN THE PACKAGE BOTTOM BY UP TO 0.012 (0.300). DIMENSIONS R AND U ARE DETERMINED AT THE OUTERMOST EXTREMES OF THE PLASTIC BODY EXCLUSIVE OF MOLD FLASH, TIE BAR BURRS, GATE BURRS AND INTERLEAD FLASH, BUT INCLUDING ANY MISMATCH BETWEEN THE TOP AND BOTTOM OF THE PLASTIC BODY.
- DIMENSION H DOES NOT INCLUDE DAMBAR PROTRUSION OR INTRUSION. THE DAMBAR PROTRUSION(S) SHALL NOT CAUSE THE H DIMENSION TO BE GREATER THAN 0.037 (0.940). THE DAMBAR INTRUSION(S) SHALL NOT CAUSE THE H DIMENSION TO BE SMALLER THAN 0.025 (0.635).

DIM	INCHES		MILLIMETERS	
	MIN	MAX	MIN	MAX
A	0.485	0.495	12.32	12.57
B	0.485	0.495	12.32	12.57
C	0.165	0.180	4.20	4.57
E	0.090	0.110	2.29	2.79
F	0.013	0.021	0.33	0.53
G	0.050 BSC		1.27 BSC	
H	0.026	0.032	0.66	0.81
J	0.020	---	0.51	---
K	0.025	---	0.64	---
R	0.450	0.456	11.43	11.58
U	0.450	0.456	11.43	11.58
V	0.042	0.048	1.07	1.21
W	0.042	0.048	1.07	1.21
X	0.042	0.056	1.07	1.42
Y	---	0.020	---	0.50
Z	2° 10°		2° 10°	
G1	0.410	0.430	10.42	10.92
K1	0.040	---	1.02	---

# MC10E131, MC100E131

ECLinPS is a registered trademark of Semiconductor Components Industries, LLC (SCILLC) or its subsidiaries in the United States and/or other countries.

ON Semiconductor and  are trademarks of Semiconductor Components Industries, LLC dba ON Semiconductor or its subsidiaries in the United States and/or other countries. ON Semiconductor owns the rights to a number of patents, trademarks, copyrights, trade secrets, and other intellectual property. A listing of ON Semiconductor's product/patent coverage may be accessed at [www.onsemi.com/site/pdf/Patent-Marking.pdf](http://www.onsemi.com/site/pdf/Patent-Marking.pdf). ON Semiconductor reserves the right to make changes without further notice to any products herein. ON Semiconductor makes no warranty, representation or guarantee regarding the suitability of its products for any particular purpose, nor does ON Semiconductor assume any liability arising out of the application or use of any product or circuit, and specifically disclaims any and all liability, including without limitation special, consequential or incidental damages. Buyer is responsible for its products and applications using ON Semiconductor products, including compliance with all laws, regulations and safety requirements or standards, regardless of any support or applications information provided by ON Semiconductor. "Typical" parameters which may be provided in ON Semiconductor data sheets and/or specifications can and do vary in different applications and actual performance may vary over time. All operating parameters, including "Typicals" must be validated for each customer application by customer's technical experts. ON Semiconductor does not convey any license under its patent rights nor the rights of others. ON Semiconductor products are not designed, intended, or authorized for use as a critical component in life support systems or any FDA Class 3 medical devices or medical devices with a same or similar classification in a foreign jurisdiction or any devices intended for implantation in the human body. Should Buyer purchase or use ON Semiconductor products for any such unintended or unauthorized application, Buyer shall indemnify and hold ON Semiconductor and its officers, employees, subsidiaries, affiliates, and distributors harmless against all claims, costs, damages, and expenses, and reasonable attorney fees arising out of, directly or indirectly, any claim of personal injury or death associated with such unintended or unauthorized use, even if such claim alleges that ON Semiconductor was negligent regarding the design or manufacture of the part. ON Semiconductor is an Equal Opportunity/Affirmative Action Employer. This literature is subject to all applicable copyright laws and is not for resale in any manner.

## PUBLICATION ORDERING INFORMATION

### LITERATURE FULFILLMENT:

Literature Distribution Center for ON Semiconductor  
19521 E. 32nd Pkwy, Aurora, Colorado 80011 USA  
**Phone:** 303-675-2175 or 800-344-3860 Toll Free USA/Canada  
**Fax:** 303-675-2176 or 800-344-3867 Toll Free USA/Canada  
**Email:** [orderlit@onsemi.com](mailto:orderlit@onsemi.com)

**N. American Technical Support:** 800-282-9855 Toll Free  
USA/Canada  
**Europe, Middle East and Africa Technical Support:**  
Phone: 421 33 790 2910  
**Japan Customer Focus Center**  
Phone: 81-3-5817-1050

**ON Semiconductor Website:** [www.onsemi.com](http://www.onsemi.com)  
**Order Literature:** <http://www.onsemi.com/orderlit>  
For additional information, please contact your local  
Sales Representative

## Looking for pricing, stock, or lifecycle information?

Click below to explore more details on WIN SOURCE:

 [View MC10E131FNR2G on WIN SOURCE](#)

 [ON Semiconductor](#) Information

## Optimize Your Supply Chain with WIN SOURCE Solutions

-  Global Sourcing Solution
-  Obsolete Management
-  Cost Control Management
-  Shortage Management
-  Alternative Solution
-  Excess Inventory Management