

MC100LVELT23

3.3 V Dual Differential LVPECL/LVDS to LVTTTL Translator

Description

The MC100LVELT23 is a dual differential LVPECL/LVDS to LVTTTL translator. Because LVPECL (Positive ECL) or LVDS levels are used only +3.3 V and ground are required. The small outline 8-lead package and the dual gate design of the LVELT23 makes it ideal for applications which require the translation of a clock and a data signal.

The LVELT23 is available in only the ECL 100K standard. Since there are no LVPECL outputs or an external V_{BB} reference, the LVELT23 does not require both ECL standard versions. The LVPECL inputs are differential. Therefore, the MC100LVELT23 can accept any standard differential LVPECL input referenced from a V_{CC} of +3.3 V.

Features

- 2.0 ns Typical Propagation Delay
- Maximum Frequency > 180 MHz
- Differential LVPECL Inputs
- PECL Mode Operating Range: $V_{CC} = 3.0\text{ V to } 3.8\text{ V}$ with $GND = 0\text{ V}$
- 24 mA LVTTTL Outputs
- Flow Through Pinouts
- Internal Pulldown and Pullup Resistors
- These Devices are Pb-Free, Halogen Free and are RoHS Compliant



ON Semiconductor®

www.onsemi.com



SOIC-8 NB
D SUFFIX
CASE 751-07



TSSOP-8
DT SUFFIX
CASE 948R-02



DFN-8
MN SUFFIX
CASE 506AA

MARKING DIAGRAMS*

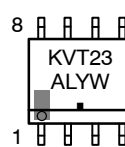

SOIC-8

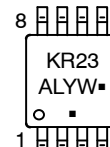

TSSOP-8

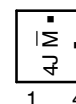

DFN-8

- A = Assembly Location
- L = Wafer Lot
- Y = Year
- W = Work Week
- M = Date Code
- = Pb-Free Package

(Note: Microdot may be in either location)

*For additional marking information, refer to Application Note [AND8002/D](#).

ORDERING INFORMATION

Device	Package	Shipping†
MC100LVELT23DG	SOIC-8 NB (Pb-Free)	98 Units/Tube
MC100LVELT23DR2G	SOIC-8 NB (Pb-Free)	2500/Tape & Reel
MC100LVELT23DTG	TSSOP-8 (Pb-Free)	100 Units/Tube
MC100LVELT23DTRG	TSSOP-8 (Pb-Free)	2500/Tape & Reel
MC100LVELT23MNRG	DFN-8 (Pb-Free)	1000/Tape & Reel

†For information on tape and reel specifications, including part orientation and tape sizes, please refer to our Tape and Reel Packaging Specifications Brochure, [BRD8011/D](#).

MC100LVELT23

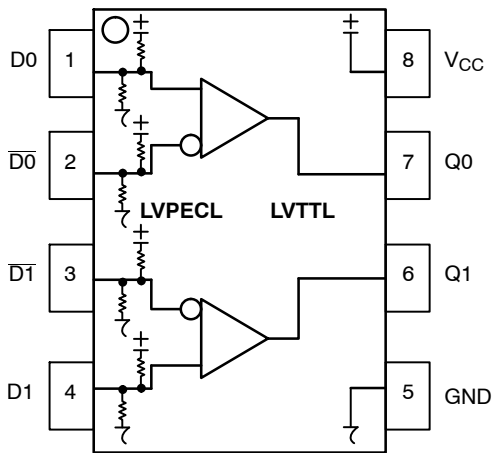

Figure 1. 8-Lead Pinout (Top View) and Logic Diagram

Table 1. PIN DESCRIPTION

Pin	Function
Q0, Q1 D0*, D1* D0-bar*, D1-bar*	LVTTTL Outputs Differential LVPECL Inputs
V _{CC} GND EP	Positive Supply Ground (DFN8 only) Thermal exposed pad must be connected to a sufficient thermal conduit. Electrically connect to the most negative supply (GND) or leave unconnected, floating open.

** Pins will default to $V_{CC}/2$ when left open.

Table 2. ATTRIBUTES

Characteristics	Value
Internal Input Pulldown Resistor	50 k Ω
Internal Input Pullup Resistor	50 k Ω
ESD Protection Human Body Model Machine Model CDM	> 1500 V > 100 V > 2000 V
Moisture Sensitivity, Indefinite Time Out of Drypack (Note 1)	Pb-Free Pkg
SOIC-8 NB TSSOP-8 DFN-8	Level 1 Level 3 Level 1
Flammability Rating Oxygen Index: 28 to 34	UL 94 V-0 @ 0.125 in
Transistor Count	91
Meets or Exceeds JEDEC Spec EIA/JESD78 IC Latchup Test	

1. Refer to Application Note [AND8003/D](#) for additional information.

MC100LVELT23

Table 3. MAXIMUM RATINGS

Symbol	Parameter	Condition 1	Condition 2	Rating	Unit
V _{CC}	PECL Power Supply	GND = 0 V		3.8	V
V _I	Input Voltage	GND = 0 V, V _I not more positive than V _{CC}		3.8	V
I _{out}	Output Current	Continuous Surge		50 100	mA
T _A	Operating Temperature Range			-40 to +85	°C
T _{stg}	Storage Temperature			-65 to +150	°C
θ _{JA}	Thermal Resistance (Junction-to-Ambient)	0 lfpm 500 lfpm	SOIC-8 NB	190 130	°C/W
θ _{JC}	Thermal Resistance (Junction-to-Case)	Standard Board	SOIC-8 NB	41 to 44 ± 5%	°C/W
θ _{JA}	Thermal Resistance (Junction-to-Ambient)	0 lfpm 500 lfpm	TSSOP-8	185 140	°C/W
θ _{JC}	Thermal Resistance (Junction-to-Case)	Standard Board	TSSOP-8	41 to 44 ± 5%	°C/W
θ _{JA}	Thermal Resistance (Junction-to-Ambient)	0 lfpm 500 lfpm	DFN-8	129 84	°C/W
T _{sol}	Wave Solder Pb-Free	< 2 to 3 sec @ 260°C		265	°C
θ _{JC}	Thermal Resistance (Junction-to-Case)	(Note 1)	DFN-8	35 to 40	°C/W

Stresses exceeding those listed in the Maximum Ratings table may damage the device. If any of these limits are exceeded, device functionality should not be assumed, damage may occur and reliability may be affected.

- JEDEC standard multilayer board – 2S2P (2 signal, 2 power)

Table 4. LVPECL INPUT DC CHARACTERISTICS (V_{CC} = 3.3 V; GND = 0 V (Note 1))

Symbol	Characteristic	-40°C			25°C			85°C			Unit
		Min	Typ	Max	Min	Typ	Max	Min	Typ	Max	
I _{CCH}	Power Supply Current (Outputs set to HIGH)	10	20	35	10	20	35	10	20	35	mA
I _{CCL}	Power Supply Current (Outputs set to LOW)	15	27	40	15	27	40	15	27	40	mA
V _{IH}	Input HIGH Voltage (Note 3)	2135		2420	2135		2420	2135		2420	mV
V _{IL}	Input LOW Voltage (Note 3)	1490		1825	1490		1825	1490		1825	mV
V _{IHCMR}	Input HIGH Voltage Common Mode Range (Notes 2 and 3)	1.2		V _{CC}	1.2		V _{CC}	1.2		V _{CC}	V
I _{IH}	Input HIGH Current			150			150			150	μA
I _{IL}	Input LOW Current	\bar{D}	-150		-150			-150			μA

NOTE: Device will meet the specifications after thermal equilibrium has been established when mounted in a test socket or printed circuit board with maintained transverse airflow greater than 500 lfpm. Electrical parameters are guaranteed only over the declared operating temperature range. Functional operation of the device exceeding these conditions is not implied. Device specification limit values are applied individually under normal operating conditions and not valid simultaneously.

- All values vary 1:1 with V_{CC}. V_{CC} can vary ±0.3 V.
- V_{IHCMR} min varies 1:1 with GND, max varies 1:1 with V_{CC}.
- LVTTTL output R_L = 500 Ω to GND.

MC100LVELT23

Table 5. LVTTTL OUTPUT DC CHARACTERISTICS ($V_{CC} = 3.3\text{ V}$; $GND = 0\text{ V}$ (Note 1))

Symbol	Characteristic	-40°C			25°C			85°C			Unit
		Min	Typ	Max	Min	Typ	Max	Min	Typ	Max	
V_{OH}	Output HIGH Voltage ($I_{OH} = -3.0\text{ mA}$) (Note 2)	2.4			2.4			2.4			V
V_{OL}	Output LOW Voltage ($I_{OL} = 24\text{ mA}$) (Note 2)			0.5			0.5			0.5	V
I_{OS}	Output Short Circuit Current	-180		-50	-180		-50	-180		-50	mA

NOTE: Device will meet the specifications after thermal equilibrium has been established when mounted in a test socket or printed circuit board with maintained transverse airflow greater than 500 lpm. Electrical parameters are guaranteed only over the declared operating temperature range. Functional operation of the device exceeding these conditions is not implied. Device specification limit values are applied individually under normal operating conditions and not valid simultaneously.

1. All values vary 1:1 with V_{CC} . V_{CC} can vary $\pm 0.3\text{ V}$.
2. LVTTTL output $R_L = 500\ \Omega$ to GND.

Table 6. AC CHARACTERISTICS ($V_{CC} = 3.3\text{ V}$; $GND = 0\text{ V}$ (Notes 1, 2))

Symbol	Characteristic	-40°C			25°C			85°C			Unit
		Min	Typ	Max	Min	Typ	Max	Min	Typ	Max	
F_{max}	Maximum Toggle Frequency (Note 3)	180			180			180			MHz
t_{PLH} , t_{PHL}	Propagation Delay to Output Differential	1.0	1.5	2.5	1.0	1.7	2.5	1.0	1.7	2.5	ns
t_{SK++} , t_{SK--} , t_{SKPP}	Output-to-Output Skew++ Output-to-Output Skew-- Part-to-Part Skew (Note 4)		15 35 70	60 80 500		15 40 70	70 80 500		30 40 140	125 80 500	ps
t_{JITTER}	Random Clock Jitter (RMS)		4.0	10		4.0	10		4.0	10	ps
V_{PP}	Input Voltage Swing (Differential Configuration) (Note 5)	200	800	1000	200	800	1000	200	800	1000	mV
t_r , t_f	Output Rise/Fall Times (0.8 V – 2.0 V) Q, \bar{Q}	330	600	900	330	600	900	330	650	900	ps

NOTE: Device will meet the specifications after thermal equilibrium has been established when mounted in a test socket or printed circuit board with maintained transverse airflow greater than 500 lpm. Electrical parameters are guaranteed only over the declared operating temperature range. Functional operation of the device exceeding these conditions is not implied. Device specification limit values are applied individually under normal operating conditions and not valid simultaneously.

1. All values vary 1:1 with V_{CC} . V_{CC} can vary $\pm 0.3\text{ V}$.
2. LVTTTL output $R_L = 500\ \Omega$ to GND and $C_L = 20\text{ pF}$ to GND. Refer to Figure 2.
3. F_{max} guaranteed for functionality only. V_{OL} and V_{OH} levels are guaranteed at DC only.
4. Skews are measured between outputs under identical conditions.
5. 200 mV input guarantees full logic swing at the output.

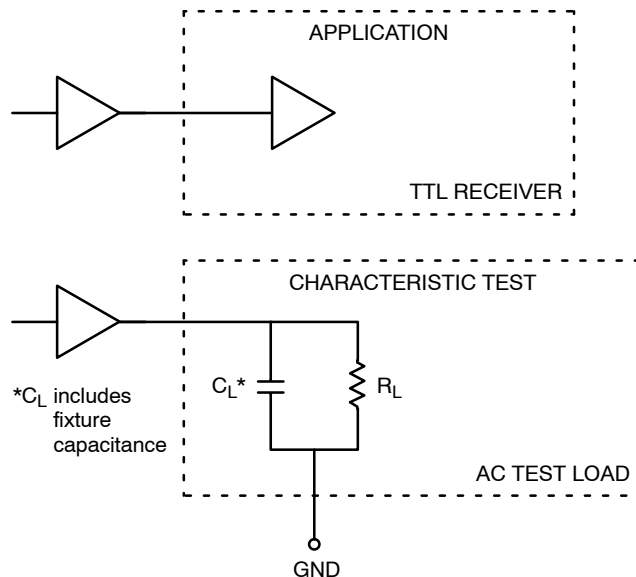

Figure 2. TTL Output Loading Used for Device Evaluation

MC100LVELT23

Resource Reference of Application Notes

- AN1405/D** – ECL Clock Distribution Techniques
- AN1406/D** – Designing with PECL (ECL at +5.0 V)
- AN1503/D** – ECLinPS™ I/O SPiCE Modeling Kit
- AN1504/D** – Metastability and the ECLinPS Family
- AN1568/D** – Interfacing Between LVDS and ECL
- AN1672/D** – The ECL Translator Guide
- AND8001/D** – Odd Number Counters Design
- AND8002/D** – Marking and Date Codes
- AND8020/D** – Termination of ECL Logic Devices
- AND8066/D** – Interfacing with ECLinPS
- AND8090/D** – AC Characteristics of ECL Devices

MC100LVELT23

PACKAGE DIMENSIONS

SOIC-8 NB
CASE 751-07
ISSUE AK

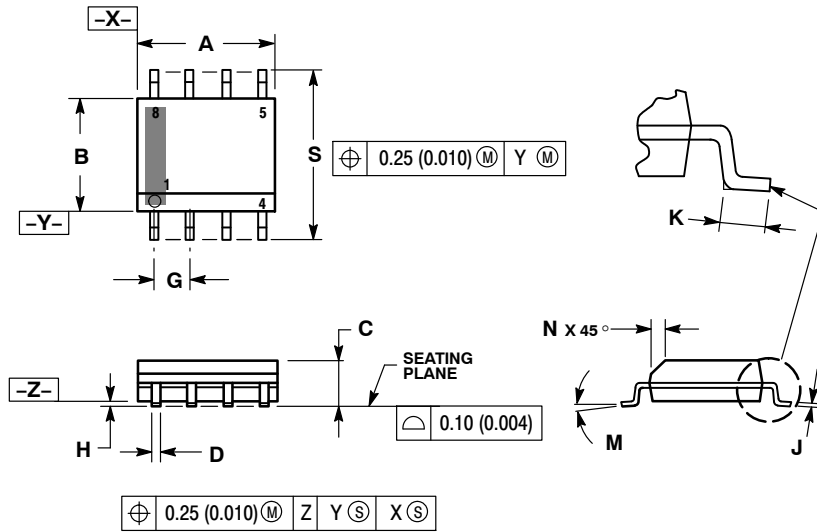

NOTES:

1. DIMENSIONING AND TOLERANCING PER ANSI Y14.5M, 1982.
2. CONTROLLING DIMENSION: MILLIMETER.
3. DIMENSION A AND B DO NOT INCLUDE MOLD PROTRUSION.
4. MAXIMUM MOLD PROTRUSION 0.15 (0.006) PER SIDE.
5. DIMENSION D DOES NOT INCLUDE DAMBAR PROTRUSION. ALLOWABLE DAMBAR PROTRUSION SHALL BE 0.127 (0.005) TOTAL IN EXCESS OF THE D DIMENSION AT MAXIMUM MATERIAL CONDITION.
6. 751-01 THRU 751-06 ARE OBSOLETE. NEW STANDARD IS 751-07.

DIM	MILLIMETERS		INCHES	
	MIN	MAX	MIN	MAX
A	4.80	5.00	0.189	0.197
B	3.80	4.00	0.150	0.157
C	1.35	1.75	0.053	0.069
D	0.33	0.51	0.013	0.020
G	1.27 BSC		0.050 BSC	
H	0.10	0.25	0.004	0.010
J	0.19	0.25	0.007	0.010
K	0.40	1.27	0.016	0.050
M	0°	8°	0°	8°
N	0.25	0.50	0.010	0.020
S	5.80	6.20	0.228	0.244

SOLDERING FOOTPRINT*

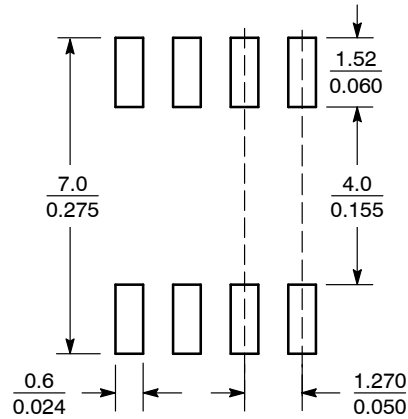

SCALE 6:1 $\left(\frac{\text{mm}}{\text{inches}}\right)$

*For additional information on our Pb-Free strategy and soldering details, please download the ON Semiconductor Soldering and Mounting Techniques Reference Manual, [SOLDERRM/D](#).

MC100LVELT23

PACKAGE DIMENSIONS

TSSOP-8
CASE 948R-02
ISSUE A

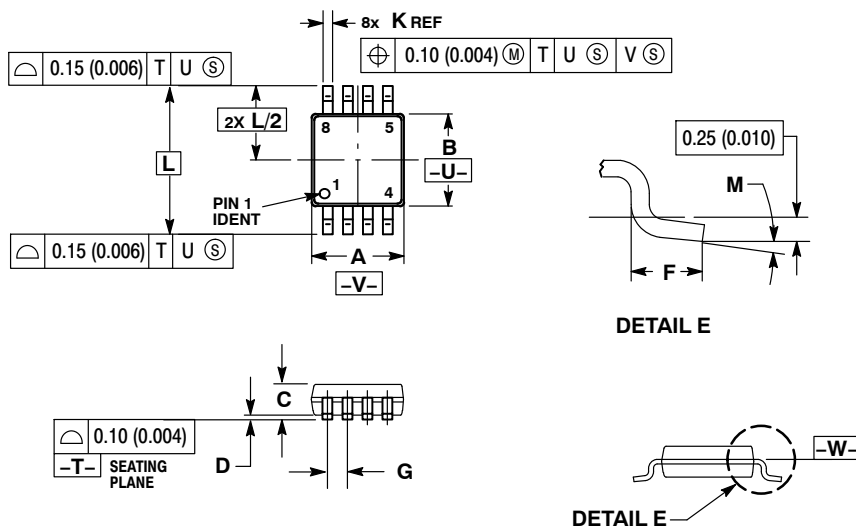

- NOTES:
1. DIMENSIONING AND TOLERANCING PER ANSI Y14.5M, 1982.
 2. CONTROLLING DIMENSION: MILLIMETER.
 3. DIMENSION A DOES NOT INCLUDE MOLD FLASH. PROTRUSIONS OR GATE BURRS. MOLD FLASH OR GATE BURRS SHALL NOT EXCEED 0.15 (0.006) PER SIDE.
 4. DIMENSION B DOES NOT INCLUDE INTERLEAD FLASH OR PROTRUSION. INTERLEAD FLASH OR PROTRUSION SHALL NOT EXCEED 0.25 (0.010) PER SIDE.
 5. TERMINAL NUMBERS ARE SHOWN FOR REFERENCE ONLY.
 6. DIMENSION A AND B ARE TO BE DETERMINED AT DATUM PLANE -W-.

DIM	MILLIMETERS		INCHES	
	MIN	MAX	MIN	MAX
A	2.90	3.10	0.114	0.122
B	2.90	3.10	0.114	0.122
C	0.80	1.10	0.031	0.043
D	0.05	0.15	0.002	0.006
F	0.40	0.70	0.016	0.028
G	0.65 BSC		0.026 BSC	
K	0.25	0.40	0.010	0.016
L	4.90 BSC		0.193 BSC	
M	0°	6°	0°	6°

MC100LVELT23

PACKAGE DIMENSIONS

DFN-8 2x2, 0.5P
CASE 506AA
ISSUE F

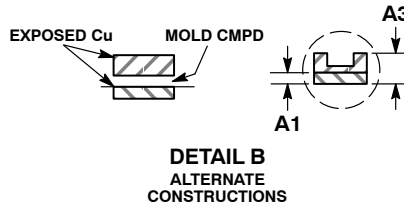
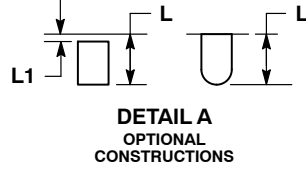
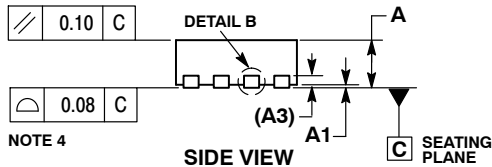
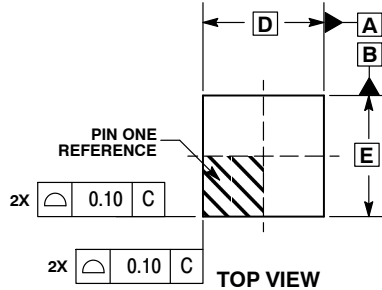

NOTES:

1. DIMENSIONING AND TOLERANCING PER ASME Y14.5M, 1994.
2. CONTROLLING DIMENSION: MILLIMETERS.
3. DIMENSION b APPLIES TO PLATED TERMINAL AND IS MEASURED BETWEEN 0.15 AND 0.20 MM FROM TERMINAL TIP.
4. COPLANARITY APPLIES TO THE EXPOSED PAD AS WELL AS THE TERMINALS.

MILLIMETERS		
DIM	MIN	MAX
A	0.80	1.00
A1	0.00	0.05
A3	0.20	REF
b	0.20	0.30
D	2.00	BSC
D2	1.10	1.30
E	2.00	BSC
E2	0.70	0.90
e	0.50	BSC
K	0.30	REF
L	0.25	0.35
L1	---	0.10

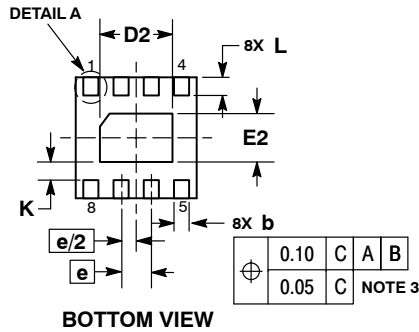

RECOMMENDED SOLDERING FOOTPRINT*

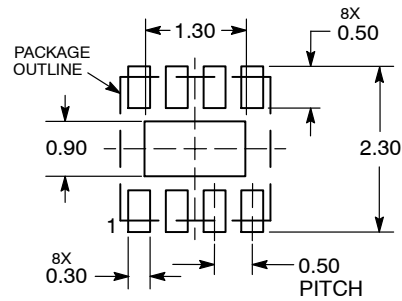

DIMENSIONS: MILLIMETERS

*For additional information on our Pb-Free strategy and soldering details, please download the ON Semiconductor Soldering and Mounting Techniques Reference Manual, [SOLDDRM/D](#).

ECLinPS is a registered trademark of Semiconductor Components Industries, LLC (SCILLC) or its subsidiaries in the United States and/or other countries.

ON Semiconductor and are trademarks of Semiconductor Components Industries, LLC dba ON Semiconductor or its subsidiaries in the United States and/or other countries. ON Semiconductor owns the rights to a number of patents, trademarks, copyrights, trade secrets, and other intellectual property. A listing of ON Semiconductor's product/patent coverage may be accessed at www.onsemi.com/site/pdf/Patent-Marking.pdf. ON Semiconductor reserves the right to make changes without further notice to any products herein. ON Semiconductor makes no warranty, representation or guarantee regarding the suitability of its products for any particular purpose, nor does ON Semiconductor assume any liability arising out of the application or use of any product or circuit, and specifically disclaims any and all liability, including without limitation special, consequential or incidental damages. Buyer is responsible for its products and applications using ON Semiconductor products, including compliance with all laws, regulations and safety requirements or standards, regardless of any support or applications information provided by ON Semiconductor. "Typical" parameters which may be provided in ON Semiconductor data sheets and/or specifications can and do vary in different applications and actual performance may vary over time. All operating parameters, including "Typicals" must be validated for each customer application by customer's technical experts. ON Semiconductor does not convey any license under its patent rights nor the rights of others. ON Semiconductor products are not designed, intended, or authorized for use as a critical component in life support systems or any FDA Class 3 medical devices or medical devices with a same or similar classification in a foreign jurisdiction or any devices intended for implantation in the human body. Should Buyer purchase or use ON Semiconductor products for any such unintended or unauthorized application, Buyer shall indemnify and hold ON Semiconductor and its officers, employees, subsidiaries, affiliates, and distributors harmless against all claims, costs, damages, and expenses, and reasonable attorney fees arising out of, directly or indirectly, any claim of personal injury or death associated with such unintended or unauthorized use, even if such claim alleges that ON Semiconductor was negligent regarding the design or manufacture of the part. ON Semiconductor is an Equal Opportunity/Affirmative Action Employer. This literature is subject to all applicable copyright laws and is not for resale in any manner.

PUBLICATION ORDERING INFORMATION

LITERATURE FULFILLMENT:
Literature Distribution Center for ON Semiconductor
19521 E. 32nd Pkwy, Aurora, Colorado 80011 USA
Phone: 303-675-2175 or 800-344-3860 Toll Free USA/Canada
Fax: 303-675-2176 or 800-344-3867 Toll Free USA/Canada
Email: orderlit@onsemi.com

N. American Technical Support: 800-282-9855 Toll Free
USA/Canada
Europe, Middle East and Africa Technical Support:
Phone: 421 33 790 2910
Japan Customer Focus Center
Phone: 81-3-5817-1050

ON Semiconductor Website: www.onsemi.com
Order Literature: <http://www.onsemi.com/orderlit>

For additional information, please contact your local Sales Representative

Looking for pricing, stock, or lifecycle information?

Click below to explore more details on WIN SOURCE:

 [View MC100LVELT23DTG on WIN SOURCE](#)

 [ON Semiconductor](#) Information

Optimize Your Supply Chain with WIN SOURCE Solutions

-  Global Sourcing Solution
-  Obsolete Management
-  Cost Control Management
-  Shortage Management
-  Alternative Solution
-  Excess Inventory Management