



**THE DATASHEET OF  
MC100ES6011D**



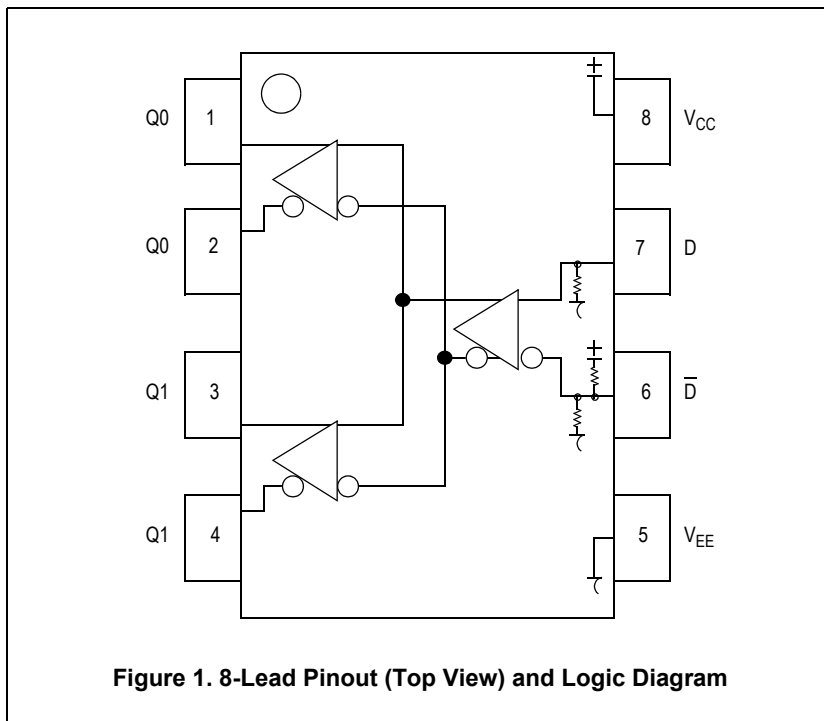
## 2.5 V/3.3 V ECL 1:2 Differential Fanout Buffer

The MC100ES6011 is a differential 1:2 fanout buffer. The ES6011 is ideal for applications requiring lower voltage.

The 100ES Series contains temperature compensation.

### Features

- 270 ps Typical Propagation Delay
- Maximum Frequency > 3 GHz Typical
- PECL Mode Operating Range:  $V_{CC} = 2.375\text{ V to }3.8\text{ V}$  with  $V_{EE} = 0\text{ V}$
- ECL Mode Operating Range:  $V_{CC} = 0\text{ V}$  with  $V_{EE} = -2.375\text{ V to }-3.8\text{ V}$
- Open Input Default State
- Q Output Will Default LOW with Inputs Open or at  $V_{EE}$
- LVDS Input Compatible
- 8-Lead SOIC and TSSOP Pb-Free Packages Available



## MC100ES6011

**D SUFFIX**  
 8-LEAD SOIC PACKAGE  
 CASE 751-07

**EF SUFFIX**  
 8-LEAD SOIC PACKAGE  
 Pb-FREE PACKAGE  
 CASE 751-07

**DT SUFFIX**  
 8-LEAD TSSOP PACKAGE  
 CASE 1640-01

**EJ SUFFIX**  
 8-LEAD TSSOP PACKAGE  
 Pb-FREE PACKAGE  
 CASE 1640-01

### ORDERING INFORMATION

Device	Package
MC100ES6011D	SO-8
MC100ES6011DR2	SO-8
MC100ES6011EF	SO-8 (Pb-Free)
MC100ES6011EFR2	SO-8 (Pb-Free)
MC100ES6011DT	TSSOP-8
MC100ES6011DTR2	TSSOP-8
MC100ES6011EJ	TSSOP-8 (Pb-Free)
MC100ES6011EJR2	TSSOP-8 (Pb-Free)

### PIN DESCRIPTION

Pin	Function
D <sup>(1)</sup> , D <sup>(2)</sup>	ECL Data Inputs
Q0, Q0 Q1, Q1	ECL Data Outputs
V <sub>CC</sub>	Positive Supply
V <sub>EE</sub>	Negative Supply

1. Pins will default LOW when left open.
2. Pins will default to  $0.572 V_{CC}/2$  when left open.

**Table 1. Attributes**

Characteristics		Value
Internal Input Pulldown Resistor		75 k $\Omega$
Internal Input Pullup Resistor		56 k $\Omega$
ESD Protection	Human Body Model	> 4000 V
	Machine Model	> 200 V
	Charged Device Model	> 1500 V
$\theta_{JA}$ Thermal Resistance (Junction to Ambient)	0 LFPM, 8 SOIC 500 LFPM, 8 SOIC	190°C/W 130°C/W

Meets or exceeds JEDEC Spec EIA/JESD78 IC Latchup Test

**Table 2. Maximum Ratings<sup>(1)</sup>**

Symbol	Parameter	Conditions	Rating	Units
$V_{SUPPLY}$	Power Supply Voltage	Difference between $V_{CC}$ & $V_{EE}$	3.9	V
$V_{IN}$	Input Voltage	$V_{CC}-V_{EE} < 3.6$ V	$V_{CC} + 0.3$ $V_{EE} - 0.3$	V V
$I_{OUT}$	Output Current	Continuous Surge	50 100	mA mA
$T_A$	Operating Temperature Range		-40 to +85	°C
$T_{stg}$	Storage Temperature Range		-65 to +150	°C

1. Absolute maximum continuous ratings are those maximum values beyond which damage to the device may occur. Exposure to these conditions or conditions beyond those indicated may adversely affect device reliability. Functional operation at absolute-maximum-rated conditions is not implied.

**Table 3. DC Characteristics ( $V_{CC} = 0$  V;  $V_{EE} = -2.5$  V  $\pm$  5% or  $V_{CC} = 2.5$  V  $\pm$  5%;  $V_{EE} = 0$  V)<sup>(1)</sup>**

Symbol	Characteristic	-40°C			0°C to 85°C			Unit
		Min	Typ	Max	Min	Typ	Max	
$I_{EE}$	Power Supply Current		12	25		12	25	mA
$V_{OH}$	Output HIGH Voltage <sup>(2)</sup>	$V_{CC}-1135$		$V_{CC}-760$	$V_{CC}-1070$		$V_{CC}-760$	mV
$V_{OL}$	Output LOW Voltage <sup>(2)</sup>	$V_{CC}-1950$		$V_{CC}-1350$	$V_{CC}-1950$		$V_{CC}-1520$	mV
$V_{OUTPP}$	Output Peak-to-Peak Voltage	200			200			mV
$V_{IH}$	Input HIGH Voltage (Single Ended)	$V_{CC}-1165$		$V_{CC}-880$	$V_{CC}-1165$		$V_{CC}-880$	mV
$V_{IL}$	Input LOW Voltage (Single Ended)	$V_{CC}-1810$		$V_{CC}-1475$	$V_{CC}-1810$		$V_{CC}-1475$	mV
$V_{PP}$	Differential Input Voltage <sup>(3)</sup>	0.12		1.3	0.12		1.3	V
$V_{CMR}$	Differential Cross Point Voltage <sup>(4)</sup>	$V_{EE} + 1.0$		$V_{CC} - 0.8$	$V_{EE} + 1.0$		$V_{CC} - 0.8$	V
$I_{IN}$	Input Current			$\pm 150$			$\pm 150$	$\mu$ A

- ES6011 circuits are designed to meet the DC specifications shown in the above table after thermal equilibrium has been established. The circuit is in a test socket or mounted on a printed circuit board and transverse airflow > 500 LFPM is maintained.
- Output termination voltage  $V_{TT} = 0$  V for  $V_{CC} = 2.5$  V operation is supported but the power consumption of the device will increase.
- $V_{PP}$  (DC) is the minimum differential input voltage swing required to maintain device functionality.
- $V_{CMR}$  (DC) is the crosspoint of the differential input signal. Functional operation is obtained when the crosspoint is within the  $V_{CMR}$  (DC) range and the input swing lies within the  $V_{PP}$  (DC) specification.

**Table 4. DC Characteristics** ( $V_{CC} = 0\text{ V}$ ;  $V_{EE} = -3.8\text{ to }-3.135\text{ or }V_{CC} = 3.8\text{ to }3.135\text{ V}$ ;  $V_{EE} = 0\text{ V}$ )<sup>(1)</sup>

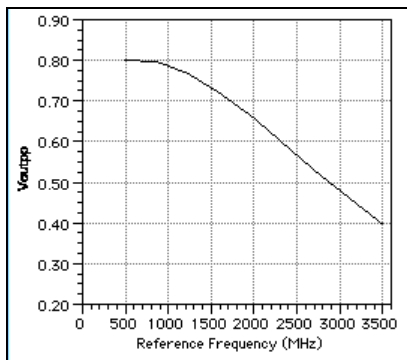
Symbol	Characteristic	-40°C			0°C to 85°C			Unit
		Min	Typ	Max	Min	Typ	Max	
$I_{EE}$	Power Supply Current		12	25		12	25	mA
$V_{OH}$	Output HIGH Voltage <sup>(2)</sup>	$V_{CC}-1135$		$V_{CC}-760$	$V_{CC}-1070$		$V_{CC}-760$	mV
$V_{OL}$	Output LOW Voltage <sup>(2)</sup>	$V_{CC}-1950$		$V_{CC}-1500$	$V_{CC}-1950$		$V_{CC}-1520$	mV
$V_{OUTPP}$	Output Peak-to-Peak Voltage	200			200			mV
$V_{IH}$	Input HIGH Voltage (Single Ended)	$V_{CC}-1165$		$V_{CC}-880$	$V_{CC}-1165$		$V_{CC}-880$	mV
$V_{IL}$	Input LOW Voltage (Single Ended)	$V_{CC}-1810$		$V_{CC}-1475$	$V_{CC}-1810$		$V_{CC}-1475$	mV
$V_{PP}$	Differential Input Voltage <sup>(3)</sup>	0.12		1.3	0.12		1.3	V
$V_{CMR}$	Differential Cross Point Voltage <sup>(4)</sup>	$V_{EE}+1.0$		$V_{CC}-0.8$	$V_{EE}+1.0$		$V_{CC}-0.8$	V
$I_{IN}$	Input Current			$\pm 150$			$\pm 150$	$\mu\text{A}$

- ES6011 circuits are designed to meet the DC specifications shown in the above table after thermal equilibrium has been established. The circuit is in a test socket or mounted on a printed circuit board and transverse airflow > 500 LFPM is maintained.
- Output termination voltage  $V_{TT} = 0\text{ V}$  for  $V_{CC} = 2.5\text{ V}$  operation is supported but the power consumption of the device will increase.
- $V_{PP}$  (DC) is the minimum differential input voltage swing required to maintain device functionality.
- $V_{CMR}$  (DC) is the crosspoint of the differential input signal. Functional operation is obtained when the crosspoint is within the  $V_{CMR}$  (DC) range and the input swing lies within the  $V_{PP}$  (DC) specification.

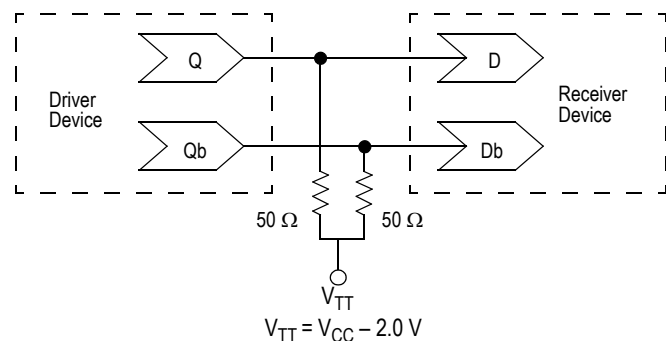
**Table 5. AC Characteristics** ( $V_{CC} = 0\text{ V}$ ;  $V_{EE} = -3.8\text{ to }-2.375\text{ or }V_{CC} = 2.375\text{ to }3.8\text{ V}$ ;  $V_{EE} = 0\text{ V}$ )<sup>(1)</sup>

Symbol	Characteristic	-40°C			25°C			0°C to 85°C			Unit
		Min	Typ	Max	Min	Typ	Max	Min	Typ	Max	
$f_{MAX}$	Maximum Frequency		> 3			> 3			> 3		GHz
$t_{PLH}$ , $t_{PHL}$	Propagation Delay (Differential) CLK to Q, $\bar{Q}$	170	260	300	180	270	310	210	285	360	ps
$t_{SKEW}$	Within Device Skew Q, $\bar{Q}$ Device-to-Device Skew <sup>(2)</sup>		9	20 130		9	20 130		9	20 150	ps
$t_{JITTER}$	Cycle-to-Cycle Jitter RMS ( $1\sigma$ )			1			1			1	ps
$V_{PP}$	Input Voltage Swing (Differential)	150		1200	150		1200	150		1200	mV
$V_{CMR}$	Differential Cross Point Voltage	$V_{EE}+1.2$		$V_{CC}-1.1$	$V_{EE}+1.2$		$V_{CC}-1.1$	$V_{EE}+1.2$		$V_{CC}-1.1$	V
$t_r$ $t_f$	Output Rise/Fall Times (20% – 80%)	70		220	70		220	70		220	ps

- Measured using a 750 mV source 50% Duty Cycle clock source. All loading with  $50\ \Omega$  to  $V_{CC}-2.0\text{ V}$ .
- Skew is measured between outputs under identical transitions.

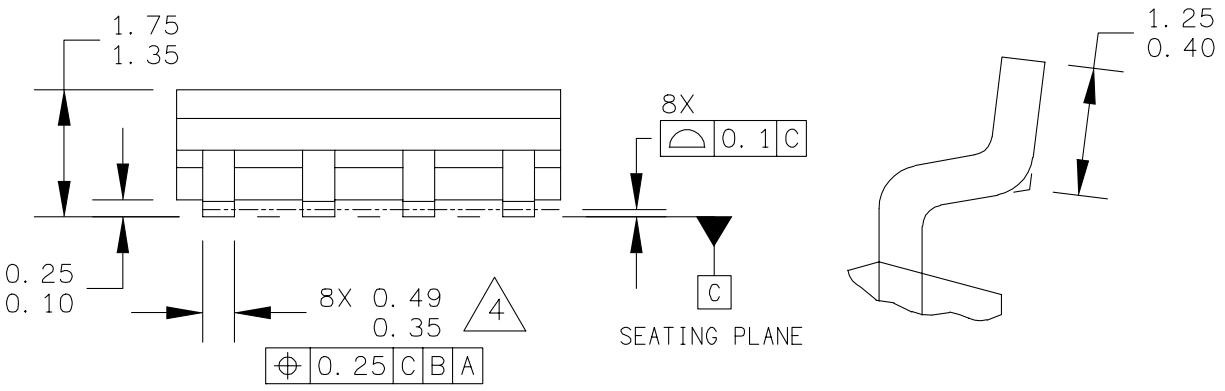
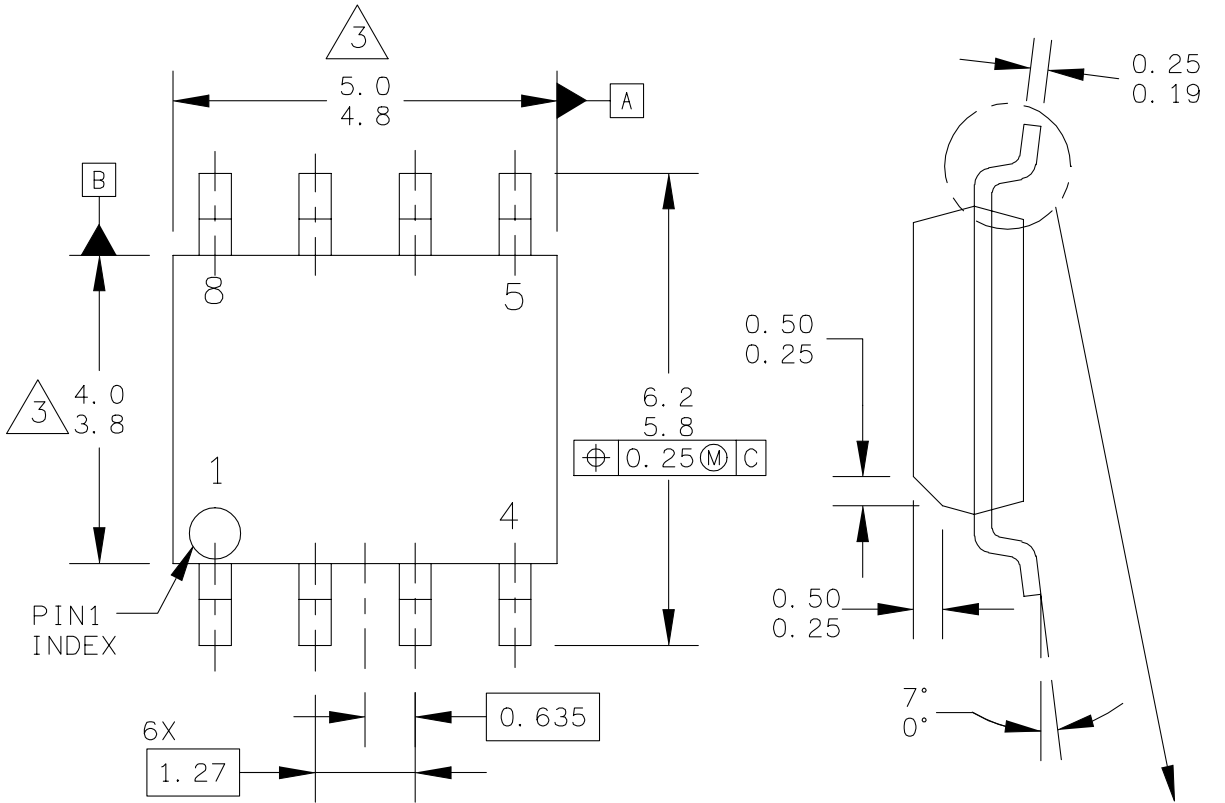


**Figure 2.  $V_{OUTPP}$  versus Frequency**



**Figure 3. Typical Termination for Output Driver and Device Evaluation**

# PACKAGE DIMENSIONS



© FREESCALE SEMICONDUCTOR, INC. ALL RIGHTS RESERVED.	MECHANICAL OUTLINE	PRINT VERSION NOT TO SCALE	
TITLE:  8LD SOIC NARROW BODY	DOCUMENT NO: 98ASB42564B	REV: U	
	CASE NUMBER: 751-07	07 APR 2005	
	STANDARD: JEDEC MS-012AA		

PAGE 1 OF 2

## CASE 751-07 ISSUE U 8-LEAD SOIC PACKAGE

## PACKAGE DIMENSIONS

### NOTES:

1. DIMENSIONS ARE IN MILLIMETERS.
2. DIMENSIONING AND TOLERANCING PER ASME Y14.5M-1994.
3. DIMENSION DOES NOT INCLUDE MOLD PROTRUSION. MAXIMUM MOLD PROTRUSION 0.15 PER SIDE.
4. DIMENSION DOES NOT INCLUDE DAMBAR PROTRUSION. ALLOWABLE DAMBAR PROTRUSION SHALL BE 0.127 TOTAL IN EXCESS OF THE DIMENSION AT MAXIMUM MATERIAL CONDITION.

© FREESCALE SEMICONDUCTOR, INC. ALL RIGHTS RESERVED.	MECHANICAL OUTLINE	PRINT VERSION NOT TO SCALE	
TITLE:  8LD SOIC NARROW BODY	DOCUMENT NO: 98ASB42564B	REV: U	
	CASE NUMBER: 751-07	07 APR 2005	
	STANDARD: JEDEC MS-012AA		

PAGE 2 OF 2

**CASE 751-07  
ISSUE U  
8-LEAD SOIC PACKAGE**

**MC100ES6011**



---

# NOTES

## **How to Reach Us:**

### **Home Page:**

www.freescale.com

### **E-mail:**

support@freescale.com

### **USA/Europe or Locations Not Listed:**

Freescale Semiconductor  
Technical Information Center, CH370  
1300 N. Alma School Road  
Chandler, Arizona 85224  
+1-800-521-6274 or +1-480-768-2130  
support@freescale.com

### **Europe, Middle East, and Africa:**

Freescale Halbleiter Deutschland GmbH  
Technical Information Center  
Schatzbogen 7  
81829 Muenchen, Germany  
+44 1296 380 456 (English)  
+46 8 52200080 (English)  
+49 89 92103 559 (German)  
+33 1 69 35 48 48 (French)  
support@freescale.com

### **Japan:**

Freescale Semiconductor Japan Ltd.  
Headquarters  
ARCO Tower 15F  
1-8-1, Shimo-Meguro, Meguro-ku,  
Tokyo 153-0064  
Japan  
0120 191014 or +81 3 5437 9125  
support.japan@freescale.com

### **Asia/Pacific:**

Freescale Semiconductor Hong Kong Ltd.  
Technical Information Center  
2 Dai King Street  
Tai Po Industrial Estate  
Tai Po, N.T., Hong Kong  
+800 2666 8080  
support.asia@freescale.com

### **For Literature Requests Only:**

Freescale Semiconductor Literature Distribution Center  
P.O. Box 5405  
Denver, Colorado 80217  
1-800-441-2447 or 303-675-2140  
Fax: 303-675-2150  
LDCForFreescaleSemiconductor@hibbertgroup.com

Information in this document is provided solely to enable system and software implementers to use Freescale Semiconductor products. There are no express or implied copyright licenses granted hereunder to design or fabricate any integrated circuits or integrated circuits based on the information in this document.

Freescale Semiconductor reserves the right to make changes without further notice to any products herein. Freescale Semiconductor makes no warranty, representation or guarantee regarding the suitability of its products for any particular purpose, nor does Freescale Semiconductor assume any liability arising out of the application or use of any product or circuit, and specifically disclaims any and all liability, including without limitation consequential or incidental damages. "Typical" parameters that may be provided in Freescale Semiconductor data sheets and/or specifications can and do vary in different applications and actual performance may vary over time. All operating parameters, including "Typicals", must be validated for each customer application by customer's technical experts. Freescale Semiconductor does not convey any license under its patent rights nor the rights of others. Freescale Semiconductor products are not designed, intended, or authorized for use as components in systems intended for surgical implant into the body, or other applications intended to support or sustain life, or for any other application in which the failure of the Freescale Semiconductor product could create a situation where personal injury or death may occur. Should Buyer purchase or use Freescale Semiconductor products for any such unintended or unauthorized application, Buyer shall indemnify and hold Freescale Semiconductor and its officers, employees, subsidiaries, affiliates, and distributors harmless against all claims, costs, damages, and expenses, and reasonable attorney fees arising out of, directly or indirectly, any claim of personal injury or death associated with such unintended or unauthorized use, even if such claim alleges that Freescale Semiconductor was negligent regarding the design or manufacture of the part.

Freescale™ and the Freescale logo are trademarks of Freescale Semiconductor, Inc. All other product or service names are the property of their respective owners.

© Freescale Semiconductor, Inc. 2005. All rights reserved.



## Looking for pricing, stock, or lifecycle information?

Click below to explore more details on WIN SOURCE:

- ⊖ [View MC100ES6011D on WIN SOURCE](#)
- ⊖ [Freescale Semiconductor - NXP Information](#)

## Optimize Your Supply Chain with WIN SOURCE Solutions

- ✓ Global Sourcing Solution
- ✓ Obsolete Management
- ✓ Cost Control Management
- ✓ Shortage Management
- ✓ Alternative Solution
- ✓ Excess Inventory Management