

MC100E241

5V ECL 8-Bit Scannable Register

Description

The MC100E241 is an 8-bit shiftable register. Unlike a standard universal shift register such as the E141, the E241 features internal data feedback organized so that the SHIFT control overrides the HOLD/ $\overline{\text{LOAD}}$ control. This enables the normal operations of HOLD and LOAD to be toggled with a single control line without the need for external gating. It also enables switching to scan mode with the single SHIFT control line.

The eight inputs $D_0 - D_7$ accept parallel input data, while S-IN accepts serial input data when in shift mode. Data is accepted a set-up time before the positive-going edge of CLK; shifting is also accomplished on the positive clock edge. A HIGH on the Master Reset pin (MR) asynchronously resets all the registers to zero.

The 100 Series contains temperature compensation.

Features

- SHIFT overrides HOLD/ $\overline{\text{LOAD}}$ Control
 - 1000 ps Max. CLK to Q
 - Asynchronous Master Reset
 - Pin-Compatible with E141
 - PECL Mode Operating Range: $V_{CC} = 4.2 \text{ V}$ to 5.7 V with $V_{EE} = 0 \text{ V}$
 - NECL Mode Operating Range: $V_{CC} = 0 \text{ V}$ with $V_{EE} = -4.2 \text{ V}$ to -5.7 V
 - Internal Input 50 k Ω Pulldown Resistors
 - ESD Protection: Human Body Model; > 1 kV, Machine Model; > 75 V
 - Meets or Exceeds JEDEC Spec EIA/JESD78 IC Latchup Test
 - Moisture Sensitivity Level:
Pb = 1
Pb-Free = 3
- For Additional Information, see Application Note AND8003/D
- Flammability Rating: UL 94 V-0 @ 0.125 in, Oxygen Index: 28 to 34
 - Transistor Count = 529 devices
 - Pb-Free Packages are Available*



ON Semiconductor®

<http://onsemi.com>

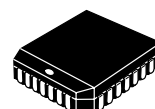

PLCC-28
FN SUFFIX
CASE 776

MARKING DIAGRAM*

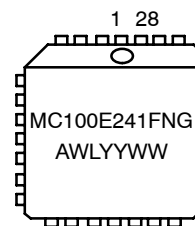

A = Assembly Location
WL = Wafer Lot
YY = Year
WW = Work Week
G = Pb-Free Package

*For additional marking information, refer to Application Note AND8002/D.

ORDERING INFORMATION

See detailed ordering and shipping information in the package dimensions section on page 5 of this data sheet.

*For additional information on our Pb-Free strategy and soldering details, please download the ON Semiconductor Soldering and Mounting Techniques Reference Manual, SOLDERRM/D.

MC100E241

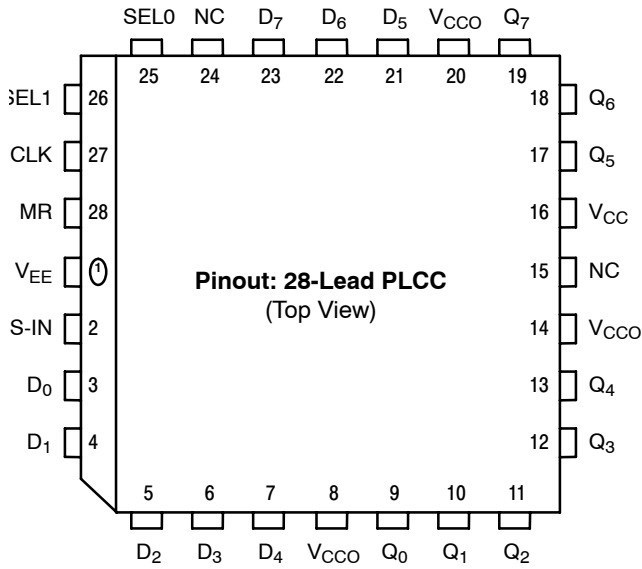

**Pinout: 28-Lead PLCC
(Top View)**

* All V_{CC} and V_{CCO} pins are tied together on the die.

Warning: All V_{CC}, V_{CCO}, and V_{EE} pins must be externally connected to Power Supply to guarantee proper operation.

Figure 1. Pinout Assignment

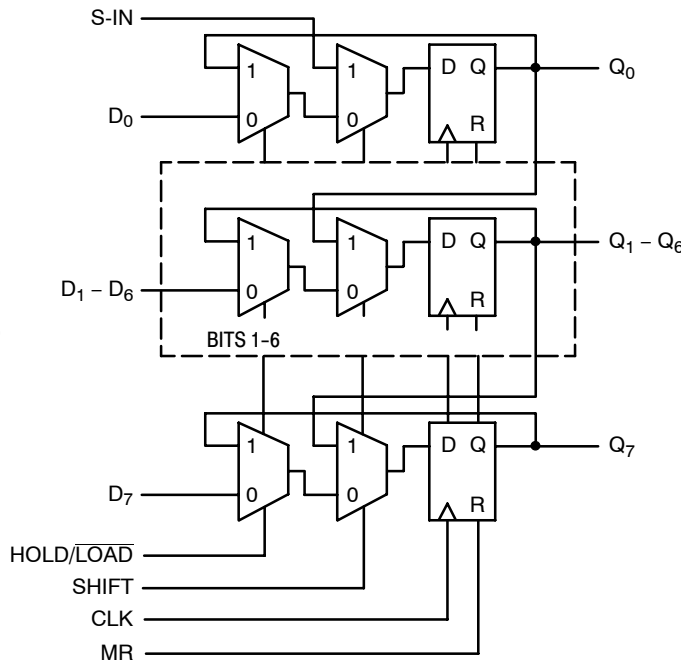

Figure 2. Logic Diagram

Table 1. PIN DESCRIPTION

PIN	FUNCTION
D ₀ - D ₇	ECL Parallel Data Inputs
S-IN	ECL Serial Data Inputs
SEL0	ECL SHIFT Control
SEL1	ECL HOLD/LOAD Control
CLK	ECL Clock
MR	ECL Master Reset
Q ₀ - Q ₇	ECL Data Outputs
V _{CC} , V _{CCO}	Positive Supply
V _{EE}	Negative Supply
NC	No Connect

Table 2. FUNCTION TABLE

MR	SEL0	SEL1	Function
1	X	X	Outputs LOW
0	1	X	Shift Data
0	0	1	Hold Data
0	0	0	Load Data

X = Don't Care

MC100E241

Table 3. MAXIMUM RATINGS

Symbol	Parameter	Condition 1	Condition 2	Rating	Unit
V _{CC}	PECL Mode Power Supply	V _{EE} = 0 V		8	V
V _{EE}	NECL Mode Power Supply	V _{CC} = 0 V		-8	V
V _I	PECL Mode Input Voltage NECL Mode Input Voltage	V _{EE} = 0 V V _{CC} = 0 V	V _I ≤ V _{CC} V _I ≥ V _{EE}	6 -6	V V
I _{out}	Output Current	Continuous Surge		50 100	mA mA
T _A	Operating Temperature Range			0 to +85	°C
T _{stg}	Storage Temperature Range			-65 to +150	°C
θ _{JA}	Thermal Resistance (Junction-to-Ambient)	0 lfpm 500 lfpm	PLCC-28 PLCC-28	63.5 43.5	°C/W °C/W
θ _{JC}	Thermal Resistance (Junction-to-Case)	Standard Board	PLCC-28	22 to 26	°C/W
T _{sol}	Wave Solder Pb Pb-Free			265 265	°C

Stresses exceeding Maximum Ratings may damage the device. Maximum Ratings are stress ratings only. Functional operation above the Recommended Operating Conditions is not implied. Extended exposure to stresses above the Recommended Operating Conditions may affect device reliability.

Table 4. 100E SERIES PECL DC CHARACTERISTICS V_{CCx} = 5.0 V, V_{EE} = 0.0 V (Note 1)

Symbol	Characteristic	0°C			25°C			85°C			Unit
		Min	Typ	Max	Min	Typ	Max	Min	Typ	Max	
I _{EE}	Power Supply Current		125	150		125	150		144	173	mA
V _{OH}	Output HIGH Voltage (Note 2)	3975	4050	4120	3975	4050	4120	3975	4050	4120	mV
V _{OL}	Output LOW Voltage (Note 2)	3190	3295	3380	3190	3255	3380	3190	3260	3380	mV
V _{IH}	Input HIGH Voltage	3835	3975	4120	3835	3975	4120	3835	3975	4120	mV
V _{IL}	Input LOW Voltage	3190	3355	3525	3190	3355	3525	3190	3355	3525	mV
I _{IH}	Input HIGH Current			150			150			150	μA
I _{IL}	Input LOW Current	0.5	0.3		0.5	0.25		0.5	0.2		μA

NOTE: Device will meet the specifications after thermal equilibrium has been established when mounted in a test socket or printed circuit board with maintained transverse airflow greater than 500 lfpm. Electrical parameters are guaranteed only over the declared operating temperature range. Functional operation of the device exceeding these conditions is not implied. Device specification limit values are applied individually under normal operating conditions and not valid simultaneously.

1. Input and output parameters vary 1:1 with V_{CC}. V_{EE} can vary -0.46 V / +0.8 V.
2. Outputs are terminated through a 50 Ω resistor to V_{CC} - 2.0 V.

Table 5. 100E SERIES NECL DC CHARACTERISTICS V_{CCx} = 0.0 V; V_{EE} = -5.0 V (Note 3)

Symbol	Characteristic	0°C			25°C			85°C			Unit
		Min	Typ	Max	Min	Typ	Max	Min	Typ	Max	
I _{EE}	Power Supply Current		125	150		125	150		144	173	mA
V _{OH}	Output HIGH Voltage	-1025	-950	-880	-1025	-950	-880	-1025	-950	-880	mV
V _{OL}	Output LOW Voltage	-1810	-1705	-1620	-1810	-1745	-1620	-1810	-1740	-1620	mV
V _{IH}	Input HIGH Voltage (Single-Ended)	-1165	-1025	-880	-1165	-1025	-880	-1165	-1025	-880	mV
V _{IL}	Input LOW Voltage (Single-Ended)	-1810	-1645	-1475	-1810	-1645	-1475	-1810	-1645	-1475	mV
I _{IH}	Input HIGH Current			150			150			150	μA
I _{IL}	Input LOW Current	0.5	0.3		0.5	0.25		0.5	0.2		μA

NOTE: Device will meet the specifications after thermal equilibrium has been established when mounted in a test socket or printed circuit board with maintained transverse airflow greater than 500 lfpm. Electrical parameters are guaranteed only over the declared operating temperature range. Functional operation of the device exceeding these conditions is not implied. Device specification limit values are applied individually under normal operating conditions and not valid simultaneously.

3. Input and output parameters vary 1:1 with V_{CC}. V_{EE} can vary -0.46 V / +0.8 V.
4. Outputs are terminated through a 50 Ω resistor to V_{CC} - 2.0 V.

MC100E241

Table 6. AC CHARACTERISTICS $V_{CCx} = 5.0\text{ V}$; $V_{EE} = 0.0\text{ V}$ or $V_{CCx} = 0.0\text{ V}$; $V_{EE} = -5.0\text{ V}$ (Note 5)

Symbol	Characteristic	0°C			25°C			85°C			Unit
		Min	Typ	Max	Min	Typ	Max	Min	Typ	Max	
f _{MAX}	Maximum Toggle Frequency		900			900			900		GHz
f _{SHIFT}	Max. Shift Frequency	700	900		700	900		700	900		MHz
t _{PLH} t _{PHL}	Propagation Delay to Output CLK MR	625 600	750 725	975 975	625 600	750 725	975 975	625 600	750 725	975 975	ps
t _s	Setup Time D SEL0 (SHIFT) SEL1 (HOLD/ $\overline{\text{LOAD}}$) S-IN	175 350 400 125	25 200 250 -100		175 350 400 125	25 200 250 -100		175 350 400 125	25 200 250 -100		ps
t _h	Hold Time D SEL0 (SHIFT) SEL1 (HOLD/ $\overline{\text{LOAD}}$) S-IN	200 100 50 300	-25 -200 -250 100		200 100 50 300	-25 -200 -250 100		200 100 50 300	-25 -200 -250 100		ps
t _{RR}	Reset Recovery Time	900	600		900	600		900	600		ps
t _{PW}	Minimum Pulse Width CLK, MR	400			400			400			ps
t _{SKEW}	Within-Device Skew (Note 6)		60			60			60		ps
t _{JITTER}	Random Clock Jitter (RMS)		< 1			< 1			< 1		ps
t _r t _f	Rise/Fall Times (20 - 80%)	300	525	800	300	525	800	300	525	800	ps

NOTE: Device will meet the specifications after thermal equilibrium has been established when mounted in a test socket or printed circuit board with maintained transverse airflow greater than 500 lpm. Electrical parameters are guaranteed only over the declared operating temperature range. Functional operation of the device exceeding these conditions is not implied. Device specification limit values are applied individually under normal operating conditions and not valid simultaneously.

5. 100 Series: V_{EE} can vary $-0.46\text{ V} / +0.8\text{ V}$.

6. Within-device skew is defined as identical transitions on similar paths through a device.

MC100E241

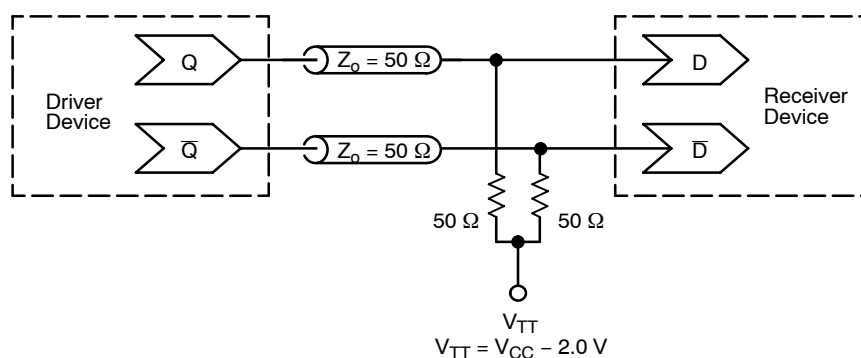

Figure 3. Typical Termination for Output Driver and Device Evaluation
(See Application Note AND8020/D – Termination of ECL Logic Devices.)

ORDERING INFORMATION

Device	Package	Shipping [†]
MC100E241FN	PLCC-28	37 Units / Rail
MC100E241FNG	PLCC-28 (Pb-Free)	37 Units / Rail
MC100E241FNR2	PLCC-28	500 / Tape & Reel
MC100E241FNR2G	PLCC-28 (Pb-Free)	500 / Tape & Reel

[†]For information on tape and reel specifications, including part orientation and tape sizes, please refer to our Tape and Reel Packaging Specifications Brochure, BRD8011/D.

Resource Reference of Application Notes

- AN1405/D** – ECL Clock Distribution Techniques
- AN1406/D** – Designing with PECL (ECL at +5.0 V)
- AN1503/D** – ECLinPS™ I/O SPiCE Modeling Kit
- AN1504/D** – Metastability and the ECLinPS Family
- AN1568/D** – Interfacing Between LVDS and ECL
- AN1672/D** – The ECL Translator Guide
- AND8001/D** – Odd Number Counters Design
- AND8002/D** – Marking and Date Codes
- AND8020/D** – Termination of ECL Logic Devices
- AND8066/D** – Interfacing with ECLinPS
- AND8090/D** – AC Characteristics of ECL Devices

MC100E241

PACKAGE DIMENSIONS

PLCC-28
FN SUFFIX
PLASTIC PLCC PACKAGE
CASE 776-02
ISSUE E

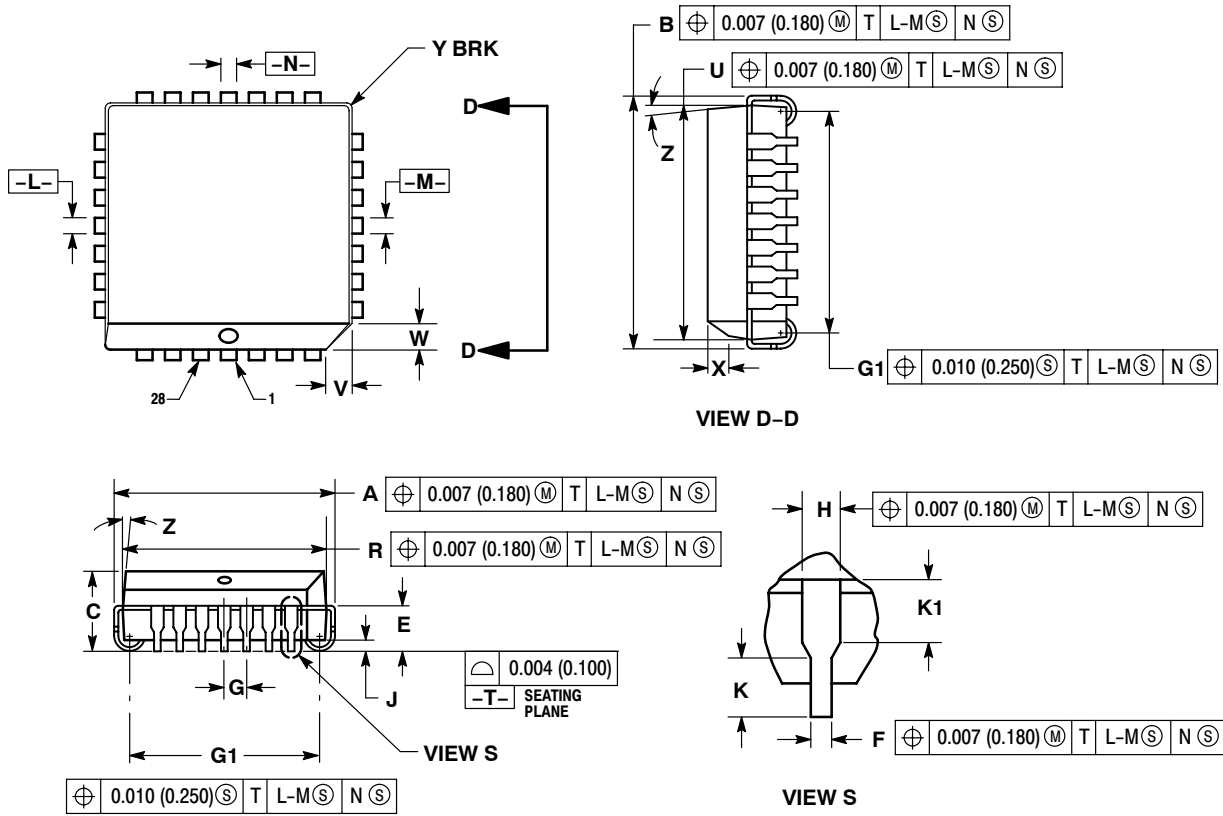

NOTES:

- DATUMS -L-, -M-, AND -N- DETERMINED WHERE TOP OF LEAD SHOULDER EXITS PLASTIC BODY AT MOLD PARTING LINE.
- DIMENSION G1, TRUE POSITION TO BE MEASURED AT DATUM -T-, SEATING PLANE.
- DIMENSIONS R AND U DO NOT INCLUDE MOLD FLASH. ALLOWABLE MOLD FLASH IS 0.010 (0.250) PER SIDE.
- DIMENSIONING AND TOLERANCING PER ANSI Y14.5M, 1982.
- CONTROLLING DIMENSION: INCH.
- THE PACKAGE TOP MAY BE SMALLER THAN THE PACKAGE BOTTOM BY UP TO 0.012 (0.300). DIMENSIONS R AND U ARE DETERMINED AT THE OUTERMOST EXTREMES OF THE PLASTIC BODY EXCLUSIVE OF MOLD FLASH, TIE BAR BURRS, GATE BURRS AND INTERLEAD FLASH, BUT INCLUDING ANY MISMATCH BETWEEN THE TOP AND BOTTOM OF THE PLASTIC BODY.
- DIMENSION H DOES NOT INCLUDE DAMBAR PROTRUSION OR INTRUSION. THE DAMBAR PROTRUSION(S) SHALL NOT CAUSE THE H DIMENSION TO BE GREATER THAN 0.037 (0.940). THE DAMBAR INTRUSION(S) SHALL NOT CAUSE THE H DIMENSION TO BE SMALLER THAN 0.025 (0.635).

DIM	INCHES		MILLIMETERS	
	MIN	MAX	MIN	MAX
A	0.485	0.495	12.32	12.57
B	0.485	0.495	12.32	12.57
C	0.165	0.180	4.20	4.57
E	0.090	0.110	2.29	2.79
F	0.013	0.019	0.33	0.48
G	0.050 BSC		1.27 BSC	
H	0.026	0.032	0.66	0.81
J	0.020	---	0.51	---
K	0.025	---	0.64	---
R	0.450	0.456	11.43	11.58
U	0.450	0.456	11.43	11.58
V	0.042	0.048	1.07	1.21
W	0.042	0.048	1.07	1.21
X	0.042	0.056	1.07	1.42
Y	---	0.020	---	0.50
Z	2° 10°		2° 10°	
G1	0.410	0.430	10.42	10.92
K1	0.040	---	1.02	---

ECLinPS is a trademark of Semiconductor Components Industries, LLC (SCILLC).

ON Semiconductor and  are registered trademarks of Semiconductor Components Industries, LLC (SCILLC). SCILLC reserves the right to make changes without further notice to any products herein. SCILLC makes no warranty, representation or guarantee regarding the suitability of its products for any particular purpose, nor does SCILLC assume any liability arising out of the application or use of any product or circuit, and specifically disclaims any and all liability, including without limitation special, consequential or incidental damages. "Typical" parameters which may be provided in SCILLC data sheets and/or specifications can and do vary in different applications and actual performance may vary over time. All operating parameters, including "Typicals" must be validated for each customer application by customer's technical experts. SCILLC does not convey any license under its patent rights nor the rights of others. SCILLC products are not designed, intended, or authorized for use as components in systems intended for surgical implant into the body, or other applications intended to support or sustain life, or for any other application in which the failure of the SCILLC product could create a situation where personal injury or death may occur. Should Buyer purchase or use SCILLC products for any such unintended or unauthorized application, Buyer shall indemnify and hold SCILLC and its officers, employees, subsidiaries, affiliates, and distributors harmless against all claims, costs, damages, and expenses, and reasonable attorney fees arising out of, directly or indirectly, any claim of personal injury or death associated with such unintended or unauthorized use, even if such claim alleges that SCILLC was negligent regarding the design or manufacture of the part. SCILLC is an Equal Opportunity/Affirmative Action Employer. This literature is subject to all applicable copyright laws and is not for resale in any manner.

PUBLICATION ORDERING INFORMATION

LITERATURE FULFILLMENT:

Literature Distribution Center for ON Semiconductor
P.O. Box 5163, Denver, Colorado 80217 USA
Phone: 303-675-2175 or 800-344-3860 Toll Free USA/Canada
Fax: 303-675-2176 or 800-344-3867 Toll Free USA/Canada
Email: orderlit@onsemi.com

N. American Technical Support: 800-282-9855 Toll Free
USA/Canada
Europe, Middle East and Africa Technical Support:
Phone: 421 33 790 2910
Japan Customer Focus Center
Phone: 81-3-5773-3850

ON Semiconductor Website: www.onsemi.com
Order Literature: <http://www.onsemi.com/orderlit>
For additional information, please contact your local
Sales Representative

Looking for pricing, stock, or lifecycle information?

Click below to explore more details on WIN SOURCE:

- ⊖ [View MC100E241FNR2 on WIN SOURCE](#)
- ⊖ [ON Semiconductor](#) Information

Optimize Your Supply Chain with WIN SOURCE Solutions

- ✓ Global Sourcing Solution
- ✓ Obsolete Management
- ✓ Cost Control Management
- ✓ Shortage Management
- ✓ Alternative Solution
- ✓ Excess Inventory Management