



**THE DATASHEET OF
MC100E151FNG**



MC10E151, MC100E151

5 V ECL 6-Bit D Register

Description

The MC10E/100E151 contains 6 D-type, edge-triggered, master-slave flip-flops with differential outputs. Data enters the master when both CLK1 and CLK2 are LOW, and is transferred to the slave when CLK1 or CLK2 (or both) go HIGH. The asynchronous Master Reset (MR) makes all Q outputs go LOW.

The 100 Series contains temperature compensation.

Features

- 1100 MHz Min. Toggle Frequency
- Differential Outputs
- Asynchronous Master Reset
- Dual Clocks
- PECL Mode Operating Range:
 - ◆ $V_{CC} = 4.2\text{ V to }5.7\text{ V}$ with $V_{EE} = 0\text{ V}$
- NECL Mode Operating Range:
 - ◆ $V_{CC} = 0\text{ V}$ with $V_{EE} = -4.2\text{ V to }-5.7\text{ V}$
- Internal Input 50 k Ω Pulldown Resistors
- ESD Protection:
 - ◆ Human Body Model; > 2 kV
 - ◆ Machine Model; > 200 V
- Meets or Exceeds JEDEC Standard EIA/JESD78 IC Latchup Test
- Moisture Sensitivity Level: 3 (Pb-Free)
 - ◆ For Additional Information, see Application Note [AND8003/D](#)
- Flammability Rating: UL 94 V-0 @ 0.125 in, Oxygen Index: 28 to 34
- Transistor Count = 304 devices
- These Devices are Pb-Free, Halogen Free and are RoHS Compliant



ON Semiconductor®

www.onsemi.com

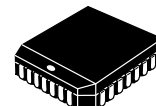

PLCC-28
FN SUFFIX
CASE 776-02

MARKING DIAGRAM*

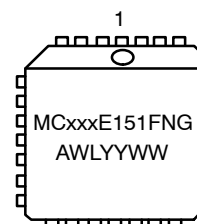

xxx = 10 or 100
A = Assembly Location
WL = Wafer Lot
YY = Year
WW = Work Week
G = Pb-Free Package

*For additional marking information, refer to Application Note [AND8002/D](#).

ORDERING INFORMATION

| Device | Package | Shipping† |
|---------------|----------------------|-----------------|
| MC10E151FNG | PLCC-28 (Pb-Free) | 37 Units/Tube |
| MC10E151FNR2G | PLCC-28 (Pb-Free) | 500/Tape & Reel |
| MC100E151FNG | PLCC-28 (Pb-Free) | 37 Units/Tube |

†For information on tape and reel specifications, including part orientation and tape sizes, please refer to our Tape and Reel Packaging Specifications Brochure, [BRD8011/D](#).

MC10E151, MC100E151

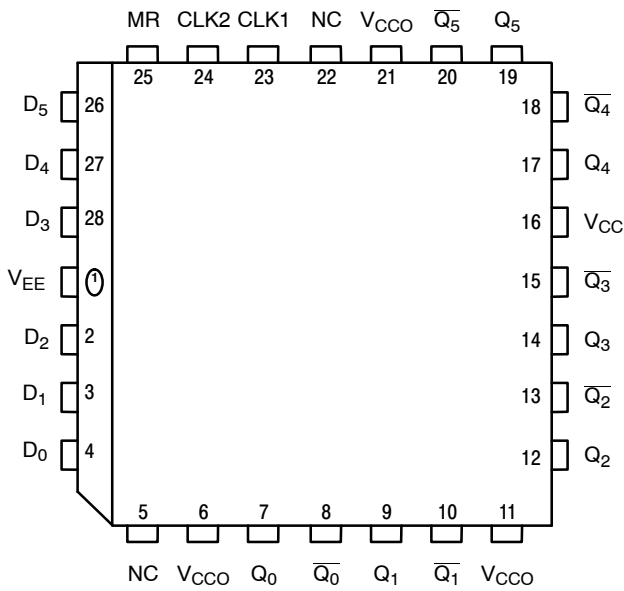

Table 1. PIN DESCRIPTION

| PIN | FUNCTION |
|---|--------------------------|
| D ₀ - D ₅ | ECL Data Inputs |
| CLK1, CLK2 | ECL Clock Inputs |
| MR | ECL Master Reset |
| Q ₀ - Q ₅ , Q ₀ ⁻ - Q ₅ ⁻ | ECL Differential Outputs |
| V _{CC} , V _{CCO} | Positive Supply |
| V _{EE} | Negative Supply |
| NC | No Connect |

* All V_{CC} and V_{CCO} pins are tied together on the die.

Warning: All V_{CC}, V_{CCO}, and V_{EE} pins must be externally connected to Power Supply to guarantee proper operation.

Figure 1. Pinout: PLCC-28 (Top View)

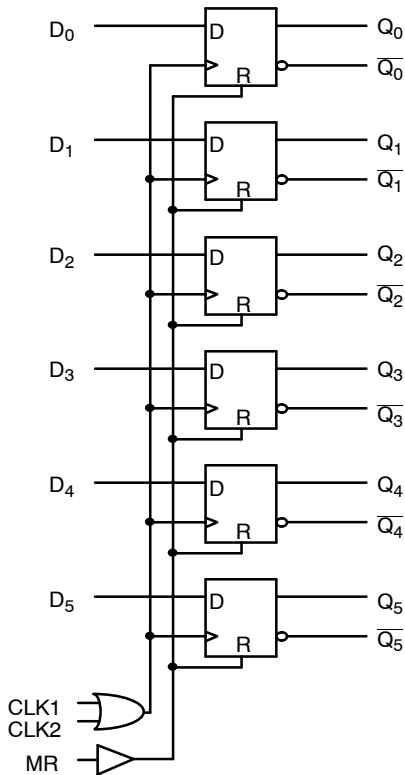

Figure 2. Logic Diagram

Table 2. FUNCTION TABLE

| MR | | Q _n |
|----|-------------|----------------|
| 1 | Reset | L |
| 0 | Operational | H |

MC10E151, MC100E151

Table 3. MAXIMUM RATINGS

| Symbol | Parameter | Condition 1 | Condition 2 | Rating | Unit |
|------------------|--|--|--|----------------------------|------|
| V _{CC} | PECL Mode Power Supply | V _{EE} = 0 V | | 8 | V |
| V _{EE} | NECL Mode Power Supply | V _{CC} = 0 V | | -8 | V |
| V _I | PECL Mode Input Voltage NECL Mode Input Voltage | V _{EE} = 0 V V _{CC} = 0 V | V _I ≤ V _{CC} V _I ≥ V _{EE} | 6 -6 | V |
| I _{out} | Output Current | Continuous Surge | | 50 100 | mA |
| T _A | Operating Temperature Range | | | 0 to +85 | °C |
| T _{stg} | Storage Temperature Range | | | -65 to +150 | °C |
| θ _{JA} | Thermal Resistance (Junction-to-Ambient) | 0 lfp 500 lfp | PLCC-28 | 63.5 43.5 | °C/W |
| θ _{JC} | Thermal Resistance (Junction-to-Case) | Standard Board | PLCC-28 | 22 to 26 | °C/W |
| V _{EE} | PECL Operating Range NECL Operating Range | | | 4.2 to 5.7 -5.7 to -4.2 | V |
| T _{sol} | Wave Solder (Pb-Free) | | | 265 | °C |

Stresses exceeding those listed in the Maximum Ratings table may damage the device. If any of these limits are exceeded, device functionality should not be assumed, damage may occur and reliability may be affected.

Table 4. 10E SERIES PECL DC CHARACTERISTICS (V_{CC} = 5.0 V, V_{EE} = 0.0 V (Note 1))

| Symbol | Characteristic | 0°C | | | 25°C | | | 85°C | | | Unit |
|-----------------|------------------------------|------|------|------|------|------|------|------|------|------|------|
| | | Min | Typ | Max | Min | Typ | Max | Min | Typ | Max | |
| I _{EE} | Power Supply Current | | | | | | | | | | mA |
| V _{OH} | Output HIGH Voltage (Note 2) | 3980 | 4070 | 4160 | 4020 | 4105 | 4190 | 4090 | 4185 | 4280 | mV |
| V _{OL} | Output LOW Voltage (Note 2) | 3050 | 3210 | 3370 | 3050 | 3210 | 3370 | 3050 | 3227 | 3405 | mV |
| V _{IH} | Input HIGH Voltage | 3830 | 3995 | 4160 | 3870 | 4030 | 4190 | 3940 | 4110 | 4280 | mV |
| V _{IL} | Input LOW Voltage | 3050 | 3285 | 3520 | 3050 | 3285 | 3520 | 3050 | 3302 | 3555 | mV |
| I _{IH} | Input HIGH Current | | | | | | | | | | μA |
| I _{IL} | Input LOW Current | 0.5 | 0.3 | | 0.5 | 0.25 | | 0.3 | 0.2 | | μA |

NOTE: Device will meet the specifications after thermal equilibrium has been established when mounted in a test socket or printed circuit board with maintained transverse airflow greater than 500 lfp. Electrical parameters are guaranteed only over the declared operating temperature range. Functional operation of the device exceeding these conditions is not implied. Device specification limit values are applied individually under normal operating conditions and not valid simultaneously.

1. Input and output parameters vary 1:1 with V_{CC}. V_{EE} can vary -0.46 V / +0.06 V.
2. Outputs are terminated through a 50 Ω resistor to V_{CC} - 2.0 V.

MC10E151, MC100E151

Table 5. 10E SERIES NECL DC CHARACTERISTICS ($V_{CCx} = 0.0\text{ V}$; $V_{EE} = -5.0\text{ V}$ (Note 1))

| Symbol | Characteristic | 0°C | | | 25°C | | | 85°C | | | Unit |
|----------|------------------------------|-------|-------|-------|-------|-------|-------|-------|-------|-------|---------------|
| | | Min | Typ | Max | Min | Typ | Max | Min | Typ | Max | |
| I_{EE} | Power Supply Current | | | | | | | | | | mA |
| V_{OH} | Output HIGH Voltage (Note 2) | -1020 | -930 | -840 | -980 | -895 | -810 | -910 | -815 | -720 | mV |
| V_{OL} | Output LOW Voltage (Note 2) | -1950 | -1790 | -1630 | -1950 | -1790 | -1630 | -1950 | -1773 | -1595 | mV |
| V_{IH} | Input HIGH Voltage | -1170 | -1005 | -840 | -1130 | -970 | -810 | -1060 | -890 | -720 | mV |
| V_{IL} | Input LOW Voltage | -1950 | -1715 | -1480 | -1950 | -1715 | -1480 | -1950 | -1698 | -1445 | mV |
| I_{IH} | Input HIGH Current | | | | | | | | | | μA |
| I_{IL} | Input LOW Current | 0.5 | 0.3 | | 0.5 | 0.065 | | 0.3 | 0.2 | | μA |

NOTE: Device will meet the specifications after thermal equilibrium has been established when mounted in a test socket or printed circuit board with maintained transverse airflow greater than 500 lfm. Electrical parameters are guaranteed only over the declared operating temperature range. Functional operation of the device exceeding these conditions is not implied. Device specification limit values are applied individually under normal operating conditions and not valid simultaneously.

1. Input and output parameters vary 1:1 with V_{CC} . V_{EE} can vary $-0.46\text{ V} / +0.06\text{ V}$.
2. Outputs are terminated through a $50\ \Omega$ resistor to $V_{CC} - 2.0\text{ V}$.

Table 6. 100E SERIES PECL DC CHARACTERISTICS ($V_{CCx} = 5.0\text{ V}$; $V_{EE} = 0.0\text{ V}$ (Note 1))

| Symbol | Characteristic | 0°C | | | 25°C | | | 85°C | | | Unit |
|----------|------------------------------|------|------|------|------|------|------|------|------|------|---------------|
| | | Min | Typ | Max | Min | Typ | Max | Min | Typ | Max | |
| I_{EE} | Power Supply Current | | 65 | 78 | | 65 | 78 | | 75 | 90 | mA |
| V_{OH} | Output HIGH Voltage (Note 2) | 3975 | 4050 | 4120 | 3975 | 4050 | 4120 | 3975 | 4050 | 4120 | mV |
| V_{OL} | Output LOW Voltage (Note 2) | 3190 | 3295 | 3380 | 3190 | 3255 | 3380 | 3190 | 3260 | 3380 | mV |
| V_{IH} | Input HIGH Voltage | 3835 | 3975 | 4120 | 3835 | 3975 | 4120 | 3835 | 3975 | 4120 | mV |
| V_{IL} | Input LOW Voltage | 3190 | 3355 | 3525 | 3190 | 3355 | 3525 | 3190 | 3355 | 3525 | mV |
| I_{IH} | Input HIGH Current | | | 150 | | | 150 | | | 150 | μA |
| I_{IL} | Input LOW Current | 0.5 | 0.3 | | 0.5 | 0.25 | | 0.5 | 0.2 | | μA |

NOTE: Device will meet the specifications after thermal equilibrium has been established when mounted in a test socket or printed circuit board with maintained transverse airflow greater than 500 lfm. Electrical parameters are guaranteed only over the declared operating temperature range. Functional operation of the device exceeding these conditions is not implied. Device specification limit values are applied individually under normal operating conditions and not valid simultaneously.

1. Input and output parameters vary 1:1 with V_{CC} . V_{EE} can vary $-0.46\text{ V} / +0.8\text{ V}$.
2. Outputs are terminated through a $50\ \Omega$ resistor to $V_{CC} - 2\text{ volts}$.

Table 7. 100E SERIES NECL DC CHARACTERISTICS ($V_{CCx} = 0.0\text{ V}$; $V_{EE} = -5.0\text{ V}$ (Note 1))

| Symbol | Characteristic | 0°C | | | 25°C | | | 85°C | | | Unit |
|----------|------------------------------|-------|-------|-------|-------|-------|-------|-------|-------|-------|---------------|
| | | Min | Typ | Max | Min | Typ | Max | Min | Typ | Max | |
| I_{EE} | Power Supply Current | | 65 | 78 | | 65 | 78 | | 75 | 90 | mA |
| V_{OH} | Output HIGH Voltage (Note 2) | -1025 | -950 | -880 | -1025 | -950 | -880 | -1025 | -950 | -880 | mV |
| V_{OL} | Output LOW Voltage (Note 2) | -1810 | -1705 | -1620 | -1810 | -1745 | -1620 | -1810 | -1740 | -1620 | mV |
| V_{IH} | Input HIGH Voltage | -1165 | -1025 | -880 | -1165 | -1025 | -880 | -1165 | -1025 | -880 | mV |
| V_{IL} | Input LOW Voltage | -1810 | -1645 | -1475 | -1810 | -1645 | -1475 | -1810 | -1645 | -1475 | mV |
| I_{IH} | Input HIGH Current | | | 150 | | | 150 | | | 150 | μA |
| I_{IL} | Input LOW Current | 0.5 | 0.3 | | 0.5 | 0.25 | | 0.5 | 0.2 | | μA |

NOTE: Device will meet the specifications after thermal equilibrium has been established when mounted in a test socket or printed circuit board with maintained transverse airflow greater than 500 lfm. Electrical parameters are guaranteed only over the declared operating temperature range. Functional operation of the device exceeding these conditions is not implied. Device specification limit values are applied individually under normal operating conditions and not valid simultaneously.

1. Input and output parameters vary 1:1 with V_{CC} . V_{EE} can vary $-0.46\text{ V} / +0.8\text{ V}$.
2. Outputs are terminated through a $50\ \Omega$ resistor to $V_{CC} - 2.0\text{ V}$.

MC10E151, MC100E151

Table 8. AC CHARACTERISTICS ($V_{CCx} = 5.0\text{ V}$; $V_{EE} = 0.0\text{ V}$ or $V_{CCx} = 0.0\text{ V}$; $V_{EE} = -5.0\text{ V}$ (Note 1))

| Symbol | Characteristic | 0°C | | | 25°C | | | 85°C | | | Unit |
|------------------------|--|-----|------|-----|------|------|-----|------|------|-----|------|
| | | Min | Typ | Max | Min | Typ | Max | Min | Typ | Max | |
| f_{MAX} | Maximum Toggle Frequency | 900 | 1100 | | 900 | 1100 | | 900 | 1100 | | MHz |
| T_{PLH} t_{PHL} | Propagation Delay to Output CLK, MR | 575 | 650 | 900 | 575 | 650 | 900 | 575 | 650 | 900 | ps |
| t_s | Setup Time D | 0 | -175 | | 0 | -175 | | 0 | -175 | | ps |
| t_h | Hold Time D | 350 | 175 | | 350 | 175 | | 350 | 175 | | ps |
| t_{RR} | Reset Recovery Time | 750 | 550 | | 750 | 550 | | 750 | 550 | | |
| t_{PW} | Minimum Pulse Width CLK, MR | 400 | | | 400 | | | 400 | | | ps |
| t_{SKEW} | Within-Device Skew (Note 2) | | 65 | | | 65 | | | 65 | | ps |
| t_{JITTER} | Random Clock Jitter (RMS) | | < 1 | | | < 1 | | | < 1 | | ps |
| t_r, t_f | Rise/Fall Times (20 - 80%) | 300 | 450 | 700 | 300 | 450 | 700 | 300 | 450 | 700 | ps |

NOTE: Device will meet the specifications after thermal equilibrium has been established when mounted in a test socket or printed circuit board with maintained transverse airflow greater than 500 lfm. Electrical parameters are guaranteed only over the declared operating temperature range. Functional operation of the device exceeding these conditions is not implied. Device specification limit values are applied individually under normal operating conditions and not valid simultaneously.

- 10 Series: V_{EE} can vary $-0.46\text{ V} / +0.06\text{ V}$.
100 Series: V_{EE} can vary $-0.46\text{ V} / +0.8\text{ V}$.
- Within-device skew is defined as identical transitions on similar paths through a device.

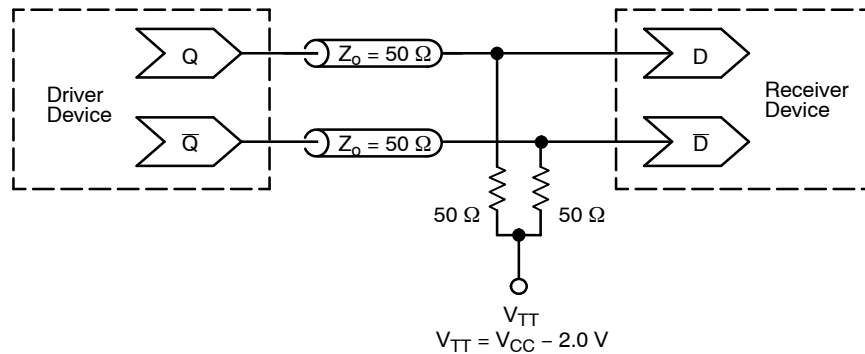

Figure 3. Typical Termination for Output Driver and Device Evaluation
(See Application Note [AND8020/D](#) – Termination of ECL Logic Devices.)

Resource Reference of Application Notes

- AN1405/D** – ECL Clock Distribution Techniques
- AN1406/D** – Designing with PECL (ECL at +5.0 V)
- AN1503/D** – ECLinPS™ I/O SPICE Modeling Kit
- AN1504/D** – Metastability and the ECLinPS Family
- AN1568/D** – Interfacing Between LVDS and ECL
- AN1672/D** – The ECL Translator Guide
- AND8001/D** – Odd Number Counters Design
- AND8002/D** – Marking and Date Codes
- AND8020/D** – Termination of ECL Logic Devices
- AND8066/D** – Interfacing with ECLinPS
- AND8090/D** – AC Characteristics of ECL Devices

MC10E151, MC100E151

PACKAGE DIMENSIONS

28 LEAD PLLC
CASE 776-02
ISSUE F

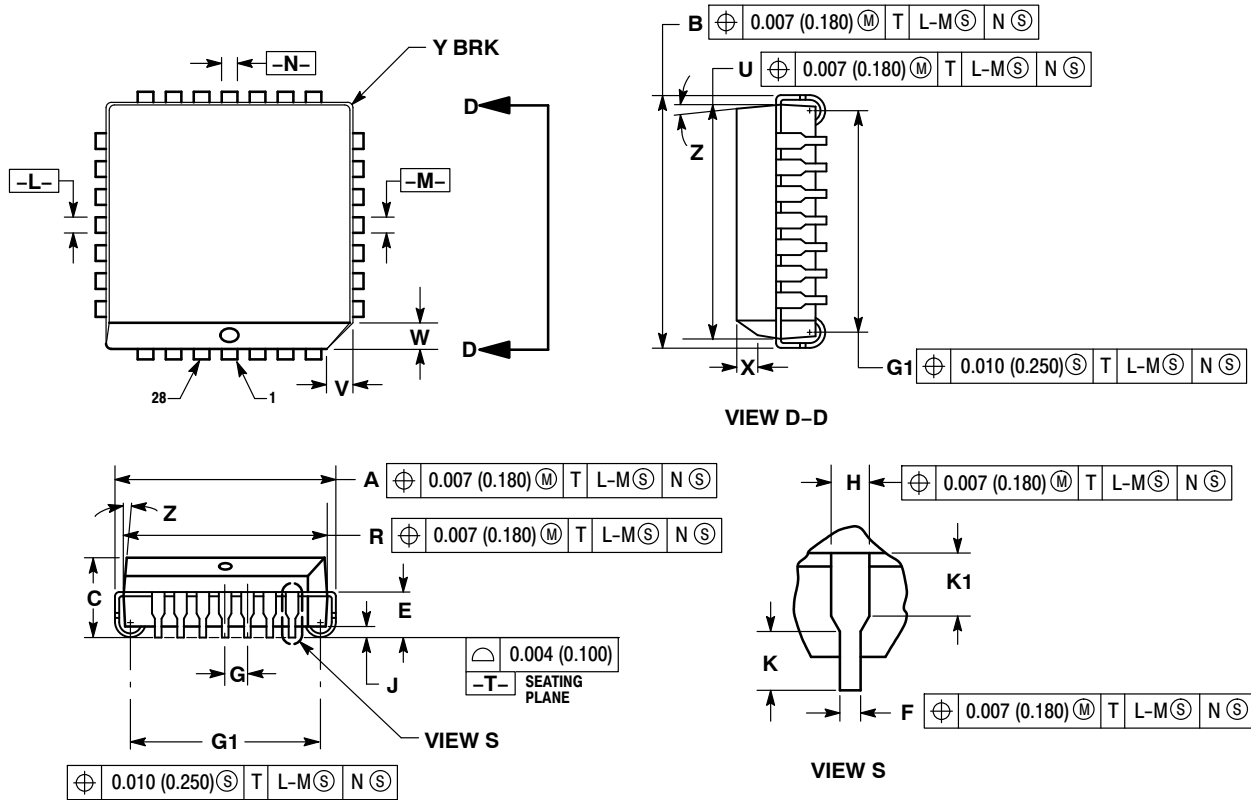

NOTES:

- DATUMS -L-, -M-, AND -N- DETERMINED WHERE TOP OF LEAD SHOULDER EXITS PLASTIC BODY AT MOLD PARTING LINE.
- DIMENSION G1. TRUE POSITION TO BE MEASURED AT DATUM -T-, SEATING PLANE.
- DIMENSIONS R AND U DO NOT INCLUDE MOLD FLASH. ALLOWABLE MOLD FLASH IS 0.010 (0.250) PER SIDE.
- DIMENSIONING AND TOLERANCING PER ANSI Y14.5M, 1982.
- CONTROLLING DIMENSION: INCH.
- THE PACKAGE TOP MAY BE SMALLER THAN THE PACKAGE BOTTOM BY UP TO 0.012 (0.300). DIMENSIONS R AND U ARE DETERMINED AT THE OUTERMOST EXTREMES OF THE PLASTIC BODY EXCLUSIVE OF MOLD FLASH, TIE BAR BURRS, GATE BURRS AND INTERLEAD FLASH, BUT INCLUDING ANY MISMATCH BETWEEN THE TOP AND BOTTOM OF THE PLASTIC BODY.
- DIMENSION H DOES NOT INCLUDE DAMBAR PROTRUSION OR INTRUSION. THE DAMBAR PROTRUSION(S) SHALL NOT CAUSE THE H DIMENSION TO BE GREATER THAN 0.037 (0.940). THE DAMBAR INTRUSION(S) SHALL NOT CAUSE THE H DIMENSION TO BE SMALLER THAN 0.025 (0.635).

| DIM | INCHES | | MILLIMETERS | |
|-----|-----------|-------|-------------|-------|
| | MIN | MAX | MIN | MAX |
| A | 0.485 | 0.495 | 12.32 | 12.57 |
| B | 0.485 | 0.495 | 12.32 | 12.57 |
| C | 0.165 | 0.180 | 4.20 | 4.57 |
| E | 0.090 | 0.110 | 2.29 | 2.79 |
| F | 0.013 | 0.021 | 0.33 | 0.53 |
| G | 0.050 BSC | | 1.27 BSC | |
| H | 0.026 | 0.032 | 0.66 | 0.81 |
| J | 0.020 | --- | 0.51 | --- |
| K | 0.025 | --- | 0.64 | --- |
| R | 0.450 | 0.456 | 11.43 | 11.58 |
| U | 0.450 | 0.456 | 11.43 | 11.58 |
| V | 0.042 | 0.048 | 1.07 | 1.21 |
| W | 0.042 | 0.048 | 1.07 | 1.21 |
| X | 0.042 | 0.056 | 1.07 | 1.42 |
| Y | --- | 0.020 | --- | 0.50 |
| Z | 2° | 10° | 2° | 10° |
| G1 | 0.410 | 0.430 | 10.42 | 10.92 |
| K1 | 0.040 | --- | 1.02 | --- |

MC10E151, MC100E151

ECLinPS is a registered trademark of Semiconductor Components Industries, LLC (SCILLC) or its subsidiaries in the United States and/or other countries.

ON Semiconductor and  are trademarks of Semiconductor Components Industries, LLC dba ON Semiconductor or its subsidiaries in the United States and/or other countries. ON Semiconductor owns the rights to a number of patents, trademarks, copyrights, trade secrets, and other intellectual property. A listing of ON Semiconductor's product/patent coverage may be accessed at www.onsemi.com/site/pdf/Patent-Marking.pdf. ON Semiconductor reserves the right to make changes without further notice to any products herein. ON Semiconductor makes no warranty, representation or guarantee regarding the suitability of its products for any particular purpose, nor does ON Semiconductor assume any liability arising out of the application or use of any product or circuit, and specifically disclaims any and all liability, including without limitation special, consequential or incidental damages. Buyer is responsible for its products and applications using ON Semiconductor products, including compliance with all laws, regulations and safety requirements or standards, regardless of any support or applications information provided by ON Semiconductor. "Typical" parameters which may be provided in ON Semiconductor data sheets and/or specifications can and do vary in different applications and actual performance may vary over time. All operating parameters, including "Typicals" must be validated for each customer application by customer's technical experts. ON Semiconductor does not convey any license under its patent rights nor the rights of others. ON Semiconductor products are not designed, intended, or authorized for use as a critical component in life support systems or any FDA Class 3 medical devices or medical devices with a same or similar classification in a foreign jurisdiction or any devices intended for implantation in the human body. Should Buyer purchase or use ON Semiconductor products for any such unintended or unauthorized application, Buyer shall indemnify and hold ON Semiconductor and its officers, employees, subsidiaries, affiliates, and distributors harmless against all claims, costs, damages, and expenses, and reasonable attorney fees arising out of, directly or indirectly, any claim of personal injury or death associated with such unintended or unauthorized use, even if such claim alleges that ON Semiconductor was negligent regarding the design or manufacture of the part. ON Semiconductor is an Equal Opportunity/Affirmative Action Employer. This literature is subject to all applicable copyright laws and is not for resale in any manner.

PUBLICATION ORDERING INFORMATION

LITERATURE FULFILLMENT:

Literature Distribution Center for ON Semiconductor
19521 E. 32nd Pkwy, Aurora, Colorado 80011 USA
Phone: 303-675-2175 or 800-344-3860 Toll Free USA/Canada
Fax: 303-675-2176 or 800-344-3867 Toll Free USA/Canada
Email: orderlit@onsemi.com

N. American Technical Support: 800-282-9855 Toll Free
USA/Canada
Europe, Middle East and Africa Technical Support:
Phone: 421 33 790 2910
Japan Customer Focus Center
Phone: 81-3-5817-1050

ON Semiconductor Website: www.onsemi.com
Order Literature: <http://www.onsemi.com/orderlit>
For additional information, please contact your local
Sales Representative

Looking for pricing, stock, or lifecycle information?

Click below to explore more details on WIN SOURCE:

 [View MC100E151FNG on WIN SOURCE](#)

 [ON Semiconductor](#) Information

Optimize Your Supply Chain with WIN SOURCE Solutions

-  Global Sourcing Solution
-  Obsolete Management
-  Cost Control Management
-  Shortage Management
-  Alternative Solution
-  Excess Inventory Management