



**THE DATASHEET OF
MBC13720**





MBC13720

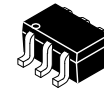

Package Information
Plastic Package
Case 419B
(SOT-363)

Ordering Information

Device	Device Marking or Operating Temperature Range	Package
MBC13720NT1 ¹	20N	SOT-363

¹ Refer to [Table 1](#).

MBC13720

SiGe:C Low Noise Amplifier with Bypass Switch

1 Introduction

The MBC13720 is a high IP₃, low noise amplifier designed for 400 MHz to 2.4 GHz multi-standard wireless applications. The input and output match is external to allow maximum design flexibility. The LNA has two selectable current settings as well as a standby mode. The LNA operates from a 2.5 to 3.0 V supply. The MBC13720 is fabricated using an advanced RF BiCMOS process with the SiGe:C option and is housed in an ultra small SOT-363 surface mount package.

1.1 Features

- Selectable current, 5.0 mA or 11 mA
- Standby mode to turn off device completely
- High Input IP₃:
10 dBm @ 1.9 GHz
13 dBm @ 2.4 GHz
- Low Noise Figure:
1.38 dB @ 1.9 GHz
1.55 dB @ 2.4 GHz

Contents

1 Introduction	1
2 Ordering Information	2
3 Electrical Specifications	3
4 Parameters	5
5 Application Information	9
6 Packaging	15
7 Product Documentation	15

Freescale reserves the right to change the detail specifications as may be required to permit improvements in the design of its products.

© Freescale Semiconductor, Inc., 2005–2011. All rights reserved.

Ordering Information

- Gain @ 9.0 mA, 2.75 V:
14.5 dB @ 1.9 GHz
12 dB @ 2.4 GHz
- Suitable for use from 400 MHz to 2.4 GHz
- Bias stabilized for device and temperature variations
- Ultra small SOT-363 surface mount package
- Available only in tape and reel packaging
- Available only in a lead free version (device number MBC13720NT1) (Refer to [Table 1.](#))

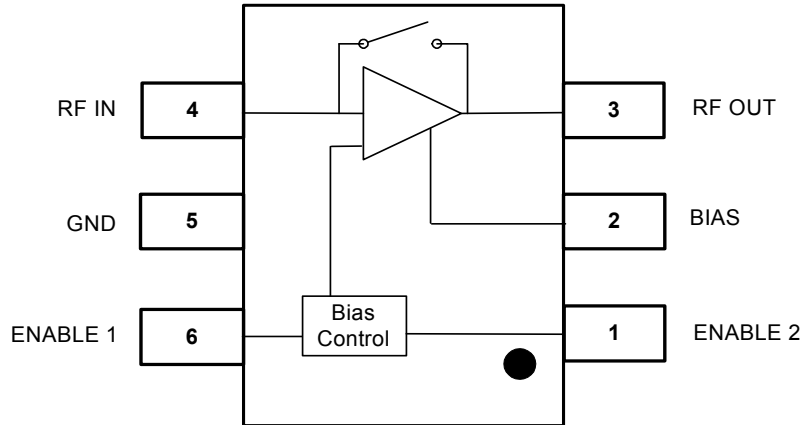

Figure 1. Pin Connections

2 Ordering Information

[Table 1](#) provides additional details on MBC13720 orderable parts.

Table 1. Orderable Parts Details

Device	Operating Temp Range (TA.)	Package	Lead Frame	RoHS Compliant	PB-Free	MSL Level	Solder Temp
MBC13720NT1	-40° to 85° C	Tape and Reel	Pb Free	Yes	Yes	1	260° C

3 Electrical Specifications

Table 2. Maximum Ratings

Ratings	Symbol	Value	Unit
Supply Voltage	V_{CC}	3.3	V
Storage Temperature Range	T_{stg}	-65 to 150	°C
Operating Ambient Temperature Range	T_A	-40 to 85	°C
RF Input Power	Prf	10	dBm
Power Dissipation	Pdis	100	mW

NOTE

1. Maximum Ratings are those values beyond which damage to the device may occur. Functional operation should be restricted to the limits in the Recommended Operating Conditions and Electrical Characteristics tables.
2. ESD (electrostatic discharge) immunity meets Human Body Model (HBM) $\leq 550V$ all pins. Charge Device Model (CDM) $\leq 50V$ all pins.

Table 3. Recommended Operating Conditions

Characteristic	Symbol	Min	Typ	Max	Unit
RF Frequency Range	f_{RF}	400	—	2400	MHz
Supply Voltage	V_{CC}	2.3	2.7	3	V
Logic Voltage					
Input High Voltage, Enable 1 and Enable 2	—	1.5	—	V_{CC}	V
Input Low Voltage, Enable 1 and Enable 2	—	0	—	0.95	V

Table 4. Electrical Characteristics Measured in Frequency Specific Tuned Circuits
 $(V_{CC} = 2.75, T_A = 25^\circ C)$

Characteristic	Symbol	Min	Typ	Max	Unit
Current Consumption					
Low IP3	I_{CC}	—	5.0	—	mA
High IP3			11		mA
Bypass			0		μA
Input/Output Return Loss					
Low IP3	RL	—	10	—	dB
High IP3			10		
Bypass			12		
RF Gain (900 MHz)					
Low IP3	G	—	19	—	dB
High IP3			20		
Bypass			-2.9		

Table 4. Electrical Characteristics Measured in Frequency Specific Tuned Circuits (continued)
 ($V_{CC} = 2.75$, $T_A = 25^\circ \text{C}$)

Characteristic	Symbol	Min	Typ	Max	Unit
RF Gain (1.9 GHz) Low IP3 High IP3 Bypass	G	—	13 14 -2.5	—	dB
RF Gain (2.4 GHz) Low IP3 High IP3 Bypass	G	—	11 12 -2.8	—	dB
Noise Figure 900 MHz 1.9 GHz 2.4 GHz	NF	—	1.2 1.38 1.55	—	dB
Input IP3 (900 MHz) Low IP3 High IP3 Bypass	IIP3	—	-3 2 27	—	dBm
Input IP3 (1.9 GHz) Low IP3 High IP3 Bypass	IIP3	—	4.0 10 29	—	dBm
Input IP3 (2.4 GHz) Low IP3 High IP3 Bypass	IIP3	—	6.0 13 25	—	dBm
Output 1 dB Compression (900 MHz) Low IP3 High IP3 Bypass	P_{1dB}	—	12 11.5 5.0	—	dBm
Output 1 dB Compression (1.9 GHz) Low IP3 High IP3 Bypass	P_{1dB}	—	11 11.5 5.0	—	dBm
Output 1 dB Compression (2.4 GHz) Low IP3 High IP3 Bypass	P_{1dB}	—	14 14 5.0	—	dBm
Reverse Isolation Low IP3 High IP3	$ S_{12} $	—	25 20	—	dB

Table 5. Truth Table

EN1	EN2	State	Current Consumption
Low	Low	Standby	< 20 μ A
Low	High	Bypass	0 μ A
High	Low	High IP3	11 mA (approx.)
High	High	Low IP3	5.0 mA (approx.)

Note: Logic state of “high” equals V_{CC} voltage. Logic state of “low” equals ground potential.

4 Parameters

Table 6. High IP3 Mode 25°C Scattering Parameters

($V_{CC} = 2.7\text{ V}$, EN1 = High, EN2 = Low)

f (MHz)	S ₁₁		S ₂₁		S ₁₂		S ₂₂	
	S ₁₁	∠φ	S ₁₁	∠φ	S ₁₁	∠φ	S ₁₁	∠φ
300	0.615	-85	15.495	57	0.017	51	0.620	-87
400	0.565	-49	13.968	-30	0.022	63	0.631	-84
500	0.520	81	12.575	-70	0.029	-67	0.649	67
600	0.498	85	10.962	74	0.033	-50	0.646	86
700	0.476	-85	9.675	56	0.039	4	0.646	-87
800	0.462	-78	8.657	-35	0.045	56	0.644	-85
900	0.447	33	7.819	-72	0.050	72	0.641	-39
1000	0.438	80	7.106	79	0.055	-69	0.626	84
1100	0.433	85	6.388	70	0.060	-52	0.628	87
1200	0.419	-83	5.961	16	0.063	10	0.622	-86
1300	0.406	-72	5.666	-67	0.071	62	0.610	-81
1400	0.379	64	5.306	-79	0.080	75	0.591	71
1500	0.373	82	4.962	78	0.086	-71	0.588	85
1600	0.382	-84	4.569	61	0.093	-48	0.582	-87
1700	0.396	-79	4.312	-52	0.097	31	0.583	-85
1800	0.399	-40	4.092	-77	0.103	69	0.586	-71
1900	0.393	75	3.942	82	0.110	78	0.585	79
2000	0.398	84	3.715	77	0.118	-72	0.580	86
2100	0.405	-83	3.513	42	0.124	-44	0.575	-86
2200	0.403	-76	3.402	-70	0.130	49	0.565	-83
2300	0.399	50	3.401	-81	0.141	74	0.559	4
2400	0.363	80	3.256	82	0.146	-79	0.548	83
2500	0.363	-84	3.165	74	0.159	-72	0.510	86
2600	0.381	-78	3.050	-42	0.170	-37	0.499	-84
2700	0.393	15	2.909	-79	0.179	65	0.490	-73
2800	0.426	80	2.770	-84	0.183	78	0.513	69
2900	0.431	85	2.574	82	0.185	-79	0.517	84
3000	0.462	-84	2.451	66	0.194	-68	0.527	86

Table 7. High IP3 Mode 85°C Scattering Parameters
 ($V_{CC} = 2.7\text{ V}$, EN1 = High, EN2 = Low)

f (MHz)	S ₁₁		S ₂₁		S ₁₂		S ₂₂	
	S ₁₁	∠φ	S ₁₁	∠φ	S ₁₁	∠φ	S ₁₁	∠φ
300	0.550	-84	16.159	50	0.017	53	0.595	-87
400	0.516	-47	14.168	-39	0.023	67	0.595	-83
500	0.479	80	12.719	-71	0.029	-66	0.632	67
600	0.458	85	11.035	73	0.034	-49	0.622	86
700	0.438	-84	9.665	52	0.040	4	0.626	-87
800	0.429	-77	8.600	-42	0.044	54	0.627	-85
900	0.413	32	7.669	-73	0.050	71	0.623	-31
1000	0.402	79	6.984	78	0.055	-70	0.613	84
1100	0.401	84	6.322	69	0.063	-52	0.612	87
1200	0.384	-82	5.800	5	0.069	18	0.606	-86
1300	0.366	-70	5.467	-69	0.074	62	0.596	-80
1400	0.350	61	5.158	-80	0.081	75	0.578	72
1500	0.338	81	4.803	78	0.087	-71	0.572	85
1600	0.340	-83	4.418	59	0.091	-48	0.560	-87
1700	0.357	-78	4.195	-56	0.096	37	0.562	-84
1800	0.358	-41	3.969	-78	0.103	69	0.562	-68
1900	0.356	74	3.768	82	0.108	78	0.564	80
2000	0.362	83	3.550	77	0.113	-71	0.543	85
2100	0.364	-83	3.412	37	0.122	-43	0.551	-86
2200	0.349	-75	3.256	-72	0.130	50	0.548	-82
2300	0.357	27	3.213	-82	0.134	73	0.549	22
2400	0.322	77	3.140	82	0.139	-79	0.535	83
2500	0.300	-83	3.018	73	0.152	-71	0.500	86
2600	0.286	-76	2.868	-47	0.160	-28	0.482	-84
2700	0.296	-29	2.775	-80	0.170	64	0.488	-73
2800	0.348	76	2.669	-84	0.169	77	0.504	70
2900	0.359	83	2.485	82	0.178	-79	0.509	84
3000	0.386	-83	2.385	67	0.179	-69	0.501	86

Table 8. High IP3 Mode -40°C Scattering Parameters
 (V_{CC} = 2.7 V, EN1 = High, EN2 = Low)

f (MHz)	S ₁₁		S ₂₁		S ₁₂		S ₂₂	
	S ₁₁	∠φ	S ₁₁	∠φ	S ₁₁	∠φ	S ₁₁	∠φ
300	0.614	-85	15.322	55	0.017	49	0.609	-87
400	0.574	-58	13.796	-30	0.021	65	0.611	-83
500	0.534	81	12.602	-70	0.028	-65	0.655	67
600	0.509	85	11.063	74	0.031	-47	0.646	86
700	0.488	-85	9.813	57	0.039	8	0.649	-87
800	0.480	-79	8.774	-32	0.044	57	0.648	-85
900	0.464	24	7.871	-71	0.048	71	0.645	-47
1000	0.454	80	7.219	79	0.054	-69	0.628	84
1100	0.452	85	6.568	71	0.057	-50	0.627	87
1200	0.441	-84	6.082	20	0.064	14	0.627	-86
1300	0.424	-74	5.759	-66	0.071	62	0.623	-81
1400	0.409	61	5.454	-79	0.077	74	0.608	71
1500	0.400	82	5.094	78	0.081	-70	0.604	85
1600	0.407	-85	4.668	62	0.086	-47	0.598	-87
1700	0.428	-81	4.457	-47	0.090	31	0.602	-85
1800	0.426	-53	4.235	-77	0.096	68	0.603	-73
1900	0.427	76	4.036	82	0.103	77	0.607	80
2000	0.430	84	3.808	77	0.108	-72	0.587	86
2100	0.438	-84	3.675	46	0.117	-46	0.602	-87
2200	0.433	-78	3.524	-69	0.121	44	0.594	-83
2300	0.429	37	3.483	-81	0.130	72	0.585	16
2400	0.403	80	3.407	82	0.137	79	0.566	83
2500	0.399	85	3.280	74	0.154	-73	0.541	86
2600	0.409	-80	3.147	-36	0.170	-36	0.521	-84
2700	0.444	-14	3.029	-78	0.176	61	0.523	-74
2800	0.468	81	2.897	-84	0.189	78	0.526	72
2900	0.466	85	2.647	82	0.178	-78	0.544	84
3000	0.507	-85	2.538	67	0.181	-69	0.561	87

Table 9. Low IP3 Mode 25°C Scattering Parameters
 ($V_{CC} = 2.7\text{ V}$, EN1 = High, EN2 = High)

f (MHz)	S ₁₁		S ₂₁		S ₁₂		S ₂₂	
	S ₁₁	∠φ	S ₁₁	∠φ	S ₁₁	∠φ	S ₁₁	∠φ
300	0.737	-87	10.452	66	0.018	54	0.669	-87
400	0.698	-53	9.990	-5	0.024	67	0.682	-85
500	0.655	85	9.594	-68	0.031	-66	0.727	75
600	0.619	87	8.654	78	0.033	-42	0.714	87
700	0.583	-86	7.880	66	0.041	15	0.710	-88
800	0.550	-77	7.200	-9	0.045	58	0.699	-86
900	0.523	69	6.600	-70	0.049	72	0.683	-6
1000	0.497	84	6.094	-80	0.054	-68	0.672	85
1100	0.479	-86	5.622	74	0.059	-48	0.661	87
1200	0.451	-82	5.231	40	0.068	24	0.648	-87
1300	0.426	-57	4.960	-64	0.069	63	0.632	-80
1400	0.404	74	4.757	-79	0.075	75	0.622	76
1500	0.402	83	4.417	80	0.082	-70	0.615	86
1600	0.397	-83	4.105	68	0.084	-44	0.594	-87
1700	0.400	-76	3.925	-42	0.089	38	0.601	-85
1800	0.395	27	3.755	-77	0.098	68	0.592	-65
1900	0.390	79	3.560	-83	0.101	77	0.602	81
2000	0.389	84	3.350	79	0.108	-70	0.581	86
2100	0.384	-82	3.200	53	0.117	-40	0.577	-86
2200	0.382	-69	3.117	-69	0.121	47	0.573	-82
2300	0.374	63	3.036	-81	0.133	73	0.568	33
2400	0.344	81	2.954	83	0.137	-79	0.547	83
2500	0.338	-83	2.811	76	0.153	-72	0.535	86
2600	0.362	-74	2.743	-36	0.164	-30	0.514	-84
2700	0.371	54	2.623	-80	0.170	65	0.499	-73
2800	0.414	81	2.490	-85	0.172	77	0.520	69
2900	0.410	-85	2.265	83	0.169	-78	0.529	84
3000	0.402	-81	2.145	70	0.174	-67	0.540	87

Table 10. Low IP3 Mode 85°C Scattering Parameters
 ($V_{CC} = 2.7\text{ V}$, EN1 = High, EN2 = High)

f (MHz)	S ₁₁		S ₂₁		S ₁₂		S ₂₂	
	S ₁₁	∠φ	S ₁₁	∠φ	S ₁₁	∠φ	S ₁₁	∠φ
300	0.722	-87	10.245	64	0.016	53	0.584	-86
400	0.681	-45	10.107	-8	0.025	66	0.650	-84
500	0.631	84	9.758	-69	0.030	-66	0.718	76
600	0.601	87	8.730	77	0.036	-47	0.709	87
700	0.564	-85	7.901	65	0.040	11	0.708	-88
800	0.534	-76	7.185	-15	0.046	60	0.690	-85
900	0.512	70	6.564	-71	0.051	72	0.680	1
1000	0.484	83	6.062	-80	0.056	-69	0.670	85
1100	0.467	-86	5.559	74	0.061	-45	0.657	87
1200	0.440	-82	5.165	36	0.066	18	0.646	-86
1300	0.415	-57	4.925	-65	0.072	62	0.628	-80
1400	0.394	74	4.700	-79	0.077	75	0.616	76
1500	0.391	83	4.348	80	0.084	-70	0.606	86
1600	0.389	-83	4.051	67	0.091	-46	0.586	-87
1700	0.388	-76	3.857	-45	0.097	37	0.594	-84
1800	0.381	16	3.689	-77	0.100	69	0.580	-62
1900	0.384	78	3.489	-83	0.107	77	0.589	81
2000	0.380	84	3.291	79	0.114	-71	0.571	86
2100	0.377	-82	3.139	52	0.122	-46	0.574	-86
2200	0.371	-72	3.049	-70	0.131	50	0.567	-82
2300	0.369	50	2.974	-82	0.139	74	0.562	41
2400	0.343	80	2.941	83	0.143	-79	0.540	83
2500	0.315	-83	2.771	76	0.157	-72	0.525	86
2600	0.323	-76	2.711	-30	0.167	-29	0.511	-84
2700	0.340	8	2.636	-79	0.174	63	0.519	-73
2800	0.382	77	2.521	-84	0.179	77	0.533	72
2900	0.410	-85	2.265	83	0.169	-78	0.529	84
3000	0.402	-81	2.145	70	0.174	-67	0.540	87

Table 11. Low IP3 Mode -40°C Scattering Parameters
 ($V_{CC} = 2.7\text{ V}$, EN1 = High, EN2 = High)

f (MHz)	S ₁₁		S ₂₁		S ₁₂		S ₂₂	
	S ₁₁	∠φ	S ₁₁	∠φ	S ₁₁	∠φ	S ₁₁	∠φ
300	0.756	-87	9.834	67	0.019	57	0.676	-88
400	0.727	-64	9.449	5	0.025	67	0.686	-85
500	0.678	85	9.174	-67	0.031	-66	0.745	76
600	0.645	87	8.335	78	0.035	-46	0.736	87
700	0.607	-86	7.647	68	0.040	20	0.731	-88
800	0.575	-79	7.025	0	0.046	60	0.715	-86
900	0.549	70	6.485	-69	0.050	72	0.703	-15
1000	0.525	84	6.047	-79	0.055	-68	0.693	85
1100	0.505	-86	5.547	75	0.056	-43	0.681	88
1200	0.475	-83	5.196	45	0.064	29	0.672	-87
1300	0.451	-63	4.976	-62	0.066	64	0.653	-81
1400	0.431	75	4.763	-78	0.071	75	0.642	77
1500	0.426	84	4.415	80	0.075	-69	0.640	86
1600	0.422	-84	4.138	69	0.083	-42	0.623	-87
1700	0.422	-77	3.944	-36	0.085	39	0.625	-85
1800	0.419	22	3.787	-76	0.091	68	0.610	-67
1900	0.417	79	3.597	-83	0.094	77	0.626	82
2000	0.417	85	3.395	79	0.100	-71	0.602	86
2100	0.411	-83	3.236	56	0.113	-46	0.605	-87
2200	0.406	-70	3.141	-68	0.122	46	0.584	-82
2300	0.390	65	3.048	-81	0.132	73	0.573	35
2400	0.351	81	2.976	83	0.136	-79	0.557	83
2500	0.339	-83	2.836	77	0.145	-72	0.547	86
2600	0.371	-76	2.806	-23	0.155	-31	0.533	-85
2700	0.405	47	2.698	-79	0.157	61	0.539	-75
2800	0.439	81	2.556	-84	0.163	77	0.552	72
2900	0.464	86	2.336	83	0.167	-79	0.567	85
3000	0.469	-83	2.213	70	0.178	-69	0.568	-87

Table 12. Bypass Mode 25°C Scattering Parameters
 ($V_{CC} = 2.7\text{ V}$, EN1 = Low, EN2 = High)

f (MHz)	S ₁₁		S ₂₁		S ₁₂		S ₂₂	
	S ₁₁	∠φ	S ₁₁	∠φ	S ₁₁	∠φ	S ₁₁	∠φ
300	0.866	-88	0.293	76	0.295	76	0.706	-87
400	0.811	79	0.386	85	0.384	85	0.702	-81
500	0.753	87	0.468	-82	0.470	-82	0.736	85
600	0.717	-88	0.514	-2	0.506	6	0.710	88
700	0.671	-85	0.549	83	0.546	83	0.687	-87
800	0.629	29	0.575	87	0.575	87	0.653	-75
900	0.593	84	0.600	-85	0.604	-85	0.618	82
1000	0.556	87	0.615	-64	0.618	-64	0.585	86
1100	0.527	-84	0.624	83	0.626	83	0.555	-86
1200	0.492	-57	0.636	87	0.632	87	0.528	-79
1300	0.456	78	0.647	-87	0.641	-87	0.493	63
1400	0.435	85	0.655	-81	0.649	-81	0.474	83
1500	0.439	-83	0.648	76	0.652	77	0.470	-86
1600	0.440	-70	0.637	86	0.634	86	0.456	-81
1700	0.428	70	0.631	-87	0.628	-87	0.451	-40
1800	0.412	83	0.642	-85	0.626	-85	0.417	78
1900	0.395	-84	0.649	-54	0.641	-59	0.397	84
2000	0.396	-78	0.636	83	0.644	84	0.379	-82
2100	0.384	30	0.626	87	0.633	87	0.344	-68
2200	0.362	79	0.619	-86	0.623	-86	0.322	65
2300	0.346	84	0.622	-81	0.620	-81	0.294	80
2400	0.335	-78	0.615	72	0.610	72	0.274	-81
2500	0.368	-20	0.576	85	0.592	85	0.271	-69
2600	0.398	78	0.546	-87	0.554	-87	0.262	51
2700	0.415	84	0.535	-84	0.530	-84	0.231	76
2800	0.421	-84	0.532	-66	0.510	-66	0.199	-81
2900	0.415	-75	0.533	78	0.532	77	0.173	-73
3000	0.413	60	0.510	85	0.523	85	0.141	20

Table 13. Standby Mode 25°C Scattering Parameters
 ($V_{CC} = 2.7\text{ V}$, EN1 = Low, EN2 = Low)

f (MHz)	S_{11}		S_{21}		S_{12}		S_{22}	
	$ S_{11} $	$\angle \phi$	$ S_{11} $	$\angle \phi$	$ S_{11} $	$\angle \phi$	$ S_{11} $	$\angle \phi$
300	0.938	-89	0.017	50	0.020	49	0.765	-88
400	0.935	-88	0.026	67	0.027	66	0.795	-87
500	0.927	88	0.035	-68	0.034	-69	0.883	68
600	0.922	89	0.042	-53	0.042	-53	0.893	89
700	0.917	-89	0.049	5	0.049	7	0.909	-89
800	0.918	-89	0.054	59	0.055	58	0.909	-89
900	0.911	79	0.064	73	0.063	73	0.907	-82
1000	0.899	89	0.071	-69	0.068	-69	0.894	88
1100	0.891	89	0.075	-48	0.077	-47	0.887	89
1200	0.875	-89	0.080	36	0.081	35	0.884	-89
1300	0.869	-86	0.091	69	0.088	67	0.869	-87
1400	0.852	87	0.099	-77	0.095	-77	0.868	85
1500	0.843	89	0.098	-68	0.102	-69	0.859	89
1600	0.839	-89	0.099	-27	0.103	-25	0.836	-89
1700	0.830	-87	0.106	55	0.107	55	0.838	-88
1800	0.825	80	0.115	73	0.114	73	0.810	-75
1900	0.812	88	0.118	-77	0.120	-77	0.819	87
2000	0.803	-89	0.116	-67	0.121	-67	0.791	88
2100	0.783	-87	0.122	-20	0.125	-24	0.775	-88
2200	0.776	-76	0.131	59	0.124	59	0.769	-86
2300	0.759	86	0.134	76	0.131	75	0.752	76
2400	0.717	88	0.142	-78	0.140	-78	0.733	87
2500	0.710	-87	0.150	-69	0.152	-70	0.710	-88
2600	0.719	-81	0.165	-7	0.168	-13	0.665	-85
2700	0.722	83	0.180	70	0.174	70	0.643	-69
2800	0.713	87	0.182	79	0.177	79	0.607	81
2900	0.707	-88	0.175	-77	0.167	-77	0.624	86
3000	0.667	-84	0.166	-63	0.171	-66	0.598	-87

Table 14. Low IP3 Noise Parameters
($V_{CC} = 2.7\text{ V}$, EN1 = High, EN2 = High)

f (MHz)	Fmin (dB)	Mag	Ang	Rn	Ga (dB)
400	0.57	0.26	15.5	0.19	25.3
410	0.57	0.26	15.7	0.19	24.93
420	0.58	0.26	16	0.19	24.8
430	0.58	0.26	16.2	0.19	24.68
440	0.59	0.26	16.5	0.19	24.56
450	0.59	0.26	16.7	0.19	24.44
460	0.59	0.26	16.9	0.19	24.32
470	0.6	0.26	17.2	0.19	24.2
480	0.6	0.26	17.4	0.19	24.09
490	0.6	0.26	17.7	0.19	23.97
500	0.61	0.26	17.9	0.19	23.85
550	0.63	0.26	19.1	0.19	23.01
600	0.64	0.26	20.3	0.19	22.59
650	0.66	0.25	21.5	0.19	22.16
700	0.67	0.25	22.7	0.19	21.74
750	0.69	0.25	23.9	0.19	21.32
800	0.7	0.25	25.1	0.19	20.89
850	0.72	0.24	26.4	0.19	20.47
900	0.73	0.24	27.6	0.19	20.05
1000	0.76	0.24	30	0.19	19.2

Table 15. High IP3 Noise Parameters
($V_{CC} = 2.7\text{ V}$, EN1 = High, EN2 = Low)

f (MHz)	Fmin (dB)	Mag	Ang	Rn	Ga (dB)
400	0.65	0.2	5.5	0.22	26.21
410	0.65	0.2	6.1	0.22	26.06
420	0.65	0.2	6.7	0.22	25.91
430	0.66	0.19	7.3	0.21	25.76
440	0.66	0.19	7.9	0.21	25.61
450	0.66	0.19	8.5	0.21	25.46
460	0.66	0.19	9.1	0.21	25.31
470	0.66	0.19	9.7	0.21	25.16

Table 15. High IP3 Noise Parameters (continued)

 ($V_{CC} = 2.7\text{ V}$, EN1 = High, EN2 = Low)

f (MHz)	Fmin (dB)	Mag	Ang	Rn	Ga (dB)
480	0.67	0.18	10.3	0.2	25.01
490	0.67	0.18	10.9	0.2	24.87
500	0.67	0.18	11.5	0.2	24.54
550	0.68	0.17	14.5	0.19	24.06
600	0.69	0.16	17.5	0.19	23.59
650	0.7	0.15	20.5	0.18	23.12
700	0.71	0.14	23.5	0.18	22.65
750	0.72	0.13	26.5	0.17	22.17
800	0.73	0.12	29.4	0.17	21.7
850	0.74	0.11	32.4	0.16	21.23
900	0.75	0.1	35.4	0.16	20.76
1000	0.77	0.09	41.4	0.15	19.81

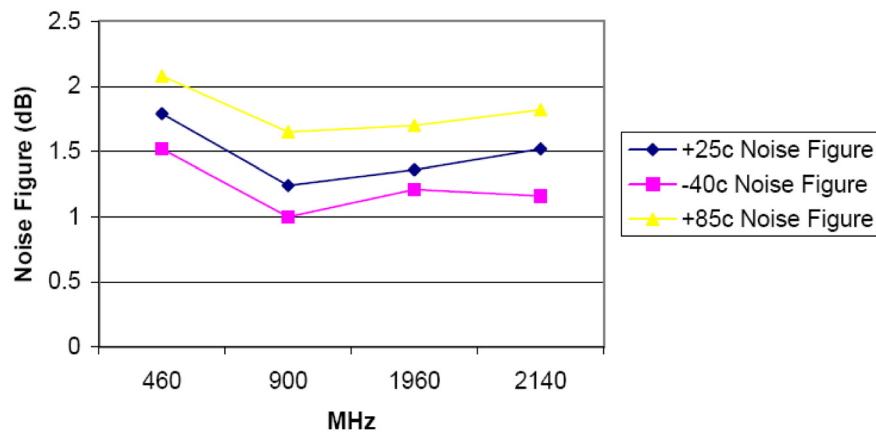
Noise Figure vs Temp (Low IP3 mode)
 (measured in frequency specific circuits)

Figure 2. Noise Figure vs Temperature (Low IP3 Mode)

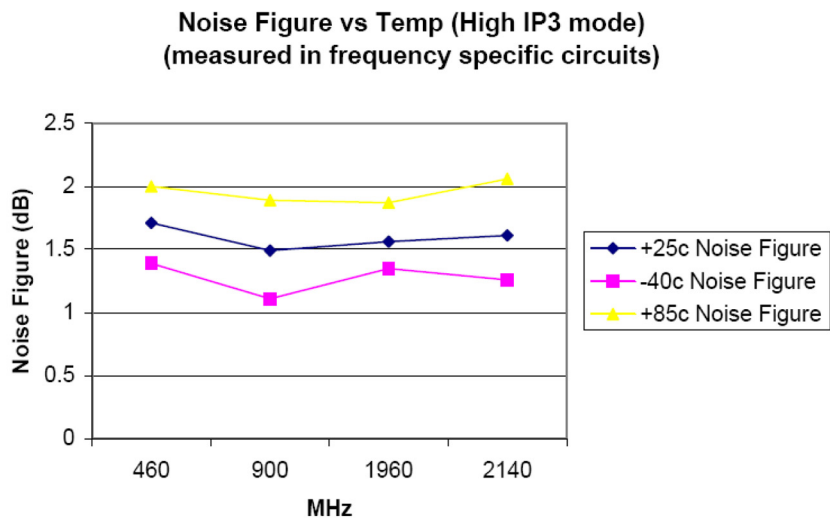

Figure 3. Noise Figure vs Temperature (High IP3 Mode)

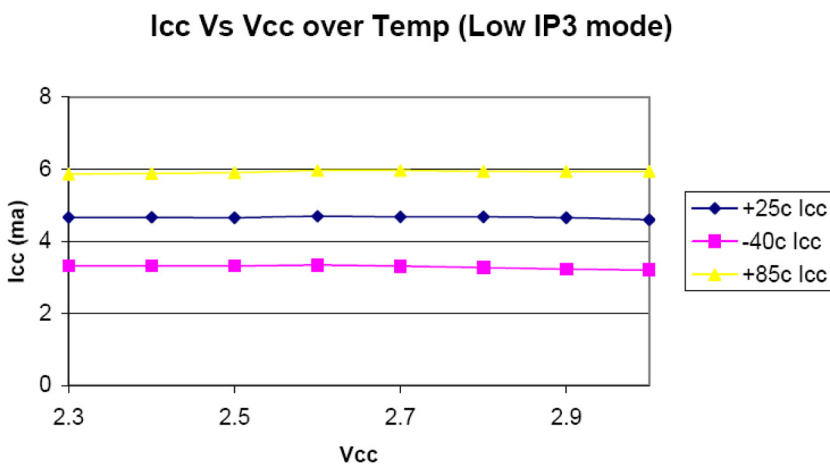

Figure 4. Icc vs Vcc Over Temperature (Low IP3 Mode)

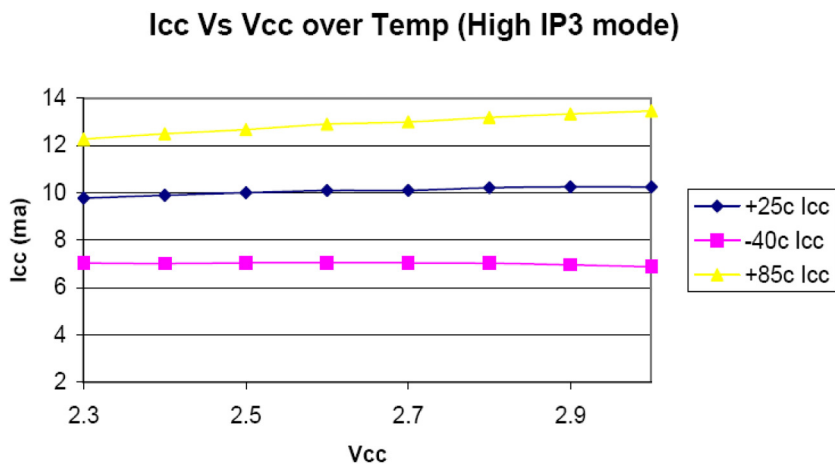

Figure 5. Icc vs Vcc Over Temperature (High IP3 Mode)

5 Application Information

The MBC13720 SiGe:C LNA is designed for applications in the 400 MHz to 2.4 GHz range. It has four different modes: Low IP3, High IP3, Bypass, and Standby. The IC is programmable through the Enable 1 and Enable 2 pins. In Low IP3 mode, current consumption is optimized. Current consumption is higher in High IP3 mode to boost the intercept point performance. The gain difference between Low IP3 and High IP3 modes is typically 1.0 dB; and typically the Low IP3 mode has a slightly better noise figure performance.

The internal bypass switch is designed for broadband applications. One of the advantages of the MBC13720 is the simplification of the matching network in both bypass and amplifier modes. The bypass switch is designed so that changes of input and output return losses between bypass mode and amplifier mode are minimized. As a result, the mismatch at the LNA input and output is minimized and the matching network design is simplified.

In the design of the external matching network, conjugate matching does not necessarily provide the best noise figure performance. Balancing between noise figure, gain, and intercept point is the major design consideration.

[Figure 6](#) shows the typical application circuit at 1.9 and 2.4 GHz. The noise figure, input intercept point, gain, and return losses are optimized. L1 and C2 act as a low frequency trap to improve the input intercept point.

In [Figure 7](#), the typical application circuit for 900 MHz is shown. The input low frequency trap again is used to maximize the input intercept point. It has moderate IP3 performance and high gain. [Figure 8](#) shows the 900 MHz application circuit with feedback network for higher IP3. Capacitive feedback is used to increase the third order input intercept point while decreasing gain and provides unconditional stability.

The corresponding PCBs are shown in [Figure 9](#) through [Figure 11](#). [Table 16](#) lists the bill of materials for the 1900 MHz, 900 MHz, and High IP3 900 MHz application circuits. Typical characteristics of the application boards are shown in [Table 17](#).

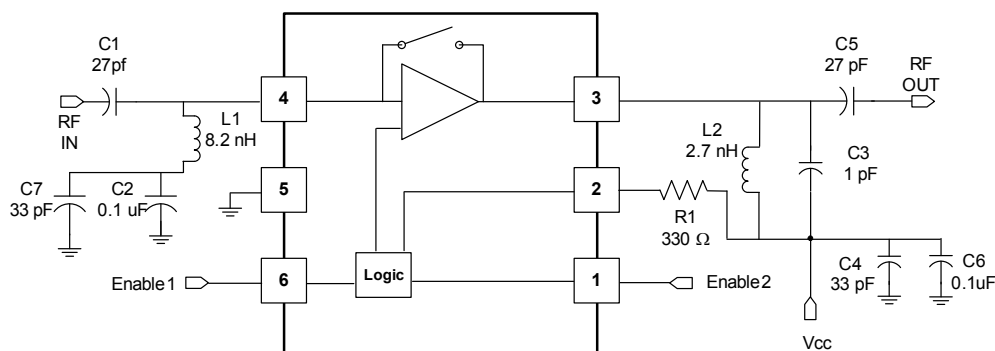

Figure 6. Typical 1.9 and 2.4 GHz LNA Application Schematic

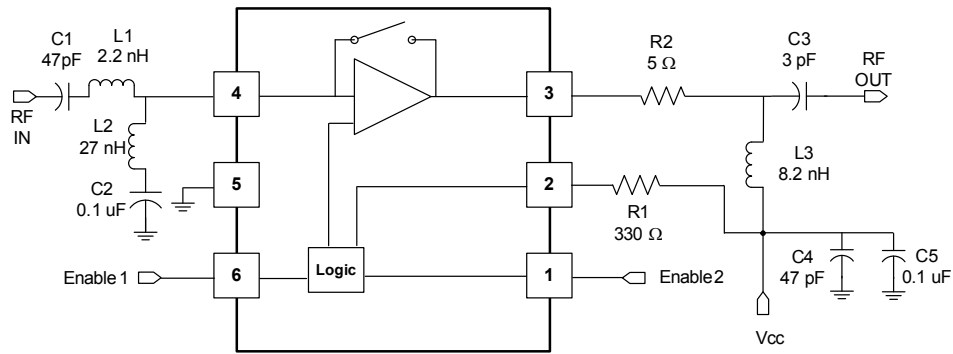

Figure 7. Typical 900 MHz LNA Application Schematic

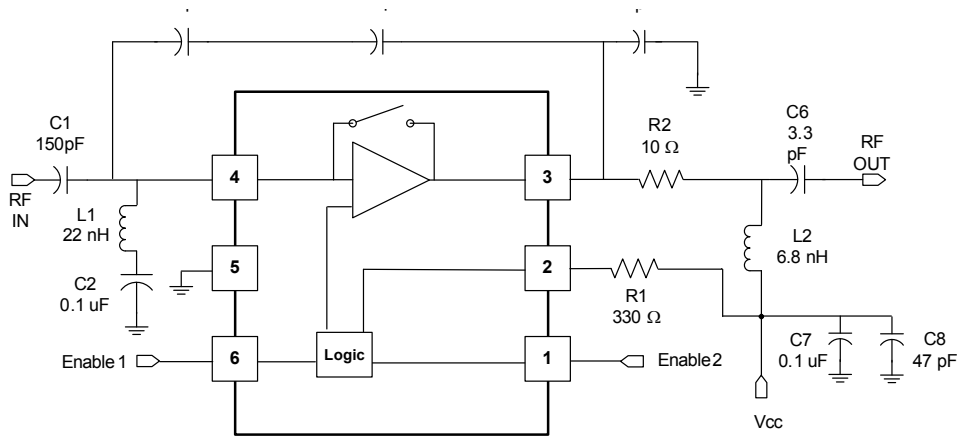

Figure 8. High IP3 900 MHz LNA Application Schematic

Table 16. Bill of Materials for the Application Circuits¹

Component	Value	Case	Manufacturer	Comments
1900 MHz Figure 6 Application Circuit				
C1	27 pF	0402	Murata	DC Block, Input match
C2	0.1 uF	0603	Murata	Low freq bypass
C3	1.0 pF	0402	Murata	Output match
C4	33 pF	0402	Murata	Low freq bypass
C5	27 pF	0402	Murata	DC Block, Output match
C6	0.1 uF	0603	Murata	Low freq bypass
C7	33 pF	0402	Murata	RF bypass
L1	8.2 nH	0402	Toko	Low freq bypass
L2	2.7 nH	0402	Toko	DC feed, Output match
R1	330 ohm	0402	KOA	Bias

Table 16. Bill of Materials for the Application Circuits¹ (continued)

Component	Value	Case	Manufacturer	Comments
Q1	MBC13720	SOT363	Freescale	Freescale SiGe LNA
900 MHz Figure 7 Application Circuit				
C1	47 pF	0402	Murata	DC Block, Input match
C2	0.1 uF	0603	Murata	Low freq bypass
C3	3.0 pF	0402	Murata	DC block, Output match
C4	47 pF	0402	Murata	900 MHz short
C5	0.1 uF	0603	Murata	Low freq bypass
L1	2.2 nH	0402	Toko	Input match
L2	27 nH	0402	Toko	Input match
L3	8.2 nH	0402	Toko	Output match, bias decouple
R1	330 ohm	0402	KOA	Bias
R2	5 ohm	0402	KOA	Stability
Q1	MBC13720	SOT363	Freescale	Freescale SiGe LNA
High IP3 900 MHz Figure 8 Application Circuit				
C1	150 pF	402	Murata	DC Block, Input match
C2	0.1 uF	0603	Murata	Low freq bypass
C3	0.5 pF	402	Murata	IP3 improvement
C4	0.5 pF	402	Murata	IP3 improvement
C5	1.0 pF	402	Murata	RF bypass
C6	3.3 pF	402	Murata	Output match
C7	0.1 uF	0603	Murata	Low freq bypass
C8	47 pF	0402	Murata	RF Bypass
L1	22 nH	402	Toko	Input match
L2	6.8 nH	402	Toko	DC feed, output match
R1	330 ohm	402	KOA	Bias
R2	10 ohm	402	KOA	Stability
Q1	MBC13720	SOT363	Freescale	Freescale SiGe LNA

¹ All components are RoHS compliant.

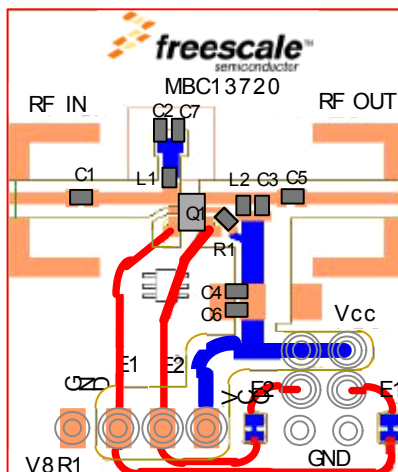

Figure 9. 1.9/2.4 GHz Assembly Diagram

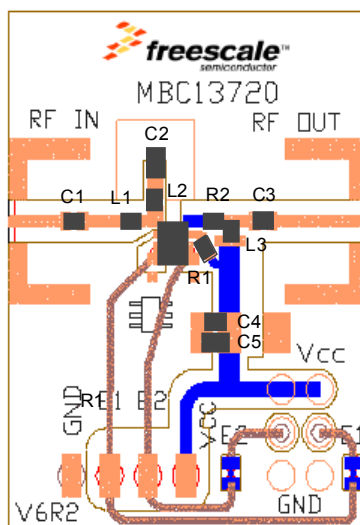

Figure 10. 900 MHz Assembly Diagram

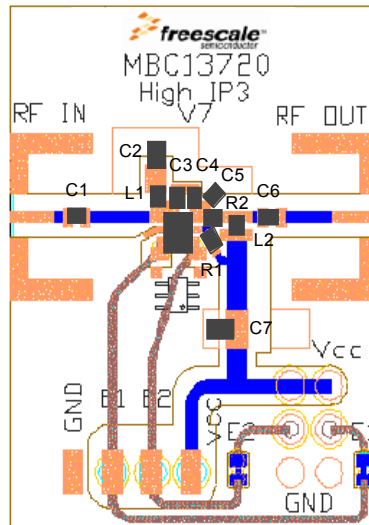

Figure 11. 900 MHz Capacitive Feedback Assembly Diagram

Table 17. Typical Electrical Characteristics of the Application Circuits

Mode	Symbol	High IP3	Low IP3	Bypass	Standby	Unit
900 MHz TYPICAL (See Figure 7)						
Gain	G	20	19	-2.9	-22	dB
Noise Figure	NF	1.3	1.2	2.9	—	dB
Input Intermodulation Intercept Point	IIP3	2.0	-3.0	29	—	dBm
Output Intermodulation Intercept Point	OIP3	23	17	26	—	dBm
Output 1dB Compression Point	P_{1dB}	11.5	10.5	5.0	—	dBm
Input Return Loss	$ S_{11} ^2$	11	10	12	—	dB
Output Return Loss	$ S_{22} ^2$	11	10	15	—	dB
Reverse Isolation	$ S_{12} ^2$	25	24	2.9	22	dB
900 MHz HIGH IP3 (See Figure 8)						
Gain	G	16	15	-4.0	-14.5	dB
Noise Figure	NF	1.4	1.3	4.0	—	dB
Input Intermodulation Intercept Point	IIP3	10	2.0	27	—	dBm
Output Intermodulation Intercept Point	OIP3	26	18.5	23	—	dBm
Output 1 dB Compression Point	P_{1dB}	11.5	12	5.0	—	dBm
Input Return Loss	$ S_{11} ^2$	12	11	8.0	—	dB
Output Return Loss	$ S_{22} ^2$	12	12	14	—	dB
Reverse Isolation	$ S_{12} ^2$	22	20	4.0	14.5	dB

Table 17. Typical Electrical Characteristics of the Application Circuits (continued)

Mode	Symbol	High IP3	Low IP3	Bypass	Standby	Unit
1.9 GHz (See Figure 6)						
Gain	G	14	13	-2.5	-16	dB
Noise Figure	NF	1.5	1.4	2.5	—	dB
Input Intermodulation Intercept Point	IIP3	10	4.0	29	—	dBm
Output Intermodulation Intercept Point	OIP3	24.4	17	26.5	—	dBm
Output 1dB Compression Point	P _{1dB}	11.5	11	5.0	—	dBm
Input Return Loss	IS ₁₁ ²	10	8.0	20	—	dB
Output Return Loss	IS ₂₂ ²	8.0	7.0	30	—	dB
Reverse Isolation	IS ₁₂ ²	19	19	2.5	16	dB
2.4 GHz (See Figure 6)						
Gain	G	12	11	-2.8	-15	dB
Noise Figure	NF	1.7	1.55	2.8	—	dB
Input Intermodulation Intercept Point	IIP3	13	6.0	25	—	dBm
Output Intermodulation Intercept Point	OIP3	25	17.5	22	—	dBm
Output 1dB Compression Point	P _{1dB}	14	14	5.0	—	dBm
Input Return Loss	IS ₁₁ ²	12	10	12	—	dB
Output Return Loss	IS ₂₂ ²	8.0	7.0	14	—	dB
Reverse Isolation	IS ₁₂ ²	17	17	2.8	15	dB

6 Packaging

NOTES

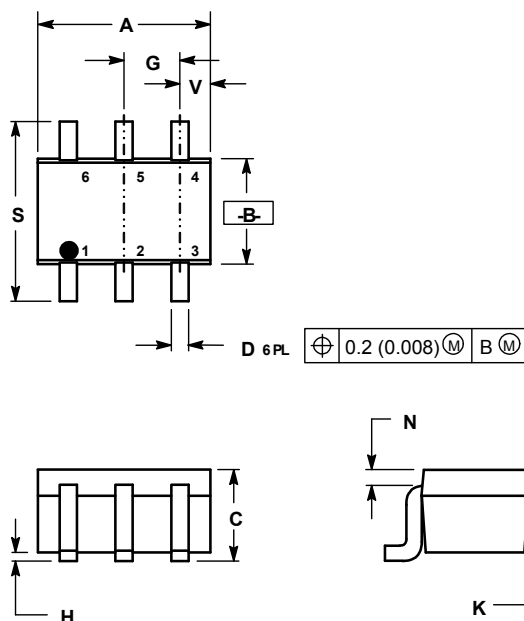

NOTES:

1. DIMENSIONING AND TOLERANCING PER ANSI Y14.5M, 1982.
2. CONTROLLING DIMENSION: INCH.

DIM	INCHES		MILLIMETERS	
	MIN	MAX	MIN	MAX
A	0.071	0.087	1.80	2.20
B	0.045	0.053	1.15	1.35
C	0.031	0.043	0.80	1.10
D	0.004	0.012	0.10	0.30
G	0.026 BSC		0.65 BSC	
H	---	0.004	---	0.10
J	0.004	0.010	0.10	0.25
K	0.004	0.012	0.10	0.30
N	0.008 REF		0.20 REF	
S	0.079	0.087	2.00	2.20
V	0.012	0.016	0.30	0.40

Figure 12. Outline Dimensions for SOT-363 (Case Outline 419B-01, Issue G)

7 Product Documentation

This data sheet is labeled as a particular type: Product Preview, Advance Information, or Technical Data. Definitions of these types are available at: <http://www.freescale.com> on the documentation page.

Table 18 summarizes revisions to this document since the previous release (Rev. 3.5).

Table 18. Revision History

Location	Revision
Section 3, "Electrical Specifications"	Added Note about Maximum ratings and ESD specifications.
Figure 6 through Figure 8	Updated figure content

How to Reach Us:

Home Page:
www.freescale.com

E-mail:
support@freescale.com

USA/Europe or Locations Not Listed:
Freescale Semiconductor
Technical Information Center, CH370
1300 N. Alma School Road
Chandler, Arizona 85224
+1-800-521-6274 or +1-480-768-2130
support@freescale.com

Europe, Middle East, and Africa:
Freescale Halbleiter Deutschland GmbH
Technical Information Center
Schatzbogen 7
81829 Muenchen, Germany
+44 1296 380 456 (English)
+46 8 52200080 (English)
+49 89 92103 559 (German)
+33 1 69 35 48 48 (French)
support@freescale.com

Japan:
Freescale Semiconductor Japan Ltd.
Headquarters
ARCO Tower 15F
1-8-1, Shimo-Meguro, Meguro-ku,
Tokyo 153-0064, Japan
0120 191014 or +81 3 5437 9125
support.japan@freescale.com

Asia/Pacific:
Freescale Semiconductor Hong Kong Ltd.
Technical Information Center
2 Dai King Street
Tai Po Industrial Estate
Tai Po, N.T., Hong Kong
+800 2666 8080
support.asia@freescale.com

For Literature Requests Only:
Freescale Semiconductor Literature Distribution Center
P.O. Box 5405
Denver, Colorado 80217
1-800-521-6274 or 303-675-2140
Fax: 303-675-2150
LDCForFreescaleSemiconductor@hibbertgroup.com

Information in this document is provided solely to enable system and software implementers to use Freescale Semiconductor products. There are no express or implied copyright licenses granted hereunder to design or fabricate any integrated circuits or integrated circuits based on the information in this document.

Freescale Semiconductor reserves the right to make changes without further notice to any products herein. Freescale Semiconductor makes no warranty, representation or guarantee regarding the suitability of its products for any particular purpose, nor does Freescale Semiconductor assume any liability arising out of the application or use of any product or circuit, and specifically disclaims any and all liability, including without limitation consequential or incidental damages. "Typical" parameters that may be provided in Freescale Semiconductor data sheets and/or specifications can and do vary in different applications and actual performance may vary over time. All operating parameters, including "Typicals", must be validated for each customer application by customer's technical experts. Freescale Semiconductor does not convey any license under its patent rights nor the rights of others. Freescale Semiconductor products are not designed, intended, or authorized for use as components in systems intended for surgical implant into the body, or other applications intended to support or sustain life, or for any other application in which the failure of the Freescale Semiconductor product could create a situation where personal injury or death may occur. Should Buyer purchase or use Freescale Semiconductor products for any such unintended or unauthorized application, Buyer shall indemnify and hold Freescale Semiconductor and its officers, employees, subsidiaries, affiliates, and distributors harmless against all claims, costs, damages, and expenses, and reasonable attorney fees arising out of, directly or indirectly, any claim of personal injury or death associated with such unintended or unauthorized use, even if such claim alleges that Freescale Semiconductor was negligent regarding the design or manufacture of the part.

Freescale™ and the Freescale logo are trademarks of Freescale Semiconductor, Inc. All other product or service names are the property of their respective owners.



© Freescale Semiconductor, Inc. 2005–2011. All rights reserved.

RoHS-compliant and/or Pb-free versions of Freescale products have the functionality and electrical characteristics of their non-RoHS-compliant and/or non-Pb-free counterparts. For further information, see <http://www.freescale.com> or contact your Freescale sales representative.

For information on Freescale's Environmental Products program, go to <http://www.freescale.com/epp>.

Looking for pricing, stock, or lifecycle information?

Click below to explore more details on WIN SOURCE:

-  [View MBC13720 on WIN SOURCE](#)
-  [Freescale Semiconductor - NXP Information](#)

Optimize Your Supply Chain with WIN SOURCE Solutions

-  Global Sourcing Solution
-  Obsolete Management
-  Cost Control Management
-  Shortage Management
-  Alternative Solution
-  Excess Inventory Management