



**THE DATASHEET OF  
MB3793-37APNF-G-JN-ER6E1**





# Power Voltage Monitoring IC with Watchdog Timer Datasheet

The MB3793 is an integrated circuit to monitor power voltage; it incorporates a watchdog timer. A reset signal is output when the power is cut or falls abruptly. When the power recovers normally after resetting, a power-on reset signal is output to microprocessor units (MPUs). An internal watchdog timer with two inputs for system operation diagnosis can provide a fall-safe function for various application systems. The model number is MB3793-37A corresponding to the detected voltage. The model number and package code are as shown below.

Model No.	Marking code	Detection voltage
MB3793-37A	3793AF	3.7 V

## Features

- Precise detection of power voltage fall:  $\pm 2.5\%$
- Detection voltage with hysteresis
- Low power dispersion:  $I_{CC} = 30 \mu A$  (reference)
- Internal dual-input watchdog timer
- Watchdog-timer halt function (by inhibition pin)
- Independently-set watchdog and reset times
- Two types of packages (SOP-8pin : 2 types)

## Application

- Arcade Amusement etc

**Contents**

<b>Pin Assignment</b> .....	<b>3</b>	<b>Operation Sequence</b> .....	<b>13</b>
<b>Pin Description</b> .....	<b>3</b>	<b>Typical Characteristics</b> .....	<b>16</b>
<b>Block Diagram</b> .....	<b>4</b>	<b>Application Example</b> .....	<b>20</b>
<b>Block Description</b> .....	<b>5</b>	<b>Supply voltage monitor and watchdog timer</b>	
<b>Absolute Maximum Ratings</b> .....	<b>6</b>	<b>(1-clock monitor)</b> .....	<b>20</b>
<b>Recommended Operating Conditions</b> .....	<b>6</b>	<b>Supply voltage monitor and watchdog timer stop</b> .....	<b>21</b>
<b>Electrical Characteristics</b> .....	<b>7</b>	<b>Typical Application</b> .....	<b>22</b>
DC Characteristics .....	7	<b>Notes On Use</b> .....	<b>23</b>
AC Characteristics .....	8	<b>Ordering Information</b> .....	<b>23</b>
<b>Diagram</b> .....	<b>9</b>	<b>RoHS Compliance Information of</b>	
Basic operation (Positive clock pulse) .....	9	<b>Lead (Pb) Free version</b> .....	<b>23</b>
Basic operation (Negative clock pulse) .....	10	<b>Marking Format (Lead Free version)</b> .....	<b>24</b>
Single-clock input monitoring		<b>Labeling Sample (Lead free version)</b> .....	<b>25</b>
(Positive clock pulse) .....	11	<b>MB3793-37APF-□□□E1, MB3793-37APNF-□□□E1</b>	
Inhibition operation (Positive clock pulse) .....	12	<b>Recommended Conditions Of Moisture</b>	
Clock pulse input supplementation		<b>Sensitivity Level</b> .....	<b>26</b>
(Positive clock pulse) .....	13	<b>Package Dimensions</b> .....	<b>28</b>
		<b>Major Changes</b> .....	<b>30</b>

## 1. Pin Assignment

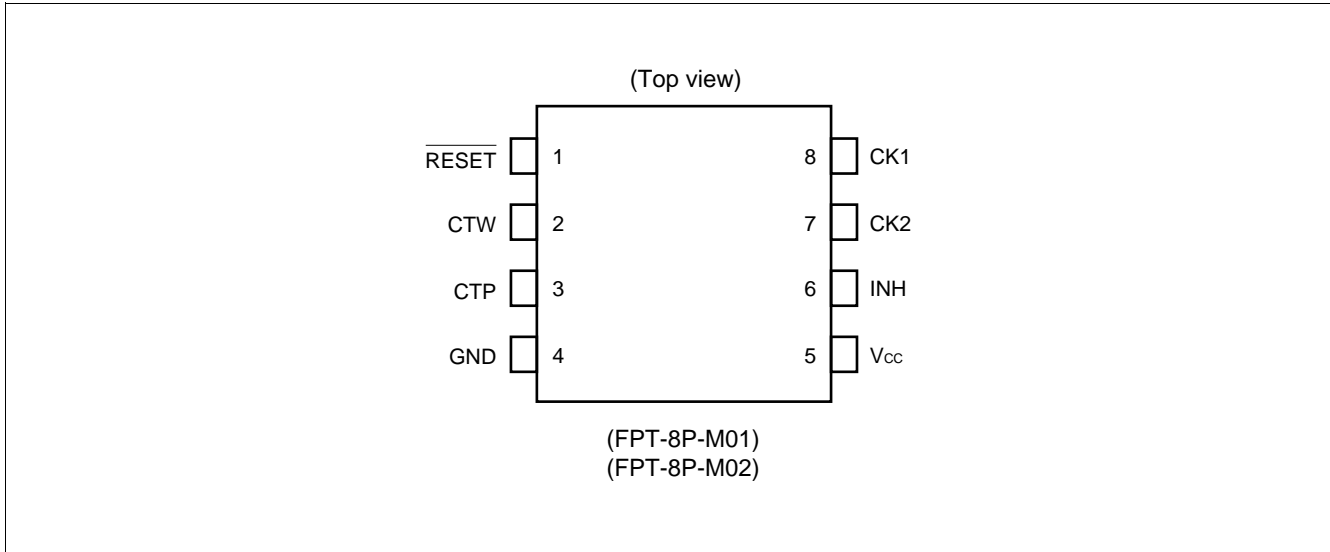

## 2. Pin Description

Pin no.	Symbol	Descriptions	Pin no.	Symbol	Descriptions
1	$\overline{\text{RESET}}$	Outputs reset pin	5	$V_{CC}$	Power supply pin
2	CTW	Watchdog timer monitor time setting pin	6	INH	Inhibit pin
3	CTP	Power-on reset hold time setting pin	7	CK2	Inputs clock 2 pin
4	GND	Ground pin	8	CK1	Inputs clock 1 pin

### 3. Block Diagram

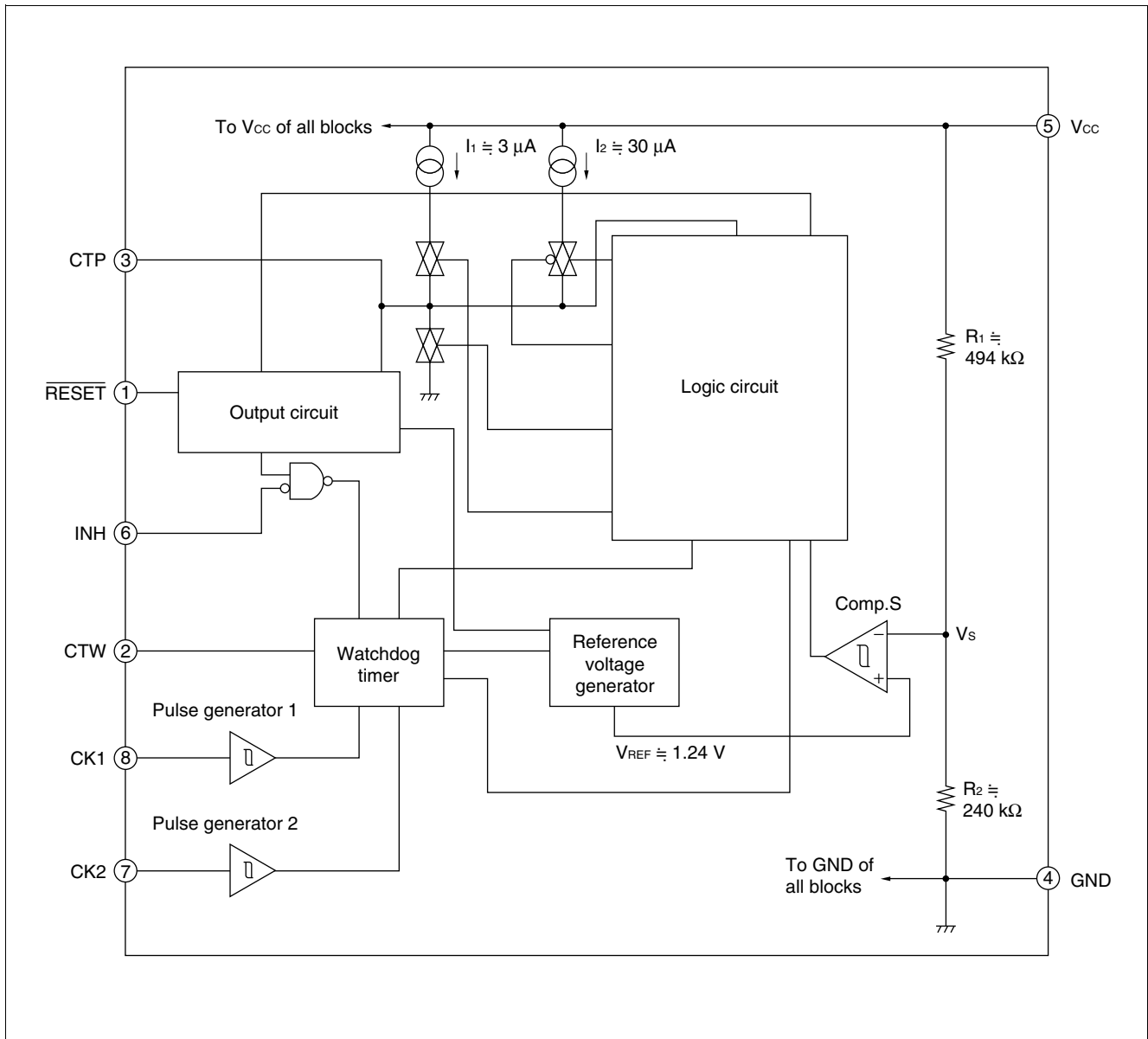

## 4. Block Description

### 1. Comp. S

Comp. S is a comparator with hysteresis to compare the reference voltage with a voltage ( $V_S$ ) that is the result of dividing the power voltage ( $V_{CC}$ ) by resistors 1 and 2. When  $V_S$  falls below 1.24 V, a reset signal is output.

This function enables the MB3793 to detect an abnormality within 1  $\mu$ s when the power is cut or falls abruptly.

### 2. Output circuit

The output circuit contains a  $\overline{\text{RESET}}$  output control comparator that compares the voltage at the CTP pin to the threshold voltage to release the  $\overline{\text{RESET}}$  output if the CTP pin voltage exceeds the threshold value.

Since the reset ( $\overline{\text{RESET}}$ ) output buffer has CMOS organization, no pull-up resistor is needed.

### 3. Pulse generator

The pulse generator generates pulses when the voltage at the CK1 and CK2 clock pins changes to High from Low level (positive-edge trigger) and exceeds the threshold voltage; it sends the clock signal to the watchdog timer.

### 4. Watchdog timer

The watchdog timer can monitor two clock pulses. Short-circuit the CK1 and CK2 clock pins to monitor a single clock pulse.

### 5. Inhibition pin

The inhibition (INH) pin forces the watchdog timer on/off. When this pin is High level, the watchdog timer is stopped.

### 6. Logic circuit

The logic circuit contains flip-flops.

Flip-flop RSFF1 controls the charging and discharging of the power-on reset hold time setting capacitor ( $C_{TP}$ ).

Flip-flop RSFF2 turns on/off the circuit that accelerates charging of the power-on reset hold time setting capacitor ( $C_{TP}$ ) at a reset. The RSFF2 operates only at a reset; it does not operate at a power-on reset when the power is turned on.

## 5. Absolute Maximum Ratings

Parameter	Symbol	Conditions	Rating		Unit
			Min	Max	
Power supply voltage*	$V_{CC}$	—	-0.3	+7	V
Input voltage*	CK1	$V_{CK1}$	-0.3	+7	V
	CK2	$V_{CK2}$			
	INH	$I_{INH}$			
Reset output current	$\overline{RESET}$	$I_{OL}$ $I_{OH}$	-10	+10	mA
Allowable loss	$P_D$	$T_a \leq +85^\circ\text{C}$	—	200	mW
Storage temperature	$T_{stg}$	—	-55	+125	$^\circ\text{C}$

\*: The power supply voltage is based on the ground voltage (0 V).

### WARNING:

1. Semiconductor devices may be permanently damaged by application of stress (including, without limitation, voltage, current or temperature) in excess of absolute maximum ratings. Do not exceed any of these ratings.

## 6. Recommended Operating Conditions

Parameter	Symbol	Conditions	Value			Unit
			Min	Typ	Max	
Power supply voltage	$V_{CC}$	—	1.2	—	6.0	V
Reset ( $\overline{RESET}$ ) output current	$I_{OL}$ $I_{OH}$	—	-5	—	+5	mA
Power-on reset hold time setting capacity	$C_{TP}$	—	0.001	—	10	$\mu\text{F}$
Watchdog-timer monitoring time setting capacity*	$C_{TW}$	—	0.001	—	1	$\mu\text{F}$
Operating ambient temperature	$T_a$	—	-40	—	+85	$^\circ\text{C}$

\*: The watchdog timer monitor time range depends on the rating of the setting capacitor.

### WARNING:

1. The recommended operating conditions are required in order to ensure the normal operation of the semiconductor device. All of the device's electrical characteristics are warranted when the device is operated under these conditions.
2. Any use of semiconductor devices will be under their recommended operating condition.
3. Operation under any conditions other than these conditions may adversely affect reliability of device and could result in device failure.
4. No warranty is made with respect to any use, operating conditions or combinations not represented on this data sheet. If you are considering application under any conditions other than listed herein, please contact sales representatives beforehand.

## 7. Electrical Characteristics

### 7.1 DC Characteristics

 (V<sub>CC</sub> = +5 V, T<sub>a</sub> = +25°C)

Parameter	Symbol	Conditions	Value			Unit	
			Min	Typ	Max		
Power supply current	I <sub>CC1</sub>	After exit from reset	—	30	50	μA	
Detection voltage	V <sub>SL</sub>	V <sub>CC</sub> falling	T <sub>a</sub> = +25°C	3.60	3.70	3.80	V
			T <sub>a</sub> = -40°C to +85°C	(3.55)*	3.70	(3.85)*	
	V <sub>SH</sub>	V <sub>CC</sub> rising	T <sub>a</sub> = +25°C	3.69	3.79	3.89	V
			T <sub>a</sub> = -40°C to +85°C	(3.64)*	3.79	(3.94)*	
Detection voltage hysteresis difference	V <sub>SHYS</sub>	V <sub>SH</sub> - V <sub>SL</sub>	40	85	130	mV	
Clock-input threshold voltage	V <sub>CIH</sub>	CK rising	(1.4)*	1.9	2.5	V	
	V <sub>CIL</sub>	CK falling	0.8	1.3	(1.8)*	V	
Clock-input hysteresis	V <sub>CHTS</sub>	—	(0.4)*	0.6	(0.8)*	V	
Inhibition-input voltage	V <sub>I IH</sub>	—	3.5	—	—	V	
	V <sub>I IL</sub>	—	—	0	0.8		
Input current (CK1, CK2, INH)	I <sub>I H</sub>	V <sub>CK</sub> = 5 V	—	0	1.0	μA	
	I <sub>I L</sub>	V <sub>CK</sub> = 0 V	-1.0	0	—	μA	
Reset output voltage	V <sub>OH</sub>	I <sub>RESET</sub> = -5 mA	4.5	4.75	—	V	
	V <sub>OL</sub>	I <sub>RESET</sub> = +5 mA	—	0.12	0.4	V	
Reset-output minimum power voltage	V <sub>CCL</sub>	I <sub>RESET</sub> = +50 μA	—	0.8	1.2	V	

\*: The values enclosed in parentheses ( ) are setting assurance values.

## 7.2 AC Characteristics

 (V<sub>CC</sub> = +5 V, Ta = +25°C)

Parameter	Symbol	Conditions	Value			Unit	
			Min	Typ	Max		
Power-on reset hold time	t <sub>PR</sub>	C <sub>TP</sub> = 0.1 μF	80	130	180	ms	
V <sub>CC</sub> input pulse width	t <sub>PI</sub>	C <sub>TP</sub> = 0.1 μF	(110)*2	—	—	μs	
V <sub>CC</sub> delay time	t <sub>PD</sub>	C <sub>TP</sub> = 0.1 μF	—	20	(100)*2	μs	
Watchdog timer reset time	t <sub>WD</sub>	C <sub>TW</sub> = 0.01 μF, C <sub>TP</sub> = 0.1 μF	7.5	15	22.5	ms	
Watchdog timer reset time	t <sub>WR</sub>	C <sub>TP</sub> = 0.1 μF	5	10	15	ms	
Clock input pulse width	t <sub>CKW</sub>	—	500	—	—	ns	
Clock input pulse cycle	t <sub>CKT</sub>	—	20	—	—	μs	
Reset ( $\overline{\text{RESET}}$ ) output transition time*1	Rising	t <sub>r</sub> *1	C <sub>L</sub> = 50 pF	—	—	500	ns
	Falling	t <sub>f</sub> *2	C <sub>L</sub> = 50 pF	—	—	500	ns

\*1: The voltage range is 10% to 90% at testing the reset output transition time.

\*2: The values enclosed in parentheses ( ) are setting assurance values.

## 8. Diagram

### 8.1 Basic operation (Positive clock pulse)

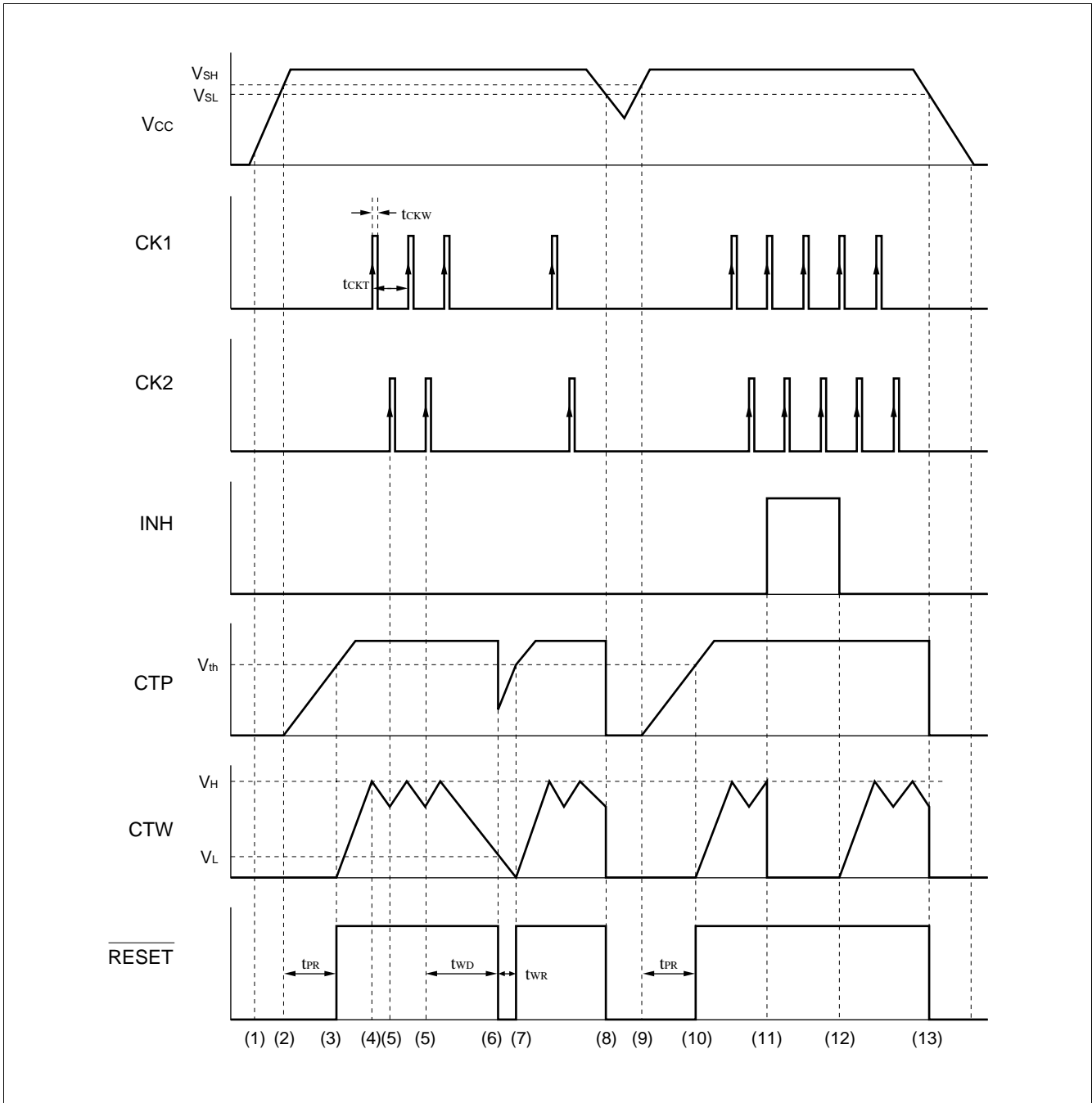

## 8.2 Basic operation (Negative clock pulse)

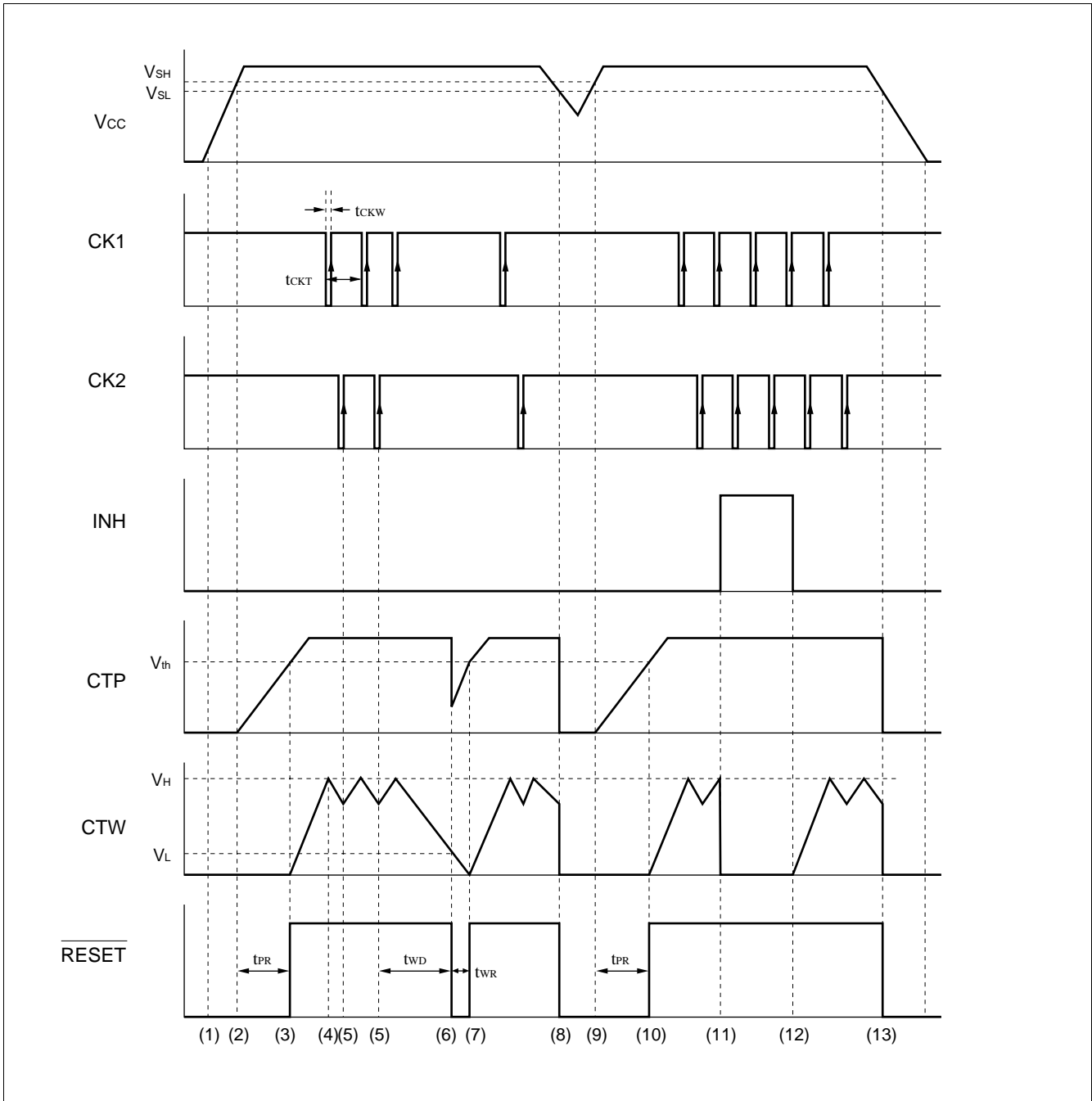

### 8.3 Single-clock input monitoring (Positive clock pulse)

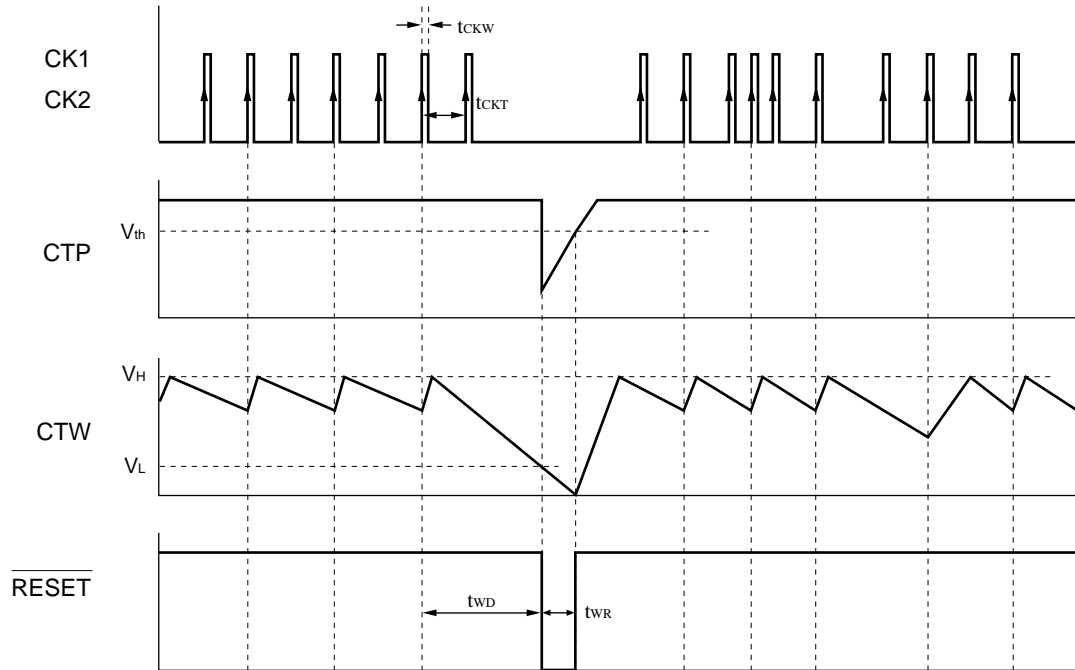

Note: The MB3793 can monitor only one clock.  
 The MB3793 checks the clock signal at every other input pulse. Therefore, set watchdog timer monitor time  $t_{WD}$  to the time that allows the MB3793 to monitor the period twice as long as the input clock pulse.

### 8.4 Inhibition operation (Positive clock pulse)

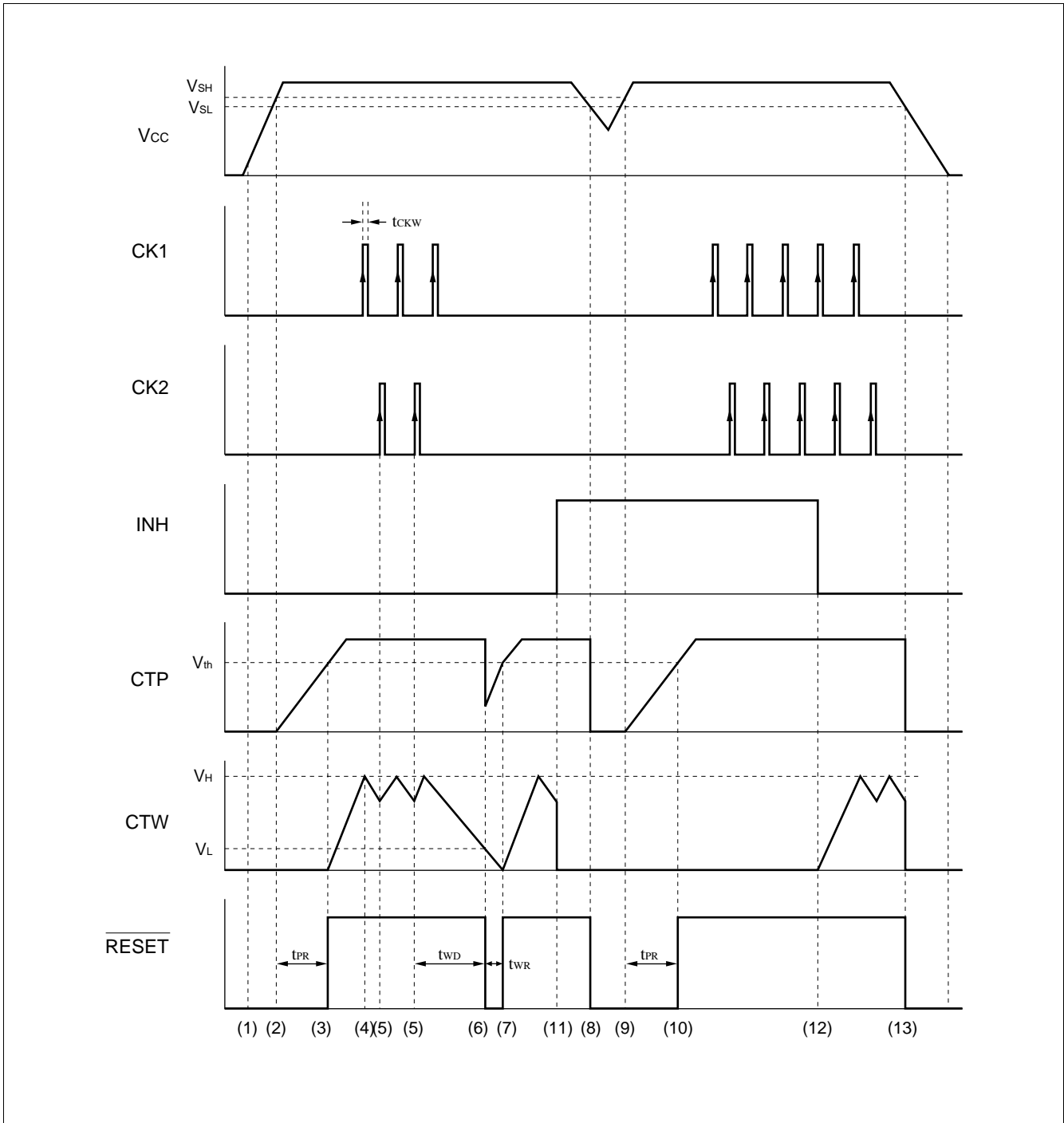

## 8.5 Clock pulse input supplementation (Positive clock pulse)

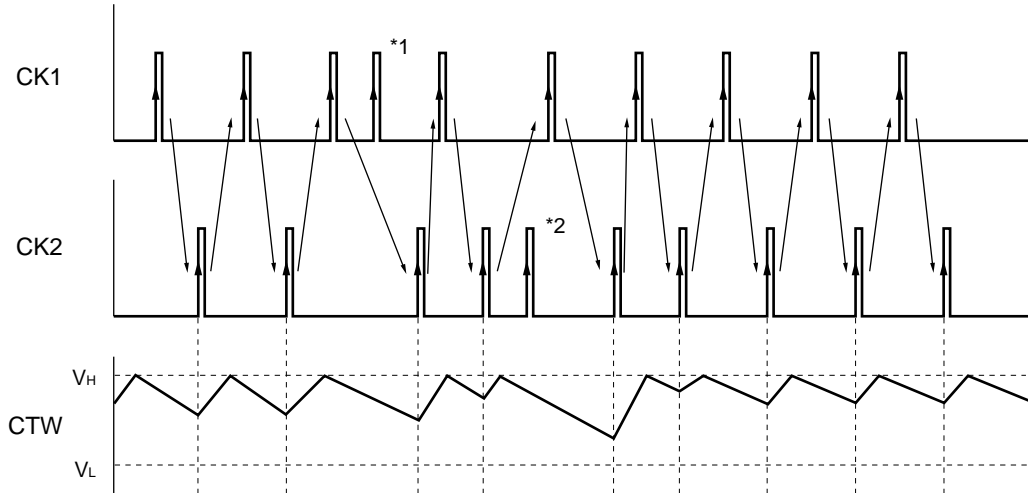

Note: The MB3793 watchdog timer monitors Clock1 (CK1) and Clock2 (CK2) pulses alternately. When a CK2 pulse is detected after detecting a CK1 pulse, the monitoring time setting capacity ( $C_{TW}$ ) switches to charging from discharging. When two consecutive pulses occur on one side of this alternation before switching, the second pulse is ignored. In the above figure, pulse \*1 and \*2 are ignored.

## 9. Operation Sequence

### 1. Positive clock pulse input

See “1. Basic operation (positive clock pulse)” under “Diagram”

### 2. Negative clock pulse input

See “2. Basic operation (negative clock pulse)” under “Diagram”

The MB3793 operates in the same way whether it inputs positive or negative pulses.

### 3. Clock monitoring

To use the MB3793 while monitoring only one clock, connect clock pins CK1 and CK2.

Although the MB3793 operates basically in the same way as when monitoring two clocks, it monitors the clock signal at every other input pulse.

See “3. Single-clock input monitoring (positive clock pulse)” under “Diagram”

#### 4. Description of Operations

The numbers given to the following items correspond to numbers (1) to (13) used in “Diagram”

- (1) The MB3793 outputs a reset signal when the supply voltage ( $V_{CC}$ ) reaches about 0.8 V ( $V_{CCL}$ )
- (2) If  $V_{CC}$  reaches or exceeds the rise-time detected voltage  $V_{SH}$ , the MB3793 starts charging the power-on reset hold time setting capacitor  $C_{TP}$ . At this time, the output remains in a reset state. The  $V_{SH}$  value is about 3.79 V.
- (3) When  $C_{TP}$  has been charged for a certain period of time  $t_{PR}$  (until the  $\overline{CTP}$  pin voltage exceeds the threshold voltage ( $V_{th}$ ) after the start of charging), the MB3793 cancels the reset (setting the  $\overline{RESET}$  pin to “H” level from “L” level). The  $V_{th}$  value is about 3.6 V with  $V_{CC} = 5.0$  V

The power-on reset hold timer monitor time  $t_{PR}$  is set with the following equation:

$$t_{PR} \text{ (ms)} \approx A \times C_{TP} \text{ (\mu F)}$$

The value of A is about 1300 with  $V_{CC} = 5.0$  V. The MB3793 also starts charging the watchdog timer monitor time setting capacitor ( $C_{TW}$ ).

- (4) When the voltage at the watchdog timer monitor time setting pin  $CTW$  reaches the “H” level threshold voltage  $V_H$ , the  $C_{TW}$  switches from the charge state to the discharge state.  
The value of  $V_H$  is always about 1.24 V regardless of the detected voltage.
- (5) If the CK2 pin inputs a clock pulse (positive edge trigger) when the  $C_{TW}$  is being discharged in the CK1-CK2 order or simultaneously, the  $C_{TW}$  switches from the discharge state to the charge state.  
The MB3793 repeats operations (4) and (5) as long as the CK1/CK2 pin inputs clock pulses with the system logic circuit operating normally.
- (6) If no clock pulse is fed to the CK1 or CK2 pin within the watchdog timer monitor time  $t_{WD}$  due to some problem with the system logic circuit, the  $CTW$  pin is set to the “L” level threshold voltage  $V_L$  or less and the MB3793 outputs a reset signal (setting the  $\overline{RESET}$  pin to “L” level from “H” level).  
The value of  $V_L$  is always about 0.24 V regardless of the detected voltage.

The watchdog timer monitor time  $t_{WD}$  is set with the following equation:

$$t_{WD} \text{ (ms)} \approx B \times C_{TW} \text{ (\mu F)}$$

The value of B is hardly affected by the supply voltage; it is about 1500 with  $V_{CC} = 5.0$  V.

- (7) When a certain period of time  $t_{WR}$  has passed (until the  $CTP$  pin voltage reaches or exceeds  $V_{th}$  again after recharging the  $C_{TP}$ ), the MB3793 cancels the reset signal and starts operating the watchdog timer.  
The watchdog timer monitor reset time  $t_{WR}$  is set with the following equation:  
 $t_{WR} \text{ (ms)} \approx D \times C_{TP} \text{ (\mu F)}$   
The value of D is about 100 with  $V_{CC} = 5.0$  V.  
The MB3793 repeats operations (4) and (5) as long as the CK1/CK2 pin inputs clock pulses. If no clock pulse is input, the MB3793 repeats operations (6) and (7).
- (8) If  $V_{CC}$  is lowered to the fall-time detected voltage ( $V_{SL}$ ) or less, the  $CTP$  pin voltage decreases and the MB3793 outputs a reset signal (setting the  $\overline{RESET}$  pin to “L” level from “H” level).  
The value of  $V_{SL}$  is 3.7 V
- (9) When  $V_{CC}$  reaches or exceeds  $V_{SH}$  again, the MB3793 starts charging the  $C_{TP}$ .
- (10) When the  $CTP$  pin voltage reaches or exceeds  $V_{th}$ , the MB3793 cancels the reset and restarts operating the watchdog timer. It repeats operations (4) and (5) as long as the CK1/CK2 pin inputs clock pulses.
- (11) Making the inhibit pin active (setting the INH pin to “H” from “L”) forces the watchdog timer to stop operation. This stops only the watchdog timer, leaving the MB3793 monitoring  $V_{CC}$  (operations (8) to (10)).  
The watchdog timer remains inactive unless the inhibit input is canceled.
- (12) Canceling the inhibit input (setting the INH pin to “L” from “H”) restarts the watchdog timer.
- (13) The reset signal is output when the power supply is turned off to set  $V_{CC}$  to  $V_{SL}$  or less.

### 10. Typical Characteristics

Power supply current-Power supply voltage

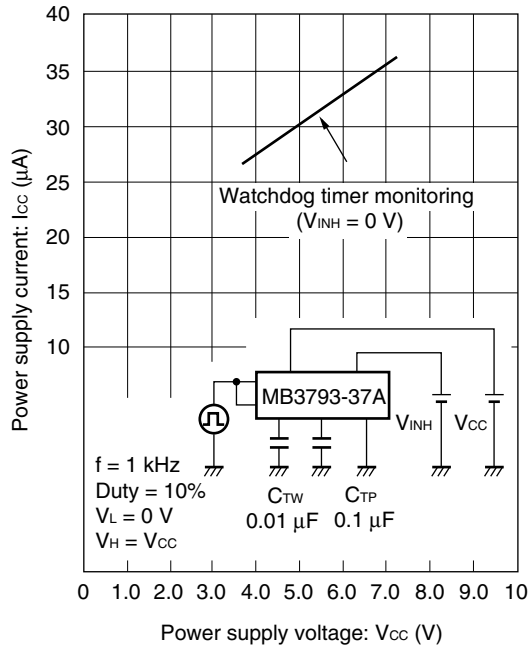

Detection voltage - Operating ambient temperature

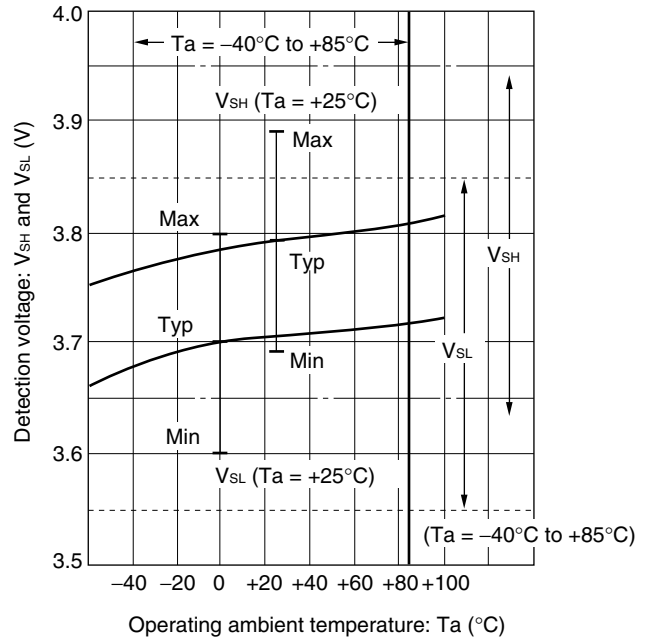

Reset output voltage-Reset output current (P-MOS side)

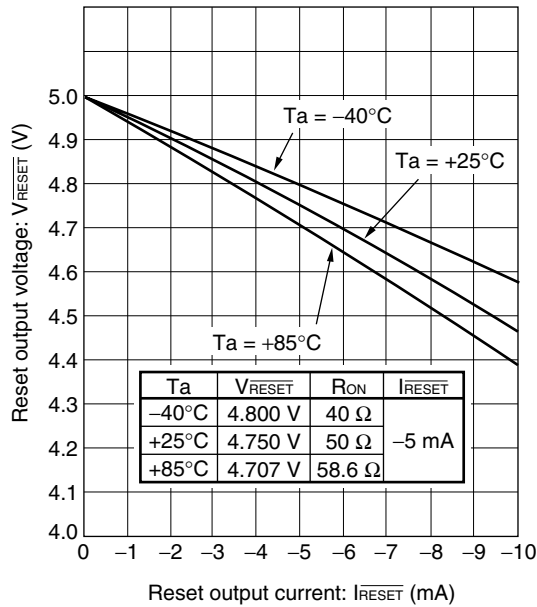

Reset output voltage-Reset output current (N-MOS side)

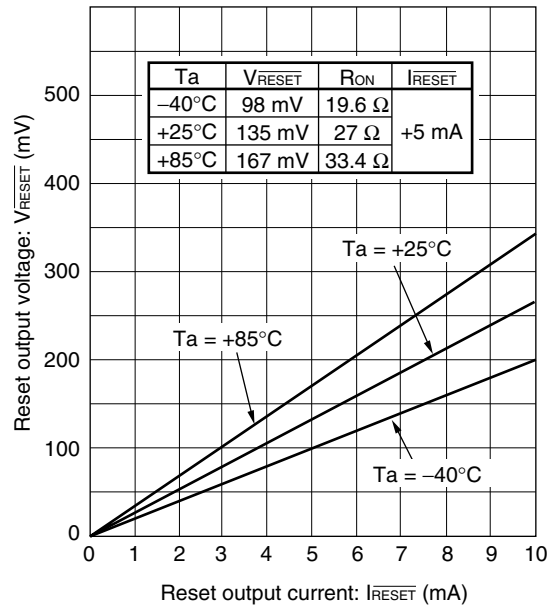

Reset output voltage -  
Power supply voltage

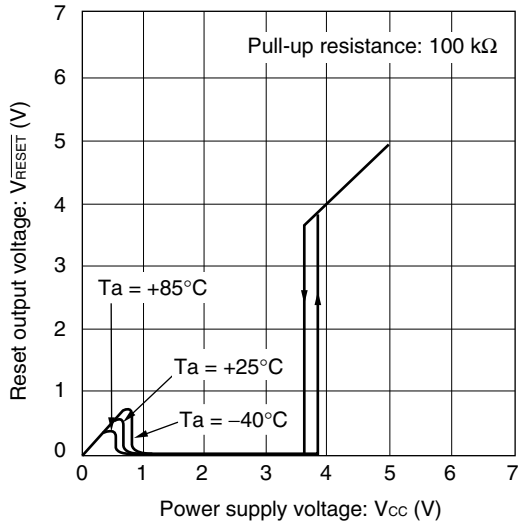

Reset-on reset time -  
Operating ambient temperature  
(when  $V_{\text{CC}}$  rising)

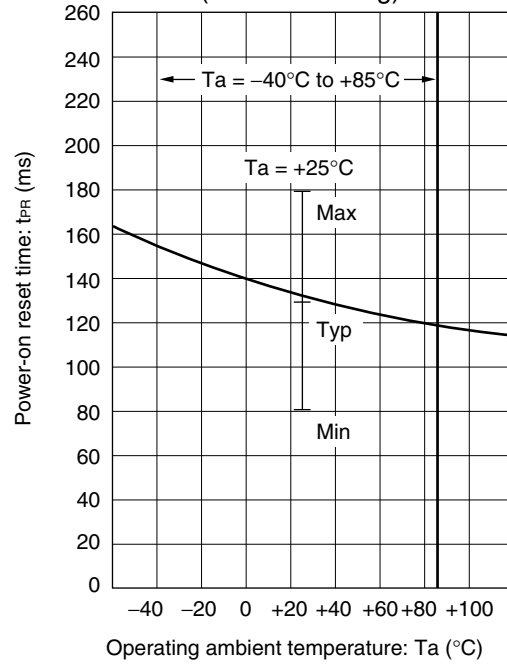

Watchdog timer reset time -  
Operating ambient temperature  
(when monitoring)

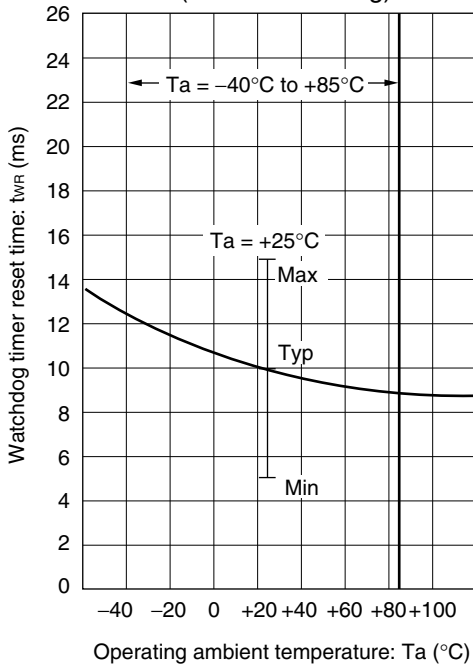

Watchdog timer monitoring time -  
Operating ambient temperature

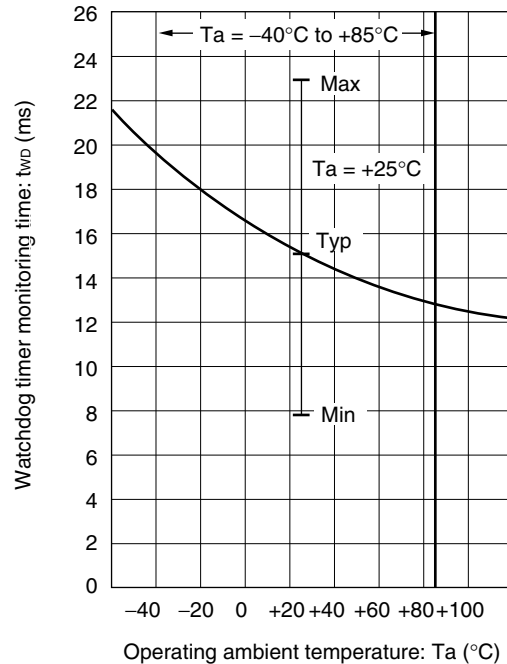

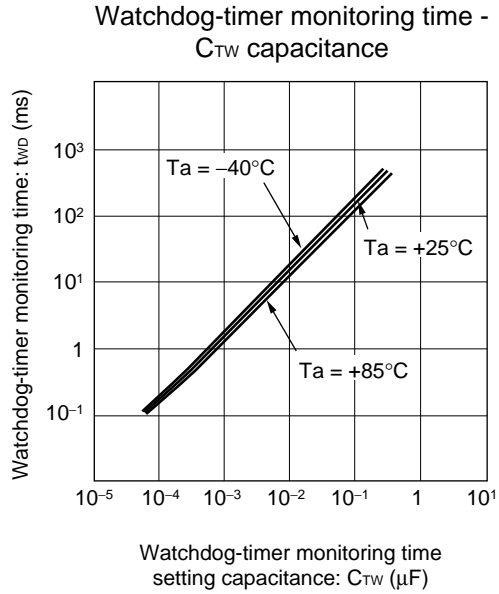
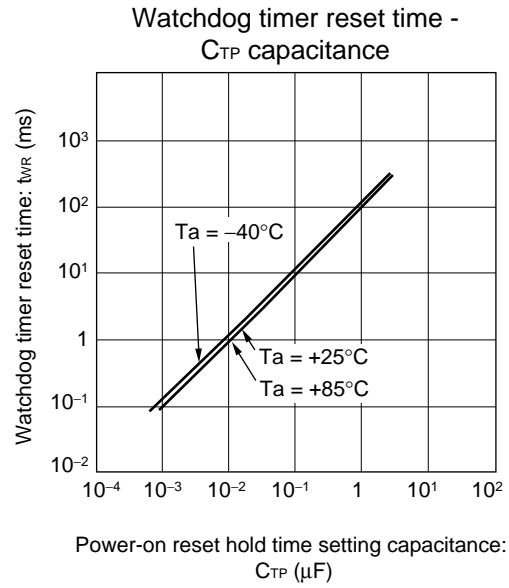
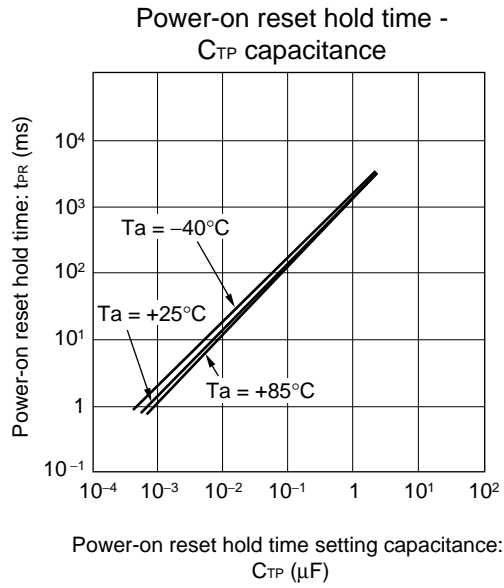

## 11. Application Example

### 11.1 Supply voltage monitor and watchdog timer (1-clock monitor)

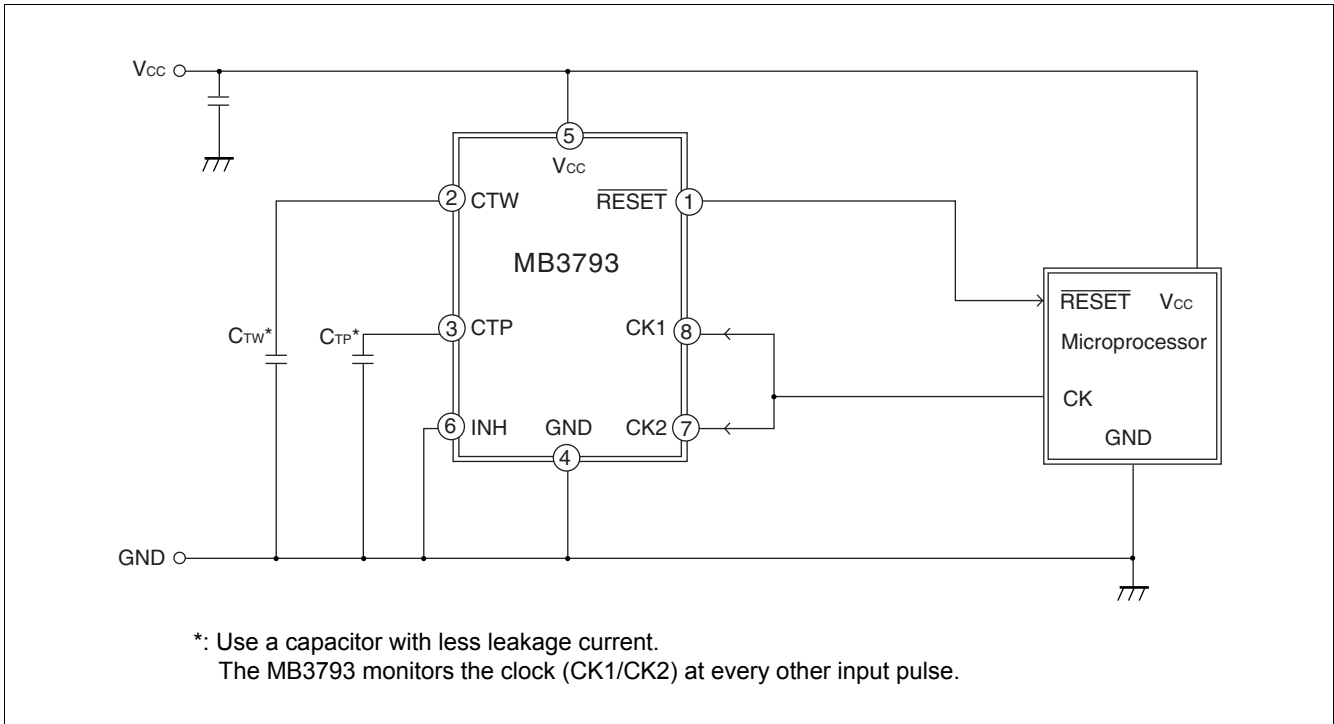

## 11.2 Supply voltage monitor and watchdog timer stop

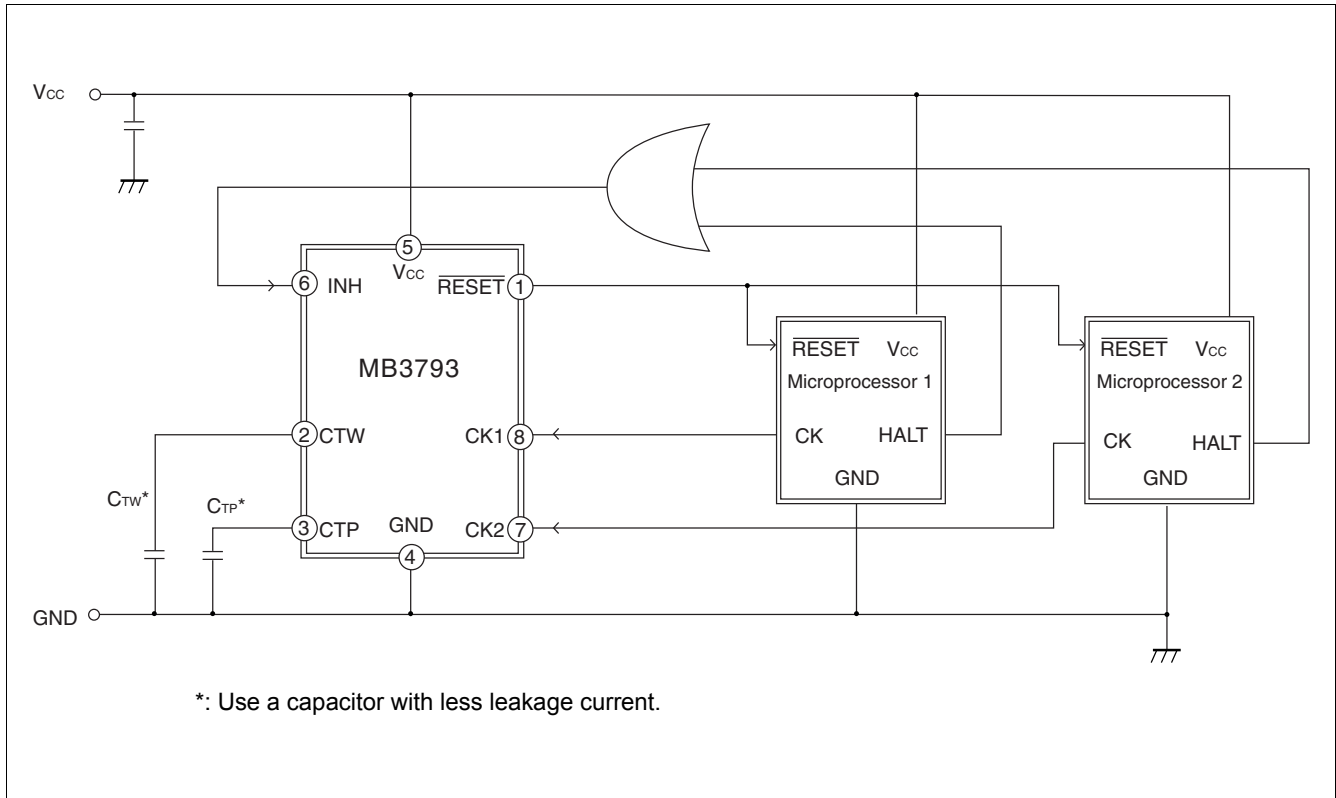

## 12. Typical Application

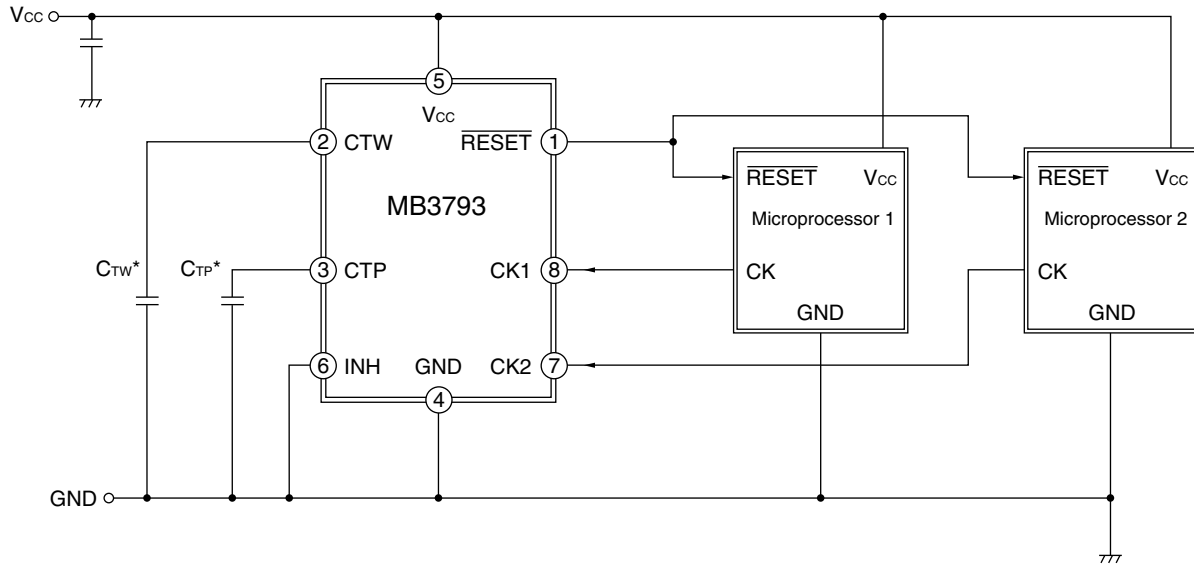

\*: Use a capacitor with less leakage current.

### 1. Equation of time-setting capacitances ( $C_{TP}$ and $C_{TW}$ ) and set time

$$t_{PR} \text{ [ms]} \approx A \times C_{TP} \text{ [\mu F]}$$

$$t_{WD} \text{ [ms]} \approx B \times C_{TW} \text{ [\mu F]} + C \times C_{TP} \text{ [\mu F]}$$

However, when  $\frac{C_{TP}}{C_{TW}} \leq$  about 10,  $t_{WD} \text{ [ms]} \approx B \times C_{TW} \text{ [\mu F]}$

$$t_{WR} \text{ [ms]} \approx D \times C_{TP} \text{ [\mu F]}$$

Values of A, B, C, and D

A	B	C	D	Remark
1300	1500	0	100	$V_{CC} = 5.0 \text{ V}$

### 2. (Example) when $C_{TP} = 0.1 \text{ }\mu\text{F}$ and $C_{TW} = 0.01 \text{ }\mu\text{F}$

time (ms)	$t_{PR}$	$\approx 130$
	$t_{WD}$	$\approx 15$
	$t_{WR}$	$\approx 10$

### 13. Notes On Use

- Take account of common impedance when designing the earth line on a printed wiring board.
- Take measures against static electricity.
  - For semiconductors, use antistatic or conductive containers.
  - When storing or carrying a printed circuit board after chip mounting, put it in a conductive bag or container.
  - The work table, tools and measuring instruments must be grounded.
  - The worker must put on a grounding device containing 250 kΩ to 1 MΩ resistors in series.
- Do not apply a negative voltage
  - Applying a negative voltage of -0.3 V or less to an LSI may generate a parasitic transistor, resulting in malfunction.

### 14. Ordering Information

Part number	Package	Remarks
MB3793-37APF-□□□	8-pin Plastic SOP (FPT-8P-M01)	conventional version
MB3793-37APNF-□□□	8-pin Plastic SOP (FPT-8P-M02)	conventional version
MB3793-37APF-□□□E1	8-pin Plastic SOP (FPT-8P-M01)	Lead Free version
MB3793-37APNF-□□□E1	8-pin Plastic SOP (FPT-8P-M02)	Lead Free version

### 15. RoHS Compliance Information of Lead (Pb) Free version

The LSI products of Cypress with “E1” are compliant with RoHS Directive , and has observed the standard of lead, cadmium, mercury, Hexavalent chromium, polybrominated biphenyls (PBB) , and polybrominated diphenyl ethers (PBDE) .

The product that conforms to this standard is added “E1” at the end of the part number.

## 16. Marking Format (Lead Free version)

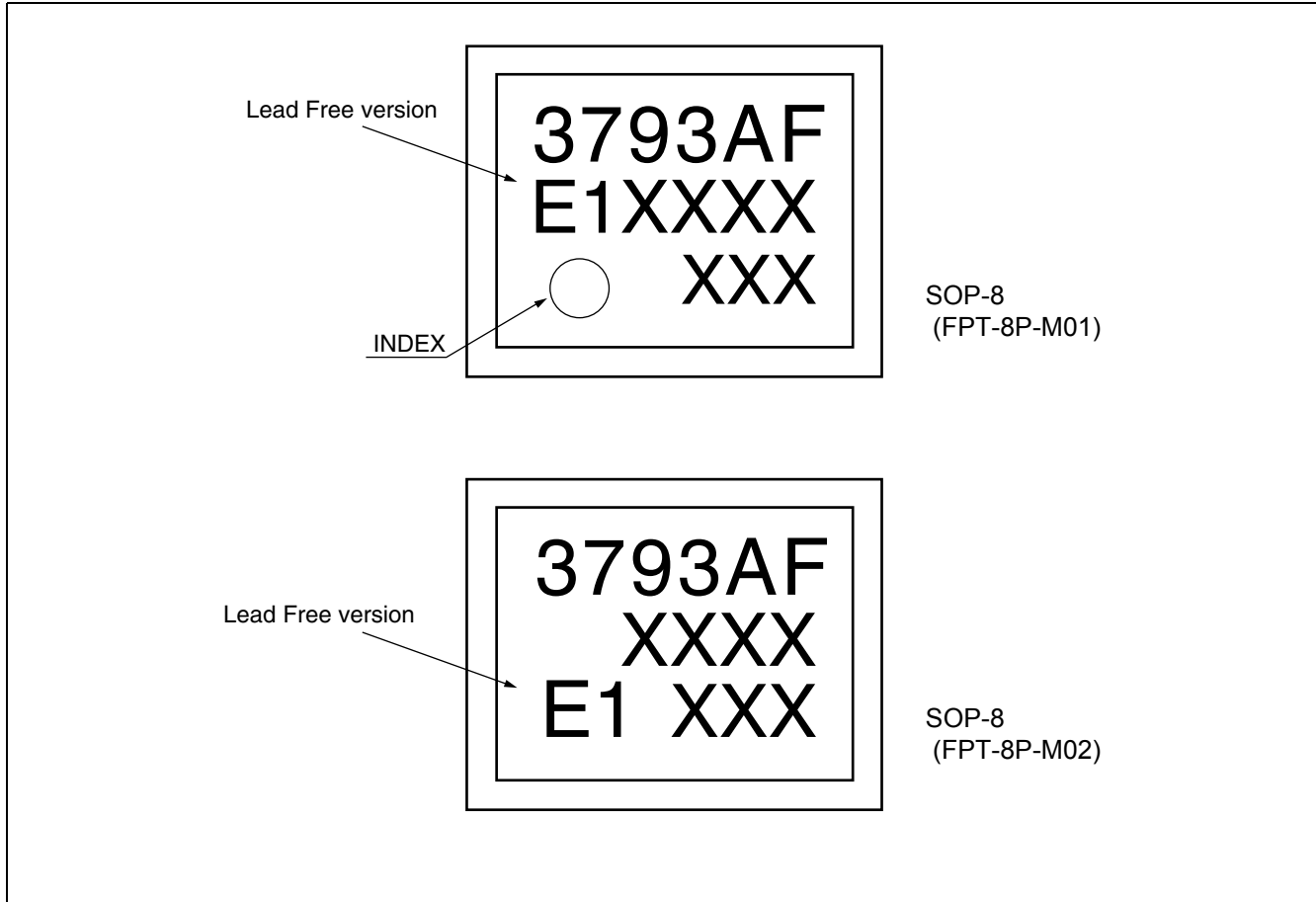

17. Labeling Sample (Lead free version)

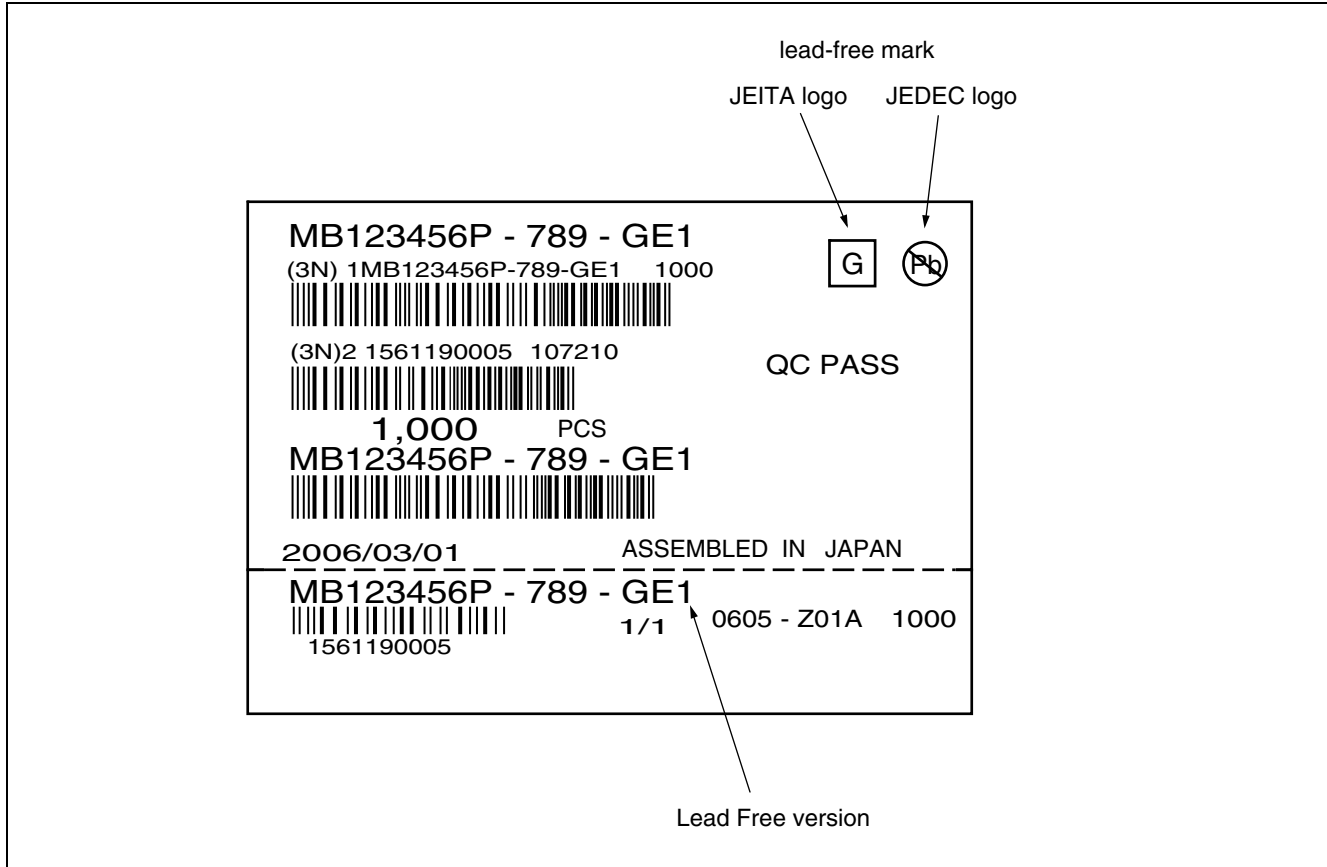

The diagram shows a rectangular label with the following text and markings:

- Top line: **MB123456P - 789 - GE1**
- Second line: **(3N) 1MB123456P-789-GE1 1000**
- Barcode
- Third line: **(3N)2 1561190005 107210**
- Barcode
- Fourth line: **1,000 PCS**
- Fifth line: **MB123456P - 789 - GE1**
- Barcode
- Sixth line: **2006/03/01** (left) and **ASSEMBLED IN JAPAN** (right)
- Horizontal dashed line
- Bottom section: **MB123456P - 789 - GE1**
- Bottom left: **1561190005**
- Bottom middle: **1/1**
- Bottom right: **0605 - Z01A 1000**

Annotations and logos:

- JEITA logo**: A square box containing the letter **G**.
- JEDEC logo**: A circle containing a crossed-out **Pb**.
- lead-free mark**: Points to the JEDEC logo.
- QC PASS**: Text located to the right of the middle barcodes.
- Lead Free version**: An arrow points to the **1/1** marking.



**(2) Manual soldering (partial heating method)**

Conditions : Max Temperature 400°C

Times : 5 s max/pin

### 19. Package Dimensions

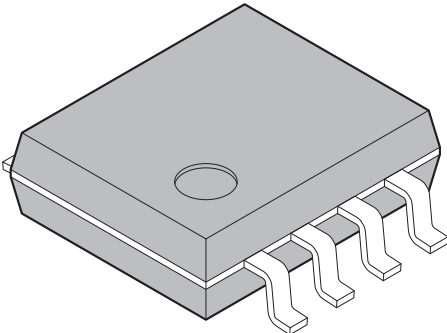
<p style="text-align: center;">8-pin plastic SOP</p>  <p style="text-align: center;">(FPT-8P-M01)</p>	Lead pitch	1.27 mm
	Package width × package length	5.3 × 6.35 mm
	Lead shape	Gullwing
	Sealing method	Plastic mold
	Mounting height	2.25 mm MAX
	Weight	0.10 g
	Code (Reference)	P-SOP8-5.3×6.35-1.27

8-pin plastic SOP  
(FPT-8P-M01)

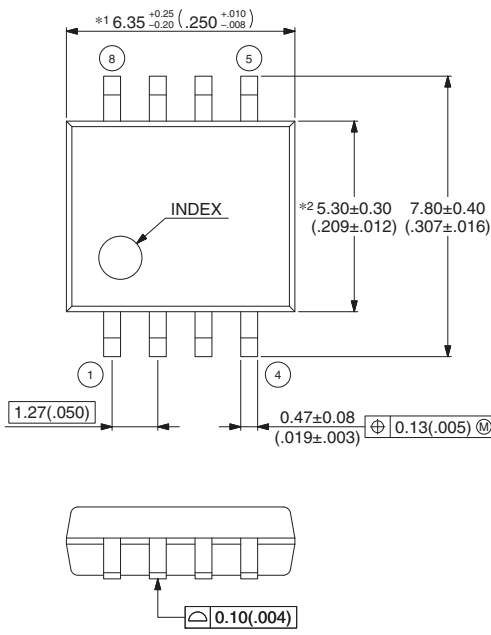

Note 1) \*1 : These dimensions include resin protrusion.  
 Note 2) \*2 : These dimensions do not include resin protrusion.  
 Note 3) Pins width and pins thickness include plating thickness.  
 Note 4) Pins width do not include tie bar cutting remainder.

Dimensions in mm (inches).  
 Note: The values in parentheses are reference values.

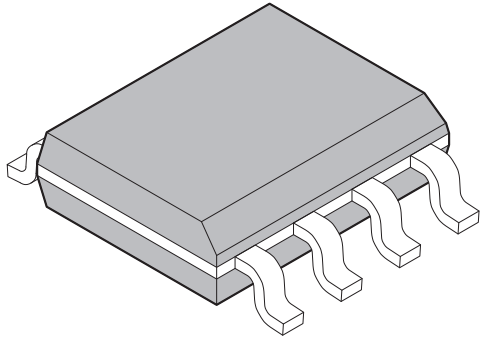
<p style="text-align: center;">8-pin plastic SOP</p>  <p style="text-align: center;">(FPT-8P-M02)</p>	Lead pitch	1.27 mm
	Package width × package length	3.9 mm × 5.05 mm
	Lead shape	Gullwing
	Sealing method	Plastic mold
	Mounting height	1.75 mm MAX
	Weight	0.06 g

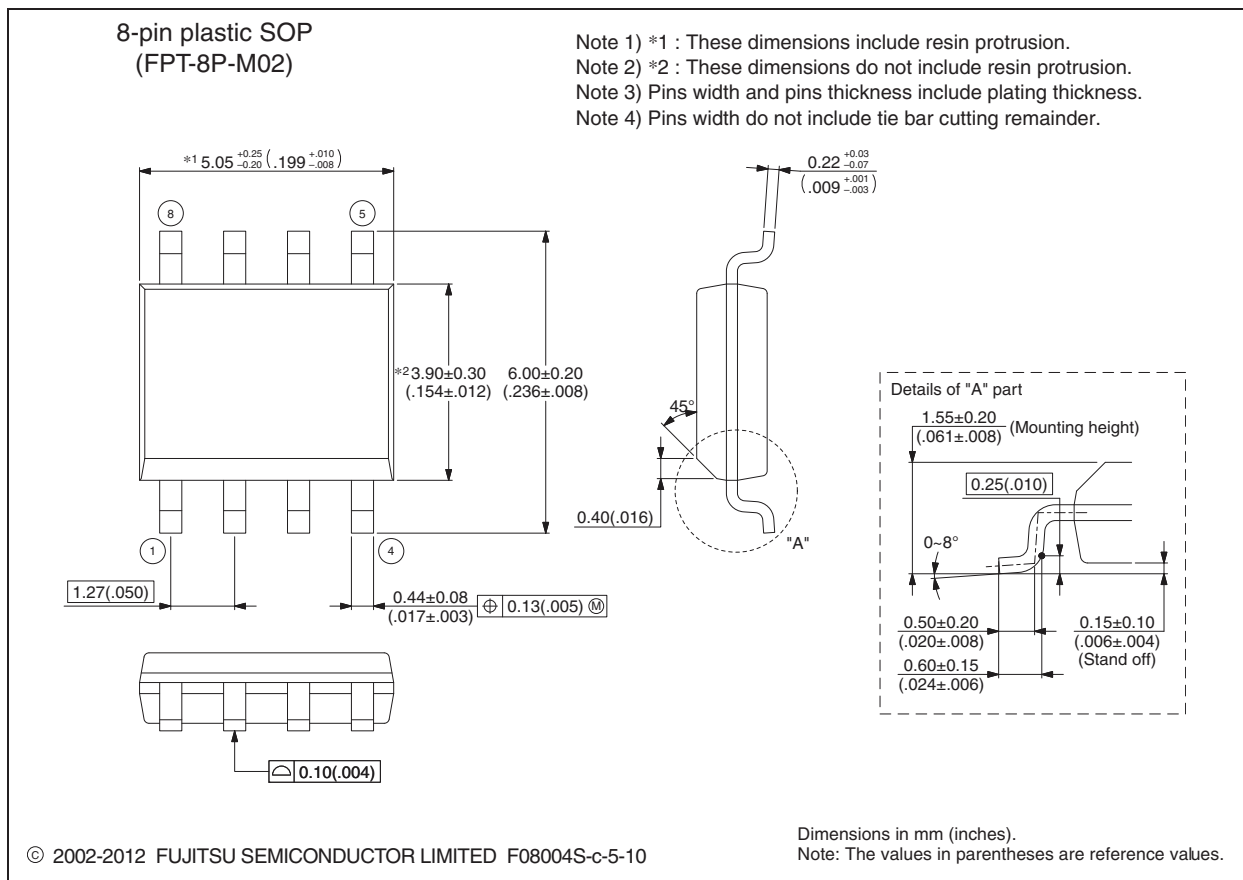

## 20. Major Changes

Spanson Publication Number: MB3793-37A\_DS04-27403

Page	Section	Change Results
Revision 5.0		
-	-	Company name and layout design change
1	Description	Deleted "There is also a mask option that can detect voltages of 4.9 V to 2.4 V in 0.1-V steps."

**NOTE:** Please see "Document History" about later revised information.

## Document History

Document Title: MB3793-37A Power Voltage Monitoring IC with Watchdog Timer Datasheet Document Number: 002-08517				
Revision	ECN	Orig. of Change	Submission Date	Description of Change
**	—	TAOA	01/30/2015	Migrated to Cypress and assigned document number 002-08517. No change to document contents or format.
*A	5175893	TAOA	03/15/2016	Updated to Cypress template

## Sales, Solutions, and Legal Information

### Worldwide Sales and Design Support

Cypress maintains a worldwide network of offices, solution centers, manufacturer's representatives, and distributors. To find the office closest to you, visit us at [Cypress Locations](#).

#### Products

ARM® Cortex® Microcontrollers	<a href="http://cypress.com/arm">cypress.com/arm</a>
Automotive	<a href="http://cypress.com/automotive">cypress.com/automotive</a>
Clocks & Buffers	<a href="http://cypress.com/clocks">cypress.com/clocks</a>
Interface	<a href="http://cypress.com/interface">cypress.com/interface</a>
Lighting & Power Control	<a href="http://cypress.com/powerpsoc">cypress.com/powerpsoc</a>
Memory	<a href="http://cypress.com/memory">cypress.com/memory</a>
PSoC	<a href="http://cypress.com/psoc">cypress.com/psoc</a>
Touch Sensing	<a href="http://cypress.com/touch">cypress.com/touch</a>
USB Controllers	<a href="http://cypress.com/usb">cypress.com/usb</a>
Wireless/RF	<a href="http://cypress.com/wireless">cypress.com/wireless</a>

#### PSoC® Solutions

[cypress.com/psoc](http://cypress.com/psoc)  
PSoC 1 | PSoC 3 | PSoC 4 | PSoC 5LP

#### Cypress Developer Community

[Community](#) | [Forums](#) | [Blogs](#) | [Video](#) | [Training](#)

#### Technical Support

[cypress.com/support](http://cypress.com/support)

© Cypress Semiconductor Corporation 2001-2016. This document is the property of Cypress Semiconductor Corporation and its subsidiaries, including Spansion LLC ("Cypress"). This document, including any software or firmware included or referenced in this document ("Software"), is owned by Cypress under the intellectual property laws and treaties of the United States and other countries worldwide. Cypress reserves all rights under such laws and treaties and does not, except as specifically stated in this paragraph, grant any license under its patents, copyrights, trademarks, or other intellectual property rights. If the Software is not accompanied by a license agreement and you do not otherwise have a written agreement with Cypress governing the use of the Software, then Cypress hereby grants you under its copyright rights in the Software, a personal, non-exclusive, nontransferable license (without the right to sublicense) (a) for Software provided in source code form, to modify and reproduce the Software solely for use with Cypress hardware products, only internally within your organization, and (b) to distribute the Software in binary code form externally to end users (either directly or indirectly through resellers and distributors), solely for use on Cypress hardware product units. Cypress also grants you a personal, non-exclusive, nontransferable, license (without the right to sublicense) under those claims of Cypress's patents that are infringed by the Software (as provided by Cypress, unmodified) to make, use, distribute, and import the Software solely to the minimum extent that is necessary for you to exercise your rights under the copyright license granted in the previous sentence. Any other use, reproduction, modification, translation, or compilation of the Software is prohibited.

CYPRESS MAKES NO WARRANTY OF ANY KIND, EXPRESS OR IMPLIED, WITH REGARD TO THIS DOCUMENT OR ANY SOFTWARE, INCLUDING, BUT NOT LIMITED TO, THE IMPLIED WARRANTIES OF MERCHANTABILITY AND FITNESS FOR A PARTICULAR PURPOSE. Cypress reserves the right to make changes to this document without further notice. Cypress does not assume any liability arising out of the application or use of any product or circuit described in this document. Any information provided in this document, including any sample design information or programming code, is provided only for reference purposes. It is the responsibility of the user of this document to properly design, program, and test the functionality and safety of any application made of this information and any resulting product. Cypress products are not designed, intended, or authorized for use as critical components in systems designed or intended for the operation of weapons, weapons systems, nuclear installations, life-support devices or systems, other medical devices or systems (including resuscitation equipment and surgical implants), pollution control or hazardous substances management, or other uses where the failure of the device or system could cause personal injury, death, or property damage ("Unintended Uses"). A critical component is any component of a device or system whose failure to perform can be reasonably expected to cause the failure of the device or system, or to affect its safety or effectiveness. Cypress is not liable, in whole or in part, and Company shall and hereby does release Cypress from any claim, damage, or other liability arising from or related to all Unintended Uses of Cypress products. Company shall indemnify and hold Cypress harmless from and against all claims, costs, damages, and other liabilities, including claims for personal injury or death, arising from or related to any Unintended Uses of Cypress products.

Cypress, the Cypress logo, Spansion, the Spansion logo, and combinations thereof, PSoC, CapSense, EZ-USB, F-RAM, and Traveo are trademarks or registered trademarks of Cypress in the United States and other countries. For a more complete list of Cypress trademarks, visit [cypress.com](http://cypress.com). Other names and brands may be claimed as property of their respective owners.

## Looking for pricing, stock, or lifecycle information?

Click below to explore more details on WIN SOURCE:

-  [View MB3793-37APNF-G-JN-ER6E1 on WIN SOURCE](#)
-  [Cypress Semiconductor Corp Information](#)

## Optimize Your Supply Chain with WIN SOURCE Solutions

-  Global Sourcing Solution
-  Obsolete Management
-  Cost Control Management
-  Shortage Management
-  Alternative Solution
-  Excess Inventory Management