



**THE DATASHEET OF
MB3793-28APNF-G-JN-EF6E1**





THIS SPEC IS OBSOLETE

Spec No: 002-08559

Spec Title: MB3793-28A POWER-VOLTAGE MONITORING
IC WITH WATCHDOG TIMER DATASHEET

Replaced by: NONE

Power-Voltage Monitoring IC with Watchdog Timer Datasheet

Description

The MB3793 is an integrated circuit to monitor power voltage; it incorporates a watchdog timer. A reset signal is output when the power is cut or falls abruptly. When the power recovers normally after resetting, a power-on reset signal is output to microprocessor units (MPUs). An internal watchdog timer with two inputs for system operation diagnosis can provide a fail-safe function for various application systems.

Model No.	Marking Code	Detection voltage
MB3793-28A	3793AR	2.8 V

Features

- Precise detection of power voltage fall: $\pm 2.5\%$
- Detection voltage with hysteresis
- Low power dispersion: $I_{CC} = 41 \mu\text{A}$ (Typ)
- Internal dual-input watchdog timer
- Watchdog timer halt function
- Independently-set watchdog and reset times

Application

- Arcade Amusement etc.

Contents

Description	1	8.4 Inhibition operation (Positive clock pulse)	11
Features	1	8.5 Clock pulse input supplementation (Positive clock pulse)	12
Application	1	9. Operation Sequence	13
Contents	2	9.1 Positive clock pulse input	13
1. Pin Assignment	3	9.2 Negative clock pulse input	13
2. Pin Description	3	9.3 Single-clock input monitoring	13
3. Block Diagram	4	9.4 Description of Operations	13
4. Block Functions	5	10. Typical Characteristics	15
4.1 Comp. S	5	11. Application Example	18
4.2 Output circuit	5	11.1 Supply voltage monitor and watchdog timer	18
4.3 Pulse generator	5	11.2 Supply voltage monitor and watchdog timer stop	19
4.4 Watchdog timer	5	11.3 Setting of compulsory reset	19
4.5 Logic circuit	5	12. Usage Precaution	20
5. Absolute Maximum Ratings	6	13. Ordering Information	20
6. Recommended Operating Conditions	6	14. RoHS Compliance Information of Lead (Pb) Free version	20
7. Electrical Characteristics	7	15. Package Dimensions	21
7.1 DC Characteristics	7	16. Document History	22
7.2 AC Characteristics	7	Sales, Solutions, and Legal Information	23
8. Timing Diagram	8		
8.1 Basic operation (Positive clock pulse)	8		
8.2 Basic operation (Negative clock pulse)	9		
8.3 Single-clock input monitoring (Positive clock pulse)	10		

1. Pin Assignment

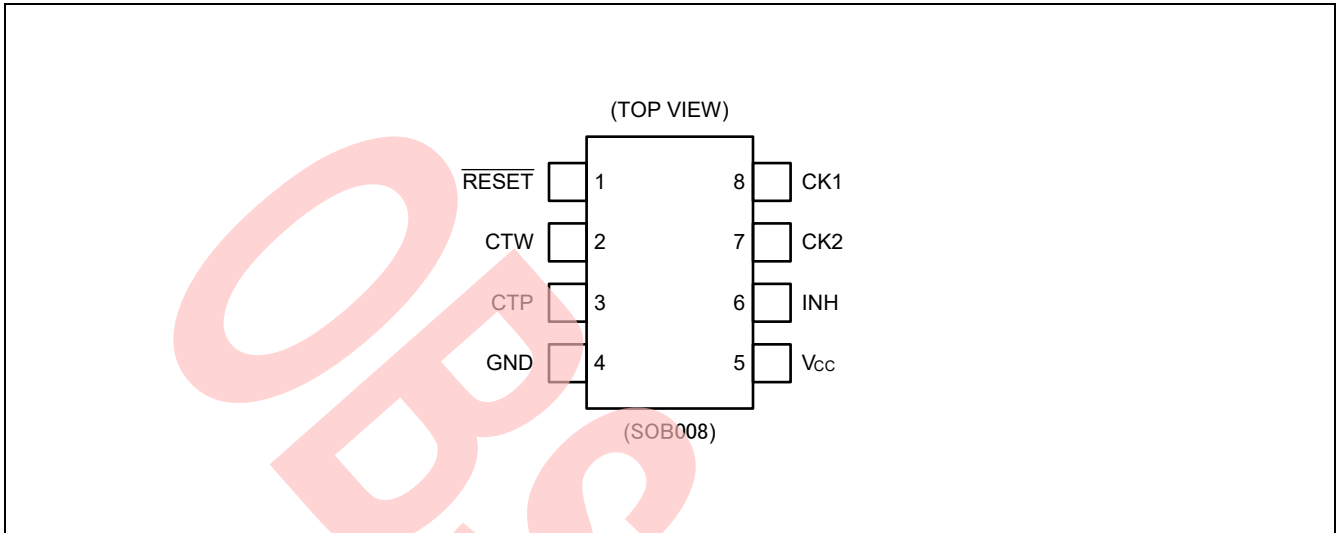

2. Pin Description

Pin No.	Symbol	Description
1	$\overline{\text{RESET}}$	Outputs reset pin
2	CTW	Sets watchdog timer monitoring time pin
3	CTP	Sets power-on reset hold time pin
4	GND	Ground pin
5	VCC	Power supply pin
6	INH	This pin forces the watchdog timer on/off. When this pin is High level, the watchdog timer is stopped.
7	CK2	Inputs clock 2 pin
8	CK1	Inputs clock 1 pin

3. Block Diagram

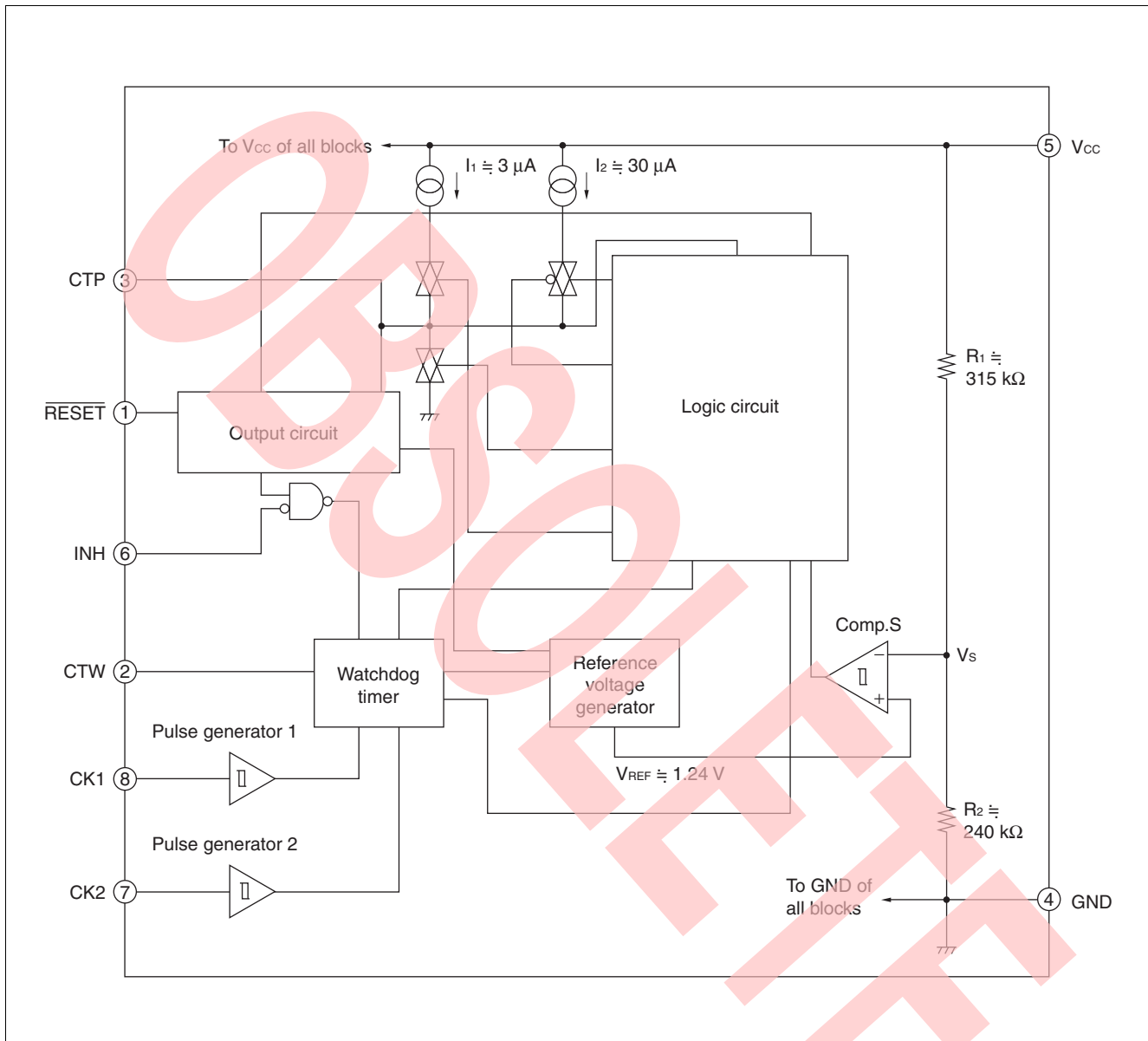

4. Block Functions

4.1 Comp. S

Comp. S is a comparator with hysteresis to compare the reference voltage with a voltage (V_s) that is the result of dividing the power voltage (V_{cc}) by resistors R_1 and R_2 . When V_s falls below 1.24 V, a reset signal is output. This function enables the MB3793 to detect an abnormality within 1 μ s when the power is cut or falls abruptly.

4.2 Output Circuit

The output circuit has a comparator to control the reset signal ($\overline{\text{RESET}}$) output. When the voltage at the CTP pin for setting the power-on reset hold time exceeds the threshold voltage, resetting is canceled.

Since the reset ($\overline{\text{RESET}}$) output buffer has the CMOS organization, no pull-up resistor is needed.

4.3 Pulse Generator

The pulse generator generates pulses when the voltage at the CK1 and CK2 input clock pins changes from Low level to High level (positive-edge trigger) and exceeds the threshold voltage; it sends the clock signal to the watchdog timer.

4.4 Watchdog Timer

The watchdog timer can monitor two clock pulses. Short-circuit the CK1 and CK2 clock pins to monitor a single clock pulse.

4.5 Logic Circuit

Logic circuit controls charging and discharging of the power-on reset hold time setting capacity (C_{TP}) on a signal of Comp.S and Watchdog timer.

5. Absolute Maximum Ratings

Parameter	Symbol	Conditions	Rating		Unit
			Min	Max	
Power supply voltage*	V_{CC}	—	-0.3	+7	V
Input voltage*	CK1	V_{CK1}	-0.3	$V_{CC} + 0.3$ ($\leq +7$)	V
	CK2	V_{CK2}			
	INH	V_{INH}			
Reset output voltage*	\overline{RESET}	V_{OL}	-0.3	$V_{CC} + 0.3$ ($\leq +7$)	V
		V_{OH}			
Reset output current	\overline{RESET}	I_{OL}	-10	+10	mA
		I_{OH}			
Power dissipation	P_D	$T_a \leq +85 \text{ } ^\circ\text{C}$	/	200	mW
Storage temperature	T_{stg}	—	-55	+125	$^\circ\text{C}$

* : The voltage is based on the ground voltage (0 V).

WARNING: Semiconductor devices can be permanently damaged by application of stress (voltage, current, temperature, etc.) in excess of absolute maximum ratings. Do not exceed these ratings.

6. Recommended Operating Conditions

Parameter	Symbol	Conditions	Value			Unit
			Min	Typ	Max	
Power supply voltage	V_{CC}	—	1.2	3.3	4.0	V
Reset (\overline{RESET}) output current	I_{OL}	—	0	—	+ 5	mA
	I_{OH}	—	-5	—	0	
Power-on reset hold time setting capacity	C_{TP}	—	0.001	0.1	10	μF
Watchdog-timer monitoring time setting capacity*	C_{TW}	—	0.001	0.01	1	μF
Operating ambient temperature	T_a	—	-40	+25	+85	$^\circ\text{C}$

* : The watchdog timer monitor time range depends on the rating of the setting capacitor.

WARNING: The recommended operating conditions are required in order to ensure the normal operation of the semiconductor device. All of the device's electrical characteristics are warranted when the device is operated within these ranges. Always use semiconductor devices within their recommended operating condition ranges. Operation outside these ranges may adversely affect reliability and could result in device failure. No warranty is made with respect to uses, operating conditions, or combinations not represented on the data sheet. Users considering application outside the listed conditions are advised to contact their representatives beforehand.

7. Electrical Characteristics

7.1 DC Characteristics

 $(V_{CC} = +3.3\text{ V}, T_a = +25^\circ\text{C})$

Parameter	Symbol	Conditions	Value			Unit	
			Min	Typ	Max		
Power current	ICC1	After exit from reset	—	41	55	μA	
Detection voltage	VSL	VCC falling	Ta = +25°C	2.73	2.80	2.87	V
			Ta = -40 to +85°C	2.69*	2.80	2.91*	
	VSH	VCC rising	Ta = +25°C	2.80	2.87	2.94	V
			Ta = -40 to +85°C	2.76*	2.87	2.98*	
Detection voltage hysteresis difference	VSHYS	VSH - VSL	25	70	100	mV	
CK input threshold voltage	VCIH	—	0.7*	1.3	1.9	V	
	VCIL	—	0.5	1.0	1.5*	V	
CK input hysteresis	VCHYS	—	0.1*	0.3	0.6*	V	
INH input voltage	VIH	—	2.2	—	V _{CC}	V	
	VIL	—	0	—	0.8	V	
Input current (CK1,CK2,INH)	I _{IH}	V _{IH} = V _{CC}	—	0	1.0	μA	
	I _{IL}	V _{IL} = 0 V	-1.0	0	—	μA	
Reset output voltage	VOH	$\overline{\text{RESET}} = -3\text{ mA}$	2.8	3.1	—	V	
	VOL	$\overline{\text{RESET}} = +3\text{ mA}$	—	0.12	0.4	V	
Reset-output minimum power voltage	VCCL	$\overline{\text{RESET}} = +50\text{ }\mu\text{A}$	—	0.8	1.2	V	

* : This parameter is guaranteed by design, which is not supported by a final test.

7.2 AC Characteristics

 $(V_{CC} = +3.3\text{ V}, T_a = +25^\circ\text{C})$

Parameter	Symbol	Conditions	Value			Unit
			Min	Typ	Max	
Power-on reset hold time	tPR	CTP = 0.1 μF	30	75	120	ms
Watchdog timer monitoring time	tWD	CTW = 0.01 μF , CTP = 0.1 μF	8	16	24	ms
Watchdog timer reset time	tWR	CTP = 0.1 μF	2	5.5	9	ms
CK input pulse width	tCKW	—	500	—	—	ns
CK input pulse cycle	tCKT	—	20	—	—	μs
Reset ($\overline{\text{RESET}}$) output transition time	Rising	tr*	—	—	500	ns
	Falling	tf*	—	—	500	ns

*: The voltage range is 10% to 90% at testing the reset output transition time.

8. Timing Diagram

8.1 Basic Operation (Positive Clock Pulse)

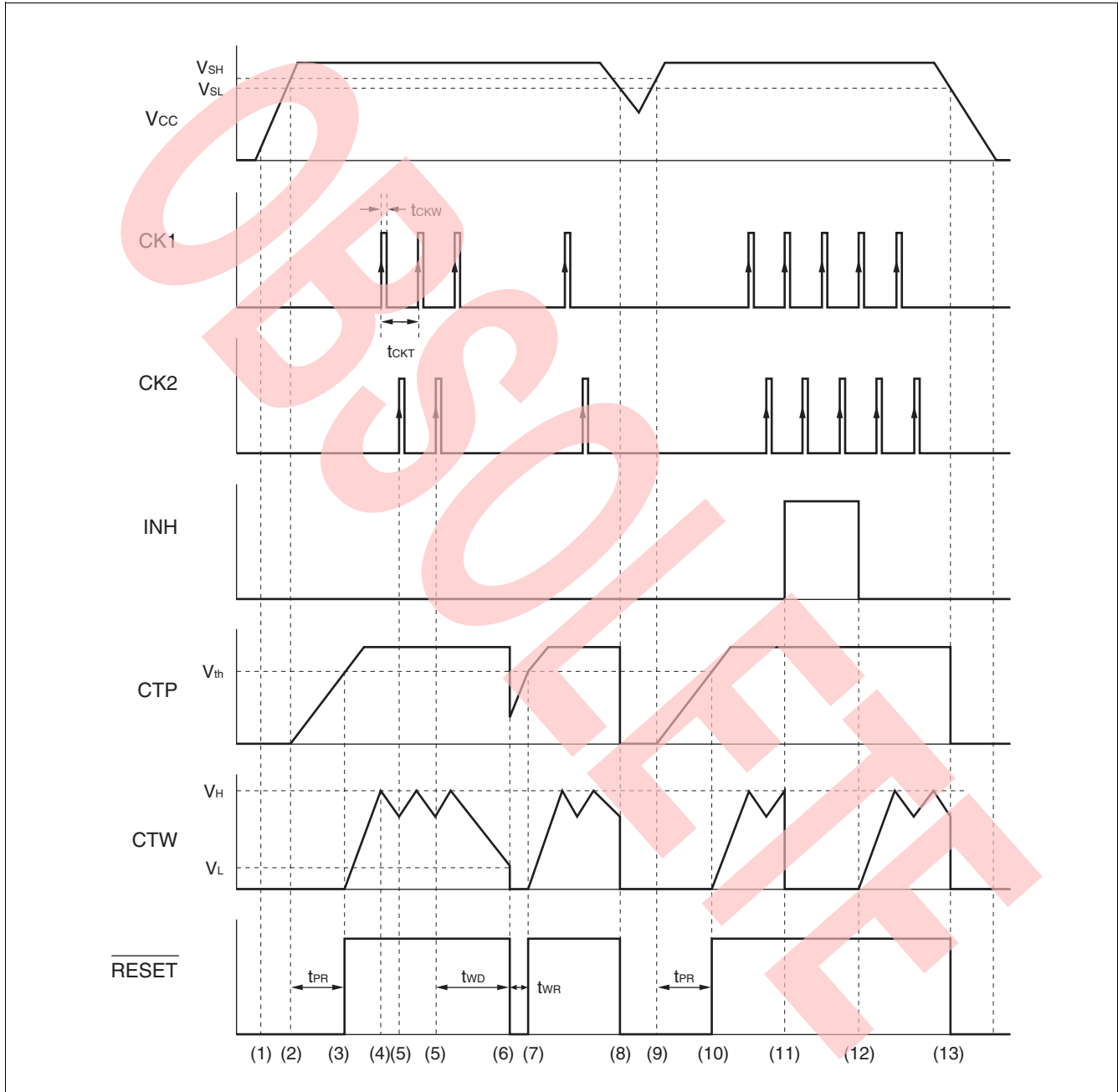

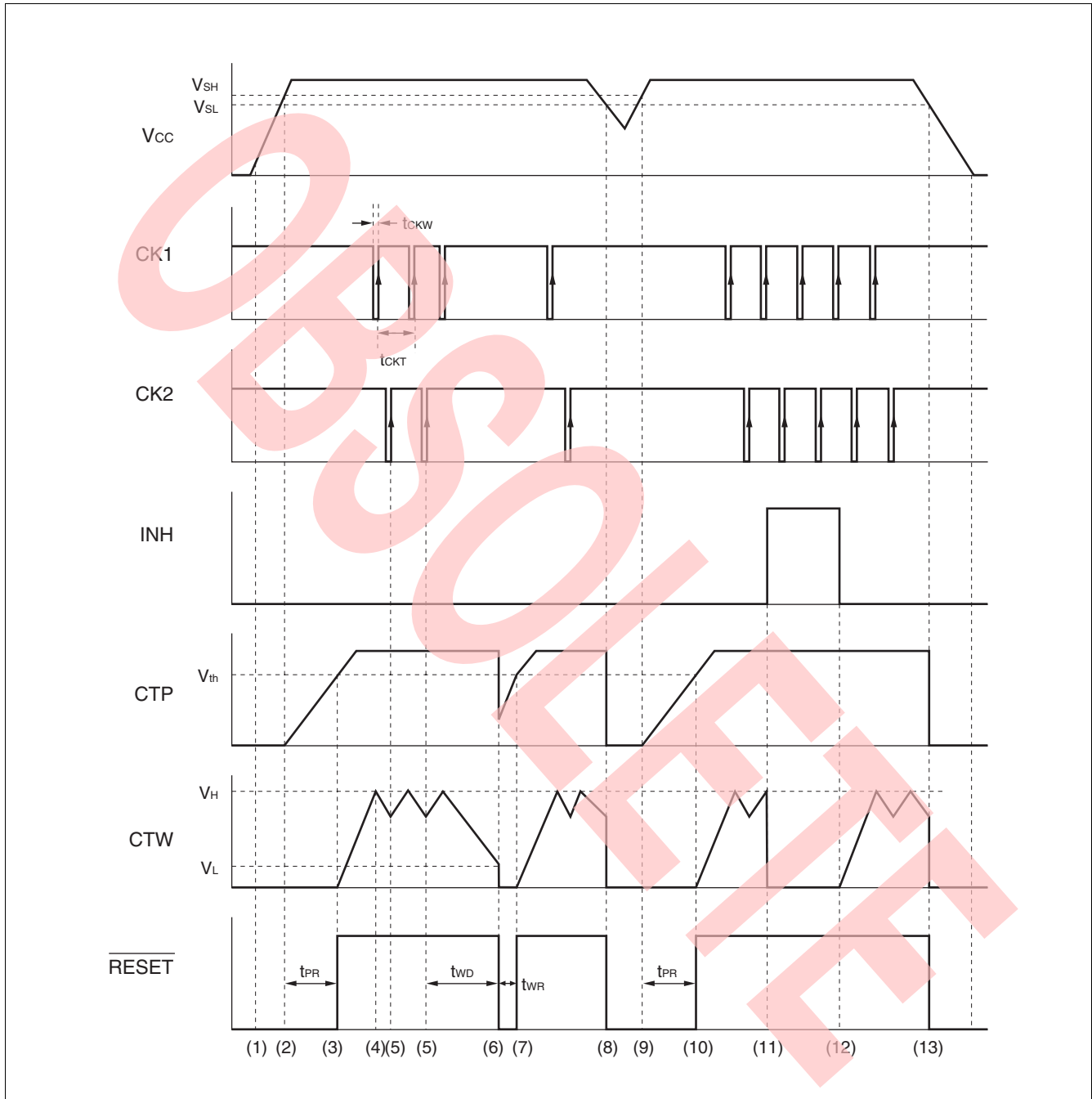
8.2 Basic Operation (Negative Clock Pulse)

8.3 Single-clock Input Monitoring (Positive Clock Pulse)

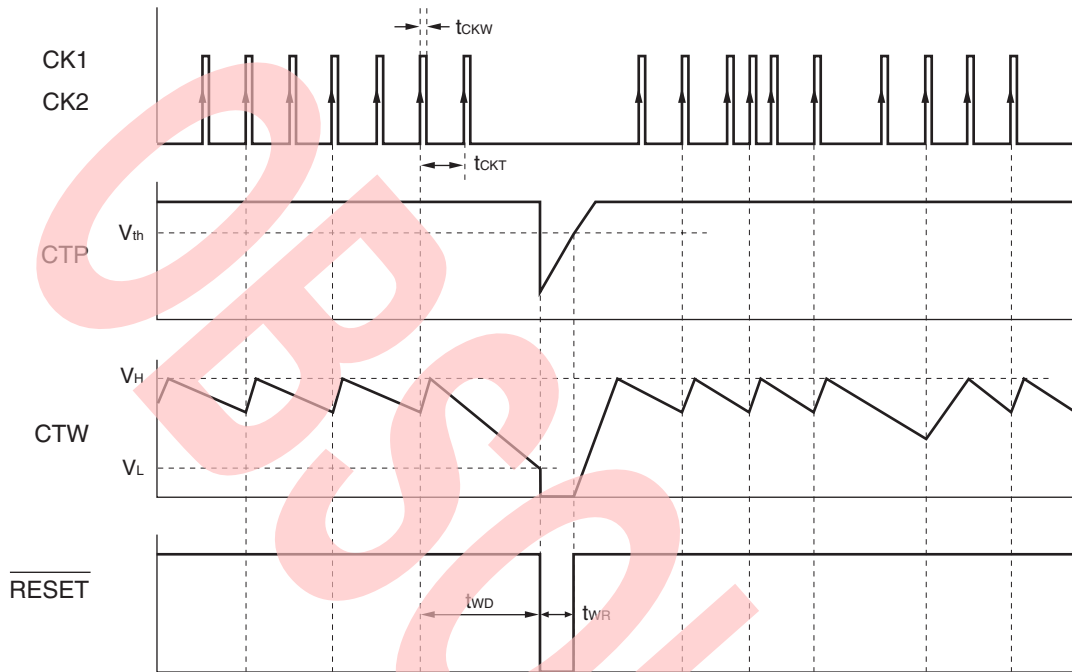

Note : The MB3793 can monitor only one clock.
 The MB3793 checks the clock signal at every other input pulse.
 Therefore, set watchdog timer monitor time t_{WD} to the time that allows the MB3793 to monitor the period twice as long as the input clock pulse.

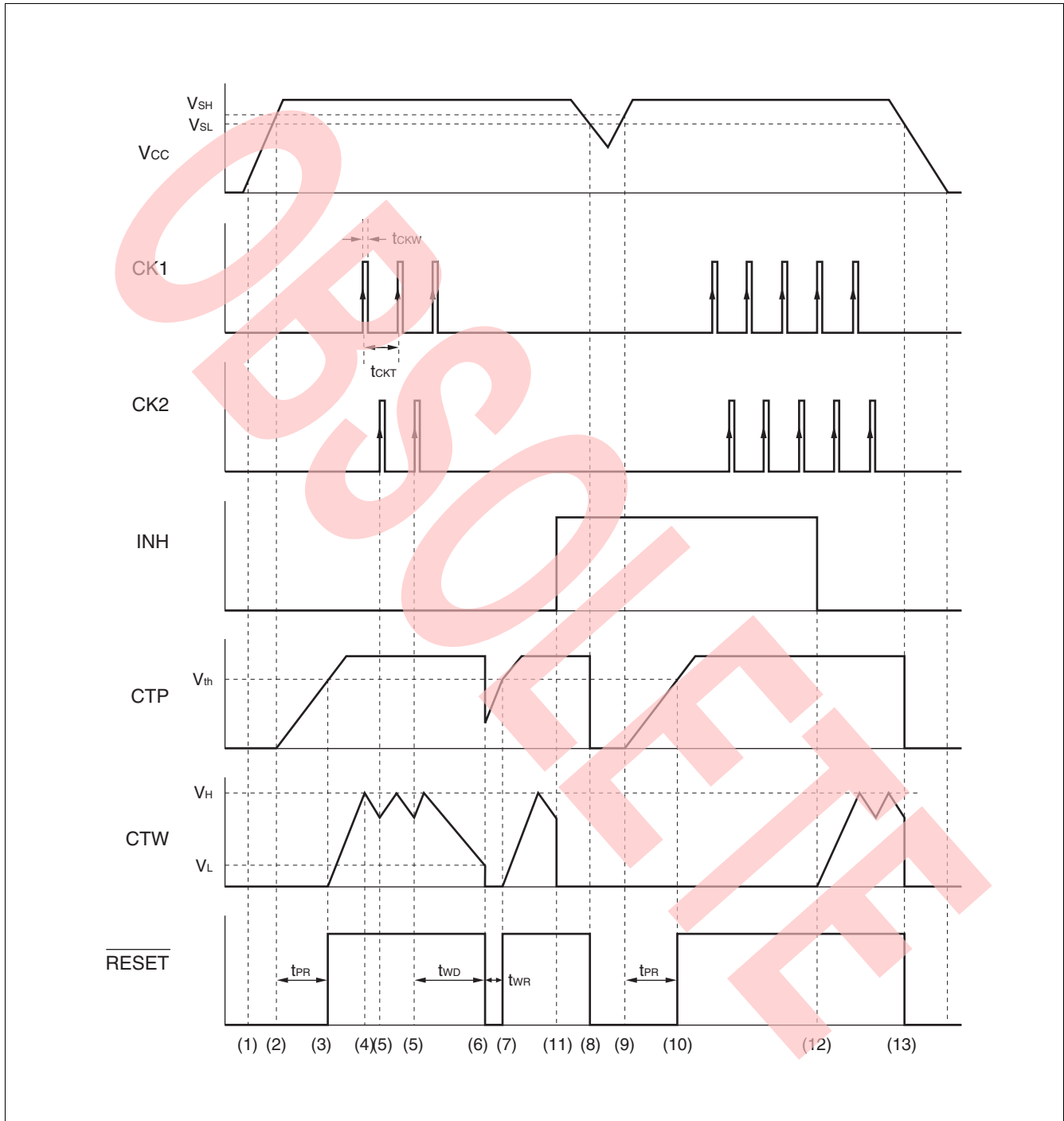
8.4 Inhibition Operation (Positive Clock Pulse)

8.5 Clock Pulse Input Supplementation (Positive Clock Pulse)

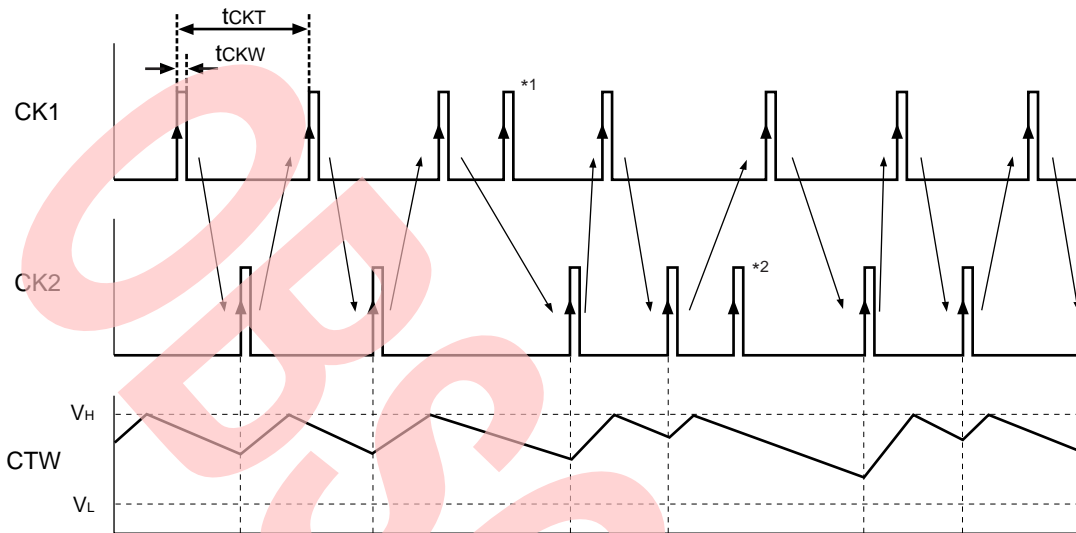

Note : The MB3793 watchdog timer monitors Clock1 (CK1) and Clock2 (CK2) pulses alternately. When a CK2 pulse is detected after detecting a CK1 pulse, the monitoring time setting capacity (C_{TW}) switches to charging from discharging. When two consecutive pulses occur on one side of this alternation before switching, the second pulse is ignored. In the above figure, pulse *1 and *2 are ignored.

9. Operation Sequence

9.1 Positive Clock Pulse Input

Refer to “Basic Operation (Positive Clock Pulse)” under “Timing Diagram”.

9.2 Negative Clock Pulse Input

Refer to “Basic Operation (Negative Clock Pulse)” under “Timing Diagram”.

The MB3793 operates in the same way whether it inputs positive or negative pulses.

9.3 Single-clock Input Monitoring

To use the MB3793 while monitoring only one clock, connect clock pins CK1 and CK2.

Although the MB3793 operates basically in the same way as when monitoring two clocks, it monitors the clock signal at every other input pulse.

Refer to “Single-clock Input Monitoring (Positive Clock Pulse)” under “Timing Diagram”.

9.4 Description of Operations

The numbers given to the following items correspond to numbers (1) to (13) used in “Timing Diagram”.

- (1) The MB3793 outputs a reset signal when the supply voltage (V_{CC}) reaches about 0.8 V (V_{CCL})
- (2) If V_{CC} reaches or exceeds the rise-time detected voltage V_{SH} , the MB3793 starts charging the power-on reset hold time setting capacitor C_{TP} . At this time, the output remains in a reset state. The V_{SH} value is 2.87 V (Typ).
- (3) When C_{TP} has been charged for a certain period of time T_{PR} (until the CTP pin voltage exceeds the threshold voltage (V_{th}) after the start of charging), the MB3793 cancels the reset (setting the \overline{RESET} pin to “H” level from “L” level).
The V_{th} value is about 2.4 V with $V_{CC} = 3.3$ V

The power-on reset hold time t_{PR} is set with the following equation:

$$t_{PR} \text{ (ms)} \approx A \times C_{TP} \text{ (\mu F)}$$

The value of A is about 750 with $V_{CC} = 3.3$ V and about 700 with $V_{CC} = 3.0$ V. The MB3793 also starts charging the watchdog timer monitor time setting capacitor (C_{TW}).

- (4) When the voltage at the watchdog timer monitor time setting pin C_{TW} reaches the “H” level threshold voltage V_H , the C_{TW} switches from the charge state to the discharge state.
The value of V_H is always about 1.24 V regardless of the detected voltage.
- (5) If the CK2 pin inputs a clock pulse (positive edge trigger) when the C_{TW} is being discharged in the CK1-CK2 order or simultaneously, the C_{TW} switches from the discharge state to the charge state.
The MB3793 repeats operations (4) and (5) as long as the CK1/CK2 pin inputs clock pulses with the system logic circuit operating normally.
- (6) If no clock pulse is fed to the CK1 or CK2 pin within the watchdog timer monitor time t_{WD} due to some problem with the system logic circuit, the C_{TW} pin is set to the “L” level threshold voltage V_L or less and the MB3793 outputs a reset signal (setting the \overline{RESET} pin to “L” level from “H” level).
The value of V_L is always about 0.24 V regardless of the detected voltage.
The watchdog timer monitor time t_{WD} is set with the following equation:
$$t_{WD} \text{ (ms)} \approx B \times C_{TW} \text{ (\mu F)} + C \times C_{TP} \text{ (\mu F)}$$

The value of B is hardly affected by the power supply voltage; it is about 1600 with $V_{CC} = 3.0$ V to 3.3 V.
The value of C is 0.
For this reason:
$$t_{WD} \text{ (ms)} \approx B \times C_{TW} \text{ (\mu F)}$$

- (7) When a certain period of time t_{WR} has passed (until the CTP pin voltage reaches or exceeds V_{th} again after recharging the C_{TP}), the MB3793 cancels the reset signal and starts operating the watchdog timer. The watchdog timer monitor reset time t_{WR} is set with the following equation:
 $t_{WR} \text{ (ms)} \approx D \times C_{TP} \text{ (}\mu\text{F)}$
 The value of D is 55 with $V_{CC} = 3.3 \text{ V}$ and about 50 with $V_{CC} = 3.0 \text{ V}$.
 The MB3793 repeats operations (4) and (5) as long as the CK1/CK2 pin inputs clock pulses. If no clock pulse is input, the MB3793 repeats operations (6) and (7).
- (8) If V_{CC} is lowered to the fall-time detected voltage (V_{SL}) or less, the CTP pin voltage decreases and the MB3793 outputs a reset signal (setting the RESET pin to "L" level from "H" level).
 The value of V_{SL} is 2.80 V (Typ).
- (9) When V_{CC} reaches or exceeds V_{SH} again, the MB3793 starts charging the C_{TP} .
- (10) When the CTP pin voltage reaches or exceeds V_{th} , the MB3793 cancels the reset and restarts operating the watchdog timer. It repeats operations (4) and (5) as long as the CK1/CK2 pin inputs clock pulses.
- (11) Making the inhibit pin active (setting the INH pin to "H" from "L") forces the watchdog timer to stop operation.
 This stops only the watchdog timer, leaving the MB3793 monitoring V_{CC} (operations (8) to (10)).
 The watchdog timer remains inactive unless the inhibit input is canceled.
 The inhibition (INH) pin must be connecting a voltage of more low impedance, to evade of the noise.
- (12) Canceling the inhibit input (setting the INH pin to "L" from "H") restarts the watchdog timer.
- (13) The reset signal is output when the power supply is turned off to set V_{CC} to V_{SL} or less.

1. Equation of time-setting capacitances (C_{TP} and C_{TW}) and set time

$$t_{PR} \text{ [ms]} \approx A \times C_{TP} \text{ [}\mu\text{F]}$$

$$t_{WD} \text{ [ms]} \approx B \times C_{TW} \text{ [}\mu\text{F]} + C \times C_{TP} \text{ [}\mu\text{F]}$$

However, when $C_{TP}/C_{TW} \approx 10$ or less, $t_{WD} \text{ [ms]} \approx B \times C_{TW} \text{ [}\mu\text{F]}$

$$t_{WR} \text{ [ms]} \approx D \times C_{TP} \text{ [}\mu\text{F]}$$

Values of A, B, C, and D

A	B	C	D	Remark
750	1600	0	55	$V_{CC} = 3.3 \text{ V}$
700	1600	0	50	$V_{CC} = 3.0 \text{ V}$

Note: The width of value of t_{PR} , t_{WD} and t_{WR} becomes the same ratio as width (Min, Max) of each specification value.

2. Example (when $C_{TP} = 0.1 \mu\text{F}$ and $C_{TW} = 0.01 \mu\text{F}$)

time (ms)	Symbol	$V_{CC} = 3.3 \text{ V}$	$V_{CC} = 3.0 \text{ V}$
	t_{PR}		75
t_{WD}		16	16
t_{WR}		5.5	5

10. Typical Characteristics

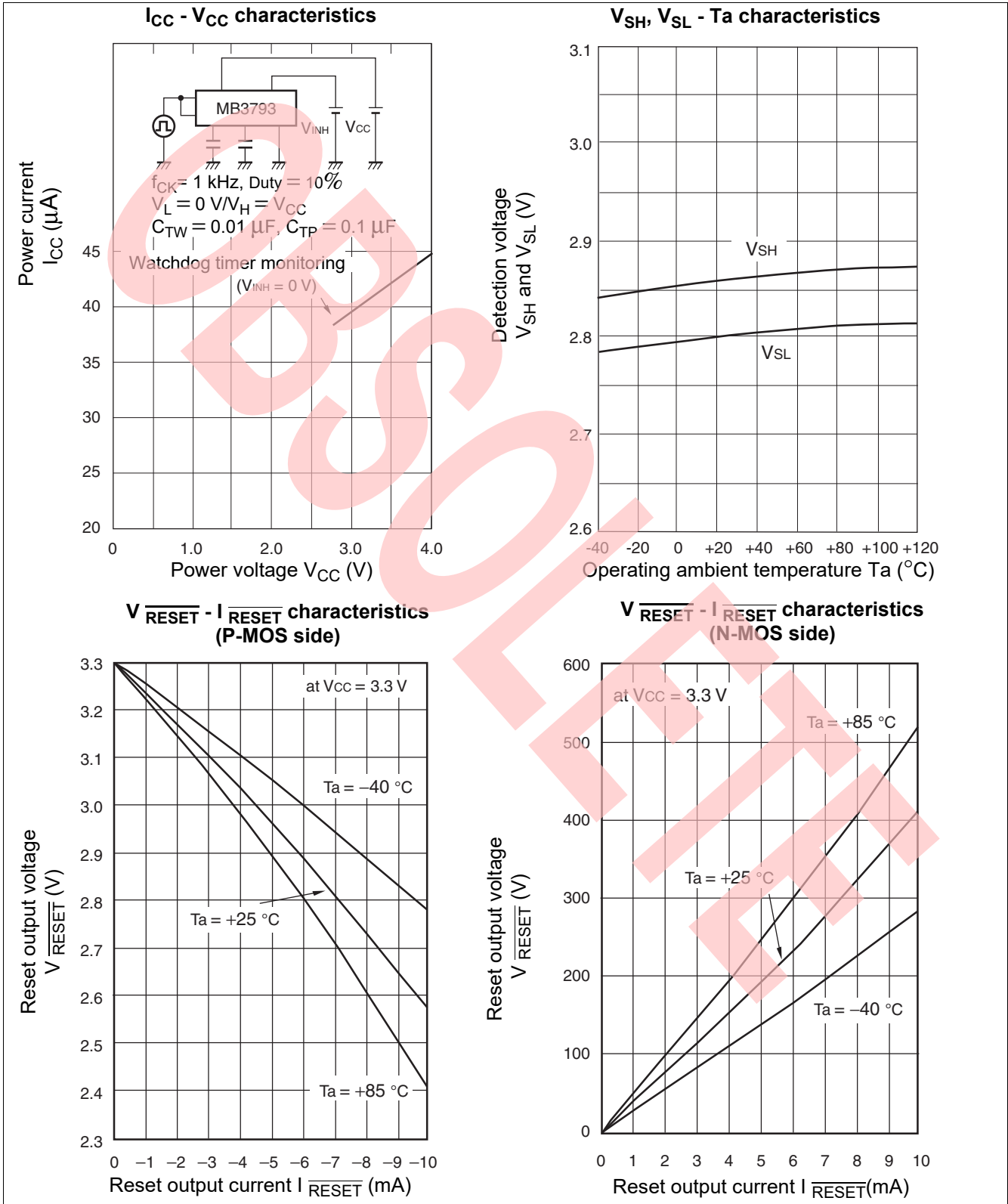

(Continued)

(Continued)

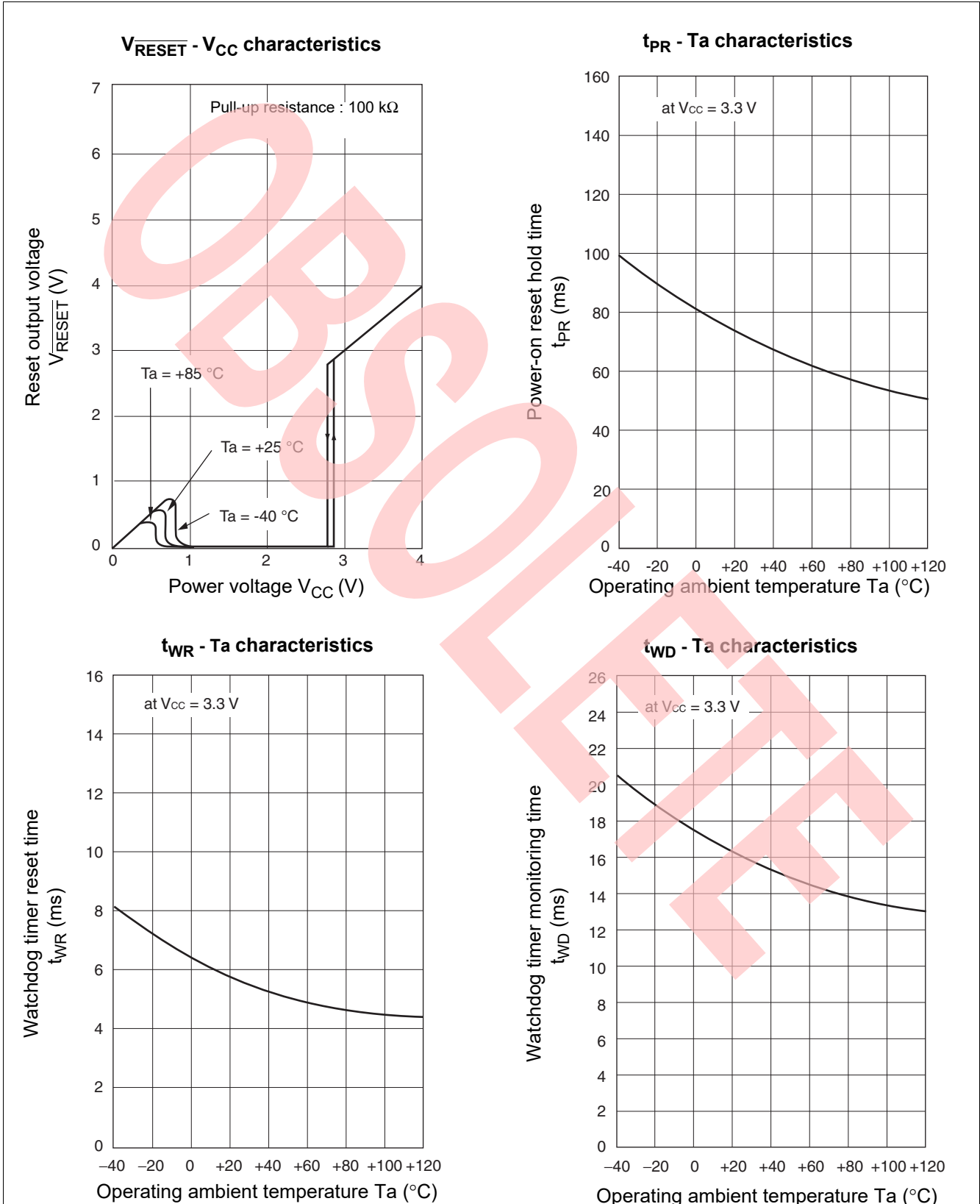

(Continued)

t_{PR} - C_{TP} characteristics

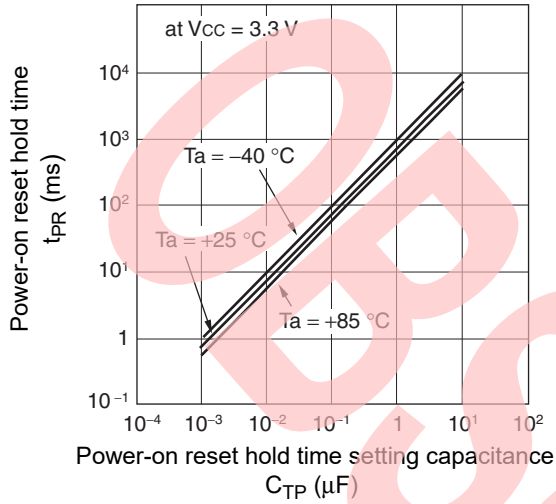

t_{WR} - C_{TP} characteristics

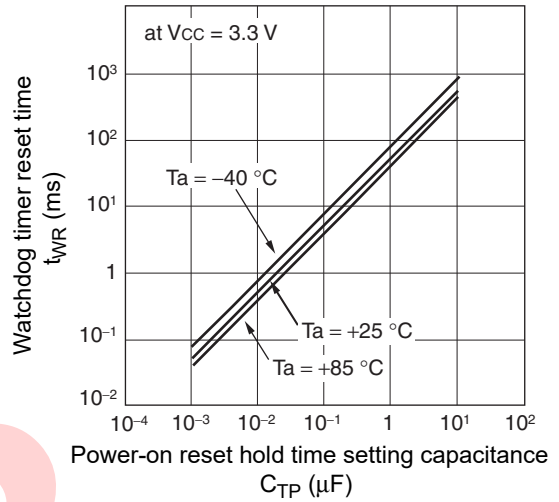

t_{WD} - C_{TW} characteristics

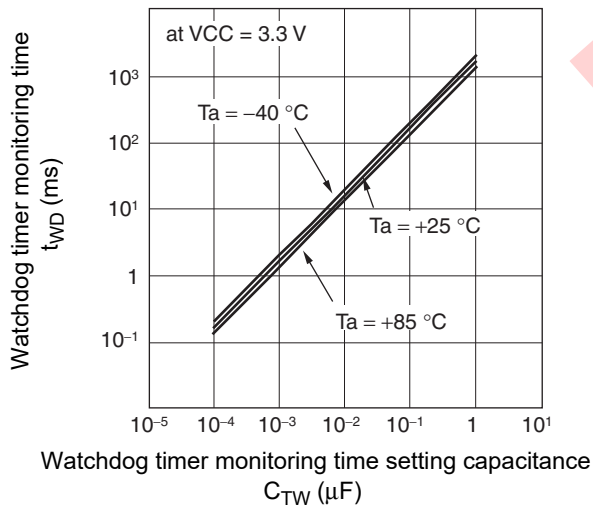

11. Application Example

11.1 Supply Voltage Monitor and Watchdog Timer

11.1.1 1-clock monitor

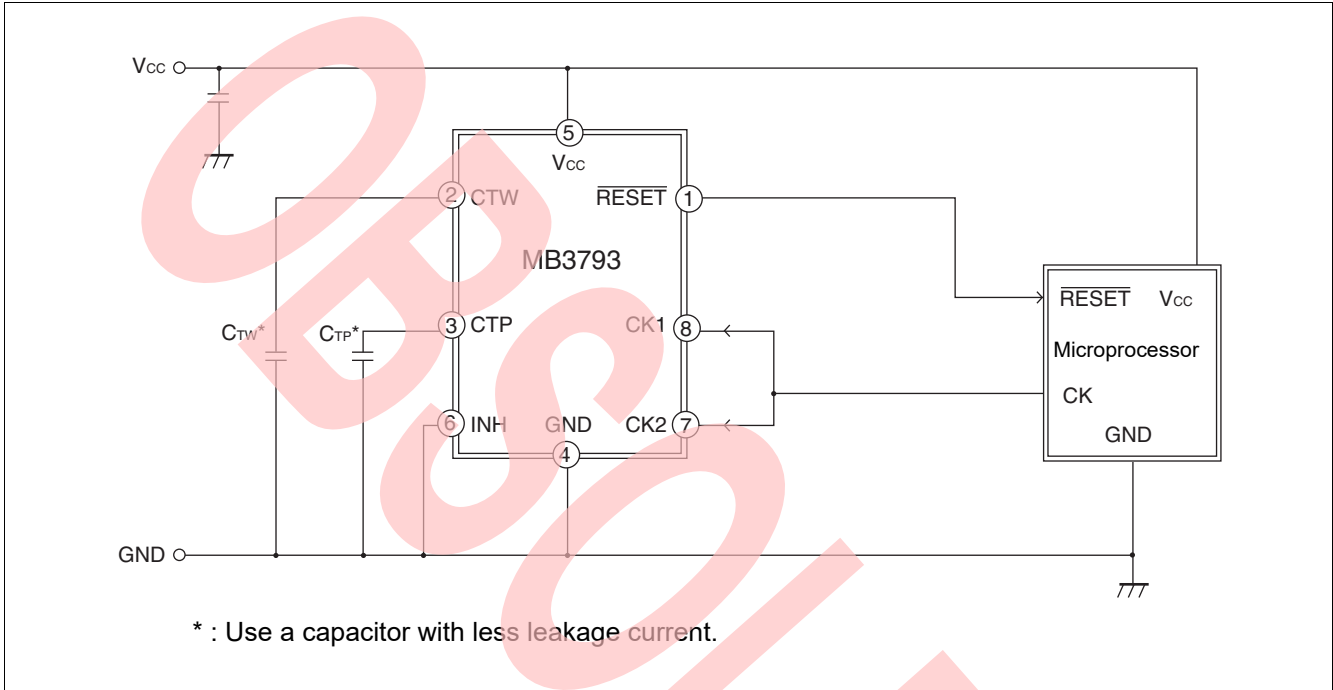

11.1.2 2-clock monitor

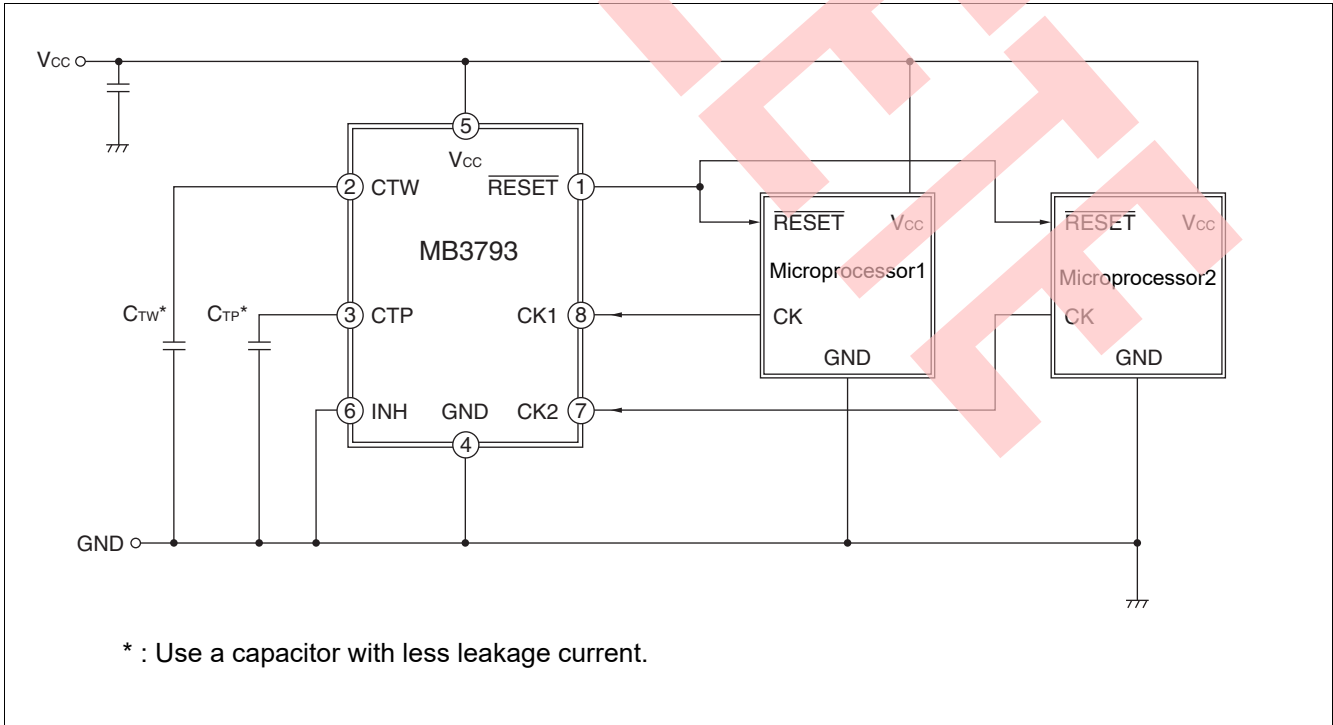

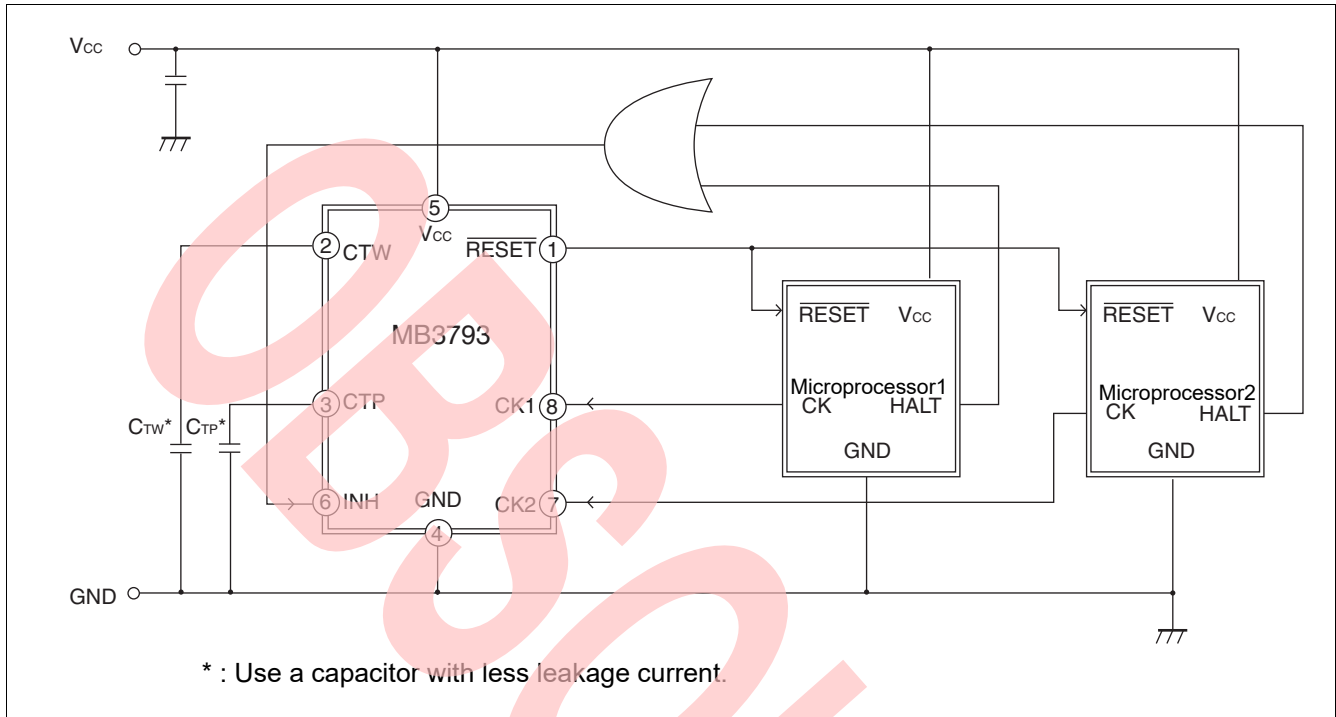
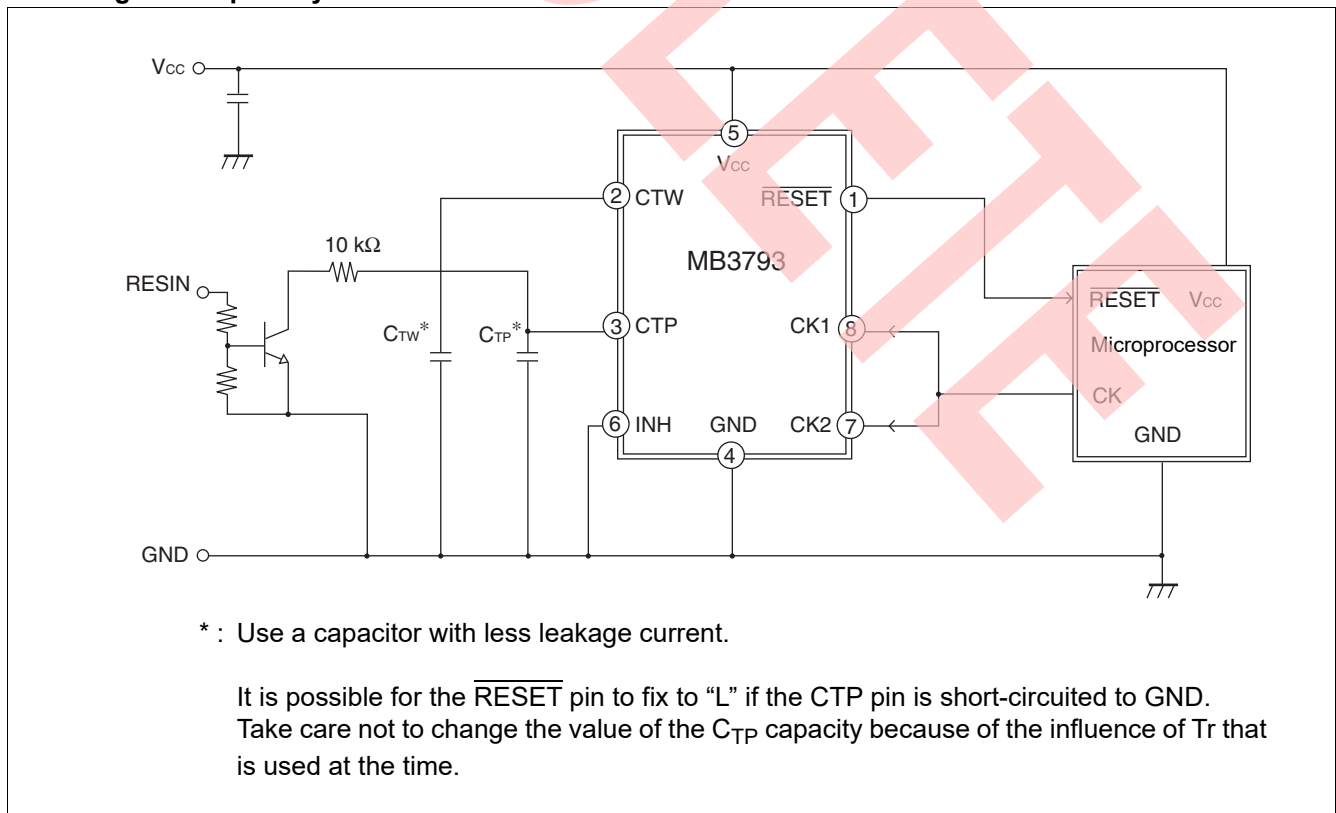
11.2 Supply Voltage Monitor and Watchdog Timer Stop

11.3 Setting of Compulsory Reset

12. Usage Precaution

1. Do not Configure the IC Over the Maximum Ratings

If the IC is used over the maximum ratings, the LSI may be permanently damaged.

It is preferable for the device to normally operate within the recommended usage conditions. Usage outside of these conditions can have a bad effect on the reliability of the LSI.

2. Use the Devices within Recommended Operating Conditions

The recommended operating conditions are under which the LSI is guaranteed to operate.

The electrical ratings are guaranteed when the device is used within the recommended operating conditions and under the conditions stated for each item.

3. Printed Circuit Board Ground Lines Should be Set up with Consideration for Common Impedance

4. Take Appropriate Measures Against Static Electricity

- Containers for semiconductor materials should have anti-static protection or be made of conductive material.
- After mounting, printed circuit boards should be stored and shipped in conductive bags or containers.
- Work platforms, tools, and instruments should be properly grounded.
- Working personnel should be grounded with resistance of 250 kΩ to 1 MΩ between body and ground.

5. Do not Apply Negative Voltages

The use of negative voltages below -0.3 V may create parasitic transistors on LSI lines, which can cause malfunctions.

13. Ordering Information

Part Number	Package	Remarks
MB3793-28APNF	8-pin plastic SOP (SOB008)	-

14. RoHS Compliance Information of Lead (Pb) Free version

The LSI products of Fujitsu Microelectronics with "E1" are compliant with RoHS Directive, and has observed the standard of lead, cadmium, mercury, Hexavalent chromium, polybrominated biphenyls (PBB), and polybrominated diphenyl ethers (PBDE).

The product that conforms to this standard is added "E1" at the end of the part number.

15. Package Dimensions

Package Code: SOB008

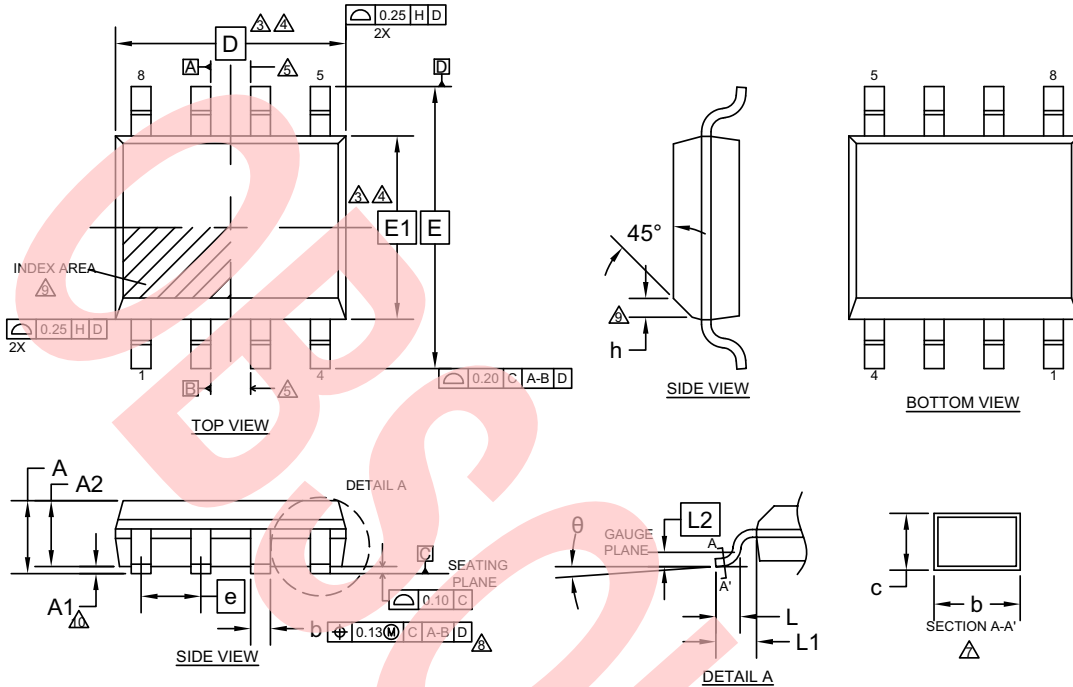

SYMBOL	DIMENSIONS		
	MIN.	NOM.	MAX.
A	—	—	1.75
A1	0.05	—	0.25
A2	1.30	1.40	1.50
D	5.05 BSC.		
E	6.00 BSC.		
E1	3.90 BSC		
θ	0°	—	8°
c	0.15	—	0.25
b	0.36	0.44	0.52
L	0.45	0.60	0.75
L 1	1.05 REF		
L 2	0.25 BSC		
e	1.27 BSC.		
h	0.40 BSC.		

NOTES

- ALL DIMENSIONS ARE IN MILLIMETER.
- DIMENSIONING AND TOLERANCING PER ASME Y14.5M-1994.
- DIMENSIONING D INCLUDE MOLD FLASH, DIMENSIONING E1 DOES NOT INCLUDE INTERLEAD FLASH OR PROTRUSION. INTERLEAD FLASH OR PROTRUSIONS SHALL NOT EXCEED 0.025 mm PER SIDE. D and E1 DIMENSION ARE DETERMINED AT DATUM H.
- THE PACKAGE TOP MAY BE SMALLER THAN THE PACKAGE BOTTOM. DIMENSIONING D and E1 ARE DETERMINED AT THE OUTERMOST EXTREMES OF THE PLASTIC BODY EXCLUSIVE OF MOLD FLASH, THE BAR BURRS, GATE BURRS AND INTERLEAD FLASH, BUT INCLUDING ANY MISMATCH BETWEEN THE TOP AND BOTTOM OF THE PLASTIC BODY.
- DATUMS A & B TO BE DETERMINED AT DATUM H.
- "N" IS THE MAXIMUM NUMBER OF TERMINAL POSITIONS FOR THE SPECIFIED PACKAGE LENGTH.
- THE DIMENSION APPLY TO THE FLAT SECTION OF THE LEAD BETWEEN 0.10 mm TO 0.25mm FROM THE LEAD TIP.
- DIMENSION "b" DOES NOT INCLUDE THE DAMBAR PROTRUSION. ALLOWABLE DAMBAR PROTRUSION SHALL BE 0.10mm TOTAL IN EXCESS OF THE "b" DIMENSION AT MAXIMUM MATERIAL CONDITION. THE DAMBAR MAY NOT BE LOCATED ON THE LOWER RADIUS OF THE FOOT.
- THIS CHAMFER FEATURE IS OPTIONAL. IF IT IS NOT PRESENT, THEN A PIN 1 IDENTIFIER MUST BE LOCATED WITHIN THE INDEX AREA INDICATED
- "A1" IS DEFINED AS THE VERTICAL DISTANCE FROM THE SEATING PLANE TO THE LOWEST POINT ON THE PACKAGE BODY EXCLUDING THE LID AND OR THERMAL ENHANCEMENT ON CAVITY DOWN PACKAGE CONFIGURATIONS.
- JEDEC SPECIFICATION NO. REF : N/A

002-15856 Rev. **

16. Document History

Document Title: MB3793-28A Power-Voltage Monitoring IC with Watchdog Timer Datasheet Document Number: 002-08559				
Revision	ECN	Orig. of Change	Submission Date	Description of Change
**	—	TAOA	12/03/2009	Migrated to Cypress and assigned document number 002-08559. No change to document contents or format.
*A	5186892	TAOA	03/31/2016	Updated to Cypress template
*B	5606220	HIXT	02/07/2017	Updated Pin Assignment : Change the package name from FPT-8P-M01 to SOE008 Updated Ordering Information : Change the package name from FPT-8P-M01 to SOE008 Updated Package Dimensions : Updated to Cypress format Deleted "Marking Format (Lead Free version)" Deleted "Labeling Sample (Lead free version)" Deleted "MB3793-28APNF Recommended Conditions of Moisture Sensitivity Level"
*C	5782377	MASG	06/22/2017	Adapted Cypress new logo.
*D	6459753	SSAS	01/25/2019	Obsoleted.

Sales, Solutions, and Legal Information

Worldwide Sales and Design Support

Cypress maintains a worldwide network of offices, solution centers, manufacturer's representatives, and distributors. To find the office closest to you, visit us at [Cypress Locations](#).

Products

ARM [®] Cortex [®] Microcontrollers	cypress.com/arm
Automotive	cypress.com/automotive
Clocks & Buffers	cypress.com/clocks
Interface	cypress.com/interface
Internet of Things	cypress.com/iot
Memory	cypress.com/memory
Microcontrollers	cypress.com/mcu
PSoC	cypress.com/psoc
Power Management ICs	cypress.com/pmic
Touch Sensing	cypress.com/touch
USB Controllers	cypress.com/usb
Wireless/Rf	cypress.com/wireless

PSoC[®] Solutions

[PSoC 1](#) | [PSoC 3](#) | [PSoC 4](#) | [PSoC 5LP](#) | [PSoC 6](#)

Cypress Developer Community

[Forums](#) | [WICED IOT Forums](#) | [Projects](#) | [Video](#) | [Blogs](#) | [Training](#) | [Components](#)

Technical Support

cypress.com/support

© Cypress Semiconductor Corporation, 2009-2019. This document is the property of Cypress Semiconductor Corporation and its subsidiaries, including Spansion LLC ("Cypress"). This document, including any software or firmware included or referenced in this document ("Software"), is owned by Cypress under the intellectual property laws and treaties of the United States and other countries worldwide. Cypress reserves all rights under such laws and treaties and does not, except as specifically stated in this paragraph, grant any license under its patents, copyrights, trademarks, or other intellectual property rights. If the Software is not accompanied by a license agreement and you do not otherwise have a written agreement with Cypress governing the use of the Software, then Cypress hereby grants you a personal, non-exclusive, nontransferable license (without the right to sublicense) (1) under its copyright rights in the Software (a) for Software provided in source code form, to modify and reproduce the Software solely for use with Cypress hardware products, only internally within your organization, and (b) to distribute the Software in binary code form externally to end users (either directly or indirectly through resellers and distributors), solely for use on Cypress hardware product units, and (2) under those claims of Cypress's patents that are infringed by the Software (as provided by Cypress, unmodified) to make, use, distribute, and import the Software solely for use with Cypress hardware products. Any other use, reproduction, modification, translation, or compilation of the Software is prohibited.

TO THE EXTENT PERMITTED BY APPLICABLE LAW, CYPRESS MAKES NO WARRANTY OF ANY KIND, EXPRESS OR IMPLIED, WITH REGARD TO THIS DOCUMENT OR ANY SOFTWARE OR ACCOMPANYING HARDWARE, INCLUDING, BUT NOT LIMITED TO, THE IMPLIED WARRANTIES OF MERCHANTABILITY AND FITNESS FOR A PARTICULAR PURPOSE. No computing device can be absolutely secure. Therefore, despite security measures implemented in Cypress hardware or software products, Cypress does not assume any liability arising out of any security breach, such as unauthorized access to or use of a Cypress product. In addition, the products described in these materials may contain design defects or errors known as errata which may cause the product to deviate from published specifications. To the extent permitted by applicable law, Cypress reserves the right to make changes to this document without further notice. Cypress does not assume any liability arising out of the application or use of any product or circuit described in this document. Any information provided in this document, including any sample design information or programming code, is provided only for reference purposes. It is the responsibility of the user of this document to properly design, program, and test the functionality and safety of any application made of this information and any resulting product. Cypress products are not designed, intended, or authorized for use as critical components in systems designed or intended for the operation of weapons, weapons systems, nuclear installations, life-support devices or systems, other medical devices or systems (including resuscitation equipment and surgical implants), pollution control or hazardous substances management, or other uses where the failure of the device or system could cause personal injury, death, or property damage ("Unintended Uses"). A critical component is any component of a device or system whose failure to perform can be reasonably expected to cause the failure of the device or system, or to affect its safety or effectiveness. Cypress is not liable, in whole or in part, and you shall and hereby do release Cypress from any claim, damage, or other liability arising from or related to all Unintended Uses of Cypress products. You shall indemnify and hold Cypress harmless from and against all claims, costs, damages, and other liabilities, including claims for personal injury or death, arising from or related to any Unintended Uses of Cypress products.

Cypress, the Cypress logo, Spansion, the Spansion logo, and combinations thereof, WICED, PSoC, CapSense, EZ-USB, F-RAM, and Traveo are trademarks or registered trademarks of Cypress in the United States and other countries. For a more complete list of Cypress trademarks, visit cypress.com. Other names and brands may be claimed as property of their respective owners.

Looking for pricing, stock, or lifecycle information?

Click below to explore more details on WIN SOURCE:

- ⊖ [View MB3793-28APNF-G-JN-EF6E1 on WIN SOURCE](#)
- ⊖ [Fujitsu Electronics America, Inc. Information](#)

Optimize Your Supply Chain with WIN SOURCE Solutions

- ✓ Global Sourcing Solution
- ✓ Obsolete Management
- ✓ Cost Control Management
- ✓ Shortage Management
- ✓ Alternative Solution
- ✓ Excess Inventory Management