



**THE DATASHEET OF
MAX9248ECM+T**



MAX9248/MAX9250

27-Bit, 5MHz to 42MHz DC-Balanced LVDS Deserializers

General Description

The MAX9248/MAX9250 digital video serial-to-parallel converters deserialize a total of 27 bits during data and control phases. In the data phase, the LVDS serial input is converted to 18 bits of parallel video data and in the control phase, the input is converted to 9 bits of parallel control data. The separate video and control phases take advantage of video timing to reduce the serial-data rate. The MAX9248/MAX9250 pair with the MAX9247 serializer to form a complete digital video transmission system. For operating frequencies less than 35MHz, the MAX9248/MAX9250 can also pair with the MAX9217 serializer.

The MAX9248 features spread-spectrum capability, allowing output data and clock to spread over a specified frequency range to reduce EMI. The data and clock outputs are programmable for a spectrum spread of $\pm 4\%$ or $\pm 2\%$. The MAX9250 features output enable input control to allow data busing.

Proprietary data decoding reduces EMI and provides DC balance. The DC balance allows AC-coupling, providing isolation between the transmitting and receiving ends of the interface. The MAX9248/MAX9250 feature a selectable rising or falling output latch edge.

ESD tolerance is specified for ISO 10605 with $\pm 10\text{kV}$ Contact Discharge and $\pm 30\text{kV}$ Air-Gap Discharge.

The MAX9248/MAX9250 operate from a $+3.3\text{V} \pm 10\%$ core supply and feature a separate output supply for interfacing to 1.8V to 3.3V logic-level inputs. These devices are available in a 48-lead LQFP package and are specified from -40°C to $+85^\circ\text{C}$ or -40°C to $+105^\circ\text{C}$.

Applications

- Navigation System Displays
- In-Vehicle Entertainment Systems
- Video Cameras
- LCD Displays

Benefits and Features

- Programmable $\pm 4\%$ or $\pm 2\%$ Spread-Spectrum Output for Reduced EMI (MAX9248)
- Proprietary Data Decoding for DC Balance and Reduced EMI
- Control Data Deserialized During Video Blanking
- Five Control Data Inputs are Single-Bit-Error Tolerant
- Output Transition Time is Scaled to Operating Frequency for Reduced EMI
- Staggered Output Switching Reduces EMI
- Output Enable Allows Busing of Outputs (MAX9250)
- Clock Pulse Stretch on Lock
- Wide $\pm 2\%$ Reference Clock Tolerance
- Synchronizes to MAX9247 Serializer Without External Control
- ISO 10605 and IEC 61000-4-2 Level 4 ESD Protection
- Separate Output Supply Allows Interface to 1.8V to 3.3V Logic
- $+3.3\text{V}$ Core Power Supply
- Space-Saving LQFP Package
- -40°C to $+85^\circ\text{C}$ and -40°C to $+105^\circ\text{C}$ Operating Temperature Ranges

Ordering Information appears at end of data sheet.



Absolute Maximum Ratings

V_{CC_} to _GND.....-0.5V to +4.0V
 Any Ground to Any Ground.....-0.5V to +0.5V
 IN+, IN- to LVDSGND.....-0.5V to +4.0V
 IN+, IN- Short Circuit to LVDSGND or V_{CCLVDS}.....Continuous
 (R/F, OUTEN, RNG_, REFCLK, SS
 PWRDWN) to GND-0.5V to (V_{CC} + 0.5V)
 (RGB_OUT[17:0], CNTL_OUT[8:0], DE_OUT, PCLK_OUT,
 LOCK) to V_{CCOGND}.....-0.5V to (V_{CCO} + 0.5V)
 Continuous Power Dissipation (T_A = +70°C)
 48-Lead LQFP (derate 21.7mW/°C above +70°C)....1739mW

ESD Protection
 Machine Model (R_D = 0Ω, C_S = 200pF)
 All Pins to GND.....±200V
 Human Body Model (R_D = 1.5kΩ, C_S = 100pF)
 All Pins to GND.....±2kV
 ISO 10605 (R_D = 2kΩ, C_S = 330pF)
 Contact Discharge (IN+, IN-) to GND.....±10kV
 Air-Gap Discharge (IN+, IN-) to GND.....±30kV
 IEC 61000-4-2 (R_D = 330Ω, C_S = 150pF)
 Contact Discharge (IN+, IN-) to GND.....±10kV
 Air-Gap Discharge (IN+, IN-) to GND.....±15kV
 Storage Temperature Range.....-65°C to +150°C
 Junction Temperature.....+150°C
 Lead Temperature (soldering, 10s).....+300°C

Stresses beyond those listed under "Absolute Maximum Ratings" may cause permanent damage to the device. These are stress ratings only, and functional operation of the device at these or any other conditions beyond those indicated in the operational sections of the specifications is not implied. Exposure to absolute maximum rating conditions for extended periods may affect device reliability.

DC Electrical Characteristics

(V_{CC_} = +3.0V to +3.6V, PWRDWN = high, differential input voltage |V_{ID}| = 0.05V to 1.2V, input common-mode voltage V_{CM} = |V_{ID}/2| to V_{CC} - |V_{ID}/2|, T_A = -40°C to +105°C, unless otherwise noted. Typical values are at V_{CC_} = +3.3V, |V_{ID}| = 0.2V, V_{CM} = 1.2V, T_A = +25°C.) (Notes 1, 2)

PARAMETER	SYMBOL	CONDITIONS		MIN	TYP	MAX	UNITS
SINGLE-ENDED INPUTS (R/F, OUTEN, RNG0, RNG1, REFCLK, PWRDWN, SS)							
High-Level Input Voltage	V _{IH}			2.0	V _{CC} + 0.3		V
Low-Level Input Voltage	V _{IL}			-0.3		+0.8	V
Input Current	I _{IN}	PWRDWN = high or low	V _{IN} = -0.3V to 0 (MAX9248/MAX9250ECM), V _{IN} = -0.15V to 0 (MAX9248/MAX9250GCM),	-100		+20	μA
			V _{IN} = 0 to (V _{CC} + 0.3V)	-20		+20	
Input Clamp Voltage	V _{CL}	I _{CL} = -18mA				-1.5	V
SINGLE-ENDED OUTPUTS (RGB_OUT[17:0], CNTL_OUT[8:0], DE_OUT, PCLK_OUT, LOCK)							
High-Level Output Voltage	V _{OH}	I _{OH} = -100μA		V _{CCO} - 0.1		V	
		I _{OH} = -2mA, RNG1 = high		V _{CCO} - 0.35			
		I _{OH} = -2mA, RNG1 = low		V _{CCO} - 0.4			
Low-Level Output Voltage	V _{OL}	I _{OL} = 100μA		0.1		V	
		I _{OL} = 2mA, RNG1 = high		0.3			
		I _{OL} = 2mA, RNG1 = low		0.35			
High-Impedance Output Current	I _{OZ}	PWRDWN = low or OUTEN = low, V _O = -0.3V to (V _{CCO} + 0.3V)		-10		+10	μA
Output Short-Circuit Current	I _{OS}	RNG1 = high, V _O = 0		-10		-50	mA
		RNG1 = low, V _O = 0		-7		-40	

Electrical Characteristics (continued)

($V_{CC_}$ = +3.0V to +3.6V, \overline{PWRDWN} = high, differential input voltage $|V_{ID}|$ = 0.05V to 1.2V, input common-mode voltage $V_{CM} = |V_{ID}/2|$ to $V_{CC_} - |V_{ID}/2|$, $T_A = -40^\circ\text{C}$ to $+105^\circ\text{C}$, unless otherwise noted. Typical values are at $V_{CC_} = +3.3\text{V}$, $|V_{ID}| = 0.2\text{V}$, $V_{CM} = 1.2\text{V}$, $T_A = +25^\circ\text{C}$.) (Notes 1, 2)

PARAMETER	SYMBOL	CONDITIONS		MIN	TYP	MAX	UNITS
LVDS INPUT (IN+, IN-)							
Differential Input High Threshold	V_{TH}	(Note 3)				50	mV
Differential Input Low Threshold	V_{TL}	(Note 3)		-50			mV
Input Current	I_{IN+}, I_{IN-}	\overline{PWRDWN} = high or low (Note 3)		-40		+40	μA
Input Bias Resistor (Note 3)	R_{IB}	\overline{PWRDWN} = high or low	MAX9248/MAX9250ECM	42	60	78	k Ω
			MAX9248/MAX9250GCM	42	60	88	
		$V_{CC_} = 0$ or open, $\overline{PWRDWN} = 0$ or open, Figure 1	MAX9248/MAX9250ECM	42	60	78	
			MAX9248/MAX9250GCM	42	60	88	
Power-Off Input Current	I_{INO+}, I_{INO-}	$V_{CC_} = 0$ or open, $\overline{PWRDWN} = 0$ or open (Note 3)		-60		+60	μA
POWER SUPPLY							
Worst-Case Supply Current		MAX9250 $C_L = 8\text{pF}$, worst-case pattern, Figure 2	RNG1 = low RNG0 = high	5MHz		28	
				10MHz		49	
			RNG1 = high RNG0 = low	10MHz		33	
				20MHz		59	
			RNG1 = high RNG0 = high	20MHz		45	
				42MHz		89	
		MAX9248 $C_L = 8\text{pF}$, worst-case pattern, Figure 2	RNG1 = low RNG0 = high	5MHz		40	
				10MHz		70	
			RNG1 = high RNG0 = low	10MHz		49	
				20MHz		87	
			RNG1 = high RNG0 = high	20MHz		68	
				35MHz		100	
42MHz		120					
Power-Down Supply Current	I_{CCZ}	(Note 4)				50	μA

AC Electrical Characteristics

(V_{CC-} = +3.0V to +3.6V, C_L = 8pF, PWRDWN = high, differential input voltage |V_{ID}| = 0.1V to 1.2V, input common-mode voltage V_{CM} = |V_{ID}/2| to V_{CC-} - |V_{ID}/2|, T_A = -40°C to +105°C, unless otherwise noted. Typical values are at V_{CC-} = +3.3V, |V_{ID}| = 0.2V, V_{CM} = 1.2V, T_A = +25°C.) (Notes 3, 5)

PARAMETER	SYMBOL	CONDITIONS		MIN	TYP	MAX	UNITS	
REFCLK TIMING REQUIREMENTS								
Period	t _t	MAX9248/MAX9250ECM		23.8		200	ns	
		MAX9248/MAX9250GCM		28.6		200		
Frequency	f _{CLK}	MAX9248/MAX9250ECM		5		42.0	MHz	
		MAX9248/MAX9250GCM		5		35.0		
Frequency Variation	Δf _{CLK}	REFCLK to serializer PCLK_IN, worst-case output pattern (Figure 2)		-2.0		+2.0	%	
Duty Cycle	DC			40	50	60	%	
Transition Time	t _{TRAN}	20% to 80%				6	ns	
SWITCHING CHARACTERISTICS								
Output Rise Time	t _R	Figure 3	RNG1 = high	MAX9248/MAX9250ECM	2.2		4.6	ns
				MAX9248/MAX9250GCM	2.2		4.9	
			RNG1 = low	MAX9248/MAX9250ECM	2.8		5.2	
				MAX9248/MAX9250GCM	2.8		6.1	
Output Fall Time	t _R	Figure 3	RNG1 = high	MAX9248/MAX9250ECM	1.9		4.0	ns
			RNG1 = low	MAX9248/MAX9250ECM	2.3		4.3	
				MAX9248/MAX9250GCM	2.3		5.2	
PCLK_OUT High Time	t _{HIGH}	Figure 4		0.4 x t _T	0.45 x t _T	0.6 x t _T	ns	
PCLK_OUT Low Time	t _{LOW}	Figure 4		0.4 x t _T	0.45 x t _T	0.6 x t _T	ns	
Data Valid Before PCLK_OUT	t _{DVB}	Figure 5		0.35 x t _T	0.4 x t _T		ns	
Data Valid After PCLK_OUT	t _{DVA}	Figure 5		0.35 x t _T	0.4 x t _T		ns	
PLL Lock to REFCLK	t _{PLLREF}	MAX9248, Figure 8				33,600 x t _T	ns	
		MAX9250, Figure 7				16,928 x t _T		

AC Electrical Characteristics (continued)

($V_{CC-} = +3.0V$ to $+3.6V$, $C_L = 8pF$, $\overline{PWRDWN} = \text{high}$, differential input voltage $|V_{ID}| = 0.1V$ to $1.2V$, input common-mode voltage $V_{CM} = |V_{ID}/2|$ to $V_{CC-} - |V_{ID}/2|$, $T_A = -40^\circ C$ to $+105^\circ C$, unless otherwise noted. Typical values are at $V_{CC-} = +3.3V$, $|V_{ID}| = 0.2V$, $V_{CM} = 1.2V$, $T_A = +25^\circ C$.) (Notes 3, 5)

PARAMETER	SYMBOL	CONDITIONS		MIN	TYP	MAX	UNITS
Spread-Spectrum Output Frequency (MAX9248)	f_{PCLK_OUT}	SS = high, Figure 11	Maximum output frequency	$f_{REFCLK} + 3.6\%$	$f_{REFCLK} + 4.0\%$	$f_{REFCLK} + 4.4\%$	MHz
			Minimum output frequency	$f_{REFCLK} - 4.4\%$	$f_{REFCLK} - 4.0\%$	$f_{REFCLK} - 3.6\%$	
		SS = low, Figure 11	Maximum output frequency	$f_{REFCLK} + 1.8\%$	$f_{REFCLK} + 2.0\%$	$f_{REFCLK} + 2.2\%$	
			Minimum output frequency	$f_{REFCLK} - 2.2\%$	$f_{REFCLK} - 2.0\%$	$f_{REFCLK} - 1.8\%$	
Spread-Spectrum Modulation Frequency	f_{SSM}	Figure 11		$f_{REFCLK} + 3.6\%$		kHz	
Power-Down Delay	t_{PDD}	Figures 7, 8		100		ns	
SS Change Delay	$t_{\Delta SSPLL}$	MAX9248, Figure 17		$32,800 \times t_T$		ns	
Output Enable Time	t_{OE}	MAX9250, Figure 8		10	30	ns	
Output Disable Time	t_{OZ}	MAX9250, Figure 9		10	30	ns	

Note 1: Current into a pin is defined as positive. Current out of a pin is defined as negative. All voltages are referenced to ground except V_{TH} and V_{TL} .

Note 2: Maximum and minimum limits over temperature are guaranteed by design and characterization. Devices are production tested at $T_A = +25^\circ C$.

Note 3: Parameters are guaranteed by design and characterization, and are not production tested. Limits are set at ± 6 sigma.

Note 4: All LVTTTL/LVCMOS inputs, except \overline{PWRDWN} at $\leq 0.3V$ or $\geq V_{CC-} - 0.3V$. \overline{PWRDWN} is $\leq 0.3V$, REFCLK is static.

Note 5: C_L includes probe and test jig capacitance.

Typical Operating Characteristics

($V_{CC_} = +3.3V$, $C_L = 8pF$, $T_A = +25^\circ C$, unless otherwise noted.)

WORST-CASE PATTERN SUPPLY CURRENT vs. FREQUENCY

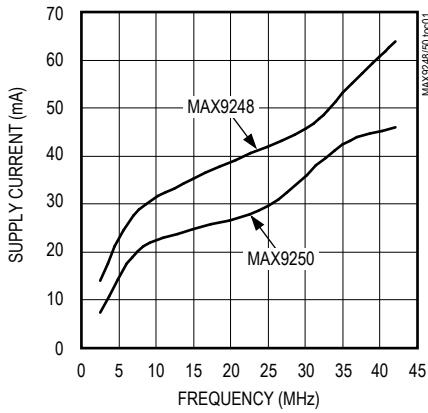

OUTPUT TRANSITION TIME vs. OUTPUT SUPPLY VOLTAGE (V_{CCO})

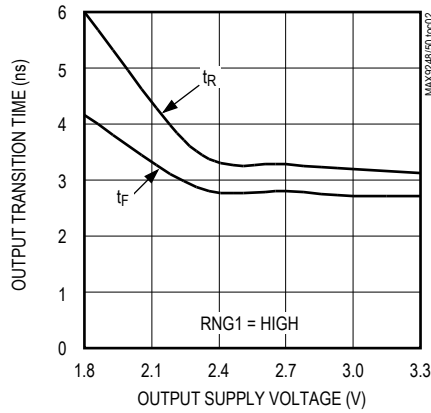

OUTPUT TRANSITION TIME vs. OUTPUT SUPPLY VOLTAGE (V_{CCO})

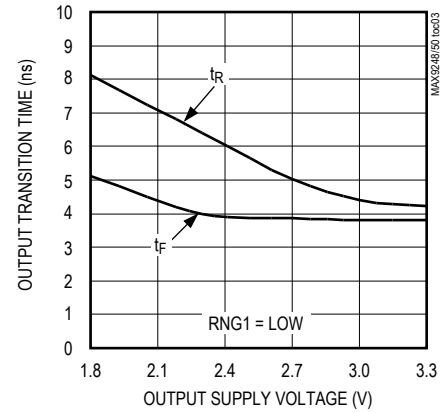

OUTPUT POWER SPECTRUM vs. FREQUENCY (REFCLK = 42MHz, NO SPREAD, 4%, AND 2% SPREAD)

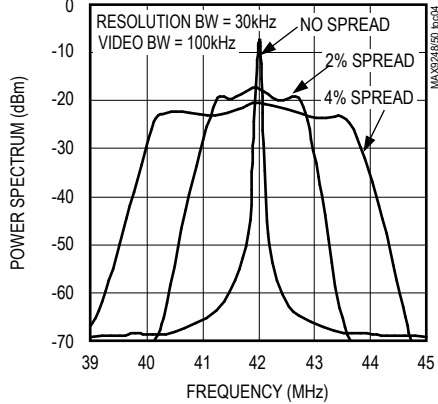

BIT-ERROR RATE vs. CABLE LENGTH

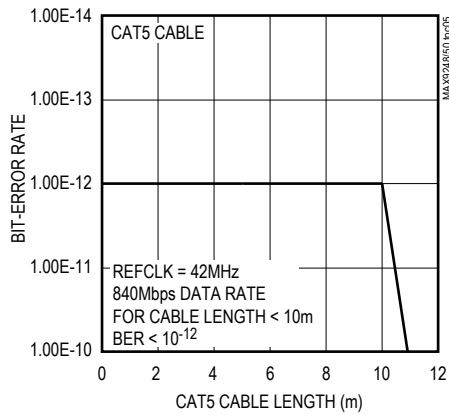

CABLE LENGTH vs. FREQUENCY BIT-ERROR RATE < 10⁻⁹

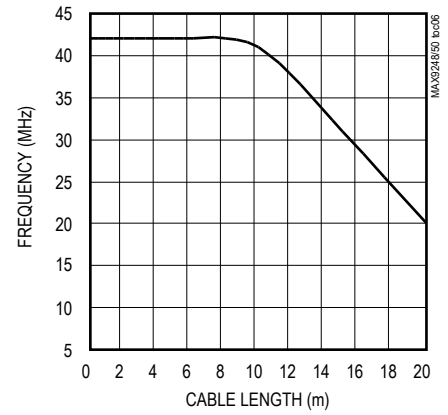

Pin Configuration

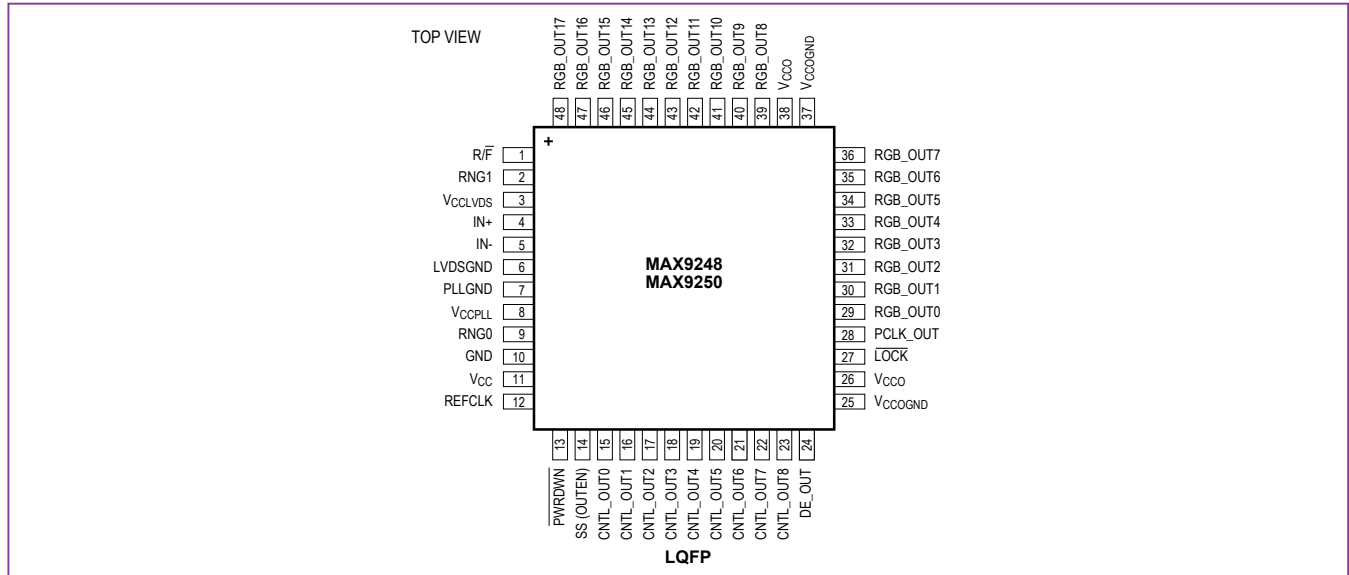

Pin Description

PIN		NAME	FUNCTION
MAX9248	MAX9250		
1	1	R/ \bar{F}	Rising or Falling Latch Edge Select. LVTTTL/LVCMOS input. Selects the edge of PCLK_OUT for latching data into the next chip. Set R/ \bar{F} = high for a rising latch edge. Set R/ \bar{F} = low for a falling latch edge. Internally pulled down to GND.
2	2	RNG1	LVTTTL/LVCMOS Range Select Input. Set to the range that includes the serializer parallel clock input frequency. Internally pulled down to GND.
3	3	V _{CCLVDS}	LVDS Supply Voltage. Bypass to LVDSGND with 0.1 μ F and 0.001 μ F capacitors in parallel as close to the device as possible, with the smallest value capacitor closest to the supply pin.
4	4	IN+	Noninverting LVDS Serial-Data Input
5	5	IN-	Inverting LVDS Serial-Data Input
6	6	LVDSGND	LVDS Supply Ground
7	7	PLLGND	PLL Supply Ground
8	8	V _{CCPLL}	PLL Supply Voltage. Bypass to PLLGND with 0.1 μ F and 0.001 μ F capacitors in parallel as close to the device as possible with the smallest value capacitor closest to the supply pin.
9	9	RNG0	LVTTTL/LVCMOS Range Select Input. Set to the range that includes the serializer parallel clock input frequency. Internal pulldown to GND.
10	10	GND	Digital Supply Ground
11	11	V _{CC}	Digital Supply Voltage. Supply for LVTTTL/LVCMOS inputs and digital circuits. Bypass to GND with 0.1 μ F and 0.001 μ F capacitors in parallel as close to the device as possible with the smallest value capacitor closest to the supply pin.
12	12	REFCLK	LVTTTL/LVCMOS Reference Clock Input. Apply a reference clock that is within $\pm 2\%$ of the serializer PCLK_IN frequency. Internally pulled down to GND.

Pin Description (continued)

PIN		NAME	FUNCTION
MAX9248	MAX9250		
13	13	$\overline{\text{PWRDWN}}$	LVTTL/LVCMOS Power-Down Input. Internally pulled down to GND.
14	—	SS	LVTTL/LVCMOS Spread-Spectrum Input. SS selects the frequency spread of PCLK_OUT and output data relative to PCLK_IN. Drive SS high for 4% spread and pull low for 2% spread.
15–23	15–23	CNTL_OUT0–CNTL_OUT8	LVTTL/LVCMOS Control Data Outputs. CNTL_OUT[8:0] are latched into the next chip on the rising or falling edge of PCLK_OUT as selected by R/ $\overline{\text{F}}$ when DE_OUT is low, and are held at the last state when DE_OUT is high.
24	24	DE_OUT	LVTTL/LVCMOS Data-Enable Output. High indicates RGB_OUT[17:0] are active. Low indicates CNTL_OUT[8:0] are active.
25, 37	25, 37	V _{CCOGND}	Output Supply Ground
26, 38	26, 38	V _{CCO}	Output Supply Voltage. Bypass to GND with 0.1 μ F and 0.001 μ F capacitors in parallel as close to the device as possible with the smallest value capacitor closest to the supply pin.
27	27	$\overline{\text{LOCK}}$	LVTTL/LVCMOS Lock Indicator Output. Outputs are valid when $\overline{\text{LOCK}}$ is low.
28	28	PCLK_OUT	LVTTL/LVCMOS Parallel Clock Output. Latches data into the next chip on the edge selected by R/ $\overline{\text{F}}$.
29–36, 39–48	29–36, 39–48	RGB_OUT0–RGB_OUT7, RGB_OUT8–RGB_OUT17	LVTTL/LVCMOS Red, Green, and Blue Digital Video Data Outputs. RGB_OUT[17:0] are latched into the next chip on the edge of PCLK_OUT selected by R/ $\overline{\text{F}}$ when DE_OUT is high, and are held at the last state when DE_OUT is low.
—	14	OUTEN	LVTTL/LVCMOS Output Enable Input. High activates the single-ended outputs. Driving low places the single-ended outputs in high impedance except $\overline{\text{LOCK}}$. Internally pulled down to GND.

Functional Diagram

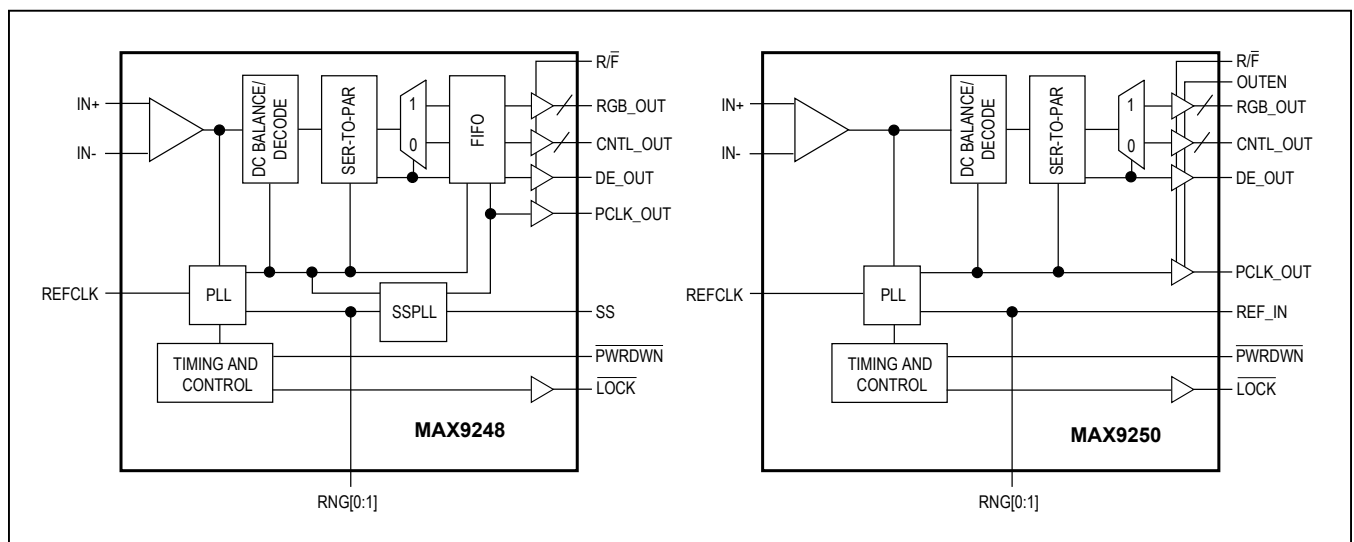

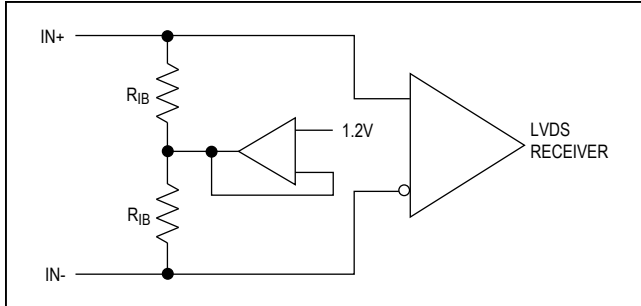

Figure 1. LVDS Input Bias

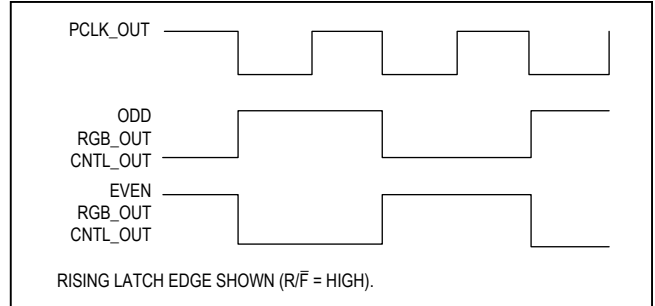

Figure 2. Worst-Case Output Pattern

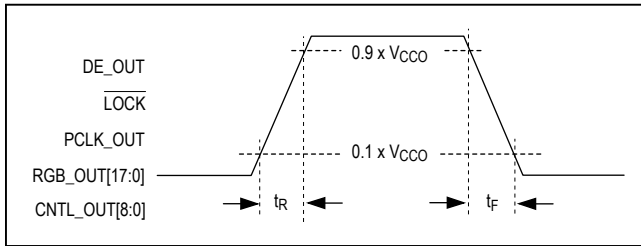

Figure 3. Output Rise and Fall Times

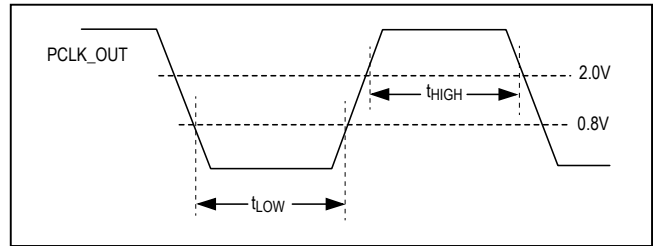

Figure 4. High and Low Times

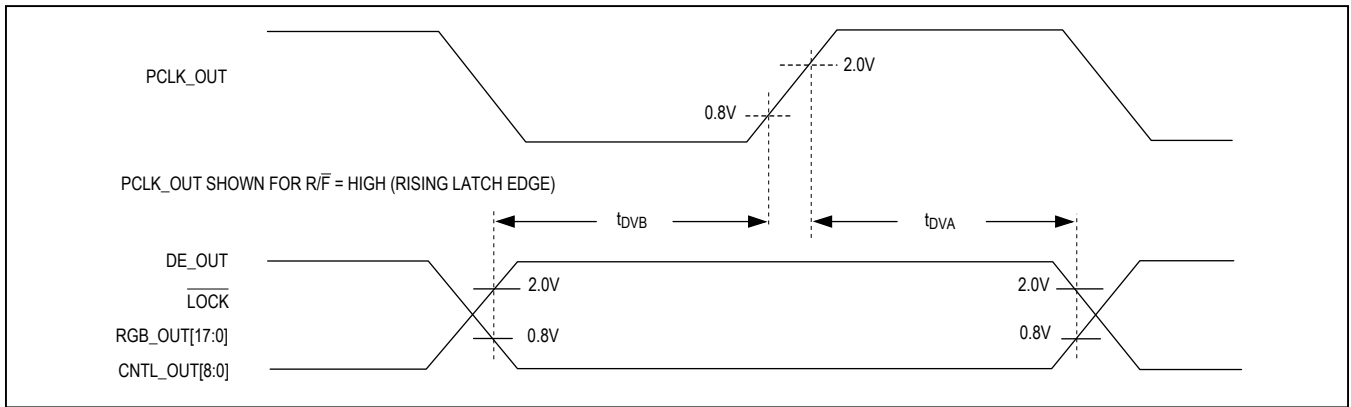

Figure 5. Synchronous Output Timing

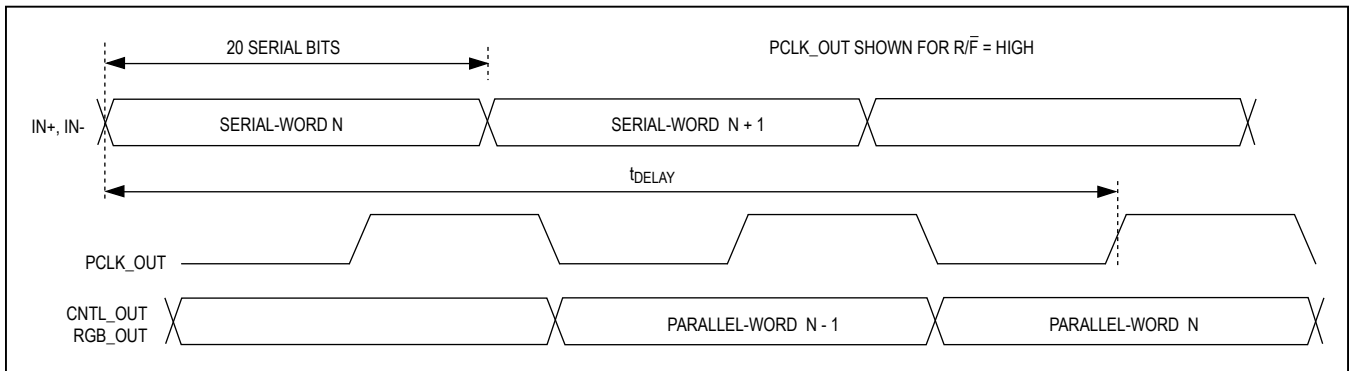

Figure 6. Deserializer Delay

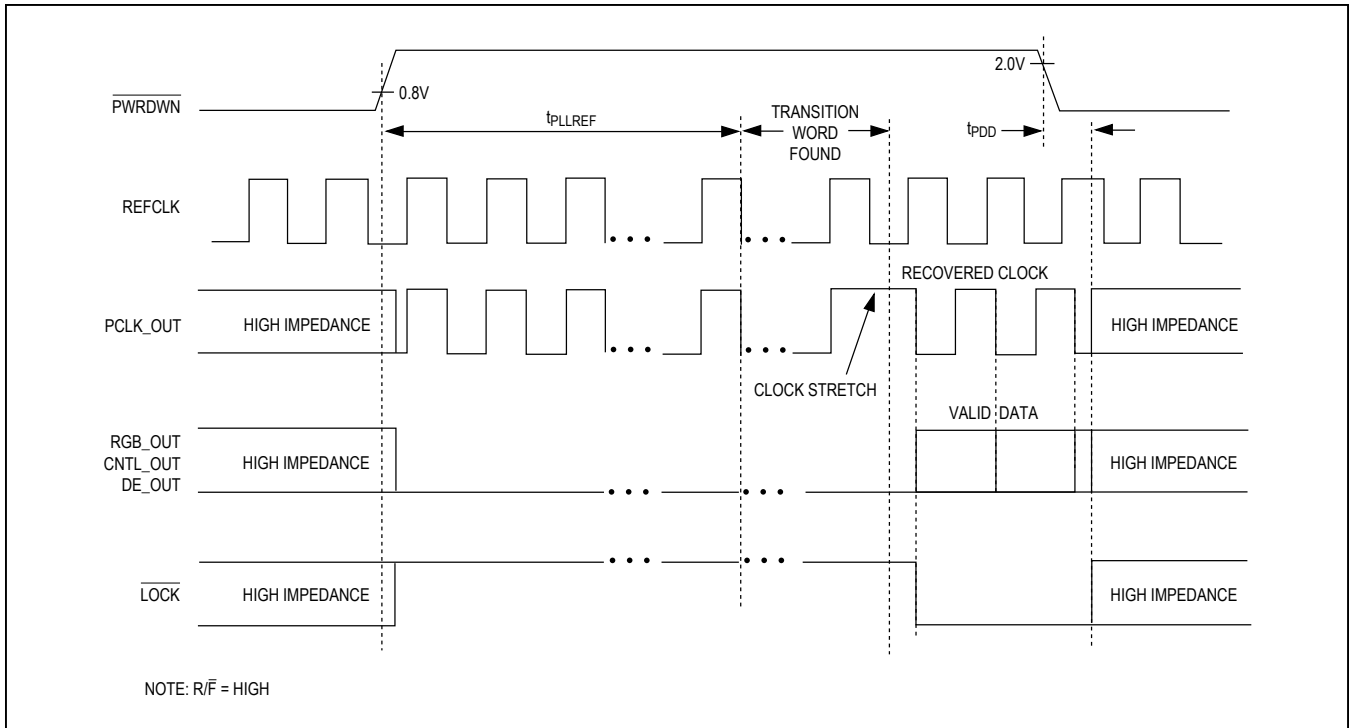

Figure 7. PLL Lock to REFCLK and Power-Down Delay for MAX9250

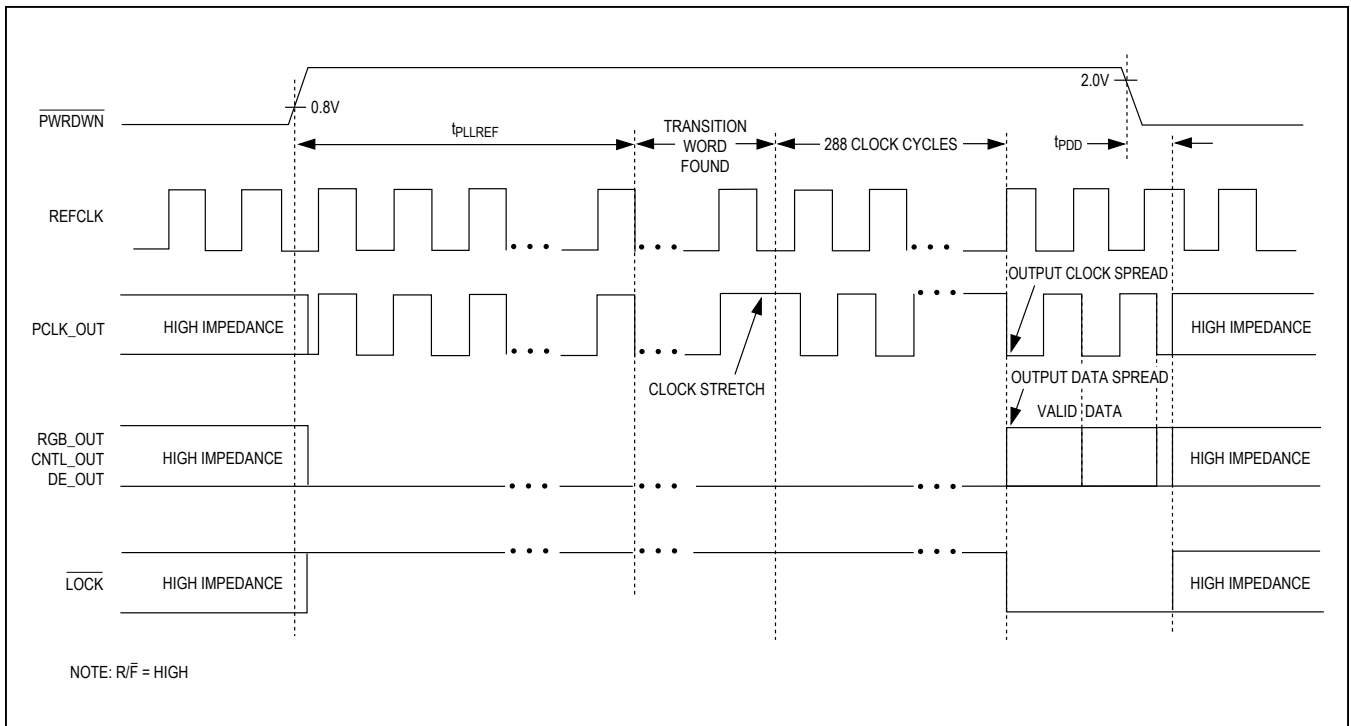

Figure 8. PLL Lock to REFCLK and Power-Down Delay for MAX9248

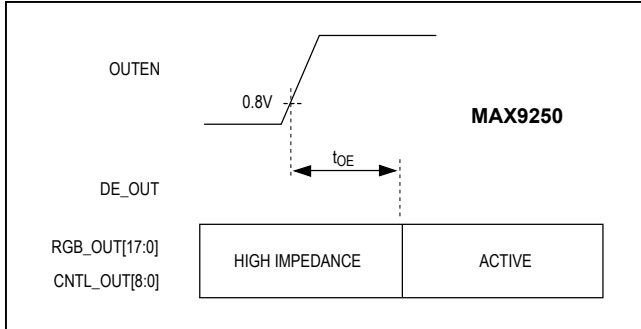

Figure 9. Output Enable Time

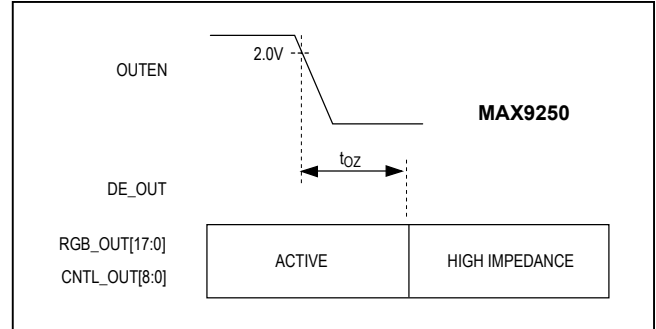

Figure 10. Output Disable Time

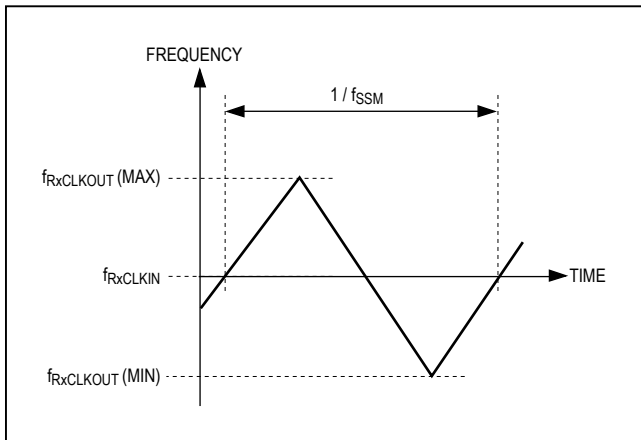

Figure 11. Simplified Modulation Profile

Detailed Description

The MAX9248/MAX9250 DC-balanced deserializers operate at a 5MHz-to-42MHz parallel clock frequency, deserializing video data to the RGB_OUT[17:0] outputs when the data-enable output DE_OUT is high, or control data to the CNTL_OUT[8:0] outputs when DE_OUT is low. The outputs on the MAX9248 are programmable for $\pm 2\%$ or $\pm 4\%$ spread relative to the LVDS input clock frequency, while the MAX9250 has no spread, but has an output-enable input that allows output busing. The video phase words are decoded using two overhead bits (EN0 and EN1). Control phase words are decoded with one overhead bit (EN0). Encoding, performed by the MAX9247 serializer, reduces EMI and maintains DC balance across the serial cable. The serial-input word formats are shown in [Table 1](#) and [Table 2](#).

Control data inputs C0 to C4, each repeated over three serial bit times by the serializer, are decoded using majority voting. Two or three bits at the same state determine the state of the recovered bit, providing single bit-error tolerance for C0 to C4. The state of C5 to C8 is determined by the level of the bit itself (no voting is used).

AC-Coupling Benefits

AC-coupling increases the input voltage of the LVDS receiver to the voltage rating of the capacitor. Two capacitors are sufficient for isolation, but four capacitors—two at the serializer output and two at the deserializer input—provide protection if either end of the cable is shorted to a high voltage. AC-coupling blocks low-frequency ground shifts and common-mode noise.

The MAX9247 serializer can also be DC-coupled to the MAX9248/MAX9250 deserializers. [Figure 12](#) and [Figure 14](#) show the AC-coupled serializer and deserializer with two capacitors per link, and [Figure 13](#) and [Figure 15](#) show the AC-coupled serializer and deserializer with four capacitors per link.

Applications Information

Selection of AC-Coupling Capacitors

See [Figure 16](#) for calculating the capacitor values for AC-coupling depending on the parallel clock frequency. The plot shows capacitor values for two- and four-capacitor-per-link systems. For applications using less than 18MHz clock frequency, use 0.1 μ F capacitors.

Termination and Input Bias

The IN+ and IN- LVDS inputs are internally connected to +1.2V through 42k Ω (min) to provide biasing for AC-coupling ([Figure 1](#)). Assuming 100 Ω interconnect, the LVDS input can be terminated with a 100 Ω resistor. Match the termination to the differential impedance of the interconnect.

Use a Thevenin termination, providing 1.2V bias, on an AC-coupled link in noisy environments. For interconnect with 100 Ω differential impedance, pull each LVDS line up to V_{CC} with 130 Ω and down to ground with 82 Ω at the deserializer input ([Figure 12](#) and [Figure 15](#)). This termination provides both differential and common-mode termination. The impedance of the Thevenin termination should be half the differential impedance of the interconnect and provide a bias voltage of 1.2V.

Table 1. Serial Video Phase Word Format

0	1	2	3	4	5	6	7	8	9	10	11	12	13	14	15	16	17	18	19
EN0	EN1	S0	S1	S2	S3	S4	S5	S6	S7	S8	S9	S10	S11	S12	S13	S14	S15	S16	S17

Bit 0 is the LSB and is deserialized first. EN[1:0] are encoding bits. S[17:0] are encoded symbols.

Table 2. Serial Control Phase Word Format

0	1	2	3	4	5	6	7	8	9	10	11	12	13	14	15	16	17	18	19
EN0	C0	C0	C0	C1	C1	C1	C2	C2	C2	C3	C3	C3	C4	C4	C4	C5	C6	C7	C8

Bit 0 is the LSB and is deserialized first. C[8:0] are the mapped control inputs.

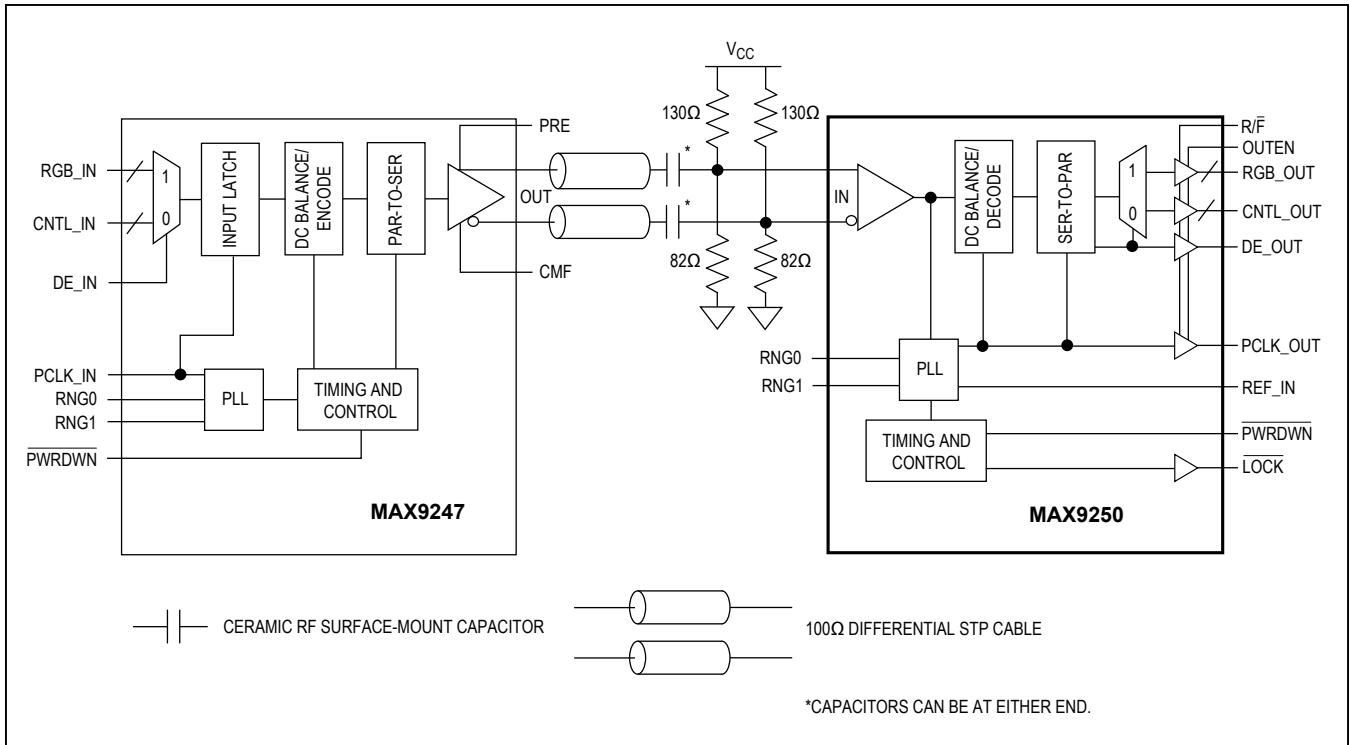

Figure 12. AC-Coupled MAX9247 Serializer and MAX9250 Deserializer with Two Capacitors per Link

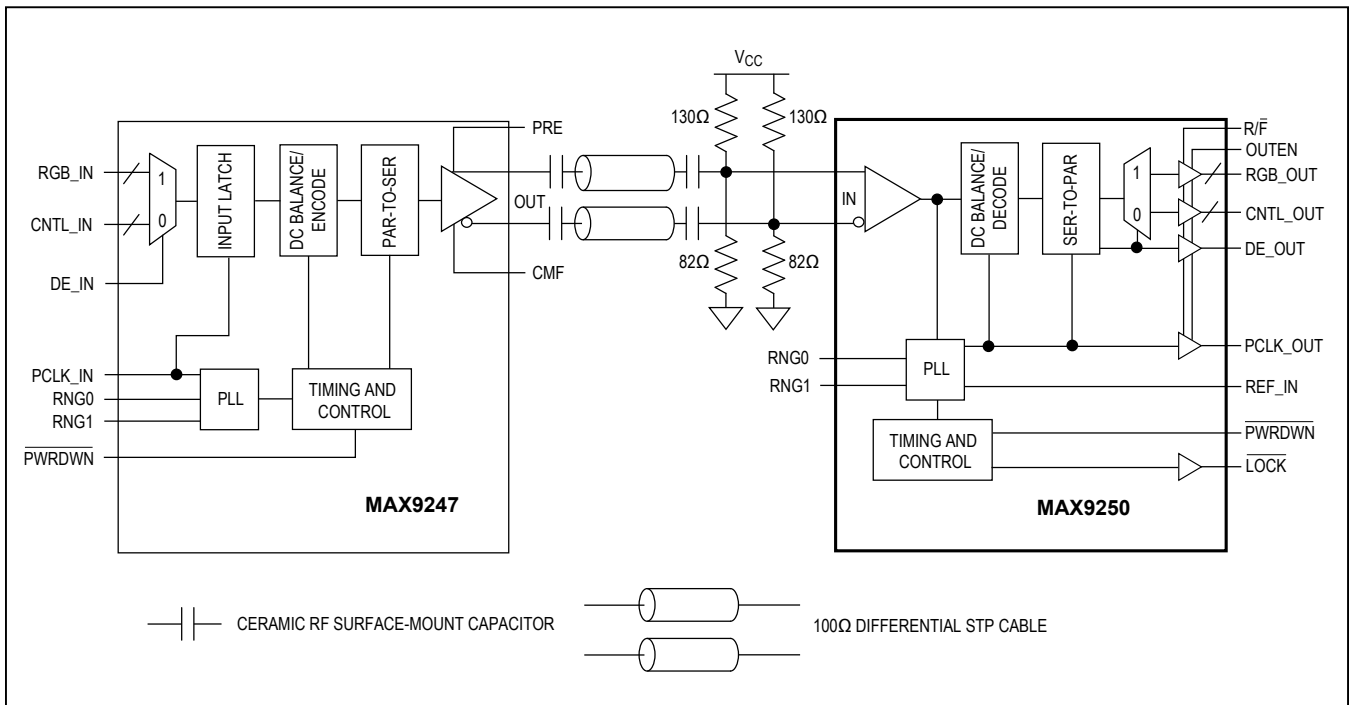

Figure 13. AC-Coupled MAX9247 Serializer and MAX9250 Deserializer with Four Capacitors per Link

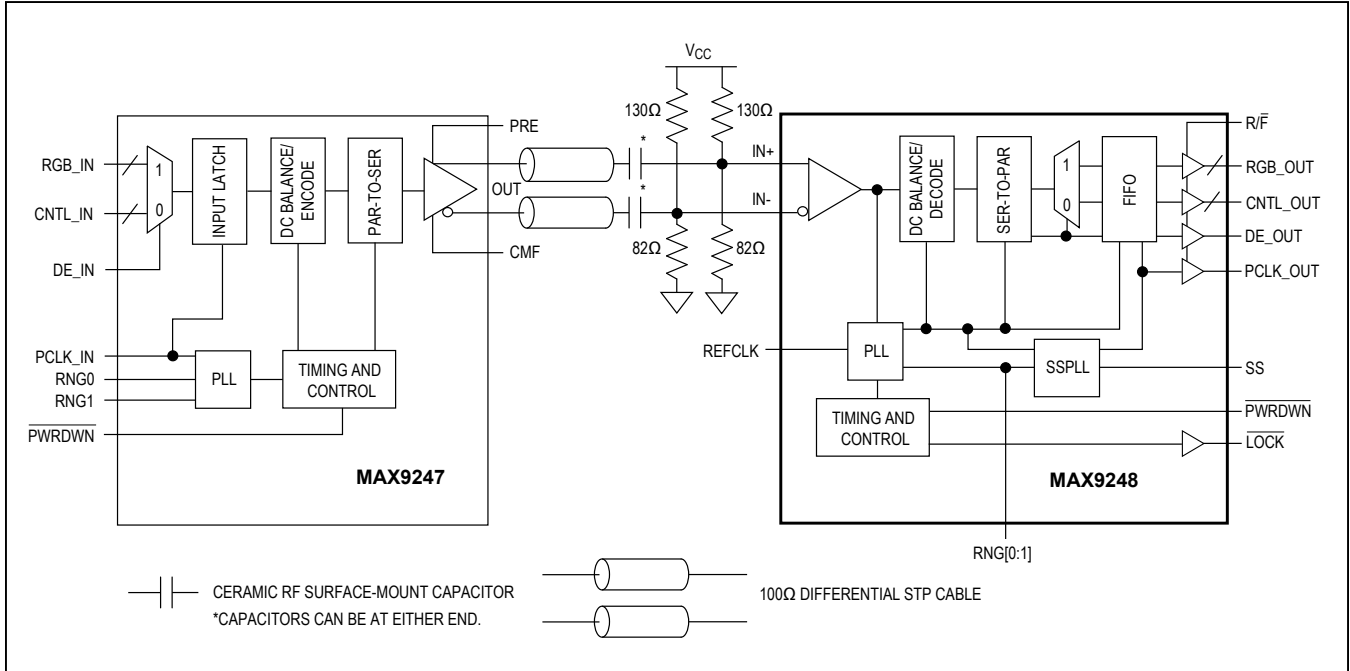

Figure 14. AC-Coupled MAX9247 Serializer and MAX9248 Deserializer with Two Capacitors per Link

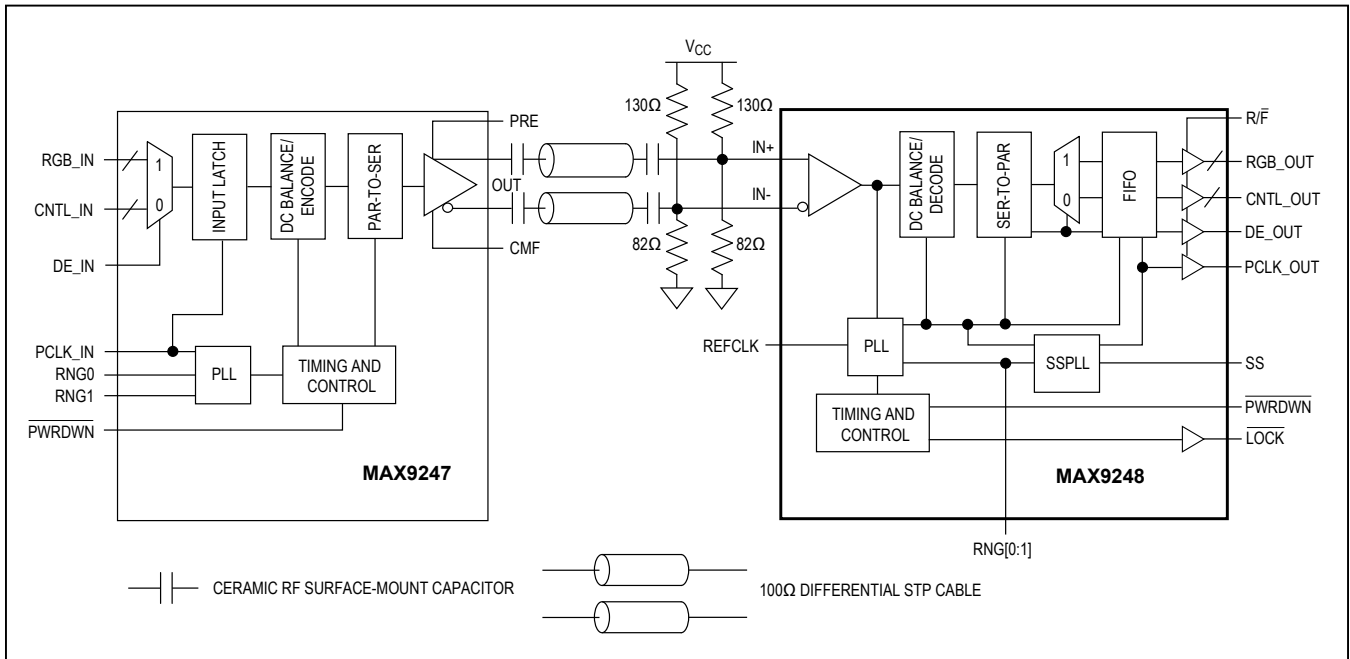

Figure 15. AC-Coupled MAX9247 Serializer and MAX9248 Deserializer with Four Capacitors per Link

Input Frequency Detection

A frequency-detection circuit detects when the LVDS input is not switching. When not switching, all outputs except $\overline{\text{LOCK}}$ are low, $\overline{\text{LOCK}}$ is high, and PCLK_OUT follows REFCLK. This condition occurs, for example, if the serializer is not driving the interconnect or if the interconnect is open.

Frequency Range Setting (RNG[1:0])

The RNG[1:0] inputs select the operating frequency range of the MAX9248/MAX9250 and the transition time of the outputs. Select the frequency range that includes the MAX9247 serializer PCLK_IN frequency. Table 3 shows the selectable frequency ranges and the corresponding data rates and output-transition times.

Power Down

Driving $\overline{\text{PWRDWN}}$ low puts the outputs in high impedance and stops the PLL. With $\overline{\text{PWRDWN}} \leq 0.3\text{V}$ and all LVTTTL/LVCMOS inputs $\leq 0.3\text{V}$ or $\geq V_{\text{CC}} - 0.3\text{V}$, the supply current is reduced to less than 50 μA . Driving $\overline{\text{PWRDWN}}$ high initiates lock to the local reference clock (REFCLK) and afterwards to the serial input.

Lock and Loss-of-Lock ($\overline{\text{LOCK}}$)

When $\overline{\text{PWRDWN}}$ is driven high, the PLL begins locking to REFCLK, drives $\overline{\text{LOCK}}$ from high impedance to high, and the other outputs from high impedance to low, except PCLK_OUT. PCLK_OUT outputs REFCLK while the PLL is locking to REFCLK. Lock to REFCLK takes a maximum of 16,928 REFCLK cycles for the MAX9250. The MAX9248 has an additional spread-spectrum PLL (SSPLL) that also begins locking to REFCLK. Locking both PLLs to REFCLK takes a maximum of 33,600 REFCLK cycles for the MAX9248.

Table 3. Frequency Range Programming

RNG1	RNG0	PARALLEL CLOCK (MHz)	SERIAL-DATA RATE (Mbps)	OUTPUT-TRANSITION TIME
0	0	Do not use		Slow
0	1	5 to 10	100 to 200	
1	0	10 to 20	200 to 400	Fast
1	1	20 to 42	400 to 840	

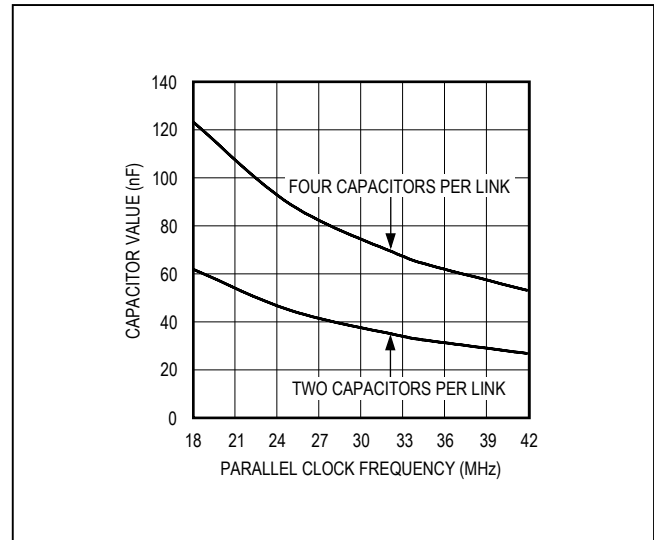

Figure 16. AC-Coupling Capacitor Values vs. Clock Frequency of 18MHz to 42MHz

When the MAX9248/MAX9250 complete their lock to REFCLK, the serial input is monitored for a transition word. When a transition word is found, $\overline{\text{LOCK}}$ output is driven low, indicating valid output data and the parallel rate clock recovered from the serial input is output on PCLK_OUT. The MAX9248 SSPLL waits an additional 288 clock cycles after the transition word is found before $\overline{\text{LOCK}}$ is driven low and sequence takes effect. PCLK_OUT is stretched on the change from REFCLK to recovered clock (or vice versa) at the time when the transition word is found.

If a transition word is not detected within 222 cycles of PCLK_OUT, $\overline{\text{LOCK}}$ is driven high; the other outputs except PCLK_OUT are driven low. REFCLK is output on PCLK_OUT and the deserializer continues monitoring the serial input for a transition word. See Figure 7 for the MAX9250 and Figure 8 for the MAX9248 regarding the synchronization timing diagram.

The MAX9248 input-to-output delay can be as low as $(4.5t_T + 8.0)\text{ns}$ or as high as $(36t_T + 16)\text{ns}$ due to spread-spectrum variations (see Figure 6).

The MAX9250 input-to-output delay can be as low as $(3.575t_T + 8)\text{ns}$ or as high as $(3.725t_T + 16)\text{ns}$.

Spread-Spectrum Selection

The MAX9248 single-ended data and clock outputs are programmable for a variation of ±2% or ±4% around the LVDS input clock frequency. The modulation rate of the frequency variation is 32kHz for a 33MHz LVDS clock input and scales linearly with the clock frequency (see Table 4). The output spread is controlled through the SS input (see Table 5). Driving SS high spreads all data and clock outputs by ±4%, while pulling low spreads ±2%.

Table 4. Modulation Rate

f _{PCLK_IN}	f _M (kHz) = f _{PCLK_IN} /1024
8	7.81
10	9.77
16	15.63
32	31.25
40	39.06
42	41.01

Table 5. SS Function

SS INPUT LEVEL	OUTPUT SPREAD
High	Data and clock output spread ±4% relative to REFCLK
Low	Data and clock output spread ±2% relative to REFCLK

Any spread change causes a delay time of 32,000 x t_r before output data is valid. When the spread amount is changed from ±2% to ±4% or vice versa, the data outputs go low for one t_{ΔSSPLL} delay (see Figure 17). The data outputs stay low, but are not valid when the spread amount is changed.

Output Enable (OUTEN) and Busing Outputs

The outputs of two MAX9250s can be used to form a 2:1 mux with the outputs controlled by the output enable. Wait 30ns between disabling one deserializer (driving OUTEN low) and enabling the second one (driving OUTEN high) to avoid contention of the bused outputs. OUTEN controls all outputs except LOCK.

Rising or Falling Output Latch Edge (R/F)

The MAX9248/MAX9250 have a selectable rising or falling output-latch edge through a logic setting on R/F. Driving R/F high selects the rising output-latch edge, which latches the parallel output data into the next chip on the rising edge of PCLK_OUT. Driving R/F low selects the falling output-latch edge, which latches the parallel output data into the next chip on the falling edge of PCLK_OUT. The MAX9248/MAX9250 output-latch-edge polarity does not need to match the MAX9247 serializer input-latch-edge polarity. Select the latch-edge polarity required by the chip being driven by the MAX9248/MAX9250.

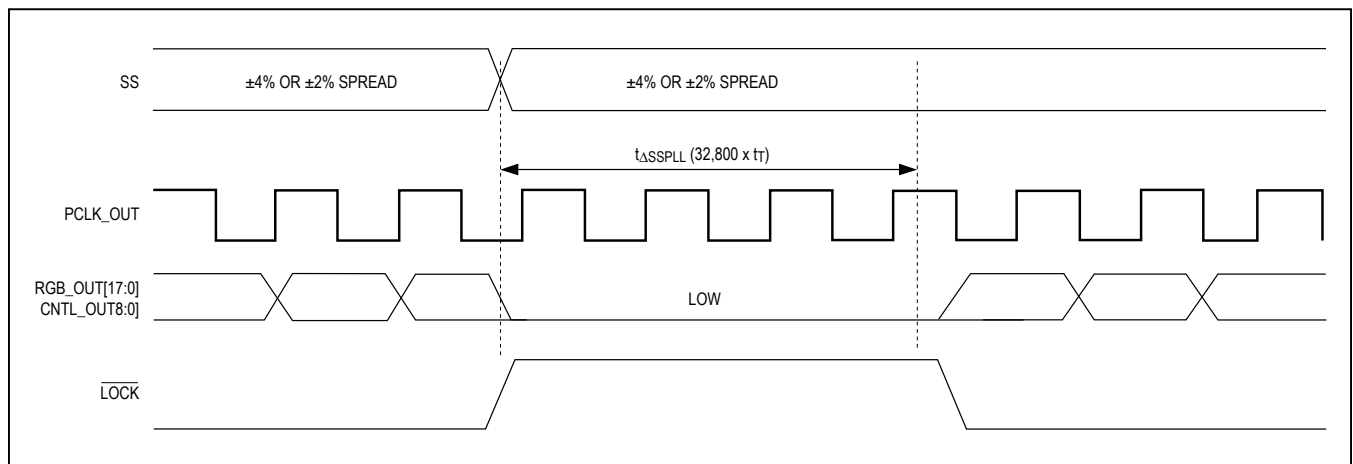

Figure 17. Output Waveforms when Spread Amount is Changed

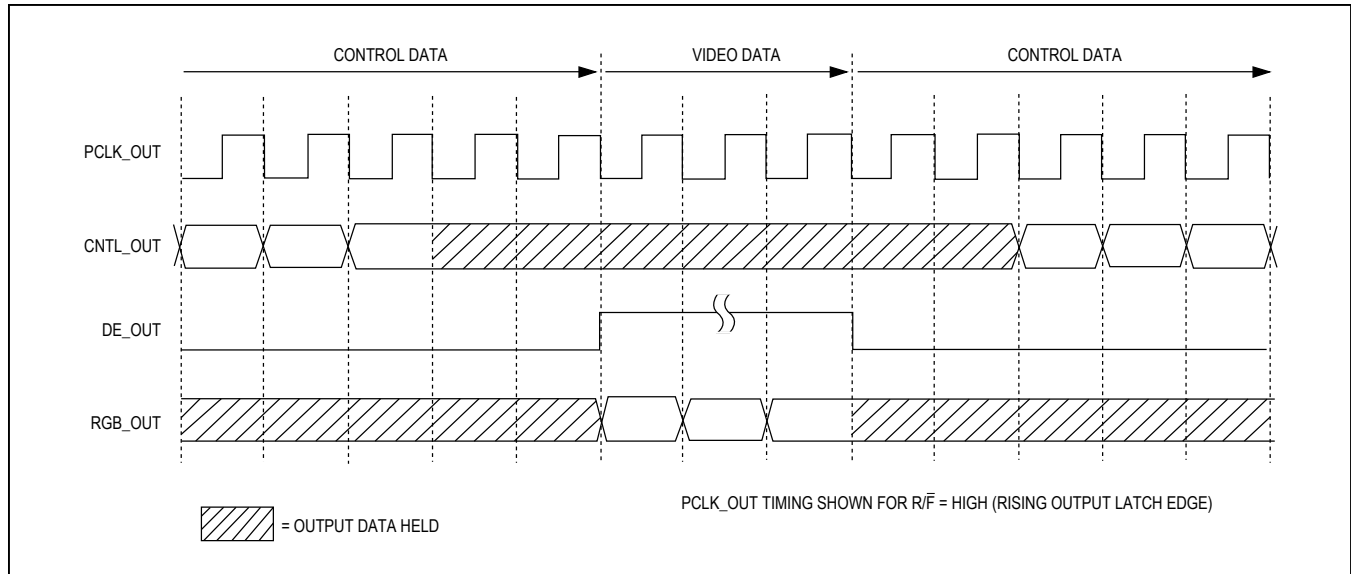

Figure 18. Output Timing

Staggered and Transition Time Adjusted Outputs

RGB_OUT[17:0] are grouped into three groups of six, with each group switching about 1ns apart in the video phase to reduce EMI and ground bounce. CNTL_OUT[8:0] switch during the control phase. Output transition time is slower in the 5MHz to 10MHz range and faster in the 10MHz to 20MHz and 20MHz to 42MHz ranges.

Data-Enable Output (DE_OUT)

The MAX9248/MAX9250 deserialize video and control data at different times. Control data is deserialized during the video blanking time. DE_OUT high indicates that video data is being deserialized and output on RGB_OUT[17:0]. DE_OUT low indicates that control data is being deserialized and output on CNTL_OUT[8:0]. When outputs are not being updated, the last data received is latched on the outputs. [Figure 18](#) shows the DE_OUT timing.

Power-Supply Sequencing of the MAX9247 and MAX9248/MAX9250 Video Link

The MAX9247 and MAX9248/MAX9250 video link can be powered up in several ways. The best approach is to keep both MAX9247 and MAX9248 powered down while supplies are ramping up and PCLK_IN of the MAX9247 and REFCLK of the MAX9248/MAX9250 are stabilizing. After all the power supplies of the MAX9247 and MAX9248/MAX9250 are stable, including PCLK_IN and REFCLK, do the following:

- Power up the MAX9247 first with high-transition density data (e.g., PRBS, checkboard)
- Wait for at least t_{LOCK} of MAX9247 (or $17100 \times t_T$) to get activity on the link
- Power up the MAX9248

Power-Supply Circuits and Bypassing

There are separate on-chip power domains for digital circuits and LVTTTL/LVCMOS inputs (V_{CC} supply and GND), outputs (V_{CCO} supply and V_{CCOGND}), PLL (V_{CCPLL} supply and PLL_{GND}), and the LVDS input (V_{CCLVDS} supply and $LVDS_{GND}$). The grounds are isolated by diode connections. Bypass each V_{CC} , V_{CCO} , V_{CCPLL} , and V_{CCLVDS} pin with high-frequency, surface-mount ceramic 0.1 μ F and 0.001 μ F capacitors in parallel as close to the device as possible, with the smallest value capacitor closest to the supply pin. The outputs are powered from V_{CCO} , which accepts a 1.71V to 3.6V supply, allowing direct interface to inputs with 1.8V to 3.3V logic levels.

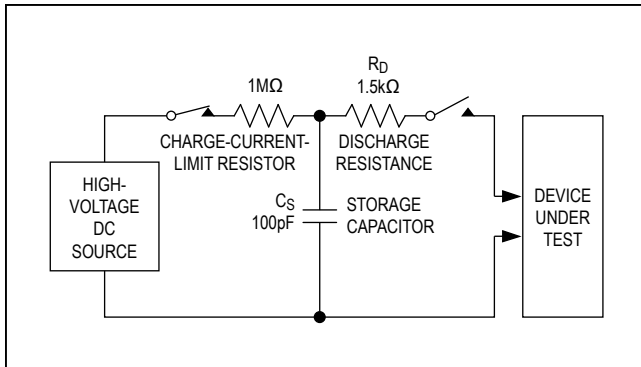

Figure 19. Human Body ESD Test Circuit

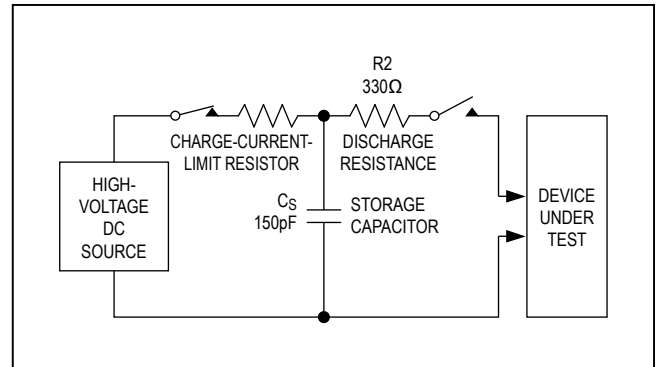

Figure 20. IEC 61000-4-2 Contact Discharge ESD Test Circuit

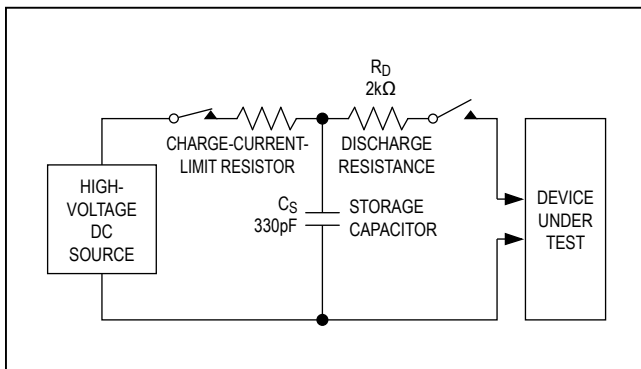

Figure 21. ISO 10605 Contact Discharge ESD Test Circuit

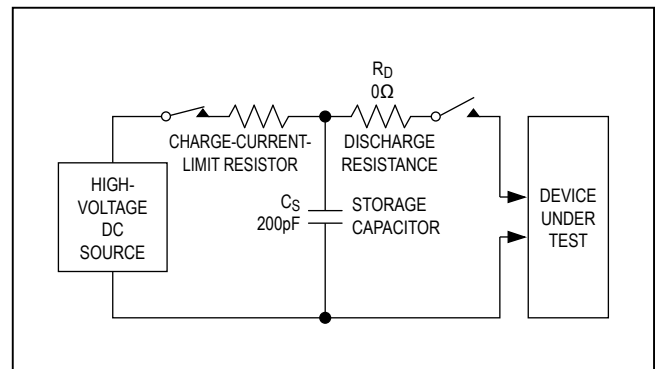

Figure 22. Machine Model ESD Test Circuit

Cables and Connectors

Interconnect for LVDS typically has a differential impedance of 100Ω. Use cables and connectors that have matched differential impedance to minimize impedance discontinuities.

Twisted-pair and shielded twisted-pair cables offer superior signal quality compared to ribbon cable, and tend to generate less EMI due to magnetic field-canceling effects. Balanced cables pick up noise as common mode, which is rejected by the LVDS receiver.

Board Layout

Separate the LVTTTL/LVCMOS outputs and LVDS inputs to prevent crosstalk. A four-layer PCB with separate layers for power, ground, and signals is recommended.

ESD Protection

The MAX9248/MAX9250 ESD tolerance is rated for Human Body Model, Machine Model, IEC 61000-4-2, and ISO 10605. The ISO 10605 and IEC 61000-4-2 standards specify ESD tolerance for electronic systems. All LVDS inputs on the MAX9248/MAX9250 meet ISO 10605 ESD protection at ±30kV Air-Gap Discharge and ±10kV Contact Discharge and IEC 61000-4-2 ESD protection at ±15kV Air-Gap Discharge and ±10kV Contact Discharge. All other pins meet the Human Body Model ESD tolerance of ±2kV. The Human Body Model discharge components are $C_S = 100\text{pF}$ and $R_D = 1.5\text{k}\Omega$ (Figure 19). The IEC 61000-4-2 discharge components are $C_S = 150\text{pF}$ and $R_D = 330\Omega$ (Figure 20). The ISO 10605 discharge components are $C_S = 330\text{pF}$ and $R_D = 2\text{k}\Omega$ (Figure 21). The Machine Model discharge components are $C_S = 200\text{pF}$ and $R_D = 0\Omega$ (Figure 22).

Ordering Information

PART	TEMP RANGE	PIN-PACKAGE
MAX9248 ECM+	-40°C to +85°C	48 LQFP
MAX9248ECM/V+	-40°C to +85°C	48 LQFP
MAX9248GCM+	-40°C to +105°C	48 LQFP
MAX9248GCM/V+	-40°C to +105°C	48 LQFP
MAX9250 ECM+	-40°C to +85°C	48 LQFP
MAX9250ECM/V+	-40°C to +85°C	48 LQFP
MAX9250GCM+	-40°C to +105°C	48 LQFP
MAX9250GCM/V+	-40°C to +105°C	48 LQFP

+Denotes a lead(Pb)-free/RoHS-compliant package.

/V denotes an automotive qualified part.

Chip Information

PROCESS: CMOS

Package Information

For the latest package outline information and land patterns (footprints), go to www.maximintegrated.com/packages. Note that a "+", "#", or "-" in the package code indicates RoHS status only. Package drawings may show a different suffix character, but the drawing pertains to the package regardless of RoHS status.

PACKAGE TYPE	PACKAGE CODE	OUTLINE NO.	LAND PATTERN NO.
48 LQFP	C48+3	21-0054	90-0093

Revision History

REVISION NUMBER	REVISION DATE	DESCRIPTION	PAGES CHANGED
2	5/08	Replaced TQFP and TQFN packages with LQFP package, changed temperature limits for +105°C part, and added Machines Model ESD text and diagram	1–5, 7, 16–19
3	4/09	Added <i>IV</i> parts in the Ordering Information table and added new Power-Supply Sequencing of MAX9247 and MAX9248/MAX9250 Video Link section	1, 17
4	7/14	Clarified definition of test conditions and updated Package Information	4, 17, 19
5	6/17	Removed low-speed operation	1–20

For pricing, delivery, and ordering information, please contact Maxim Direct at 1-888-629-4642, or visit Maxim Integrated's website at www.maximintegrated.com.

Maxim Integrated cannot assume responsibility for use of any circuitry other than circuitry entirely embodied in a Maxim Integrated product. No circuit patent licenses are implied. Maxim Integrated reserves the right to change the circuitry and specifications without notice at any time. The parametric values (min and max limits) shown in the Electrical Characteristics table are guaranteed. Other parametric values quoted in this data sheet are provided for guidance.

Looking for pricing, stock, or lifecycle information?

Click below to explore more details on WIN SOURCE:

- ⊖ [View MAX9248ECM+T on WIN SOURCE](#)
- ⊖ [Maxim Integrated Information](#)

Optimize Your Supply Chain with WIN SOURCE Solutions

- ✓ Global Sourcing Solution
- ✓ Obsolete Management
- ✓ Cost Control Management
- ✓ Shortage Management
- ✓ Alternative Solution
- ✓ Excess Inventory Management