



**THE DATASHEET OF
MAX8680ETL+**



EVALUATION KIT
AVAILABLE



Smallest, All-Internal MOSFET, 7-Channel DSC PMIC in Tiny 5mm x 5mm Thin QFN

MAX8680

General Description

The MAX8680 highly efficient complete power-supply solution is designed for digital still cameras (DSCs) and digital video cameras (DVCs). The device integrates seven on-chip power MOSFET DC-DC converters with up to 95% efficiency to power all critical power supplies in DSC systems. Each converter also features True Shutdown™, as well as internal compensation to minimize external component count. The seven DC-DC converter outputs are:

- Step-up synchronous-rectified DC-DC converter (SU). The MAX8680 is bootstrapped from V_{SU}.
- MAIN synchronous-rectified step-down DC-DC converter (M) for DSP I/O supply voltage.
- DDRZ synchronous-rectified step-down DC-DC converter (Z) for DSP DDR supply voltage.
- Low-voltage (down to 1V) synchronous-rectified step-down DC-DC converter (SD) for DSP core supply voltage.
- High-voltage, step-up DC-DC converter with current regulation and PWM dimming control (LEDBST) for white LEDs (WLED).
- High-voltage step-up DC-DC converter (CCDBST) for CCD imagers or positive LCD bias supplies.
- Transformerless inverting DC-DC converter (CCDINV) for CCD imagers or negative LCD bias supplies.

The MAX8680 has an independent/simultaneous power-on sequence of the CCDBST and CCDINV converters. For a preset power-on sequence of CCDBST before CCDINV, contact the factory.

The MAX8680 operates with 1-cell lithium-ion (Li+) battery, two-AA cell, or dual-battery designs and is available in a 5mm x 5mm, 40-pin thin QFN package. The MAX8680 operates over the -40°C to +85°C extended temperature range.

Applications

- DSCs and DVCs
- PDAs and Portable Media Players
- GPS Navigation Systems

Ordering Information

PART	TEMP RANGE	PIN-PACKAGE	PKG CODE
MAX8680ETL+	-40°C to +85°C	40 Thin QFN-EP*	T4055-2

+Denotes a lead-free package.

*EP= Exposed paddle.

Features

- ◆ 95% Efficient Synchronous-Rectified DC-DC Converters
- ◆ 90% Efficient Boost-Buck Operation
- ◆ 85% Efficient DC-DC Converters for CCD, LCD, WLED, and/or OLED
- ◆ Internal Compensation on All Channels
- ◆ True Shutdown on All Step-Up Converters
- ◆ Overload Protection
- ◆ Soft-Start for Controlled Startup Current
- ◆ Dropout Operation (100% Duty Cycle) on Step-Down Converters
- ◆ Regulated Current Output for Up to 6 White LEDs
- ◆ PWM Dimming of WLED Current
- ◆ Adjustable LED Overvoltage Protection Up to 27V
- ◆ Transformerless Inverting Converter for CCD
- ◆ 2MHz Switching Frequency for Low-Voltage Channels
- ◆ ±2.5% Switching Frequency Accuracy
- ◆ 1µA Shutdown Supply Current
- ◆ Power-On Voltage Tracking for Core and Main Outputs
- ◆ All Internal Power MOSFETs
- ◆ SDOK Power-OK Indicator

Typical Operating Circuit

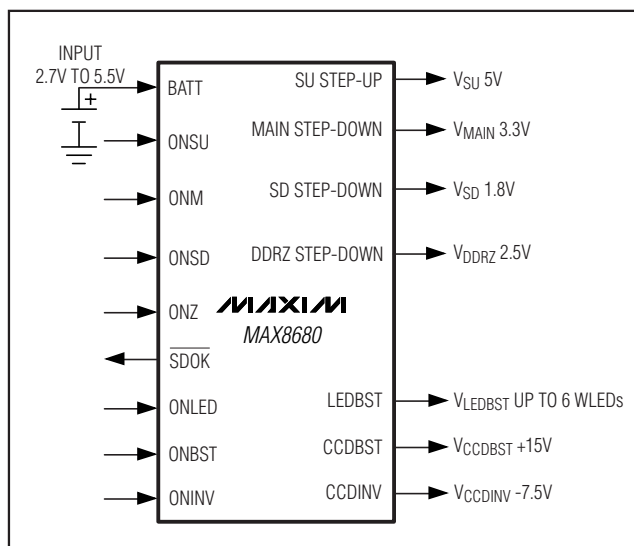

Pin Configuration appears at the end of data sheet.

True Shutdown is a trademark of Maxim Integrated Products, Inc.



Smallest, All-Internal MOSFET, 7-Channel DSC PMIC in Tiny 5mm x 5mm Thin QFN

MAX8680

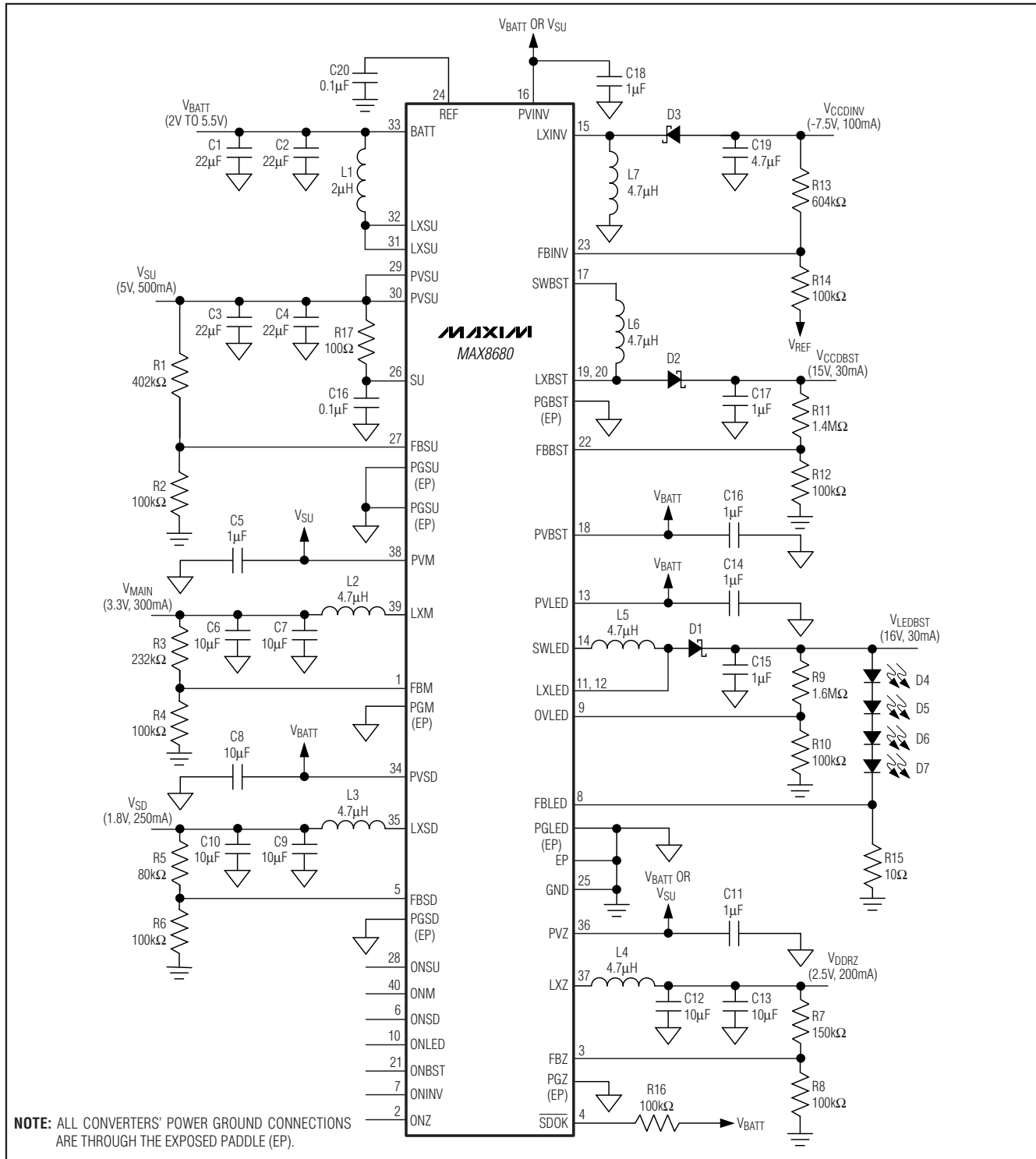

Figure 1. MAX8680 Typical Application Circuit (for Li+ Cell Design, Connect PVZ and PVINV to BATT; for Two-AA or Dual-Battery Design, Connect PVZ and PVINV to PVSU)

Looking for pricing, stock, or lifecycle information?

Click below to explore more details on WIN SOURCE:

- ⊖ [View MAX8680ETL+ on WIN SOURCE](#)
- ⊖ [Maxim Integrated Information](#)

Optimize Your Supply Chain with WIN SOURCE Solutions

- ✓ Global Sourcing Solution
- ✓ Obsolete Management
- ✓ Cost Control Management
- ✓ Shortage Management
- ✓ Alternative Solution
- ✓ Excess Inventory Management