



**THE DATASHEET OF
MAX8678ETE+T**



EVALUATION KIT
AVAILABLE

MAXIM

White LED Charge Pump with 1.1W Audio Amplifier

MAX8678

General Description

The MAX8678 integrates a charge pump for white light-emitting diodes (LEDs) with an audio loudspeaker amplifier. The high-efficiency, adaptive charge pump drives up to four LEDs with constant current for uniform brightness. The LED current is adjustable from 0.1mA/LED to 24mA/LED in 31 pseudo-logarithmic steps through a single-wire serial-pulse interface. High accuracy and LED-to-LED current matching are maintained throughout the adjustment range. Individual adaptive mode switching for each LED provides high efficiency with a wide range of LED forward voltages.

The mono class AB audio amplifier directly drives an 8Ω loudspeaker with 1.1W RMS continuous power from a 5V supply with less than 1% THD+N. The gain is adjustable from -9dB to +18dB in ten 3dB steps through a single-wire serial-pulse interface. Clicks and pops are suppressed during on/off and all gain adjustments. Differential inputs improve common-mode noise rejection.

The MAX8678 includes soft-start, thermal shutdown, open-circuit and short-circuit protection, and is available in the 16-pin, 3mm x 3mm Thin QFN package (0.8mm max height).

Applications

Cell Phones and Smartphones
Camera Phones
PDAs, Digital Cameras, Camcorders

Typical Operating Circuit

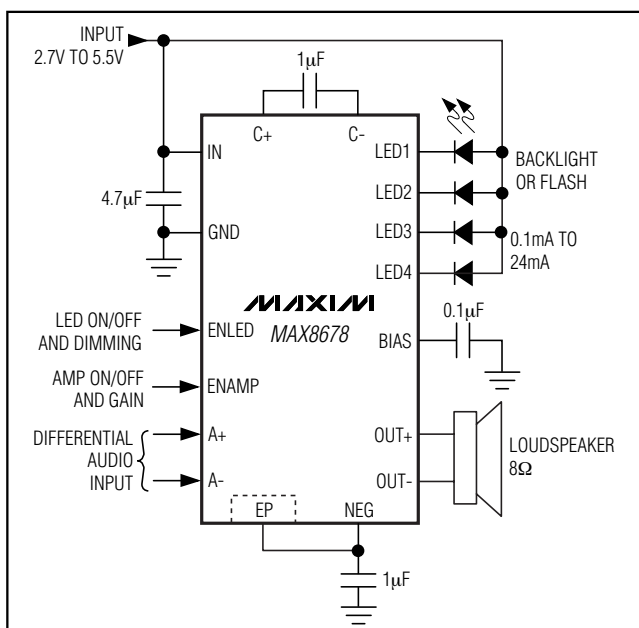

Features

- ◆ High-Efficiency White LED Charge Pump
 - Individual Adaptive Supply for Each LED
 - 4 Low-Dropout LED Current Regulators
 - 24mA to 0.1mA Dimming Range
 - Single-Wire, Serial-Pulse Dimming Interface
 - 1% (typ) Accuracy
 - Low 140µA Quiescent Current
- ◆ Mono Class AB Audio Amplifier
 - 1.1W RMS Mono BTL Output (8Ω, V_{IN} = 5V)
 - Low 0.004% THD+N at 1kHz
 - High 90dB PSRR at 1kHz
 - Fully Differential Inputs
 - 9dB to +18dB Gain Settings in 3dB Steps
 - Integrated Click/Pop Suppression
 - Low Quiescent Current
- ◆ Soft-Start Limits Inrush Current
- ◆ Thermal Shutdown, Open- and Short-Circuit Protection
- ◆ 16-Pin, 3mm x 3mm Thin QFN Package

Ordering Information

PART	PIN-PACKAGE	TOP MARK	PKG CODE
MAX8678ETE+	16 Thin QFN 3mm x 3mm	AFF	T1633-5

+Denotes a lead-free package.

Note: The device is specified over the -40°C to +85°C extended temperature range.

Pin Configuration

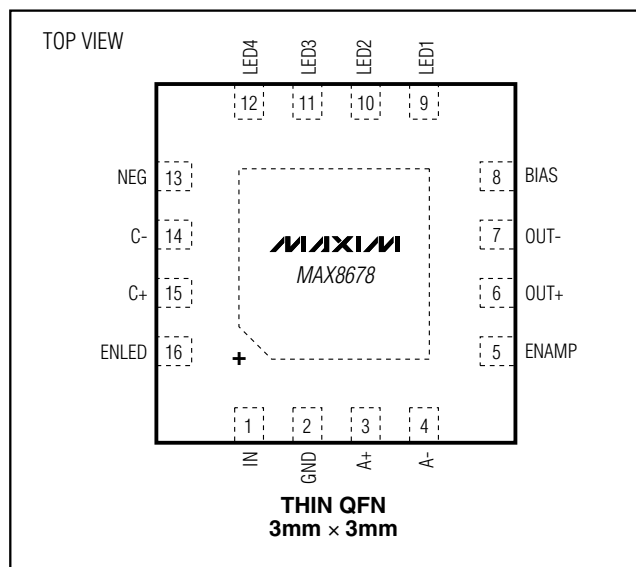

MAXIM

Maxim Integrated Products 1

For pricing, delivery, and ordering information, please contact Maxim Direct at 1-888-629-4642, or visit Maxim's website at www.maxim-ic.com.

White LED Charge Pump with 1.1W Audio Amplifier

ABSOLUTE MAXIMUM RATINGS

IN to GND	-0.3V to +6.0V	OUT+, OUT- Short Circuit to GND or IN	Continuous
IN to NEG	-0.3V to +6.0V	Continuous Power Dissipation ($T_A = +70^\circ\text{C}$)	
ENLED, ENAMP, LED_, C+, A+, A-, OUT+, OUT-, BIAS to GND	-0.3V to ($V_{IN} + 0.3\text{V}$)	16-Pin Thin QFN 3mm x 3mm (derate 17.5mW/ $^\circ\text{C}$ above $+70^\circ\text{C}$)	1398mW
ENLED, ENAMP, LED_, C+, A+, A-, OUT+, OUT-, BIAS, C- to NEG	-0.3V to ($V_{IN} + 0.3\text{V}$)	Junction Temperature	+150 $^\circ\text{C}$
GND to NEG	-0.3V to +6.0V	Storage Temperature Range	-65 $^\circ\text{C}$ to +150 $^\circ\text{C}$
GND to C-	-0.3V to +6.0V	Lead Temperature (soldering, 10s)	+300 $^\circ\text{C}$

Stresses beyond those listed under "Absolute Maximum Ratings" may cause permanent damage to the device. These are stress ratings only, and functional operation of the device at these or any other conditions beyond those indicated in the operational sections of the specifications is not implied. Exposure to absolute maximum rating conditions for extended periods may affect device reliability.

ELECTRICAL CHARACTERISTICS

($V_{IN} = 3.6\text{V}$, $V_{GND} = 0\text{V}$, $T_A = -40^\circ\text{C}$ to $+85^\circ\text{C}$, unless otherwise noted. Typical values are at $T_A = +25^\circ\text{C}$.) (Note 1)

PARAMETER	CONDITIONS		MIN	TYP	MAX	UNITS
IN Operating Voltage			2.7		5.5	V
Undervoltage-Lockout (UVLO) Threshold	V_{IN} rising		2.25	2.45	2.65	V
UVLO Hysteresis				100		mV
Shutdown Supply Current (All Outputs Off)	ENLED = ENAMP = GND	$T_A = +25^\circ\text{C}$		0.1	1.5	μA
		$T_A = +85^\circ\text{C}$		0.1		
No-Load Supply Current	Charge pump inactive, LED_ = 1.6mA ENAMP = GND, $T_A = +25^\circ\text{C}$			140	200	μA
	Charge pump active, 1MHz switching, LEDs at 24mA setting, ENAMP = GND			0.45		mA
	ENAMP = IN, ENLED = GND			3		
Thermal Shutdown				+160		$^\circ\text{C}$
Thermal-Shutdown Hysteresis				20		$^\circ\text{C}$
SERIAL-PULSE INTERFACE (EN_)						
Logic Input-High Voltage	$V_{IN} = 2.7\text{V}$ to 4.2V		1.4			V
	$V_{IN} = 4.2\text{V}$ to 5.5V		1.5			
Logic Input-Low Voltage	$V_{IN} = 2.7\text{V}$ to 5.5V				0.4	V
Logic Input Current	$V_{IL} = 0\text{V}$ or $V_{IH} = 5.5\text{V}$	$T_A = +25^\circ\text{C}$	0.01		1	μA
		$T_A = +85^\circ\text{C}$	0.1			
tSHDN	See Figures 2 and 3				3.2	ms
tHOLD	See Figures 2 and 3				3.2	ms
tLO	See Figures 2 and 3		0.5		500	μs
tHI	See Figures 2 and 3		0.5		500	μs
CHARGE PUMP						
Switching Frequency			1			MHz
Soft-Start Time			0.1			ms
Regulation Voltage (OVP) ($V_{IN} - V_{NEG}$)			5			V
Open-Loop NEG Output Resistance ($(V_{NEG} - V_{IN})/I_{NEG}$)			10	23		Ω
Guaranteed Output Current	LED $V_F = 3.9\text{V}$, $V_{IN} = 3.2\text{V}$		96			mA
NEG Discharge Resistance in Shutdown	All LEDs off, ENLED = GND		10			k Ω

White LED Charge Pump with 1.1W Audio Amplifier

MAX8678

ELECTRICAL CHARACTERISTICS (continued)

($V_{IN} = 3.6V$, $V_{GND} = 0V$, $T_A = -40^{\circ}C$ to $+85^{\circ}C$, unless otherwise noted. Typical values are at $T_A = +25^{\circ}C$.) (Note 1)

PARAMETER	CONDITIONS	MIN	TYP	MAX	UNITS
LED DRIVER					
Current-Setting Range		0.1		24.0	mA
Current Accuracy	24mA setting, $T_A = +25^{\circ}C$	-2	± 1	+2	%
	24mA setting, $T_A = -40^{\circ}C$ to $+85^{\circ}C$	-5		+5	
	1.6mA setting, $T_A = +25^{\circ}C$		± 5		
LED_ Dropout	24mA setting (Note 2)	Charge pump inactive	72	120	mV
		Charge pump active	132	360	
LED_ Voltage-Mode Transition Threshold (1x to 2x)	$V_{LED_falling}$	125	150	175	mV
LED_ Voltage-Mode Transition Hysteresis			100		mV
LED_ Leakage in Shutdown	All LEDs off	$T_A = +25^{\circ}C$	0.01	1	μA
		$T_A = +85^{\circ}C$	0.1		
AUDIO AMPLIFIER					
Common-Mode Bias Voltage		-5%	$V_{IN} / 2$	+5%	
Output Offset Voltage	$V_{A+} = V_{A-} = V_{BIAS}$, gain $\leq 12dB$	-25	± 1	+25	mV
Common-Mode Input Voltage		0.5		$(V_{IN} - 1.2)$	V
Input Impedance (R_{IN})	Table 2	10	67	140	k Ω
Common-Mode Rejection Ratio	$V_{IN} = 3.2V$	50	60		dB
	$f = 1kHz$, $V_{IN} = 3.2V$		70		
Power-Supply Rejection Ratio	$V_{A+} = V_{A-} = V_{BIAS}$, 200mV _{P-P} at IN	$f = 217Hz$	93		dB
		$f = 1kHz$	90		
Output Power	THD+N = 1%, $f = 1kHz$ (Note 3)	$R_L = 8\Omega$, $V_{IN} = 3.2V$	0.36	0.5	W
		$R_L = 4\Omega$, $V_{IN} = 3.2V$		0.65	
		$R_L = 8\Omega$, $V_{IN} = 5V$	0.8	1.1	
Output Current Limit		0.6	1	1.6	A
Gain Accuracy	$-9dB \leq Gain \leq 15dB$			± 0.13	dB
	Gain = 18dB			± 0.17	
Total Harmonic Distortion + Noise	$R_L = 8\Omega$, $f = 1kHz$, $P_{OUT} = 0.25W$, $V_{IN} = 3.2V$		0.004		%
Signal-to-Noise Ratio	$R_L = 8\Omega$, $f = 1kHz$, $P_{OUT} = 0.25W$, $V_{IN} = 3.2V$		104		dB
Maximum Capacitive Drive			500		pF
Power-Up from Shutdown Time, t_{UP}	See Figure 3		10		ms
Shutdown Time, t_{PD}	See Figure 3		3.5		μs

Note 1: Limits are 100% production tested at $T_A = +25^{\circ}C$. Limits over the operating temperature range are guaranteed by design.

Note 2: Dropout voltage is defined as the LED_ to GND (charge pump inactive) or LED_ to NEG (charge pump active) voltage at which current into LED_ drops 10% from the value at $V_{LED_} = 0.5V$.

Note 3: Output power is specified by a combination of a functional output current test and characterization analysis.

White LED Charge Pump with 1.1W Audio Amplifier

Typical Operating Characteristics

($V_{IN} = 3.2V$, $R_L = 8\Omega$, $T_A = +25^\circ C$, unless otherwise noted.)

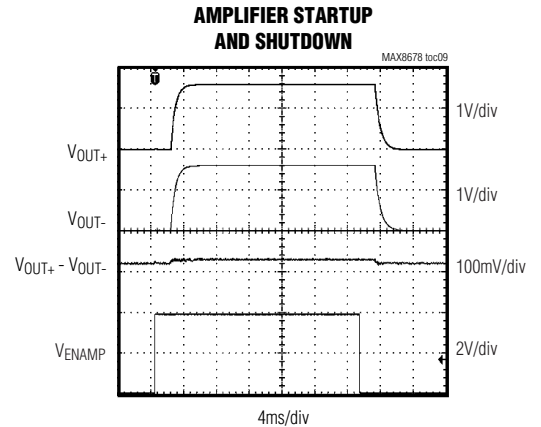
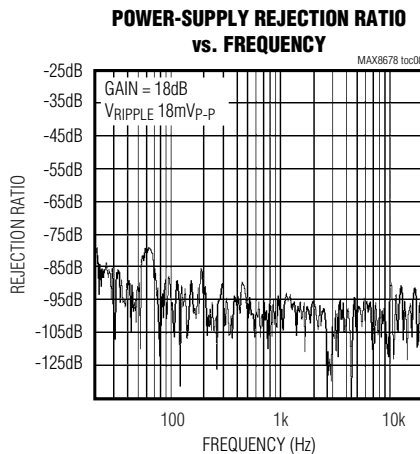
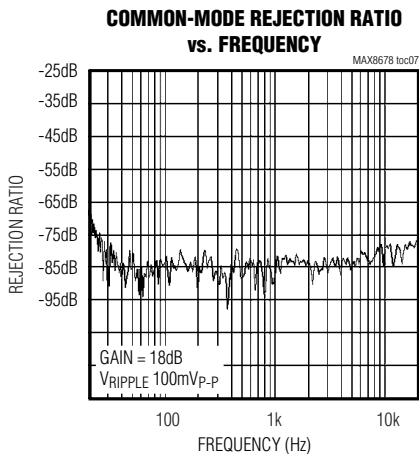
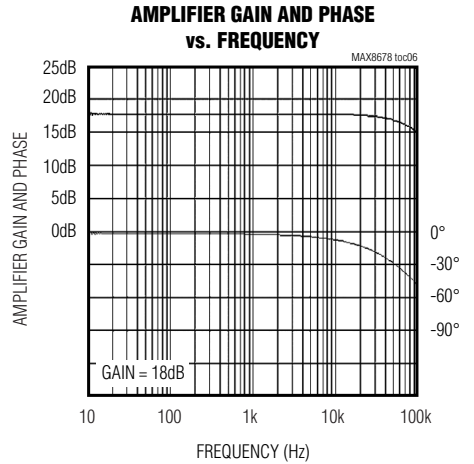
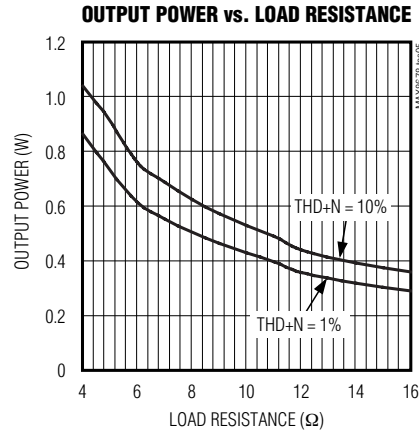
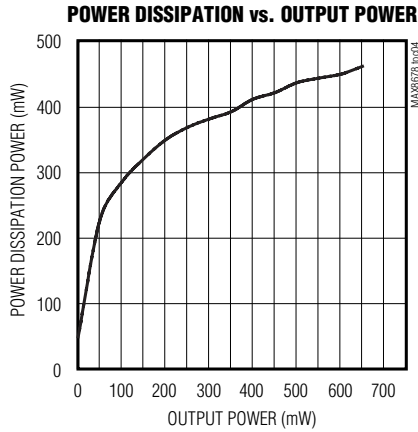
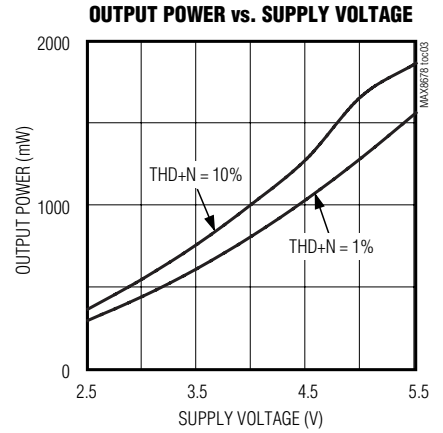
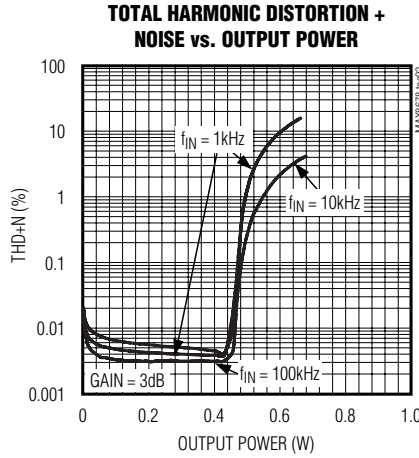
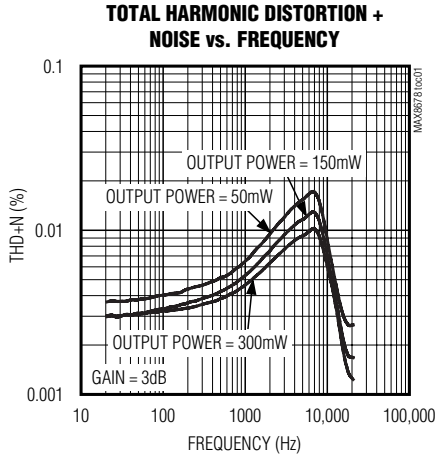

White LED Charge Pump with 1.1W Audio Amplifier

MAX8678

Typical Operating Characteristics (continued)

($V_{IN} = 3.2V$, $R_L = 8\Omega$, $T_A = +25^\circ C$, unless otherwise noted.)

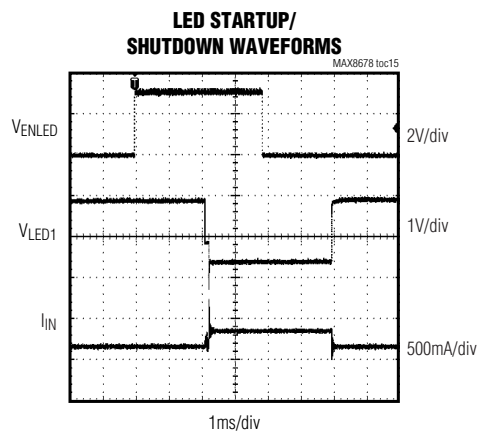
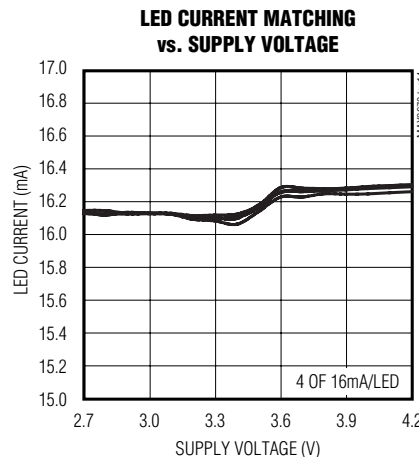
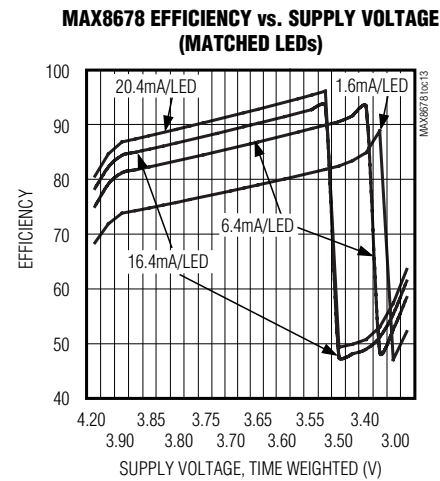
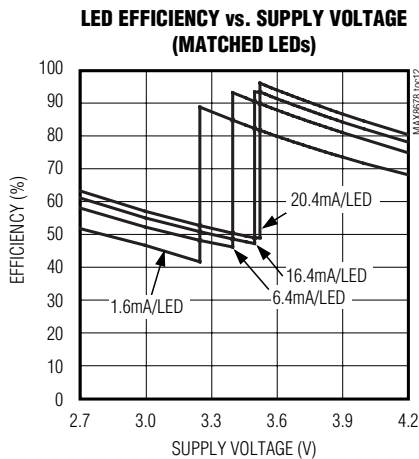
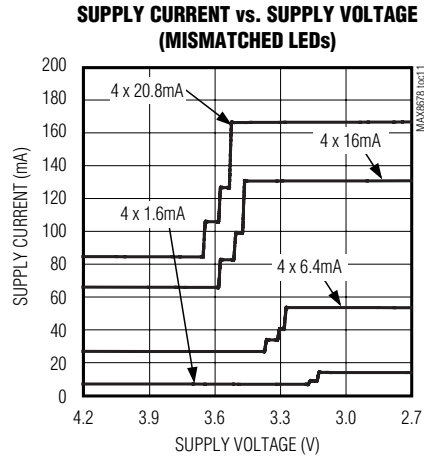
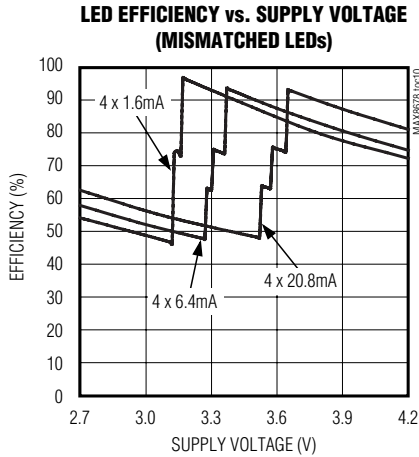

White LED Charge Pump with 1.1W Audio Amplifier

Typical Operating Characteristics (continued)

($V_{IN} = 3.2V$, $R_L = 8\Omega$, $T_A = +25^\circ C$, unless otherwise noted.)

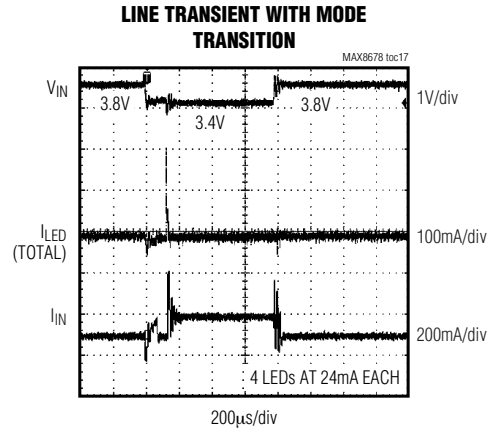
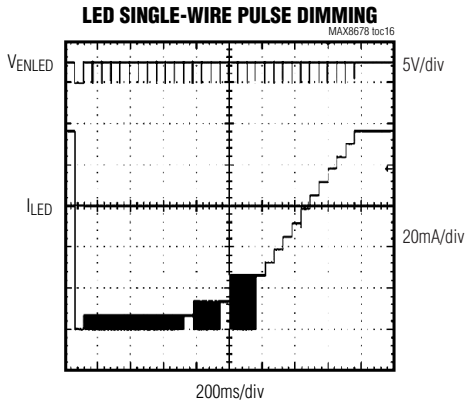

Pin Description

PIN	NAME	FUNCTION
1	IN	Analog Supply-Voltage Input. The input voltage range is 2.7V to 5.5V. Connect a 4.7μF ceramic capacitor from IN to GND as close as possible to the IC. IN is high impedance during shutdown.
2	GND	Ground. Connect GND to the system ground plane. Do not connect GND to the exposed paddle.
3	A+	Noninverting Differential Audio Input
4	A-	Inverting Differential Audio Input
5	ENAMP	Amplifier Enable and Gain Control. ENAMP is a serial-pulse interface logic input to control on/off and gain settings of the audio amplifier.
6	OUT+	Audio Amplifier Positive Output
7	OUT-	Audio Amplifier Negative Output
8	BIAS	DC Bias Bypass. Connect a 0.1μF ceramic capacitor from BIAS to GND as close as possible to the IC.
9–12	LED1–LED4	LED Current Regulators. Current flowing into LED_ is regulated to the current programmed by the serial-pulse interface. Connect LED_ to the cathodes of the corresponding external LEDs. LED_ is high impedance during shutdown. If unused, connect LED_ to IN to disable the regulator.
13	NEG	Charge-Pump Negative Output. Connect a 1μF ceramic capacitor from NEG to GND. In shutdown, an internal 10kΩ resistor pulls NEG to GND.
14	C-	Transfer Capacitor Negative Connection. Connect a 1μF ceramic capacitor from C+ to C-.
15	C+	Transfer Capacitor Positive Connection. Connect a 1μF ceramic capacitor from C+ to C-.
16	ENLED	LED Enable and Dimming Control. ENLED is a serial-pulse interface logic input to control on/off and dimming of the LED regulators.
—	EP	Exposed Paddle. Connect the exposed paddle to NEG directly under the IC.

White LED Charge Pump with 1.1W Audio Amplifier

MAX8678

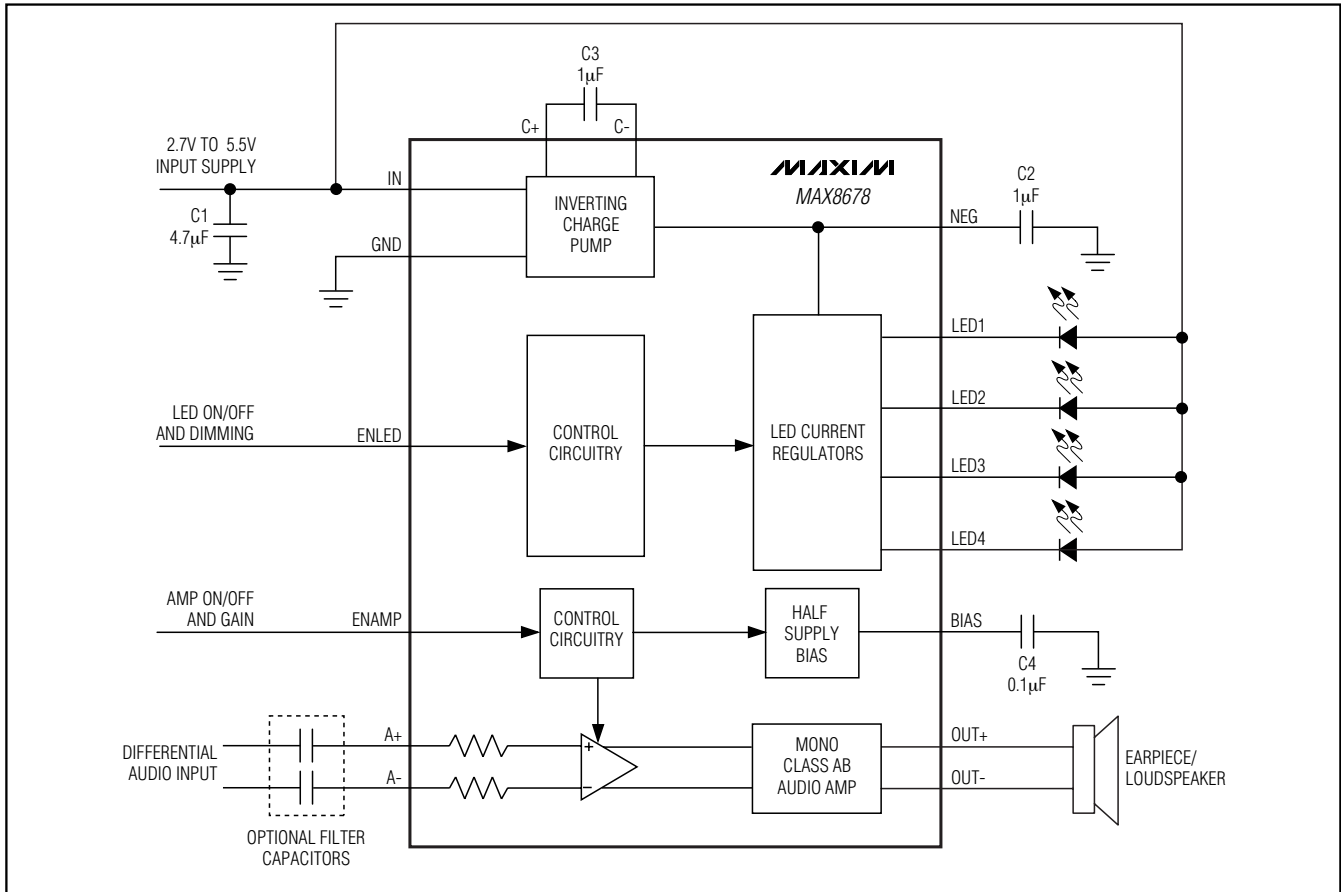

Figure 1. Functional Diagram

Detailed Description

The MAX8678 integrates a charge pump for white LEDs with an audio loudspeaker amplifier. The high-efficiency, adaptive charge pump drives up to four LEDs with constant current for uniform brightness for display back-lighting or camera flash. The LED current is adjustable from 0.1mA/LED to 24mA/LED in 31 pseudo-logarithmic steps through a single-wire serial-pulse interface. High accuracy and LED-to-LED current matching are maintained throughout the adjustment range. Figure 1 is the MAX8678 functional diagram.

The mono class AB audio amplifier directly drives an 8Ω loudspeaker with 1.1W RMS continuous power from a 5V supply with less than 1% THD+N. The gain is adjustable from -9dB to +18dB in ten 3dB steps through a single-wire serial-pulse interface. Clicks and pops are suppressed during on/off and all gain adjustments. Differential inputs improve common-mode noise rejection.

Shutdown

To reduce power consumption when not in use, the charge-pump LED driver and the audio amplifier have separate shutdown controls. To disable the LED driver, drive ENLED low for at least 3.2ms. To disable the audio amplifier, drive ENAMP low for at least 3.2ms. When both ENLED and ENAMP are held low, the IC supply current is reduced to about 0.1µA.

Thermal-Overload Protection

The thermal-overload protection circuitry monitors the temperature of the IC. When the die temperature reaches +160°C, the IC is shut down. The IC turns on after it has cooled by approximately 20°C. During continuous overload conditions, this results in a pulsed output.

White LED Charge Pump with 1.1W Audio Amplifier

LED Charge Pump

The charge pump drives up to four white LEDs with regulated constant current for displaying backlight applications. By utilizing an adaptive charge pump and extremely low-dropout current regulators, it achieves high efficiency over the full 1-cell lithium ion (Li+) battery input-voltage range. Fixed frequency of 1MHz switching allows for tiny external components. The regulation scheme is optimized to ensure low EMI and low input ripple.

Adaptive Charge-Pump Modes

When the supply voltage is sufficient to drive the LEDs, the charge pump is turned off to minimize the input supply current and the LED currents are linearly regulated. When the supply voltage is insufficient to drive the LEDs at the set current, the charge pump is enabled, creating a negative voltage at NEG and allowing the LED_ outputs to pull below ground to maintain the set LED current.

Low LED Current Levels

The MAX8678 internally generates a PWM signal to obtain higher resolution at lower currents. As the I_{LED} setting is below 6.4mA, the IC adjusts I_{LED} DC current, and the duty cycle is controlled by the PWM signal. The frequency of the PWM dimming signal is set at 1kHz with a minimum duty cycle of 1/16 to avoid the LED flicking effect to human eyes. Table 1 shows the current level and the corresponding duty cycle.

Soft-Start and Shutdown

The MAX8678 LED driver features a low-power shutdown mode for reduced current consumption. Hold ENLED low for 3.2ms to enter shutdown mode. This disables the charge pump and the LED current drivers.

When initially powering the MAX8678, or when starting up from shutdown mode, a soft-start feature prevents input current overshoot. See the startup waveforms in the *Typical Operating Characteristics* section.

Table 1. Internal PWM Duty Cycle vs. LED Set Current

I _{LED} (mA)	DUTY CYCLE (n/16)	I _{LED} (mA)	DUTY CYCLE (n/16)
6.4	16	1.2	12
5.6	14	1.0	10
4.8	12	0.8	8
4.0	10	0.7	7
3.2	16	0.6	6
2.8	14	0.5	5
2.4	12	0.4	4
2.0	10	0.3	3
1.6	16	0.2	2
1.4	14	0.1	1

Serial-Pulse Dimming Control (ENLED)

The MAX8678 includes a serial-pulse logic interface for on/off and dimming of the backlight. The dimming range is pseudo-logarithmic from 24mA to 0.1mA in 31 steps. Driving ENLED high turns on the IC and sets the internal register to 24.0mA. To dim the MAX8678, pulse ENLED low (500ns to 500µs pulse width). Each rising edge sets the LED current setting as shown in Table 2. Once the desired setting is reached, hold ENLED high for at least 3.2ms to set the internal register and the LED current changes. To set a new current level, repeat the previous sequence from the beginning.

To turn off the LEDs, hold ENLED low for at least 3.2ms. Figure 2 shows a timing diagram for ENLED.

If dimming control is not required, ENLED works as a simple on/off logic control. Drive ENLED high for at least 3.2ms to enable the LEDs, or drive ENLED low for at least 3.2ms for shutdown. The LED driver operates at 100% brightness under or OFF under these conditions.

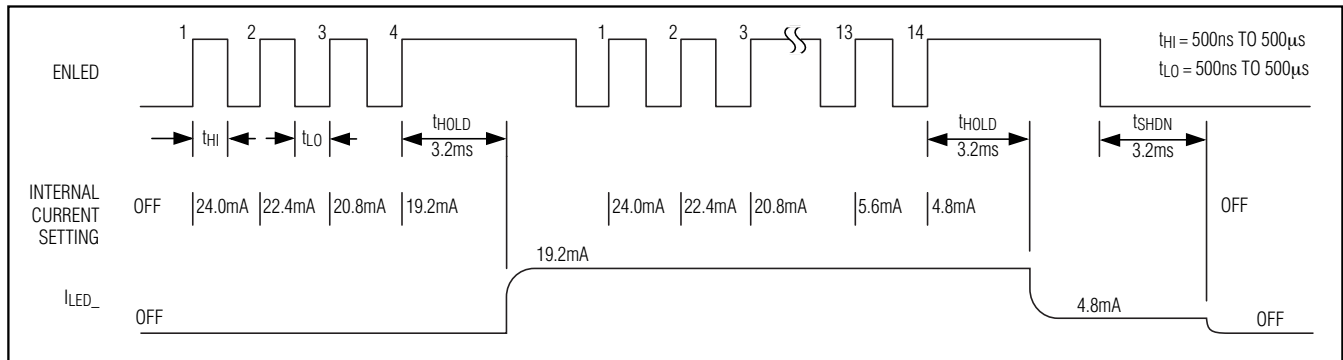

Figure 2. Serial-Pulse Dimming

White LED Charge Pump with 1.1W Audio Amplifier

Table 2. LED Current Levels

ENLED RISING EDGES	LED CURRENT (mA)	ENLED RISING EDGES	LED CURRENT (mA)
1	24.0	17	2.8
2	22.4	18	2.4
3	20.8	19	2.0
4	19.2	20	1.6
5	17.6	21	1.4
6	16.0	22	1.2
7	14.4	23	1.0
8	12.8	24	0.8
9	11.2	25	0.7
10	9.6	26	0.6
11	8.0	27	0.5
12	6.4	28	0.4
13	5.6	29	0.3
14	4.8	30	0.2
15	4.0	31	0.1
16	3.2	—	—

Open-Circuit and Short-Circuit Protection

The short-circuit protection detects when an LED is shorted and disables the corresponding current regulator to avoid wasting battery power. If any LED fails as an open circuit, the charge pump is forced on and the corresponding LED_ pin is internally connected to NEG.

Audio Amplifier

The MAX8678 contains a 1.1W RMS DirectDrive mono speaker amplifier. It features a low-power shutdown mode and click-and-pop suppression.

Bias

An internally generated common-mode BIAS voltage of $V_{IN} / 2$ sets the DC bias level for the audio outputs. The BIAS capacitor (C4 in Figure 1) improves PSRR and THD+N by reducing power supply and other noise sources at the common-mode bias node, and also generates the clickless/popless startup DC bias waveform for the speaker amplifier. A 0.1µF BIAS capacitor is recommended for most applications. Increasing C4 to 1µF slows turn-on and turn-off times by a factor of 10 and improves PSRR by 20dB (at 1kHz). Do not connect external loads to BIAS.

Shutdown Mode

The MAX8678 audio amplifier features a low-power shutdown mode for reduced current consumption. Hold ENAMP low for 3.2ms to shut down the audio amplifier. Entering shutdown disables the amplifier's bias circuitry, causes the audio outputs to go high impedance, and drives BIAS to GND.

Click-and-Pop Suppression

The MAX8678 features Maxim's industry-leading click-and-pop suppression circuitry. During startup, the amplifier common-mode bias voltage ramps to the DC bias point. When entering shutdown, the amplifier outputs are high impedance to 100kΩ between the outputs. This scheme minimizes the energy present in the audio band.

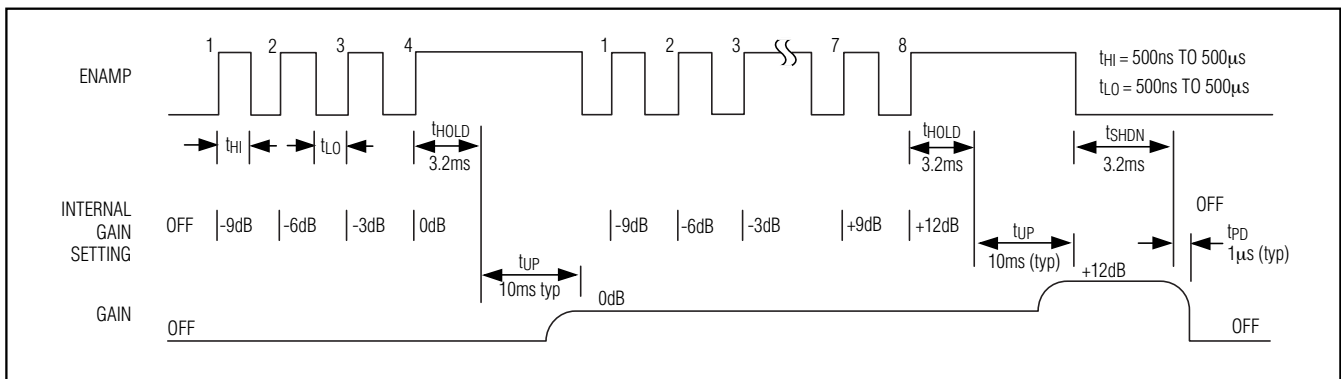

Figure 3. Serial-Pulse Gain Adjustment

White LED Charge Pump with 1.1W Audio Amplifier

Serial-Pulse Gain Adjustment (ENAMP)

The audio amplifier has an internal gain adjustment, controlled by a serial-pulse interface. The gain setting of the input amplifier is adjustable from -9dB to +18dB in 3dB steps. This allows the amplifier to be used for both hands-free and for receiver mode, without any external components.

Driving ENAMP high turns on the amplifier and sets the internal register to -9dB. Adjust the gain by pulsing ENAMP low (500ns to 500µs pulse width). Each rising edge sets the gain as shown in Table 3. Once the desired setting is reached, hold ENAMP high for at least 3.2ms to set the internal register and change the gain. To set a new current level, repeat the previous sequence from the beginning. To shut down the amplifier, hold ENAMP low for at least 3.2ms. Figure 3 is a timing diagram for ENAMP.

Table 3. Audio Amplifier-Input Impedance

ENAMP RISING EDGES	GAIN SETTING (dB)	R _{IN} (kΩ)		
		MIN	TYP	MAX
1	-9	69.1	99.0	140.0
2	-6	62.4	89.2	116.0
3	-3	54.9	78.4	102.0
4	0	46.8	66.9	87.0
5	3	38.8	55.5	72.1
6	6	31.3	44.7	58.1
7	9	24.6	35.1	45.6
8	12	18.8	26.9	35.0
9	15	14.1	20.2	26.2
10	18	10.5	15.0	19.5

Applications Information

BTL Amplifier

The MAX8678 is designed to drive a load differentially, a configuration referred to as bridge-tied load (BTL). The BTL configuration offers advantages over the single-ended configuration, where one side of the load is connected to ground. Driving the load differentially doubles the output voltage, thus quadrupling output power compared to a single-ended amplifier under similar configurations.

Since the differential outputs are biased at midsupply, there is no net DC voltage across the load. This eliminates the need for DC-blocking capacitors required for single-ended amplifiers. These capacitors can be large, expensive, consume board space, and degrade low-frequency performance.

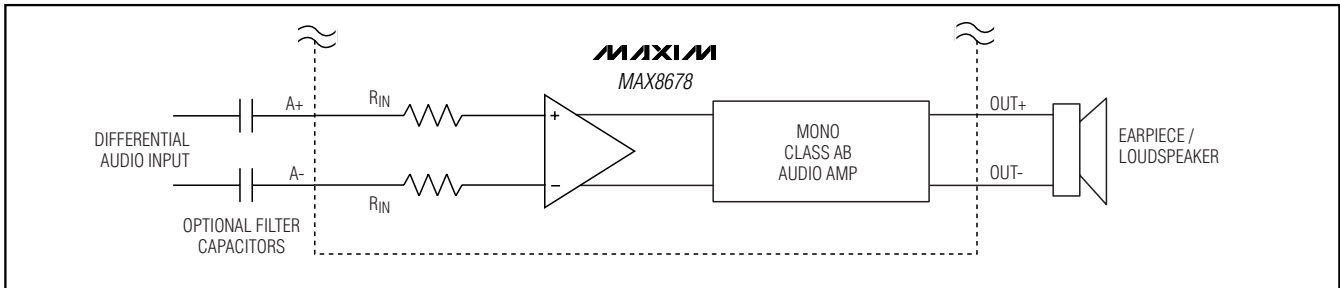

Figure 4. Differential Audio Input with Optional Filter Capacitors

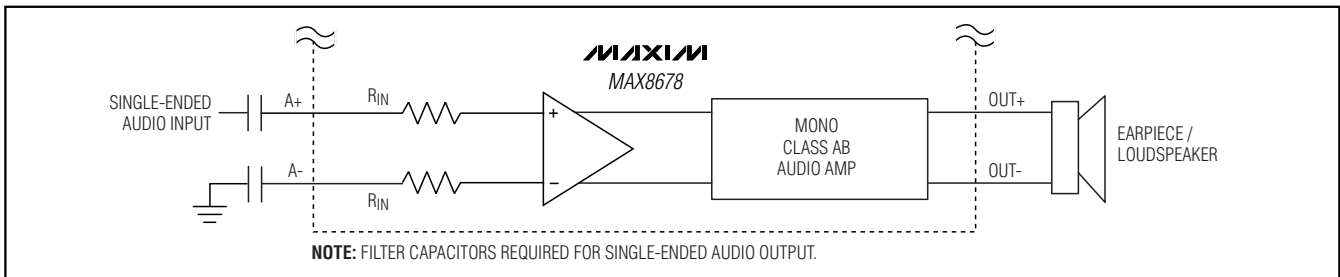

Figure 5. Single-Ended Audio Input

White LED Charge Pump with 1.1W Audio Amplifier

Input Filter

The fully differential amplifier inputs can be biased at voltages other than midsupply. The common-mode feedback circuit adjusts for input bias, ensuring the outputs are still biased at midsupply. Input capacitors are not required as long as the common-mode input voltage is within the specified range listed in the *Electrical Characteristics*.

If input capacitors are used (see Figure 4), the input capacitor in conjunction with the amplifier input impedance (R_{IN}) form a highpass filter that removes the DC bias from an incoming signal. The AC-coupling capacitor allows the amplifier to bias the signal to an optimum DC level. Assuming zero-source impedance, the -3dB point of the highpass filter is given by:

$$f_{-3dB} = \frac{1}{2\pi \times R_{IN} \times C_{IN}}$$

where R_{IN} is the input impedance given in Table 2.

Figure 5 shows a single-ended audio input.

Setting f_{-3dB} too high affects the low-frequency response of the amplifier. Use capacitors with dielectrics that have low-voltage coefficients, such as tantalum or aluminum electrolytic. Capacitors with high voltage coefficients, such as ceramics, can increase distortion at low frequencies.

PCB Layout

Good PC board (PCB) layout is essential for optimizing performance. Use large traces for the power-supply inputs and amplifier outputs to minimize losses due to parasitic trace resistance and to route heat away from the device. Good grounding improves audio performance and prevents any digital switching noise from coupling into the audio signal. The exposed paddle lowers the thermal resistance of the package by providing a direct-heat conduction path from the die to the PCB. Connect the exposed paddle to NEG directly under the IC. Refer to the MAX8678 Evaluation Kit for a good PCB layout example.

Chip Information

PROCESS: BiCMOS

White LED Charge Pump with 1.1W Audio Amplifier

Package Information

(The package drawing(s) in this data sheet may not reflect the most current specifications. For the latest package outline information go to www.maxim-ic.com/packages.)

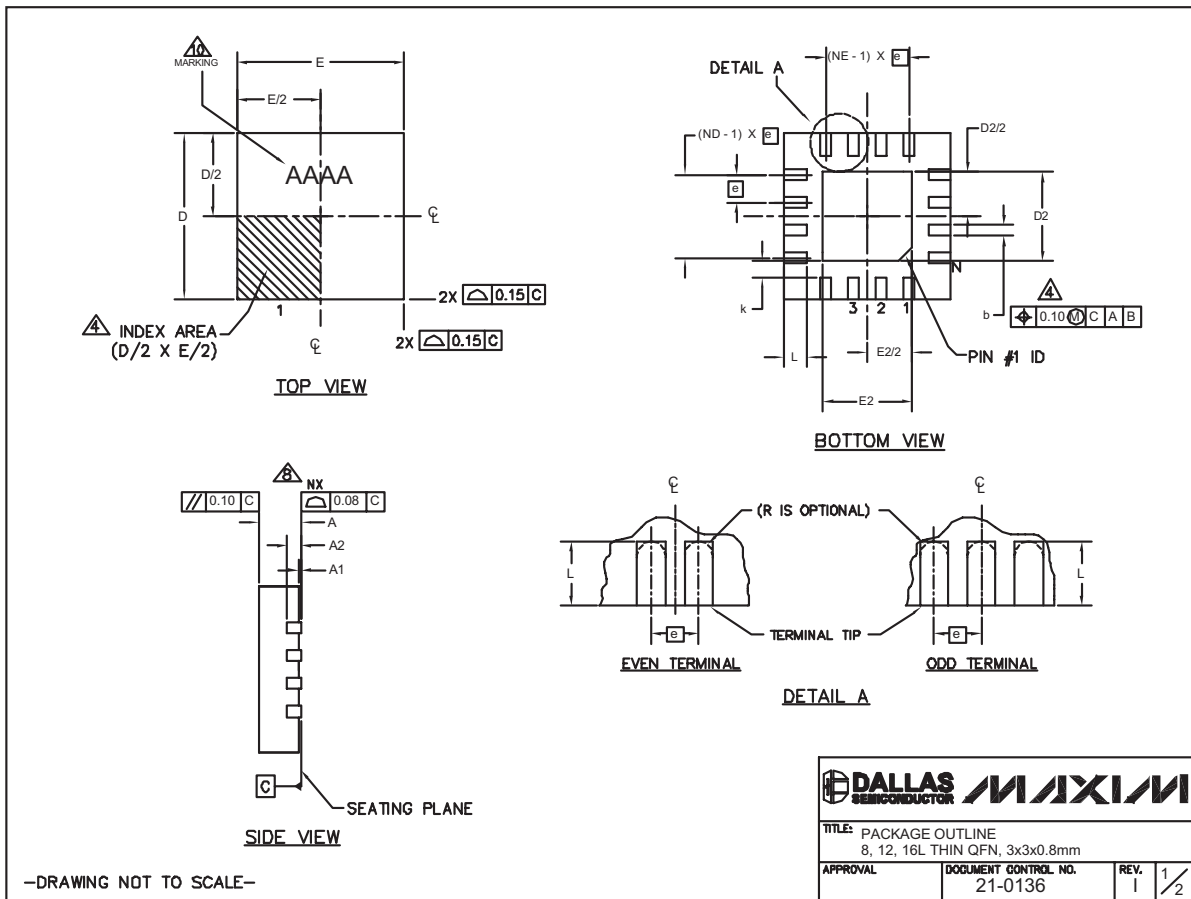

White LED Charge Pump with 1.1W Audio Amplifier

MAX8678

Package Information (continued)

(The package drawing(s) in this data sheet may not reflect the most current specifications. For the latest package outline information go to www.maxim-ic.com/packages.)

PKG	8L 3x3			12L 3x3			16L 3x3		
REF.	MIN.	NOM.	MAX.	MIN.	NOM.	MAX.	MIN.	NOM.	MAX.
A	0.70	0.75	0.80	0.70	0.75	0.80	0.70	0.75	0.80
b	0.25	0.30	0.35	0.20	0.25	0.30	0.20	0.25	0.30
D	2.90	3.00	3.10	2.90	3.00	3.10	2.90	3.00	3.10
E	2.90	3.00	3.10	2.90	3.00	3.10	2.90	3.00	3.10
e	0.65 BSC.			0.50 BSC.			0.50 BSC.		
L	0.35	0.55	0.75	0.45	0.55	0.65	0.30	0.40	0.50
N	8			12			16		
ND	2			3			4		
NE	2			3			4		
A1	0	0.02	0.05	0	0.02	0.05	0	0.02	0.05
A2	0.20 REF			0.20 REF			0.20 REF		
k	0.25	-	-	0.25	-	-	0.25	-	-

EXPOSED PAD VARIATIONS									
PKG CODES	D2			E2			PIN ID	JEDEC	
	MIN.	NOM.	MAX.	MIN.	NOM.	MAX.			
TQ833-1	0.25	0.70	1.25	0.25	0.70	1.25	0.35 x 45°	WEEC	
T1233-1	0.95	1.10	1.25	0.95	1.10	1.25	0.35 x 45°	WEED-1	
T1233-3	0.95	1.10	1.25	0.95	1.10	1.25	0.35 x 45°	WEED-1	
T1233-4	0.95	1.10	1.25	0.95	1.10	1.25	0.35 x 45°	WEED-1	
T1633-2	0.95	1.10	1.25	0.95	1.10	1.25	0.35 x 45°	WEED-2	
T1633F-3	0.65	0.80	0.95	0.65	0.80	0.95	0.225 x 45°	WEED-2	
T1633FH-3	0.65	0.80	0.95	0.65	0.80	0.95	0.225 x 45°	WEED-2	
T1633-4	0.95	1.10	1.25	0.95	1.10	1.25	0.35 x 45°	WEED-2	
T1633-5	0.95	1.10	1.25	0.95	1.10	1.25	0.35 x 45°	WEED-2	

NOTES:

- DIMENSIONING & TOLERANCING CONFORM TO ASME Y14.5M-1994.
- ALL DIMENSIONS ARE IN MILLIMETERS. ANGLES ARE IN DEGREES.
- N IS THE TOTAL NUMBER OF TERMINALS.
- THE TERMINAL #1 IDENTIFIER AND TERMINAL NUMBERING CONVENTION SHALL CONFORM TO JESD 95-1 SPP-012. DETAILS OF TERMINAL #1 IDENTIFIER ARE OPTIONAL, BUT MUST BE LOCATED WITHIN THE ZONE INDICATED. THE TERMINAL #1 IDENTIFIER MAY BE EITHER A MOLD OR MARKED FEATURE.
- DIMENSION b APPLIES TO METALLIZED TERMINAL AND IS MEASURED BETWEEN 0.20 mm AND 0.25 mm FROM TERMINAL TIP.
- ND AND NE REFER TO THE NUMBER OF TERMINALS ON EACH D AND E SIDE RESPECTIVELY.
- DEPOPULATION IS POSSIBLE IN A SYMMETRICAL FASHION.
- COPLANARITY APPLIES TO THE EXPOSED HEAT SINK SLUG AS WELL AS THE TERMINALS.
- DRAWING CONFORMS TO JEDEC MO220 REVISION C.
- MARKING IS FOR PACKAGE ORIENTATION REFERENCE ONLY.
- NUMBER OF LEADS SHOWN ARE FOR REFERENCE ONLY.
- WARPAGE NOT TO EXCEED 0.10mm.

—DRAWING NOT TO SCALE—

		
TITLE: PACKAGE OUTLINE 8, 12, 16L THIN QFN, 3x3x0.8mm		
APPROVAL	DOCUMENT CONTROL NO. 21-0136	REV. 1 $\frac{2}{2}$

Maxim cannot assume responsibility for use of any circuitry other than circuitry entirely embodied in a Maxim product. No circuit patent licenses are implied. Maxim reserves the right to change the circuitry and specifications without notice at any time.

Maxim Integrated Products, 120 San Gabriel Drive, Sunnyvale, CA 94086 408-737-7600 _____ 13

Looking for pricing, stock, or lifecycle information?

Click below to explore more details on WIN SOURCE:

 [View MAX8678ETE+T on WIN SOURCE](#)

 [Maxim Integrated](#) Information

Optimize Your Supply Chain with WIN SOURCE Solutions

-  Global Sourcing Solution
-  Obsolete Management
-  Cost Control Management
-  Shortage Management
-  Alternative Solution
-  Excess Inventory Management