



THE DATASHEET OF MAX8595XETA



EVALUATION KIT
AVAILABLE



High-Efficiency, 36V Step-Up Converters with T_A Derating Option for 2 to 9 White LEDs

General Description

The MAX8595X/MAX8596X drive up to nine white LEDs with constant current and high efficiency to provide LCD backlighting in cell phones, PDAs, and other handheld devices. The series connection allows the LED currents to be identical for uniform brightness and minimizes the number of traces to the LEDs. The MAX8595X regulates constant LED current over the entire temperature range. The MAX8596X features an ambient-temperature derating function to avoid overdriving the white LEDs during high ambient temperatures, enabling higher drive current below +42°C.

A single Dual Mode™ input provides a simple means of brightness adjustment and on/off control. Fast 1MHz current-mode PWM operation allows for small input and output capacitors and a small inductor while minimizing ripple on the input supply/battery. Soft-start eliminates inrush current during startup.

The MAX8595X/MAX8596X are available in a space-saving, 8-pin, 3mm x 3mm TDFN package.

Applications

Cell Phones and Smart Phones
PDAs, Palmtops, and Wireless Handhelds
e-Books and Subnotebooks
White LED Display Backlighting

Dual Mode is a trademark of Maxim Integrated Products, Inc.

Typical Operating Circuit

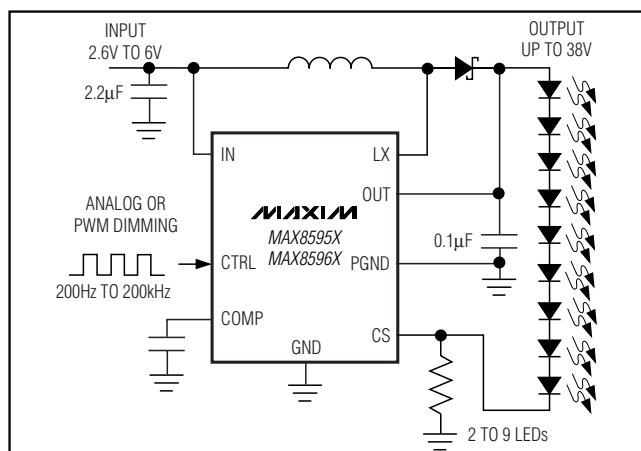

Features

- ◆ Up to Nine LEDs at 25mA
- ◆ Temperature Derating Function to Allow Fewer LEDs for Same Light (MAX8596X)
- ◆ 86% Efficiency (PLEDs / PIN)
- ◆ 1.7% Current-Regulation Accuracy
- ◆ Output Overvoltage Protection
- ◆ Flexible Dimming Control
 - Analog
 - Direct-PWM Internal Filter
- ◆ 1MHz PWM Switching Frequency
- ◆ 0.1µF Output Capacitor
- ◆ 12mVp-p Low Input Ripple
- ◆ Soft-Start Eliminates Inrush Current
- ◆ 2.6V to 6V Input Range
- ◆ 0.3µA Shutdown Current
- ◆ Pin Compatible with the MAX1561 and MAX1599
- ◆ TDFN 3mm x 3mm x 0.8mm Package with Exposed Paddle

Ordering Information

PART	TEMP RANGE	PIN-PACKAGE	PKG CODE
MAX8595XETA-T	-40°C to +85°C	8 TDFN-EP*	T833-1
MAX8595XETA+T	-40°C to +85°C	8 TDFN-EP*	T833-1
MAX8596XETA-T	-40°C to +85°C	8 TDFN-EP*	T833-1
MAX8596XETA+T	-40°C to +85°C	8 TDFN-EP*	T833-1

+Denotes lead-free package.

T = Tape and reel.

*EP = Exposed paddle.

Pin Configuration

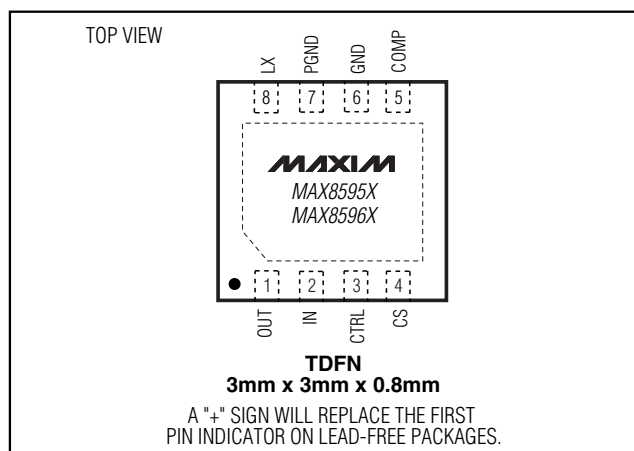

Maxim Integrated Products 1

For pricing, delivery, and ordering information, please contact Maxim/Dallas Direct! at 1-888-629-4642, or visit Maxim's website at www.maxim-ic.com.

MAX8595X/MAX8596X

High-Efficiency, 36V Step-Up Converters with T_A Derating Option for 2 to 9 White LEDs

ABSOLUTE MAXIMUM RATINGS

IN to GND	-0.3V to +7V	CS to GND	-0.3V to ($V_{IN} + 1.2V$)
PGND to GND	-0.3V to +0.3V	Continuous Power Dissipation ($T_A = +70^\circ C$)	
LX, OUT to GND	-0.3V to +40V	8-Pin TDFN 3mm x 3mm	
CTRL to GND.....	-0.3V to the lower of +6V or ($V_{IN} + 2V$)	(derate 24.4mW/ $^\circ C$ above +70 $^\circ C$).....	1950mW
COMP	-0.3V to ($V_{IN} + 0.3V$)	Operating Temperature Range	-40 $^\circ C$ to +85 $^\circ C$
I _{LX}	1.0A _{RMS}	Junction Temperature.....	+150 $^\circ C$
I _{CS}	25mA ($V_{CS} < V_{IN} + 1.2V$)	Storage Temperature Range.....	-65 $^\circ C$ to +150 $^\circ C$
		Lead Temperature (soldering, 10s).....	+300 $^\circ C$

Stresses beyond those listed under "Absolute Maximum Ratings" may cause permanent damage to the device. These are stress ratings only, and functional operation of the device at these or any other conditions beyond those indicated in the operational sections of the specifications is not implied. Exposure to absolute maximum rating conditions for extended periods may affect device reliability.

ELECTRICAL CHARACTERISTICS

($V_{IN} = 3.0V$, $L = 22\mu H$, $C_{IN} = 2.2\mu F$, $C_{OUT} = 0.1\mu F$, $C_{COMP} = 0.1\mu F$, $R_{SENSE} = 13\Omega$, $V_{CTRL} = 1.5V$, $T_A = -40^\circ C$ to +85 $^\circ C$, unless otherwise noted. Typical values are at $T_A = +25^\circ C$.) (Note 1)

PARAMETER	CONDITIONS		MIN	TYP	MAX	UNITS
Supply Voltage			2.6		6.0	V
UVLO Threshold	V_{IN} rising or falling		2.10	2.38	2.55	V
UVLO Hysteresis				30		mV
Quiescent Current	No switching			0.5	0.7	mA
Shutdown Supply Current	CTRL = GND, $V_{OUT} = V_{IN}$	$T_A = +25^\circ C$		0.3	2	μA
		$T_A = +85^\circ C$		1		
OVLO Threshold	V_{OUT} rising		36	38	40	V
OVLO Hysteresis				2		V
OUT Input Bias Current	$V_{OUT} = 32V$, $V_{CTRL} > 0.24V$		9	20	35	μA
	OUT = IN, CTRL = GND	$T_A = +25^\circ C$		0.01	1	
		$T_A = +85^\circ C$		0.1		
Output Voltage Range	(Note 2)		$V_{IN} - V_D$		36	V
ERROR AMPLIFIER						
CTRL to CS Regulation	$V_{CTRL} = 1.50V$, $V_{IN} = 2.6V$ to 5.5V	$T_A = +25^\circ C$	0.295	0.300	0.305	V
		$T_A = 0^\circ C$ to +85 $^\circ C$	0.292	0.300	0.308	
		$T_A = -40^\circ C$ to +85 $^\circ C$	0.290	0.300	0.310	
CS Input Bias Current	$V_{CS} = V_{CTRL} / 5$	$T_A = +25^\circ C$		0.01	1	μA
		$T_A = +85^\circ C$		0.03		
CS Maximum Brightness Clamp Voltage	MAX8595X, $V_{CTRL} = 3.0V$		310	330	347	mV
	MAX8596X, $V_{CTRL} = 3.0V$	$T_A = -40^\circ C$ to +25 $^\circ C$	330	345	360	
		$T_A = +42^\circ C$		343		
		$T_A = +85^\circ C$		106.5		
CTRL Voltage for CS Maximum Brightness Clamp	MAX8595Z			1.65		V
	MAX8596Z			1.72		
CS Derating Function Start Temperature	MAX8596Z, $V_{CTRL} = 3.0V$			+42		$^\circ C$

High-Efficiency, 36V Step-Up Converters with T_A Derating Option for 2 to 9 White LEDs

MAX8595X/MAX8596X

ELECTRICAL CHARACTERISTICS (continued)

($V_{IN} = 3.0V$, $L = 22\mu H$, $C_{IN} = 2.2\mu F$, $C_{OUT} = 0.1\mu F$, $C_{COMP} = 0.1\mu F$, $R_{SENSE} = 13\Omega$, $V_{CTRL} = 1.5V$, $T_A = -40^\circ C$ to $+85^\circ C$, unless otherwise noted. Typical values are at $T_A = +25^\circ C$.) (Note 1)

PARAMETER	CONDITIONS	MIN	TYP	MAX	UNITS
CS Derating Function Slope	MAX8596X, $V_{CTRL} = 3.0V$, $T_A = +42^\circ C$ to $+85^\circ C$		-5.5		mV/ $^\circ C$
CTRL Input Resistance	$V_{CTRL} \leq 1.5V$	250	500	780	k Ω
CTRL Dual-Mode Threshold		100	170	240	mV
CTRL Dual-Mode Hysteresis			5		mV
CTRL Shutdown Enable Delay	(Note 3)	6.0	8.2	10.5	ms
CS to COMP Transconductance	$V_{COMP} = 1.5V$	32	50	82	μS
COMP Input Resistance to Ground	In shutdown, UVLO or OVLO		20		k Ω
OSCILLATOR					
Operating Frequency		0.75	1.0	1.25	MHz
Minimum Duty Cycle	PWM mode		12		%
	Pulse skipping		0		
Maximum Duty Cycle	CTRL = IN, CS = GND	94	95		%
n-CHANNEL SWITCH					
LX On-Resistance	$I_{LX} = 190mA$		0.8	1.35	Ω
LX Leakage Current	$V_{LX} = 36V$, CTRL = GND	$T_A = +25^\circ C$	0.01	5	μA
		$T_A = +85^\circ C$	1		
LX Current Limit	Duty cycle = 90%	500	700	900	mA

Note 1: Parameters are 100% production tested at $T_A = +25^\circ C$. Limits over the operating temperature range are regulated by design and characterization.

Note 2: V_D is the forward-voltage drop of the Schottky diode in Figure 1.

Note 3: Time from CTRL going below the Dual-Mode threshold to IC shutdown.

High-Efficiency, 36V Step-Up Converters with T_A Derating Option for 2 to 9 White LEDs

Typical Operating Characteristics

(Circuit of Figure 1, $V_{IN} = 3.6V$, $I_{LED} = 25mA$, $L = 22\mu H$, $C_{IN} = 2.2\mu F$, $C_{OUT} = 0.1\mu F$, $C_{COMP} = 0.1\mu F$, $R_{SENSE} = 13\Omega$, 4 LEDs, $T_A = +25^\circ C$, unless otherwise noted.)

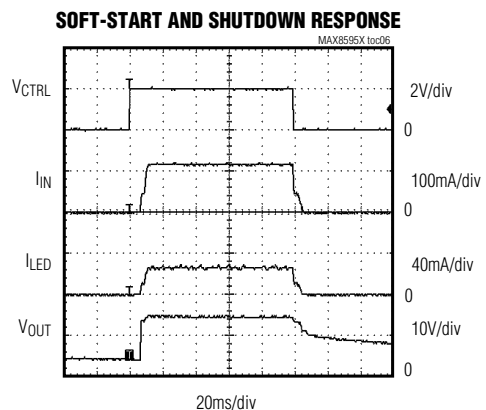
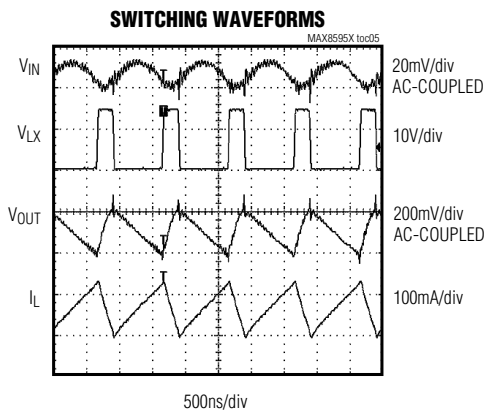
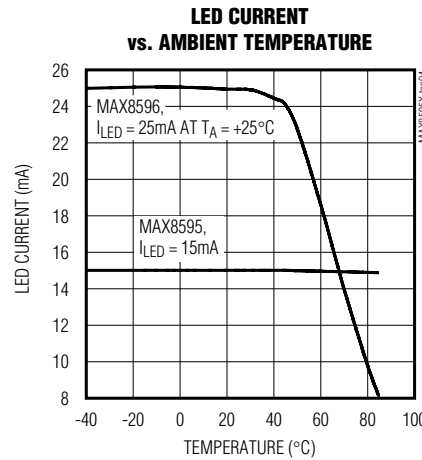
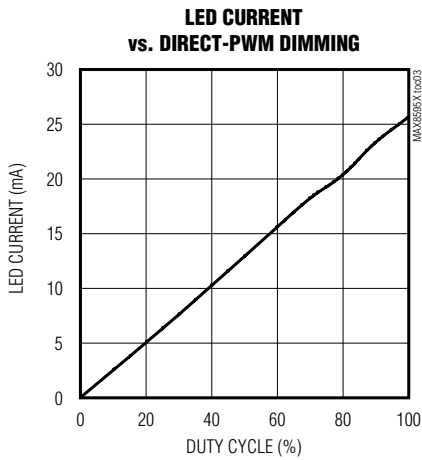
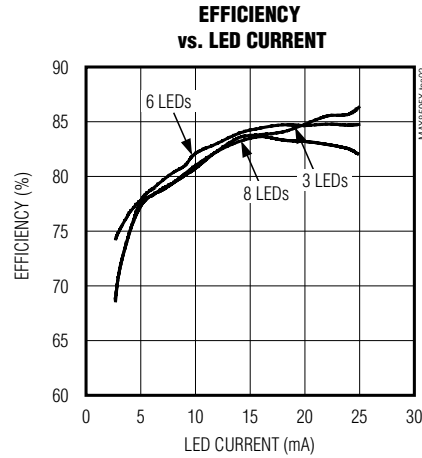
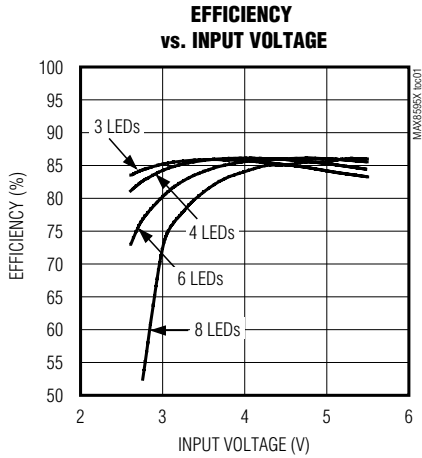

High-Efficiency, 36V Step-Up Converters with T_A Derating Option for 2 to 9 White LEDs

Typical Operating Characteristics (continued)

(Circuit of Figure 1, $V_{IN} = 3.6V$, $I_{LED} = 25mA$, $L = 22\mu H$, $C_{IN} = 2.2\mu F$, $C_{OUT} = 0.1\mu F$, $C_{COMP} = 0.1\mu F$, $R_{SENSE} = 13\Omega$, 4 LEDs, $T_A = +25^\circ C$, unless otherwise noted.)

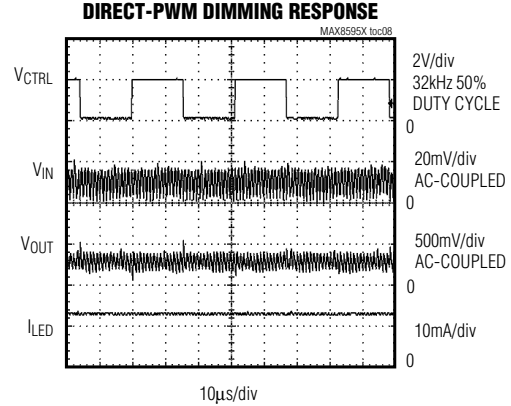
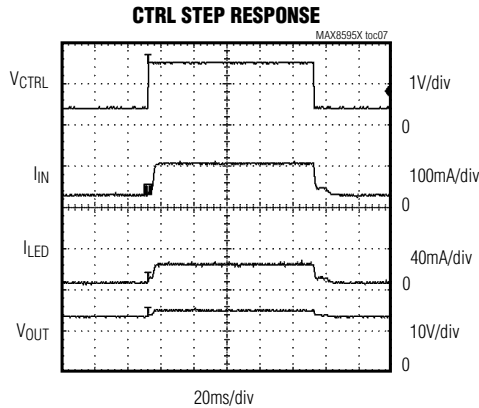

MAX8595X/MAX8596X

Pin Description

PIN	NAME	FUNCTION
1	OUT	Overvoltage Sense. When V_{OUT} is greater than 38V (typ), the internal n-channel MOSFET turns off until V_{OUT} drops below 36V (typ), then the IC reenters soft-start. Connect a 0.1 μF ceramic capacitor from OUT to ground. In shutdown, V_{OUT} is one diode drop below V_{IN} .
2	IN	Input Voltage Supply. The input voltage range is 2.6V to 6.0V. Connect a 2.2 μF ceramic capacitor from IN to GND.
3	CTRL	Brightness Control Input. The voltage applied to CTRL controls LED brightness. Varying the voltage from 0.24V to 1.65V (1.72V for the MAX8596X) adjusts the brightness from dim to 100% brightness, respectively. Any voltage above 1.65V (1.72V) does not increase brightness. Hold CTRL below 100mV to shut down the IC after an 8.2ms delay.
4	CS	Current-Sense Feedback Input. Connect a resistor from CS to GND to set the LED bias current. The voltage at CS regulates to $V_{CTRL} / 5$ or 0.330V (0.343V for the MAX8596X), whichever is lower.
5	COMP	Compensation Input. Connect a 0.1 μF ceramic capacitor (C_{COMP}) from COMP to GND. C_{COMP} stabilizes the converter, controls soft-start, and lowpass filters direct PWM dimming at CTRL. C_{COMP} discharges to 0V through an internal 20k Ω resistor in shutdown.
6	GND	Ground. Connect to PGND and the exposed pad directly under the IC.
7	PGND	Power Ground. Connect to GND and the exposed pad directly under the IC.
8	LX	Inductor Connection. Connect LX to the node between the inductor and the Schottky diode. LX is high impedance in shutdown.
—	EP	Exposed Pad. Connect to a large ground plane for maximum package heat dissipation. Connect directly to GND and PGND under the IC.

High-Efficiency, 36V Step-Up Converters with T_A Derating Option for 2 to 9 White LEDs

Detailed Description

The high efficiency and small size of the MAX8595X/MAX8596X make them ideally suited to drive up to nine series-connected LEDs. These devices operate as a boost DC-DC converter that regulates output current rather than voltage. The MAX8595X/MAX8596X provide even illumination by sourcing the same output current through each LED, eliminating the need for expensive factory calibration. The fast 1MHz internal oscillator allows for a small inductor and small input and output capacitors while minimizing input and output ripple.

The single analog control input (CTRL) allows easy adjustment of LED brightness and on/off control. This allows simple logic-level on/off control, analog voltage control, or PWM duty-cycle control of both brightness and shutdown. In shutdown, supply current is reduced to a low 0.3 μ A (typ). A soft-start gradually illuminates the LEDs, eliminating the inrush current during startup.

The MAX8596X has the additional feature of derating LED current as ambient temperature rises. Above +42°C, the CS regulation voltage is reduced at a rate of 5.5mV/°C, thus reducing the LED current.

Soft-Start

The MAX8595X/MAX8596X attain soft-start by charging C_{COMP} gradually with a current source. When V_{COMP} rises above 1.25V, the internal MOSFET begins switching at a reduced duty cycle. When V_{COMP} rises above 2.25V, the duty cycle is at its maximum. See the *Typical Operating Characteristics* for an example of soft-start operation.

Shutdown

The MAX8595X/MAX8596X enter shutdown when V_{CTRL} is less than 100mV for more than 8.2ms. In shutdown, supply current is reduced to 0.3 μ A (typ) by powering down the entire IC except for the CTRL voltage-detection circuitry. C_{COMP} is discharged during shutdown, allowing the device to reinitiate soft-start when it is enabled. Although the internal n-channel MOSFET does not switch in shutdown, there is still a DC current path between the input and the LEDs through the inductor and Schottky diode. The minimum forward voltage of the LED array must exceed the maximum input voltage to ensure that the LEDs remain off in shutdown. However, with two or more LEDs, the forward voltage is large enough to keep leakage current low, less than 1 μ A (typ). Typical shutdown timing characteristics are shown in the *Typical Operating Characteristics*.

Overvoltage Protection

Overvoltage lockout (OVLO) occurs when V_{OUT} is above 38V (typ). The protection circuitry stops the inter-

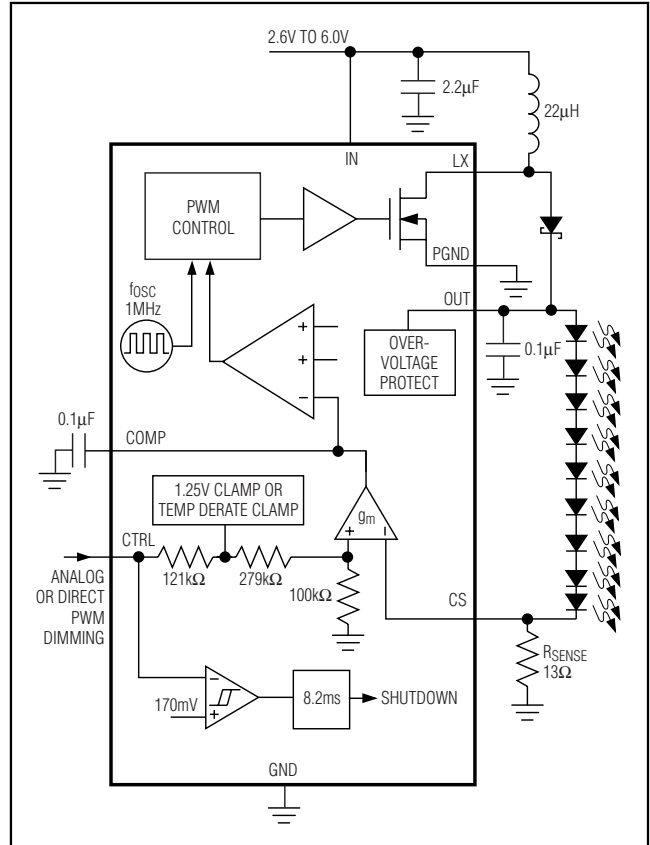

Figure 1. Functional Diagram and Typical Application Circuit

nal MOSFET from switching and causes V_{COMP} to decay towards 0V. The device comes out of OVLO and into soft-start when V_{OUT} falls below 36V (typ).

Ambient Temperature Derating Function (MAX8596X)

The MAX8596X limits the maximum LED current depending on the die temperature. V_{CS} is limited to 343mV up to +42°C. Once the temperature reaches +42°C, the maximum V_{CS} declines by 5.5mV/°C until the minimum 106.5mV threshold is reached at +85°C. Due to the package's exposed paddle, the die temperature is always very close to the PC board temperature.

The temperature derating function allows the LED current to be safely set higher at normal operating temperatures, thereby allowing either a brighter display or fewer LEDs to be used for normal display brightness. See the *Typical Operating Characteristics* for LED Current vs. Ambient Temperature.

High-Efficiency, 36V Step-Up Converters with T_A Derating Option for 2 to 9 White LEDs

Design Procedure

Adjusting LED Current

Adjusting the output current of the MAX8595X/MAX8596X changes the brightness of the LEDs. An analog input (CTRL) and the sense-resistor value set the output current. Output current is given by:

$$I_{LED} = V_{CTRL} / (5 \times R_{SENSE})$$

The V_{CTRL} voltage range for adjusting output current is 0.24V to 1.65V (or 1.72V for the MAX8596X). To set the maximum current, calculate R_{SENSE} when V_{CTRL} is at its maximum as follows:

$$\text{For the MAX8595X, } R_{SENSE} = 1.65 / (5 \times I_{LED(MAX)})$$

$$\text{For the MAX8596X, } R_{SENSE} = 1.72 / (5 \times I_{LED(MAX)})$$

Power dissipation in R_{SENSE} is typically less than 10mW, allowing the use of a small surface-mount resistor.

PWM Dimming Control

CTRL is also used as a digital input allowing LED brightness control with a logic-level PWM signal applied directly to CTRL. The frequency range is from 200Hz to 200kHz, while 0% duty cycle corresponds to zero current and 100% duty cycle corresponds to full current. The error amplifier and compensation capacitor form a lowpass filter so PWM dimming results in DC current to the LEDs without the need for any additional RC filters; see the *Typical Operating Characteristics*.

Capacitor Selection

Ceramic capacitors with X5R, X7R, or better dielectric are recommended for stable operation over the entire operating temperature range. The exact values of input and output capacitors are not critical. The typical value for the input capacitor is 2.2 μ F, and the typical value for the output capacitor is 0.1 μ F. Higher value capacitors can be used to reduce input and output ripple, but at the expense of size and higher cost. C_{COMP} stabilizes the converter and controls soft-start. Connect a 0.1 μ F capacitor from COMP to GND. For stable operation, C_{OUT} must not exceed 10 times C_{COMP} .

Inductor Selection

Inductor values range from 10 μ H to 47 μ H. A 22 μ H inductor optimizes the efficiency for most applications while maintaining low 12mV_{p-p} input ripple. With input

voltages near 5V, a larger value of inductance can be more efficient. To prevent core saturation, ensure that the inductor-saturation current rating exceeds the peak inductor current for the application. Calculate the peak inductor current with the following formula:

$$I_{PEAK} = \frac{V_{OUT(MAX)} \times I_{LED(MAX)}}{0.9 \times V_{IN(MIN)}} + \frac{V_{IN(MIN)} \times 0.9\mu s}{2 \times L}$$

Schottky Diode Selection

The high switching frequency of the MAX8595X/MAX8596X demands a high-speed rectification diode (D1) for optimum efficiency. A Schottky diode is recommended due to its fast recovery time and low forward-voltage drop. Ensure that the diode's average and peak current rating exceed the average output current and peak inductor current. In addition, the diode's reverse breakdown voltage must exceed V_{OUT} . The RMS diode current can be approximated from:

$$I_{DIODE(RMS)} = \sqrt{I_{OUT} \times I_{PEAK}}$$

Applications Information

Compensation Information

The dominant pole (f_{DP}) of the error amplifier is given by:

$$f_{DP} = \frac{1}{4M\Omega \times C_{COMP}}$$

The output pole is given by

$$f_{OUT} = \frac{1}{2\pi \times R_{OUT} \times C_{OUT}}$$

where R_{OUT} is the sum of R_{SENSE} and the incremental series resistance of the white LED string.

Continuous conduction introduces a right-half-plane zero determined by

$$f_{RHPZ} = \left(\frac{V_{IN}}{V_{OUT}} \right) \times \frac{R_{OUT}}{2\pi \times L}$$

High-Efficiency, 36V Step-Up Converters with T_A Derating Option for 2 to 9 White LEDs

In applications using large R_{SENSE} , it may be necessary to add a series resistor (R_{COMP}) to C_{COMP} to increase control loop phase margin. See Figure 2 for details.

The frequency of the zero is given by:

$$f_z = \frac{1}{2\pi \times R_{COMP} \times C_{COMP}}$$

Consult the factory for further information.

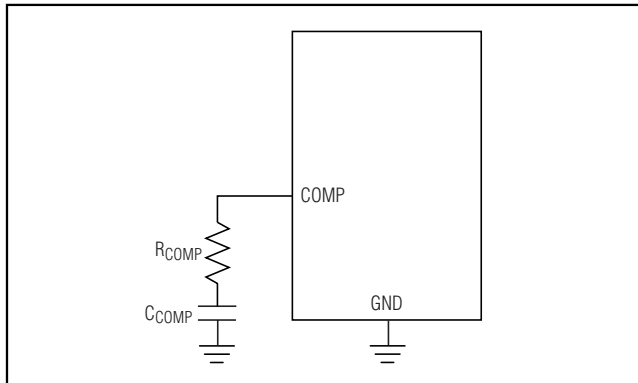

Figure 2. Alternative Compensation Circuit

PC Board Layout

Due to fast switching waveforms and high-current paths, careful PC board layout is required. An evaluation kit (MAX8596XEVKIT) is available to speed design.

When laying out a board, minimize trace lengths between the IC and R_{SENSE} , the inductor, the diode, the input capacitor, and the output capacitor. Keep traces short, direct, and wide. Keep noisy traces, such as the LX node trace, away from CS. The IN bypass capacitor (C_{IN}) should be placed as close to the IC as possible. PGND and GND should be connected directly to the exposed paddle underneath the IC. The ground connections of C_{IN} and C_{OUT} should be as close together as possible. The traces from IN to the inductor and from the Schottky diode to the LEDs can be longer.

Chip Information

TRANSISTOR COUNT: 2143

PROCESS: BiCMOS

High-Efficiency, 36V Step-Up Converters with T_A Derating Option for 2 to 9 White LEDs

Package Information

(The package drawing(s) in this data sheet may not reflect the most current specifications. For the latest package outline information, go to www.maxim-ic.com/packages.)

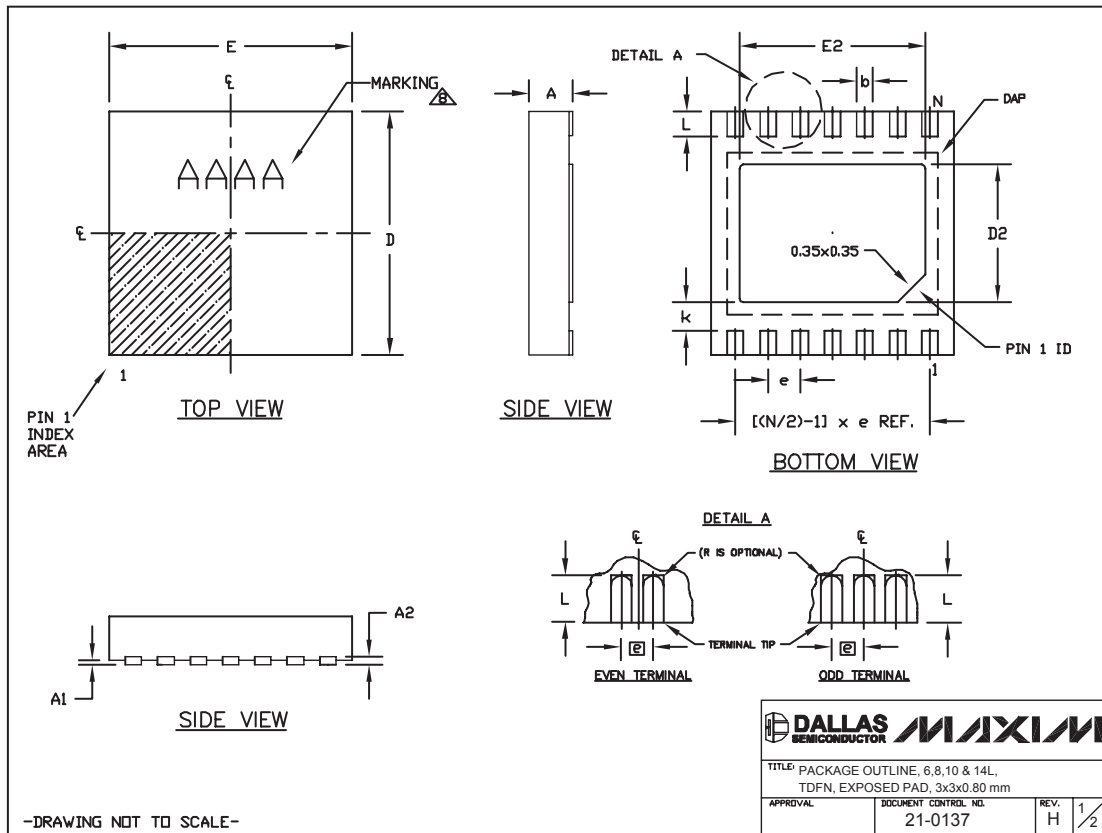

6, 8, & 10L, DFN THIN. EPS

MAX8595X/MAX8596X

High-Efficiency, 36V Step-Up Converters with T_A Derating Option for 2 to 9 White LEDs

Package Information (continued)

(The package drawing(s) in this data sheet may not reflect the most current specifications. For the latest package outline information, go to www.maxim-ic.com/packages.)

COMMON DIMENSIONS			PACKAGE VARIATIONS							
SYMBOL	MIN.	MAX.	PKG. CODE	N	D2	E2	e	JEDEC SPEC	b	[(N/2)-1] x e
A	0.70	0.80	T633-1	6	1.50±0.10	2.30±0.10	0.95 BSC	MO229 / WEEA	0.40±0.05	1.90 REF
D	2.90	3.10	T633-2	6	1.50±0.10	2.30±0.10	0.95 BSC	MO229 / WEEA	0.40±0.05	1.90 REF
E	2.90	3.10	T833-1	8	1.50±0.10	2.30±0.10	0.65 BSC	MO229 / WEEC	0.30±0.05	1.95 REF
A1	0.00	0.05	T833-2	8	1.50±0.10	2.30±0.10	0.65 BSC	MO229 / WEEC	0.30±0.05	1.95 REF
L	0.20	0.40	T833-3	8	1.50±0.10	2.30±0.10	0.65 BSC	MO229 / WEEC	0.30±0.05	1.95 REF
k	0.25 MIN.		T1033-1	10	1.50±0.10	2.30±0.10	0.50 BSC	MO229 / WEED-3	0.25±0.05	2.00 REF
A2	0.20 REF.		T1033-2	10	1.50±0.10	2.30±0.10	0.50 BSC	MO229 / WEED-3	0.25±0.05	2.00 REF
			T1433-1	14	1.70±0.10	2.30±0.10	0.40 BSC	----	0.20±0.05	2.40 REF
			T1433-2	14	1.70±0.10	2.30±0.10	0.40 BSC	----	0.20±0.05	2.40 REF

NOTES:
 1. ALL DIMENSIONS ARE IN mm. ANGLES IN DEGREES.
 2. COPLANARITY SHALL NOT EXCEED 0.08 mm.
 3. WARPAGE SHALL NOT EXCEED 0.10 mm.
 4. PACKAGE LENGTH/PACKAGE WIDTH ARE CONSIDERED AS SPECIAL CHARACTERISTIC(S).
 5. DRAWING CONFORMS TO JEDEC MO229, EXCEPT DIMENSIONS "D2" AND "E2", AND T1433-1 & T1433-2.
 6. "N" IS THE TOTAL NUMBER OF LEADS.
 7. NUMBER OF LEADS SHOWN ARE FOR REFERENCE ONLY.
 8. MARKING IS FOR PACKAGE ORIENTATION REFERENCE ONLY.

TITLE: PACKAGE OUTLINE, 6, 8, 10 & 14L, TDFN, EXPOSED PAD, 3x3x0.80 mm	
APPROVAL	DOCUMENT CONTROL NO. 21-0137
REV	H 2/2

-DRAWING NOT TO SCALE-

Revision History

Pages changed at Rev 2: 1, 2, 5-8

Maxim cannot assume responsibility for use of any circuitry other than circuitry entirely embodied in a Maxim product. No circuit patent licenses are implied. Maxim reserves the right to change the circuitry and specifications without notice at any time.

10 **Maxim Integrated Products, 120 San Gabriel Drive, Sunnyvale, CA 94086 408-737-7600**

Looking for pricing, stock, or lifecycle information?

Click below to explore more details on WIN SOURCE:

- ⊖ [View MAX8595XETA on WIN SOURCE](#)
- ⊖ [Maxim Integrated Information](#)

Optimize Your Supply Chain with WIN SOURCE Solutions

- ✓ Global Sourcing Solution
- ✓ Obsolete Management
- ✓ Cost Control Management
- ✓ Shortage Management
- ✓ Alternative Solution
- ✓ Excess Inventory Management