



# THE DATASHEET OF MAX8535EUA-T



# ORing MOSFET Controllers with Fastest Fault Isolation for Redundant Power Supplies

## General Description

Critical loads often employ parallel-connected power supplies with redundancy in order to enhance system reliability. The MAX8535/MAX8536/MAX8585 are highly integrated but inexpensive MOSFET controllers that provide isolation and redundant power capability in high-reliability systems. The MAX8535/MAX8585 are used in 12V systems, and have an internal charge pump to drive the gates of the n-channel pass elements to  $V_{CC} + 10V$ . The MAX8536 is used in 3.3V and 5V systems, with a charge-pump output of  $V_{CC} + 5V$ .

During startup, the MAX8535/MAX8536/MAX8585 monitor the voltage drop across external MOSFETs. Once  $V_{CC}$  approaches or exceeds the bus voltage, the MOSFETs are turned on. The MAX8535/MAX8536/MAX8585 feature a dual-purpose TIMER input. A single external resistor from TIMER to ground sets the turn-on speed of the external MOSFETs. Optionally, the TIMER input can be used as a logic-enable pin. Once the device is turned on, the MAX8535/MAX8536/MAX8585 monitor the load, protecting against overvoltage, undervoltage, and reverse-current conditions.

Overvoltage and undervoltage fault thresholds are adjustable and can be disabled. The current-limit trip points are set by the external MOSFETs'  $R_{DS(ON)}$ , reducing component count. An open-drain logic-low fault output indicates if an overvoltage, undervoltage, or reverse-current fault occurs.

All devices come in a space-saving 8-pin  $\mu$ MAX® package and are specified over the extended  $-40^{\circ}\text{C}$  to  $+85^{\circ}\text{C}$  temperature range.

$\mu$ MAX is a registered trademark of Maxim Integrated Products, Inc.

## Applications

- Silver Box Supplies for Servers
- On-Board Redundant Power Supplies in Blade Servers
- Network/Telecom Power Supplies
- Rectifiers
- Redundant Power Supplies in High-Availability Systems

**Pin Configuration, Functional Diagrams, and Typical Application Circuits appear at end of data sheet.**

## Features

- ◆ Simple, Integrated, and Inexpensive ORing MOSFET Controller
- ◆ ORing MOSFET Drive for 12V (MAX8535/MAX8585) and 3.3V or 5V (MAX8536) Bus
- ◆ Eliminates ORing Diode Power Dissipation and Reverse Leakage Current
- ◆ Provides N + 1 Redundant Supply Capability for Highly Reliable Systems
- ◆ Isolates Failed Supply from Output Bus in  $<1\mu\text{s}$
- ◆ Reverse-Current Flow Detection
- ◆ Programmable Soft-Start
- ◆ Logic-Enable Input
- ◆ Adjustable Overvoltage and Undervoltage Trip Points
- ◆ Fault-Indicator Output
- ◆ Space-Saving 8-Pin  $\mu$ MAX Package

## Ordering Information

PART	TEMP RANGE	PIN-PACKAGE
MAX8535EUA	$-40^{\circ}\text{C}$ to $+85^{\circ}\text{C}$	8 $\mu$ MAX
MAX8535AEUA	$-40^{\circ}\text{C}$ to $+85^{\circ}\text{C}$	8 $\mu$ MAX
MAX8536EUA	$-40^{\circ}\text{C}$ to $+85^{\circ}\text{C}$	8 $\mu$ MAX
MAX8585EUA	$-40^{\circ}\text{C}$ to $+85^{\circ}\text{C}$	8 $\mu$ MAX

## Typical Operating Circuit

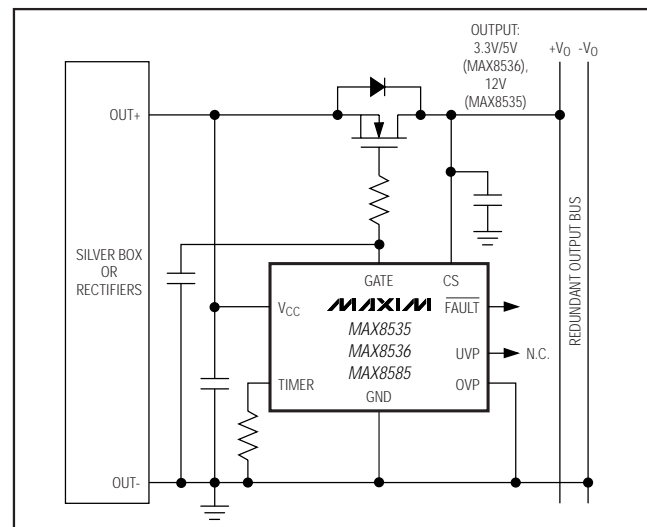

# ORing MOSFET Controllers with Fastest Fault Isolation for Redundant Power Supplies

## ABSOLUTE MAXIMUM RATINGS

GATE to GND (MAX8535/MAX8535A/MAX8585) .....-0.3V to +28V  
 V<sub>CC</sub> to GND (MAX8535/MAX8535A/MAX8585) .....-0.3V to +18V  
 CS, FAULT to GND  
 (MAX8535/MAX8535A/MAX8585) .....-0.3V to +15V  
 GATE to GND (MAX8536) ..... -0.3V to (V<sub>CC</sub> + 6V)  
 V<sub>CC</sub>, CS, FAULT to GND (MAX8536) .....-0.3V to +6V  
 OVP, UVP, TIMER to GND .....-0.3V to +6V

Continuous Power Dissipation (T<sub>A</sub> = +70°C)  
 8-Pin μMAX (derate 4.5mW/°C above +70°C) .....362mW  
 Operating Temperature Range .....-40°C to +85°C  
 Storage Temperature Range .....-65°C to +150°C  
 Junction Temperature .....+150°C  
 Lead Temperature (soldering, 10s) .....+300°C

Stresses beyond those listed under "Absolute Maximum Ratings" may cause permanent damage to the device. These are stress ratings only, and functional operation of the device at these or any other conditions beyond those indicated in the operational sections of the specifications is not implied. Exposure to absolute maximum rating conditions for extended periods may affect device reliability.

## ELECTRICAL CHARACTERISTICS

(V<sub>CC</sub> = 12V (MAX8535/MAX8535A/MAX8585), V<sub>CC</sub> = 5V (MAX8536), V<sub>CS</sub> = V<sub>CC</sub> - 0.1V, R<sub>TIMER</sub> = 25kΩ, UVP = 2V, OVP = 1V, C<sub>GATE</sub> = 0.01μF, T<sub>A</sub> = 0°C to +85°C, unless otherwise noted.)

PARAMETER	SYMBOL	CONDITIONS	MIN	TYP	MAX	UNITS	
<b>V<sub>CC</sub> SUPPLY</b>							
V <sub>CC</sub> Supply Current		TIMER = 2.5V	V <sub>CC</sub> = 14V (MAX8535/ MAX8535A/MAX8585)	2	4.5	mA	
			V <sub>CC</sub> = 6V (MAX8536)	2	3		
V <sub>CC</sub> Shutdown Current		TIMER = 0V	V <sub>CC</sub> = 14V (MAX8535/ MAX8535A/MAX8585)		4.5	mA	
			V <sub>CC</sub> = 6V (MAX8536)		3		
V <sub>CC</sub> Input Voltage		TIMER = 2.5V	MAX8535/MAX8535A/ MAX8585, charge pump on	8	14	V	
			MAX8536, charge pump on	3.0	5.5		
			MAX8535/MAX8535A/ MAX8585, charge pump off		17		
CS Input Current		TIMER = 2.5V	CS = 14V (MAX8535/ MAX8535A/MAX8585)	100		μA	
			CS = 5.5V (MAX8536)	50			
CS Isolation		CS = max operating voltage, V <sub>CC</sub> = 0V, I(V <sub>CC</sub> )	-0.05	-1		μA	
V <sub>CC</sub> Undervoltage Lockout	V <sub>CCOK</sub>	MAX8535/MAX8535A/MAX8585, rising threshold	6	6.5	7	V	
		MAX8536, rising threshold	2.5	2.7	2.9		
V <sub>CC</sub> Overvoltage Internal Threshold		MAX8535/ MAX8535A/ MAX8585	Rising threshold	14	14.5	15	V
			Falling threshold	13.3	13.9	14.5	
<b>CHARGE-PUMP VOLTAGE</b>							
Gate Voltage	V <sub>GATE</sub>	Measured from V <sub>GATE</sub> to V <sub>CC</sub> , V <sub>CC</sub> = 3.3V (MAX8536)	5	5.5	6	V	
		V <sub>CC</sub> = 5V (MAX8536)	5	5.5	6		
		V <sub>CC</sub> = 12V (MAX8535/MAX8535A/MAX8585)	9	11	12		

# ORing MOSFET Controllers with Fastest Fault Isolation for Redundant Power Supplies

MAX8535/MAX8536/MAX8585

## ELECTRICAL CHARACTERISTICS (continued)

(V<sub>CC</sub> = 12V (MAX8535/MAX8535A/MAX8585), V<sub>CC</sub> = 5V (MAX8536), V<sub>CS</sub> = V<sub>CC</sub> - 0.1V, R<sub>TIMER</sub> = 25kΩ, UVP = 2V, OVP = 1V, C<sub>GATE</sub> = 0.01μF, T<sub>A</sub> = 0°C to +85°C, unless otherwise noted.)

PARAMETER	SYMBOL	CONDITIONS	MIN	TYP	MAX	UNITS	
Charge-Pump Switching Frequency		R <sub>TIMER</sub> = 20kΩ		187		kHz	
		R <sub>TIMER</sub> = 125kΩ		450			
		R <sub>TIMER</sub> = open		500			
		V <sub>TIMER</sub> = 1.5V		550			
<b>TIMER</b>							
TIMER Voltage			1.219	1.25	1.281	V	
TIMER Maximum Source Current		V <sub>TIMER</sub> = 1V	80	100	120	μA	
TIMER High-Input Current		V <sub>TIMER</sub> = 1.5V		10	20	μA	
TIMER Maximum Frequency Select Voltage Input Range		MAX8535/MAX8535A/MAX8585	1.5		3.4	V	
		MAX8536	1.5		V <sub>CC</sub> - 0.6		
TIMER Logic High	V <sub>IH</sub>	Charge pump enabled	1.0			V	
TIMER Logic Low	V <sub>IL</sub>	Charge pump disabled			0.5	V	
<b>FAULT</b>							
Fault Output Low Voltage		I <sub>FAULT</sub> = 0.5mA			0.8	V	
Fault Sink Current		FAULT = 0.8V	0.5			mA	
Fault Leakage Current		FAULT = 18V (MAX8535/MAX8535A/MAX8585)			5	μA	
		FAULT = 6V (MAX8536)			5		
<b>GATE</b>							
Gate On Threshold		Measured from V <sub>CC</sub> to CS	0.3	0.4	0.5	V	
Gate Drive Current		V <sub>GATE</sub> = V <sub>CC</sub> = 12V	I <sub>TIMER</sub> = 0μA (MAX8535/MAX8535A/MAX8585)	35	50	65	μA
			I <sub>TIMER</sub> = 50μA (MAX8535/MAX8535A/MAX8585)	15	25	36	
		V <sub>GATE</sub> = V <sub>CC</sub> = 5V	I <sub>TIMER</sub> = 0μA (MAX8536)	17	25	33	
			I <sub>TIMER</sub> = 50μA (MAX8536)	8	12	16	
Gate Shutdown Delay		From fault sense to the start of gate voltage falling, or from TIMER to the start of gate voltage falling		200	300	ns	
Gate Discharge Current		GATE = V <sub>CC</sub> + 5V (MAX8535/MAX8536)	100	200	300	mA	
		GATE = V <sub>CC</sub> + 5V (MAX8535A/MAX8585)	200	300	400		
Gate Fall Time		Gate voltage fall from fault to V <sub>GATE</sub> = V <sub>CC</sub> , C <sub>GATE</sub> = 0.01μF (200ns + CV/I = 700ns, typ) (MAX8535/MAX8536)		0.7		μs	
		MAX8535A/MAX8585		0.55			
<b>CURRENT SENSE</b>							
Reverse-Current Threshold		Measured from CS to V <sub>CC</sub> (MAX8535/MAX8535A/MAX8536)	20	30	40	mV	
		MAX8585	-3	0	+3		

# ORing MOSFET Controllers with Fastest Fault Isolation for Redundant Power Supplies

MAX8535/MAX8536/MAX8585

## ELECTRICAL CHARACTERISTICS (continued)

( $V_{CC} = 12V$  (MAX8535/MAX8535A/MAX8585),  $V_{CC} = 5V$  (MAX8536),  $V_{CS} = V_{CC} - 0.1V$ ,  $R_{TIMER} = 25k\Omega$ ,  $UVP = 2V$ ,  $OVP = 1V$ ,  $C_{GATE} = 0.01\mu F$ ,  $T_A = 0^\circ C$  to  $+85^\circ C$ , unless otherwise noted.)

PARAMETER	SYMBOL	CONDITIONS	MIN	TYP	MAX	UNITS
Startup Reverse-Current Blank Time		TIMER = open (MAX8535/MAX8535A/MAX8536)		524		ms
		MAX8585		32		
Forward-Current Threshold		Measured from $V_{CC}$ to CS	5	10	15	mV
<b>OVERVOLTAGE PROTECTION</b>						
OVP Fault Threshold	$V_{OVP}$	OVP rising	1.219	1.25	1.281	V
		OVP falling		1.2		
OVP Bias Current					0.2	$\mu A$
<b>UNDERVOLTAGE PROTECTION</b>						
UVP Fault Voltage	$V_{UVP}$	UVP rising threshold	1.219	1.25	1.281	V
		UVP falling threshold	1.119	1.15	1.181	
UVP Bias Current					0.4	$\mu A$

## ELECTRICAL CHARACTERISTICS

( $V_{CC} = 12V$  (MAX8535/MAX8535A/MAX8585),  $V_{CC} = 5V$  (MAX8536),  $V_{CS} = V_{CC} - 0.1V$ ,  $R_{TIMER} = 25k\Omega$ ,  $UVP = 2V$ ,  $OVP = 1V$ ,  $C_{GATE} = 0.01\mu F$ ,  $T_A = -40^\circ C$  to  $+85^\circ C$ , unless otherwise noted.) (Note 1)

PARAMETER	SYMBOL	CONDITIONS	MIN	TYP	MAX	UNITS
<b><math>V_{CC}</math> SUPPLY</b>						
$V_{CC}$ Supply Current		TIMER = 2.5V	$V_{CC} = 14V$ (MAX8535/MAX8535A/MAX8585)		4.5	mA
			$V_{CC} = 6V$ (MAX8536)		3	
$V_{CC}$ Shutdown Current		TIMER = 0V	$V_{CC} = 14V$ (MAX8535/MAX8535A/MAX8585)		4.5	mA
			$V_{CC} = 6V$ (MAX8536)		3	
$V_{CC}$ Input Voltage		TIMER = 2.5V	MAX8535/MAX8535A/MAX8585, charge pump on	8	14	V
			MAX8536, charge pump on	3.0	5.5	
			MAX8535/MAX8535A/MAX8585, charge pump off		17	
CS Isolation		CS = max operating voltage, $V_{CC} = 0V$ , $I(V_{CC})$			-1	$\mu A$
$V_{CC}$ Undervoltage Lockout	$V_{CCOK}$	(MAX8535/MAX8535A/MAX8585) rising threshold	6.0		7.0	V
		(MAX8536) rising threshold	2.5		2.9	
$V_{CC}$ Overvoltage Internal Threshold		(MAX8535/MAX8535A/MAX8585)	Rising threshold	14	15	V
			Falling threshold	13.3	14.5	

# ORing MOSFET Controllers with Fastest Fault Isolation for Redundant Power Supplies

MAX8535/MAX8536/MAX8585

## ELECTRICAL CHARACTERISTICS (continued)

( $V_{CC} = 12V$  (MAX8535/MAX8535A/MAX8585),  $V_{CC} = 5V$  (MAX8536),  $V_{CS} = V_{CC} - 0.1V$ ,  $R_{TIMER} = 25k\Omega$ ,  $UVP = 2V$ ,  $OVP = 1V$ ,  $C_{GATE} = 0.01\mu F$ ,  $T_A = -40^\circ C$  to  $+85^\circ C$ , unless otherwise noted.) (Note 1)

PARAMETER	SYMBOL	CONDITIONS	MIN	TYP	MAX	UNITS
<b>CHARGE-PUMP VOLTAGE</b>						
Gate Voltage	$V_{GATE}$	Measured from $V_{GATE}$ to $V_{CC}$ , $V_{CC} = 3.3V$ (MAX8536)	5		6	V
		$V_{CC} = 5V$ (MAX8536)	5		6	
		$V_{CC} = 12V$ (MAX8535/MAX8535A/MAX8585)	9		12	
<b>TIMER</b>						
TIMER Voltage			1.200		1.281	V
TIMER Maximum Source Current		$V_{TIMER} = 1.0V$	80		120	$\mu A$
TIMER High-Input Current		$V_{TIMER} = 1.5V$			20	$\mu A$
TIMER Maximum Frequency Select Voltage Input Range		MAX8535/MAX8535A/MAX8585	1.5		3.4	V
		MAX8536	1.5		$V_{CC} - 0.6$	
TIMER Logic High	$V_{IH}$	Charge pump enabled	1.1			V
TIMER Logic Low	$V_{IL}$	Charge pump disabled			0.5	V
<b>FAULT</b>						
Fault Output Low Voltage		$I_{FAULT} = 0.5mA$			0.8	V
Fault Sink Current		$FAULT = 0.8V$	0.5			mA
Fault Leakage Current		$FAULT = 18V$ (MAX8535/MAX8535A/MAX8585)			5	$\mu A$
		$FAULT = 6V$ (MAX8536)			5	
<b>GATE</b>						
Gate On Threshold		Measured from $V_{CC}$ to CS	0.3		0.5	V
Gate-Drive Current	$V_{GATE} = V_{CC} = 12V$	$I_{TIMER} = 0\mu A$ (MAX8535/MAX8535A/MAX8585)	35		65	$\mu A$
		$I_{TIMER} = 50\mu A$ (MAX8535/MAX8535A/MAX8585)	15		36	
	$V_{GATE} = V_{CC} = 5V$	$I_{TIMER} = 0\mu A$ (MAX8536)	17		33	
		$I_{TIMER} = 50\mu A$ (MAX8536)	8		16	
Gate Shutdown Delay		From fault sense to the start of gate voltage falling, or from TIMER to the start of gate voltage falling			300	ns
Gate Discharge Current		$GATE = V_{CC} + 5V$ (MAX8535/MAX8536)	100		300	mA
		MAX8535A/MAX8585	200		400	
<b>CURRENT SENSE</b>						
Reverse-Current Threshold		Measured from CS to $V_{CC}$ (MAX8535/MAX8535A/MAX8586)	20		40	mV
		MAX8585	-5		+5	
Forward-Current Threshold		Measured from $V_{CC}$ to CS	5		15	mV

# ORing MOSFET Controllers with Fastest Fault Isolation for Redundant Power Supplies

## ELECTRICAL CHARACTERISTICS (continued)

( $V_{CC} = 12V$  (MAX8535/MAX8535A/MAX8585),  $V_{CC} = 5V$  (MAX8536),  $V_{CS} = V_{CC} - 0.1V$ ,  $R_{TIMER} = 25k\Omega$ ,  $UVP = 2V$ ,  $OVP = 1V$ ,  $C_{GATE} = 0.01\mu F$ ,  $T_A = -40^\circ C$  to  $+85^\circ C$ , unless otherwise noted.) (Note 1)

PARAMETER	SYMBOL	CONDITIONS	MIN	TYP	MAX	UNITS
<b>OVERVOLTAGE PROTECTION</b>						
OVP Fault Threshold	$V_{OVP}$	OVP rising	1.20		1.281	V
OVP Bias Current					0.2	$\mu A$
<b>UNDERVOLTAGE PROTECTION</b>						
UVP Fault Voltage	$V_{UVP}$	UVP rising threshold	1.200		1.281	V
		UVP falling threshold	1.10		1.19	
UVP Bias Current					0.4	$\mu A$

**Note 1:** Specifications to  $-40^\circ C$  are guaranteed by design and not production tested.

# ORing MOSFET Controllers with Fastest Fault Isolation for Redundant Power Supplies

State Diagram

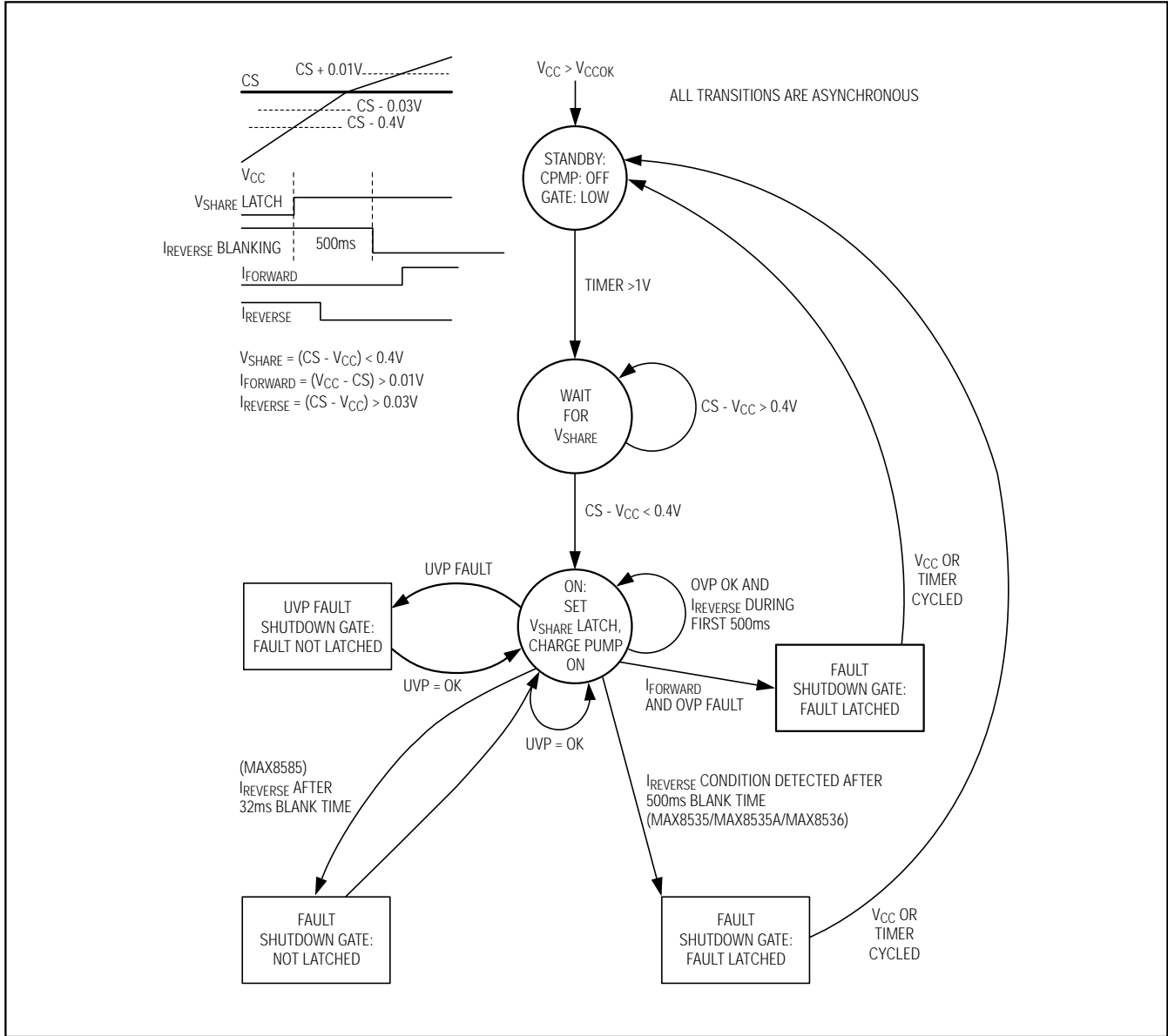

MAX8535/MAX8536/MAX8585

# ORing MOSFET Controllers with Fastest Fault Isolation for Redundant Power Supplies

## MAX8535 Typical Operating Characteristics

( $V_{CC} = 12V$ ,  $R_{TIMER} = 25k\Omega$ ,  $UVP = 2V$ ,  $OVP = 1V$ ,  $C_{GATE} = 0.01\mu F$ ,  $BUS = 100\mu F$ ,  $T_A = +25^\circ C$ , unless otherwise specified.)

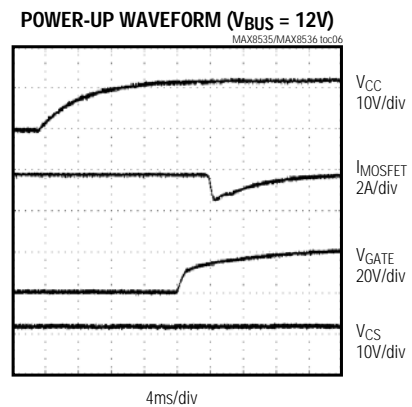
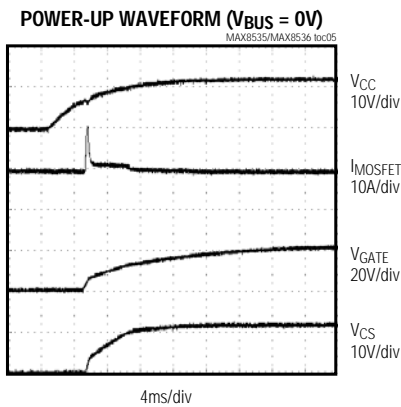
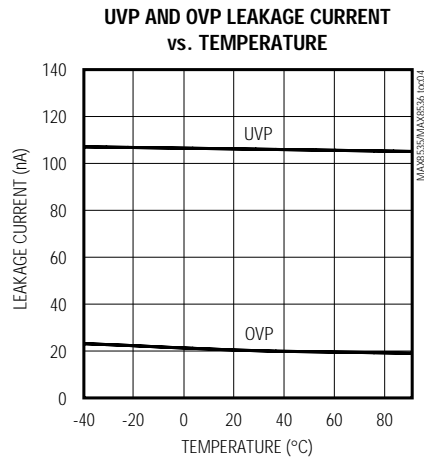
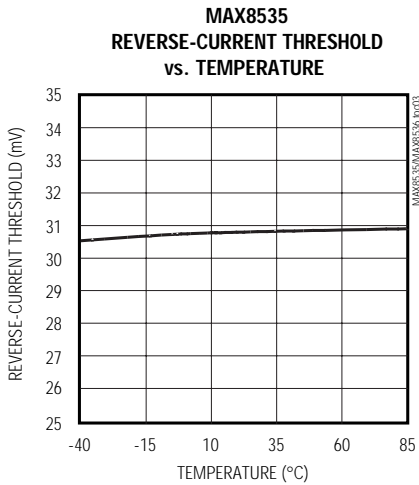
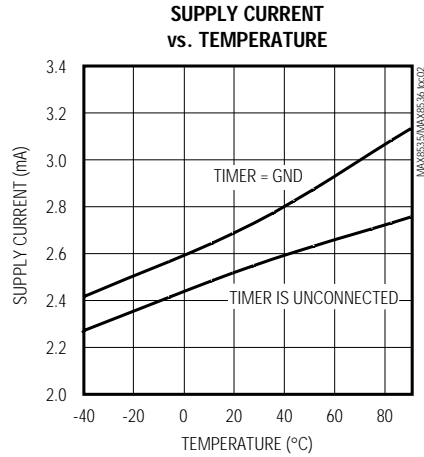
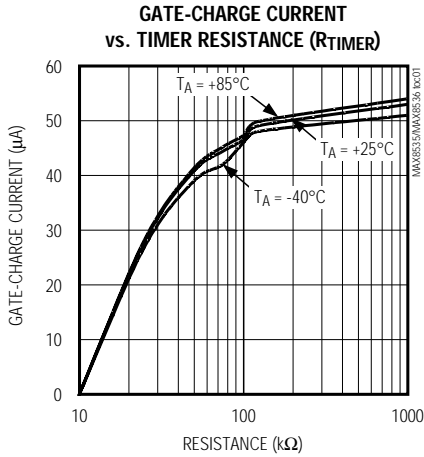

# ORing MOSFET Controllers with Fastest Fault Isolation for Redundant Power Supplies

## MAX8535 Typical Operating Characteristics (continued)

( $V_{CC} = 12V$ ,  $R_{TIMER} = 25k\Omega$ ,  $UVP = 2V$ ,  $OVP = 1V$ ,  $C_{GATE} = 0.01\mu F$ ,  $BUS = 100\mu F$ ,  $T_A = +25^\circ C$ , unless otherwise specified.)

MAX8535/MAX8536/MAX8585

**TIMER-ENABLED STARTUP AND SHUTDOWN WAVEFORMS ( $V_{CC} = 12V$ ,  $V_{BUS} = 12V$ )**

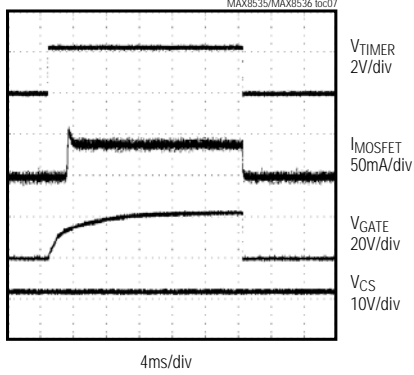

**TIMER-ENABLED STARTUP AND SHUTDOWN WAVEFORMS ( $V_{CC} = 12V$ ,  $V_{BUS} = 0V$ )**

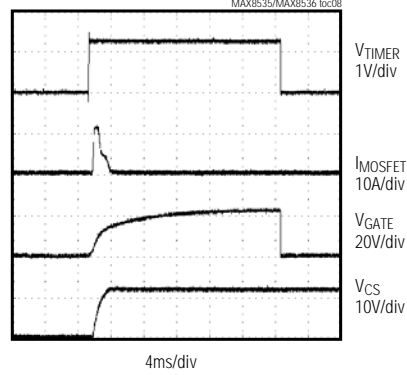

**REVERSE-CURRENT FAULT WAVEFORM ( $R_1 = 10\Omega$ )**

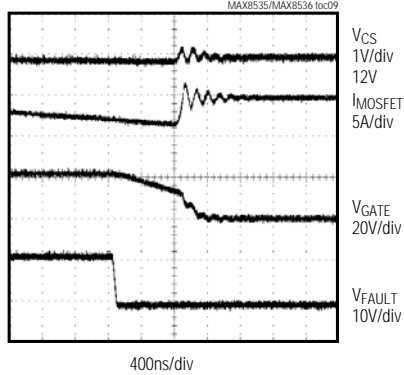

**UVP FAULT WAVEFORM ( $R_1 = 100\Omega$ )**

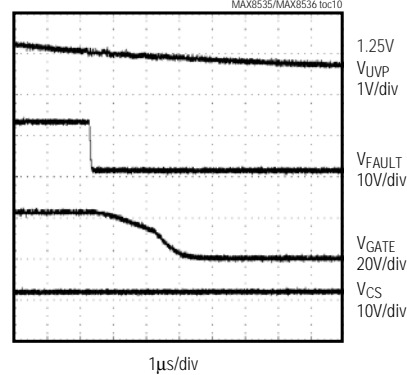

**SELECTIVE OVP SHUTDOWN WAVEFORM ( $R_1 = 10\Omega$ )**

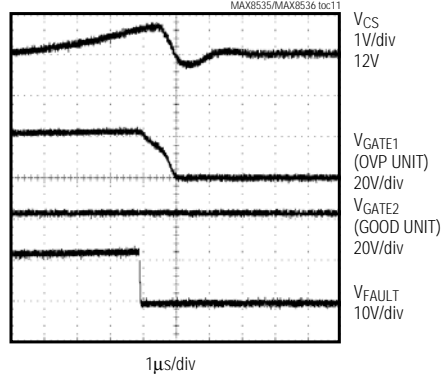

# ORing MOSFET Controllers with Fastest Fault Isolation for Redundant Power Supplies

## MAX8536 Typical Operating Characteristics

( $V_{CC} = 12V$ ,  $R_{TIMER} = 25k\Omega$ ,  $UVP = 2V$ ,  $OVP = 1V$ ,  $C_{GATE} = 0.01\mu F$ ,  $BUS = 100\mu F$ ,  $T_A = +25^\circ C$ , unless otherwise specified.)

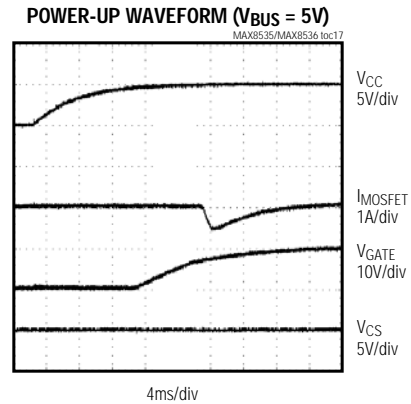
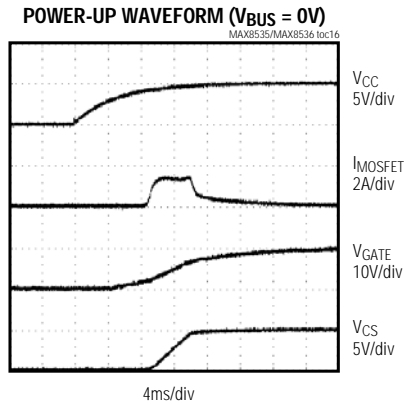
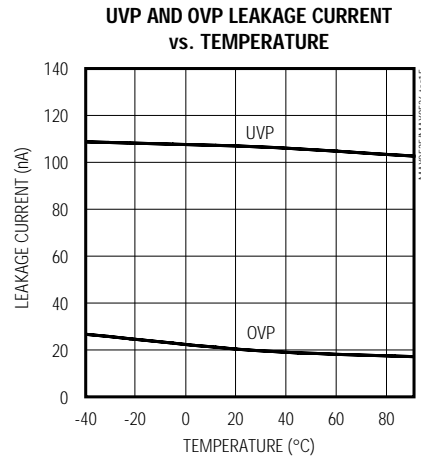
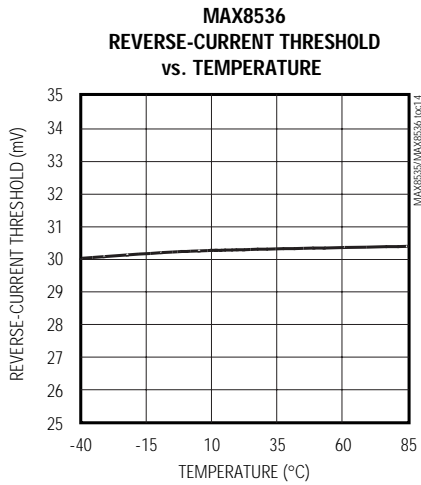
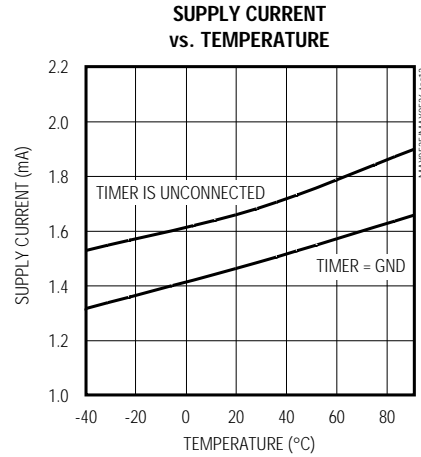
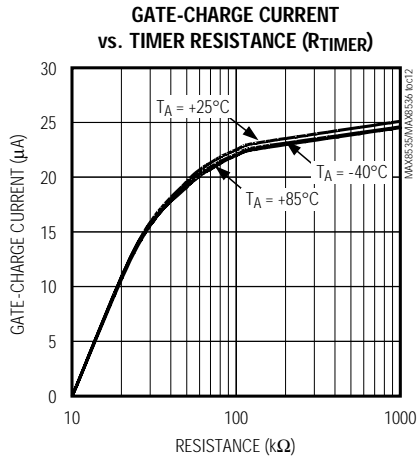

# ORing MOSFET Controllers with Fastest Fault Isolation for Redundant Power Supplies

## MAX8536 Typical Operating Characteristics (continued)

( $V_{CC} = 12V$ ,  $R_{TIMER} = 25k\Omega$ ,  $UVP = 2V$ ,  $OVP = 1V$ ,  $C_{GATE} = 0.01\mu F$ ,  $BUS = 100\mu F$ ,  $T_A = +25^\circ C$ , unless otherwise specified.)

MAX8535/MAX8536/MAX8585

**TIMER-ENABLED STARTUP AND SHUTDOWN WAVEFORMS ( $V_{CC} = 5V$ ,  $V_{BUS} = 5V$ )**

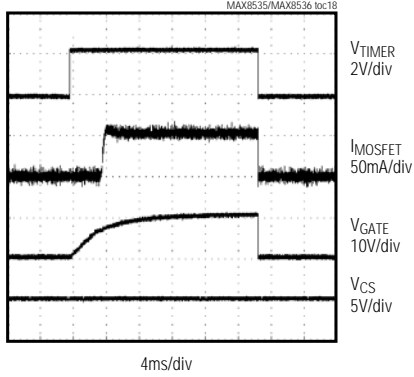

**TIMER-ENABLED STARTUP AND SHUTDOWN WAVEFORMS ( $V_{CC} = 5V$ ,  $V_{BUS} = 0V$ )**

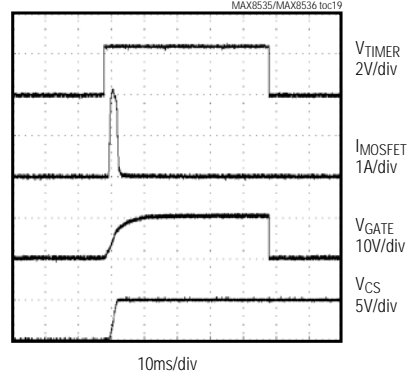

**REVERSE-CURRENT FAULT WAVEFORM ( $R_1 = 10\Omega$ )**

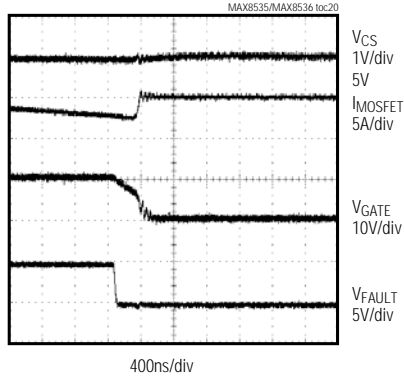

**UVP FAULT WAVEFORM ( $R_1 = 100\Omega$ )**

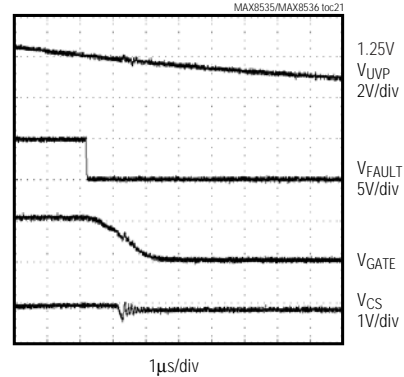

**SELECTIVE OVP SHUTDOWN WAVEFORM ( $R_1 = 10\Omega$ )**

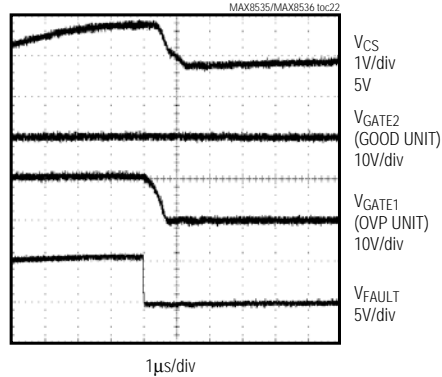

# ORing MOSFET Controllers with Fastest Fault Isolation for Redundant Power Supplies

## Pin Description

PIN	NAME	FUNCTION
1	GATE	Gate Drive Output. Bypass GATE with a 0.01 $\mu$ F capacitor to ground.
2	GND	Ground
3	V <sub>CC</sub>	Power-Supply Input. Bypass V <sub>CC</sub> with a 0.1 $\mu$ F capacitor to ground.
4	UVP	Undervoltage Input. Connect a resistor-divider from the V <sub>CC</sub> to GND with the center point connected to UVP. Leave high impedance if not used. UVP fault threshold must be set above V <sub>CCOK</sub> threshold.
5	TIMER	Timer Input. Connect a resistor from TIMER to ground to select the charge-pump operating frequency. The charge-pump frequency is proportional to the TIMER output current. TIMER can source up to 100 $\mu$ A. If pulled low (<0.5V), the gate drive is disabled. If pulled high (above 1.25V), the charge pump operates at 550kHz.
6	OVP	Overvoltage Input. Connect a resistor-divider from the CS to GND with the center point connected to OVP. Connect to GND if not used.
7	$\overline{\text{FAULT}}$	Open-Drain Fault Output. $\overline{\text{FAULT}}$ is low during a fault, high impedance during normal operation. Connect a pullup resistor of 50k $\Omega$ or higher value to a voltage rail.
8	CS	Current-Sensing Input. Connect CS to the positive side of the system bus. Bypass with 1nF capacitor to GND.

## Detailed Description

Critical loads often employ parallel-connected power supplies with redundancy to enhance system reliability. The MAX8535/MAX8536/MAX8585 are highly integrated but inexpensive MOSFET controllers that provide isolation and redundant power capability in high-reliability systems. The MAX8535/MAX8585 is used in 12V systems and has an internal charge pump to drive the gates of the n-channel pass elements to V<sub>CC</sub> + 10V. The MAX8536 is used in 3.3V and 5V systems, with a charge pump output of V<sub>CC</sub> + 5V.

During startup, the MAX8535/MAX8536/MAX8585 monitor the voltage drop across external MOSFETs. Once V<sub>CC</sub> approaches or exceeds the bus voltage, the MOSFETs are turned on. The MAX8535/MAX8536/MAX8585 feature a dual-purpose TIMER input. A single external resistor from TIMER to ground sets the turn-on speed of the external MOSFETs. Optionally, the TIMER input can be used as a logic-enable pin. Once the device is turned on, the MAX8535/MAX8536/MAX8585 monitor the load, protecting against overvoltage, undervoltage, and reverse-current conditions.

Overvoltage and undervoltage fault thresholds are adjustable and can be disabled. The current-limit trip points are set by the external MOSFETs' R<sub>DS(ON)</sub>, reducing component count. An open-drain logic-low fault output indicates if an overvoltage, undervoltage, or reverse-current fault occurs.

**V<sub>CC</sub>**  
V<sub>CC</sub> is the power-supply input for the MAX8535/MAX8536/MAX8585 and the input to the internal charge pump that drives the gate of the external MOSFETs. The MAX8535/MAX8536/MAX8585 monitor V<sub>CC</sub> at all times. V<sub>CC</sub> connects directly to the power supply (Silver Box or DC-DC power modules). During startup, the device turns on when V<sub>CC</sub> rises above the undervoltage threshold V<sub>CCOK</sub>. After V<sub>CC</sub> exceeds V<sub>CCOK</sub> and V<sub>CC</sub> is greater than (CS - 0.4V), the charge pump turns on, driving GATE high and turning on the external MOSFETs.

**TIMER**  
The MAX8535/MAX8536/MAX8585 provide a programmable-frequency charge pump and shutdown function through TIMER. Slowing down the charge-pump frequency allows a user to program soft-start. Connecting a resistor from TIMER to GND sets the charge-pump frequency from 100kHz to 500kHz. Connecting TIMER to a logic high sets charge-pump operation to a maximum frequency of 550kHz. Pulling TIMER to GND shuts down the charge pump and turns off the external MOSFET. Reducing the charge-pump frequency increases the I<sub>REVERSE</sub> startup blank time (see the *Reverse-Current Fault* section).

**GATE**  
GATE is the output of the internal charge pump that drives the external MOSFETs. During startup, the GATE voltage ramps up according to the charge-pump frequency. At 250kHz, the GATE drive current for the MAX8535/MAX8585 is 25 $\mu$ A and the GATE drive current

# ORing MOSFET Controllers with Fastest Fault Isolation for Redundant Power Supplies

for the MAX8536 is 12µA. Increasing the charge-pump frequency increases the GATE drive current. Adding a resistor from GATE to the gate of the external MOSFETs further increases turn-on and turn-off times.

## CS

The voltage drop across the external MOSFETs is measured between the V<sub>CC</sub> and CS inputs. CS connects to the positive side of the system bus. The voltage drop across the CS and V<sub>CC</sub> determines operation modes. I<sub>FORWARD</sub> is defined as V<sub>CC</sub> - CS > 0.01V. I<sub>REVERSE</sub> is defined as CS - V<sub>CC</sub> > 0.03V in all except the MAX8585. In the MAX8585, I<sub>REVERSE</sub> = 0V.

## FAULT Conditions

The MAX8535/MAX8536/MAX8585 contain a versatile  $\overline{\text{FAULT}}$  output that signals overvoltage, undervoltage, or reverse-current conditions. During a  $\overline{\text{FAULT}}$  condition, the charge pump shuts down and the GATE discharges to ground.

## Undervoltage Fault

The MAX8535/MAX8536/MAX8585 turn off the external MOSFET if the input voltage falls below the UVP threshold. If UVP is left unconnected, the undervoltage input is disabled. Set the undervoltage threshold to any value above V<sub>CCOK</sub>. When the input voltage rises above the UVP threshold,  $\overline{\text{FAULT}}$  clears and the MOSFET turns back on.

## Overvoltage Fault

The MAX8535/MAX8536/MAX8585 contain an adjustable OVP feature. A resistor-divider from the CS system bus to the OVP input pin sets the overvoltage threshold. When the OVP level is exceeded and the part is in the I<sub>FORWARD</sub> condition (defined as V<sub>CC</sub> > CS + 0.01V), the MAX8535/MAX8536/MAX8585 turn off the external MOSFET and a fault is latched. If there is no I<sub>FORWARD</sub> condition, an OVP detection has no

effect. In this way, only the input supply, which is causing the overvoltage condition, is turned off in a redundant power system application. An overvoltage fault is a latching fault condition, and requires V<sub>CC</sub> or TIMER to be cycled to reset the part.

## Reverse-Current Fault

The MAX8535/MAX8536 contain a reverse-current protection feature. If, after the 500ms (typ) startup blank time, an I<sub>REVERSE</sub> condition is detected, the MAX8535/MAX8536 turn off the external MOSFET and a fault is latched. A reverse-current fault forces the MAX8535/MAX8536 to latch off. Cycle V<sub>CC</sub> or TIMER to exit a latched fault condition. Startup blanking time allows the incoming power supply to connect to the system bus at V<sub>BUS</sub> - 0.4V. Reducing charge-pump frequency increases the startup blanking time. The MAX8585 does not latch this fault.

## Applications Information

### Selecting the Timer Resistor

To set the frequency of the internal charge-pump operation, connect a resistor from TIMER to GND. Determine the frequency by using the equation:

$$\text{Frequency} = 5 \times \left( 100\mu\text{A} - \frac{1.25\text{V}}{R_{\text{TIMER}}} \right) \text{ kHz}/\mu\text{A}$$

Pull TIMER above 1.5V for maximum charge-pump frequency. Pull TIMER below 0.5V to disable the charge pump. Leave TIMER unconnected for a 500kHz charge-pump frequency.

### Selecting the Gate Capacitor and Gate Resistor

The charge pump uses an internal monolithic transfer capacitor to charge the external MOSFET gates.

**Table 1. MAX8535/MAX8536/MAX8585 Fault Modes**

FAULT MODE	PIN CONDITIONS	GATE PIN	$\overline{\text{FAULT}}$ PIN	LATCHING
V <sub>CC</sub> UVLO	V <sub>CC</sub> < V <sub>CCOK</sub>	Low	High impedance	No
UVP pin undervoltage protection	UVP < 1.25V	Low	Low	No
OVP pin overvoltage protection	OVP > 1.25V V <sub>CC</sub> > CS + 0.01V	Low	Low	Yes
Reverse-current protection (MAX8535/MAX8536)	V <sub>CC</sub> < CS - 0.03V Gate ON for t > 0.5s	Low	Low	Yes
Reverse-current protection (MAX8585)	V <sub>CC</sub> < CS Gate ON for t > 0.032s	Low	Low	No
V <sub>CC</sub> internal (MAX8535/MAX8585) overvoltage protection	V <sub>CC</sub> > 14.5V	Low	Low	No

# ORing MOSFET Controllers with Fastest Fault Isolation for Redundant Power Supplies

Normally, the external MOSFET's gate capacitance is sufficient to serve as a reservoir capacitor. If the MOSFETs are located at a significant distance from the MAX8535/MAX8536/MAX8585, place a local bypass capacitor (0.01 $\mu$ F, typ) across GATE and GND. For slower turn-on times, add a small capacitor between GATE and GND and a series resistor between GATE and the gate of the MOSFETs.

## Set the UVP Fault Threshold

To set the undervoltage lockout threshold, use a resistor-divider connected between V<sub>CC</sub> and GND, with the center node of the divider connected to UVP. For example, use a 10k $\Omega$  resistor (R4 in Figure 4) from UVP to GND and calculate the other resistor (R3) using:

$$R3 = R4 \left( \frac{V_{UVLO}}{V_{UVP}} - 1 \right)$$

where V<sub>UVLO</sub> is the desired undervoltage lockout voltage and V<sub>UVP</sub> is the UVP reference threshold specified in the *Electrical Characteristics* (1.25V, typ). To defeat the UVP, leave UVP unconnected.

## Set the OVP Fault Threshold

To set the OVP threshold, use a resistor-divider connected between CS and GND, with the center node of the divider connected to OVP. For example, use a 10k $\Omega$  resistor (R6 in Figure 4) from OVP to GND and calculate the other resistor, R5, using:

$$R5 = R6 \left( \frac{V_{OVLO}}{V_{OVP}} - 1 \right)$$

where V<sub>OVLO</sub> is the desired overvoltage lockout voltage and V<sub>OVP</sub> is the OVP reference threshold specified in the *Electrical Characteristics* (1.25V, typ). To defeat the OVP, connect the OVP input to GND.

## MOSFET Selection

The MAX8535/MAX8536/MAX8585 drive n-channel MOSFETs. The most important feature of the MOSFETs is R<sub>DS(ON)</sub>. As load current flows through the external MOSFET, a voltage (V<sub>DS</sub>) is generated from drain-to-source due to the MOSFET's on-resistance, R<sub>DS(ON)</sub>. The MAX8535/MAX8536/MAX8585 monitor V<sub>DS</sub> of the

MOSFETs at all times. The MAX8535/MAX8536/MAX8585 determine the state of the monitored power supply by measuring the voltage drop across the external MOSFETs. With two external MOSFETs, the equation becomes:

$$VD_{TOTAL} = R_{DS(ON)1} \times I_{LOAD} + R_{DS(ON)2} \times I_{LOAD}$$

Selecting a MOSFET with a low R<sub>DS(ON)</sub> allows more current to flow through the MOSFETs before the MAX8535/MAX8536/MAX8585 detect reverse-current (I<sub>REVERSE</sub>) and forward-current (I<sub>FORWARD</sub>) conditions.

## Using a Single MOSFET

Single MOSFETs can be used if the OVP function is not needed. Connect the source of the MOSFET to V<sub>CC</sub> and the drain of the MOSFET to CS.

## Layout Guidelines

Keep all traces as short as possible and maximize the high-current trace width to reduce the effect of undesirable parasitic inductance. The MOSFET generates a fair amount of heat because of the high currents involved. In order to dissipate the heat generated by the MOSFET, make the power traces very wide with a large amount of copper area, and place the MAX8535/MAX8536/MAX8585 as close as possible to the drain of the external MOSFET. A more efficient way to achieve good power dissipation on a surface-mount package is to lay out two copper pads directly under the MOSFET package on both sides of the board. Connect the two pads to the ground plane through vias and use enlarged copper mounting pads on the topside of the board. Use a ground plane to minimize impedance and inductance. Refer to the MAX8535 Evaluation Kit data sheet for an example of a PC board layout.

In addition to the usual high-power considerations, bypassing prevent false faults by:

- 1) Bypass V<sub>CC</sub> with a 0.1 $\mu$ F capacitor to ground and bypassing CS with a 1nF capacitor to ground.
- 2) Making the traces connecting UVP and OVP as short as possible.
- 3) Kelvin connecting V<sub>CC</sub> and CS to the external MOSFET.



# ORing MOSFET Controllers with Fastest Fault Isolation for Redundant Power Supplies

## Typical Application Circuits

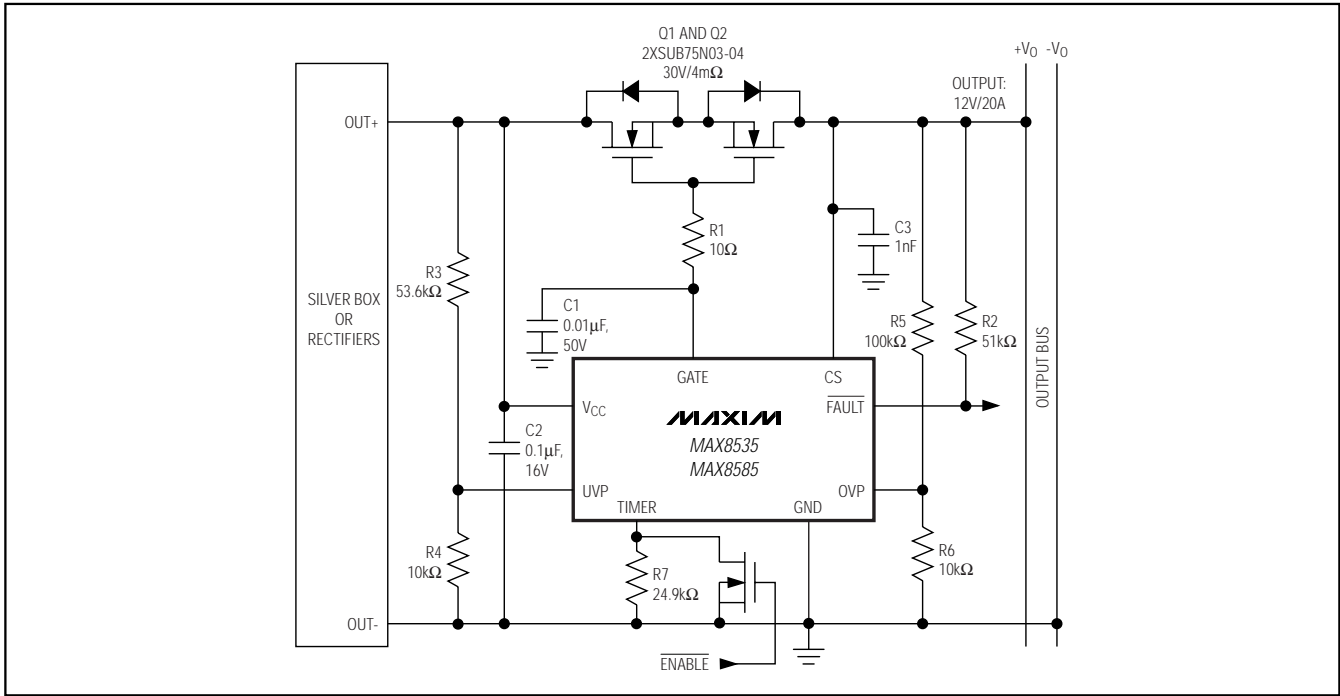

Figure 3. Typical Application Circuit for 12V/20A Output with OVP and UVP

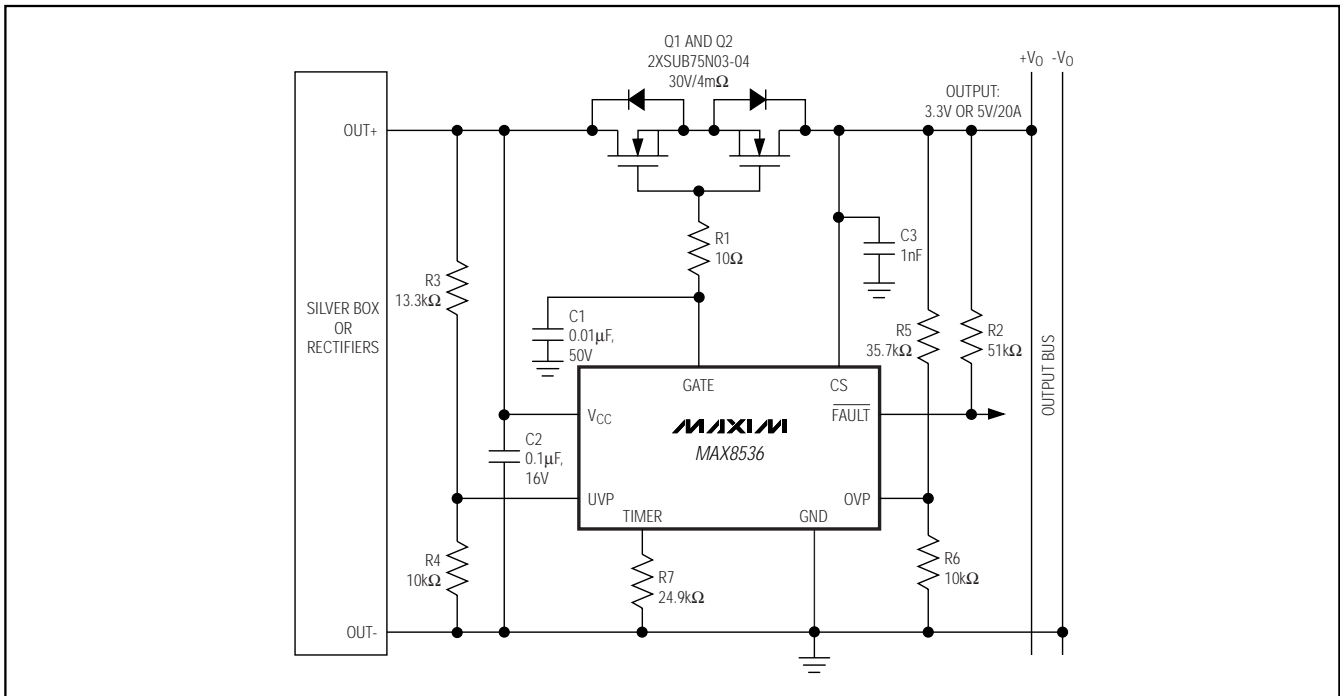

Figure 4. Typical Application Circuit for 3.3V or 5V/20A Output with OVP and UVP



# ORing MOSFET Controllers with Fastest Fault Isolation for Redundant Power Supplies

MAX8535/MAX8536/MAX8585

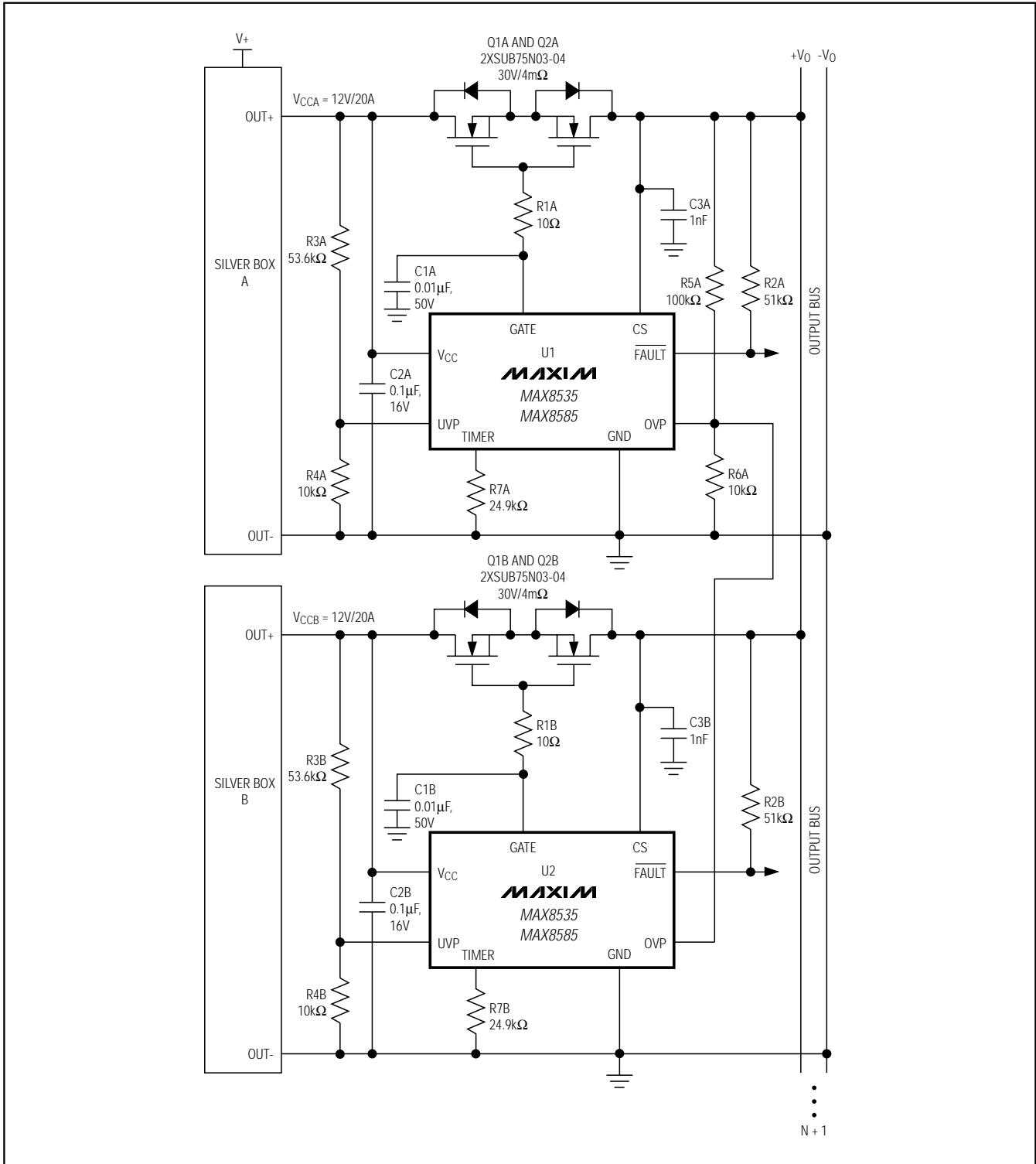
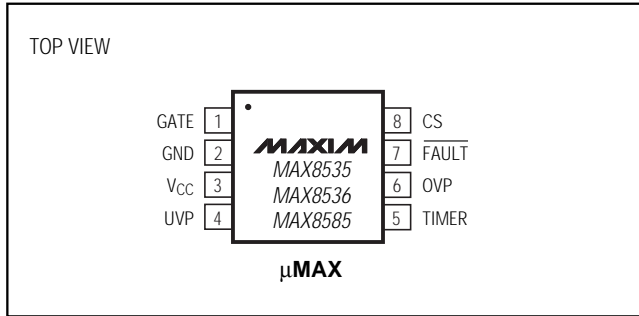

Figure 6. N + 1 Redundant Power System Connections

# ORing MOSFET Controllers with Fastest Fault Isolation for Redundant Power Supplies

## Pin Configuration



## Chip Information

TRANSISTOR COUNT: 3011  
PROCESS: BICMOS

MAX8535/MAX8536/MAX8585

# ORing MOSFET Controllers with Fastest Fault Isolation for Redundant Power Supplies

## Package Information

(The package drawing(s) in this data sheet may not reflect the most current specifications. For the latest package outline information, go to [www.maxim-ic.com/packages](http://www.maxim-ic.com/packages).)

DIM	INCHES		MILLIMETERS	
	MIN	MAX	MIN	MAX
A	-	0.043	-	1.10
A1	0.002	0.006	0.05	0.15
A2	0.030	0.037	0.75	0.95
b	0.010	0.014	0.25	0.36
c	0.005	0.007	0.13	0.18
D	0.116	0.120	2.95	3.05
e	0.0256 BSC		0.65 BSC	
E	0.116	0.120	2.95	3.05
H	0.188	0.198	4.78	5.03
L	0.016	0.026	0.41	0.66
α	0°	6°	0°	6°
S	0.0207 BSC		0.5250 BSC	

**NOTES:**  
 1. D&E DO NOT INCLUDE MOLD FLASH.  
 2. MOLD FLASH OR PROTRUSIONS NOT TO EXCEED 0.15MM (.006").  
 3. CONTROLLING DIMENSION: MILLIMETERS.  
 4. MEETS JEDEC MO-187C-AA.

**DALLAS SEMICONDUCTOR** **MAXIM**  
 PROPRIETARY INFORMATION  
 TITLE: PACKAGE OUTLINE, 8L uMAX/uSOP  
 APPROVAL: \_\_\_\_\_ DOCUMENT CONTROL NO. 21-0036 REV. J 1/1

8LUMAXD.EPS

Maxim cannot assume responsibility for use of any circuitry other than circuitry entirely embodied in a Maxim product. No circuit patent licenses are implied. Maxim reserves the right to change the circuitry and specifications without notice at any time.

20 \_\_\_\_\_ Maxim Integrated Products, 120 San Gabriel Drive, Sunnyvale, CA 94086 408-737-7600

## Looking for pricing, stock, or lifecycle information?

Click below to explore more details on WIN SOURCE:

 [View MAX8535EUA-T on WIN SOURCE](#)

 [Maxim Integrated](#) Information

## Optimize Your Supply Chain with WIN SOURCE Solutions

-  Global Sourcing Solution
-  Obsolete Management
-  Cost Control Management
-  Shortage Management
-  Alternative Solution
-  Excess Inventory Management