



**THE DATASHEET OF
MAX7705CSA-T**



MAXIM

μ P Power-Supply Monitor with Reset

MAX7705

General Description

In applications with microprocessors (μ Ps) that have a **RESET** input, the MAX7705 is functionally and socket compatible with the TL7705, but requires **no external components**. It provides power-supply glitch immunity and a guaranteed power-up reset delay, while typically consuming 1/27th the power from a +5V supply.

The MAX7705 monitors the power supply in μ P and digital systems. The **RESET** output is valid for V_{CC} down to 1V. The device offers excellent circuit reliability and low cost by eliminating external components and adjustments.

A system reset is provided during power-up, power-down, and brownout conditions. When V_{CC} is below the reset threshold, **RESET** is low and holds the μ P in reset. **RESET** will go high 280ms after V_{CC} rises above the reset threshold. The MAX7705 is available in 8-pin DIP and SO packages.

FEATURE	MAX7705	TL7705	
No. of External Components Required	0	3	
Operating Supply Current	+5V	65 μ A	1.8mA
	+3V	35 μ A	1.8mA
Power-Supply Glitch Immunity	Yes	No	
Guaranteed Minimum Reset Delay	Yes	No	

Applications

Minimum Component Count, Low-Cost Processor Systems

Pin Configuration

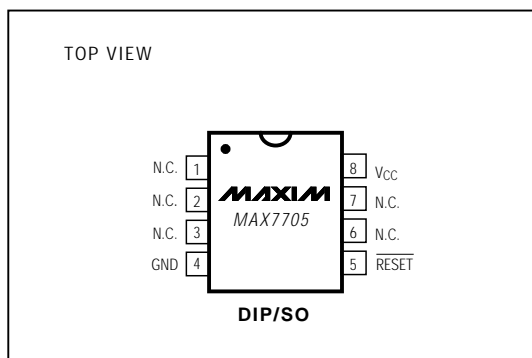

Features

- ◆ No External Components
- ◆ Low Cost
- ◆ Precise Reset Threshold
- ◆ 280ms Power-On Reset Delay
- ◆ 8-Pin DIP and SO Packages

Ordering Information

PART	TEMP. RANGE	PIN-PACKAGE
MAX7705CPA	0°C to +70°C	8 Plastic DIP
MAX7705CSA	0°C to +70°C	8 SO
MAX7705C/D	0°C to +70°C	Dice*
MAX7705EPA	-40°C to +85°C	8 Plastic DIP
MAX7705ESA	-40°C to +85°C	8 SO

* Contact factory for dice specifications.

Typical Operating Circuit

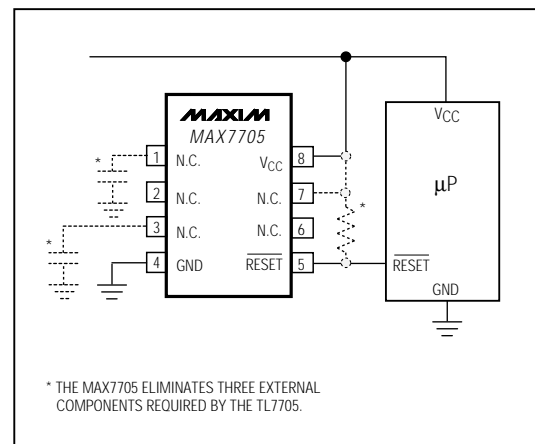

μP Power-Supply Monitor with Reset

MAX7705

ABSOLUTE MAXIMUM RATINGS

Terminal Voltage (with respect to GND)

V_{CC}-0.3V to 6.0V

RESET-0.3V to (V_{CC} + 0.3V)

Input Current, V_{CC}20mA

Output Current, RESET20mA

Rate-of-Rise, V_{CC}100V/μs

Continuous Power Dissipation (T_A = +70°C)

Plastic DIP (derate 9.09mW/°C above +70°C)727mW

SO (derate 5.88mW/°C above +70°C)471mW

Operating Temperature Ranges:

MAX7705C_ _0°C to +70°C

MAX7705E_ _-40°C to +85°C

Storage Temperature Range-65°C to +160°C

Lead Temperature (soldering, 10sec)+300°C

Stresses beyond those listed under "Absolute Maximum Ratings" may cause permanent damage to the device. These are stress ratings only, and functional operation of the device at these or any other conditions beyond those indicated in the operational sections of the specifications is not implied. Exposure to absolute maximum rating conditions for extended periods may affect device reliability.

ELECTRICAL CHARACTERISTICS

(V_{CC} = full range, T_A = T_{MIN} to T_{MAX}, unless otherwise noted.)

PARAMETER	CONDITIONS	MIN	TYP	MAX	UNITS
V _{CC} Range	MAX7705C	1.0		5.5	V
	MAX7705E	1.2		5.5	
Supply Current	MAX7705C, V _{CC} < 5.5V		65	150	μA
	MAX7705E, V _{CC} < 5.5V		65	200	
RESET Threshold		4.50	4.65	4.75	V
V _{CC} to RESET Delay	V _{CC} = reset threshold max to reset threshold min		20		μs
Reset Active Timeout Period	V _{CC} = reset threshold max, V _{CC} rising	140	280	560	ms
RESET Output Voltage	I _{SINK} = 3.2mA, V _{CC} = reset threshold min			0.4	V
	I _{SINK} = 50μA, V _{CC} ≥ 1.0V, MAX7705C			0.3	
	I _{SINK} = 100μA, V _{CC} ≥ 1.2V, MAX7705E			0.4	
	I _{SOURCE} = 800μA, V _{CC} ≥ reset threshold max	V _{CC} - 1.5			

μP Power-Supply Monitor with Reset

Typical Operating Characteristics

(T_A = +25°C, unless otherwise noted.)

MAX7705

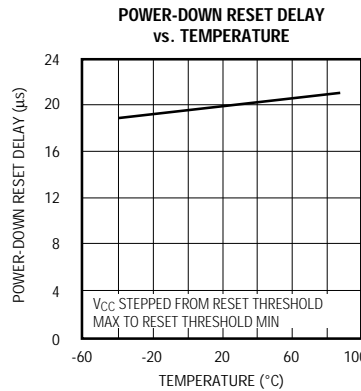
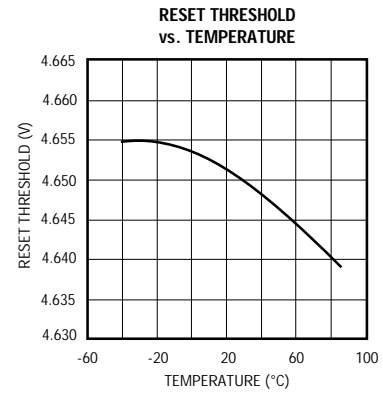
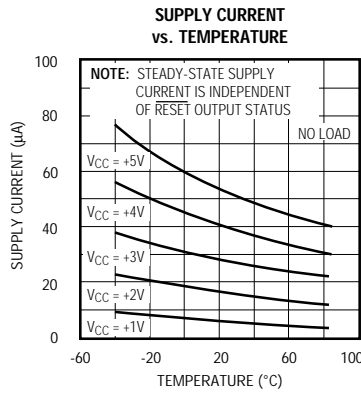
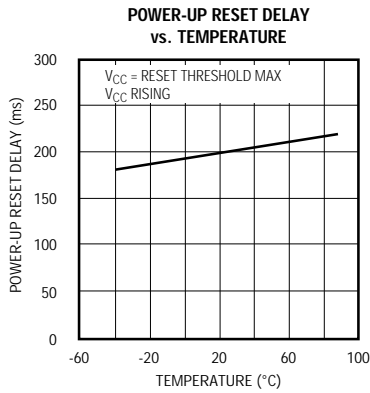

Pin Description

PIN	NAME	FUNCTION
1,2,3,6,7	N.C.	No Connection. There is no internal connection to these pins.
4	GND	Ground
5	RESET	Reset Output remains low while V _{CC} is below the reset threshold, and for 280ms after V _{CC} rises above the reset threshold.
8	V _{CC}	+5V Supply Voltage

μ P Power-Supply Monitor with Reset

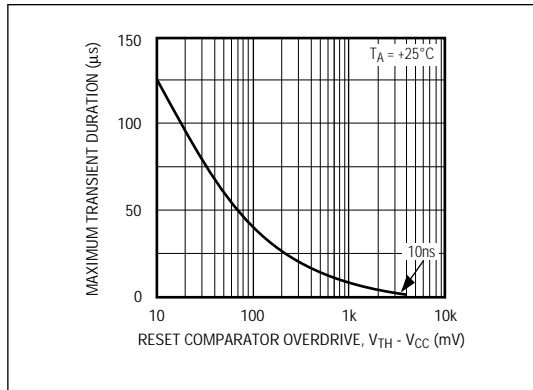

Figure 1. Maximum Transient Duration without Causing a Reset Pulse vs. Reset Comparator Overdrive

Applications Information

Replacing the TL7705 with a MAX7705 in an Existing Design

The MAX7705 has only three active pins: V_{CC} , GND, and **RESET**. When using a TL7705 with a μ P that has a **RESET** input, simply plug the MAX7705 into the same socket and omit the **RESET** pull-up resistor, reset timing capacitor, and reference bypass capacitor (see the *Typical Operating Circuit*).

The MAX7705 monitors the V_{CC} voltage and asserts reset whenever V_{CC} falls below the reset threshold. The reset power-up delay is created by an internal fixed oscillator. This delay is 100% tested and guaranteed over the full temperature range. The **RESET** output both sources and sinks current (see **RESET** Output Voltage in the *Electrical Characteristics*).

Negative-Going V_{CC} Transients

The MAX7705 asserts **RESET** during power-up, power-down, and brownout conditions. However, it is relatively immune to short-duration negative-going V_{CC} transients (glitches).

Figure 1 shows typical transient duration vs. reset comparator overdrive for which the MAX7705 does **not** generate a reset pulse. The graph was generated using a fast-edge, negative-going pulse applied to V_{CC} , starting 1.5V above the actual reset threshold and ending below the reset threshold by the magnitude indicated (reset comparator overdrive). It indicates the typical maxi-

imum pulse width a negative-going V_{CC} transient may have without causing a reset pulse to be issued. As the magnitude of the transient increases (goes farther below the reset threshold), the maximum allowable pulse width decreases. Typically, a V_{CC} transient that goes 100mV below the reset threshold and lasts 40 μ s or less will not cause a reset pulse to be issued.

A 0.1 μ F bypass capacitor mounted as close as possible to pin 2 (V_{CC}) provides additional transient immunity.

Ensuring a Valid **RESET** Output Down to $V_{CC} = 0V$

When V_{CC} falls below 1V, the MAX7705 **RESET** output no longer sinks current; it becomes high impedance. Therefore, high-impedance CMOS logic inputs connected to the **RESET** output can drift to indeterminate voltages. In most applications this presents no problem, as μ P and other circuitry is generally inoperative with V_{CC} below 1V. In applications where the **RESET** output must be valid down to 0V, adding a pull-down resistor to the **RESET** pin (as shown in Figure 2) will cause any stray leakage currents to flow to ground, holding **RESET** low. The resistance value of R1 is not critical. It should be about 100k Ω , which is large enough not to load **RESET** and small enough to pull **RESET** to ground.

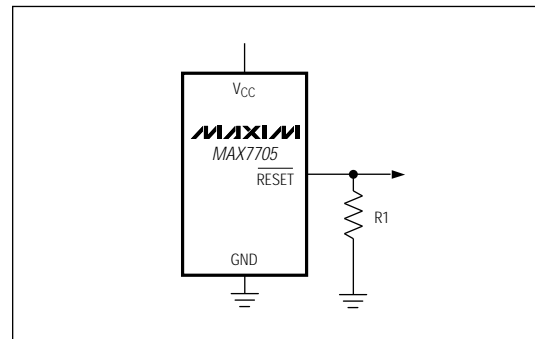

Figure 2. **RESET** Valid to $V_{CC} = \text{Ground}$ Circuit

μ P Power-Supply Monitor with Reset

Interfacing to μ Ps with Bidirectional Reset Inputs

μ Ps with bidirectional reset pins, such as Motorola's 68HC11 series, can contend with the MAX7705 reset output. If, for example, the MAX7705 **RESET** output is asserted high and the μ P wants to pull it low, an indeterminate logic level may result. To correct this, connect a 4.7k Ω resistor between the MAX7705 **RESET** output and the μ P reset I/O, as in Figure 3. Buffer the **RESET** signal to other system components.

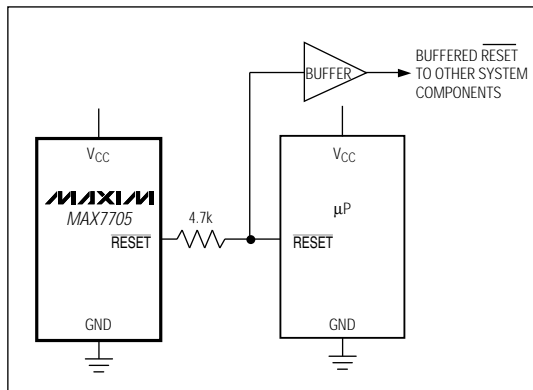
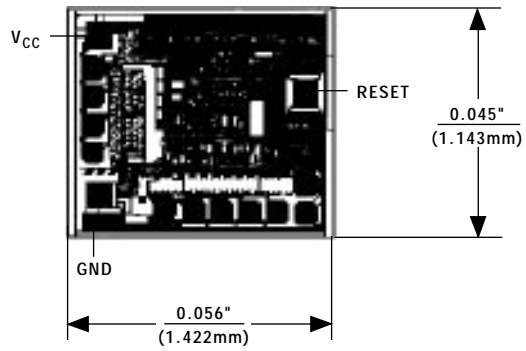

Figure 3. Interfacing to μ Ps with Bidirectional Reset I/O

Chip Topography



TRANSISTOR COUNT = 380;
SUBSTRATE CONNECTED TO V_{CC} .

MAX7705

μP Power-Supply Monitor with Reset

MAX7705

Package Information

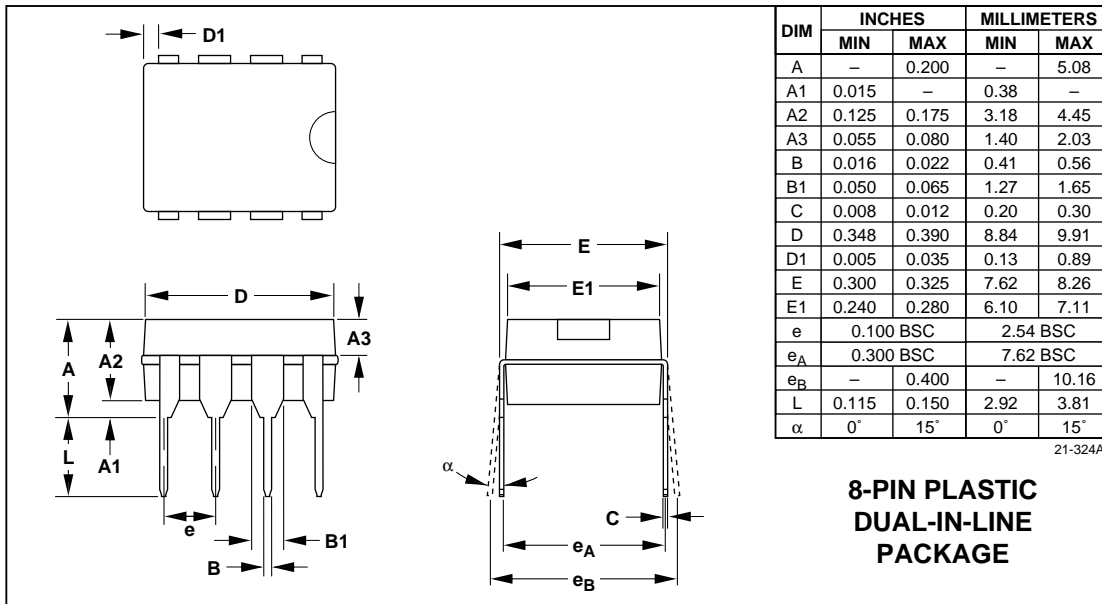

μ P Power-Supply Monitor with Reset

Package Information (continued)

MAX7705

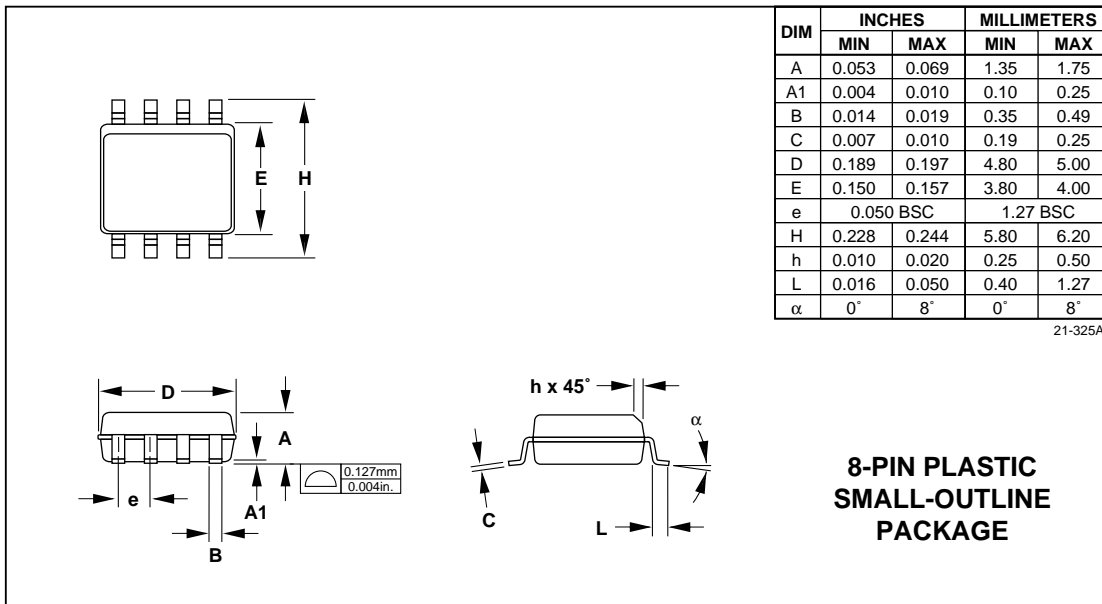

μP Power-Supply Monitor with Reset

MAX7705

μP Supervisory Circuits

Part Number	Nominal Reset Threshold (V)	Minimum Reset Pulse Width (ms)	Nominal Watchdog Timeout Period (sec)	Backup-Battery Switch	CE - Write Protect	Power-Fail Comparator	Manual-Reset Input	Watch-dog Output	Low-Line Output	Active-High Reset	Battery-On Output
MAX690A/692A	4.65/4.40	140	1.6	✓		✓					
MAX691A/693A	4.65/4.40	140/adj.	1.6/adj.	✓	✓/10ns	✓		✓	✓	✓	✓
MAX696	Adj.	35/adj.	1.6/adj.	✓		✓		✓	✓	✓	✓
MAX697	Adj.	35/adj.	1.6/adj.		✓	✓		✓	✓	✓	
MAX700	4.65/adj.	200	-				✓			✓	
MAX703/704	4.65/4.40	140	-	✓		✓	✓				
MAX705/706	4.65/4.40	140	1.6			✓	✓	✓			
MAX706P	2.63	140	1.6			✓	✓	✓		✓	
MAX706R/S/T	2.63/2.93/ 3.08	140	1.6			✓	✓	✓			
MAX707/708	4.65/4.40	140	-			✓	✓			✓	
MAX708R/S/T	2.63/2.93/ 3.08	140	-			✓	✓			✓	
MAX709L/M/ R/S/T	4.65/4.40/ 2.63/2.93/3.08	140	-								
MAX791	4.65	140	1	✓	✓/10ns	✓	✓	✓	✓	✓	✓
MAX792L/M/ R/S/T	4.65/4.40/ 2.63/2.93/3.08	140	1		✓/10ns	✓	✓	✓	✓	✓	
MAX800L/M	4.60/4.40	140	1.6/adj.	✓	✓/10ns	✓/±2%		✓	✓	✓	✓
MAX802L/M	4.60/4.40	140	1.6	✓		✓/±2%					
MAX805L	4.65	140	1.6	✓		✓				✓	
MAX813L	4.65	140	1.6			✓	✓	✓		✓	
MAX820L/M/ R/S/T	4.65/4.40/ 2.63/2.93/3.08	140	1		✓/10ns	✓/±2%	✓	✓	✓	✓	✓
MAX1232	4.37/4.62	250	0.15/0.60/1.2				✓				
MAX1259	-	-	-	✓		✓					

Maxim cannot assume responsibility for use of any circuitry other than circuitry entirely embodied in a Maxim product. No circuit patent licenses are implied. Maxim reserves the right to change the circuitry and specifications without notice at any time.

8 _____ Maxim Integrated Products, 120 San Gabriel Drive, Sunnyvale, CA 94086 (408) 737-7600

© 1993 Maxim Integrated Products

Printed USA

MAXIM is a registered trademark of Maxim Integrated Products.

Looking for pricing, stock, or lifecycle information?

Click below to explore more details on WIN SOURCE:

 [View MAX7705CSA-T on WIN SOURCE](#)

 [Maxim Integrated](#) Information

Optimize Your Supply Chain with WIN SOURCE Solutions

-  Global Sourcing Solution
-  Obsolete Management
-  Cost Control Management
-  Shortage Management
-  Alternative Solution
-  Excess Inventory Management