



**THE DATASHEET OF  
MAX7456EUI+T**



# MAX7456

## Single-Channel Monochrome On-Screen Display with Integrated EEPROM

### General Description

The MAX7456 single-channel monochrome on-screen display (OSD) generator lowers system cost by eliminating the need for an external video driver, sync separator, video switch, and EEPROM. The MAX7456 serves all national and international markets with 256 user-programmable characters in NTSC and PAL standards. The MAX7456 easily displays information such as company logo, custom graphics, time, and date with arbitrary characters and sizes. The MAX7456 is preloaded with 256 characters and pictographs and can be reprogrammed in-circuit using the SPI™ port.

The MAX7456 is available in a 28-pin TSSOP package and is fully specified over the extended (-40°C to +85°C) temperature range.

### Applications

Security Switching Systems  
 Security Cameras  
 Industrial Applications  
 In-Cabin Entertainment  
 Consumer Electronics

**Pin Configuration appears at end of data sheet.**

*SPI is a trademark of Motorola, Inc.*

### Features

- ◆ 256 User-Defined Characters or Pictographs in Integrated EEPROM
- ◆ 12 x 18 Pixel Character Size
- ◆ Blinking, Inverse, and Background Control Character Attributes
- ◆ Selectable Brightness by Row
- ◆ Displays Up to 16 Rows x 30 Characters
- ◆ Sag Compensation On Video-Driver Output
- ◆ LOS, VSYNC, HSYNC, and Clock Outputs
- ◆ Internal Sync Generator
- ◆ NTSC and PAL Compatible
- ◆ SPI-Compatible Serial Interface
- ◆ Delivered with Preprogrammed Character Set

### Ordering Information

PART	PIN-PACKAGE	LANGUAGE
MAX7456EUI+	28 TSSOP-EP*	English/ Japanese

\*EP = Exposed pad.

+ Denotes a lead-free/RoHS-compliant package.

**Note:** This device is specified over the -40°C to +85°C operating temperature range.

### Simplified Functional Diagram

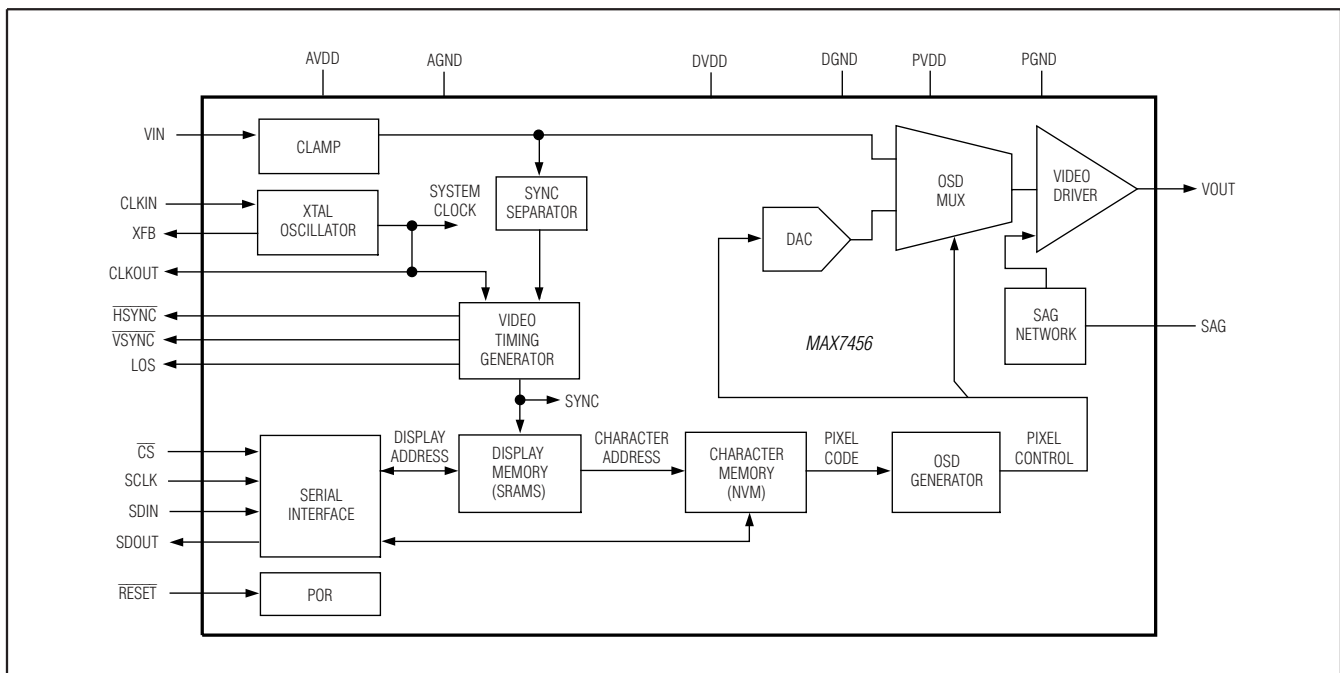

For pricing, delivery, and ordering information, please contact Maxim Direct at 1-888-629-4642, or visit Maxim's website at [www.maximintegrated.com](http://www.maximintegrated.com).

# MAX7456

## Single-Channel Monochrome On-Screen Display with Integrated EEPROM

### ABSOLUTE MAXIMUM RATINGS

AVDD to AGND .....	-0.3V to +6V	CLKIN, CLKOUT, XFB to DGND .....	-0.3V to (V <sub>DVDD</sub> + 0.3V)
DVDD to DGND .....	-0.3V to +6V	SDIN, SCLK, $\overline{\text{CS}}$ , SDO to DGND .....	-0.3V to (V <sub>DVDD</sub> + 0.3V)
PVDD to PGND .....	-0.3V to +6V	Maximum Continuous Current into V <sub>OUT</sub> .....	±100mA
AGND to DGND .....	-0.3V to +0.3V	Continuous Power Dissipation (T <sub>A</sub> = +70°C)	
AGND to PGND .....	-0.3V to +0.3V	28-Pin TSSOP (derate 27mW/°C above +70°C) .....	2162mW*
DGND to PGND .....	-0.3V to +0.3V	Operating Temperature Range .....	-40°C to +85°C
VIN, VOUT, SAG to AGND .....	-0.3V to (V <sub>AVDD</sub> + 0.3V)	Junction Temperature .....	+150°C
HSYNC, VSYNC, LOS to AGND .....	-0.3V to +6V	Storage Temperature Range .....	-60°C to +150°C
RESET to AGND .....	-0.3V to (V <sub>AVDD</sub> + 0.3V)	Lead Temperature (soldering, 10s) .....	+300°C

\* As per JEDEC51 Standard (Multilayer Board).

Stresses beyond those listed under "Absolute Maximum Ratings" may cause permanent damage to the device. These are stress ratings only, and functional operation of the device at these or any other conditions beyond those indicated in the operational sections of the specifications is not implied. Exposure to absolute maximum rating conditions for extended periods may affect device reliability.

### ELECTRICAL CHARACTERISTICS

(V<sub>AVDD</sub> = +4.75V to +5.25V, V<sub>DVDD</sub> = +4.75V to +5.25V, V<sub>PVDD</sub> = +4.75V to +5.25V, T<sub>A</sub> = T<sub>MIN</sub> to T<sub>MAX</sub>. Typical values are at V<sub>AVDD</sub> = V<sub>DVDD</sub> = V<sub>PVDD</sub> = +5V, T<sub>A</sub> = +25°C, unless otherwise noted.) (Note 1)

PARAMETER	SYMBOL	CONDITIONS	MIN	TYP	MAX	UNITS
<b>POWER SUPPLIES</b>						
Analog Supply Voltage	V <sub>AVDD</sub>		4.75	5	5.25	V
Digital Supply Voltage	V <sub>DVDD</sub>		4.75	5	5.25	V
Driver Supply Voltage	V <sub>PVDD</sub>		4.75	5	5.25	V
Analog Supply Current	I <sub>AVDD</sub>	V <sub>IN</sub> = 1V <sub>P-P</sub> (100% white flat field signal), V <sub>OUT</sub> load, R <sub>L</sub> = 150Ω		24	35	mA
Digital Supply Current	I <sub>DVDD</sub>	V <sub>IN</sub> = 1V <sub>P-P</sub> (100% white flat field signal), V <sub>OUT</sub> load, R <sub>L</sub> = 150Ω		25	30	mA
Driver Supply Current	I <sub>PVDD</sub>	V <sub>IN</sub> = 1V <sub>P-P</sub> (100% white flat field signal), V <sub>OUT</sub> load, R <sub>L</sub> = 150Ω		58	80	mA
<b>NONVOLATILE MEMORY</b>						
Data Retention		T <sub>A</sub> = +25°C		100		Years
Endurance		T <sub>A</sub> = +25°C		100,000		Stores
<b>DIGITAL INPUTS (<math>\overline{\text{CS}}</math>, SDIN, <math>\overline{\text{RESET}}</math>, SCLK)</b>						
Input High Voltage	V <sub>IH</sub>		2.0			V
Input Low Voltage	V <sub>IL</sub>				0.8	V
Input Hysteresis	V <sub>HYS</sub>			50		mV
Input Leakage Current		V <sub>IN</sub> = 0 or V <sub>DVDD</sub>			±10	μA
Input Capacitance	C <sub>IN</sub>			5		pF
<b>DIGITAL OUTPUTS (SDOUT, CLKOUT, VSYNC, HSYNC, LOS)</b>						
Output High Voltage	V <sub>OH</sub>	I <sub>SOURCE</sub> = 4mA (SDOUT, CLKOUT)	2.4			V
Output Low Voltage	V <sub>OL</sub>	I <sub>SINK</sub> = 4mA			0.45	V
Tri-State Leakage Current		SDOUT, $\overline{\text{CS}}$ = V <sub>DVDD</sub>			±10	μA

# MAX7456

## Single-Channel Monochrome On-Screen Display with Integrated EEPROM

### ELECTRICAL CHARACTERISTICS (continued)

( $V_{AVDD} = +4.75V$  to  $+5.25V$ ,  $V_{DVDD} = +4.75V$  to  $+5.25V$ ,  $V_{PVDD} = +4.75V$  to  $+5.25V$ ,  $T_A = T_{MIN}$  to  $T_{MAX}$ . Typical values are at  $V_{AVDD} = V_{DVDD} = V_{PVDD} = +5V$ ,  $T_A = +25^\circ C$ , unless otherwise noted.) (Note 1)

PARAMETER	SYMBOL	CONDITIONS	MIN	TYP	MAX	UNITS
<b>CLOCK INPUT (CLKIN)</b>						
Clock Frequency				27		MHz
Clock-Pulse High			14			ns
Clock-Pulse Low			14			ns
Input High Voltage			0.7 x $V_{DVDD}$			V
Input Low Voltage					0.3 x $V_{DVDD}$	V
Input Leakage Current		$V_{IN} = 0V$ or $V_{DVDD}$			$\pm 50$	$\mu A$
<b>CLOCK OUTPUT (CLKOUT)</b>						
Duty Cycle		5pF and 10k $\Omega$ to DGND	40	50	60	%
Rise Time		5pF and 10k $\Omega$ to DGND		3		ns
Fall Time		5pF and 10k $\Omega$ to DGND		3		ns
<b>VIDEO CHARACTERISTICS</b>						
DC Power-Supply Rejection		$V_{AVDD} = V_{DVDD} = V_{PVDD} = 5V$ ; $V_{IN} = 1V_{P-P}$ , measured at VOUT		40		dB
AC Power-Supply Rejection		$V_{AVDD} = V_{DVDD} = V_{PVDD} = 5V$ ; $V_{IN} = 1V_{P-P}$ , measured at VOUT; $f = 5MHz$ ; power-supply ripple = 0.2V $_{P-P}$		30		dB
Short-Circuit Current		VOUT to PGND			230	mA
Line-Time Distortion	LTD	Figures 1a, 1b			0.5	%
Output Impedance	ZOUT	Figures 1a, 1b		0.2		$\Omega$
Gain		Figures 1a, 1b	1.89	2.0	2.11	V/V
Black Level		At VOUT, Figures 1a, 1b			AGND + 1.5	V
Input-Voltage Operating Range	$V_{IN}$	Figures 1a, 3 (Note 2)	0.5		1.2	V $_{P-P}$
Input-Voltage Sync Detection Range	$V_{INSD}$	Figures 1a, 3 (Note 3)	0.5		2.0	V $_{P-P}$
Maximum Output-Voltage Swing	VOUT	Figures 1a, 1b	2.4			V $_{P-P}$
Output-Voltage Sync Tip Level				0.7		V
Large Signal Bandwidth (0.2dB)	BW	$V_{OUT} = 2V_{P-P}$ , Figures 1a, 1b		6		MHz
VIN to VOUT Delay				30		ns
Differential Gain	DG			0.5		%
Differential Phase	DP			0.5		Degrees
OSD White Level		VOUT 100% white level with respect to black level	1.25	1.33	1.45	V
Horizontal Pixel Jitter		Between consecutive horizontal lines		24		ns
Video Clamp Settling Time				32		Lines

# MAX7456

## Single-Channel Monochrome On-Screen Display with Integrated EEPROM

### ELECTRICAL CHARACTERISTICS (continued)

( $V_{AVDD} = +4.75V$  to  $+5.25V$ ,  $V_{DVDD} = +4.75V$  to  $+5.25V$ ,  $V_{PVDD} = +4.75V$  to  $+5.25V$ ,  $T_A = T_{MIN}$  to  $T_{MAX}$ . Typical values are at  $V_{AVDD} = V_{DVDD} = V_{PVDD} = +5V$ ,  $T_A = +25^\circ C$ , unless otherwise noted.) (Note 1)

PARAMETER	SYMBOL	CONDITIONS	MIN	TYP	MAX	UNITS
<b>OSD CHARACTERISTICS</b>						
OSD Rise Time		OSD insertion mux register OSDM[5,4,3] = 011b		60		ns
OSD Fall Time		OSD insertion mux register OSDM[5,4,3] = 011b		60		ns
OSD Insertion Mux Switch Time		OSD insertion mux register OSDM[2,1,0] = 011b		75		ns

### TIMING CHARACTERISTICS

( $V_{AVDD} = +4.75V$  to  $+5.25V$ ,  $V_{DVDD} = +4.75V$  to  $+5.25V$ ,  $V_{PVDD} = +4.75V$  to  $+5.25V$ ,  $T_A = T_{MIN}$  to  $T_{MAX}$ . Typical values are at  $V_{AVDD} = V_{DVDD} = V_{PVDD} = +5V$ ,  $T_A = +25^\circ C$ , unless otherwise noted.) (Note 1)

PARAMETER	SYMBOL	CONDITIONS	MIN	TYP	MAX	UNITS
<b>SPI TIMING</b>						
SCLK Period	$t_{CP}$		100			ns
SCLK Pulse-Width High	$t_{CH}$		40			ns
SCLK Pulse-Width Low	$t_{CL}$		40			ns
$\overline{CS}$ Fall to SCLK Rise Setup	$t_{CSS0}$		30			ns
$\overline{CS}$ Fall After SCLK Rise Hold	$t_{CSH0}$		0			ns
$\overline{CS}$ Rise to SCLK Setup	$t_{CSS1}$		30			ns
$\overline{CS}$ Rise After SCLK Hold	$t_{CSH1}$		0			ns
$\overline{CS}$ Pulse-Width High	$t_{CSW}$		100			ns
SDIN to SCLK Setup	$t_{DS}$		30			ns
SDIN to SCLK Hold	$t_{DH}$		0			ns
SDOUT Valid Before SCLK	$t_{DO1}$	20pF to ground	25			ns
SDOUT Valid After SCLK	$t_{DO2}$	20pF to ground	0			ns
$\overline{CS}$ High to SDOUT High Impedance	$t_{DO3}$	20pF to ground	300			ns
$\overline{CS}$ Low to SDOUT Logic Level	$t_{DO4}$	20pF to ground	20			ns
<b>HSYNC, VSYNC, AND LOS TIMING</b>						
LOS, $\overline{VSYNC}$ , and $\overline{HSYNC}$ Valid before CLKOUT Rising Edge	$t_{DOV}$	20pF to ground		30		ns
VOUT Sync to $\overline{VSYNC}$ Falling Edge Delay	$t_{VOUT-VSF}$	NTSC external sync mode, Figure 4		375		ns
		PAL external sync mode, Figure 6		400		

## Single-Channel Monochrome On-Screen Display with Integrated EEPROM

### TIMING CHARACTERISTICS (continued)

( $V_{AVDD} = +4.75V$  to  $+5.25V$ ,  $V_{DVDD} = +4.75V$  to  $+5.25V$ ,  $V_{PVDD} = +4.75V$  to  $+5.25V$ ,  $T_A = T_{MIN}$  to  $T_{MAX}$ . Typical values are at  $V_{AVDD} = V_{DVDD} = V_{PVDD} = +5V$ ,  $T_A = +25^\circ C$ , unless otherwise noted.) (Note 1)

PARAMETER	SYMBOL	CONDITIONS	MIN	TYP	MAX	UNITS
VOUT Sync to $\overline{VSYN\bar{C}}$ Rising Edge Delay	t <sub>VOUT-VSR</sub>	NTSC external sync mode, Figure 4		400		ns
		PAL external sync mode, Figure 6		425		
$\overline{VSYN\bar{C}}$ Falling Edge to VOUT Sync Delay	t <sub>VSF-VOUT</sub>	NTSC internal sync mode, Figure 5		40		ns
		PAL internal sync mode, Figure 7		45		
$\overline{VSYN\bar{C}}$ Rising Edge to VOUT Sync Delay	t <sub>VSR-VOUT</sub>	NTSC internal sync mode, Figure 5		32		ns
		PAL internal sync mode, Figure 7		30		
VOUT Sync to $\overline{HSYN\bar{C}}$ Falling Edge Delay	t <sub>VOUT-HSF</sub>	NTSC and PAL external sync mode, Figure 8		310		ns
VOUT Sync to $\overline{HSYN\bar{C}}$ Rising Edge Delay	t <sub>VOUT-HSR</sub>	NTSC and PAL external sync mode, Figure 8		325		ns
$\overline{HSYN\bar{C}}$ Falling Edge to VOUT Sync Delay	t <sub>HSF-VOUT</sub>	NTSC and PAL internal sync mode, Figure 9		115		ns
$\overline{HSYN\bar{C}}$ Rising Edge to VOUT Sync Delay	t <sub>HSR-VOUT</sub>	NTSC and PAL internal sync mode, Figure 9		115		ns
All Supplies High to $\overline{CS}$ Low	t <sub>PUD</sub>	Power-up delay		50		ms
NVM Write Busy	t <sub>NVW</sub>			12		ms

**Note 1:** See the standard test circuits of Figure 1.  $R_L = 75\Omega$ , unless otherwise specified. All digital input signals are timed from a voltage level of  $(V_{IH} + V_{IL}) / 2$ . All parameters are tested at  $T_A = +85^\circ C$  and values through temperature range are guaranteed by design.

**Note 2:** The input-voltage operating range is the input range over which the output signal parameters are guaranteed (Figure 3).

**Note 3:** The input-voltage sync detection range is the input composite video range over which an input sync signal is properly detected and the OSD signal appears at VOUT. However, the output voltage specifications are not guaranteed for input signals exceeding the maximum specified in the input operating voltage range (Figure 3).

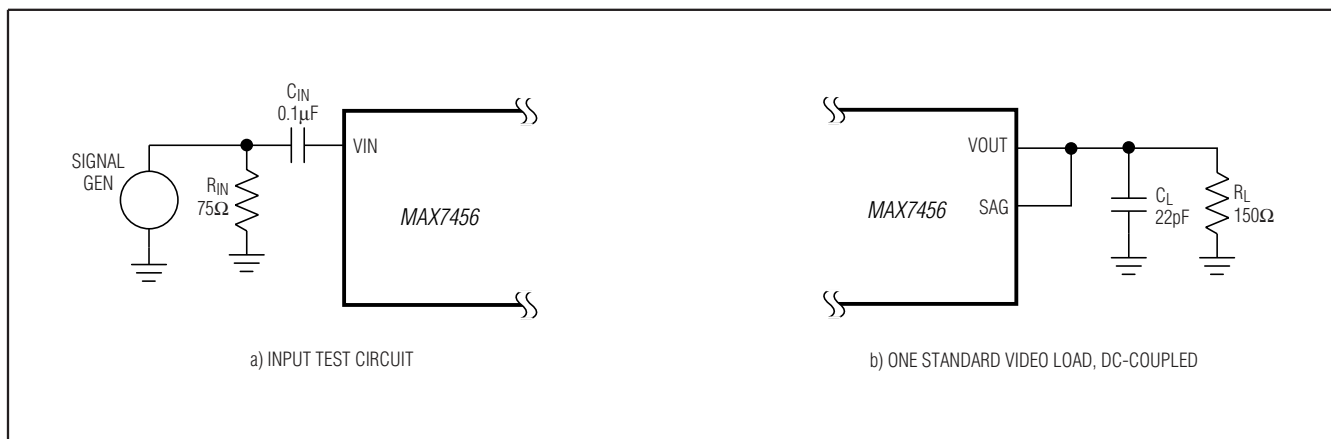

Figure 1. Standard Test Circuits

# MAX7456

## Single-Channel Monochrome On-Screen Display with Integrated EEPROM

### Typical Operating Characteristics

( $V_{AVDD} = +5V$ ,  $V_{DVDD} = +5V$ ,  $V_{PVDD} = +5V$ ,  $T_A = +25^\circ C$ , unless otherwise noted. See the *Typical Operating Circuit* of Figure 2, if applicable.)

IMAGE WITH ON-SCREEN GRAPHICS



100% COLOR BARS RESPONSE

MAX7456 toc02

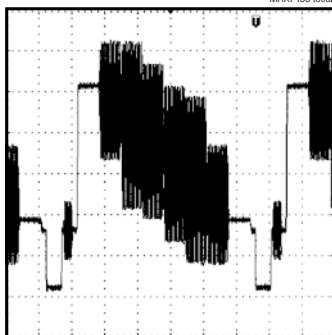

10µs/div

75% COLOR BARS VECTOR DIAGRAM

MAX7456 toc03

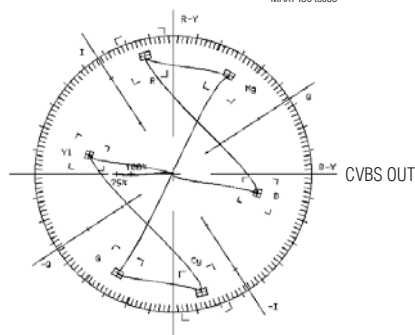

60% MULTIBURST RESPONSE

MAX7456 toc04

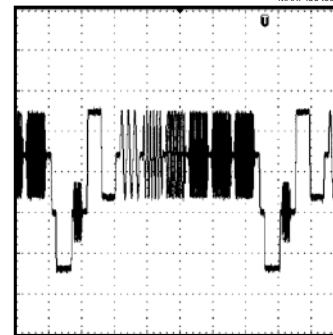

10µs/div

# MAX7456

## Single-Channel Monochrome On-Screen Display with Integrated EEPROM

### Typical Operating Characteristics (continued)

( $V_{AVDD} = +5V$ ,  $V_{DVDD} = +5V$ ,  $V_{PVDD} = +5V$ ,  $T_A = +25^\circ C$ , unless otherwise noted. See the *Typical Operating Circuit* of Figure 2, if applicable.)

100% SWEEP RESPONSE

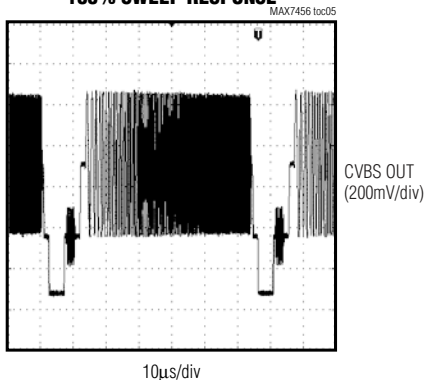

DIFFERENTIAL PHASE

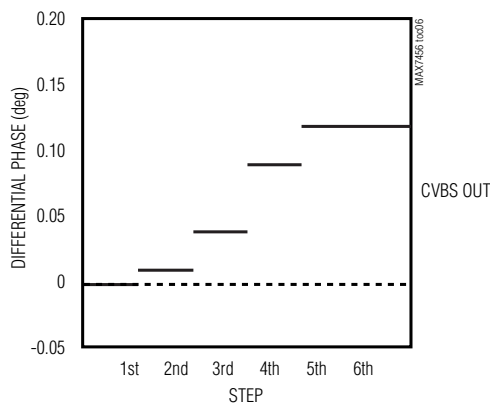

DIFFERENTIAL GAIN

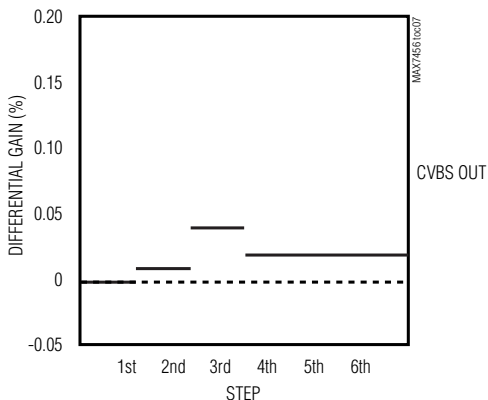

2T RESPONSE

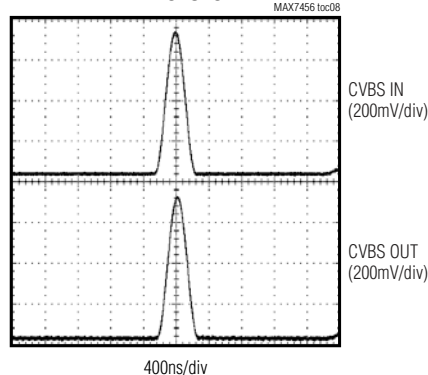

12.5T RESPONSE

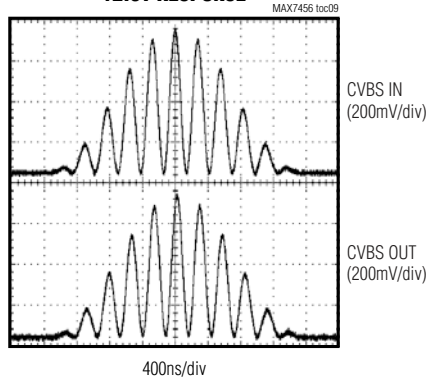

OSD OUTPUT 100% WHITE PIXEL

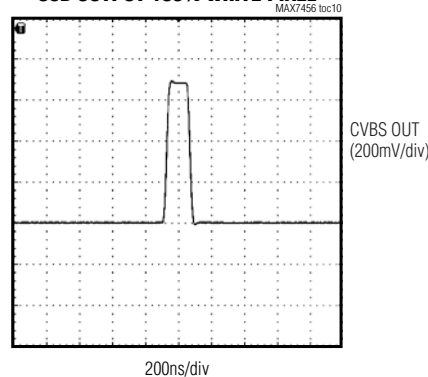

# MAX7456

## Single-Channel Monochrome On-Screen Display with Integrated EEPROM

### Typical Operating Characteristics (continued)

( $V_{AVDD} = +5V$ ,  $V_{DVDD} = +5V$ ,  $V_{PVDD} = +5V$ ,  $T_A = +25^\circ C$ , unless otherwise noted. See the *Typical Operating Circuit* of Figure 2, if applicable.)

**LINE-TIME DISTORTION**

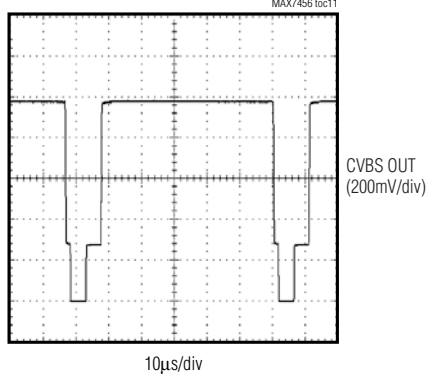

**H TIMING (EXTERNAL-SYNC MODE)**

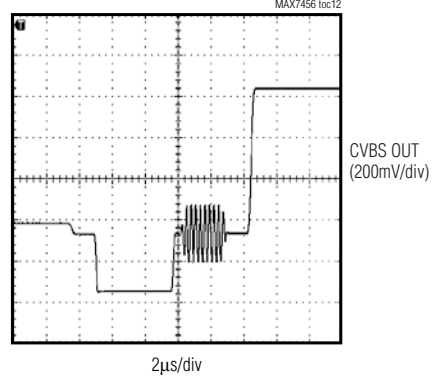

**H TIMING (INTERNAL-SYNC MODE)**

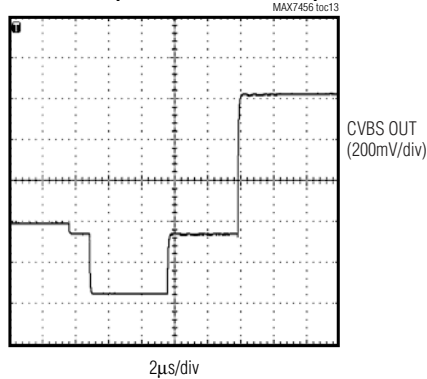

**LOSS-OF-SYNC (LOW TO HIGH)**

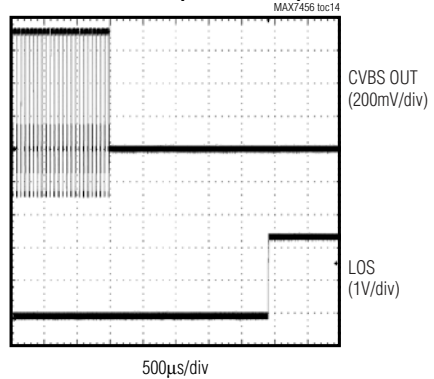

**LOSS-OF-SYNC (HIGH TO LOW)**

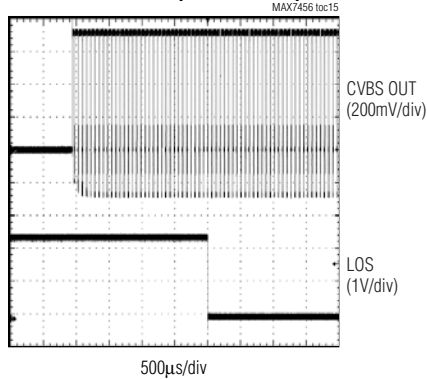

# MAX7456

## Single-Channel Monochrome On-Screen Display with Integrated EEPROM

### Pin Description

PIN	NAME	FUNCTION
1, 2, 13–16, 27, 28	N.C.	No Connection. Not internally connected.
3	DVDD	Digital Power-Supply Input. Bypass to DGND with a 0.1µF capacitor.
4	DGND	Digital Ground
5	CLKIN	Crystal Connection 1. Connect a parallel resonant, fundamental mode crystal between CLKIN and XFB for use as a crystal oscillator, or drive CLKIN directly with a 27MHz system reference clock.
6	XFB	Crystal Connection 2. Connect a parallel resonant, fundamental mode crystal between CLKIN and XFB for use as a crystal oscillator, or leave XFB unconnected when driving CLKIN with a 27MHz system reference clock.
7	CLKOUT	Clock Output. 27MHz logic-level output system clock.
8	$\overline{CS}$	Active-Low Chip-Select Input. SDOUT goes high impedance when $\overline{CS}$ is high.
9	SDIN	Serial Data Input. Data is clocked in at rising edge of SCLK.
10	SCLK	Serial Clock Input. Clocks data into SDIN and out of SDOUT. Duty cycle must be between 40% and 60%.
11	SDOUT	Serial Data Output. Data is clocked out at the falling edge of SCLK. High impedance when $\overline{CS}$ is high.
12	LOS	Loss-of-Sync Output (Open-Drain). LOS goes high when the VIN sync pulse is lost for 32 consecutive lines. LOS goes low when 32 consecutive valid sync pulses are received. Connect to a 1kΩ pullup resistor to DVDD or another positive supply voltage suitable for the receiving device.
17	$\overline{VSYN}$	Vertical Sync Output (Open-Drain). $\overline{VSYN}$ goes low following the video input's vertical sync interval. $\overline{VSYN}$ is either recovered from VIN or internally generated when in internal sync mode. Connect to a 1kΩ pullup resistor to DVDD or another positive supply voltage suitable for the receiving device.
18	$\overline{HSYN}$	Horizontal Sync Output (Open-Drain). $\overline{HSYN}$ goes low following the video input's horizontal sync interval. $\overline{HSYN}$ is either recovered from VIN or internally generated when in internal sync mode. Connect to a 1kΩ pullup resistor to DVDD or another positive supply voltage suitable for the receiving device.
19	$\overline{RESET}$	System Reset Input. The minimum $\overline{RESET}$ pulse width is 50ms. All SPI registers are reset to their default values after 100µs following the rising edge of $\overline{RESET}$ . These registers are not accessible for reading or writing during that time. The display memory is reset to its default value of 00H in all locations after 20µs following the rising edge of $\overline{RESET}$ .
20	AGND	Analog Ground
21	AVDD	Analog Power-Supply Input. Bypass to AGND with a 0.1µF capacitor.
22	VIN	PAL or NTSC CVBS Video Input
23	PGND	Driver Ground. Connect to AGND at a single point.
24	PVDD	Driver Power-Supply Input. Bypass to PGND with a 0.1µF capacitor.
25	SAG	Sag Correction Input. Connect to VOUT if not used. See Figure 1b.
26	VOUT	Video Output
—	EP	Exposed Pad. Internally connected to AGND. Connect EP to the AGND plane for improved heat dissipation. Do not use EP as the only ground connection.

# MAX7456

## Single-Channel Monochrome On-Screen Display with Integrated EEPROM

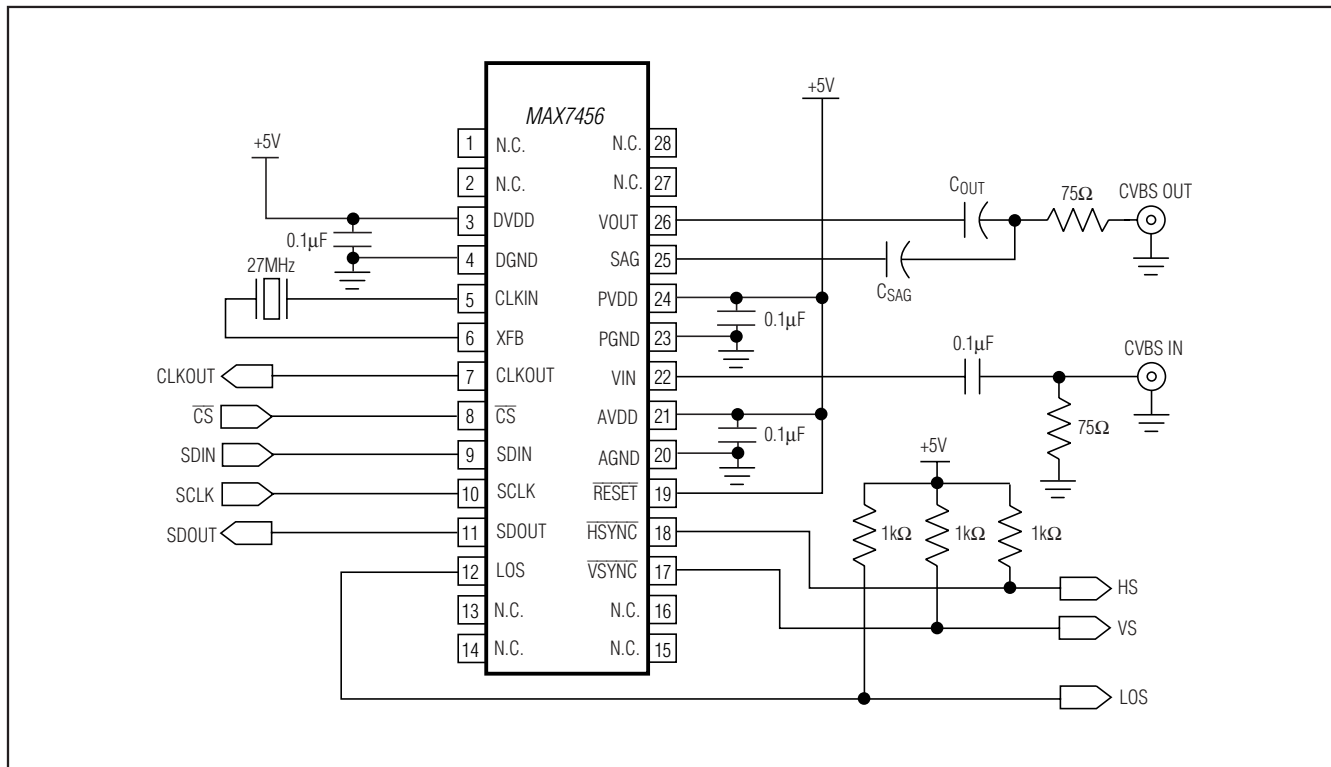

Figure 2. Typical Operating Circuit

### Detailed Description

The MAX7456 single-channel monochrome on-screen display (OSD) generator integrates all the functions needed to generate a user-defined OSD and insert it into the output signal. The MAX7456 accepts a composite NTSC or PAL video signal. The device includes an input clamp, sync separator, video timing generator, OSD insertion mux, nonvolatile character memory, display memory, OSD generator, crystal oscillator, an SPI-compatible interface to read/write the OSD data, and a video driver (see the *Simplified Functional Diagram*). Additionally, the MAX7456 provides vertical sync ( $\overline{\text{VSYNC}}$ ), horizontal sync (HSYNC), and loss-of sync (LOS) outputs for system synchronization. A clock output signal (CLKOUT) allows daisy-chaining of multiple devices.

See the *MAX7456 Register Description* section for an explanation of register notation use in this data sheet.

The 256 user-defined 12 x 18 pixel character set comes preloaded and is combined with the input video stream to generate a CVBS signal with OSD video output. A maximum of 256 12 x 18 pixel characters can be reprogrammed in the NVM. In NTSC mode, 13 rows x 30 characters are displayed. In PAL mode, 16 rows x 30 characters are displayed. When the input video signal is absent, the OSD image can still be displayed by using the MAX7456's internal video timing generator.

### Video Input

The MAX7456 accepts standard NTSC or PAL CVBS signals at VIN. The video signal input must be AC-coupled with a 0.1µF capacitor and is internally clamped. An input coupling capacitance of 0.1µF is required to guarantee the specified line-time distortion (LTD) and video clamp settling time. The video clamp settling time changes proportionally to the input coupling capacitance, and LTD changes inversely proportional to the capacitance.

## Single-Channel Monochrome On-Screen Display with Integrated EEPROM

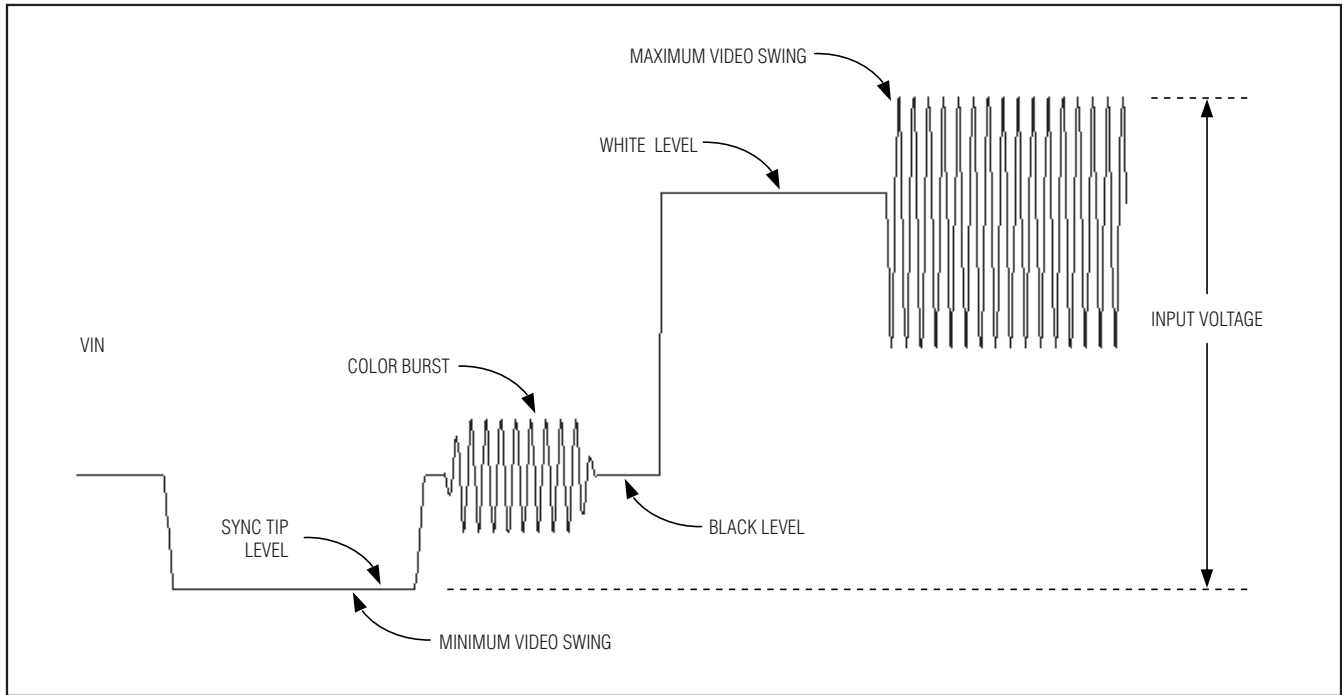

Figure 3. Definition of Terms

### Input Clamp

The MAX7456's clamp is a DC-restore circuit that uses the input coupling capacitor to correct any DC shift of the input signal, on a line-by-line basis, such that the sync tip at VIN is approximately 550mV. This establishes a DC level at VIN suitable for the on-chip sync detection and video processing functions. This circuitry also removes low-frequency noise such as 60Hz hum or other additive low-frequency noise.

### Sync Separator

The sync separator detects the composite sync pulses on the video input and extracts the timing information to generate  $\overline{\text{HSYNC}}$  and  $\overline{\text{VSYNC}}$ . It is also used for internal OSD synchronization and loss-of-sync (LOS) detection. LOS goes high if no sync signal is detected at VIN for 32 consecutive lines, and goes low if 32 consecutive horizontal sync signals are detected. During a LOS condition, when VM0[5] = 0 (Video Mode 0 register, bit 5), only the OSD appears at the VOUT. At this time, the input image is set to a gray level at VOUT as determined by VM1[6:4]. The behavior of all sync modes is shown in Table 1.

Table 1. Video Sync Modes

VIDEO MODE	VIN	$\overline{\text{VSYNC}}$	$\overline{\text{HSYNC}}$	LOS	VOUT
Auto Sync Select Mode VM0[5, 4] = 0x	Video	Active	Active	Low	VIN + OSD
	No input	Active	Active	High	OSD only
External Sync Select VM0[5, 4] = 10	Video	Active	Active	Low	VIN + OSD
	No input	Inactive (high)	Inactive (high)	High	DC
Internal Sync Select VM0[5, 4] = 11	Video	Active	Active	High	OSD only
	No input	Active	Active	High	OSD only

X = Don't care.

# MAX7456

## Single-Channel Monochrome On-Screen Display with Integrated EEPROM

### Video Timing Generator

The video timing generator is a digital circuit generating all internal and external ( $\overline{\text{VSYNC}}$  and  $\overline{\text{HSYNC}}$ ) timing signals.  $\overline{\text{VSYNC}}$  and  $\overline{\text{HSYNC}}$  can be synchronized to VIN, or run independently of any input when in internal sync mode. The video timing generator can generate NTSC or PAL timing using the same 27MHz crystal (see Figures 4–9).

### Crystal Oscillator

The internal crystal oscillator generates the system clock used by the video timing generator. The oscillator uses a 27MHz crystal or can be driven by an external 27MHz TTL clock at CLKIN. For external clock mode, connect the 27MHz TTL input clock to CLKIN and leave XFB unconnected.

### Display Memory (SRAM)

The display memory stores 480 character addresses that point to the characters stored in the NVM character memory. The content of the display memory is user-programmable through the SPI-compatible serial interface. The display-memory address corresponds to a fixed location on a monitor (see Figure 10). Momentary breakup of the OSD image can be prevented by writing to the display memory during the vertical blanking interval. This can be achieved by using  $\overline{\text{VSYNC}}$  as an interrupt to the host processor to initiate writing to the display memory.

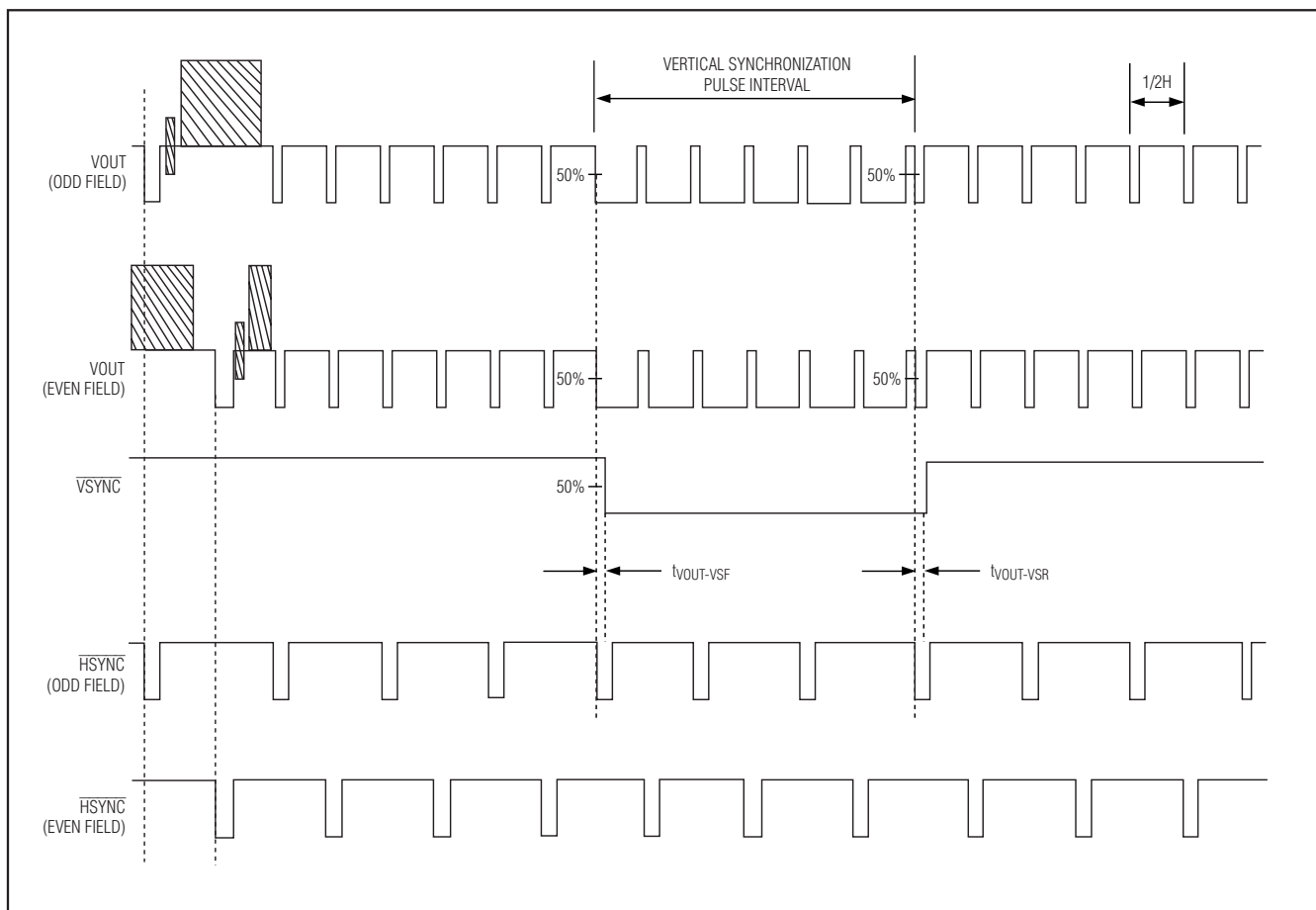

Figure 4. VOUT,  $\overline{\text{VSYNC}}$ , and  $\overline{\text{HSYNC}}$  Timing (NTSC, External Sync Mode)

# MAX7456

## Single-Channel Monochrome On-Screen Display with Integrated EEPROM

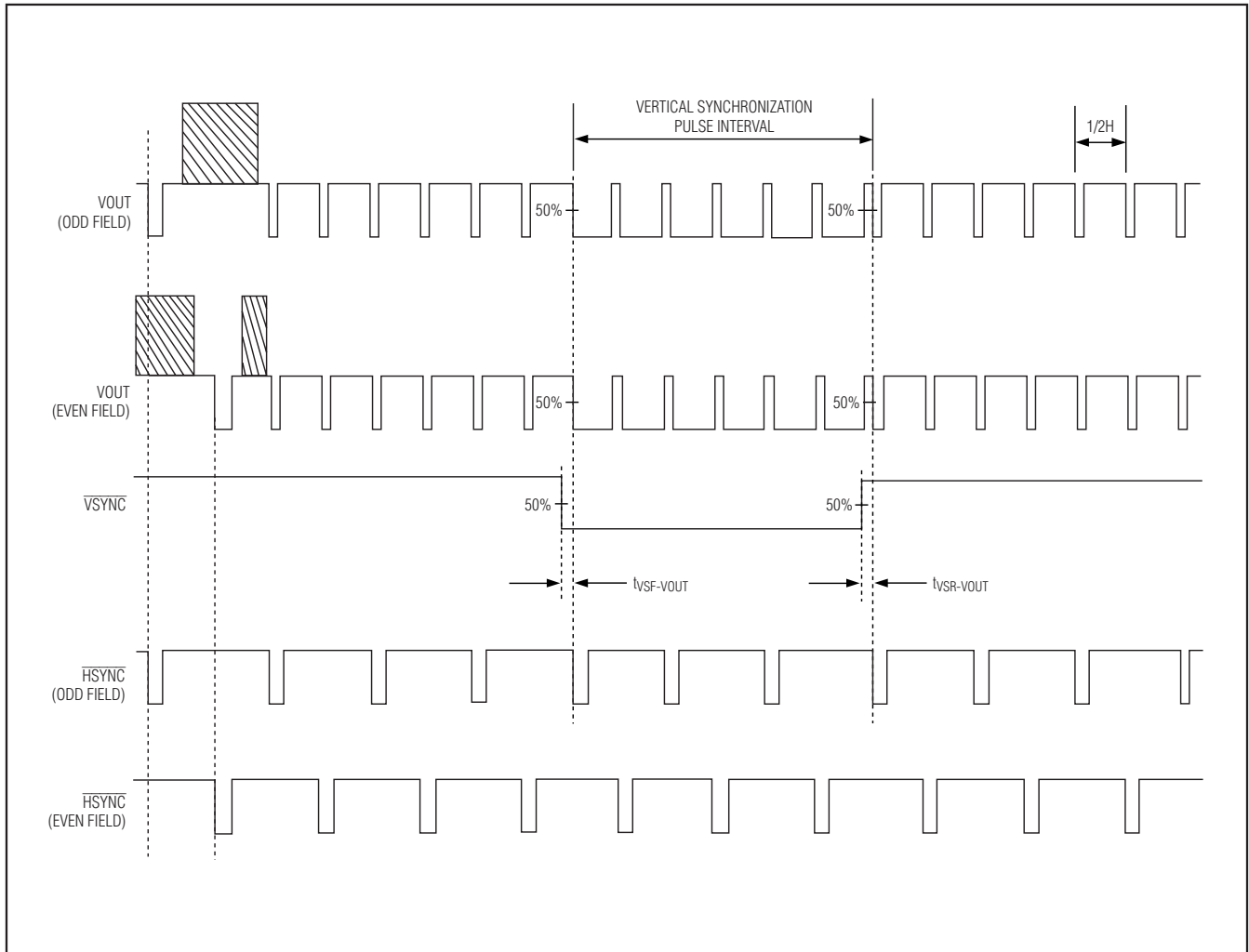

Figure 5. VOUT, VSYNC, and HSYNC Timing (NTSC, Internal Sync Mode)

# MAX7456

## Single-Channel Monochrome On-Screen Display with Integrated EEPROM

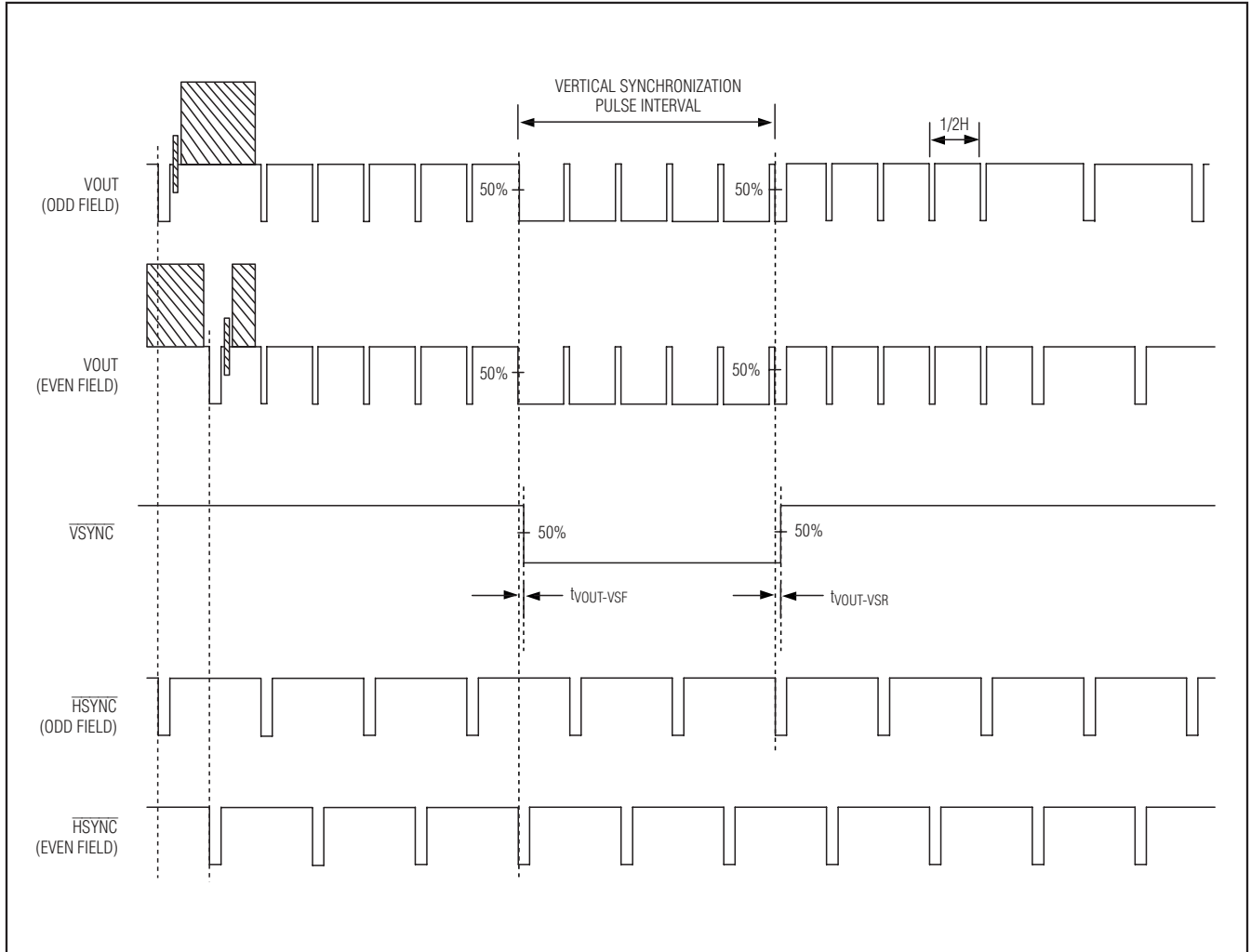

Figure 6. VOUT, VSYNC, and HSYNC Timing (PAL, External Sync Mode)

# MAX7456

## Single-Channel Monochrome On-Screen Display with Integrated EEPROM

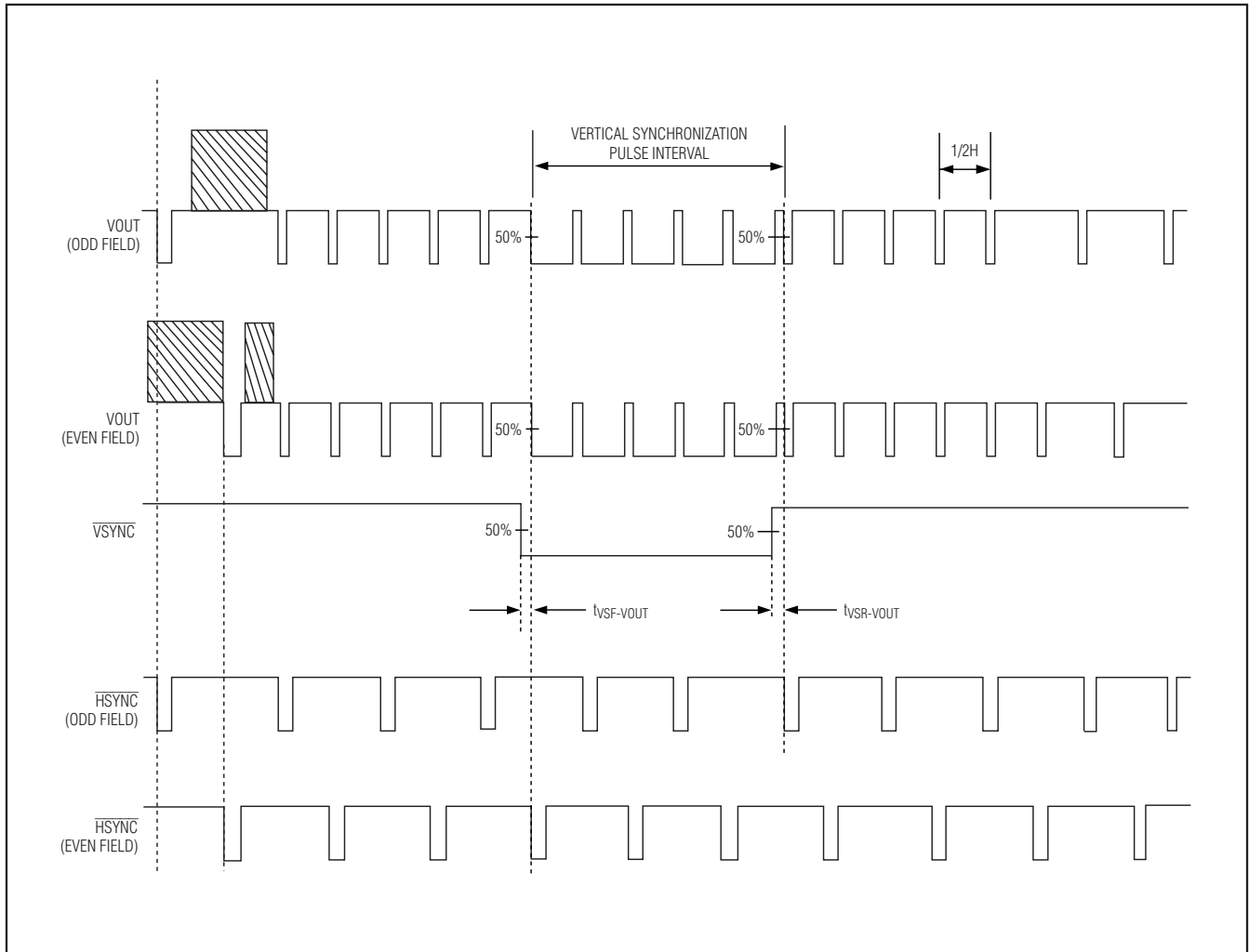

Figure 7. VOUT, VSYNC, and HSYNC Timing (PAL, Internal Sync Mode)

# MAX7456

## Single-Channel Monochrome On-Screen Display with Integrated EEPROM

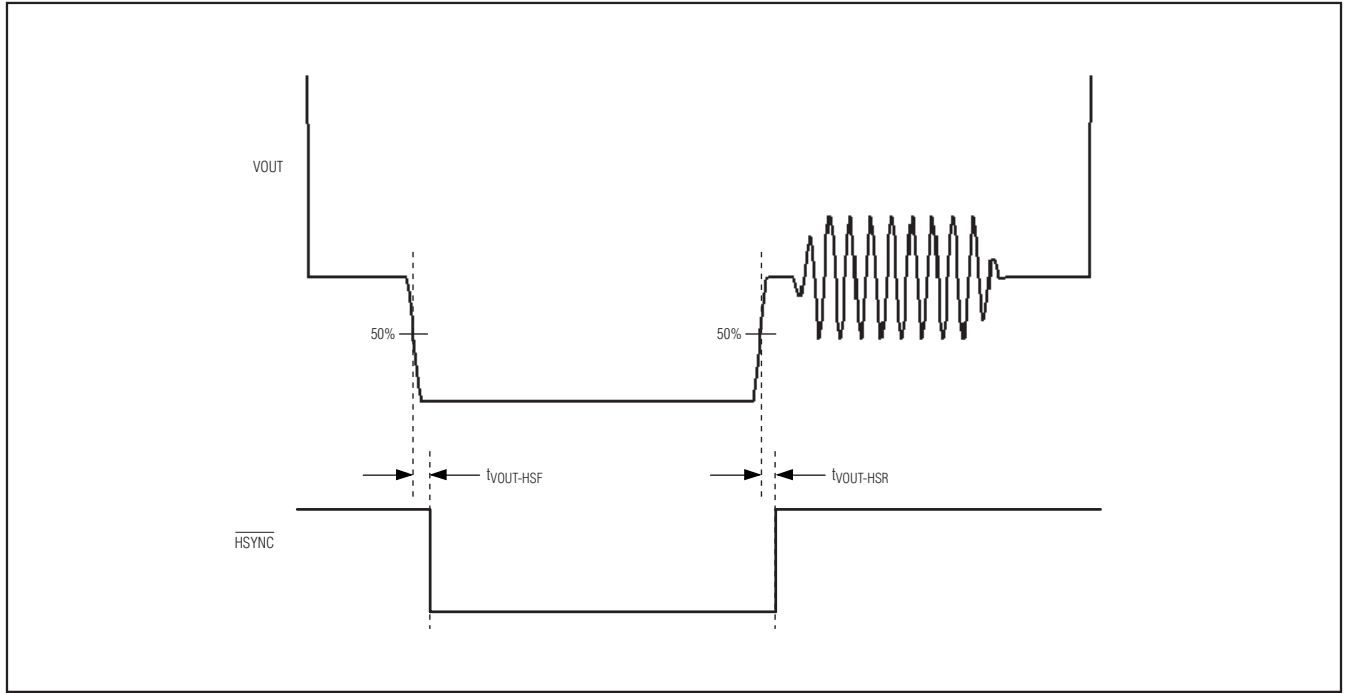

Figure 8. VOUT, and  $\overline{HSYNC}$  Horizontal Sync Timing (NTSC and PAL, External Sync Mode)

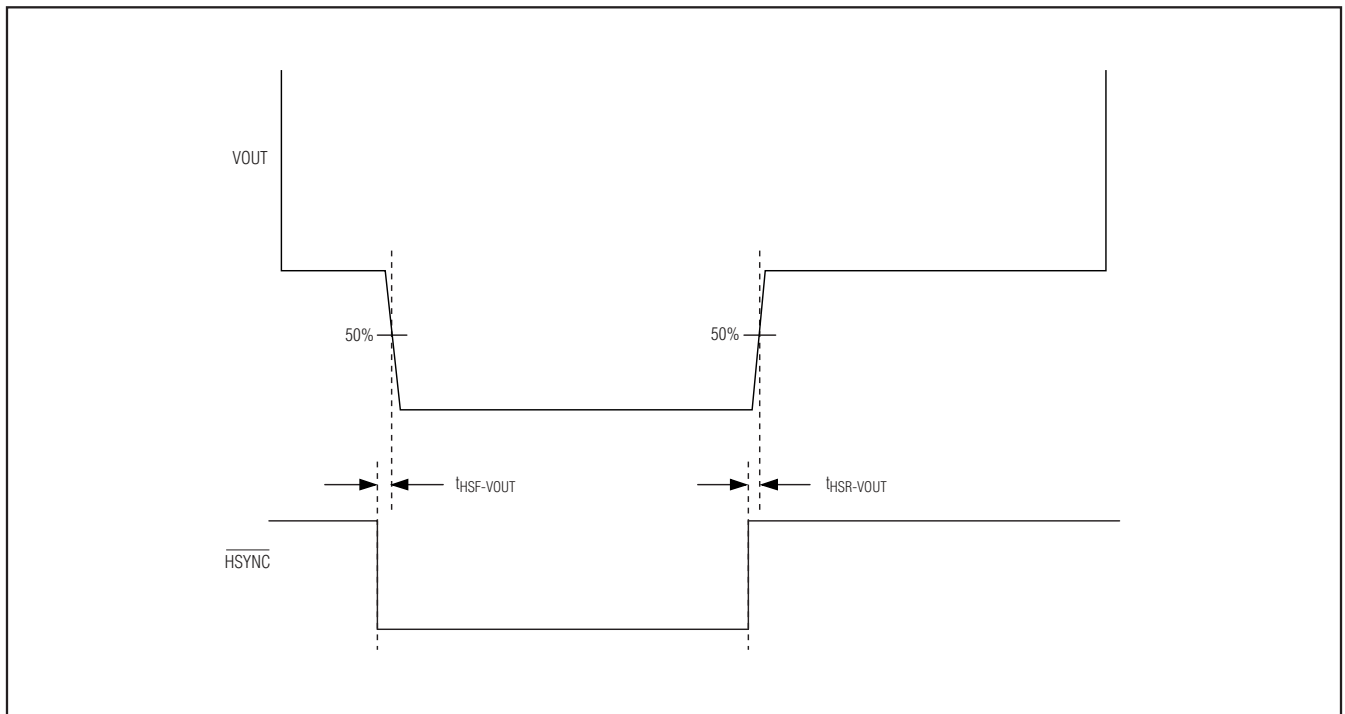

Figure 9. VOUT and  $\overline{HSYNC}$  Horizontal Sync Timing (NTSC and PAL, Internal Sync Mode)

## Single-Channel Monochrome On-Screen Display with Integrated EEPROM

### Character Memory (NVM)

The character memory is a 256-row x 64-byte wide nonvolatile memory (NVM) that stores the characters or graphic images, and is factory preloaded with the characters shown in Figure 12. The content of the character memory is user-programmable through the SPI-compatible serial interface. Each row contains the description of a single OSD character. Each character consists of 12 horizontal x 18 vertical pixels where each pixel is represented by 2 bits of data having three states: white, black, or transparent. Thus, each character requires 54 bytes of pixel data (Figure 11).

The NVM requires reading and writing a whole character (64 bytes) at a time. This is enabled by an additional

row of memory called the shadow RAM. The 64-byte temporary shadow RAM contains all the pixel data of a selected character (CMAH[7:0]) and is used as a buffer for read and write operations to the NVM (Figure 13). Accessing the NVM is always through the shadow RAM, and is thus a two-step process. To write a character to the NVM, the user first fills the shadow RAM using 54 8-bit SPI write operations, and then executes a single shadow RAM write command. Similarly, reading a character's pixel values requires first reading a character's pixel data into the shadow RAM, and then reading the desired pixel data from the shadow RAM to the SPI port.

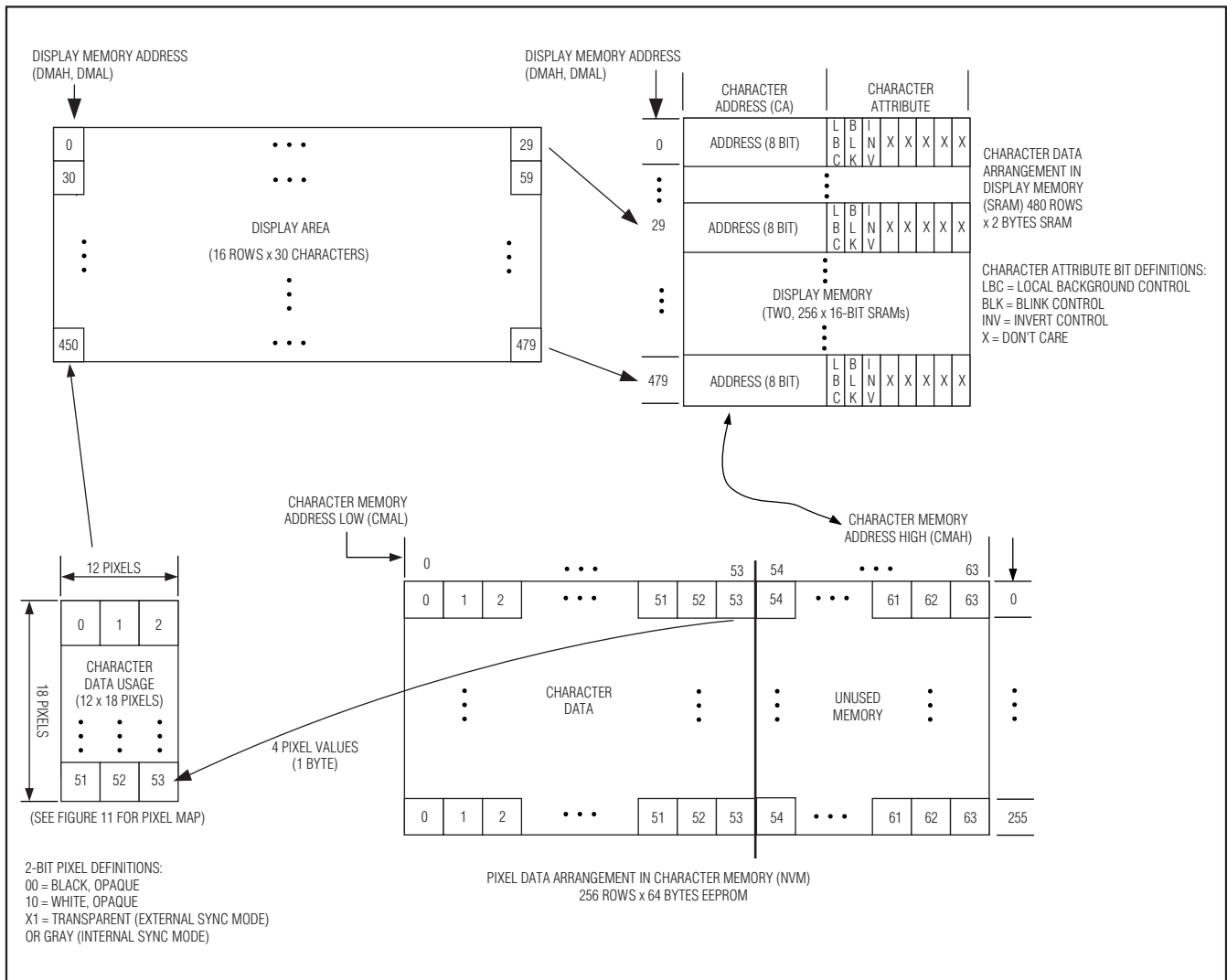

Figure 10. Definitions of Various Parameters

# MAX7456

## Single-Channel Monochrome On-Screen Display with Integrated EEPROM

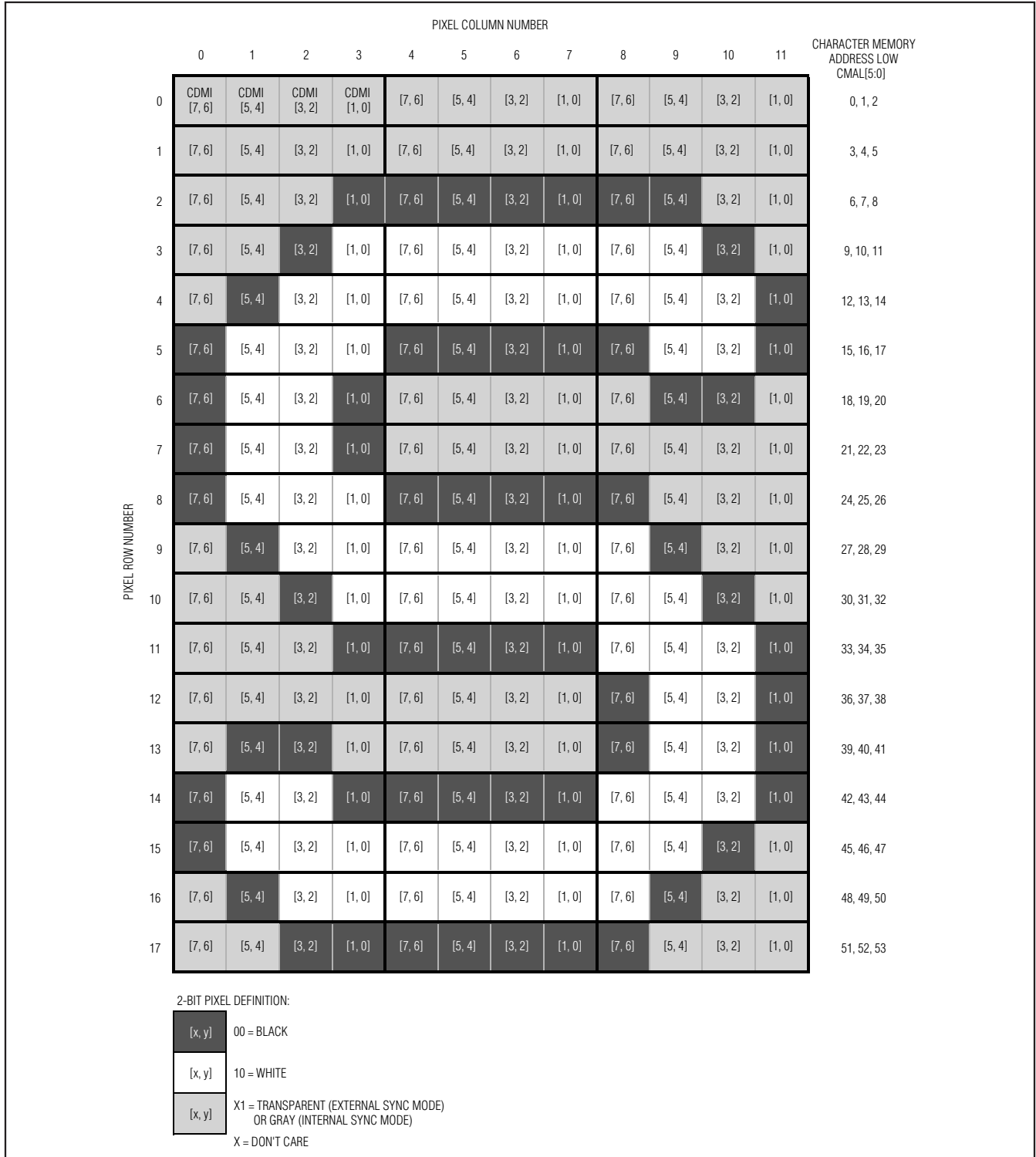

Figure 11. Character Data Usage (Pixel Map)

# MAX7456

## Single-Channel Monochrome On-Screen Display with Integrated EEPROM

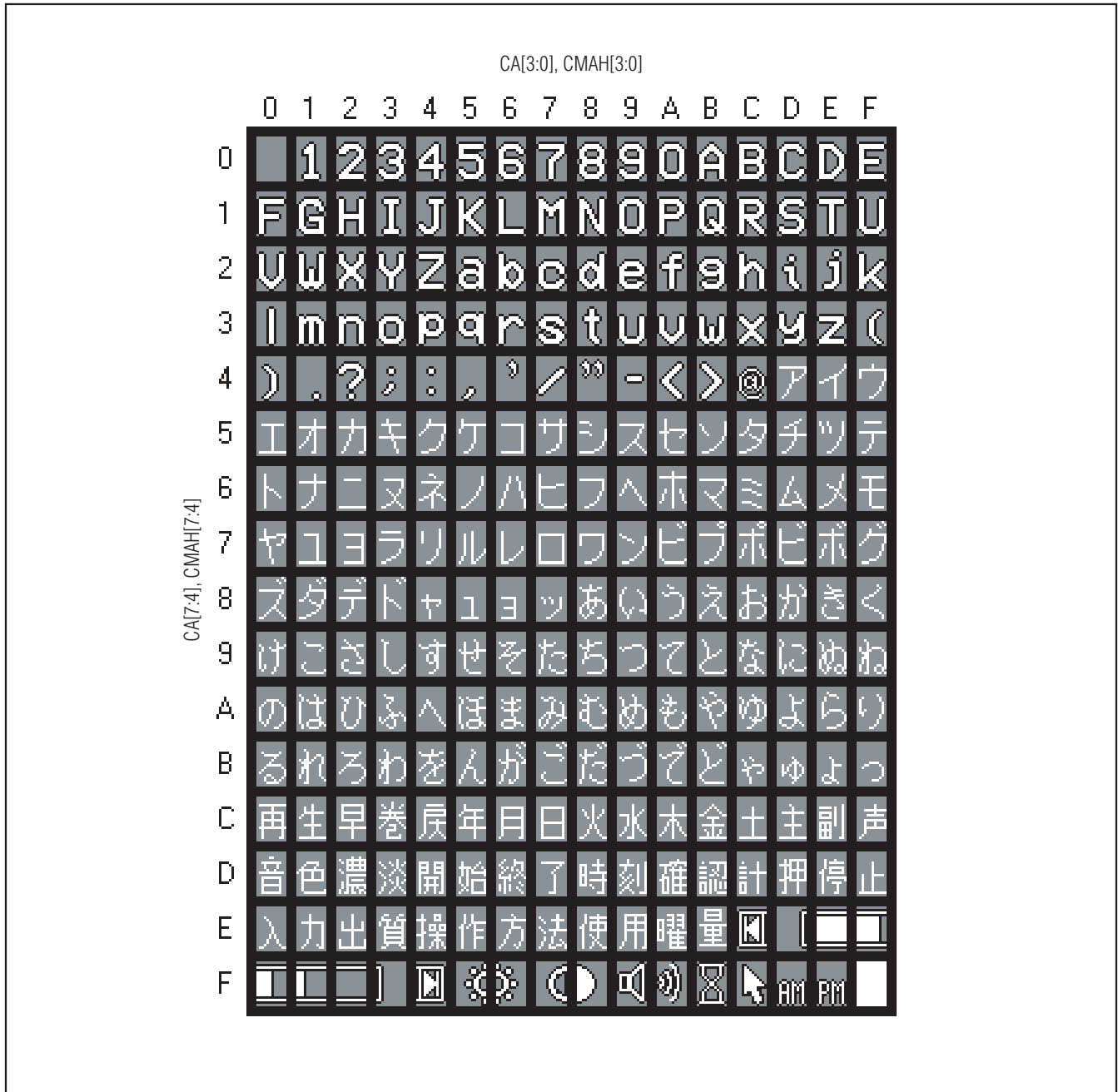

Figure 12. Character Address Map (Default Character Set)

# MAX7456

## Single-Channel Monochrome On-Screen Display with Integrated EEPROM

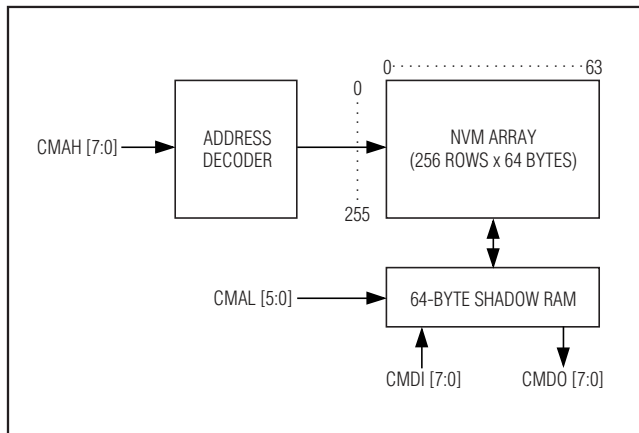

Figure 13. NVM Structure

### On-Screen Display (OSD) Generator

The OSD generator sets each pixel amplitude based on the content of the character memory and Row Brightness registers (RB0–RB15).

### OSD Insertion Mux

The OSD insertion mux selects between an OSD pixel and the input video signal. The OSD image sharpness is controlled by the OSD Rise and Fall Time bits, and the OSD Insertion Mux Switching Time bits, found in the OSD Insertion Mux (OSDM) register. This register controls the trade-off between OSD image sharpness and crosscolor/crossluma artifacts. Lower time settings produce sharper pixels, but potentially greater crosscolor/crossluma artifacts. The optimum setting depends on the requirements of the application and, therefore, can be set by the user.

### Video-Driver Output

The MAX7456 includes a video-driver output with a gain of 2. The driver has a maximum of 2.4V<sub>P-P</sub> output swing and a 6MHz large signal bandwidth ( $\leq 0.2$ dB attenuation). The driver output is capable of driving two 150 $\Omega$  standard video loads.

### Sag Correction

Sag correction is a means of reducing the electrical and physical size of the output coupling capacitor while achieving acceptable line-time distortion. Sag correction refers to the low frequency compensation of the highpass filter formed by the 150 $\Omega$  load of a back-terminated coaxial cable and the output coupling capacitor. This breakpoint must be low enough in frequency to pass the vertical sync interval ( $< 25$ Hz for PAL and  $< 30$ Hz for NTSC) to avoid field tilt. Traditionally, the breakpoint is made  $< 5$ Hz, and the coupling capacitor

must be very large, typically  $> 330\mu\text{F}$ . The MAX7456 reduces the value of this capacitor, replacing it with two smaller capacitors ( $C_{\text{OUT}}$  and  $C_{\text{SAG}}$ ), substantially reducing the size and cost of the coupling capacitors while achieving acceptable line-time distortion (Table 2). Connect SAG to VOUT if not used.

Table 2. SAG-Correction Capacitor Values

$C_{\text{OUT}}$ ( $\mu\text{F}$ )	$C_{\text{SAG}}$ ( $\mu\text{F}$ )	LINE-TIME DISTORTION (% typ)
470	—	0.2
100	—	0.4
100	22	0.3
47	47	0.3
22	22	0.4
10	10	0.6

### Serial Interface

The SPI-compatible serial interface programs the operating modes and OSD data. Read capability permits write verification and reading the Status (STAT), Display Memory Data Out (DMDO), and Character Memory Data Out (CMDO) registers.

### Read and Write Operations

The MAX7456 supports interface clocks (SCLK) up to 10MHz. Figure 15 illustrates writing data and Figure 16 illustrates reading data from the MAX7456. Bring  $\overline{\text{CS}}$  low to enable the serial interface. Data is clocked in at SDIN on the rising edge of SCLK. When  $\overline{\text{CS}}$  transitions high, data is latched into the input register. If  $\overline{\text{CS}}$  goes high in the middle of a transmission, the sequence is aborted (i.e., data does not get written into the registers). After  $\overline{\text{CS}}$  is brought low, the device waits for the first byte to be clocked into SDIN to identify the type of data transfer being executed.

The SPI commands are 16 bits long with the 8 most significant bits (MSBs) representing the register address and the 8 least significant bits (LSBs) representing the data (Figures 15 and 16). There are two exceptions to this arrangement:

- 1) Auto-increment write mode used for display memory access is a single 8-bit operation (Figure 21). When performing the auto-increment write for the display memory, the 8-bit address is internally generated, and only 8-bit data is required at the serial interface.
- 2) Reading character data from the display memory, when in 16-bit operation mode, is a 24-bit operation (8-bit address plus 16-bit data). See Figure 20.

## Single-Channel Monochrome On-Screen Display with Integrated EEPROM

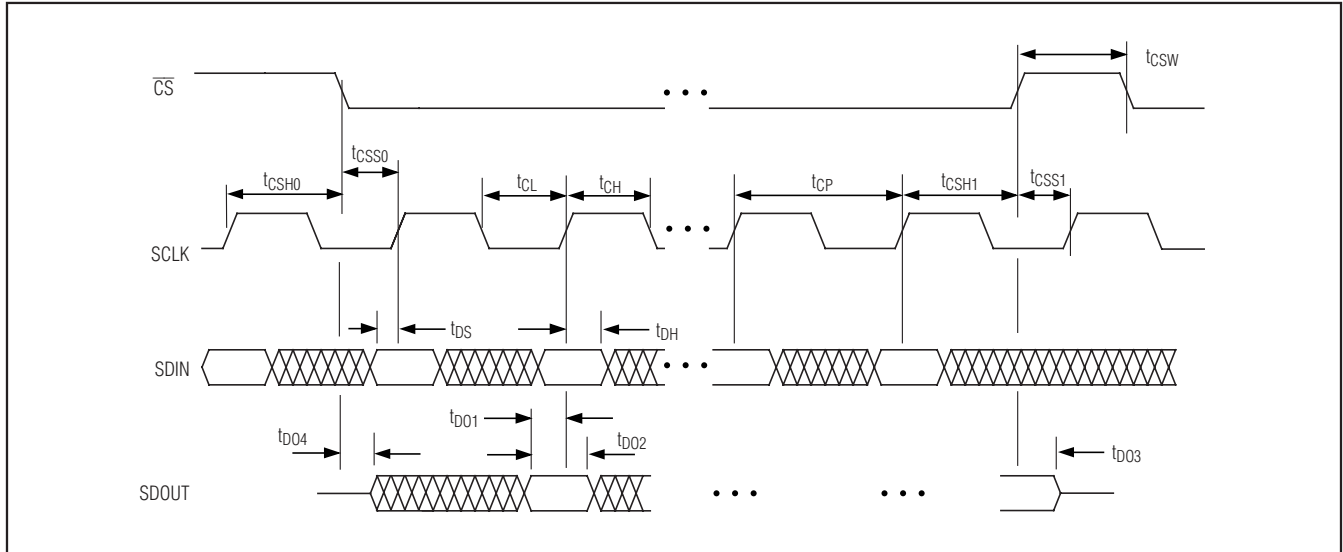

Figure 14. Detailed Serial-Interface Timing

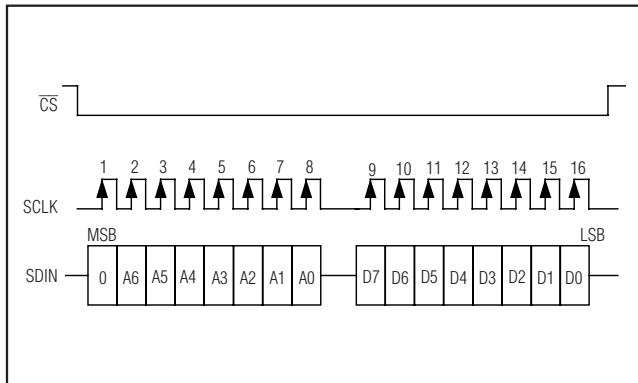

Figure 15. Write Operation

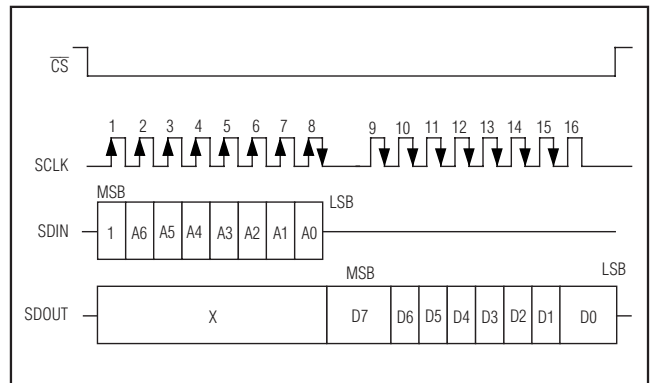

Figure 16. Read Operation

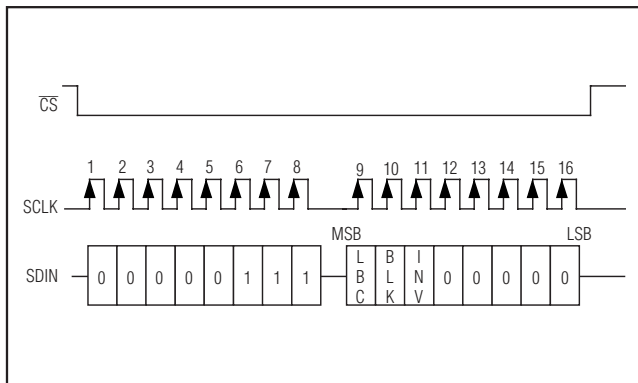

Figure 17. Writing Character Attribute Byte in 8-Bit Operation Mode

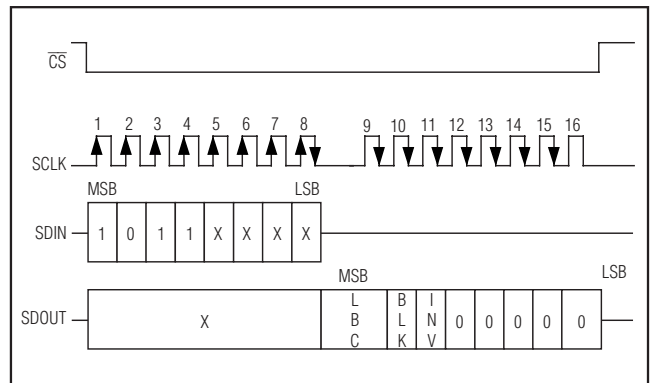

Figure 18. Reading Character Attribute Byte in 8-Bit Operation Mode

# MAX7456

## Single-Channel Monochrome On-Screen Display with Integrated EEPROM

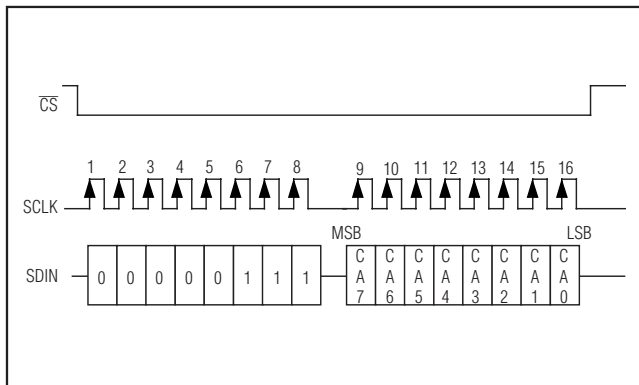

Figure 19. Writing Character Address Byte in 8-Bit and 16-Bit Operation Modes

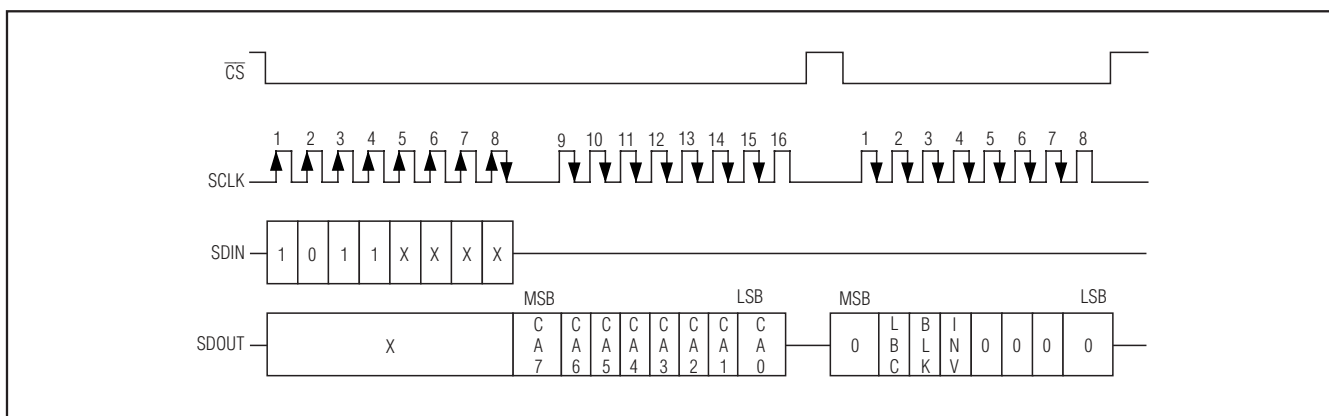

Figure 20. Reading Character Address and Character Attribute Bytes in 16-Bit Operation Mode

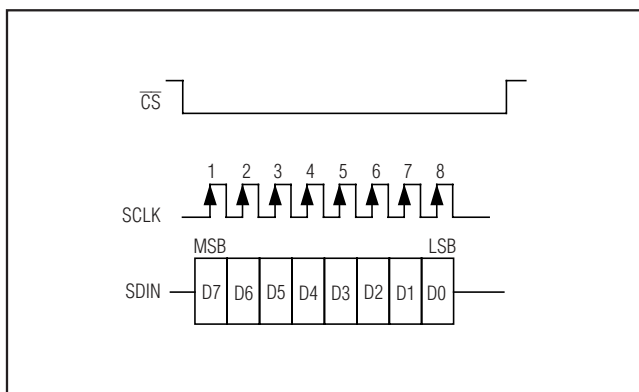

Figure 21. Write Operation in Auto-Increment Mode

### Resets

#### Power-On Reset

The MAX7456's power-on reset circuitry (POR) provides an internal reset signal that is active after the supply voltage has stabilized. The internal reset signal resets all registers to their default values and clears the display memory. The register reset process requires 100 $\mu$ s, and to avoid unexpected results, read/write activity is not allowed during this interval. The display memory is reset, and the OSD is enabled typically 50ms after the supply voltage has stabilized and a stable 27MHz clock is available. The user should avoid SPI operations during this time to avoid unexpected results. After 50ms (typical), STAT[6] can be polled to verify that the reset sequence is complete (Figure 22).

## Single-Channel Monochrome On-Screen Display with Integrated EEPROM

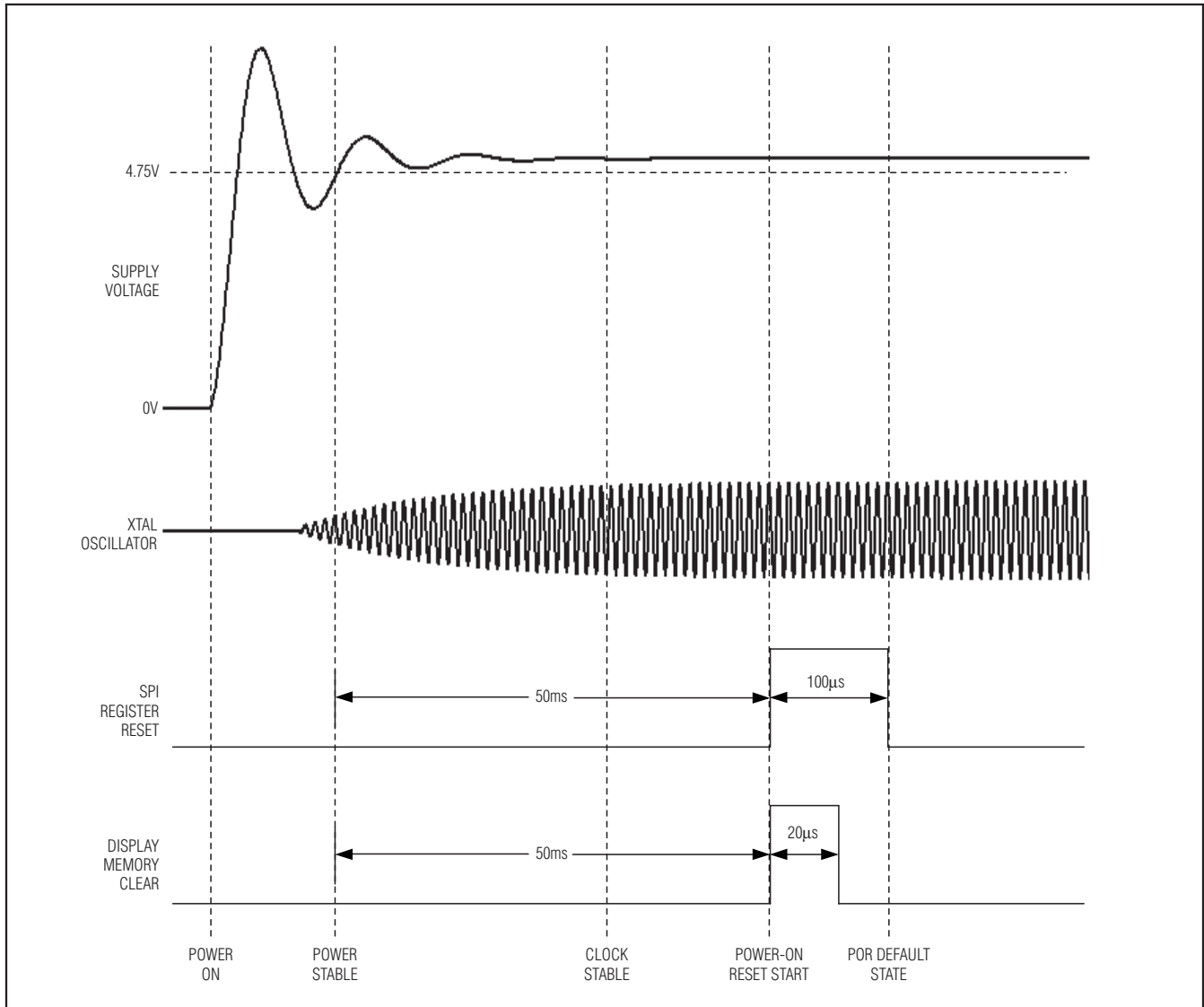

Figure 22. Power-On Reset Sequence

### Software Reset

The MAX7456 features a Software Reset bit (VM0[1]) that, when set high, clears the display memory and resets all registers to their default values except the OSD Black Level register (OSDBL). After 100µs (typical), STAT[6] can be polled to verify that the reset process is complete.

### Hardware Reset

The MAX7456 provides a hardware reset input (RESET) that functions the same as the POR. All registers are

reset to their default values and are not accessible for reading/writing when RESET is driven low. The resetting process requires a  $\geq 50\text{ms}$  wide RESET pulse, and no other activities are allowed during this interval. All SPI registers are reset to their default values 100µs after the rising edge of RESET. The display memory is reset to its default value of 00H in all locations 20µs after the rising edge of RESET. RESET takes precedence over the Software Reset bit. After RESET has been deasserted, STAT[6] can be polled to verify that the reset sequence is complete.

# MAX7456

## Single-Channel Monochrome On-Screen Display with Integrated EEPROM

### MAX7456 Register Description

Access to all MAX7456 operations, including display-memory and character-memory access, are through the SPI registers listed in Table 3. There is no direct access to the display and character memories through the SPI port. See the *Applications Information* section

for step-by-step descriptions of the SPI operations needed to access the memories.

The register format used in this data sheet is REGISTER\_NAME [BIT\_NUMBERS]. For example, bit 1 in Video Mode 0 register is written as VM0[1].

**Table 3. Register Map**

WRITE ADDRESS	READ ADDRESS	REGISTER NAME	REGISTER DESCRIPTION
00H	80H	VM0	Video Mode 0
01H	81H	VM1	Video Mode 1
02H	82H	HOS	Horizontal Offset
03H	83H	VOS	Vertical Offset
04H	84H	DMM	Display Memory Mode
05H	85H	DMAH	Display Memory Address High
06H	86H	DMAL	Display Memory Address Low
07H	87H	DMDI	Display Memory Data In
08H	88H	CMM	Character Memory Mode
09H	89H	CMAH	Character Memory Address High
0AH	8AH	CMAL	Character Memory Address Low
0BH	8BH	CMDI	Character Memory Data In
0CH	8CH	OSDM	OSD Insertion Mux
10H	90H	RB0	Row 0 Brightness
11H	91H	RB1	Row 1 Brightness
12H	92H	RB2	Row 2 Brightness
13H	93H	RB3	Row 3 Brightness
14H	94H	RB4	Row 4 Brightness
15H	95H	RB5	Row 5 Brightness
16H	96H	RB6	Row 6 Brightness
17H	97H	RB7	Row 7 Brightness
18H	98H	RB8	Row 8 Brightness
19H	99H	RB9	Row 9 Brightness
1AH	9AH	RB10	Row 10 Brightness
1BH	9BH	RB11	Row 11 Brightness
1CH	9CH	RB12	Row 12 Brightness
1DH	9DH	RB13	Row 13 Brightness
1EH	9EH	RB14	Row 14 Brightness
1FH	9FH	RB15	Row 15 Brightness
6CH	ECH	OSDBL	OSD Black Level
—	AxH	STAT	Status
—	BxH	DMDO	Display Memory Data Out
—	CxH	CMDO	Character Memory Data Out

X = Don't care.

# MAX7456

## Single-Channel Monochrome On-Screen Display with Integrated EEPROM

### Video Mode 0 Register (VM0)

Write address = 00H, read address = 80H.

Read/write access: unrestricted.

To write to this register, the following conditions must be met:

- 1) STAT[5] = 0, the character memory (NVM) is not busy.
- 2) DMM[2] = 0, the display memory (SRAM) is not in the process of being cleared.

BIT	DEFAULT	FUNCTION
7	0	Don't Care
6	0	Video Standard Select 0 = NTSC 1 = PAL
5, 4	00	Sync Select Mode (Table 1) 0x = Autosync select (external sync when LOS = 0 and internal sync when LOS = 1) 10 = External 11 = Internal
3	0	Enable Display of OSD Image 0 = Off 1 = On
2	0	Vertical Synchronization of On-Screen Data 0 = Enable on-screen display immediately 1 = Enable on-screen display at the next VSYNC
1	0	Software Reset Bit When this bit is set, all registers are set to their default values and the display memory is cleared. When a stable 27MHz clock is present, this bit is automatically cleared internally after typically 100µs. The user does not need to write a 0 afterwards. SPI operations should not be performed during this time or unpredictable results may occur. The status of the bit can be checked by reading this register after typically 100µs. This register is not accessible for writing until the display memory clear operation is finished (typically 20µs).
0	0	Video Buffer Enable 0 = Enable 1 = Disable (VOUT is high impedance)

X = Don't care.

# MAX7456

## Single-Channel Monochrome On-Screen Display with Integrated EEPROM

### Video Mode 1 Register (VM1)

Write address = 01H, read address = 81H.

Read/write access: unrestricted.

BIT	DEFAULT	FUNCTION
7	0	Background Mode (See Table 4) 0 = The Local Background Control bit (see DMM[5] and DMDI[7]) sets the state of each character background. 1 = Sets all displayed background pixels to gray. The gray level is specified by bits VM1[6:4] below. This bit overrides the local background control bit. <b>Note:</b> In internal sync mode, the background mode bit is set to 1.
6, 5, 4	100	Background Mode Brightness (% of OSD White Level) 000 = 0% 001 = 7% 010 = 14% 011 = 21% 100 = 28% 101 = 35% 110 = 42% 111 = 49%
3, 2	01	Blinking Time (BT) 00 = 2 fields (33ms in NTSC mode, 40ms in PAL mode) 01 = 4 fields (67ms in NTSC mode, 80ms in PAL mode) 10 = 6 fields (100ms in NTSC mode, 120ms in PAL mode) 11 = 8 fields (133ms in NTSC mode, 160ms in PAL mode)
1, 0	11	Blinking Duty Cycle (On : Off) 00 = BT : BT 01 = BT : (2 x BT) 10 = BT : (3 x BT) 11 = (3 x BT) : BT

### Horizontal Offset Register (HOS)

Write address = 02H, read address = 82H.

Read/write access: unrestricted (Figure 23).

BIT	DEFAULT	FUNCTION
7, 6	00	Don't Care
5-0	10 0000	Horizontal Position Offset (OSD video is not inserted into the horizontal blanking interval) 00 0000 = Farthest left (-32 pixels) ⋮ 10 0000 = No horizontal offset ⋮ 11 1111 = Farthest right (+31 pixels)

# MAX7456

## Single-Channel Monochrome On-Screen Display with Integrated EEPROM

### Vertical Offset Register (VOS)

Write address = 03H, read address = 83H.

Read/write access: unrestricted (Figure 23).

BIT	DEFAULT	FUNCTION
7, 6, 5	000	Don't Care
4-0	1 0000	Vertical Position Offset (OSD video can be vertically shifted into the vertical blanking lines) 0 0000 = Farthest up (+16 pixels) • • • 1 0000 = No vertical offset • • • 1 1111 = Farthest down (-15 pixels)

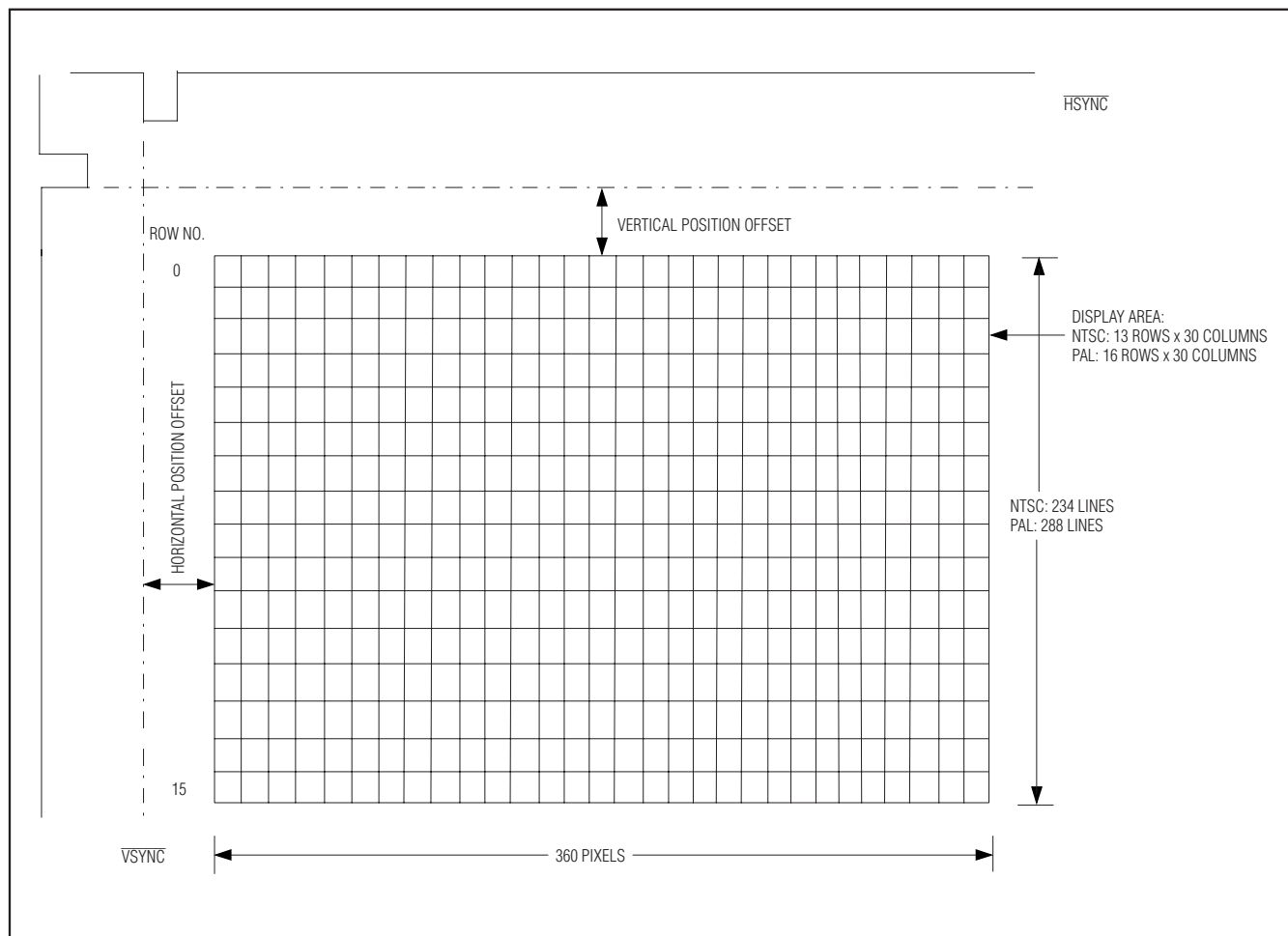

Figure 23. Character Display Area

# MAX7456

## Single-Channel Monochrome On-Screen Display with Integrated EEPROM

### Display Memory Mode Register (DMM)

Write address = 04H, read address = 84H.

Read/write access: unrestricted.

To write to this register, the following condition must be met:

DMM[2] = 0, the display memory is not in the process of being cleared.

BIT	DEFAULT	FUNCTION
7	0	Don't Care
6	0	<p>Operation Mode Selection</p> <p>0 = 16-bit operation mode The 16-bit operation mode increases the speed at which the display memory can be updated. When writing to the display memory, the attribute byte is not entered through the SPI-compatible interface. It is entered automatically by copying DMM[5:3] to a character's attribute byte when a new character is written, thus reducing the number of SPI write operations per character from two to one (Figure 19). When in this mode, all characters written to the display memory have the same attribute byte. This mode is useful because successive characters commonly have the same attribute. This mode is distinct from the 8-bit operation mode where a character attribute byte must be written each time a character address byte is written to the display memory (see Table 5). When reading data from the display memory, both the Character Address byte and Character Attribute byte are transferred with the SPI-compatible interface (Figure 18).</p> <p>1 = 8-bit operation mode The 8-bit operation mode provides maximum flexibility when writing characters to the display memory. This mode enables writing individual Character Attribute bytes for each character (see Table 5). When writing to the display memory, DMAH[1] = 0 directs the data to the Character Address byte and DMAH[1] = 1 directs the Character Attributes byte to the data. This mode is distinct from the 16-bit operation mode where the attribute bits are automatically copied from DMM[5:3] when a character is written.</p>
5	0	<p>Local Background Control Bit, LBC (see Table 4)</p> <p>Applies to characters written in 16-bit operating mode.</p> <p>0 = Sets the background pixels of the character to the video input (VIN) when in external sync mode.</p> <p>1 = Sets the background pixels of the character to the background mode brightness level defined by VM1[6:4] in external or internal sync mode.</p> <p><b>Note:</b> In internal sync mode, the local background control bit behaves as if it is set to 1.</p>
4	0	<p>Blink Bit, BLK</p> <p>Applies to characters written in 16-bit operating mode.</p> <p>0 = Blinking off</p> <p>1 = Blinking on</p> <p><b>Note:</b> Blinking rate and blinking duty cycle data in the Video Mode 1 (VM1) register are used for blinking control.</p> <p>In external sync mode: when the character is not displayed, VIN is displayed.</p> <p>In internal sync mode: when the character is not displayed, background mode brightness is displayed (see VM1[6:4]).</p>
3	0	<p>Invert Bit, INV</p> <p>Applies to characters written in 16-bit operating mode (see Figure 24).</p> <p>0 = Normal (white pixels display white, black pixels display black)</p> <p>1 = Invert (white pixels display black, black pixels display white)</p>

# MAX7456

## Single-Channel Monochrome On-Screen Display with Integrated EEPROM

### Display Memory Mode Register (DMM) (continued)

BIT	DEFAULT	FUNCTION
2	0	<p>Clear Display Memory 0 = Inactive 1 = Clear (fill all display memories with zeros)</p> <p><b>Note:</b> This bit is automatically cleared after the operation is completed (the operation requires 20<math>\mu</math>s). The user does not need to write a 0 afterwards. The status of the bit can be checked by reading this register.</p> <p>This operation is automatically performed:</p> <ul style="list-style-type: none"><li>a) On power-up</li><li>b) Immediately following the rising edge of <math>\overline{\text{RESET}}</math></li><li>c) Immediately following the rising edge of <math>\overline{\text{CS}}</math> after VM0[1] has been set to 1</li></ul>
1	0	<p>Vertical Sync Clear Valid only when clear display memory = 1, (DMM[2] = 1)</p> <p>0 = Immediately applies the clear display-memory command, DMM[2] = 1 1 = Applies the clear display-memory command, DMM[2] = 1, at the next VSYNC time</p>
0	0	<p>Auto-Increment Mode Auto-increment mode increases the speed at which the display memory can be written by automatically incrementing the character address for each successive character written. This mode reduces the number of SPI commands, and thus the time needed to write a string of adjacent characters. This mode is useful when writing strings of characters written from left-to-right, top-to-bottom, on the display (see Table 5).</p> <p>0 = Disabled 1 = Enabled</p> <p>When this bit is enabled for the first time, data in the Display Memory Address (DMAH[0] and DMAL[7:0]) registers are used as the starting location to which the data is written. When performing the auto-increment write for the display memory, the 8-bit address is internally generated, and therefore only 8-bit data is required by the SPI-compatible interface (Figure 21). The content is to be interpreted as a Character Address byte if DMAH[1] = 0 or a Character Attribute byte if DMAH[1] = 1. This mode is disabled by writing the escape character 1111 1111.</p> <p>If the Clear Display Memory bit is set, this bit is reset internally.</p>

# MAX7456

## Single-Channel Monochrome On-Screen Display with Integrated EEPROM



INVERT BIT DMM[3]	EXTERNAL SYNC MODE AND LOCAL BACKGROUND CONTROL BIT (LBC) = 0		INTERNAL SYNC MODE OR LOCAL BACKGROUND CONTROL BIT (LBC) = 1	
0				
1				

Figure 24. Character Attribute Bit Examples: Invert and Local Background Control

## Single-Channel Monochrome On-Screen Display with Integrated EEPROM

**Table 4. Character Background Control**

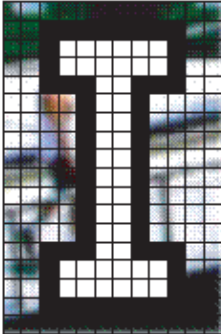
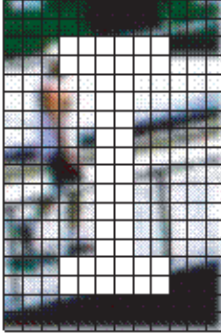
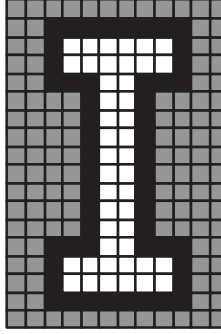
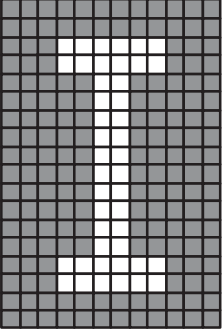
SYNC MODE	BACKGROUND MODE, VM1[7]	LOCAL BACKGROUND CONTROL BIT, LBC DMM[5], DMDI[7]	CHARACTER BACKGROUND PIXEL
External	0	0	Input Video
	0	1	Gray
	1	X	Gray
Internal	X	X	Gray

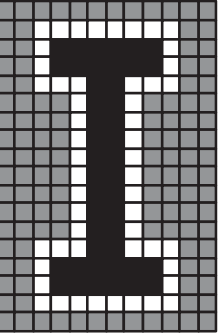
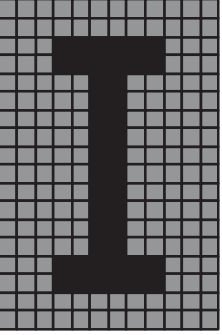
X = Don't care.

### Display Memory Address High Register (DMAH)

Write address = 05H, read address = 85H.

Read/write access: unrestricted.

To write to this register, the following condition must be met:

DMM[2] = 0, the display memory is not in the process of being cleared.

BIT	DEFAULT	FUNCTION
7-2	0000 00	Don't Care
1	0	Byte Selection Bit This bit is valid only when in the 8-bit operation mode (DMM[6] = 1). 0 = Character Address byte is written to or read (DMDI[7:0] contains the Character Address byte). 1 = Character Attribute byte is written to or read (DMDI[7:0] contains the Character Attribute byte).
0	0	Display Memory Address Bit 8 This bit is the MSB of the display-memory address. The display-memory address sets the location of a character on the display (Figure 10). The lower order 8 bits of the display-memory address is found in DMAL[7:0].

### Display Memory Address Low Register (DMAL)

Write address = 06H, read address = 86H.

Read/write access: unrestricted.

To write to this register, the following condition must be met:

DMM[2] = 0, the display memory is not in the process of being cleared.

BIT	DEFAULT	FUNCTION
7-0	0000 0000	Display Memory Address Bits 7-0 This byte is the lower 8 bits of the display-memory address. The display-memory address sets the location of a character on the display (Figure 10). The MSB of the display-memory address is DMAH[0].

# MAX7456

## Single-Channel Monochrome On-Screen Display with Integrated EEPROM

### Display Memory Data In Register (DMDI)

Write address = 07H, read address = 87H.

Read/write access: unrestricted.

To write to this register, the following condition must be met:

DMM[2] = 0, the display memory is not in the process of being cleared.

BIT	DEFAULT	FUNCTION
7-0	0000 0000	<p>Character Address or Character Attribute byte to be stored in the display memory.</p> <p>8-Bit Operation Mode (DMM[6] = 1)            If DMAH[1] = 0, the content is to be interpreted as a Character Address byte, where Bits 7-0 = Character Address bits, CA[7:0] (Figure 12).            If DMAH[1] = 1, the content is to be interpreted as a Character Attribute byte where            Bit 7 = Local Background Control bit, LBC (Figure 24 and Table 4)            Bit 6 = Blink bit, BLK            Bit 5 = Invert bit, INV (see Figure 24)            Bit 4-0 = 0            (The LBC, BLK, and INV bits are described in the Display Memory Mode register.)</p> <p>16-Bit Operation Mode (DMM[6] = 0)            The content is always interpreted as a Character Address byte where bits 7-0 = CA[7:0] (Figure 12).</p> <p>Auto-Increment Mode (DMM[0] = 1)            The character address CA[7:0] = FFH is reserved for use as an escape character that terminates the auto-increment mode. Therefore, the character located at address FFH is not available for writing to the display memory when in auto-increment mode. In all other modes, character FFH is available.</p>

## Single-Channel Monochrome On-Screen Display with Integrated EEPROM

### Character Memory Mode Register (CMM)

Write address = 08H, read address = 88H.

Read/write access: unrestricted.

To write to this register, the following conditions must be met:

- 1) STAT[5] = 0, the character memory (NVM) is not busy.
- 2) VM0[3] = 0, the OSD is disabled.

BIT	DEFAULT	FUNCTION
7-0	0000 0000	<p>Only whole characters (54 bytes) can be written to or read from the nonvolatile character memory (NVM) at one time. This is done through the (64 byte) shadow RAM (Figure 13). The shadow RAM is accessed through the SPI port one byte at a time. The shadow RAM is written to and read from NVM by the following procedures:</p> <p><b>Writing to NVM</b>            1010 XXXX = Write to NVM array from shadow RAM.            The 64 bytes from shadow RAM are written to the NVM array at the character-memory address location (CMAH, CMAL) (Figure 13). The character memory is busy for approximately 12ms during this operation. During this time, STAT[5] is automatically set to 1. The Character Memory Mode register is cleared and STAT[5] is reset to 0 after the write operation has been completed. The user does not need to write zeros afterwards.</p> <p><b>Reading from NVM</b>            0101 XXXX = Read from NVM array into shadow RAM.            The 64 bytes corresponding to the character-memory address (CMAH, CMAL) are read from the NVM array into the shadow RAM (Figure 13). The character memory is busy for approximately 0.5μs during this operation. The CMM register is cleared after the operation is completed. The user does not need to write zeros afterwards. During this time, STAT[5] is automatically set to 1. STAT[5] is reset to 0 when the read operation has been complete.</p> <p>If the display has been enabled (VM0[3] = 1) or the character memory is busy (STAT[5] = 1), NVM read/write operation commands are ignored and the corresponding registers are not updated. However, all the registers can be read at any time.</p> <p>For all the character-memory operations, the character address is formed with Character Memory Address High (CMAH[7:0]) and Character Memory Address Low (CMAL[7:0]) register bits (Figures 11, 12, and 13).</p>

X = Don't care.

# MAX7456

## Single-Channel Monochrome On-Screen Display with Integrated EEPROM

### Character Memory Address High Register (CMAH)

Write address = 09H, read address = 89H.

Read/write access: unrestricted.

To write to this register, the following conditions must be met:

- 1) STAT[5] = 0, the character memory (NVM) is not busy.
- 2) VM0[3] = 0, the OSD is disabled.

BIT	DEFAULT	FUNCTION
7-0	0000 0000	Character Memory Address Bits These 8 bits point to a character in the character memory (256 characters total in NVM) (Figures 10 and 12).

### Character Memory Address Low Register (CMAL)

Write address = 0AH, read address = 8AH.

Read/write access: unrestricted.

To write to this register, the following conditions must be met:

- 1) STAT[5] = 0, the character memory (NVM) is not busy.
- 2) VM0[3] = 0, the OSD is disabled.

BIT	DEFAULT	FUNCTION
7, 6	00	Don't Care
5-0	00 0000	Character Memory Address Bits These 6 bits point to one of the 64 bytes (only 54 used) that represent a 4-pixel group in the character (Figures 10 and 11).

### Character Memory Data In Register (CMDI)

Write address = 0BH, read address = 8BH.

Read/write access: unrestricted.

To write to this register, the following conditions must be met:

- 1) STAT[5] = 0, the character memory (NVM) is not busy.
- 2) VM0[3] = 0, the OSD is disabled.

BIT	DEFAULT	FUNCTION
7, 6	NA	Leftmost pixel. 00 = Black, 10 = White, 01 or 11 = Transparent (see Figure 11)
5, 4	NA	Left center pixel. 00 = Black, 10 = White, 01 or 11 = Transparent (see Figure 11)
3, 2	NA	Right center pixel. 00 = Black, 10 = White, 01 or 11 = Transparent (see Figure 11)
1, 0	NA	Rightmost pixel. 00 = Black, 10 = White, 01 or 11 = Transparent (see Figure 11)

NA = Not applicable.

# MAX7456

## Single-Channel Monochrome On-Screen Display with Integrated EEPROM

### OSD Insertion Mux Register (OSDM)

Write address = 0CH, read address = 8CH.

Read/write access: unrestricted.

BIT	DEFAULT	FUNCTION
7, 6	00	Don't Care
5, 4, 3	011	OSD Rise and Fall Time—typical transition times between adjacent OSD pixels 000: 20ns (maximum sharpness/maximum crosscolor artifacts ) 001: 30ns 010: 35ns 011: 60ns 100: 80ns 101: 110ns (minimum sharpness/minimum crosscolor artifacts)
2, 1, 0	011	OSD Insertion Mux Switching Time—typical transition times between input video and OSD pixels 000: 30ns (maximum sharpness/maximum crosscolor artifacts ) 001: 35ns 010: 50ns 011: 75ns 100: 100ns 101: 120ns (minimum sharpness/minimum crosscolor artifacts)

### Row N Brightness Register (RB0-RB15)

Address = 10H + row number; write address = 10H through 1FH, read address = 90H through 9FH, read/write access: unrestricted.

Top row number is 0. Bottom row number is 13 in NTSC mode and 15 in PAL mode (see Figure 23).

BIT	DEFAULT	FUNCTION
7-4	0000	Don't Care
3, 2	00	Character Black Level —All the characters in row N use these brightness levels for the black pixel, in % of OSD white level. 00 = 0% 01 = 10% 10 = 20% 11 = 30%
1, 0	01	Character White Level —All the characters in row N use these brightness levels for the white pixel, in % of OSD white level. 00 = 120% 01 = 100% 10 = 90% 11 = 80%

# MAX7456

## Single-Channel Monochrome On-Screen Display with Integrated EEPROM

### OSD Black Level Register (OSDBL)

Write address = 6CH, read address = ECH.

Read/write access: This register contains 4 factory-preset bits [3:0] that must not be changed. Therefore,

when changing bit 4, first read this register, modify bit 4, and then write back the updated byte.

BIT	DEFAULT	FUNCTION
7–5	000	Don't Care
4	1	OSD Image Black Level Control This bit enables the alignment of the OSD image black level with the input image black level at VOUT. Always enable this bit following power-on reset to ensure the correct OSD image brightness. 0 = Enable automatic OSD black level control 1 = Disable automatic OSD black level control
0–3	xxxx	These bits are factory preset. To ensure proper operation of the MAX7456, do not change the values of these bits.

xxxx = Factory preset—can be any one of the 16 possible values. This value is permanently stored in the MAX7456 and will always be restored to the factory preset value following power-on reset or hardware reset.

### Status Register (STAT)

Read address = AxH.

Read/write access: read only.

BIT	DEFAULT	FUNCTION
7	NA	Don't Care
6	NA	Reset Mode 0 = Clear when power-up reset mode is complete. Occurs 50ms (typ) following stable V <sub>DD</sub> (Figure 22) 1 = Set when in power-up reset mode
5	NA	Character Memory Status 0 = Available to be written to or read from 1 = Unavailable to be written to or read from
4	NA	$\overline{\text{VSYNC}}$ Output Level 0 = Active during vertical sync time 1 = Inactive otherwise
3	NA	$\overline{\text{HSYNC}}$ Output Level 0 = Active during horizontal sync time 1 = Inactive otherwise
2	NA	Loss-of-Sync (LOS) 0 = Sync Active. Asserted after 32 consecutive input video lines. 1 = No Sync. Asserted after 32 consecutive missing input video lines.
1	NA	0 = NTSC signal is not detected at VIN 1 = NTSC signal is detected at VIN
0	NA	0 = PAL signal is not detected at VIN 1 = PAL signal is detected at VIN

NA = Not applicable.

X = Don't care.

## Single-Channel Monochrome On-Screen Display with Integrated EEPROM

### Display Memory Data Out Register (DMDO)

Read address = BxH.

Read/write access: read only.

To write to this register the following condition must be met:

DMM[2] = 0, the display memory is not in the process of being cleared.

BIT	DEFAULT	FUNCTION
7-0	NA	<p>Character Address or Character Attribute byte to be read from the display memory.</p> <p>8-Bit Operation Mode (DMM[6] = 1):            If DMAH[1] = 0, the content is to be interpreted as a Character Address byte, where            Bits 7-0 = Character Address bits, CA[7:0] (Figure 12)            If DMAH[1] = 1, the content is to be interpreted as a Character Attribute byte where            Bit 7 = Local Background Control bit, LBC (see Figure 24 and Table 4)            Bit 6 = Blink bit, BLK            Bit 5 = Invert bit, INV (see Figure 24)            Bit 4-0 = 0            The LBC, BLK, and INV bits are described in the Display Memory Mode register.</p> <p>16-Bit Operation Mode (DMM[6] = 0):            The content is to be interpreted as a Character Address byte, where            Bits 7-0 = CA[7:0] (see Figure 12)            followed by a Character Attribute byte, where            Bit 7 = 0            Bit 6 = Local Background Control bit, LBC (see Figure 24 and Table 4)            Bit 5 = Blink bit, BLK            Bit 4 = Invert bit, INV (see Figure 24)            Bit 3-0 = 0            The LBC, BLK, and INV bits are described in the Display Memory Mode register.</p>

NA = Not applicable.

X = Don't care.

### Character Memory Data Out Register (CMDO)

Read address = CxH.

Read/write access: read only.

To write to this register, the following conditions must be met:

1) STAT[5] = 0, the character memory (NVM) is not busy.

2) VM0[3] = 0, the OSD is disabled.

BIT	DEFAULT	FUNCTION
7, 6	NA	Leftmost pixel. 00 = Black, 10 = White, 01 or 11 = Transparent (see Figure 11)
5, 4	NA	Left center pixel. 00 = Black, 10 = White, 01 or 11 = Transparent (see Figure 11)
3, 2	NA	Right center pixel. 00 = Black, 10 = White, 01 or 11 = Transparent (see Figure 11)
1, 0	NA	Rightmost pixel. 00 = Black, 10 = White, 01 or 11 = Transparent (see Figure 11)

NA = Not applicable.

X = Don't care.

# MAX7456

## Single-Channel Monochrome On-Screen Display with Integrated EEPROM

### Applications Information

#### Character-Memory Operation

Only whole characters (54 bytes of pixel data) can be written to or read from the NVM character memory at one time. This is done through the (64 byte) shadow RAM (see Figure 13). The shadow RAM is accessed by the SPI port one byte at a time. The shadow RAM is written to and read from the NVM by a single SPI command.

#### Steps for Writing Character Bytes into the NVM Character Memory

##### Writing a new character:

- 1) Write VM0[3] = 0 to disable the OSD image display.
- 2) Write CMAH[7:0] = xxH to select the character (0–255) to be written (Figures 10 and 13).
- 3) Write CMAL[7:0] = xxH to select the 4-pixel byte (0–63) in the character to be written (Figures 10 and 13).
- 4) Write CMDI[7:0] = xxH to set the pixel values of the selected part of the character (Figures 11 and 13).
- 5) Repeat steps 3 and 4 until all 54 bytes of the character data are loaded into the shadow RAM.
- 6) Write CMM[7:0] = 1010xxxx to write to the NVM array from the shadow RAM (Figure 13). The character memory is busy for approximately 12ms during this operation. STAT[5] can be read to verify that the NVM writing process is complete.
- 7) Write VM0[3] = 1 to enable the OSD image display.

##### Modifying an existing character:

- 1) Write VM0[3] = 0 to disable the OSD image display.
- 2) Write CMAH[7:0] = xxH to select the character (0–255) to be modified (Figures 10 and 13).
- 3) Write CMM[7:0] = 0101xxxx to read character data from the NVM to the shadow RAM (Figure 13).
- 4) Write CMAL[7:0] = xxH to select the 4-pixel byte (0–63) in the character to be modified (Figures 10 and 13).
- 5) Read CMDO[7:0] = xxH to read the byte of 4-pixel data to be modified (Figures 11 and 13).
- 6) Modify the byte of 4-pixel data as desired.
- 7) Write CMDI[7:0] = xxH to write the modified byte of 4-pixel data back to the shadow RAM (Figures 11 and 13).
- 8) Repeat steps 4 through 7 as needed until all pixels have been loaded into the shadow RAM.
- 9) Write CMM[7:0] = 1010xxxx to write the shadow RAM data to the NVM (Figure 13). The character

memory is busy for typically 12ms during this operation. STAT[5] can be read to verify that the NVM writing process is complete.

- 10) Write VM0[3] = 1 to enable the OSD image display.

#### Steps for Reading Character Bytes from Character Memory

- 1) Write VM0[3] = 0 to disable the OSD image.
- 2) Write CMAH[7:0] = xxH to select the character (0–255) to be read (Figures 10 and 13).
- 3) Write CMM[7:0] = 0101xxxx to read the character data from the NVM to the shadow RAM (Figure 13).
- 4) Write CMAL[7:0] = xxH to select the 4-pixel byte (0–63) in the character to be read (Figures 10 and 13).
- 5) Read CMDO[7:0] = xxH to read the selected 4-pixel byte of data (Figures 11 and 13).
- 6) Repeat steps 4 and 5 to read other bytes of 4-pixel data.
- 7) Write VM0[3] = 1 to enable the OSD image display.

#### Display-Memory Operation

The following two steps enable viewing of the OSD image. These steps are not required to read from or write to the display memory:

- 1) Write VM0[3] = 1 to enable the display of the OSD image.
- 2) Write OSDBL[4] = 0 to enable automatic OSD black level control. This ensures the correct OSD image brightness. This register contains 4 factory-preset bits [3:0] that must not be changed. Therefore, when changing bit 4, first read OSDBL[7:0], modify bit 4, and then write back the updated byte.

#### Steps for Clearing Display Memory

Write DMM[2] = 1 to start the clear display-memory operation. This operation typically takes 20μs. The Display Memory Mode register cannot be written to again until the clear operation is complete. DMM[2] is automatically reset to zero upon completion.

#### Steps for Writing to Display Memory in 8-Bit Mode

The 8-bit operation mode provides maximum flexibility when writing characters to the display memory. This mode enables writing individual Character Attribute bytes for each character (see Table 5). This mode is distinct from the 16-bit operation mode where the Character Attribute byte is automatically copied from DMM[5:3] when a character is written (Figure 19).

Write DMM[6] = 1 to select the 8-bit operation mode.

## Single-Channel Monochrome On-Screen Display with Integrated EEPROM

### Writing the Character Address Byte to the Display Memory:

- 1) Write DMAH[1] = 0 to write a Character Address byte.
- 2) Write DMAH[0] = x to select the MSB and DMAL[7:0] = xxH to select the lower order bits of the address where the character data is to be written. This address determines the location of the character on the display (see Figure 10).
- 3) Write the Character Address byte (CA[7:0]) to be written to the display memory to DMDI[7:0] (see Figures 10, 12, and 19).

### Writing the Character Attribute Byte to the Display Memory:

- 1) Write DMAH[1] = 1 to write a Character Attribute byte.
- 2) Write DMAH[0] = x to select the MSB and DMAL[7:0] = xxH to select the lower order bits of the address where the character data is to be written. This address determines the location of the character on the display (Figure 10).
- 3) Write the Character Attribute byte to be written to the display memory to DMDI[7:0] (see Figures 10 and 19).

### Steps for Writing to Display Memory in 16-Bit Mode

The 16-bit operation mode increases the speed at which the display memory can be updated. This is done by automatically copying DMM[5:3] to a Character's Attribute byte when a new character is written, thus reducing the number of SPI write operations per character from two to one (Figure 19). When in this mode, all characters written to the display memory have the same attribute byte. This mode is useful because successive characters commonly have the same attribute. This mode is distinct from the 8-bit operation mode where a Character Attribute byte must be written each time a Character Address byte is written to the display memory (see Table 5).

- 1) Write DMM[6] = 0 to select the 16-bit operation mode.
- 2) Write DMM[5:3] = xxx to set the Local Background Control (LBC), Blink (BLK), and Invert (INV) attribute bits that will be applied to all characters written to the display memory while in the 16-bit operation mode.
- 3) Write DMAH[0] = x to select the MSB and DMAL[7:0] = xxH to select the lower order bits of the address where the character data is to be written.

This address determines the location of the character on the display (see Figure 10).

- 4) Write the Character Address byte (CA[7:0]) to be written to the display memory into DMDI[7:0]. It will be stored along with a Character Attribute byte derived from DMM[5:3] (Figures 12 and 19).

### Steps for Writing to Display Memory in Auto-Increment Mode

Auto-increment mode increases the speed at which the display memory can be written by automatically incrementing the character address for each successive character written. This mode is useful when writing strings of characters written from left-to-right and top-to-bottom on the display. This mode reduces the number of SPI commands (see Table 5).

### When in 8-Bit Operating Mode:

- 1) Write DMAH[1] = 0 to select if the Character Address byte will be written or DMAH[1] = 1 to select if the Character Attribute byte will be written.
- 2) Write DMAH[0] = X to select the MSB and DMAL[7:0] = XX to select the lower order address bits of the starting address for auto-increment operation. This address determines the location of the first character on the display (see Figures 10 and 21).
- 3) Write DMM[0] = 1 to set the auto-increment mode.
- 4) Write DMM[6] = 1 to set the 8-bit operating mode.
- 5) Write CA data in the intended character order to display text on the screen. This is the single byte operation. The DMDI[7:0] address is automatically set by auto-increment mode. The display memory address is automatically incremented following the write operation until the final display memory address is reached.
- 6) Write CA = FFh to terminate the auto-increment mode.

**Note:** The character stored at CA[7:0] = FFh is not available for use in auto-increment mode. Read operation is not possible before auto-increment mode is terminated.

### When in 16-Bit Operating Mode:

- 1) Write DMAH[0] = X to select the MSB and DMAL[7:0] = XX to select the lower order address bits of the starting address for auto-increment operation. This address determines the location of the first character on the display (see Figures 10 and 21).
- 2) Write DMM[0] = 1 to set the auto-increment mode.
- 3) Write DMM[6] = 0 to set the 16-bit operating mode.

# MAX7456

## Single-Channel Monochrome On-Screen Display with Integrated EEPROM

- 4) Write DMM[5:3] = XXX to set the Local Background Control (LBC), Blink (BLK) and Invert (INV) attribute bits that will be applied to all characters.
- 5) Write CA data in the intended character order to display text on the screen. It will be stored along with a Character Attribute byte derived from DMM[5:3]. See Figure 19. This is the single byte operation. The DMDI[7:0] address is automatically set by auto-increment mode. The display memory address is automatically incremented following the write operation until the final display memory address is reached.
- 6) Write CA = FFh to terminate the auto-increment mode.

**Note:** The character stored at CA[7:0] = FFh is not available for use in auto-increment mode. Read operation is not possible before auto-increment mode is terminated.

### Steps for Reading from Display Memory in 8-Bit Mode

- 1) Write DMM[6] = 1 to select the 8-bit operation mode.
- 2) Write DMAH[1] = 0 to read the Character Address byte or DMAH[1] = 1 to read the Character Attribute byte.
- 3) Write to DMAH[0] to select the MSB of the address where data must be read from (Figure 10).
- 4) Write to DMAL[7:0] to select all the lower order bits, except for the MSB, of the address where data must be read from (Figure 10).
- 5) Read DMDO[7:0] to read the data from the selected location in the display memory (Figure 10).

### Steps for Reading from Display Memory in 16-Bit Mode

- 1) Write DMM[6] = 0 to select the 16-bit operation mode.

- 2) Write DMAH[0] = x to select the MSB and DMAL[7:0] = xxH to select the lower order bits of the address where the character data is to be read. This address determines the location of the character on the display (see Figure 10).
- 3) Read DMDO[15:0] to read the Character Address byte and the Character Attribute byte from the selected location in the display memory. The first data byte is the Character Address (CA[7:0]), and the second byte contains the Character Attribute bits (Figure 20). Note that the bit positions of the Character Attribute byte when read, differ from when they are written. See the *Display Memory Data Out Register (DMDO)* section and Figure 20 for a description of the bit locations of the attribute bits when reading.

**Note:** If an internal display-memory read request occurs simultaneously with an SPI display-memory operation, the internal read request is ignored, and the display of that character, during that field time, may appear to momentarily break up. See the *Synchronous OSD Updates* section.

### Synchronous OSD Updates

The display of a character may momentarily appear to break up if an internal display-memory read request occurs simultaneously with an SPI display-memory operation. Momentary breakup of the OSD image can be prevented by writing to the display memory during the vertical blanking interval. This can be achieved by using  $\overline{VSYNC}$  as an interrupt to the host processor to initiate writing to the display memory. Alternatively, the OSD image can be synchronously disabled before writing to the display memory and synchronously re-enabled afterwards (see VM0[3:2]).

**Table 5. Display-Memory Access Modes and SPI Operations**

OPERATING MODE	AUTO-INCREMENT MODE DISABLED DMM[0] = 0	No. OF READ OPERATIONS	No. OF WRITE OPERATIONS	AUTO-INCREMENT MODE ENABLED DMM[0] = 1	No. OF WRITE OPERATIONS
16-Bit Mode DMM[6] = 0	One-time setup	2	1	One-time setup	6
	Per character	3	3	Per character	1
8-Bit Mode DMM[6] = 1	One-time setup	1	1	One-time setup	6
	Per character	6	6	Per character	1



# MAX7456

## Single-Channel Monochrome On-Screen Display with Integrated EEPROM

### Multiple OSDs with Common Clock Application

The MAX7456 provides a TTL clock output (CLKOUT) capable of driving one CLKIN pin of another MAX7456. Two or more MAX7456 parts can be driven using an external clock driver. This arrangement reduces the system cost by having only one crystal on one MAX7456 that supplies the clock signal to multiple MAX7456 parts (Figure 25).

### Selecting a Clock Crystal

Choose a 27MHz parallel resonant, fundamental mode crystal. No external load capacitors are needed. All capacitors required for the Pierce oscillator are included on-chip.

### Power Supply and Bypassing

The MAX7456 operates from three independent supply lines. Each supply must be within a +4.75V to +5.25V voltage range. Separate the digital power supply from the analog and video-driver supply lines to prevent high-frequency digital noise that may couple onto the video output. All three supplies should be at the same DC voltage. Bypass each supply with a 0.1 $\mu$ F capacitor to ground very close to the IC pins. There are no power-supply sequencing requirements for the device.

### Layout Concerns

For best performance, make the VIN and VOUT traces as short as possible. Place all AC-coupling capacitors and 75 $\Omega$  termination resistors close to the device with the resistors terminated to the solid analog ground plane. Since the MAX7456 TSSOP package has an exposed pad (EP) underneath, do not run traces under the package to avoid possible short circuits. Refer to the MAX7456 EV kit for an example of PCB layout.

To aid heat dissipation, the EP should be connected to a similarly sized pad on the component side of the PCB. This pad should be connected through to the solder-side copper by several plated holes to conduct heat away from the device. The solder-side copper pad area should be larger than the EP area. It is recommended that the EP be connected to ground, but it is not required. Do not use EP as the only ground connection for the device.

### Pin Configuration

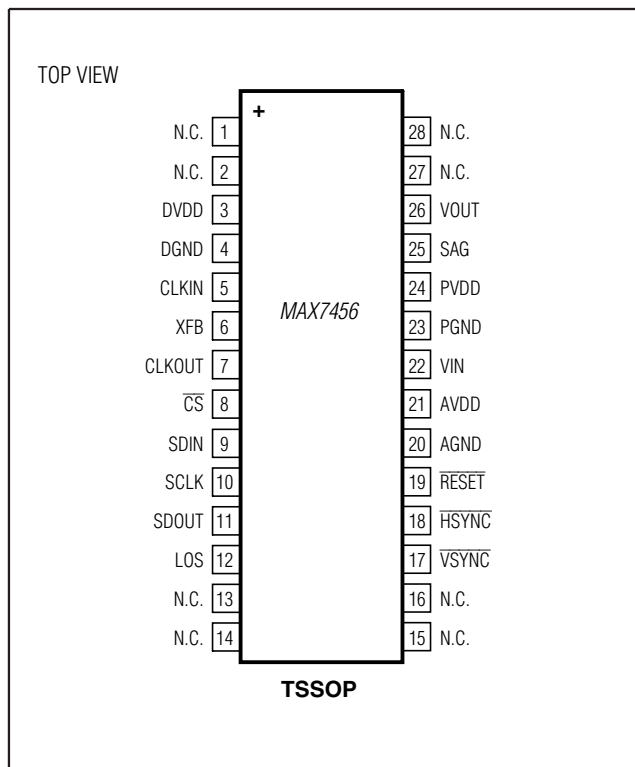

### Chip Information

PROCESS: BiCMOS

# MAX7456

## Single-Channel Monochrome On-Screen Display with Integrated EEPROM

### Package Information

For the latest package outline information and land patterns, go to [www.maxim-ic.com/packages](http://www.maxim-ic.com/packages).

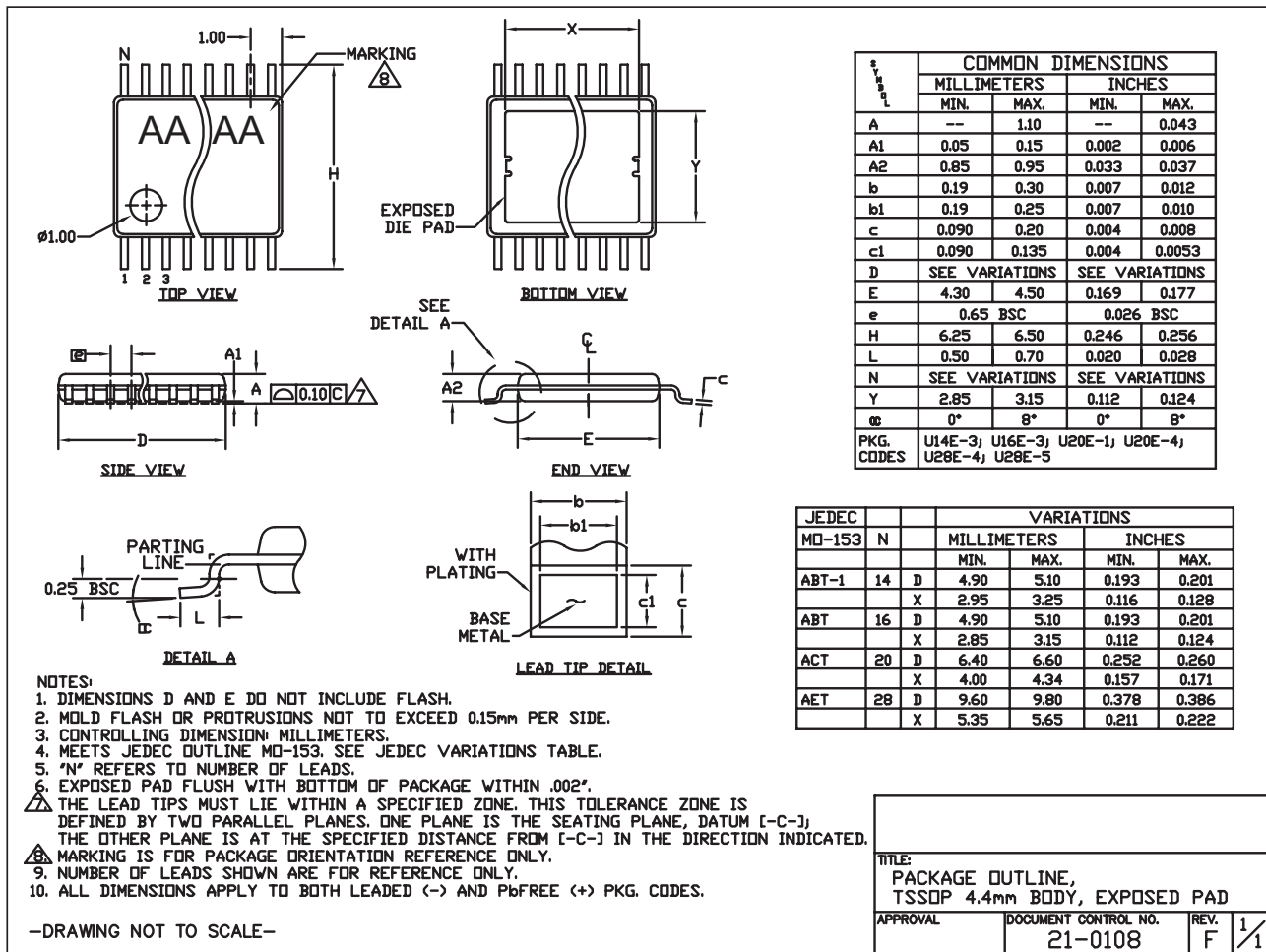

TSSOP 4.4mm BODY.EPS

PACKAGE TYPE	PACKAGE CODE	DOCUMENT NO.
20 TSSOP-EP	U28E-5	<a href="#">21-0108</a>

# MAX7456

## Single-Channel Monochrome On-Screen Display with Integrated EEPROM

### Revision History

REVISION NUMBER	REVISION DATE	DESCRIPTION	PAGES CHANGED
0	8/07	Initial release	—
1	8/08	Updated procedures in <i>Steps for Writing to Display Memory in Auto-Increment Mode</i> section	39, 40



Maxim cannot assume responsibility for use of any circuitry other than circuitry entirely embodied in a Maxim product. No circuit patent licenses are implied. Maxim reserves the right to change the circuitry and specifications without notice at any time. The parametric values (min and max limits) shown in the Electrical Characteristics table are guaranteed. Other parametric values quoted in this data sheet are provided for guidance.

## Looking for pricing, stock, or lifecycle information?

Click below to explore more details on WIN SOURCE:

- ⊖ [View MAX7456EUI+T on WIN SOURCE](#)
- ⊖ [Maxim Integrated Information](#)

## Optimize Your Supply Chain with WIN SOURCE Solutions

- ✓ Global Sourcing Solution
- ✓ Obsolete Management
- ✓ Cost Control Management
- ✓ Shortage Management
- ✓ Alternative Solution
- ✓ Excess Inventory Management