



**THE DATASHEET OF
MAX7449EUD-T**



3-Channel Video Reconstruction Filter for RGB Component Video

General Description

The MAX7449, 3-channel, buffered video reconstruction filter is ideal for anti-aliasing and digital-to-analog converter (DAC)-smoothing video applications or wherever analog video is reconstructed from a digital data stream (such as cable/satellite/terrestrial set-top boxes, DVD players, hard-disk recorders (HDRs), and personal video recorders (PVRs)). This device operates from a single +5V supply and has a flat passband out to 5MHz with a stopband attenuation of 43dB at 27MHz. This makes it ideal for use with NTSC, PAL, and standard-definition digital TV (SDTV) video systems. Each output is capable of driving two standard 150Ω video loads.

The MAX7449 processes component RGB video signals. The output video buffers have a fixed gain of +6dB. The output video drivers can be disabled with an external pin.

The MAX7449 is available in a 14-pin TSSOP package with an exposed pad, and is specified over the -40°C to +85°C extended temperature range.

Applications

Set-Top Boxes/HDRs Game Consoles
Desktop Video Editors DVD Players
Digital VCRs

Features

- ◆ 3-Channel Filter and Buffer for RGB Video Signals
- ◆ External Sync Signal Input
- ◆ Filter Response Ideal for NTSC, PAL, and Interlaced SDTV Video Signals
- ◆ 43dB (typ) Stopband Attenuation at 27MHz
- ◆ ±0.75dB (max) Passband Ripple at 5MHz
- ◆ Blanking Level Voltage on Output <1V
- ◆ Each Channel Drives Two 150Ω Video Loads
- ◆ +5V Single-Supply Voltage
- ◆ Small 14-Pin TSSOP Package

Ordering Information

PART	TEMP RANGE	PIN-PACKAGE	PACKAGE CODE
MAX7449EUD	-40°C to +85°C	14 TSSOP-EP*	U14E-3

*EP = Exposed pad.

Pin Configuration appears at end of data sheet.

Functional Diagram

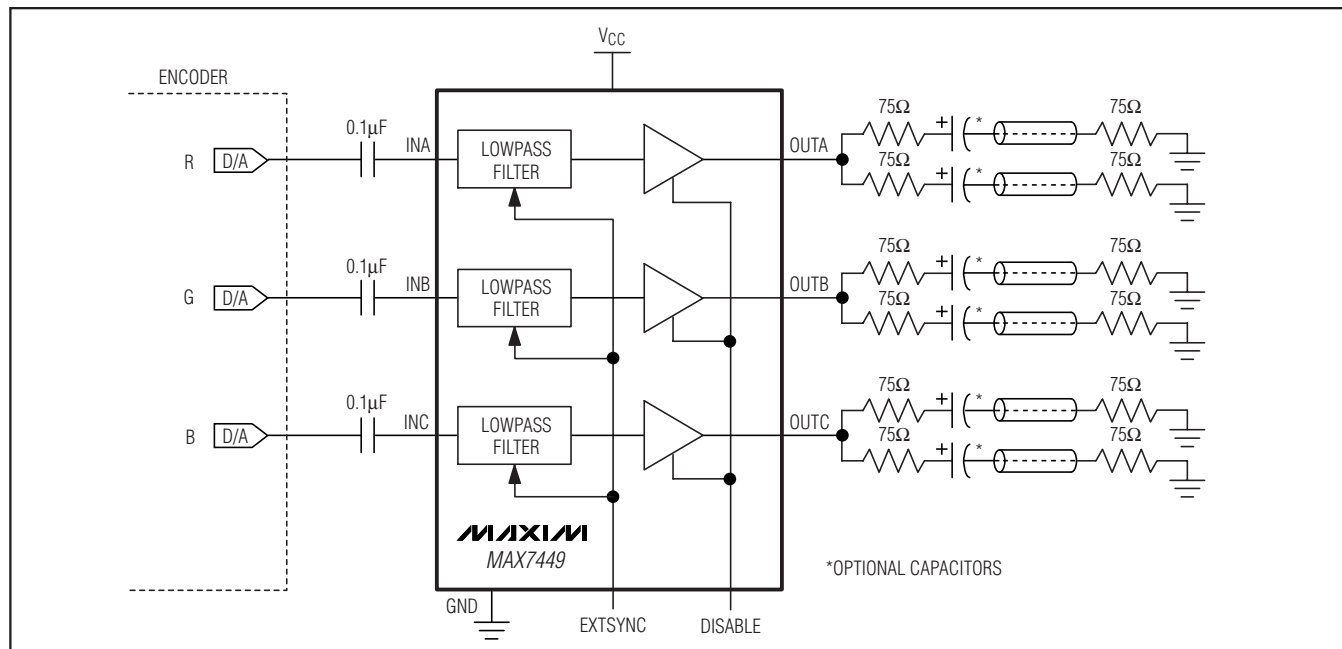

3-Channel Video Reconstruction Filter for RGB Component Video

ABSOLUTE MAXIMUM RATINGS

V_{CC} to GND+6V
 All Other Pins to GND-0.3V to (V_{CC} + 0.3V)
 Maximum Current into Any Pin Except V_{CC} and GND±50mA
 Continuous Power Dissipation (T_A = +70°C)
 TSSOP-EP (derate 20.8mW/°C above +70°C)1667mW

Operating Temperature Range-40°C to +85°C
 Storage Temperature Range-65°C to +150°C
 Junction Temperature+150°C
 Lead Temperature (soldering, 10s)+300°C

Stresses beyond those listed under "Absolute Maximum Ratings" may cause permanent damage to the device. These are stress ratings only, and functional operation of the device at these or any other conditions beyond those indicated in the operational sections of the specifications is not implied. Exposure to absolute maximum rating conditions for extended periods may affect device reliability.

ELECTRICAL CHARACTERISTICS

(V_{CC} = +4.75V to +5.25V, C_L = 0 to 20pF, R_L = 75Ω to GND for DC-coupled load, R_L = 75Ω to V_{CC} / 2 for AC-coupled load, C_{IN} = 0.1μF, GAIN = +6dB, T_A = T_{MIN} to T_{MAX}, unless otherwise noted. Typical values are at V_{CC} = +5V, T_A = +25°C.)

PARAMETER	SYMBOL	CONDITIONS	MIN	TYP	MAX	UNITS
Passband Response		f = 100kHz to 5MHz, relative to 100kHz, channels A, B, C	-0.75	+0.15	+0.75	dB
Stopband Attenuation	A _{SB}	f ≥ 27MHz	39	43		dB
Differential Gain	dG	5-step modulated staircase		0.15	0.50	%
Differential Phase	dθ	5-step modulated staircase		0.15	0.50	Degrees
Signal-to-Noise Ratio	SNR	Peak signal (2V _{P-P}) to RMS noise, f = 100Hz to 50MHz		80		dB
Group Delay Deviation	Δt _g	Deviation from 100kHz to 4.1MHz		11	20	ns
Line-Time Distortion	H _{DIST}	18μs, 100 IRE bar			0.3	%
Field-Time Distortion	V _{DIST}	130 lines, 18μs, 100 IRE bar			0.5	%
Clamp Settling Time	t _{CLAMP}	To ±1%		430		Lines
Output DC Clamp Level		Channels A, B, C	1.1	1.5	1.8	V
Low-Frequency Gain Accuracy	A _v	f = 100kHz	-3		+3	%
Low-Frequency Gain Matching	A _v (MATCH)	Low-frequency channel-to-channel matching, f = 100kHz			4	%
Group Delay Matching	t _g (MATCH)	Low-frequency channel-to-channel matching, f = 100kHz		2		ns
Channel-to-Channel Crosstalk	X _{TALK}	f = 100kHz to 3.58MHz		60		dB
Output Short-Circuit Current	I _{SC}	OUT_ shorted to GND or V _{CC}		70		mA
Input Leakage Current	I _{IN}				10	μA
Input Dynamic Swing		Channels A, B, C			0.9	V _{P-P}
SUPPLY						
Supply Voltage Range	V _{CC}		4.75		5.25	V
Supply Current	I _{CC}	No load		75	100	mA
Power-Supply Rejection Ratio	PSRR	V _{IN} = 100mV _{P-P} , f = 0 to 3.5MHz		40		dB

3-Channel Video Reconstruction Filter for RGB Component Video

MAX7449

ELECTRICAL CHARACTERISTICS (continued)

($V_{CC} = +4.75V$ to $+5.25V$, $C_L = 0$ to $20pF$, $R_L = 75\Omega$ to GND for DC-coupled load, $R_L = 75\Omega$ to $V_{CC} / 2$ for AC-coupled load, $C_{IN_} = 0.1\mu F$, GAIN = +6dB, $T_A = T_{MIN}$ to T_{MAX} , unless otherwise noted. Typical values are at $V_{CC} = +5V$, $T_A = +25^\circ C$.)

PARAMETER	SYMBOL	CONDITIONS	MIN	TYP	MAX	UNITS
LOGIC INPUTS (DISABLE and EXTSYNC)						
Output Impedance During Disable	ZDISABLE	At 5MHz		2		k Ω
Logic-Input High Voltage	V _{IH}		2.0			V
Logic-Input Low Voltage	V _{IL}				0.8	V
Logic Input Current	I _{LOGIC}	V _{IL} = 0V (SINK), V _{IH} = V _{CC} (SOURCE)			±10	μA

Typical Operating Characteristics

($V_{CC} = +5V$, $T_A = +25^\circ C$, unless otherwise noted.)

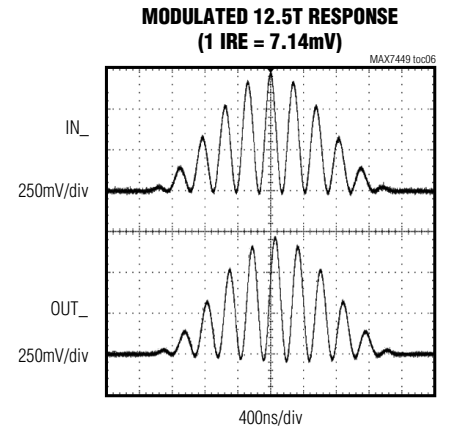
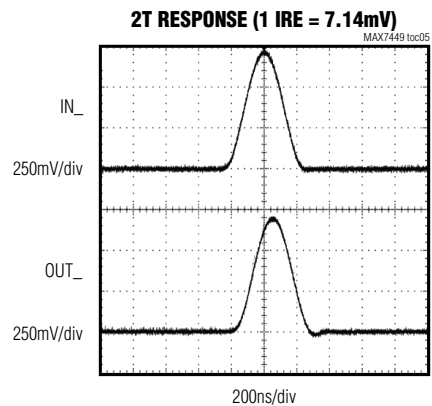
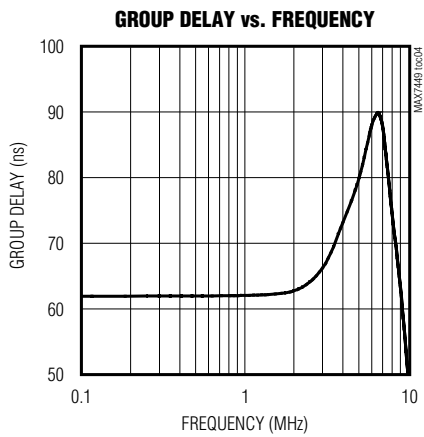
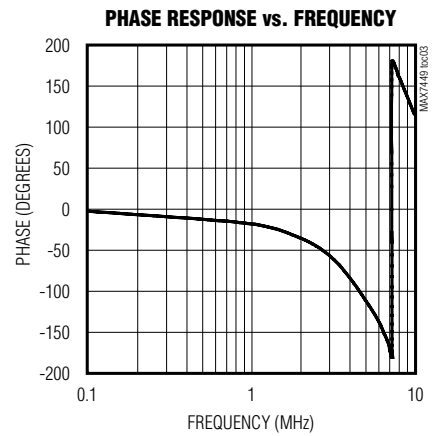
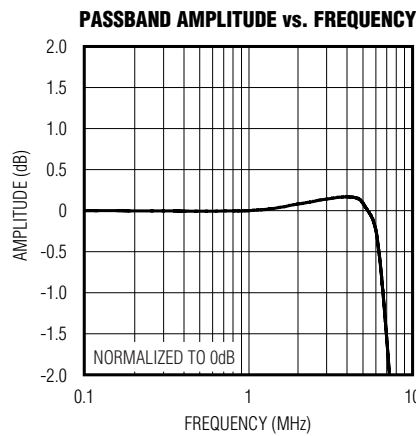
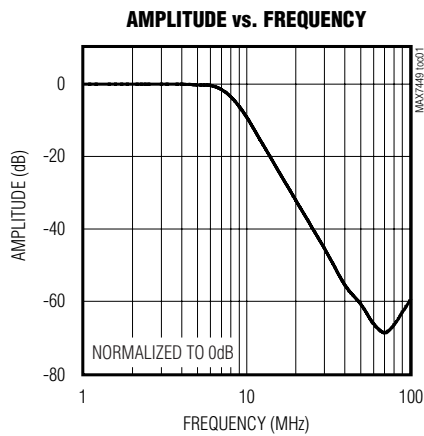

3-Channel Video Reconstruction Filter for RGB Component Video

Typical Operating Characteristics (continued)

(V_{CC} = +5V, T_A = +25°C, unless otherwise noted.)

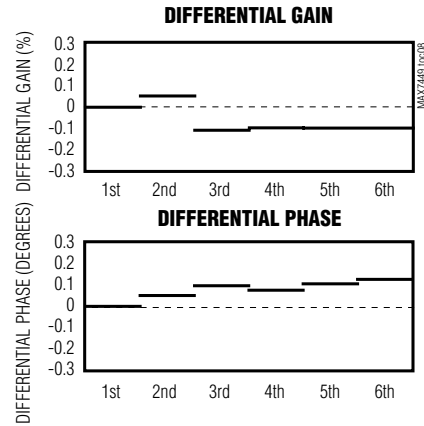
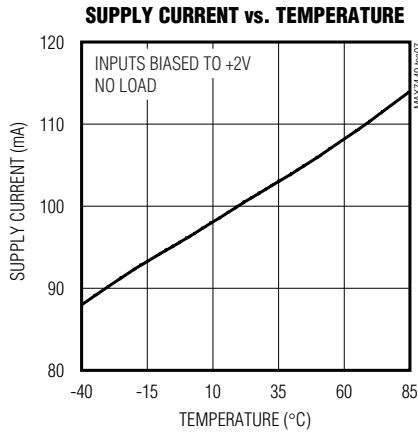

Pin Description

PIN	NAME	FUNCTION
1, 10	V _{CC}	+5V Supply Input
2	INA	Channel A Video Input. Use channel A for the red (R) video signal. AC-couple INA with a series 0.1μF capacitor.
3	INB	Channel B Video Input. Use channel B for the green (G) video signal. AC-couple INB with a series 0.1μF capacitor.
4	INC	Channel C Video Input. Use channel C for the blue (B) video signal. AC-couple INC with a series 0.1μF capacitor.
5	DISABLE	Disable Logic Input. Connect DISABLE to GND for normal operation. Connect DISABLE to V _{CC} to disable all buffer outputs and put them in a high-impedance state.
6	EXTSYNC	External Sync Input. Use TTL logic levels. A logic high enables the DC restore loop and clamps the output voltages to +1.5V (typ).
7, 8	GND	Ground
9, 14	N.C.	No Connection. Make no connection to these pins.
11	OUTC	Channel C Buffer Output. This output can be either AC- or DC-coupled.
12	OUTB	Channel B Buffer Output. This output can be either AC- or DC-coupled.
13	OUTA	Channel A Buffer Output. This output can be either AC- or DC-coupled.

3-Channel Video Reconstruction Filter for RGB Component Video

Detailed Description

The MAX7449 filters and buffers video-encoder DAC outputs in applications such as set-top boxes, HDRs, DVD players, and digital VCRs. The MAX7449 reconstructs and cleans up component RGB analog video signals. Each channel consists of a lowpass filter and an output video buffer that drives two standard 150Ω video loads.

This device operates from a single +5V supply and has a nominal cutoff frequency of 5MHz optimized for NTSC, PAL, and SDTV.

Filter

Filter Response

The reconstruction filter consists of two 2nd-order Sallen-Key stages. The Butterworth-type response features a maximally flat passband for NTSC and PAL bandwidths. The stopband offers at least 43dB (typ) of attenuation at a sampling frequency of ≥ 27 MHz (see the *Typical Operating Characteristics*).

Output Buffers

Each output buffer has a fixed gain of +6dB and can drive two 150Ω video loads with a 2V_{p-p} signal. The MAX7449 can drive an AC load or drive the video load directly without using a large output capacitor. The output buffers drive DC loads with an output blanking level of less than 1V.

Output Clamp Level

When a sync pulse is detected on EXTSYNC, the DC restore loop is activated for channels A, B, and C. The function of the loop is to set the DC level of the video signal to the desired level. See Table 1 for clamp levels.

Table 1. Output Clamp Level

CHANNEL	CLAMP LEVEL (V)
A	1.5
B	1.5
C	1.5

Applications Information

Input Considerations

Use 0.1μF ceramic capacitors to AC-couple the inputs. These input capacitors store a DC level so the outputs are clamped to an appropriate DC voltage level. The MAX7449 allows R, G, or B video signals to be processed by any channel. G must not have sync information.

Output Considerations

The outputs are typically connected to a 75Ω series back-match resistor followed by the video cable. Because of the inherent divide-by-two of this configuration, the voltage on the video cable is always less than 1V, complying with industry-standard video requirements such as the European SCART standard (which allows up to 2V of DC on the video cable). The video buffer can also drive an AC-coupled video load. Good video performance is achieved with an output capacitor as low as 220μF.

Power-Supply Bypassing and Layout

The MAX7449 operates from a single +5V supply. Bypass V_{CC} to GND with a 0.1μF capacitor. Place all external components as close to the device as possible.

Exposed Pads

The TSSOP-EP package has an exposed pad on the bottom of the package. This pad is electrically connected to GND and should be connected to the ground plane for improved thermal conductivity. Do not route signals under this package.

Pin Configuration

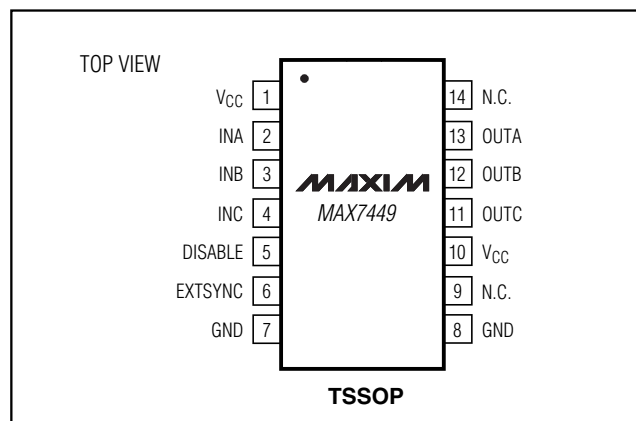

Chip Information

TRANSISTOR COUNT: 6300

PROCESS: BICMOS

3-Channel Video Reconstruction Filter for RGB Component Video

Package Information

(The package drawing(s) in this data sheet may not reflect the most current specifications. For the latest package outline information, go to www.maxim-ic.com/packages.)

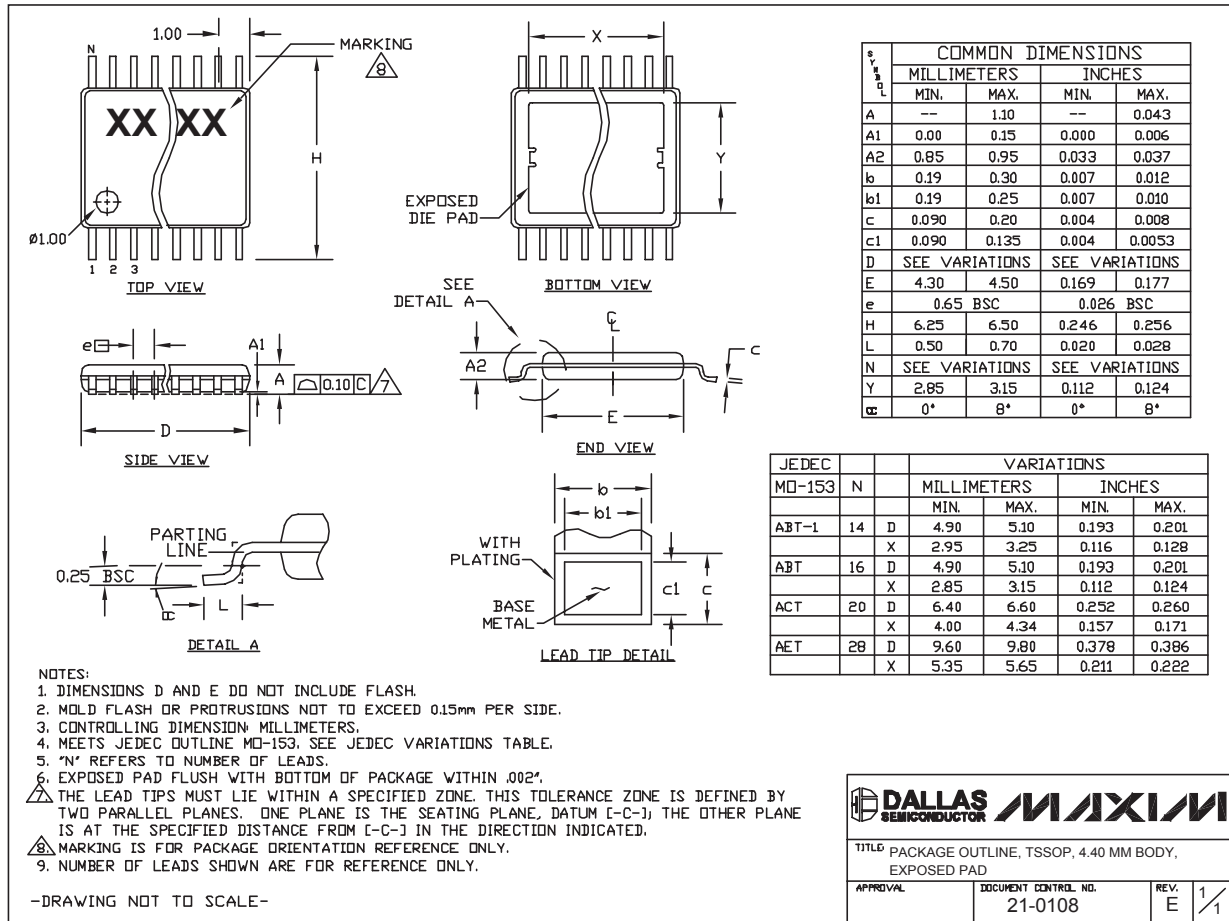

TSSOP 4.4mm BODY EPS

Maxim cannot assume responsibility for use of any circuitry other than circuitry entirely embodied in a Maxim product. No circuit patent licenses are implied. Maxim reserves the right to change the circuitry and specifications without notice at any time.

6 **Maxim Integrated Products, 120 San Gabriel Drive, Sunnyvale, CA 94086 408-737-7600**

Looking for pricing, stock, or lifecycle information?

Click below to explore more details on WIN SOURCE:

 [View MAX7449EUD-T on WIN SOURCE](#)

 [Maxim Integrated](#) Information

Optimize Your Supply Chain with WIN SOURCE Solutions

-  Global Sourcing Solution
-  Obsolete Management
-  Cost Control Management
-  Shortage Management
-  Alternative Solution
-  Excess Inventory Management