



**THE DATASHEET OF  
MAX7405ESA+T**





## 8th-Order, Lowpass, Bessel, Switched-Capacitor Filters

MAX7401/MAX7405

### General Description

The MAX7401/MAX7405 8th-order, lowpass, Bessel, switched-capacitor filters (SCFs) operate from a single +5V (MAX7401) or +3V (MAX7405) supply. These devices draw only 2mA of supply current and allow corner frequencies from 1Hz to 5kHz, making them ideal for low-power post-DAC filtering and anti-aliasing applications. They feature a shutdown mode that reduces supply current to 0.2 $\mu$ A.

Two clocking options are available on these devices: self-clocking (through the use of an external capacitor) or external clocking for tighter corner-frequency control. An offset adjust pin allows for adjustment of the DC output level.

The MAX7401/MAX7405 Bessel filters provide low overshoot and fast settling. Their fixed response simplifies the design task to selecting a clock frequency.

### Applications

ADC Anti-Aliasing                      CT2 Base Stations  
 Post-DAC Filtering                      Speech Processing  
 Air-Bag Electronics

### Pin Configuration

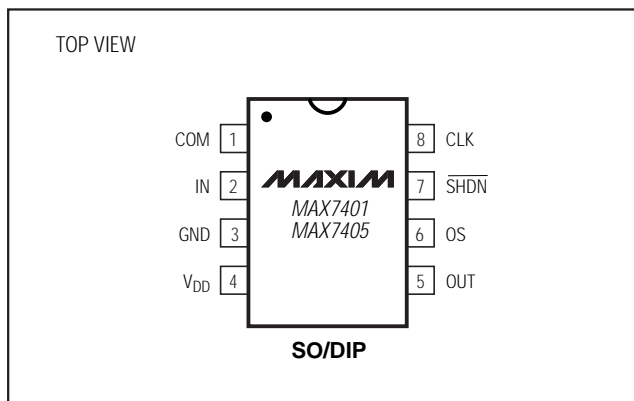

### Features

- ◆ 8th-Order, Lowpass Bessel Filters
- ◆ Low Noise and Distortion: -82dB THD + Noise
- ◆ Clock-Tunable Corner Frequency (1Hz to 5kHz)
- ◆ 100:1 Clock-to-Corner Ratio
- ◆ Single-Supply Operation
  - +5V (MAX7401)
  - +3V (MAX7405)
- ◆ Low Power
  - 2mA (Operating Mode)
  - 0.2 $\mu$ A (Shutdown Mode)
- ◆ Available in 8-Pin SO/DIP Packages
- ◆ Low Output Offset:  $\pm$ 5mV

### Ordering Information

PART	TEMP. RANGE	PIN-PACKAGE
MAX7401CSA	0°C to +70°C	8 SO
MAX7401CPA	0°C to +70°C	8 Plastic DIP
MAX7401ESA	-40°C to +85°C	8 SO
MAX7401EPA	-40°C to +85°C	8 Plastic DIP
MAX7405CSA	0°C to +70°C	8 SO
MAX7405CPA	0°C to +70°C	8 Plastic DIP
MAX7405ESA	-40°C to +85°C	8 SO
MAX7405EPA	-40°C to +85°C	8 Plastic DIP

### Typical Operating Circuit

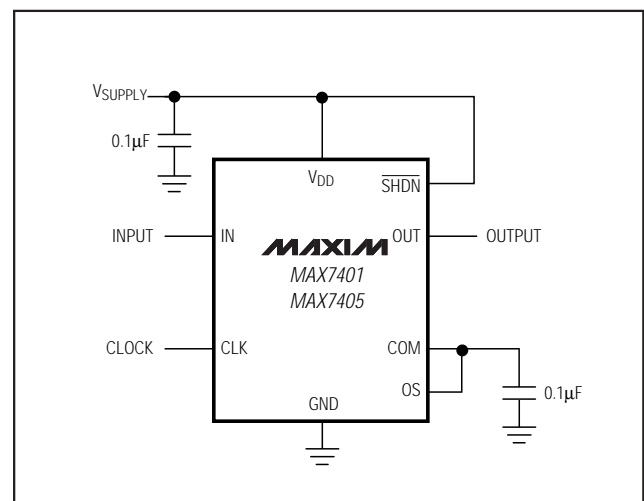

# 8th-Order, Lowpass, Bessel, Switched-Capacitor Filters

## ABSOLUTE MAXIMUM RATINGS

$V_{DD}$ to GND		Continuous Power Dissipation ( $T_A = +70^\circ\text{C}$ )	
MAX7401 .....	-0.3V to +6V	8-Pin SO (derate 5.88mW/ $^\circ\text{C}$ above $+70^\circ\text{C}$ ).....471mW	
MAX7405 .....	-0.3V to +4V	8-Pin DIP (derate 9.09mW/ $^\circ\text{C}$ above $+70^\circ\text{C}$ ).....727mW	
IN, OUT, COM, OS, CLK .....	-0.3V to ( $V_{DD} + 0.3\text{V}$ )	Operating Temperature Ranges	
SHDN.....	-0.3V to +6V	MAX740 _C_A .....	0 $^\circ\text{C}$ to $+70^\circ\text{C}$
OUT Short-Circuit Duration.....	1sec	MAX740 _E_A .....	-40 $^\circ\text{C}$ to $+85^\circ\text{C}$
		Storage Temperature Range .....	-65 $^\circ\text{C}$ to $+150^\circ\text{C}$
		Lead Temperature (soldering, 10sec) .....	$+300^\circ\text{C}$

Stresses beyond those listed under "Absolute Maximum Ratings" may cause permanent damage to the device. These are stress ratings only, and functional operation of the device at these or any other conditions beyond those indicated in the operational sections of the specifications is not implied. Exposure to absolute maximum rating conditions for extended periods may affect device reliability.

## ELECTRICAL CHARACTERISTICS—MAX7401

( $V_{DD} = +5\text{V}$ , filter output measured at OUT,  $10\text{k}\Omega \parallel 50\text{pF}$  load to GND at OUT, OS = COM,  $0.1\mu\text{F}$  from COM to GND, SHDN =  $V_{DD}$ ,  $f_{\text{CLK}} = 100\text{kHz}$ ,  $T_A = T_{\text{MIN}}$  to  $T_{\text{MAX}}$ , unless otherwise noted. Typical values are at  $T_A = +25^\circ\text{C}$ .)

PARAMETER	SYMBOL	CONDITIONS	MIN	TYP	MAX	UNITS
<b>FILTER CHARACTERISTICS</b>						
Corner Frequency	$f_C$	(Note 1)		0.001 to 5		kHz
Clock-to-Corner Ratio	$f_{\text{CLK}} / f_C$			100:1		
Clock-to-Corner Tempco				10		ppm/ $^\circ\text{C}$
Output Voltage Range			0.25	$V_{DD} - 0.25$		V
Output Offset Voltage	$V_{\text{OFFSET}}$	$V_{\text{IN}} = V_{\text{COM}} = V_{DD} / 2$		$\pm 5$	$\pm 25$	mV
DC Insertion Gain with Output Offset Removed		$V_{\text{COM}} = V_{DD} / 2$ (Note 2)	-0.1	0.15	0.3	dB
Total Harmonic Distortion plus Noise	THD+N	$f_{\text{IN}} = 200\text{Hz}$ , $V_{\text{IN}} = 4\text{Vp-p}$ , measurement bandwidth = 22kHz		-82		dB
OS Voltage Gain to OUT	$A_{\text{OS}}$			1		V/V
Input Voltage Range at OS	$V_{\text{OS}}$			$V_{\text{COM}} \pm 0.1$		V
COM Voltage Range	$V_{\text{COM}}$	Input, COM externally driven	$V_{DD} / 2 - 0.5$	$V_{DD} / 2$	$V_{DD} / 2 + 0.5$	V
		Output, COM internally biased	$V_{DD} / 2 - 0.2$	$V_{DD} / 2$	$V_{DD} / 2 + 0.2$	
Input Resistance at COM	$R_{\text{COM}}$		75	125		$\text{k}\Omega$
Clock Feedthrough				10		mVp-p
Resistive Output Load Drive	$R_L$		10	1		$\text{k}\Omega$
Maximum Capacitive Load at OUT	$C_L$		50	500		pF
Input Leakage Current at COM		SHDN = GND, $V_{\text{COM}} = 0$ to $V_{DD}$		$\pm 0.1$	$\pm 10$	$\mu\text{A}$
Input Leakage Current at OS		$V_{\text{OS}} = 0$ to ( $V_{DD} - 1\text{V}$ ) (Note 3)		$\pm 0.1$	$\pm 10$	$\mu\text{A}$
<b>CLOCK</b>						
Internal Oscillator Frequency	$f_{\text{OSC}}$	$C_{\text{OSC}} = 1000\text{pF}$ (Note 4)	29	38	48	kHz
Clock Input Current	$I_{\text{CLK}}$	$V_{\text{CLK}} = 0$ or 5V		$\pm 15$	$\pm 30$	$\mu\text{A}$
Clock Input High	$V_{\text{IH}}$		$V_{DD} - 0.5$			V
Clock Input Low	$V_{\text{IL}}$				0.5	V

# 8th-Order, Lowpass, Bessel, Switched-Capacitor Filters

MAX7401/MAX7405

## ELECTRICAL CHARACTERISTICS—MAX7401 (continued)

( $V_{DD} = +5V$ , filter output measured at OUT,  $10k\Omega \parallel 50pF$  load to GND at OUT, OS = COM,  $0.1\mu F$  from COM to GND,  $\overline{SHDN} = V_{DD}$ ,  $f_{CLK} = 100kHz$ ,  $T_A = T_{MIN}$  to  $T_{MAX}$ , unless otherwise noted. Typical values are at  $T_A = +25^\circ C$ .)

PARAMETER	SYMBOL	CONDITIONS	MIN	TYP	MAX	UNITS
<b>POWER REQUIREMENTS</b>						
Supply Voltage	$V_{DD}$		4.5		5.5	V
Supply Current	$I_{DD}$	Operating mode, no load, IN = OS = COM		2	3.5	mA
Shutdown Current	$I_{\overline{SHDN}}$	$\overline{SHDN} = GND$ , CLK driven from 0 to $V_{DD}$		0.2	1	$\mu A$
Power-Supply Rejection Ratio	PSRR	Measured at DC		60		dB
<b>SHUTDOWN</b>						
$\overline{SHDN}$ Input High	$V_{SDH}$		$V_{DD} - 0.5$			V
$\overline{SHDN}$ Input Low	$V_{SDL}$				0.5	V
$\overline{SHDN}$ Input Leakage Current		$V_{\overline{SHDN}} = 0$ to $V_{DD}$		$\pm 0.1$	$\pm 10$	$\mu A$

## ELECTRICAL CHARACTERISTICS—MAX7405

( $V_{DD} = +3V$ , filter output measured at OUT,  $10k\Omega \parallel 50pF$  load to GND at OUT, OS = COM,  $0.1\mu F$  from COM to GND,  $\overline{SHDN} = V_{DD}$ ,  $f_{CLK} = 100kHz$ ,  $T_A = T_{MIN}$  to  $T_{MAX}$ , unless otherwise noted. Typical values are at  $T_A = +25^\circ C$ .)

PARAMETER	SYMBOL	CONDITIONS	MIN	TYP	MAX	UNITS
<b>FILTER CHARACTERISTICS</b>						
Corner Frequency	$f_C$	(Note 1)		0.001 to 5		kHz
Clock-to-Corner Ratio	$f_{CLK}/f_C$			100:1		
Clock-to-Corner Tempco				10		ppm/ $^\circ C$
Output Voltage Range			0.25	$V_{DD} - 0.25$		V
Output Offset Voltage	$V_{OFFSET}$	$V_{IN} = V_{COM} = V_{DD} / 2$		$\pm 5$	$\pm 25$	mV
DC Insertion Gain with Output Offset Removed		$V_{COM} = V_{DD} / 2$ (Note 2)	-0.1	0.03	0.3	dB
Total Harmonic Distortion plus Noise	THD+N	$f_{IN} = 200Hz$ , $V_{IN} = 2.5V_{p-p}$ , measurement bandwidth = 22kHz		-84		dB
OS Voltage Gain to OUT	$A_{OS}$			1		V/V
Input Voltage Range at OS	$V_{OS}$			$V_{COM} \pm 0.1$		V
COM Voltage Range	$V_{COM}$	COM internally biased or externally driven	$V_{DD} / 2 - 0.1$	$V_{DD} / 2$	$V_{DD} / 2 + 0.1$	V
Input Resistance at COM	$R_{COM}$		75	125		$k\Omega$
Clock Feedthrough				10		mVp-p
Resistance Output Load Drive	$R_L$		10	1		$k\Omega$
Maximum Capacitive Load at OUT	$C_L$		50	500		pF
Input Leakage Current at COM		$\overline{SHDN} = GND$ , $V_{COM} = 0$ to $V_{DD}$		$\pm 0.1$	$\pm 10$	$\mu A$
Input Leakage Current at OS		$V_{OS} = 0$ to $(V_{DD} - 1V)$ (Note 3)		$\pm 0.1$	$\pm 10$	$\mu A$

# 8th-Order, Lowpass, Bessel, Switched-Capacitor Filters

## ELECTRICAL CHARACTERISTICS—MAX7405 (continued)

( $V_{DD} = +3V$ , filter output measured at OUT,  $10k\Omega \parallel 50pF$  load to GND at OUT, OS = COM,  $0.1\mu F$  from COM to GND,  $\overline{SHDN} = V_{DD}$ ,  $f_{CLK} = 100kHz$ ,  $T_A = T_{MIN}$  to  $T_{MAX}$ , unless otherwise noted. Typical values are at  $T_A = +25^\circ C$ .)

PARAMETER	SYMBOL	CONDITIONS	MIN	TYP	MAX	UNITS
<b>CLOCK</b>						
Internal Oscillator Frequency	$f_{OSC}$	$C_{OSC} = 1000pF$ (Note 4)	26	34	43	kHz
Clock Input Current	$I_{CLK}$	$V_{CLK} = 0$ or $3V$		$\pm 15$	$\pm 30$	$\mu A$
Clock Input High	$V_{IH}$		$V_{DD} - 0.5$			V
Clock Input Low	$V_{IL}$				0.5	V
<b>POWER REQUIREMENTS</b>						
Supply Voltage	$V_{DD}$		2.7		3.6	V
Supply Current	$I_{DD}$	Operating mode, no load, IN = OS = COM		2	3.5	mA
Shutdown Current	$I_{\overline{SHDN}}$	$\overline{SHDN} = GND$ , CLK driven from 0 to $V_{DD}$		0.2	1	$\mu A$
Power-Supply Rejection Ratio	PSRR	Measured at DC		60		dB
<b>SHUTDOWN</b>						
$\overline{SHDN}$ Input High	$V_{SDH}$		$V_{DD} - 0.5$			V
$\overline{SHDN}$ Input Low	$V_{SDL}$				0.5	V
$\overline{SHDN}$ Input Leakage Current		$V_{\overline{SHDN}} = 0$ to $V_{DD}$		$\pm 0.1$	$\pm 10$	$\mu A$

## FILTER CHARACTERISTICS—MAX7401/MAX7405

( $V_{DD} = +5V$  for MAX7401,  $V_{DD} = +3V$  for MAX7405; filter output measured at OUT;  $10k\Omega \parallel 50pF$  load to GND at OUT;  $\overline{SHDN} = V_{DD}$ ;  $V_{COM} = V_{OS} = V_{DD}/2$ ;  $f_{CLK} = 100kHz$ ;  $T_A = T_{MIN}$  to  $T_{MAX}$ ; unless otherwise noted. Typical values are at  $T_A = +25^\circ C$ .)

PARAMETER	CONDITIONS	MIN	TYP	MAX	UNITS
Insertion Gain Relative to DC Gain	$f_{IN} = 0.5f_C$	-1.0	-0.8	-0.6	dB
	$f_{IN} = f_C$	-3.3	-3.0	-2.7	
	$f_{IN} = 3f_C$		-33	-29	
	$f_{IN} = 6f_C$		-79	-74	

**Note 1:** The maximum  $f_C$  is defined as the clock frequency,  $f_{CLK} = 100 \cdot f_C$ , at which the peak SINAD drops to 68dB with a sinusoidal input at  $0.2f_C$ .

**Note 2:** DC insertion gain is defined as  $\Delta V_{OUT} / \Delta V_{IN}$ .

**Note 3:** OS voltages above  $V_{DD} - 1V$  saturate the input and result in a  $75\mu A$  typical input leakage current.

**Note 4:** For MAX7401,  $f_{OSC} (kHz) \approx 38 \cdot 10^3 / C_{OSC} (pF)$ . For MAX7405,  $f_{OSC} (kHz) \approx 34 \cdot 10^3 / C_{OSC} (pF)$ .

# 8th-Order, Lowpass, Bessel, Switched-Capacitor Filters

MAX7401/MAX7405

## Typical Operating Characteristics

( $V_{DD} = +5V$  for MAX7401,  $V_{DD} = +3V$  for MAX7405;  $f_{CLK} = 100kHz$ ;  $\overline{SHDN} = V_{DD}$ ;  $V_{COM} = V_{OS} = V_{DD} / 2$ ;  $T_A = +25^\circ C$ ; unless otherwise noted.)

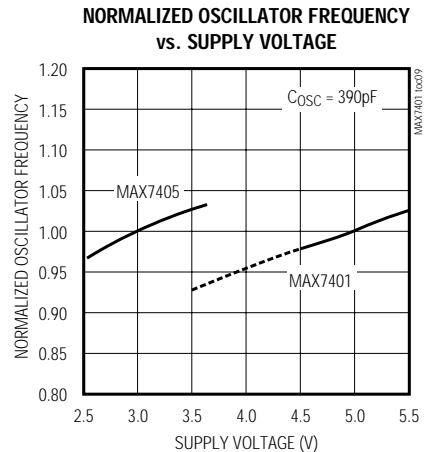
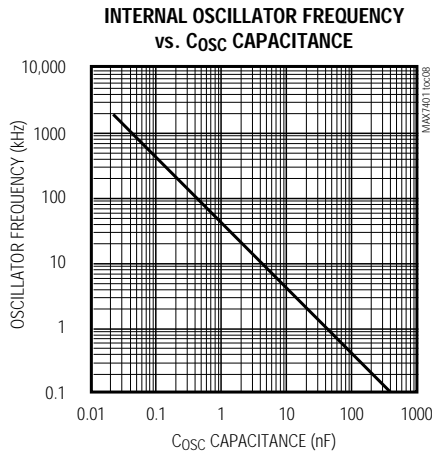
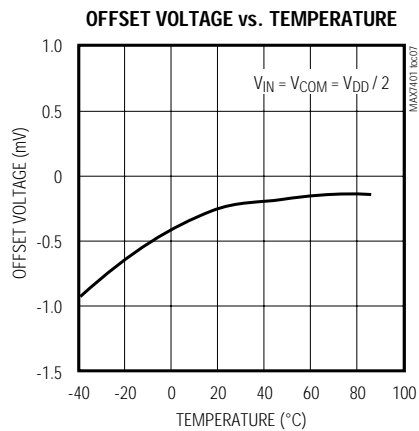
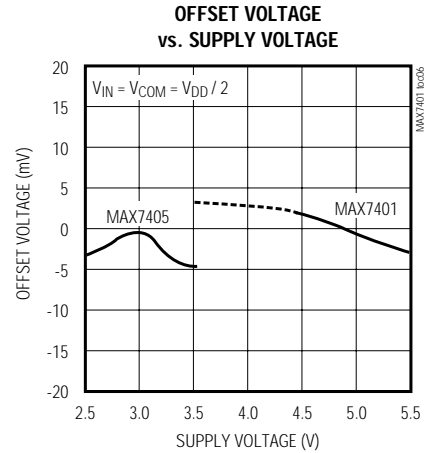
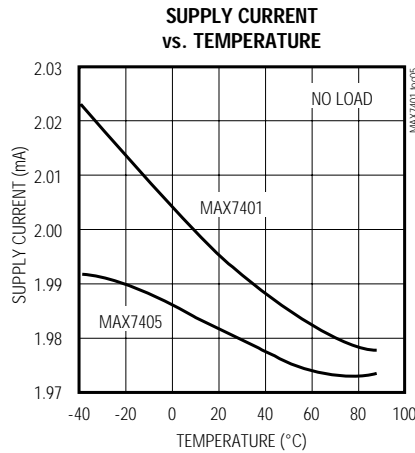
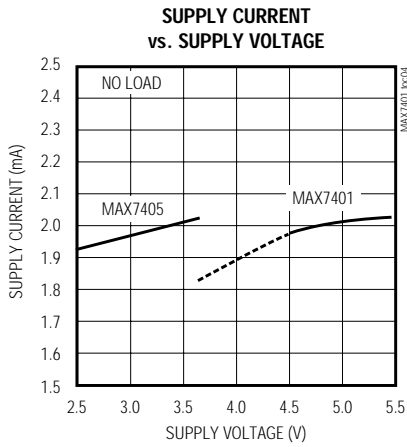
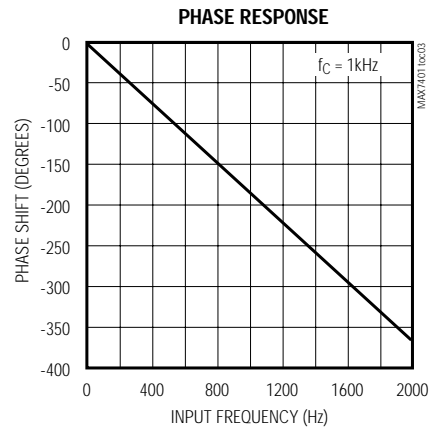
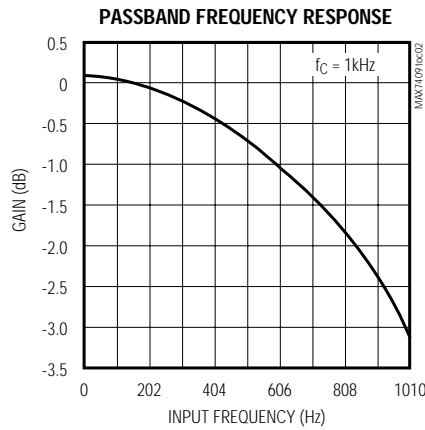
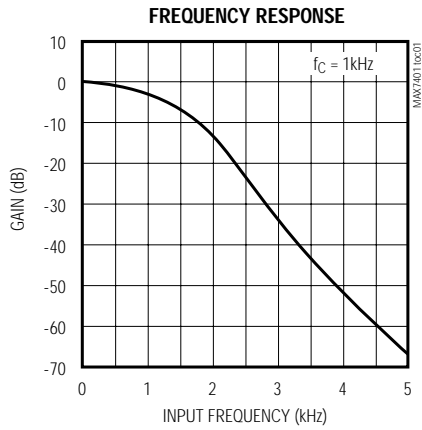

# 8th-Order, Lowpass, Bessel, Switched-Capacitor Filters

## Typical Operating Characteristics (continued)

( $V_{DD} = +5V$  for MAX7401,  $V_{DD} = +3V$  for MAX7405;  $f_{CLK} = 100kHz$ ;  $\overline{SHDN} = V_{DD}$ ;  $V_{COM} = V_{OS} = V_{DD} / 2$ ;  $T_A = +25^\circ C$ ; unless otherwise noted.)

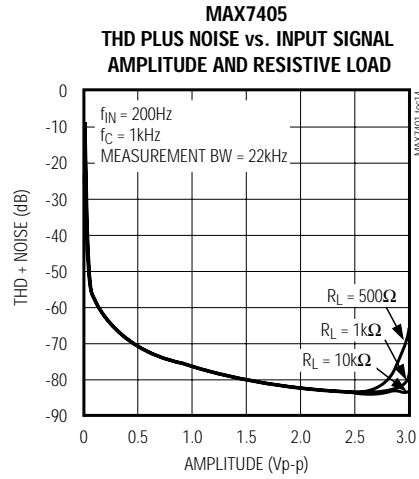
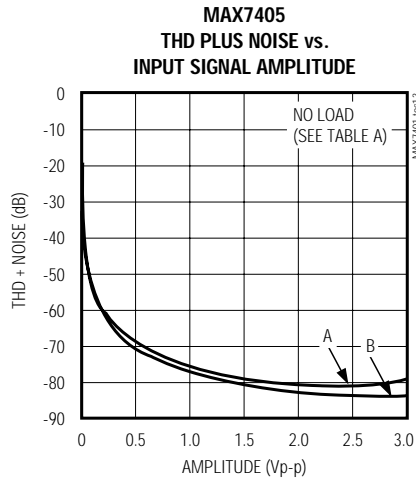
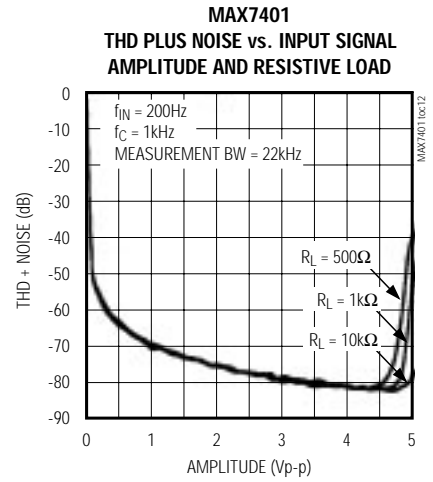
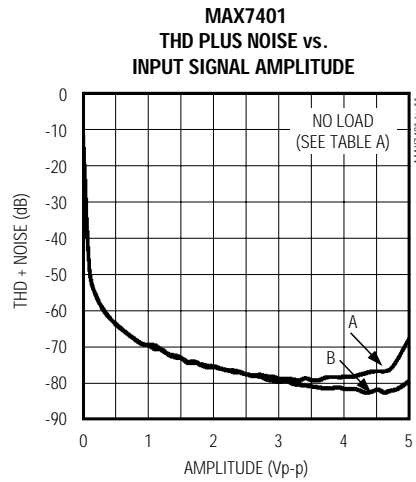
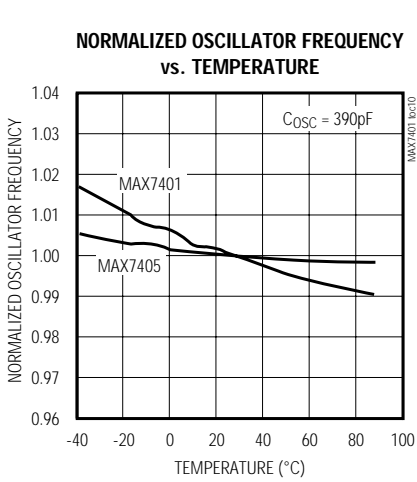

**Table A. THD Plus Noise vs. Input Signal Amplitude Test Conditions**

TRACE	$f_{IN}$ (Hz)	$f_C$ (kHz)	$f_{CLK}$ (kHz)	MEASUREMENT BANDWIDTH (kHz)
A	1000	5	500	80
B	200	1	100	22

# 8th-Order, Lowpass, Bessel, Switched-Capacitor Filters

## Pin Description

PIN	NAME	FUNCTION
1	COM	Common Input. Biased internally at mid-supply. Bypass externally to GND with a 0.1 $\mu$ F capacitor. To override internal biasing, drive with an external supply.
2	IN	Filter Input
3	GND	Ground
4	V <sub>DD</sub>	Positive Supply Input: +5V for MAX7401, +3V for MAX7405
5	OUT	Filter Output
6	OS	Offset Adjust Input. To adjust output offset, bias OS externally. Connect OS to COM if no offset adjustment is needed. Refer to <i>Offset and Common-Mode Input Adjustment</i> section.
7	$\overline{\text{SHDN}}$	Shutdown Input. Drive low to enable shutdown mode; drive high or connect to V <sub>DD</sub> for normal operation.
8	CLK	Clock Input. To override the internal oscillator, connect to an external clock; otherwise, connect an external capacitor (C <sub>OSC</sub> ) from CLK to GND to set the internal oscillator frequency.

## Detailed Description

The MAX7401/MAX7405 Bessel filters provide low overshoot and fast settling responses. Both parts operate with a 100:1 clock-to-corner frequency ratio and a 5kHz maximum corner frequency.

Lowpass Bessel filters such as the MAX7401/MAX7405 delay all frequency components equally, preserving the shape of step inputs (subject to the attenuation of the higher frequencies). Bessel filters settle quickly—an important characteristic in applications that use a multiplexer (mux) to select an input signal for an analog-to-digital converter (ADC). An anti-aliasing filter placed between the mux and the ADC must settle quickly after a new channel is selected.

Figure 1 shows the difference between Bessel and Butterworth filters when a 1kHz square wave is applied to the filter input. With the filter cutoff frequencies set at 5kHz, trace B shows the Bessel filter response and trace C shows the Butterworth filter response.

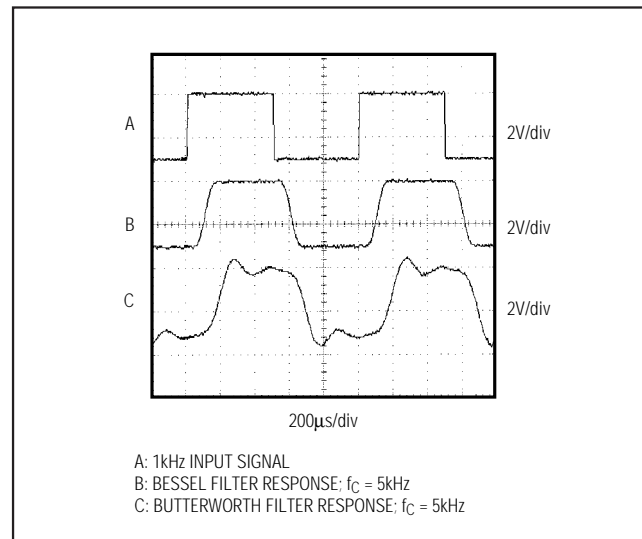

Figure 1. Bessel vs. Butterworth Filter Response

## Background Information

Most switched-capacitor filters (SCFs) are designed with biquadratic sections. Each section implements two filtering poles, and the sections are cascaded to produce higher order filters. The advantage to this approach is ease of design. However, this type of design is highly sensitive to component variations if any section's Q is high. An alternative approach is to emulate a passive network using switched-capacitor integrators with summing and scaling. Figure 2 shows a basic 8th-order ladder filter structure.

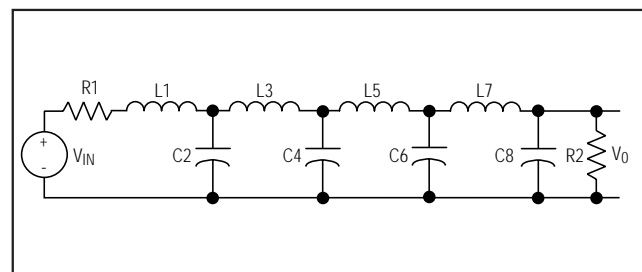

Figure 2. 8th-Order Ladder Filter Network

# 8th-Order, Lowpass, Bessel, Switched-Capacitor Filters

A switched-capacitor filter such as the MAX7401/MAX7405 emulates a passive ladder filter. The filter's component sensitivity is low when compared to a cascaded biquad design because each component affects the entire filter shape, not just one pole-zero pair. In other words, a mismatched component in a biquad design will have a concentrated error on its respective poles, while the same mismatch in a ladder filter design results in an error distributed over all poles.

## Clock Signal

### External Clock

The MAX7401/MAX7405 family of SCFs is designed for use with external clocks that have a 40% to 60% duty cycle. When using an external clock with these devices, drive CLK with a CMOS gate powered from 0 to  $V_{DD}$ . Varying the rate of the external clock adjusts the corner frequency of the filter as follows:

$$f_C = f_{CLK} / 100$$

### Internal Clock

When using the internal oscillator, connect a capacitor ( $C_{OSC}$ ) between CLK and ground. The value of the capacitor determines the oscillator frequency as follows:

$$f_{OSC} (\text{kHz}) = \frac{K \cdot 10^3}{C_{OSC}} ; C_{OSC} \text{ in pF}$$

where  $K = 38$  for MAX7401 and  $K = 34$  for MAX7405.

Minimize the stray capacitance at CLK so that it does not affect the internal oscillator frequency. Vary the rate of the internal oscillator to adjust the filter's corner frequency by a 100:1 clock-to-corner frequency ratio. For example, an internal oscillator frequency of 100kHz produces a nominal corner frequency of 1kHz.

### Input Impedance vs. Clock Frequencies

The MAX7401/MAX7405's input impedance is effectively that of a switched-capacitor resistor and is inversely proportional to frequency. The input impedance values determined below represent the average input impedance since the input current is not continuous. As a rule, use a driver with an output impedance less than 10% of the filter's input impedance. Estimate the input impedance of the filter using the following formula:

$$Z_{IN} = \frac{1}{(f_{CLK} \cdot C_{IN})}$$

where  $f_{CLK}$  = clock frequency and  $C_{IN} = 3.37\text{pF}$ .

## Low-Power Shutdown Mode

These devices feature a shutdown mode that is activated by driving SHDN low. In shutdown mode, the filter's supply current reduces to  $0.2\mu\text{A}$  (typ) and its output becomes high impedance. For normal operation, drive SHDN high or connect to  $V_{DD}$ .

## Applications Information

### Offset and Common-Mode Input Adjustment

The voltage at COM sets the common-mode input voltage and is biased at mid-supply with an internal resistor-divider. Bypass COM with a  $0.1\mu\text{F}$  capacitor and connect OS to COM. For applications requiring offset adjustment or DC level shifting, apply an external bias voltage through a resistor-divider network to OS, as shown in Figure 3. (Note: Do not leave OS unconnected.) The output voltage is represented by this equation:

$$V_{OUT} = (V_{IN} - V_{COM}) + V_{OS}$$

with  $V_{COM} = V_{DD} / 2$  (typical), and where  $(V_{IN} - V_{COM})$  is lowpass filtered by the SCF, and  $V_{OS}$  is added at the output stage. See the *Electrical Characteristics* for the voltage range of COM and OS. Changing the voltage on COM or OS significantly from mid-supply reduces the filter's dynamic range.

### Power Supplies

The MAX7401 operates from a single +5V supply, and the MAX7405 operates from a single +3V supply. Bypass  $V_{DD}$  to GND with a  $0.1\mu\text{F}$  capacitor. If dual supplies are required ( $\pm 2.5\text{V}$  for MAX7401,  $\pm 1.5\text{V}$  for MAX7405), connect COM to system ground and connect

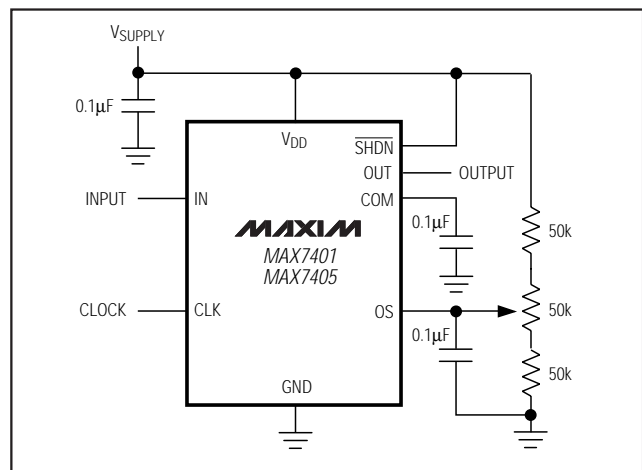

Figure 3. Offset Adjustment Circuit

# 8th-Order, Lowpass, Bessel, Switched-Capacitor Filters

**Table 1. Typical Harmonic Distortion**

FILTER	f <sub>CLK</sub> (kHz)	f <sub>c</sub> (kHz)	f <sub>IN</sub> (Hz)	V <sub>IN</sub> (Vp-p)	TYPICAL HARMONIC DISTORTION (dB)			
					2nd	3rd	4th	5th
MAX7401	100	1	200	4	-91	-83	-90	-93
	500	5	1000		-89	-79	-92	-92
MAX7405	100	1	200	2	-87	-83	-87	-88
	500	5	1000		-83	-82	-88	-88

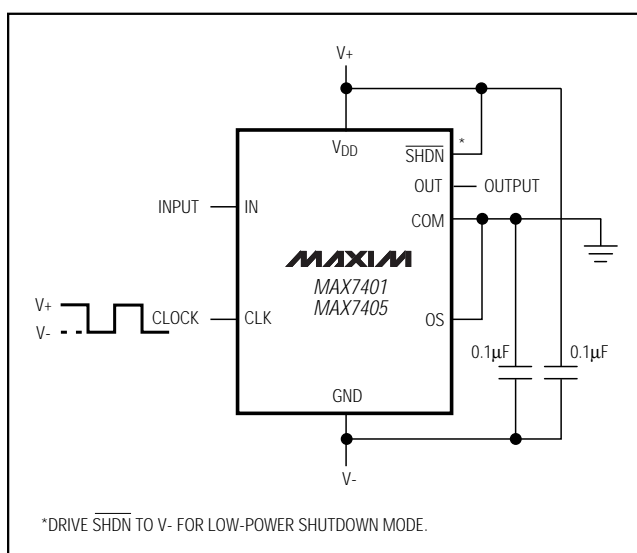

Figure 4. Dual-Supply Operation

GND to the negative supply. Figure 4 shows an example of dual-supply operation. Single- and dual-supply performance are equivalent. For either single- or dual-supply operation, drive CLK and SHDN from GND (V- in dual-supply operation) to V<sub>DD</sub>. For ±5V dual-supply applications, use the MAX291–MAX297.

### Input Signal Amplitude Range

The optimal input signal range is determined by observing the voltage level at which the total harmonic distortion plus noise (THD+N) is minimized for a given corner frequency. The *Typical Operating Characteristics* show graphs of the devices' THD+N response as the input signal's peak-to-peak amplitude is varied. These measurements are made with OS and COM biased at mid-supply.

### Anti-Aliasing and Post-DAC Filtering

When using the MAX7401/MAX7405 for anti-aliasing or post-DAC filtering, synchronize the DAC and the filter clocks. If the clocks are not synchronized, beat frequencies may alias into the passband.

The high clock-to-corner frequency ratio (100:1) also eases the requirements of pre- and post-SCF filtering. At the input, a lowpass filter prevents the aliasing of frequencies around the clock frequency into the passband. At the output, a lowpass filter attenuates the clock feedthrough.

A high clock-to-corner frequency ratio allows a simple RC lowpass filter, with the cutoff frequency set above the SCF corner frequency, to provide input anti-aliasing and reasonable output clock attenuation.

### Harmonic Distortion

Harmonic distortion arises from nonlinearities within the filter. These nonlinearities generate harmonics when a pure sine wave is applied to the filter input. Table 1 lists the MAX7401/MAX7405's typical harmonic-distortion values with a 10kΩ load at T<sub>A</sub> = +25°C.

## Chip Information

TRANSISTOR COUNT: 1116

# 8th-Order, Lowpass, Bessel, Switched-Capacitor Filters

## Package Information

INCHES		MILLIMETERS	
	MIN	MAX	
A	0.053	0.069	1.35 1.75
A1	0.004	0.010	0.10 0.25
B	0.014	0.019	0.35 0.49
C	0.007	0.010	0.19 0.25
e	0.050		1.27
E	0.150	0.157	3.80 4.00
H	0.228	0.244	5.80 6.20
h	0.010	0.020	0.25 0.50
L	0.016	0.050	0.40 1.27

INCHES		MILLIMETERS		N	MS012
	MIN	MAX			
D	0.189	0.197	4.80 5.00	8	A
D	0.337	0.344	8.55 8.75	14	B
D	0.386	0.394	9.80 10.00	16	C

NOTES:  
 1. D&E DO NOT INCLUDE MOLD FLASH  
 2. MOLD FLASH OR PROTRUSIONS NOT TO EXCEED .15mm (.006")  
 3. LEADS TO BE COPLANAR WITHIN .102mm (.004")  
 4. CONTROLLING DIMENSION: MILLIMETER  
 5. MEETS JEDEC MS012-XX AS SHOWN IN ABOVE TABLE  
 6. N = NUMBER OF PINS

**MAXIM** PACKAGE FAMILY OUTLINE: SOIC .150" 1/1 21-0041 A  
20 SAN CARLOS, CA 94065 FAX 415 737 7744 PROPRIETARY INFORMATION TITLE DOCUMENT CONTROL NUMBER REV



# 8th-Order, Lowpass, Bessel, Switched-Capacitor Filters

## NOTES

*Maxim cannot assume responsibility for use of any circuitry other than circuitry entirely embodied in a Maxim product. No circuit patent licenses are implied. Maxim reserves the right to change the circuitry and specifications without notice at any time.*

**12** \_\_\_\_\_ Maxim Integrated Products, 120 San Gabriel Drive, Sunnyvale, CA 94086 408-737-7600

## Looking for pricing, stock, or lifecycle information?

Click below to explore more details on WIN SOURCE:

 [View MAX7405ESA+T on WIN SOURCE](#)

 [Maxim Integrated](#) Information

## Optimize Your Supply Chain with WIN SOURCE Solutions

-  Global Sourcing Solution
-  Obsolete Management
-  Cost Control Management
-  Shortage Management
-  Alternative Solution
-  Excess Inventory Management