



**THE DATASHEET OF
MAX6966AEE+**



MAX6966/MAX6967

10-Port Constant-Current LED Drivers and I/O Expanders with PWM Intensity Control

General Description

The MAX6966/MAX6967 serial-interfaced peripherals provide microprocessors with 10 I/O ports rated to 7V.

Each port can be individually configured as either:

- A 20mA constant-current LED driver (static or pulse-width modulated (PWM)).
- A 10mA constant-current LED driver (static or PWM).
- An open-drain logic output.
- An overvoltage-protected Schmitt logic input.

Analog and switching LED intensity control is built in:

- Individual 8-bit PWM control per output.
- Individual 1-bit analog control (half/full) per output.
- Global 3-bit analog control applies to all LED outputs.

PWM timing of the 10 port outputs may be optionally staggered, consecutively phased in 45° increments. This spreads the PWM load currents over time in eight steps, helping to even out the power-supply current and reduce the RMS current.

The MAX6966/MAX6967 can be configured to awake from shutdown on receipt of a minimum 3ms pulse on the \overline{CS} input. This hardware-wakeup feature allows a power-management controller or similar ASIC to enable the MAX6966/MAX6967 with preconfigured LED intensity settings.

Shutdown can be programmed to wait up to 4s, fade down the sink currents to zero for a period of 1/16s to 4s, and then shut down. A similar ramp-up from shutdown can be programmed for 1/16s to 4s.

The MAX6966/MAX6967 support hot insertion. All port pins remain high impedance in power-down ($V_+ = 0V$) with up to 8V asserted on them.

The DOUT/OSC pin can be configured as either the serial interface data output or optional PWM clock input. The MAX6966 powers up defaulting as DOUT output. The MAX6967 defaults as OSC input.

For a similar part without the constant-current controls, refer to the MAX7317 data sheet.

Applications

LCD Backlights	RGB LED Drivers
Keypad Backlights	Portable Equipment
LED Status Indication	Cellular Phones

SPI and QSPI are trademarks of Motorola, Inc.

MICROWIRE is a trademark of National Semiconductor Corp.

Features

- ◆ High-Speed 26MHz SPI™/QSPI™/MICROWIRE™-Compatible Serial Interface
- ◆ 2.25V to 3.6V Operation
- ◆ I/O Ports Default to High-Z (LEDs Off) on Power-Up
- ◆ I/O Port Inputs Are Overvoltage Protected to 7V
- ◆ I/O Port Outputs Are 7V-Rated Open Drain
- ◆ I/O Port Outputs Are 10mA or 20mA Constant-Current Static/PWM LED Drivers, or Open-Drain Logic Outputs
- ◆ I/O Ports Support Hot Insertion
- ◆ Individual 8-Bit PWM Intensity Control for Each LED
- ◆ Any Output May Use or Not Use PWM Control
- ◆ Exit Shutdown (Warm Start) with Simple \overline{CS} Pulse
- ◆ Auto Ramp-Down into Shutdown
- ◆ Auto Ramp-Up Out from Shutdown
- ◆ 0.8 μ A (typ), 2 μ A (max) Shutdown Current
- ◆ Tiny 3mm x 3mm, 0.8mm High Thin QFN Package
- ◆ -40°C to +125°C Temperature Range

Ordering Information

PART	TEMP RANGE	PIN-PACKAGE	TOP MARK	PKG CODE
MAX6966ATE	-40°C to +125°C	16 Thin QFN 3mm x 3mm x 0.8mm	ACF	T1633-4
MAX6966AEE	-40°C to +125°C	16 QSOP	—	—
MAX6967ATE	-40°C to +125°C	16 Thin QFN 3mm x 3mm x 0.8mm	ACG	T1633-4
MAX6967AEE	-40°C to +125°C	16 QSOP	—	—

For pricing, delivery, and ordering information, please contact Maxim Direct at 1-888-629-4642, or visit Maxim's website at www.maximintegrated.com.

MAX6966/MAX6967

10-Port Constant-Current LED Drivers and I/O Expanders with PWM Intensity Control

ABSOLUTE MAXIMUM RATINGS

Voltage (with respect to GND)

V+	-0.3V to +4V
SCLK, DIN, \overline{CS} , DOUT/OSC	-0.3V to (V+ + 0.3V)
P ₋	-0.3V to +8V
DC Current into P ₋24mA
DC Current into DOUT/OSC	10mA
Total GND Current	280mA

Continuous Power Dissipation

16-Pin QSOP (derate 8.3mW/°C over T _A = +70°C)	667mW
16-Pin QFN (derate 14.7mW/°C over T _A = +70°C)....	1176mW
Operating Temperature Range (T _{MIN} to T _{MAX})	-40°C to +125°C
Junction Temperature	+150°C
Storage Temperature Range	-65°C to +150°C
Lead Temperature (soldering, 10s)	+300°C

Stresses beyond those listed under "Absolute Maximum Ratings" may cause permanent damage to the device. These are stress ratings only, and functional operation of the device at these or any other conditions beyond those indicated in the operational sections of the specifications is not implied. Exposure to absolute maximum rating conditions for extended periods may affect device reliability.

ELECTRICAL CHARACTERISTICS

(Typical Operating Circuit, V+ = 2.25V to 3.6V, T_A = T_{MIN} to T_{MAX}, unless otherwise noted. Typical values are at V+ = 3.3V, T_A = +25°C.) (Note 1)

PARAMETER	SYMBOL	CONDITIONS	MIN	TYP	MAX	UNITS
Operating Supply Voltage	V+		2.25		3.60	V
Output Load External Supply Voltage P0–P9	V _{EXT}				7	V
Standby Current (Interface Idle, CS Run Disabled, PWM Disabled, All Ports High Impedance)	I _{STBY}	\overline{CS} at V+; other digital inputs at V+ or GND	T _A = +25°C	0.7	1.5	μA
			T _A = T _{MIN} to +85°C		1.7	
			T _A = T _{MIN} to T _{MAX}		1.9	
Supply-Current Interface Only (CS Run Enabled, PWM Disabled, All Ports High Impedance)	I ₊	f _{SCLK} = 26MHz, other digital inputs at V+ or GND; DOUT unloaded	T _A = +25°C	390	620	μA
			T _A = T _{MIN} to +85°C		680	
			T _A = T _{MIN} to T _{MAX}		730	
Delta Supply Current per 10mA Port (Interface Idle, Global Current Register Set to 0x07, One Port's Output Register Set to 0x02 and Its Output Current Register Bit Cleared; All Other Ports' Output Registers Set to 0x00, 0x01, or 0xFF)	ΔI ₊₁₀	Digital inputs at V+ or GND	T _A = +25°C	1.58	1.8	mA
			T _A = T _{MIN} to +85°C		1.9	
			T _A = T _{MIN} to T _{MAX}		2	
Delta Supply Current per 20mA Port (Interface Idle, Global Current Register Set to 0x07, One Port's Output Register Set to 0x02 and Its Output Current Register Bit Set; All Other Ports' Output Registers Set to 0x00, 0x01, or 0xFF)	ΔI ₊₂₀	Digital inputs at V+ or GND	T _A = +25°C	3.2	3.6	mA
			T _A = T _{MIN} to +85°C		3.8	
			T _A = T _{MIN} to T _{MAX}		4.0	

MAX6966/MAX6967

10-Port Constant-Current LED Drivers and I/O Expanders with PWM Intensity Control

ELECTRICAL CHARACTERISTICS (continued)

(Typical Operating Circuit, $V_+ = 2.25V$ to $3.6V$, $T_A = T_{MIN}$ to T_{MAX} , unless otherwise noted. Typical values are at $V_+ = 3.3V$, $T_A = +25^\circ C$.) (Note 1)

PARAMETER	SYMBOL	CONDITIONS	MIN	TYP	MAX	UNITS	
Input High Voltage (P0–P9, DIN, SCLK, \overline{CS} , OSC)	V_{IH}	P0–P9: output register set to 0x01	0.7 x V_+			V	
Input Low Voltage (P0–P9, DIN, SCLK, \overline{CS} , OSC)	V_{IL}	P0–P9: output register set to 0x01			0.3 x V_+	V	
Input Leakage Current (P0–P9, DIN, SCLK, \overline{CS} , OSC)	I_{IH} , I_{IL}		-0.2		+0.2	μA	
Input Capacitance (P0–P9, DIN, SCLK, \overline{CS} , OSC)		(Note 2)		10		pF	
Port Nominal Sink Constant Current (P0–P9) (Global Current Register Set to 0x07)	I_{OUT}	Output register set to 0x02, $V_+ = 3.3V$, $V_{EXT} - V_{LED} = 1V$ to $2.5V$ (Note 3)	$T_A = +25^\circ C$	19.3	20	21.1	mA
				9.5	10	10.7	
			$T_A = T_{MIN}$ to $+85^\circ C$	18.8		21.8	
				9.1		11.0	
Port Logic Output Low Voltage (P0–P9)	$V_{OLP_}$	Output register set to 0x00, $I_{SINK} = 0.5mA$			0.4	V	
Port Logic Output Low Short-Circuit Current (P0–P9)		Output register set to 0x00, $V_{OLP_} = 5V$		10.8	20	mA	
Port Slew Time		From 20% current to 80% current		2		μs	
Port Sink Constant-Current Matching	ΔI_{OUT}	$T_A = +25^\circ C$, $V_+ = 3.3V$, $V_{EXT} - V_{LED} = 1.4V$, $I_{OUT} = 20mA$		± 1.5	± 4	%	
			$T_A = +25^\circ C$, $V_+ = 3.3V$, $V_{EXT} - V_{LED} = 1.4V$, $I_{OUT} = 10mA$		± 2		± 5
Output High Voltage (DOUT)	V_{OHDOUT}	$I_{SOURCE} = 6mA$	$V_+ - 0.3V$			V	
Output Low Voltage (DOUT)	V_{OLDOUT}	$I_{SINK} = 6mA$			0.3	V	

MAX6966/MAX6967

10-Port Constant-Current LED Drivers and I/O Expanders with PWM Intensity Control

TIMING CHARACTERISTICS

(Typical Operating Circuit, $V_+ = 2.25V$ to $3.6V$, $T_A = T_{MIN}$ to T_{MAX} , unless otherwise noted. Typical values are at $V_+ = 3.3V$, $T_A = +25^\circ C$.) (Note 1)

PARAMETER	SYMBOL	CONDITIONS	MIN	TYP	MAX	UNITS
Internal PWM Clock Frequency	f_{INT}		27000		45000	Hz
External PWM Clock Frequency	f_{OSC}				100	kHz
SCLK Clock Period	t_{CP}		38.4			ns
SCLK Pulse Width High	t_{CH}		19			ns
SCLK Pulse Width Low	t_{CL}		19			ns
\overline{CS} Fall to SCLK Rise Setup Time	t_{CSS}		9.5			ns
SCLK Rise to \overline{CS} Rise Hold Time	t_{CSH}		0			ns
DIN Setup Time	t_{DS}		9.5			ns
DIN Hold Time	t_{DH}		0			ns
Output Data Propagation Delay	t_{DO}				21	ns
DO _{UT} Output Rise and Fall Times	t_{FT}	$C_{LOAD} = 20pF$			10	ns
Minimum \overline{CS} Pulse High	t_{CSW}		38.4			ns
\overline{CS} Pulse Low to Not Activate CS Run	t_{CSRUN}	CS run enabled			640	μs
\overline{CS} Pulse Width to Activate CS Run	t_{CSRUN}	CS run enabled	3			ms

Note 1: All parameters tested at $T_A = +25^\circ C$. Specifications over temperature are guaranteed by design.

Note 2: Guaranteed by design.

Note 3: Port current is factory trimmed to meet a median sink current of 20mA and 10mA over all 10 ports. The ΔI_{OUT} specification guarantees current matching between ports.

MAX6966/MAX6967

10-Port Constant-Current LED Drivers and I/O Expanders with PWM Intensity Control

Typical Operating Characteristics

($T_A = +25^\circ\text{C}$, unless otherwise noted.)

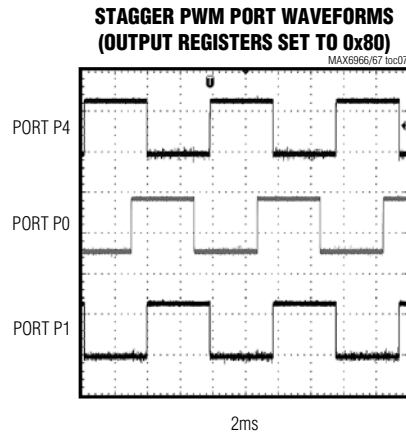
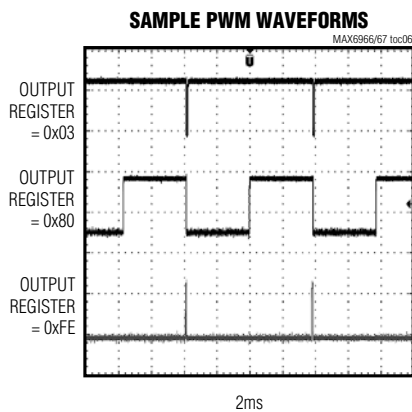
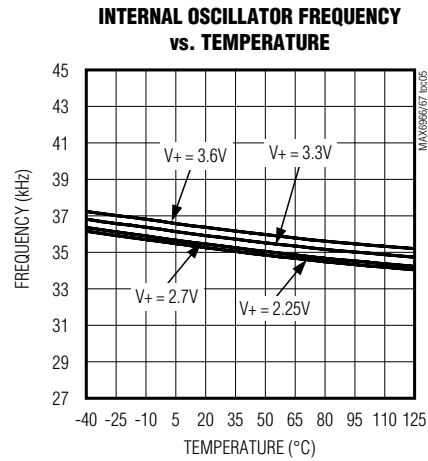
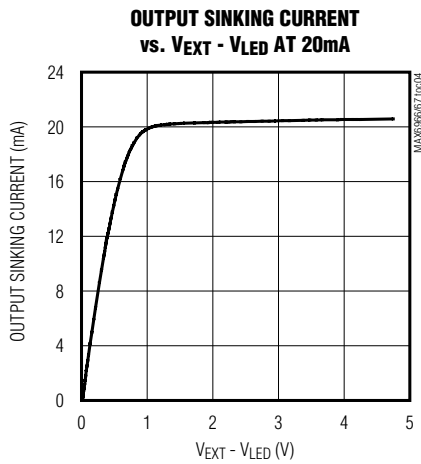
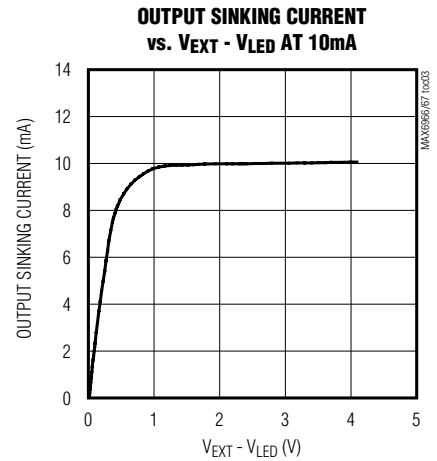
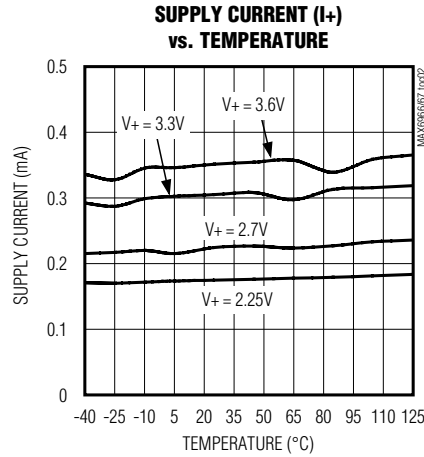
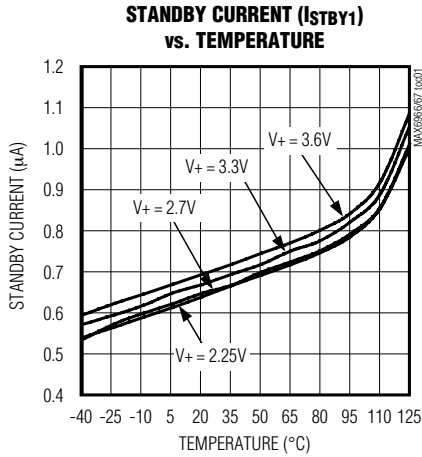

MAX6966/MAX6967

10-Port Constant-Current LED Drivers and I/O Expanders with PWM Intensity Control

Pin Description

PIN		NAME	FUNCTION
QSOP	TQFN		
1	15	SCLK	Serial-Clock Input. On SCLK's rising edge, data shifts into the internal shift register. On SCLK's falling edge, data is clocked out of DOUT. SCLK is active only while \overline{CS} is low.
2	16	\overline{CS}	Chip-Select Input. Serial data is loaded into the shift register while \overline{CS} is low. The most recent 16 bits of data latch on \overline{CS} 's rising edge.
3-7, 9-13	1-5, 7-11	P0-P9	I/O Ports. P0 to P9 can be configured as open-drain current-sink outputs rated at 20mA maximum, or as CMOS-logic inputs, or as open-drain logic outputs. Loads should be connected to a supply voltage no higher than 7V.
8	6	GND	Ground
14	12	DOUT/OSC	Serial-Data Output. The data into DIN is valid at DOUT 15.5 clock cycles later. Use this pin to daisy-chain several devices or allow data readback. Output is push-pull. OSC Input. Apply a square-wave CMOS clock up to 100kHz as alternate PWM clock source. The MAX6966 powers up with DOUT/OSC defaulting as DOUT output. The MAX6967 powers up with DOUT/OSC defaulting as OSC input.
15	13	DIN	Serial-Data Input. Data from DIN loads into the internal 16-bit shift register on SCLK's rising edge.
16	14	V+	Positive Supply Voltage. Bypass V+ to GND with a 0.1 μ F ceramic capacitor.
—	PAD	Exposed pad	Exposed Pad on Package Underside. Connect to GND.

Quick-Start Guide

This section describes how to configure a MAX6966 or MAX6967 on power-up.

Software engineers can use this section as a plain-text guide to the device's initialization routine. Hardware engineers can use this section to get a quick overview of the device's capabilities and feature tradeoffs:

- 1) **Before power-up**, all 10 I/O ports P0 to P9 are high impedance. They may be connected to inputs up to +7V or loads connected to independent rails up to +7V. The SPI bus inputs (SCLK, \overline{CS} , DIN) are not overvoltage protected, and must not be driven from a voltage higher than V+.
- 2) **After power-up**, all 10 I/O ports P0 to P9 remain high impedance. They may be connected to inputs up to +7V or loads connected to V+ or independent rails up to +7V. The ports are not configured as logic inputs even though the ports are high impedance. The device is in shutdown mode, and draws minimum supply current regardless of I/O ports connections.
- 3) **Decide whether the DOUT/OSC pin will be used as SPI data output or PWM clock input**, and choose the MAX6966 or MAX6967 accordingly. If

any ports are used as logic input, or if the application needs read-after-write validation, then DOUT/OSC needs to be configured as DOUT. Note that both the MAX6966 and MAX6967 can configure DOUT/OSC as either DOUT output or OSC clock input; the only difference is the power-up default.

- 4) **Allocate port functionality for the 10 I/O ports.** All ports have the same features, so allocate ports for either software convenience or board-routing reasons. Any port can be constant-current LED drivers (static or PWM), an open-drain logic output, or a logic input. If fewer than 10 ports are used as constant-current drivers, see the *Applications Information* section for details on how to optimize the PWM phasing to minimize load supply-current modulation.
- 5) **Decide how to implement LED intensity control.** The MAX6966/MAX6967 provide:
 - Individual 8-bit PWM control per constant-current output
 - Individual 1-bit analog control (half/full) per constant-current output
 - Global 3-bit analog control, which applies to all constant-current outputs

MAX6966/MAX6967

10-Port Constant-Current LED Drivers and I/O Expanders with PWM Intensity Control

The tradeoff for LED intensity control is between depth of current-control resolution, noise constraints, and software complexity:

- For high LED resolution where each LED needs individual intensity settings, use the 8-bit PWM control plus the 1-bit analog control to get 9 bits of individual LED intensity control.
- For absolute maximum LED resolution where the LED uses the same intensity settings, use the 8-bit PWM control plus the 1-bit analog control, plus the global 3-bit analog control to get 12 bits of LED intensity control.
- For lowest noise applications where PWM cannot be used, 1 bit of individual analog control is available. If all LEDs use the same intensity settings, the 1-bit analog control plus the global 3-bit analog control provide 4 bits of static LED intensity control.
- If the standard half/full constant-current settings of 10mA/20mA are not acceptable, then the global 3-bit analog control can be used to reduce the currents for all the constant-current outputs.

6) **Take care with PC board layout.** The MAX6966/MAX6967 are switching moderate currents in PWM applications, so the MAX6966/MAX6967 and the load supplies need careful decoupling to minimize conducted noise. Also, the serial interface is fast, so

simple overshoot-damping terminations may be required if the tracks are long.

Detailed Description

The MAX6966/MAX6967 are general-purpose input/output (GPIO) peripherals that provide 10 I/O ports, P0 to P9, controlled through a high-speed SPI-compatible serial interface. The 10 I/O ports can be used as logic inputs, open-drain logic outputs, or constant-current sinks in any combination. Ports withstand 7V independent of the MAX6966's or MAX6967's supply voltage whether used as logic inputs, logic outputs, or constant-current sinks.

Ports configured as constant-current outputs can be set to sink either a constant current of either 10mA or 20mA. The static port current may be PWM with a duty cycle ranging from 3/256 to 254/256 to reduce the average current, or remain static.

Ports configured as open-drain logic outputs have a relatively weak sink capability, which should still be adequate for normal logic-level outputs. Open-drain logic outputs typically require external pullup resistors to the appropriate positive supply to provide the logic-high reference. The weak drive means that the short-circuit current is low enough that inadvertently driving an LED from a port configured as a logic output is unlikely to damage the LED.

The MAX6966/MAX6967 are rated for all 10 outputs to carry their maximum 20mA loads at the same time. The port configuration options are shown in Table 1.

Table 1. Port Configuration Options

PORT TYPE	OUTPUT REGISTER CODE	BEHAVIOR OUT OF SHUTDOWN (CONFIGURATION REGISTER BIT D0 = 1)	BEHAVIOR IN SHUTDOWN (CONFIGURATION REGISTER BIT D0 = 0)	APPLICATION NOTES
Low-logic output	0x00	Logic-low output, not constant current		Lowest supply current unaffected by shutdown
High-logic output	0x01	Logic-high output with external pullup resistor; otherwise, high impedance		
Logic input		CMOS logic input		
Constant-current static sink output	0x02	Static constant-current sink output	High impedance	Full constant-current drive with no PWM noise
Constant-current PWM output	0x03–0xFE	PWM constant-current sink output		Adjustable constant current
LED off	0xFF	Logic-high output with external pullup resistor; otherwise, high impedance		LED off

MAX6966/MAX6967

10-Port Constant-Current LED Drivers and I/O Expanders with PWM Intensity Control

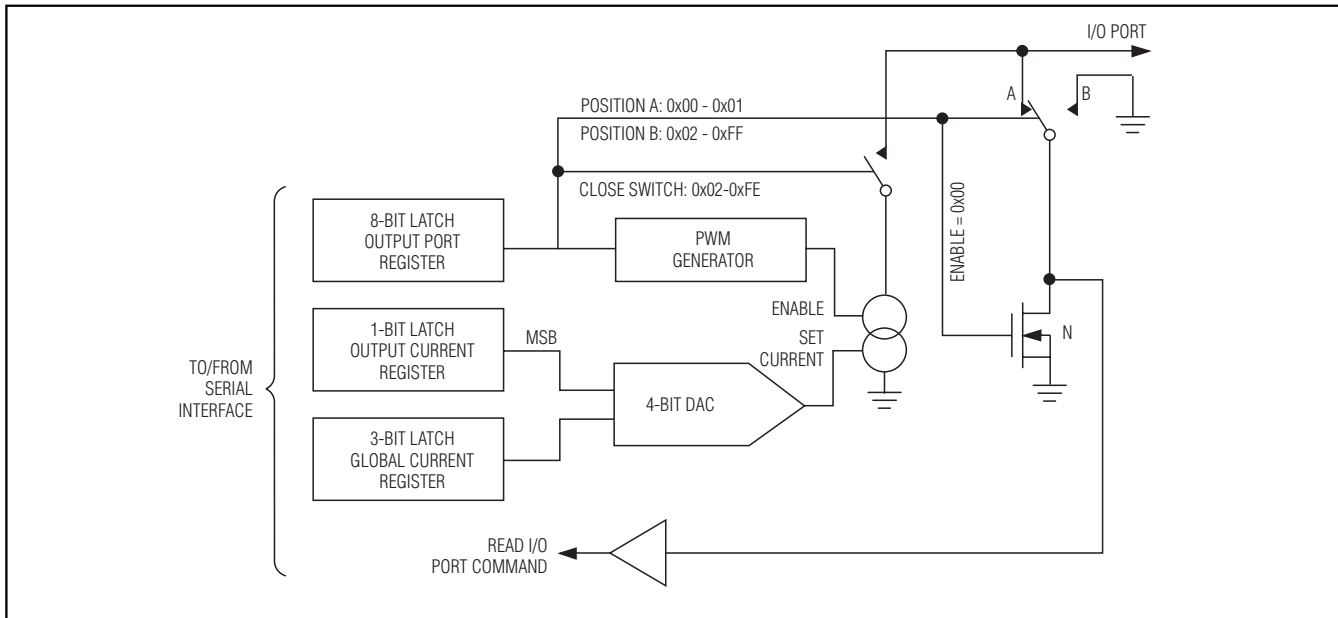

Figure 1. Simplified Schematic of I/O Ports

Figure 1 shows the I/O port structure of the MAX6966/MAX6967. I/O ports P0 to P9 default to high impedance on power-up, so LED or other port loads connected draw no current, and ports used as inputs do not load their source signals.

Standby Mode and Operating Current

When all the ports are configured as logic inputs or outputs (all output registers set to value 0x00 or 0x01) or LED off (output register set to value 0xFF), the MAX6966/MAX6967 operate at their lowest supply current, called standby mode.

When PWM intensity control is used (one or more output registers set to a value between 0x03 and 0xFE), the operating current increases because the internal PWM circuitry is running.

The operating current also increases whenever a port that is set is active low as a constant-current output (output register set to a value between 0x02 and 0xFE), even if a load is not applied to the port. This current increase is due to an internal current mirror being enabled for that port output to provide the accurate constant-current sink. There is a gated mirror for each output, and each mirror is only enabled when required. When PWM is used, a current mirror is only turned on for the output's on-time. This means that operating current varies as constant-current outputs are turned on

and off through the serial interface, as well as by the PWM intensity control.

Shutdown Mode

In shutdown mode, all ports configured as constant-current outputs (output register set to a value between 0x02 and 0xFE) are switched off, and these outputs go high impedance as if their registers were set to value 0xFF. Ports configured as logic inputs or outputs (output registers set to value 0x00 or 0x01) are unaffected (Table 1). This means that any ports used for GPIOs are still fully operational in shutdown mode, and port inputs can be read and output ports can be toggled at any time using the serial interface. The MAX6966/MAX6967 can therefore be used for a mix of logic inputs, logic outputs, and PWM LED drivers, and only the LED drivers are turned off automatically in shutdown.

The MAX6966/MAX6967 are put into shutdown mode by clearing the run bit (bit D0) in the configuration register (Table 4). Shutdown is exited by setting the run bit through the serial interface, or by using the CS run option discussed below. The MAX6966/MAX6967 can be configured and controlled in the normal way through the serial interface in shutdown mode. All registers are accessible in shutdown mode, and no register is changed by shutdown mode. When shutdown mode is exited, ports configured as constant-current outputs at that time start instantly with their current PWM values.

MAX6966/MAX6967

10-Port Constant-Current LED Drivers and I/O Expanders with PWM Intensity Control

If a port is changed from static logic low (0x00) or static logic high (0x01) to a constant-current value (0x02–0xFE) in shutdown mode, then that output is automatically turned off (logic high, or high impedance) like any other constant-current outputs that are disabled in shutdown. When shutdown mode is exited, the new constant-current output starts just like any other constant-current outputs.

If a port is changed from a constant-current value (0x02–0xFE) to static logic low (0x00) or static logic high (0x01) in shutdown mode, then that output is instantly set to that value as a GPIO output. When shutdown mode is exited, the new GPIO output is unaffected just like any other GPIO outputs.

CS Run Option

The MAX6966/MAX6967 can be configured so that a relatively long pulse on the \overline{CS} input brings the driver out of shutdown, as an alternative method to the normal method of writing the configuration register through the serial interface. When the CS run option is enabled, a minimum pulse on \overline{CS} sets the run bit in the configuration register, bringing the driver out of shutdown and activating any preconfigured ramp-up. Also, the SPI interface must be operated at a minimum data rate to ensure that a normal active-low \overline{CS} pulse during a 16-bit regular data transmission is not mistaken for a CS run command.

The CS run timing uses the PWM clock, which is either the internal nominal 32kHz oscillator or a user-provided clock fed into the dual-use DOUT/OSC pin (see the *PWM Clock* section for details on configuring the PWM clock).

The minimum pulse on \overline{CS} to trigger CS run and bring the driver out of shutdown is 256 to 257 periods of the PWM clock. For the internal oscillator, this time is $257 / 27000 = 9.52\text{ms}$. For the external PWM clock, this time is $257 / \text{OSC}$ and has a shortest possible time of 2.57ms when OSC is set to the maximum allowed 100kHz frequency.

The maximum pulse on \overline{CS} to ensure that CS run is not triggered (when enabled) is 255 periods of the PWM clock. For the internal oscillator, this time is $255 / 45000 = 5.66\text{ms}$. Since a transmission on the serial interface comprises 16 clocks with \overline{CS} low, a minimum 2.83kHz SCLK frequency ensures that CS run is not triggered. For the external PWM clock, this time is $255 / \text{OSC}$ and has a shortest time of 2.55ms when OSC is set to the maximum allowed frequency of 100kHz.

The SPI serial interface circuitry is independent of the CS run circuitry. Activity on SCLK and DIN is ignored by the CS run circuitry. A slow SPI transmission to the MAX6966/MAX6967 can therefore be used as both a valid data transmission (read or write), and as a means for exiting shutdown. The CS run action (i.e., setting the run bit in the configuration register) occurs before any coincident data transmission is processed. This means that a slow transmission containing a write command to the configuration register clearing the run bit would work, since the write command is implemented internally after the CS run action that sets the run bit.

The "slow transmission" cut-off data rate is expected to be lower than the SPI interface speed in the majority of applications. If this is not the case, the CS run option can still be used. Consider the situation when the MAX6966/MAX6967 have been put into shutdown with the CS run option enabled. The application uses the MAX6966/MAX6967 with some ports configured as logic inputs or outputs, which need to be accessed in shutdown. The SPI interface speed is slow, so any transmission brings the MAX6966/MAX6967 out of shutdown. So, how are the I/O ports accessed in shutdown? The solution is to write the configuration register disabling CS run (bit D1 = 0) and invoking shutdown (bit D0 = 0) as the first command. Now any other registers can be accessed while the MAX6966/MAX6967 remain in shutdown. Finally, write the configuration register reenabling CS run (bit D1 = 1) and invoking shutdown (bit D0 = 0) to restore the original status.

MAX6966/MAX6967

10-Port Constant-Current LED Drivers and I/O Expanders with PWM Intensity Control

Register Structure

The MAX6966/MAX6967 contain 16 internal registers, addressed as 0x00–0x09, and 0x10–0x15, which configure and control the peripheral (Table 2). Two addresses, 0x0E and 0x0F, do not store data but return the port input status when read. Four virtual addresses,

0x0A–0x0D allow more than one register to be written with the same data to simplify software. The no-op address, 0x20, causes no action when written or read, and is used as a dummy register when accessing one MAX6966/MAX6967 out of multiple cascaded devices.

Table 2. Register Address Map

REGISTER	COMMAND ADDRESS								HEX CODE
	D15	D14	D13	D12	D11	D10	D9	D8	
Port P0 output level or PWM	R/W	0	0	0	0	0	0	0	0x00
Port P1 output level or PWM	R/W	0	0	0	0	0	0	1	0x01
Port P2 output level or PWM	R/W	0	0	0	0	0	1	0	0x02
Port P3 output level or PWM	R/W	0	0	0	0	0	1	1	0x03
Port P4 output level or PWM	R/W	0	0	0	0	1	0	0	0x04
Port P5 output level or PWM	R/W	0	0	0	0	1	0	1	0x05
Port P6 output level or PWM	R/W	0	0	0	0	1	1	0	0x06
Port P7 output level or PWM	R/W	0	0	0	0	1	1	1	0x07
Port P8 output level or PWM	R/W	0	0	0	1	0	0	0	0x08
Port P9 output level or PWM	R/W	0	0	0	1	0	0	1	0x09
Write ports P0 through P9 with same output level or PWM	0	0	0	0	1	0	1	0	0x0A
Read port P0 output level or PWM	1								
Write ports P0 through P3 with same output level or PWM	0	0	0	0	1	0	1	1	0x0B
Read port P0 output level or PWM	1								
Write ports P4 through P7 with same output level or PWM	0	0	0	0	1	1	0	0	0x0C
Read port P4 output level or PWM	1								
Write ports P8 or P9 with same output level or PWM	0	0	0	0	1	1	0	1	0x0D
Read port P8 output level or PWM	1								
Read ports P7 through P0 inputs	1	0	0	0	1	1	1	0	0x0E
Read ports P9 and P8 inputs	1	0	0	0	1	1	1	1	0x0F
Configuration	R/W	0	0	1	0	0	0	0	0x10
Ramp-down	R/W	0	0	1	0	0	0	1	0x11
Ramp-up	R/W	0	0	1	0	0	1	0	0x12
Output current ISET70	R/W	0	0	1	0	0	1	1	0x13
Output current ISET98	R/W	0	0	1	0	1	0	0	0x14
Global current	R/W	0	0	1	0	1	0	1	0x15
No-op	R/W	0	1	0	0	0	0	0	0x20
Factory reserved; do not write to this register	R/W	1	1	1	1	1	0	1	0x7D

MAX6966/MAX6967

10-Port Constant-Current LED Drivers and I/O Expanders with PWM Intensity Control

Initial Power-Up

On power-up, all control registers are reset (Table 3). Power-up status sets I/O ports P0 to P9 high impedance, and puts the device into shutdown mode. This means that any LED (or other) loads are effectively turned off, and the MAX6966/MAX6967 start in its lowest power condition.

PWM Clock

An internal 32kHz oscillator generates PWM timing. If all output ports are set to static levels, the internal oscil-

lator and PWM logic are disabled automatically, and the MAX6966/MAX6967 operating current is lowest. The internal 32kHz oscillator can be replaced by a user clock up to 100kHz if a precise or synchronized PWM frequency source is desired. The clock is fed into the dual-use DOUT/OSC pin, which is switched between a port output and a clock input using the OSC bit in the configuration register (Table 4).

Table 3. Initial Power-Up Register Status

REGISTER	POWER-UP CONDITION	ADDRESS CODE (HEX)	REGISTER DATA							
			D7	D6	D5	D4	D3	D2	D1	D0
Port P0 output level or PWM	Port 0 high impedance	0x00	1	1	1	1	1	1	1	1
Port P1 output level or PWM	Port 1 high impedance	0x01	1	1	1	1	1	1	1	1
Port P2 output level or PWM	Port 2 high impedance	0x02	1	1	1	1	1	1	1	1
Port P3 output level or PWM	Port 3 high impedance	0x03	1	1	1	1	1	1	1	1
Port P4 output level or PWM	Port 4 high impedance	0x04	1	1	1	1	1	1	1	1
Port P5 output level or PWM	Port 5 high impedance	0x05	1	1	1	1	1	1	1	1
Port P6 output level or PWM	Port 6 high impedance	0x06	1	1	1	1	1	1	1	1
Port P7 output level or PWM	Port 7 high impedance	0x07	1	1	1	1	1	1	1	1
Port P8 output level or PWM	Port 8 high impedance	0x08	1	1	1	1	1	1	1	1
Port P9 output level or PWM	Port 9 high impedance	0x09	1	1	1	1	1	1	1	1
Configuration (MAX6966 only)	Shutdown mode, CS run disabled, DOUT/OSC is DOUT output	0x10	0							
Configuration (MAX6967 only)	Shutdown mode, CS run disabled, DOUT/OSC is OSC input		1	0	0	0	0	0	0	0
Ramp-down	Fade disabled	0x11	0	0	0	0	0	0	0	0
Ramp-up	—	0x12	0	0	0	0	0	0	0	0
Output current ISET70	I _{PEAK} = 10mA for ports P7–P0	0x13	0	0	0	0	0	0	0	0
Output current ISET98	I _{PEAK} = 10mA for ports P9, P8	0x14	0	0	0	0	0	0	0	0
Global current	Full current	0x15	0	0	0	0	0	1	1	1

MAX6966/MAX6967

10-Port Constant-Current LED Drivers and I/O Expanders with PWM Intensity Control

PWM Timing and Phasing

A PWM period comprises 256 cycles of the nominal 32kHz PWM clock (Figure 2). Ports can be set individually to a PWM duty between 3/256 and 254/256.

PWM timing can be configured one of two ways by the setting of the stagger bit in the configuration register (Table 4). When the stagger bit is clear, all outputs using PWM switch at the same time use the timing shown in Figure 2. All outputs therefore draw load current at exactly the same time for the same PWM setting. This means

that if, for example, all outputs are set to 128/256 duty cycle, the current draw would be zero (all loads off) for half the time and full (all loads on) for the other half.

When the stagger bit is set, the PWM timing of the 10 port outputs is staggered by 32 counts of the 256-count PWM period (i.e., 1/8), distributing the port output switching points across the PWM period (Figure 3). The staggering reduces the di/dt output-switching transient on the supply, and also reduces the peak/mean current requirement.

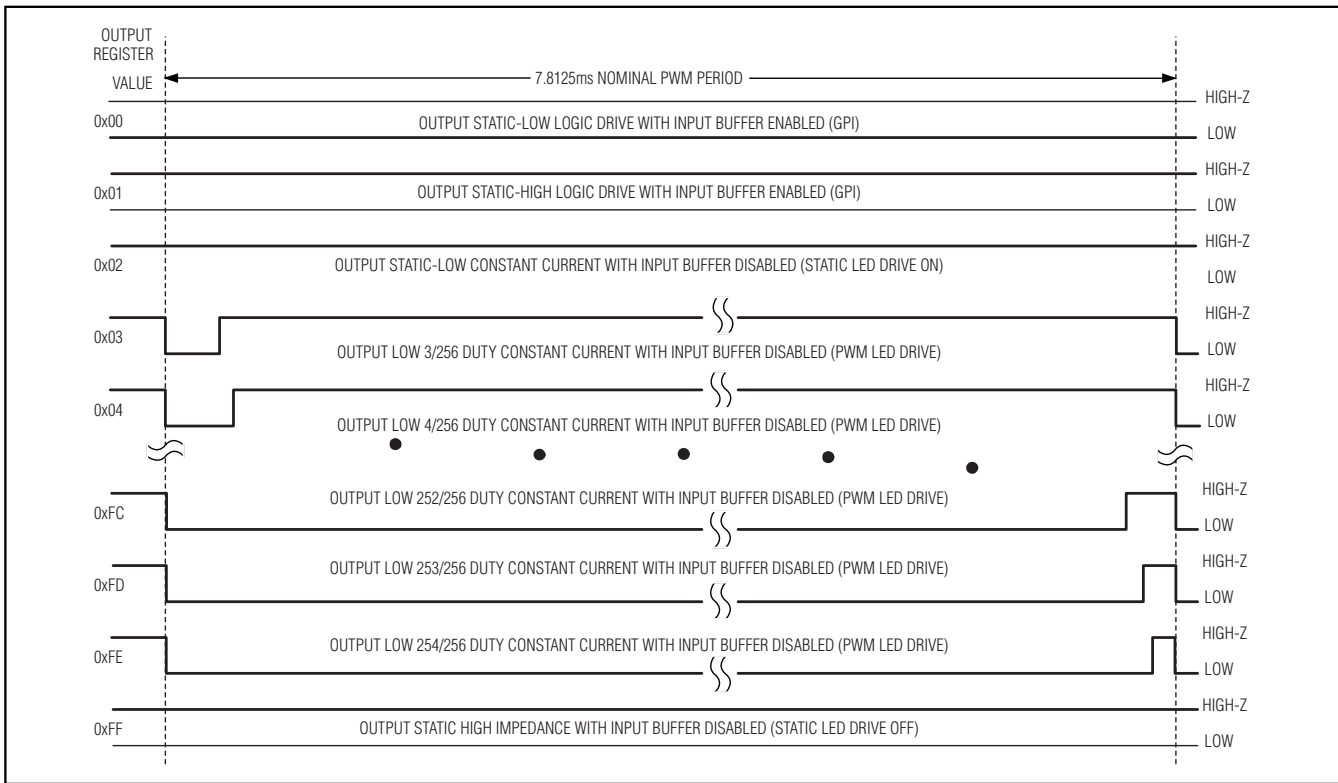

Figure 2. Static and PWM Constant-Current Waveforms

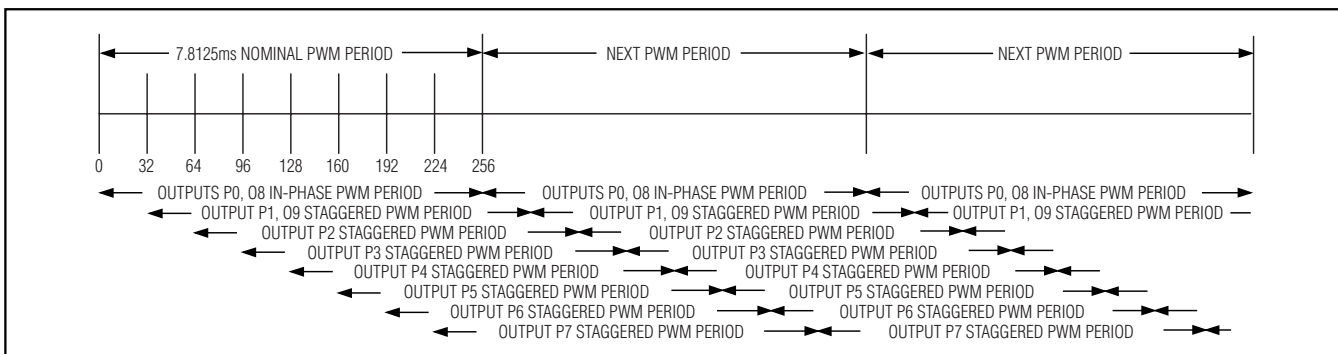

Figure 3. Staggered PWM Waveform

MAX6966/MAX6967

10-Port Constant-Current LED Drivers and I/O Expanders with PWM Intensity Control

Table 4. Configuration Register

REGISTER	R/W	ADDRESS CODE (HEX)	REGISTER DATA							
			D7	D6	D5	D4	D3	D2	D1	D0
CONFIGURATION		0x10	DOUT /OSC	X	PWM stagger	Hold-off status	Fade-off status	Ramp-up enable/status	CS run	Shutdown/run
Write device configuration	0		OSC	X	Stagger	Hold-off	Fade-off	Ramp-up enable	CS run	Run
Read-back device configuration	1							Ramp-up status		
Shutdown mode (CS run disabled) Put or keep device in shutdown, disable CS run	0		X	X	X	X	X	X	0	0
Shutdown mode (CS run enabled) Put or keep device in shutdown, enable CS run	0		X	X	X	X	X	X	1	0
Run mode (device is currently in run mode)	0		X	X	X	0*	0*	X	X	1
Run (exit shutdown) without ramp-up (device is currently in shutdown); bring device out of shutdown instantly, ignoring fade register setting	0	X	X	X	0*	0*	0	X	1	
Run (exit shutdown) with ramp-up (device is currently in shutdown); bring device out of shutdown using fade register ramp-up setting	0	X	X	X	0*	0*	1	X	1	
Run (abort shutdown sequence) (device is currently in hold-off/fade-off sequence to shutdown); bring device out of shutdown instantly, ignoring fade register setting	0	X	X	X	0*	1*	1	X	1	
					1*	0*				
					1*	1*				
Status: shutdown mode	1	X	X	Stagger	0	0	0	CS run	0	
Status: in fade-off sequence to shutdown mode	1	X	X	Stagger	0	1	0	CS run	0	
Status: in hold-off sequence to shutdown mode	1	X	X	Stagger	1	0	0	CS run	0	
Status: run mode	1	X	X	Stagger	0	0	0	CS run	1	
Status: in ramp-up sequence to run mode	1	X	X	Stagger	0	0	1	CS run	1	
PWM outputs are in phase	X	X	X	0	X	X	X	X	X	
PWM outputs stagger phase	X	X	X	1	X	X	X	X	X	
DOUT/OSC is DOUT output, PWM clock source is internal oscillator	X	0	X	X	X	X	X	X	X	
DOUT/OSC is OSC input, PWM clock source is OSC	X	1	X	X	X	X	X	X	X	

*Current read status of this bit.

MAX6966/MAX6967

10-Port Constant-Current LED Drivers and I/O Expanders with PWM Intensity Control

The stagger bit is ideally set or cleared when the MAX6966/MAX6967 are in shutdown. If not, there may be a perceived transient flicker in any PWM-controlled LEDs because the fundamental PWM timing is being changed.

Configuration Register

The configuration register is used to select PWM phasing between outputs, test fade status, enable hardware startup from shutdown, and select shutdown or run mode (Table 4).

GPIO Port Direction Configuration

The 10 I/O ports P0 through P9 can be configured to any combination of logic inputs, logic outputs, and constant-current outputs. Configure any port as a logic input by setting its output register to 0x01, which sets the port output high impedance (Table 6).

Input Ports Registers

Reading an input port register returns the logic levels at the I/O port pins for ports that have been configured as a logic input (Table 5). A port is configured as a logic input by writing 0x01 to the port's output register (Table 5). An input ports register returns logic 0 in the appropriate bit position for a port not configured as a logic input.

The input ports registers are read only. A write to an input ports register is ignored.

Output Registers and PWM Intensity Control

The MAX6966/MAX6967 use one 8-bit register to control each output port (Table 6). Each port may be configured as a logic input, open-drain logic output, or constant-current sink with programmable current and PWM duty cycle. Ports withstand 7V independent of the MAX6966's or MAX6967's supply voltage, whether used as logic inputs, logic outputs, or constant-current sinks.

Ports configured as constant-current outputs sink a constant current set by the output current registers (Table 7) and the global current registers (Table 8). This current may be PWM with a duty cycle ranging from 3/256 to 254/256 to reduce the average current, or remain static.

The 10 registers 0x00 through 0x09 control an I/O port each (Table 6). Five pseudo-register addresses, 0x0B through 0x0F, allow groups of outputs to be set to the same value with a single command by writing the same data to multiple output registers.

PWM timing for LED intensity control is generated using either the internal 32kHz oscillator, or an external clock on DOUT/OSC. The PWM clock source is selected by configuration register bit D7 (Table 4). The MAX6966 powers up configured to use the internal 32kHz oscillator by default. The MAX6967 powers up configured to use the external clock source by default.

Table 5. Input Ports Register

REGISTER	R/W	ADDRESS CODE (HEX)	REGISTER DATA							
			D7	D6	D5	D4	D3	D2	D1	D0
Read input ports P7–P0	1	0x0E	Port P7	Port P6	Port P5	Port P4	Port P3	Port P2	Port P1	Port P0
Read input ports P9–P8	1	0x0F	0	0	0	0	0	0	Port P9	Port P8

MAX6966/MAX6967

10-Port Constant-Current LED Drivers and I/O Expanders with PWM Intensity Control

Table 6. Output Registers Format

REGISTER	R/W	ADDRESS CODE (HEX)	REGISTER DATA							HEX	
			BINARY								
			D7	D6	D5	D4	D3	D2	D1		D0
PORT P0 LEVEL OR PWM	X	0x00	MSB	OUTPUT P0 LEVEL AND PWM					LSB		
Port P0 is static-low logic-level logic port with logic input buffer enabled; reading this port returns 0. Still active in shutdown.	X		0	0	0	0	0	0	0	0	0x00
Port P0 is static-high logic-level logic port (high impedance without external pullup) or logic input with logic input buffer enabled; reading this port returns 0 or 1, depending on external conditions. Still active in shutdown.	X		0	0	0	0	0	0	0	1	0x01
Port P0 is static-low constant-current sink (PWM disabled). Logic input buffer is disabled; reading this port always returns 0. High impedance in shutdown.	X		0	0	0	0	0	0	1	0	0x02
Port P0 duty cycle is 3/256 current sink. GPI logic input buffer is disabled; reading this port always returns 0. High impedance in shutdown.	X		0	0	0	0	0	0	1	1	0x03
Port P0 duty cycle is 4/256 current sink. GPI logic input buffer is disabled; reading this port always returns 0. High impedance in shutdown.	X		0	0	0	0	0	1	0	0	0x04
—	X		—	—	—	—	—	—	—	—	—
Port P0 duty cycle is 253/256 current sink. GPI logic input buffer is disabled; reading this port always returns 0. High impedance in shutdown.	X		1	1	1	1	1	1	0	1	0xFD
Port P0 duty cycle is 254/256 current sink. GPI logic input buffer is disabled; reading this port always returns 0. High impedance in shutdown.	X		1	1	1	1	1	1	1	0	0xFE
Port P0 is static high impedance (PWM disabled). GPI logic input buffer is disabled; reading this port always returns 0. High impedance in shutdown.	X		1	1	1	1	1	1	1	1	0xFF

MAX6966/MAX6967

10-Port Constant-Current LED Drivers and I/O Expanders with PWM Intensity Control

Table 6. Output Registers Format (continued)

REGISTER	R/W	ADDRESS CODE (HEX)	REGISTER DATA					HEX			
			BINARY								
			D7	D6	D5	D4	D3		D2	D1	D0
			MSB	OUTPUT P0 LEVEL AND PWM					LSB		
Port P1 level or PWM	X	0x01	MSB	Port P1 level or PWM					LSB	0x00 to 0xFF	
Port P2 level or PWM	X	0x02	MSB	Port P2 level or PWM					LSB		
Port P3 level or PWM	X	0x03	MSB	Port P3 level or PWM					LSB		
Port P4 level or PWM	X	0x04	MSB	Port P4 level or PWM					LSB		
Port P5 level or PWM	X	0x05	MSB	Port P5 level or PWM					LSB		
Port P6 level or PWM	X	0x06	MSB	Port P6 level or PWM					LSB		
Port P7 level or PWM	X	0x07	MSB	Port P7 level or PWM					LSB		
Port P8 level or PWM	X	0x08	MSB	Port P8 level or PWM					LSB		
Port P9 level or PWM	X	0x09	MSB	Port P9 level or PWM					LSB		
Writes ports P0 through P9 with same level or PWM	0	0x0A	MSB	Ports P0 through P9 level or PWM					LSB		
Reads port P0 level or PWM	1		MSB	Port P0 level or PWM					LSB		
Writes ports P0 through P3 with same level or PWM	0	0x0B	MSB	Ports P0 through P3 level or PWM					LSB		
Reads port P0 level or PWM	1		MSB	Port P0 level or PWM					LSB		
Writes ports P4 through P7 with same level or PWM	0	0x0C	MSB	Ports P4 through P7 level or PWM					LSB		
Reads port P4 level or PWM	1		MSB	Port P4 level or PWM					LSB		
Write ports P8 and P9 with same level or PWM	0	0x0D	MSB	Ports P8, P9 level, or PWM					LSB		
Reads port P8 level or PWM	1		MSB	Port P8 level or PWM					LSB		

MAX6966/MAX6967

10-Port Constant-Current LED Drivers and I/O Expanders with PWM Intensity Control

Output Current Registers

Each output port's individual constant-current sink can be set to be either half or full global current. The individual currents are set by the output current registers (Table 7). The global current is set by the global current register (Table 8).

Each output current can be set individually to best suit the maximum operating current of an LED load, or even adjusted on the fly to double the effective intensity control range of each output. When the global current register is set to maximum, the individual current selection is 10mA (half) or 20mA (full).

Table 7. Output Current Register Format

REGISTER	R/W	ADDRESS CODE (HEX)	REGISTER DATA							
			D7	D6	D5	D4	D3	D2	D1	D0
OUTPUT CURRENT IOU70	X	0x13	IOU7	IOU6	IOU5	IOU4	IOU3	IOU2	IOU1	IOU0
Output P0 is set to half constant current	X		X	X	X	X	X	X	X	0
Output P0 is set to full constant current	X		X	X	X	X	X	X	X	1
Output P1 is set to half constant current	X		X	X	X	X	X	X	0	X
Output P1 is set to full constant current	X		X	X	X	X	X	X	1	X
Output P2 is set to half constant current	X		X	X	X	X	X	0	X	X
Output P2 is set to full constant current	X		X	X	X	X	X	1	X	X
Output P3 is set to half constant current	X		X	X	X	0	X	X	X	X
Output P3 is set to full constant current	X		X	X	X	1	X	X	X	X
Output P4 is set to half constant current	X		X	X	0	X	X	X	X	X
Output P4 is set to full constant current	X		X	X	1	X	X	X	X	X
Output P5 is set to half constant current	X		X	0	X	X	X	X	X	X
Output P5 is set to full constant current	X		X	1	X	X	X	X	X	X
Output P6 is set to half constant current	X		X	0	X	X	X	X	X	X
Output P6 is set to full constant current	X		X	1	X	X	X	X	X	X
Output P7 is set to half constant current	X		0	X	X	X	X	X	X	X
Output P7 is set to full constant current	X	1	X	X	X	X	X	X	X	
OUTPUT CURRENT IOU98	0	0x14	X	X	X	X	X	X	IOU9	IOU8
	1		0	0	0	0	0	0	IOU9	IOU8
Output P8 is set to half constant current	X		X	X	X	X	X	X	X	0
Output P8 is set to full constant current	X		X	X	X	X	X	X	X	1
Output P9 is set to half constant current	X		X	X	X	X	X	X	0	X
Output P9 is set to full constant current	X		X	X	X	X	X	X	1	X

MAX6966/MAX6967

10-Port Constant-Current LED Drivers and I/O Expanders with PWM Intensity Control

Table 8. Global Current Register Format

REGISTER	R/W	ADDRESS CODE (HEX)	REGISTER DATA							
			D7	D6	D5	D4	D3	D2	D1	D0
GLOBAL CURRENT	0	0x15	X	X	X	X	X	ISET2	ISET1	ISET0
	1		0	0	0	0	0	ISET2	ISET1	ISET0
Full current is 2.5mA; half current is 1.25mA	X		X	X	X	X	0	0	0	
Full current is 5mA; half current is 2.5mA	X		X	X	X	X	0	0	1	
Full current is 7.5mA; half current is 3.75mA	X		X	X	X	X	0	1	0	
Full current is 10mA; half current is 5mA	X		X	X	X	X	0	1	1	
Full current is 12.5mA; half current is 6.25mA	X		X	X	X	X	1	0	0	
Full current is 15mA; half current is 7.5mA	X		X	X	X	X	1	0	1	
Full current is 17.5mA; half current is 8.75mA	X		X	X	X	X	1	1	0	
Full current is 20mA; half current is 10mA	X		X	X	X	X	1	1	1	

Global Current Register

The global current register sets the full (maximum) constant current sunk into an I/O port (Table 8). Each output port's individual constant-current sink can be set to be either half or full global current by the output current registers (Table 7). By default, maximum current is 20mA, so the default half current is 10mA.

Ramp-Up and Ramp-Down Controls

The MAX6966/MAX6967 provide automatic controls that allow the currents' outputs to be ramped down into automatic shutdown (ramp-down), and ramped up again out of shutdown (ramp-up) without further interaction (Figures 4 and 5). Ramp-down comprises a programmable hold-off delay, which also maintains the outputs at full current for a time before the programmed

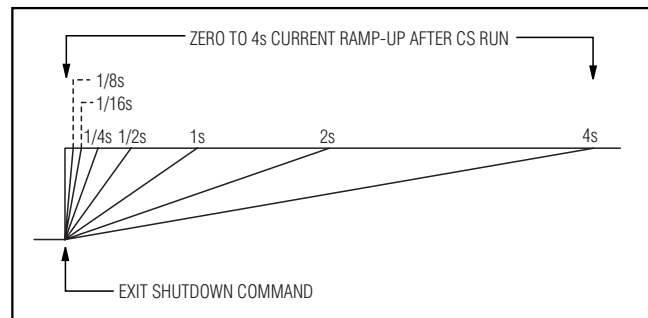

Figure 4. Ramp-Up Behavior

fade-off time, during which the currents' outputs are ramped down.

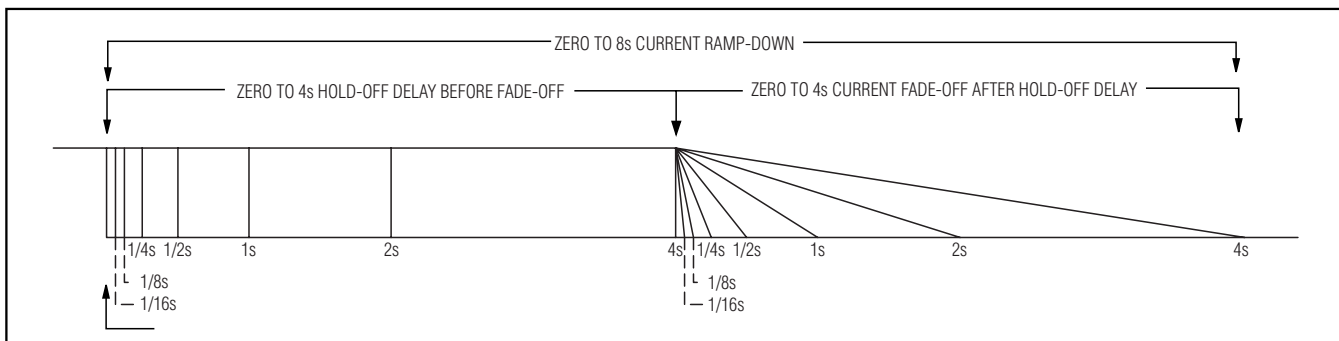

Figure 5. Ramp-Down, Hold-Off, and Fade-Off Behavior

MAX6966/MAX6967

10-Port Constant-Current LED Drivers and I/O Expanders with PWM Intensity Control

The ramp-down register sets the hold-off and fade-off times and allows hold-off and fade-off to be disabled (zero delay), if desired (Table 9). The ramp-up register sets the ramp-up time and allows ramp-up to be disabled (zero delay), if desired (Table 10). The configuration register contains 3 status bits that identify whether the MAX6966/MAX6967 are in hold-off, fade-off, or ramp-up condition (Table 4). The configuration register also enables or disables ramp-up. One write to the configuration register can put the MAX6966/MAX6967 into shutdown (using hold-off and fade-off settings in the fade

register) and determine whether CS run is enabled for restart, and whether ramp-up is to be used for restart.

Table 9. Ramp-Down Register Format

REGISTER	R/W	ADDRESS CODE (HEX)	REGISTER DATA							
			D7	D6	D5	D4	D3	D2	D1	D0
Write ramp-down	0	0x11	X	X	Hold-off			Fade-off		
Read ramp-down	1		0	0						
Fade-off time (f_{PWM} = 32768Hz)										
Instant going into shutdown after hold-off delay	X		X	X	X	X	0	0	0	
1/16s ramp-down from full current before shutdown after hold-off delay	X		X	X	X	X	0	0	1	
1/8s ramp-down from full current before shutdown after hold-off delay	X		X	X	X	X	0	1	0	
1/4s ramp-down from full current before shutdown after hold-off delay	X		X	X	X	X	0	1	1	
1/2s ramp-down from full current before shutdown after hold-off delay	X		X	X	X	X	1	0	0	
1s ramp-down from full current before shutdown after hold-off delay	X		X	X	X	X	1	0	1	
2s ramp-down from full current before shutdown after hold-off delay	X		X	X	X	X	1	1	0	
4s ramp-down from full current before shutdown after hold-off delay	X		X	X	X	X	1	1	1	
Hold-off time (f_{PWM} = 32768Hz)										
Zero hold-off delay before fade-off going into shutdown	X		X	X	0	0	0	X	X	X
1/16s hold-off delay before fade-off going into shutdown	X		X	X	0	0	1	X	X	X
1/8s hold-off delay before fade-off going into shutdown	X		X	X	0	1	0	X	X	X
1/4s hold-off delay before fade-off going into shutdown	X		X	X	0	1	1	X	X	X
1/2s hold-off delay before fade-off going into shutdown	X		X	X	1	0	0	X	X	X
1s hold-off delay before fade-off going into shutdown	X		X	X	1	0	1	X	X	X
2s hold-off delay before fade-off going into shutdown	X		X	X	1	1	0	X	X	X
4s hold-off delay before fade-off going into shutdown	X		X	X	1	1	1	X	X	X

MAX6966/MAX6967

10-Port Constant-Current LED Drivers and I/O Expanders with PWM Intensity Control

Table 10. Ramp-Up Register Format

REGISTER	R/W	ADDRESS CODE (HEX)	REGISTER DATA							
			D7	D6	D5	D4	D3	D2	D1	D0
Write ramp-up	0	0x12	X	X	X	X	X	Ramp-up		
Read ramp-up	1		0	0	0	0	0	Ramp-up		
Ramp-up time (f _{PWM} = 32768Hz)										
Instant full current coming out from shutdown	X		X	X	X	X	0	0	0	
1/16s ramp-up to full current coming out from shutdown	X		X	X	X	X	0	0	1	
1/8s ramp-up to full current coming out from shutdown	X		X	X	X	X	0	1	0	
1/4s ramp-up to full current coming out from shutdown	X		X	X	X	X	0	1	1	
1/2s ramp-up to full current coming out from shutdown	X		X	X	X	X	1	0	0	
1s ramp-up to full current coming out from shutdown	X		X	X	X	X	1	0	1	
2s ramp-up to full current coming out from shutdown	X		X	X	X	X	1	1	0	
4s ramp-up to full current coming out from shutdown	X		X	X	X	X	1	1	1	

Ramp-up and ramp-down use the PWM clock for timing. If the external oscillator is selected, then this clock should be provided until the end of the sequence. If the internal oscillator is selected, it always runs during a fade sequence, even if none of the ports are using PWM.

The ramp-up and ramp-down circuit operates a 3-bit DAC. The DAC adjusts the internal current reference used to set the constant-current outputs in a similar manner to the global current register (Table 8). Because it is the master current reference that is scaled, all output constant-current and PWM settings

are adjusted at the same ratio with respect to each other. This means that LEDs are always faded at the same rate even if their different intensity settings are totally different. Figure 6 shows output fade DAC.

The maximum port output current set by the global current register (Table 8) also sets the point during ramp-down that the current starts falling, and the point during ramp-up that the current stops rising. Figure 7 shows the ramp waveforms that occur with different global current register settings.

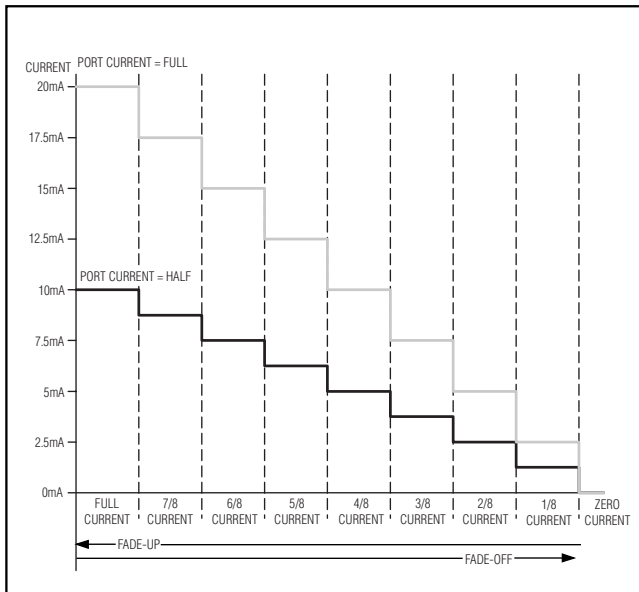

Figure 6. Output Fade DAC (Global Current = 0x07)

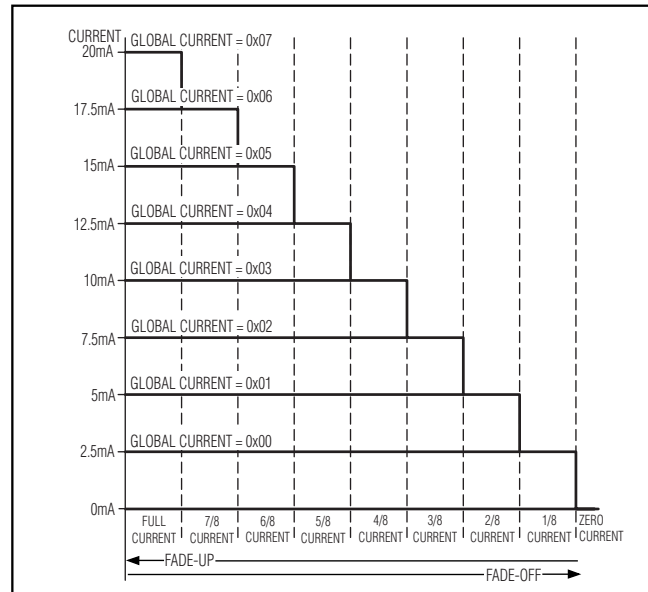

Figure 7. Global Current Modifies Fade Behavior

MAX6966/MAX6967

10-Port Constant-Current LED Drivers and I/O Expanders with PWM Intensity Control

Serial Interface

The MAX6966/MAX6967 communicate through an SPI-compatible 4-wire serial interface. The interface has three inputs: clock (SCLK), chip select (\overline{CS}), and data in (DIN), and one output, data out (DOUT). \overline{CS} must be low to clock data into or out of the device, and DIN must be stable when sampled on the rising edge of SCLK. DOUT is stable on the rising edge of SCLK.

Note that the SPI protocol expects DOUT to be high impedance when the MAX6966/MAX6967 are not being accessed; DOUT on the MAX6966/MAX6967 is never high impedance. Go to www.maxim-ic.com/an1879 for ways to convert the MAX6966/MAX6967 to tri-state, if required.

SCLK and DIN can be used to transmit data to other peripherals. The MAX6966/MAX6967 ignore all activity on SCLK and DIN except when \overline{CS} is low.

Control and Operation Using the 4-Wire Interface

Controlling the MAX6966/MAX6967 requires sending a 16-bit word. The first byte, D15 through D8, is the command, and the second byte, D7 through D0, is the data byte (Table 11).

Connecting Multiple MAX6966/MAX6967s to the 4-Wire Bus

Multiple MAX6966/MAX6967s can be interfaced to a common SPI bus by connecting DIN inputs together, connecting SCLK inputs together, and providing an individual \overline{CS} per MAX6966/MAX6967 device (Figure 8). This connection works regardless of the configuration of DOUT/OSC, but does not allow the MAX6966/MAX6967s to be read.

Table 11. Serial-Data Format

D15	D14	D13	D12	D11	D10	D9	D8	D7	D6	D5	D4	D3	D2	D1	D0
R/W	MSB	ADDRESS					LSB	MSB	DATA						LSB

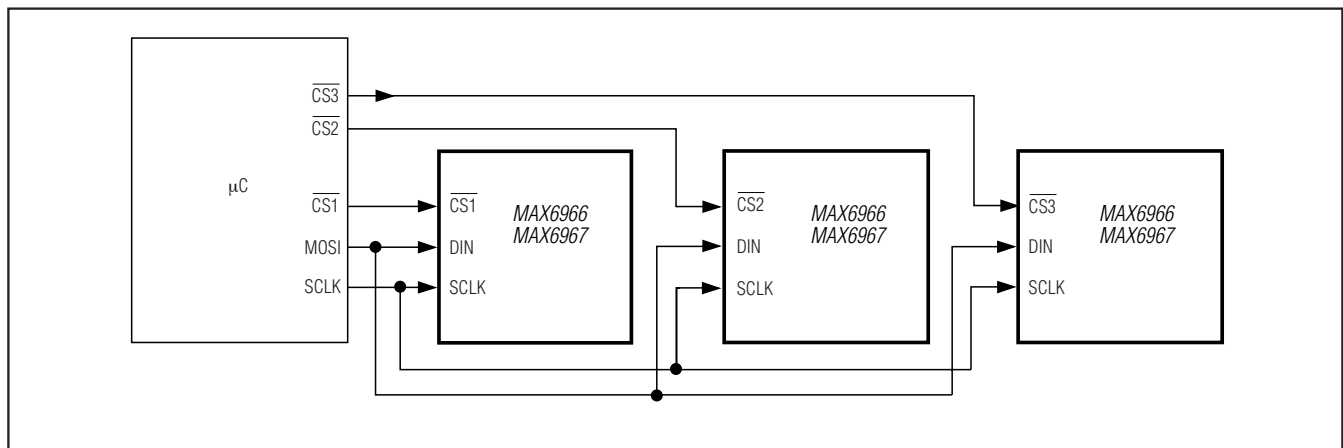

Figure 8. MAX6966/MAX6967 Multiple \overline{CS} Connection

MAX6966/MAX6967

10-Port Constant-Current LED Drivers and I/O Expanders with PWM Intensity Control

Alternatively, the MAX6966/MAX6967s can be daisy-chained by connecting the DOUT of one device to the DIN of the next, and driving SCLK and \overline{CS} lines in parallel (Figure 9). This connection allows the MAX6966/MAX6967s to be read. Data at DIN propagates through the internal shift registers and appears at DOUT 15.5 clock cycles later, clocked out on the falling edge of SCLK. When sending commands to daisy-chained MAX6966/MAX6967s, all devices are accessed at the same time. An access requires $(16 \times n)$ clock cycles, where n is the number of MAX6966/MAX6967s connect-

ed together. For daisy-chaining to work, DOUT/OSC must be configured as DOUT by clearing configuration register bit D7 to zero (Table 4). Note that the MAX6966 powers up with DOUT/OSC configured as DOUT output by default, while the MAX6967 powers up with DOUT/OSC configured as OSC input by default. The serial-interface speed (maximum SCLK) is limited to 17.5MHz when multiple devices are daisy-chained due to the DOUT propagation delay and DIN setup time. Figure 10 is the timing diagram.

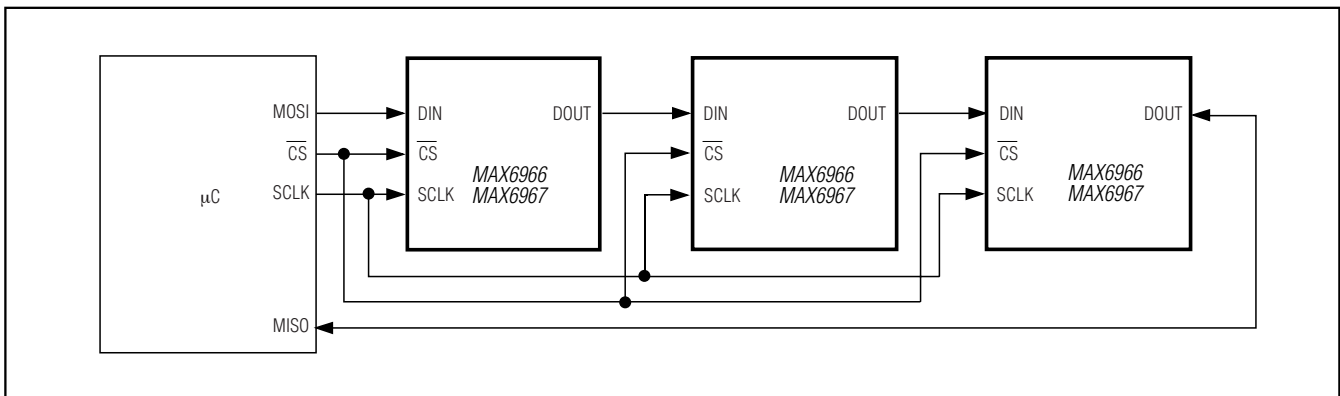

Figure 9. MAX6966/MAX6967 Daisy-Chain Connection

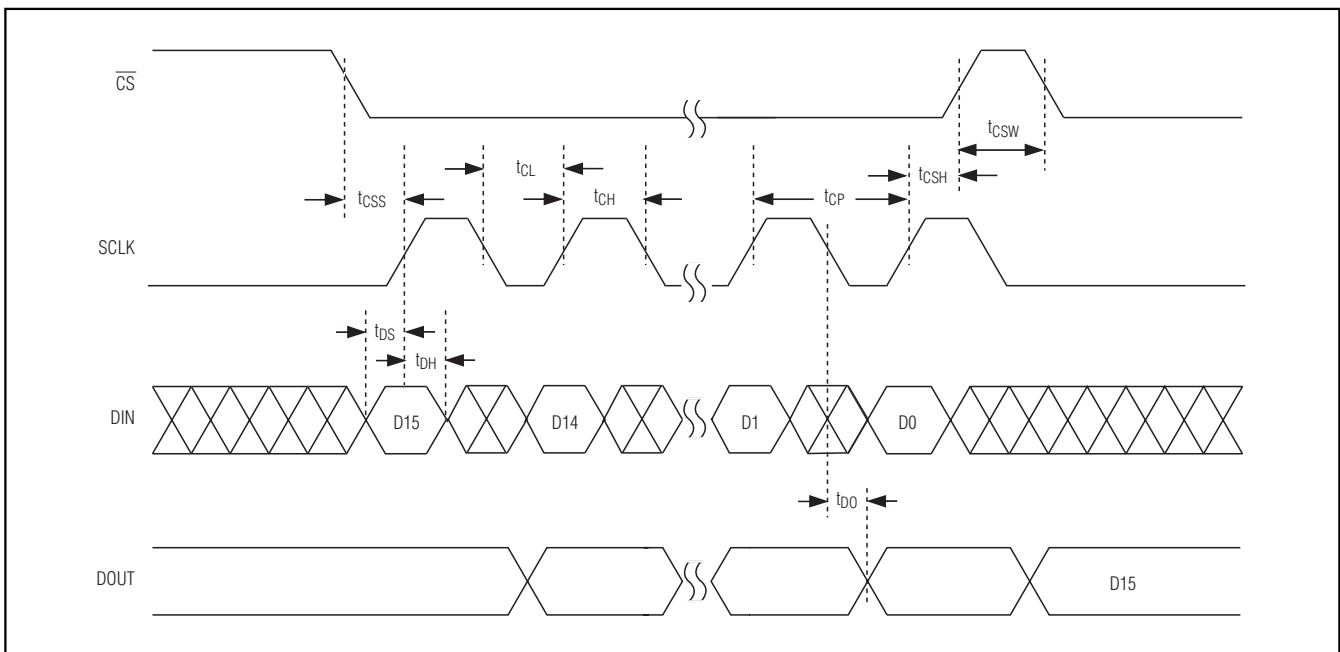

Figure 10. Timing Diagram

MAX6966/MAX6967

10-Port Constant-Current LED Drivers and I/O Expanders with PWM Intensity Control

The MAX6966/MAX6967 are written to using the following sequence (Figure 11):

- 1) Take SCLK low.
- 2) Take \overline{CS} low. This enables the internal 16-bit shift register.
- 3) Clock 16 bits of data into DIN, D15 first to D0 last, observing the setup and hold times. Bit D15 is low, indicating a write command.
- 4) Take \overline{CS} high (either while SCLK is still high after clocking in the last data bit, or after taking SCLK low).
- 5) Take SCLK low (if not already low).

If fewer or greater than 16 bits are clocked into the MAX6966/MAX6967 between taking \overline{CS} low and taking \overline{CS} high again, the MAX6966/MAX6967 store the last 16 bits received, including the previous transmission(s). The general case is when n bits (where $n > 16$) are transmitted to the MAX6966/MAX6967. The last bits comprising bits $\{n-15\}$ to $\{n\}$, are retained, and are parallel loaded into the 16-bit latch as bits D15 to D0, respectively (Figure 12).

Reading Device Registers

Any register data within the MAX6966/MAX6967 can be read by sending a logic high to bit D15. The sequence is:

- 1) Take SCLK low.
- 2) Take \overline{CS} low. This enables the internal 16-bit shift register.
- 3) Clock 16 bits of data into DIN, D15 first to D0 last. D15 is high, indicating a read command and bits D14 through D8 contain the address of the register to read. Bits D7 to D0 contain dummy data, which is discarded.
- 4) Take \overline{CS} high (either while SCLK is still high after clocking in the last data bit, or after taking SCLK low). Positions D7 through D0 in the shift register are now loaded with the register data addressed by bits D15 through D8.
- 5) Take SCLK low (if not already low).
- 6) Issue another read or write command, and examine the bit stream at DOUT; the second 8 bits are the contents of the register addressed by bits D14 through D8 in step 3).

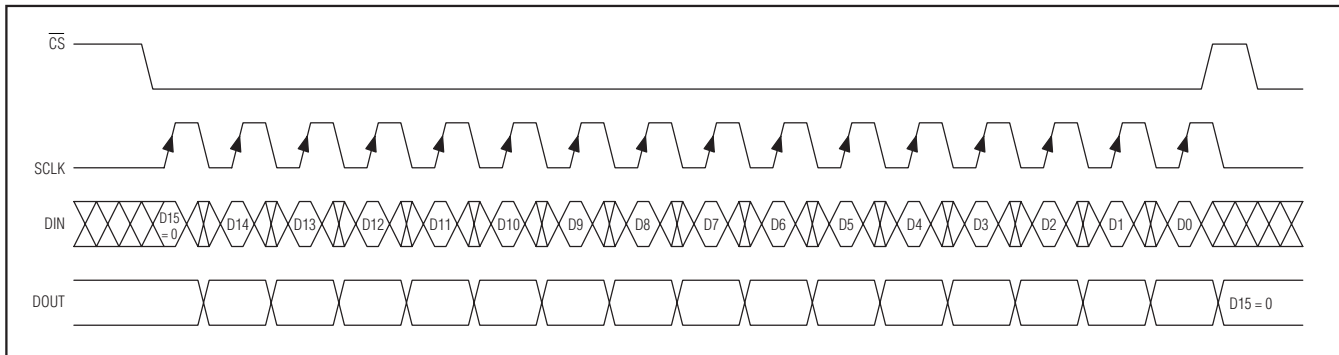

Figure 11. 16-Bit Write Transmission to the MAX6966/MAX6967

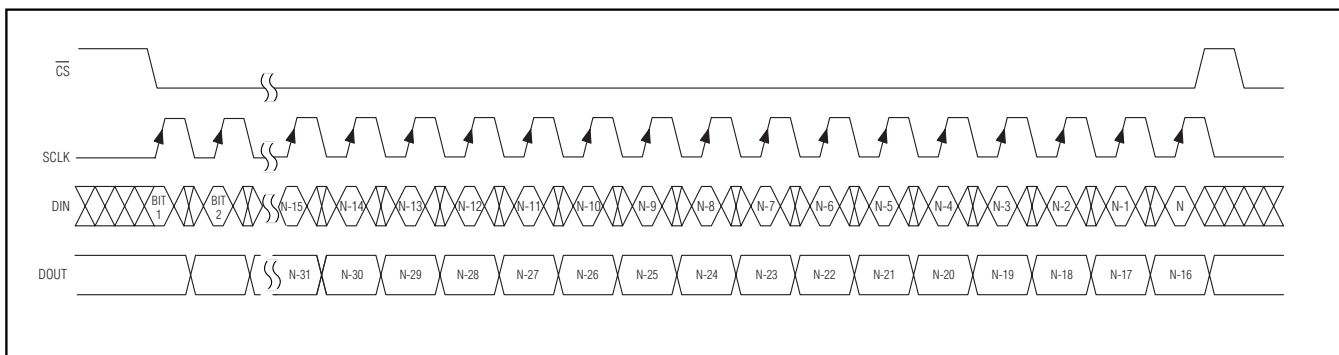

Figure 12. Transmission of More than 16 Bits to the MAX6966/MAX6967

MAX6966/MAX6967

10-Port Constant-Current LED Drivers and I/O Expanders with PWM Intensity Control

Applications Information

Hot Insertion

The I/O ports P0–P9 remain high impedance with up to 8V asserted on them when the MAX6966/MAX6967 are powered down ($V_+ = 0V$). The MAX6966/MAX6967 can therefore be used in hot-swap applications.

SPI Routing Considerations

The MAX6966/MAX6967s' SPI interface is guaranteed to operate at 26Mbps on a 2.5V supply, and on a 3.3V supply typically operate at 35Mbps. This means that transmission-line issues should be considered when the interface connections are longer than 100mm, particularly with higher supply voltages. Avoid running long adjacent tracks for SCLK, DIN, and \overline{CS} without interleaving GND traces; otherwise, the signals may cross-couple, giving false clock or chip-select transitions. Ringing may manifest itself as communication issues, often intermittent, typically due to double clocking due to ringing at the SCLK input. Fit a 1k Ω to 10k Ω parallel termination resistor to either GND or V_+ at the DIN, SCLK, and \overline{CS} inputs to damp ringing for moderately long interface runs. Use line-impedance matching terminations when making connections between boards.

Differences Between the MAX6966 and MAX6967

The MAX6966 powers up with DOUT/OSC configured as DOUT output by default. The MAX6967 powers up with DOUT/OSC configured as OSC input by default. Both parts allow the DOUT/OSC pin function to be changed through the configuration register (Table 4). If any port is used as a logic input, then configure DOUT/OSC as DOUT to allow the MAX6966/MAX6967 to be read.

In most applications, the software can be written so that either MAX6966 or MAX6967 can be fitted, and DOUT/OSC is configured appropriately on power-up. If DOUT/OSC is used as OSC, fit a series resistor between the PWM clock source and DOUT/OSC pin. A resistor value of 2.2k Ω is recommended as a starting point, but other values may be more suitable depending on the serial-interface speed and clock-source drive capability. This limits the loading on the PWM clock source on power-up when a MAX6966 is fitted, because DOUT/OSC initializes as an output. If DOUT/OSC is used as DOUT, remember that a MAX6967 cannot be read after power-up until DOUT/OSC has been reconfigured from OSC to DOUT.

Driving LEDs into Brownout

The MAX6966/MAX6967 correctly regulate the constant-current outputs, provided there is a minimum voltage drop across the port output. This port output voltage is the difference between the load (typically LED) supply and the load voltage drop (LED forward voltage). If the LED supply drops so that the minimum port output voltage is not maintained, the driver output stages brownout and the load current falls. The minimum port voltage is approximately 0.5V at 10mA sink current, and approximately 1V at 20mA sink current.

In battery applications, it may be important to operate the LEDs directly from a battery supply. For example, the LED supply voltage could be a single rechargeable Li+ battery with a maximum terminal voltage of 4.2V on charge, 3.4V to 3.7V most of the time, and down to 3V when discharged. In this scenario, the LED supply falls significantly below the brownout point when the battery is at end-of-life voltage.

MAX6966/MAX6967

10-Port Constant-Current LED Drivers and I/O Expanders with PWM Intensity Control

Figure 13 shows the typical current sunk by a LITEON LTST-C170TBKT 3.0V blue LED as the LED supply voltage is varied from 2.5V to 7V. The LED currents shown are for ports programmed for 10mA and 20mA constant current, swept over a 2.5V to 7V LED supply voltage range. It can be seen that the LED forward voltage falls with current, allowing the LED current to fall gracefully, not abruptly, in brownout. In practice, the LED current drops to 6mA to 7mA at a 3V LED supply voltage, which is an acceptable performance at end-of-life in many backlight applications.

Output Level Translation

The open-drain output architecture allows the ports to level translate the outputs to higher or lower voltages than the MAX6966/MAX6967 supply. An external pullup resistor can be used on any output to convert the high-impedance logic-high condition to a positive voltage level. The resistor can be connected to any voltage up to 7V. When using a pullup on a constant-current output, select the resistor value to sink no more than a few hundred μA in logic-low condition. This ensures that the current sink output saturates close to GND. For interfacing CMOS inputs, a pullup resistor value of 220k Ω is a good starting point. Use a lower resistance to improve noise immunity in applications where power consumption is less critical, or where a faster rise time is needed for a given capacitive load.

Using Stagger with Fewer Ports

The stagger option, when selected, applies to all ports configured as constant-current outputs. The 10 ports' PWM cycles are separated to eight evenly spaced start positions (Figure 3). This phasing can be optimized if fewer than 10 ports are used as constant-current outputs by allocating the ports with the most appropriate start positions. If eight constant-current outputs are needed, choose P0–P7 because these all have different PWM start positions. If four constant-current outputs are needed, choose P0, P2, P4, P6 or P1, P3, P5, P7 because the PWM start positions are evenly spaced. In general, choose the ports that spread the PWM start positions as evenly as possible. This optimally spreads out the current demand from the ports' load supply.

Generating a Shutdown/Run Output

An I/O port can be used to automatically generate a shutdown/run output from the MAX6966/MAX6967. The shutdown/run output is active low when the MAX6966/MAX6967 are in run mode, hold-off, fade-off, or ramp-up, and go high automatically when the MAX6966/MAX6967 finally enter shutdown after fade-off. Program the port's output register to value 0x00, which puts the output into static constant-current mode (Table 6). Program the port's output current register to half current (Table 7) to minimize operating current. Fit a 220k Ω pullup resistor to this port.

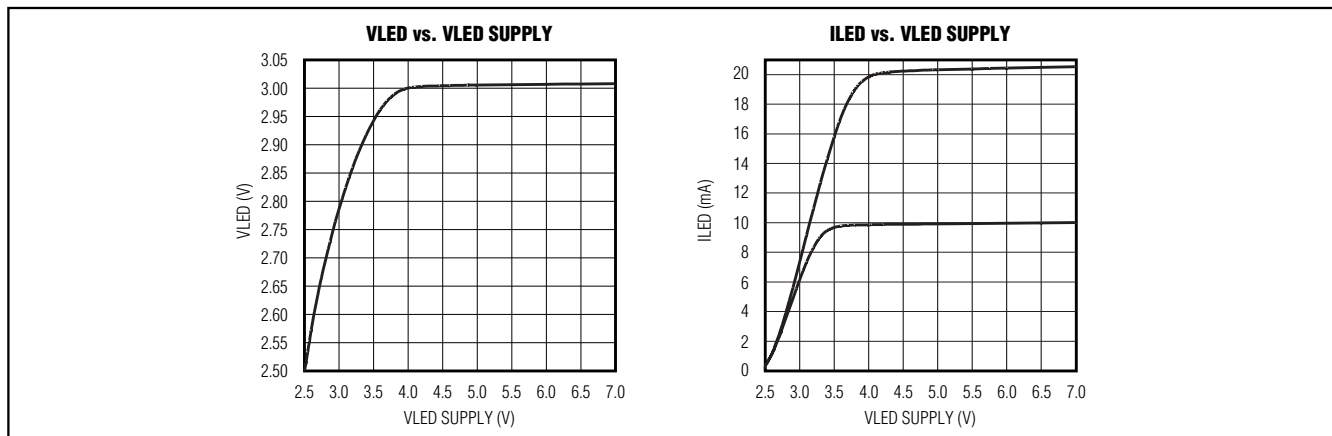

Figure 13. LED Brownout

MAX6966/MAX6967

10-Port Constant-Current LED Drivers and I/O Expanders with PWM Intensity Control

In run mode, the output port goes low, approaching 0V, as the port's static constant current saturates trying to sink a higher current than the 220kΩ pullup resistor can source.

In shutdown mode, the output goes high impedance together with any other constant-current outputs. This output remains low during ramp-up and fade-down sequences because the current drawn by the 220kΩ pullup resistor is much smaller than the available output constant current, even at the lowest fade current step.

Driving Load Currents Higher than 20mA

The MAX6966/MAX6967 can be used to drive loads needing more than 20mA, like high-current white LEDs, by paralleling outputs. For example, consider a white LED that needs to be driven with 70mA. This LED can

be driven using ports P0, P1, P2, and P3 connected in parallel (shorted together). Three of the ports should be configured for full current (20mA), and the last port should be configured for half current (10mA) to meet the 70mA requirement. The four ports can be controlled simultaneously with one write access using register 0x0B (Table 6). Note that because the output ports have current limiting, they do not have to be switched simultaneously to ensure safe current sharing.

Power-Supply Considerations

The MAX6966/MAX6967 operate with a power-supply voltage of 2.25V to 3.6V. Bypass the power supply to GND with a 0.1μF ceramic capacitor as close to the device as possible. For the TQFN version, connect the underside exposed pad to GND.

Typical Application Circuit

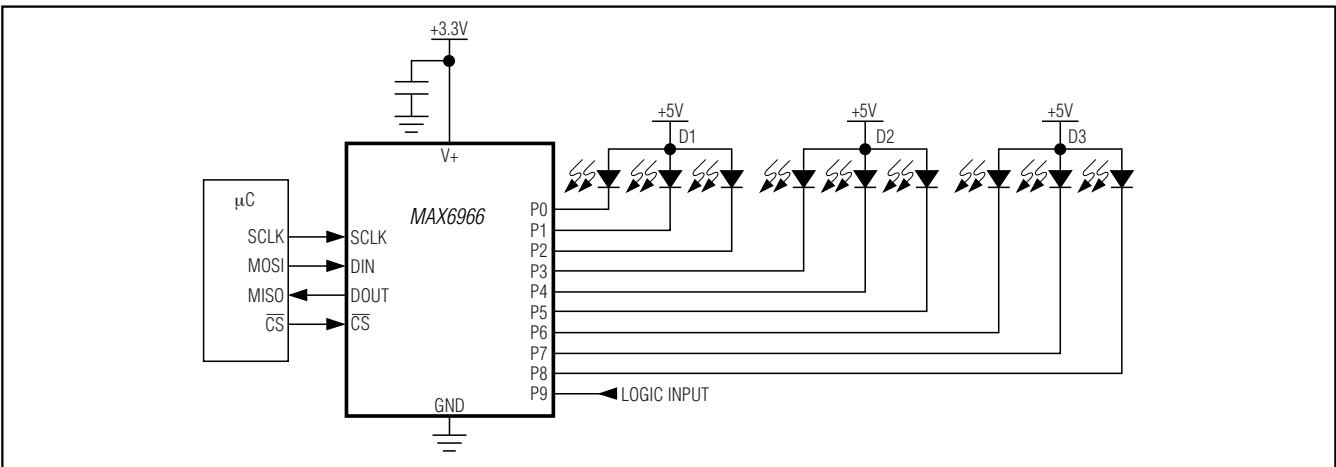

Pin Configurations

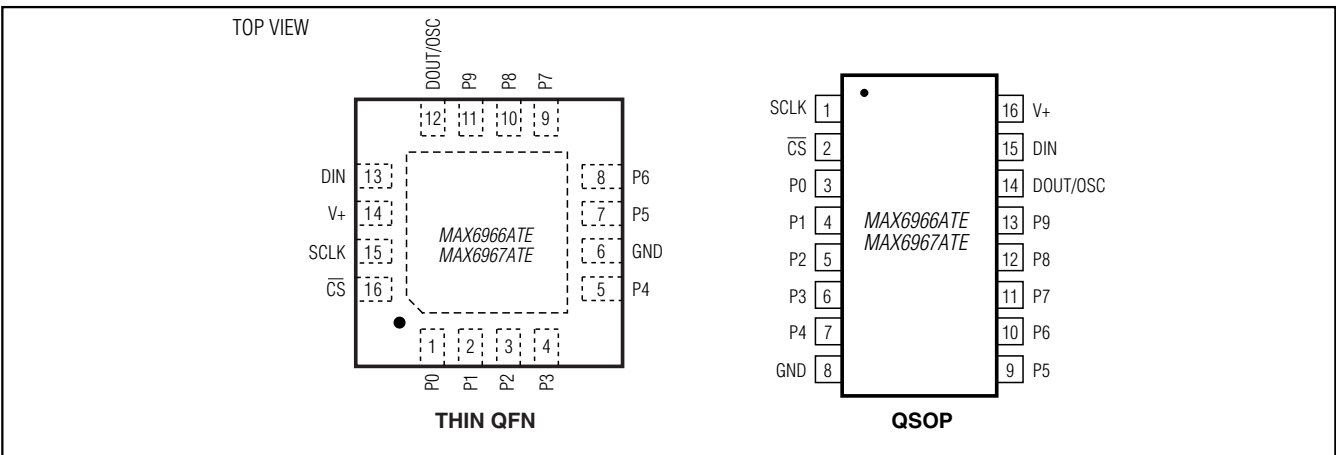

MAX6966/MAX6967

10-Port Constant-Current LED Drivers and I/O Expanders with PWM Intensity Control

Block Diagram

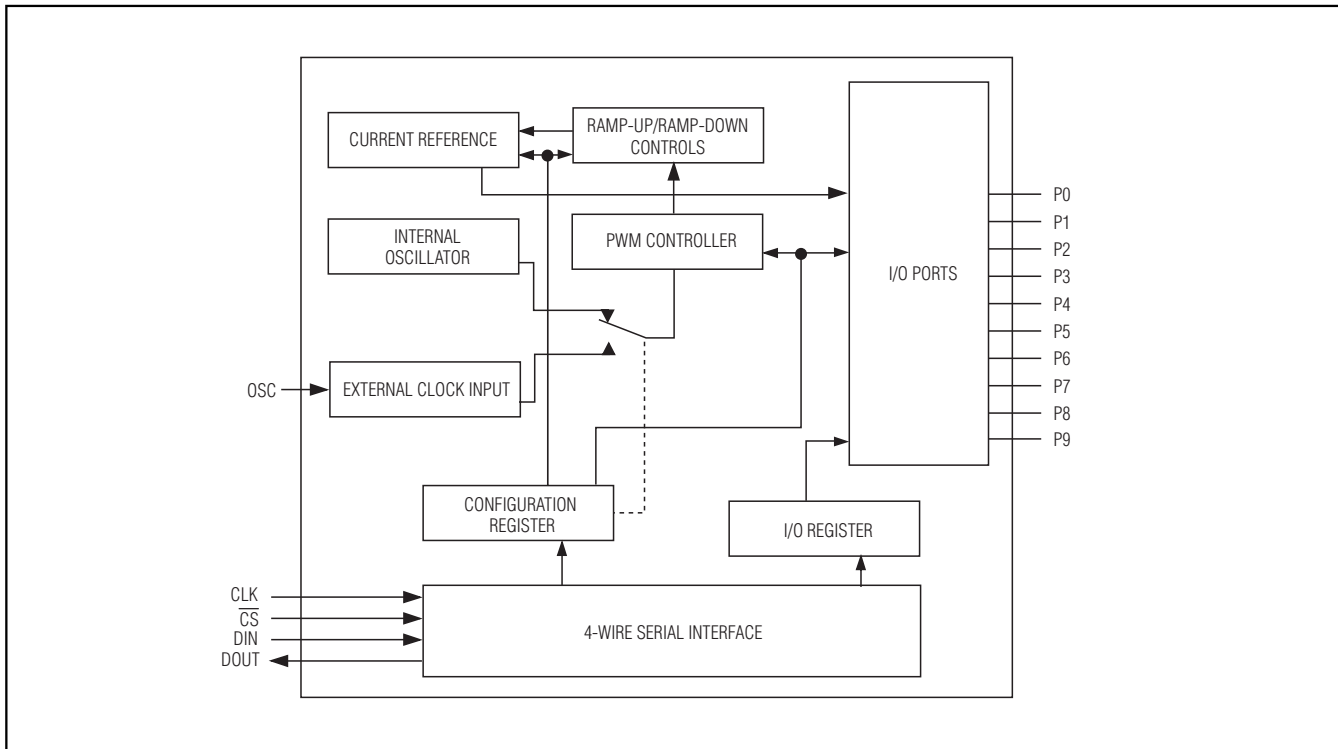

Chip Information

TRANSISTOR COUNT: 14,865

PROCESS: BiCMOS

MAX6966/MAX6967

10-Port Constant-Current LED Drivers and I/O Expanders with PWM Intensity Control

Package Information

(The package drawing(s) in this data sheet may not reflect the most current specifications. For the latest package outline information, go to www.maxim-ic.com/packages.)

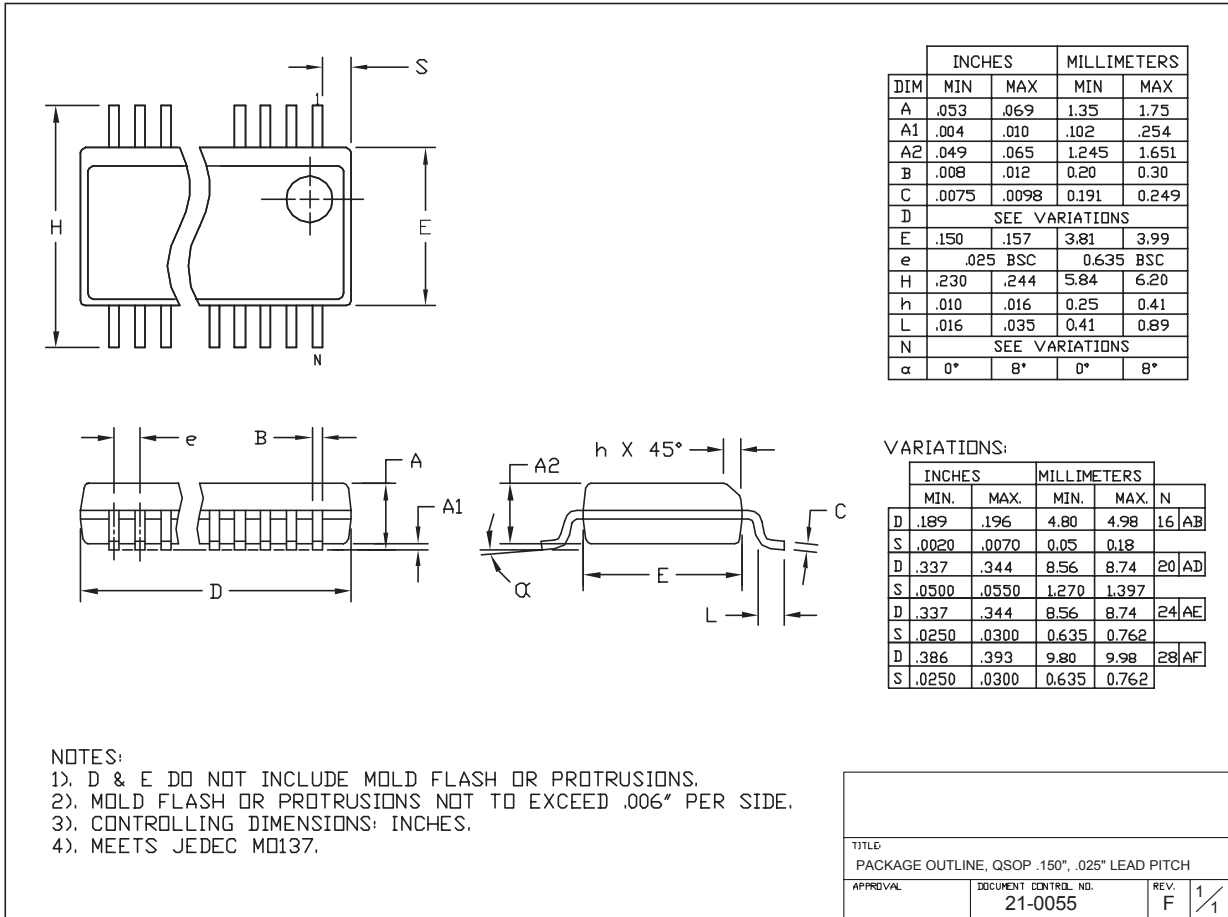

QSOP-EPS

Looking for pricing, stock, or lifecycle information?

Click below to explore more details on WIN SOURCE:

 [View MAX6966AEE+ on WIN SOURCE](#)

 [Maxim Integrated](#) Information

Optimize Your Supply Chain with WIN SOURCE Solutions

-  Global Sourcing Solution
-  Obsolete Management
-  Cost Control Management
-  Shortage Management
-  Alternative Solution
-  Excess Inventory Management