



**THE DATASHEET OF
MAX6734KATZD3+T**



MAX6730–MAX6735

Single/Dual/Triple-Voltage μ P Supervisory Circuits with Independent Watchdog Output

General Description

The MAX6730–MAX6735 single/dual/triple-voltage micro-processor (μ P) supervisors feature a watchdog timer and manual reset capability. The MAX6730–MAX6735 offer factory-set reset thresholds for monitoring voltages from +0.9V to +5V and an adjustable reset input for monitoring voltages down to +0.63V. The combination of these features significantly improves system reliability and accuracy when compared to separate ICs or discrete components.

The active-low reset output asserts and remains asserted for the reset timeout period after all the monitored voltages exceed their respective thresholds. Multiple factory-set reset threshold combinations reduce the number of external components required. The MAX6730/MAX6731 monitor a single fixed voltage, the MAX6732/MAX6733 monitor two fixed voltages, and the MAX6734/MAX6735 monitor two fixed voltages and one adjustable voltage. All devices are offered with six minimum reset timeout periods ranging from 1.1ms to 1120ms.

The MAX6730–MAX6735 feature a watchdog timer with an independent watchdog output. The watchdog timer prevents system lockup during code execution errors. A watchdog startup delay of 54s after reset asserts allows system initialization during power-up. The watchdog operates in normal mode with a 1.68s delay after initialization. The MAX6730/MAX6732/MAX6734 provide an active-low, open-drain watchdog output. The MAX6731/MAX6733/MAX6735 provide an active-low, push-pull watchdog output.

Other features include a manual reset input (MAX6730/MAX6731/MAX6734/MAX6735) and push-pull reset output (MAX6731/MAX6733/MAX6735) or open-drain reset output (MAX6730/MAX6732/MAX6734). The MAX6730–MAX6733 are offered in a tiny SOT23-6 package. The MAX6734/MAX6735 are offered in a space-saving SOT23-8 package. All devices are fully specified over the extended -40°C to $+85^{\circ}\text{C}$ temperature range.

Applications

- Multivoltage Systems
- Telecom/Networking Equipment
- Computers/Servers
- Portable/Battery-Operated Equipment
- Industrial Equipment
- Printer/Fax
- Set-Top Boxes
- Automotive

Benefits and Features

- V_{CC1} (Primary Supply) Reset Threshold Voltages from +1.575V to +4.63V
- V_{CC2} (Secondary Supply) Reset Threshold Voltages from +0.79V to +3.08V
- Adjustable RSTIN Threshold for Monitoring Voltages Down to +0.63V (MAX6734/MAX6735 Only)
- Six Reset Timeout Options
- Watchdog Timer with Independent Watchdog Output
 - 35s (min) Initial Watchdog Startup Period
 - 1.12s (min) Normal Watchdog Timeout Period
- Manual Reset Input (MAX6730/MAX6731/MAX6734/MAX6735)
- Guaranteed Reset Valid down to V_{CC1} or $V_{CC2} = +0.8\text{V}$
- Push-Pull $\overline{\text{RESET}}$ or Open-Drain $\overline{\text{RESET}}$ Output
- Immune to Short V_{CC} Transients
- Low Supply Current: $14\mu\text{A}$ (typ) at +3.6V
- Small 6-Pin and 8-Pin SOT23 Packages
- AEC-Q100 Qualified: MAX6734KATGD3/V+T, MAX6734KALTD3/V+T

Pin Configurations appear at end of data sheet.

Typical Operating Circuit

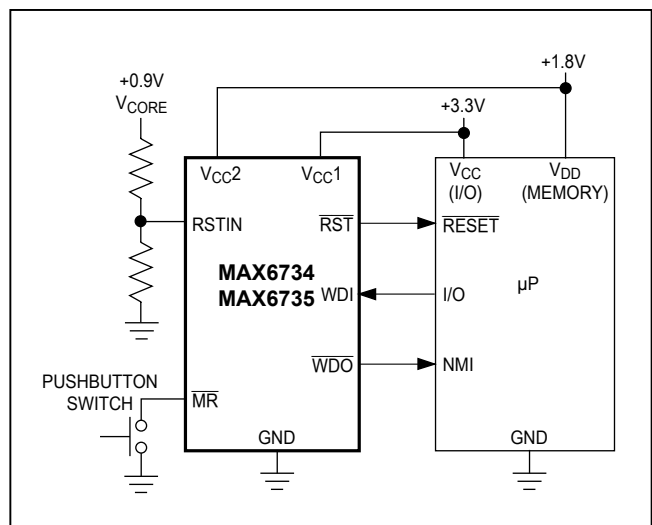

Absolute Maximum Ratings

V_{CC1} , V_{CC2} , RSTIN, \overline{MR} , WDI to GND.....	-0.3V to +6V	Operating Temperature Range.....	-40°C to +85°C
\overline{RST} , \overline{WDO} to GND (open drain).....	-0.3V to +6V	Storage Temperature Range.....	-65°C to +150°C
\overline{RST} , \overline{WDO} to GND (push-pull).....	-0.3V to ($V_{CC1} + 0.3V$)	Junction Temperature.....	+150°C
Input Current/Output Current (all pins).....	20mA	Lead Temperature (soldering, 10s).....	+300°C
Continuous Power Dissipation ($T_A = +70^\circ C$)		Soldering Temperature (reflow)	
6-Pin SOT23-6 (derate 4.3mW/°C above +70°C)....	347.8mW	Lead (Pb)-free packages.....	+260°C
8-Pin SOT23-8 (derate 5.6mW/°C above +70°C)....	444.4mW	Package containing lead (Pb).....	+240°C

Stresses beyond those listed under "Absolute Maximum Ratings" may cause permanent damage to the device. These are stress ratings only, and functional operation of the device at these or any other conditions beyond those indicated in the operational sections of the specifications is not implied. Exposure to absolute maximum rating conditions for extended periods may affect device reliability.

Package Thermal Characteristics (Note 1)

6 SOT23	Junction-to-Ambient Thermal Resistance (θ_{JA}).....	230°C/W	8 SOT23	Junction-to-Ambient Thermal Resistance (θ_{JA}).....	180°C/W
	Junction-to-Case Thermal Resistance (θ_{JC}).....	76°C/W		Junction-to-Case Thermal Resistance (θ_{JC}).....	60°C/W

Note 1: Package thermal resistances were obtained using the method described in JEDEC specification JESD51-7, using a four-layer board. For detailed information on package thermal considerations, refer to www.maximintegrated.com/thermal-tutorial.

Electrical Characteristics

($V_{CC1} = V_{CC2} = +0.8V$ to +5.5V, $T_A = -40^\circ C$ to +85°C, unless otherwise noted. Typical values are at $T_A = +25^\circ C$.) (Note 2)

PARAMETER	SYMBOL	CONDITIONS	MIN	TYP	MAX	UNITS
Supply Voltage	V_{CC1} , V_{CC2}		0.8		5.5	V
Supply Current	I_{CC1}	$V_{CC1} < +5.5V$, all I/O connections open, outputs not asserted		15	39	μA
		$V_{CC1} < +3.6V$, all I/O connections open, outputs not asserted		10	28	
	I_{CC2}	$V_{CC2} < +3.6V$, all I/O connections open, outputs not asserted		4	11	
		$V_{CC2} < +2.75V$, all I/O connections open, outputs not asserted		3	9	
V_{CC1} Reset Threshold	V_{TH1}	L (falling)	4.500	4.625	4.750	V
		M (falling)	4.250	4.375	4.500	
		T (falling)	3.000	3.075	3.150	
		S (falling)	2.850	2.925	3.000	
		R (falling)	2.550	2.625	2.700	
		Z (falling)	2.250	2.313	2.375	
		Y (falling)	2.125	2.188	2.250	
		W (falling)	1.620	1.665	1.710	
V (falling)	1.530	1.575	1.620			

Electrical Characteristics (continued)

(V_{CC1} = V_{CC2} = +0.8V to +5.5V, T_A = -40°C to +85°C, unless otherwise noted. Typical values are at T_A = +25°C.) (Note 2)

PARAMETER	SYMBOL	CONDITIONS	MIN	TYP	MAX	UNITS
V _{CC2} Reset Threshold	V _{TH2}	T (falling)	3.000	3.075	3.150	V
		S (falling)	2.850	2.925	3.000	
		R (falling)	2.550	2.625	2.700	
		Z (falling)	2.250	2.313	2.375	
		Y (falling)	2.125	2.188	2.250	
		W (falling)	1.620	1.665	1.710	
		V (falling)	1.530	1.575	1.620	
		I (falling)	1.350	1.388	1.425	
		H (falling)	1.275	1.313	1.350	
		G (falling)	1.080	1.110	1.140	
		F (falling)	1.020	1.050	1.080	
		E (falling)	0.810	0.833	0.855	
		D (falling)	0.765	0.788	0.810	
Reset Threshold Tempco				20		ppm/°C
Reset Threshold Hysteresis	V _{HYST}	Referenced to V _{TH} typical		0.5		%
V _{CC_} to $\overline{\text{RST}}$ Output Delay	t _{RD}	V _{CC1} = (V _{TH1} + 100mV) to (V _{TH1} - 100mV) or V _{CC2} = (V _{TH2} + 75mV) to (V _{TH2} - 75mV)		45		μ s
Reset Timeout Period	t _{RP}	D1	1.1	1.65	2.2	ms
		D2	8.8	13.2	17.6	
		D3	140	210	280	
		D5	280	420	560	
		D6	560	840	1120	
		D4	1120	1680	2240	
ADJUSTABLE RESET COMPARATOR INPUT (MAX6734/MAX6735)						
RSTIN Input Threshold	V _{RSTIN}		611	626.5	642	mV
RSTIN Input Current	I _{RSTIN}		-25		+25	nA
RSTIN Hysteresis				3		mV
RSTIN to Reset Output Delay	t _{RSTIND}	V _{RSTIN} to (V _{RSTIN} - 30mV)		22		μ s
MANUAL RESET INPUT (MAX6730/MAX6731/MAX6734/MAX6735)						
$\overline{\text{MR}}$ Input Threshold	V _{IL}			0.3 x V _{CC1}		V
	V _{IH}		0.7 x V _{CC1}			
$\overline{\text{MR}}$ Minimum Pulse Width			1		μ s	
$\overline{\text{MR}}$ Glitch Rejection			100		ns	
$\overline{\text{MR}}$ to Reset Output Delay	t _{MR}		200		ns	
$\overline{\text{MR}}$ Pullup Resistance			25	50	80	k Ω

Electrical Characteristics (continued)

(V_{CC1} = V_{CC2} = +0.8V to +5.5V, T_A = -40°C to +85°C, unless otherwise noted. Typical values are at T_A = +25°C.) (Note 2)

PARAMETER	SYMBOL	CONDITIONS	MIN	TYP	MAX	UNITS
WATCHDOG INPUT						
Watchdog Timeout Period	t _{WD-L}	First watchdog period after reset timeout period	35	54	72	s
	t _{WD-S}	Normal mode	1.12	1.68	2.24	
WDI Pulse Width	t _{WDI}	(Note 3)	50			ns
WDI Input Voltage	V _{IL}				0.3 x V _{CC1}	V
	V _{IH}		0.7 x V _{CC1}			
WDI Input Current	I _{WDI}	WDI = 0 or V _{CC1}	-1		+1	μ A
RESET/WATCHDOG OUTPUT						
$\overline{\text{RST}}/\overline{\text{WDO}}$ Output Low Voltage (Push-Pull or Open Drain)	V _{OL}	V _{CC1} or V _{CC2} \geq +0.8V, I _{SINK} = 1 μ A, output asserted			0.3	V
		V _{CC1} or V _{CC2} \geq +1.0V, I _{SINK} = 50 μ A, output asserted			0.3	
		V _{CC1} or V _{CC2} \geq +1.2V, I _{SINK} = 100 μ A, output asserted			0.3	
		V _{CC1} or V _{CC2} \geq +2.7V, I _{SINK} = 1.2mA, output asserted			0.3	
		V _{CC1} or V _{CC2} \geq +4.5V, I _{SINK} = 3.2mA, output asserted			0.4	
$\overline{\text{RST}}/\overline{\text{WDO}}$ Output High Voltage (Push-Pull Only)	V _{OH}	V _{CC1} \geq +1.8V, I _{SOURCE} = 200 μ A, output not asserted	0.8 x V _{CC1}			V
		V _{CC1} \geq +2.7V, I _{SOURCE} = 500 μ A, output not asserted	0.8 x V _{CC1}			
		V _{CC1} \geq +4.5V, I _{SOURCE} = 800 μ A, output not asserted	0.8 x V _{CC1}			
$\overline{\text{RST}}/\overline{\text{WDO}}$ Output Open-Drain Leakage Current		Output not asserted			0.5	μ A

Note 2: Devices tested at T_A = +25°C. Overtemperature limits are guaranteed by design and not production tested.**Note 3:** Parameter guaranteed by design.

Typical Operating Characteristics

($V_{CC1} = +5V$, $V_{CC2} = +3.3V$, $T_A = +25^\circ C$, unless otherwise noted.)

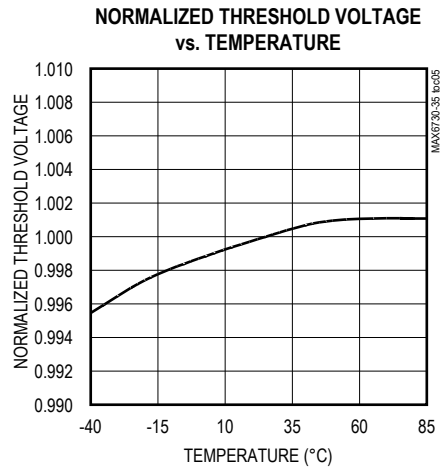
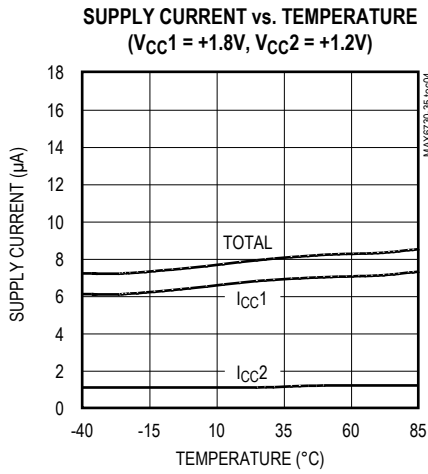
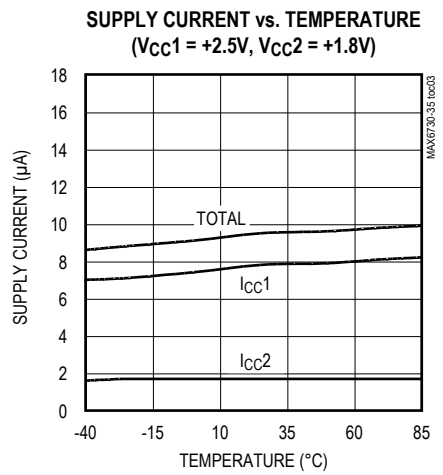
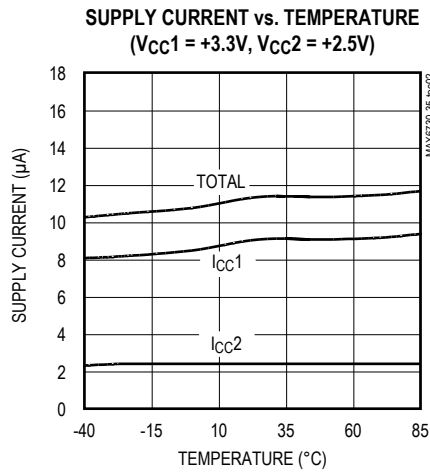
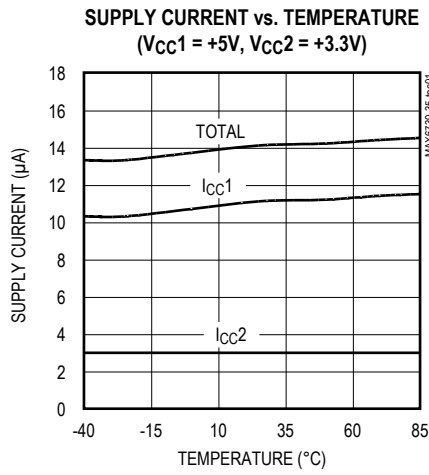

Typical Operating Characteristics (continued)

($V_{CC1} = +5V$, $V_{CC2} = +3.3V$, $T_A = +25^\circ C$, unless otherwise noted.)

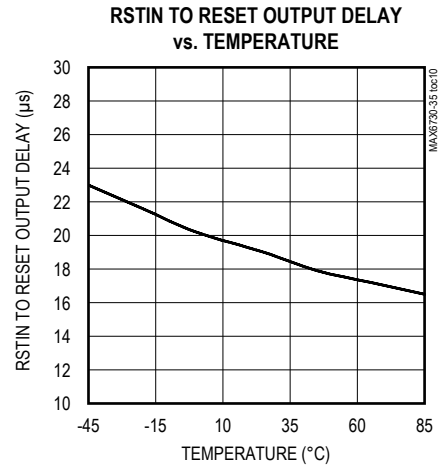
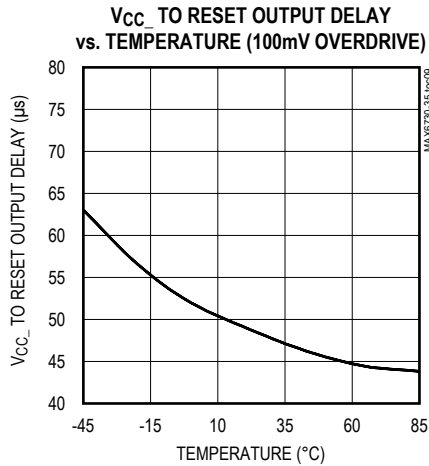
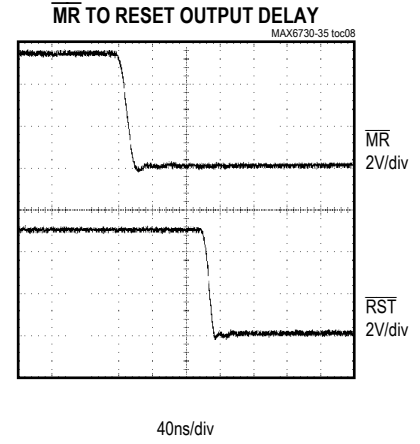
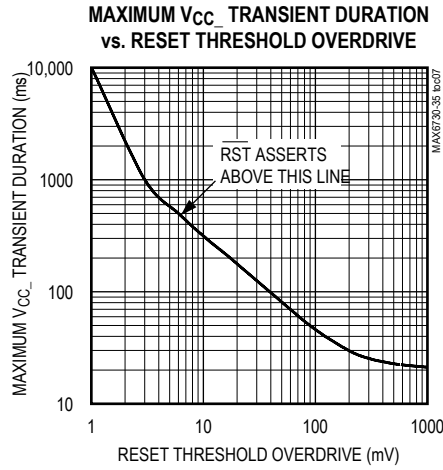
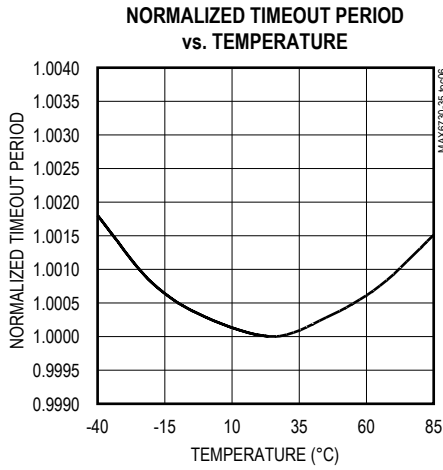

Pin Configurations

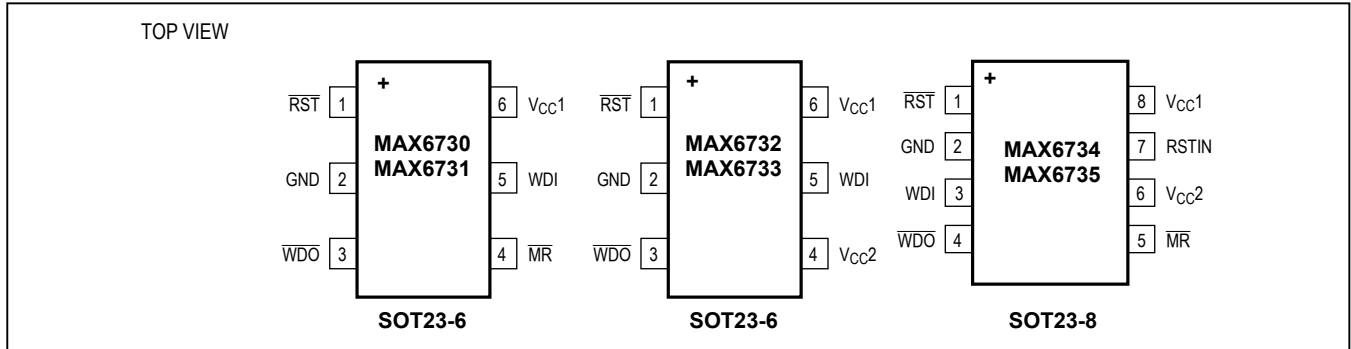

Pin Description

PIN			NAME	FUNCTION
MAX6730 MAX6731	MAX6732 MAX6733	MAX6734 MAX6735		
1	1	1	RST	Active-Low Reset Output. The MAX6730/MAX6732/MAX6734 provide an open-drain output. The MAX6731/MAX6733/MAX6735 provide a push-pull output. $\overline{\text{RST}}$ asserts low when any of the following conditions occur: V_{CC1} or V_{CC2} drops below its preset threshold, RSTIN drops below its reset threshold, or MR is driven low. Open-drain versions require an external pullup resistor.
2	2	2	GND	Ground
3	3	4	$\overline{\text{WDO}}$	Active-Low Watchdog Output. The MAX6730/MAX6732/MAX6734 provide an open-drain $\overline{\text{WDO}}$ output. The MAX6731/MAX6733/MAX6735 provide a push-pull $\overline{\text{WDO}}$ output. $\overline{\text{WDO}}$ asserts low when no low-to-high or high-to-low transition occurs on WDI within the watchdog timeout period (t_{WD}) or if an undervoltage lockout condition exists for V_{CC1} , V_{CC2} , or RSTIN. $\overline{\text{WDO}}$ deasserts without a timeout period when V_{CC1} , V_{CC2} , and RSTIN exceed their reset thresholds, or when the manual reset input is asserted. Open-drain versions require an external pullup resistor.
4	—	5	$\overline{\text{MR}}$	Active-Low Manual Reset Input. Drive $\overline{\text{MR}}$ low to force a reset. $\overline{\text{RST}}$ remains asserted as long as $\overline{\text{MR}}$ is low and for the reset timeout period after $\overline{\text{MR}}$ releases high. $\overline{\text{MR}}$ has a 50k Ω pullup resistor to V_{CC1} ; leave $\overline{\text{MR}}$ open or connect to V_{CC1} if unused.
5	5	3	WDI	Watchdog Input. If WDI remains high or low for longer than the watchdog timeout period, the internal watchdog timer expires and the watchdog output asserts low. The internal watchdog timer clears whenever $\overline{\text{RST}}$ asserts or a rising or falling edge on WDI is detected. The watchdog has an initial watchdog timeout period (35s min) after each reset event and a short timeout period (1.12s min) after the first valid WDI transition. Leaving WDI unconnected does not disable the watchdog timer function. Connect WDI to ground with a 100k (max) resistor if not driven externally with a logic level input.
6	6	8	V_{CC1}	Primary Supply-Voltage Input. V_{CC1} provides power to the device when it is greater than V_{CC2} . V_{CC1} is the input to the primary reset threshold monitor.
—	4	6	V_{CC2}	Secondary Supply-Voltage Input. V_{CC2} provides power to the device when it is greater than V_{CC1} . V_{CC2} is the input to the secondary reset threshold monitor.
—	—	7	RSTIN	Undervoltage Reset Comparator Input. RSTIN provides a high-impedance comparator input for the adjustable reset monitor. $\overline{\text{RST}}$ asserts low if the voltage at RSTIN drops below the 626mV internal reference voltage. Connect a resistive voltage-divider to RSTIN to monitor voltages higher than 626mV. Connect RSTIN to V_{CC1} or V_{CC2} if unused.

**Table 1. Reset Voltage Threshold Suffix
Guide****

PART NO. SUFFIX	V _{CC1} NOMINAL VOLTAGE THRESHOLD(V)	V _{CC2} NOMINAL VOLTAGE THRESHOLD (V)
LT	4.625	3.075
MS	4.375	2.925
MR	4.375	2.625
TZ	3.075	2.313
SY	2.925	2.188
RY	2.625	2.188
TW	3.075	1.665
SV	2.925	1.575
RV	2.625	1.575
TI	3.075	1.388
SH	2.925	1.313
RH	2.625	1.313
TG	3.075	1.110
SF	2.925	1.050
RF	2.625	1.050
TE	3.075	0.833
SD	2.925	0.788
RD	2.625	0.788
ZW	2.313	1.665
YV	2.188	1.575
ZI	2.313	1.388
YH	2.188	1.313
ZG	2.313	1.110
YF	2.188	1.050
ZE	2.313	0.833
YD	2.188	0.788
WI	1.665	1.388
VH	1.575	1.313
WG	1.665	1.110
VF	1.575	1.050
WE	1.665	0.833
VD	1.575	0.788

**Standard versions are shown in bold and are available in a D3 timeout option only. Standard versions require 2500-piece order increments and are typically held in sample stock. There is a 10,000-piece order increment on nonstandard versions.

Other threshold voltages may be available; contact factory for availability.

**Table 2. Reset Timeout Period Suffix
Guide**

TIMEOUT PERIOD SUFFIX	ACTIVE TIMEOUT PERIOD	
	MIN (ms)	MAX (ms)
D1	1.1	2.2
D2	8.8	17.6
D3	140	280
D5	280	560
D6	560	1120
D4	1120	2240

Detailed Description

Supply Voltages

The MAX6730–MAX6735 microprocessor (μ P) supervisors maintain system integrity by alerting the μ P to fault conditions. The MAX6730–MAX6735 monitor one to three supply voltages in μ P-based systems and assert an active-low reset output when any monitored supply voltage drops below its preset threshold. The output state remains valid for V_{CC1} or V_{CC2} greater than +0.8V.

Threshold Levels

The two-letter code in the Reset Voltage Threshold Suffix Guide (Table 1) indicates the threshold level combinations for V_{CC1} and V_{CC2}.

Reset Output

The MAX6730–MAX6735 feature an active-low reset output (\overline{RST}). \overline{RST} asserts when the voltage at either V_{CC1} or V_{CC2} falls below the voltage threshold level, V_{RSTIN} drops below its threshold, or \overline{MR} is driven low (Figure 1). \overline{RST} remains low for the reset timeout period (Table 2) after V_{CC1}, V_{CC2}, and RSTIN increase above their respective thresholds and after \overline{MR} releases high. Whenever V_{CC1}, V_{CC2}, or RSTIN go below the reset threshold before the end of the reset timeout period, the internal timer restarts. The MAX6730/MAX6732/ MAX6734 provide an open-drain \overline{RST} output, and the MAX6731/MAX6733/MAX6735 provide a push-pull \overline{RST} output.

Manual Reset Input

Many μ P-based products require manual reset capability, allowing the operator, a test technician, or external logic circuitry to initiate a reset. A logic low on \overline{MR} asserts the reset output, clears the watchdog timer, and deasserts the watchdog output. Reset remains asserted while \overline{MR} is low and for the reset timeout period (t_{RP}) after \overline{MR} returns high. An internal 50k Ω pullup resistor allows \overline{MR} to be left open if unused. Drive \overline{MR} with TTL or CMOS-logic levels or with open-drain/collector outputs. Connect a normally open momentary switch from \overline{MR} to GND to create a manual reset function; external debounce circuitry is not required. Connect a 0.1 μ F capacitor from \overline{MR} to GND to provide additional noise immunity when driving \overline{MR} over long cables or if the device is used in a noisy environment.

Adjustable Input Voltage (RSTIN)

The MAX6734/MAX6735 provide an additional high-impedance comparator input with a 626mV threshold to monitor a third supply voltage. To monitor a voltage higher than 626mV, connect a resistive-divider to the circuit as shown in [Figure 2](#) to establish an externally controlled threshold voltage, V_{EXT_TH} .

$$V_{EXT_TH} = 626mV \times \frac{(R1+R2)}{R2}$$

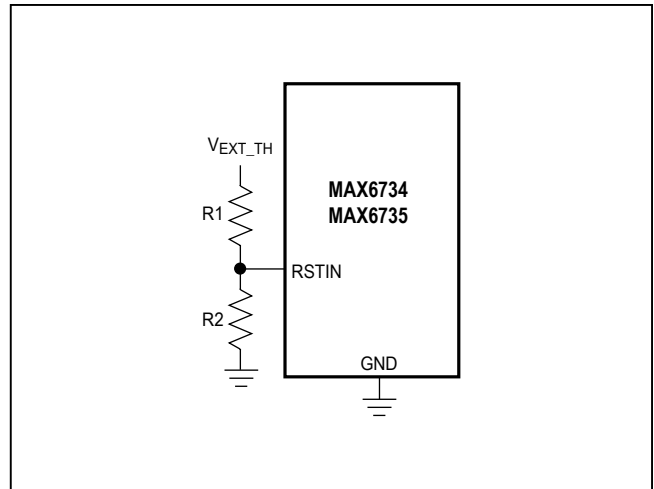

Figure 2. Monitoring a Third Voltage

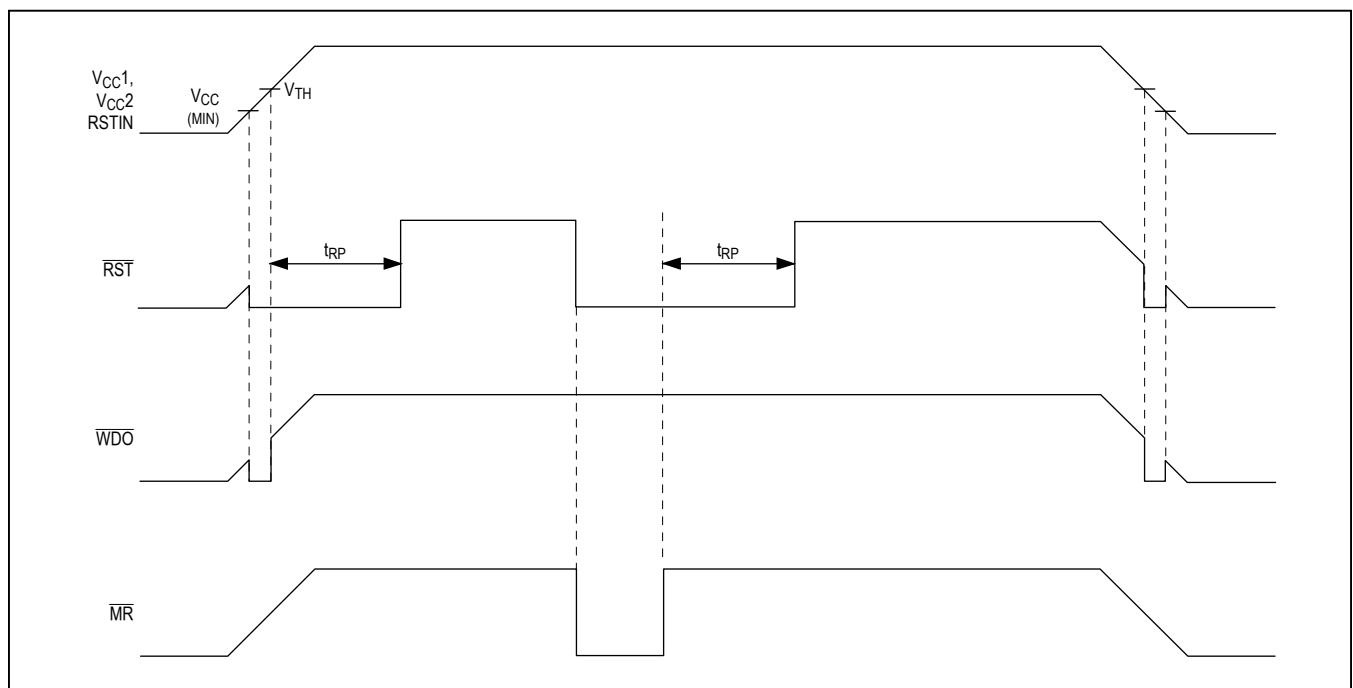

Figure 1. \overline{RST} , \overline{WDO} , and \overline{MR} Timing Diagram

The RSTIN comparator derives power from V_{CC1} , and the input voltage must remain less than or equal to V_{CC1} . Low leakage current at RSTIN allows the use of large-valued resistors, resulting in reduced power consumption of the system.

Watchdog

The watchdog feature monitors μ P activity through the watchdog input (WDI). A rising or falling edge on WDI within the watchdog timeout period (t_{WD}) indicates normal μ P operation. \overline{WDO} asserts low if WDI remains high or low for longer than the watchdog timeout period. Leaving WDI unconnected does not disable the watchdog timer. Connect WDI to ground with a 100k (max) resistor if not driven externally with a logic level input.

The devices include a dual-mode watchdog timer to monitor μ P activity. The flexible timeout architecture provides a long-period initial watchdog mode, allowing complicated systems to complete lengthy boots, and a short-period normal watchdog mode, allowing the supervisor to provide quick alerts when processor activity fails. After each reset event (V_{CC} power-up, brownout, or manual reset), there is a long initial watchdog period of 35s (min). The long watchdog period mode provides an extended time for the system to power up and fully initialize all μ P and system components before assuming responsibility for routine watchdog updates.

The usual watchdog timeout period (1.12s min) begins after the initial watchdog timeout period (t_{WD-L}) expires or after the first transition on WDI (Figure 3). During normal operating mode, the supervisor asserts the \overline{WDO} output if the μ P does not update the WDI with a valid transition (high to low or low to high) within the standard timeout period (t_{WD-S}) (1.12s min).

Connect \overline{MR} to \overline{WDO} to force a system reset in the event that no rising or falling edge is detected at WDI within the watchdog timeout period. \overline{WDO} asserts low when no edge is detected by WDI, the \overline{RST} output asserts low, the watchdog counter immediately clears, and \overline{WDO} returns high. The watchdog counter restarts, using the long watchdog period, when the reset timeout period ends (Figure 4).

Ensuring a Valid RESET Output Down to $V_{CC} = 0V$

The MAX6730–MAX6735 guarantee proper operation down to $V_{CC} = +0.8V$. In applications that require valid reset levels down to $V_{CC} = 0V$, use a 100k Ω pulldown resistor from \overline{RST} to GND. The resistor value used is not critical, but it must be large enough not to load the reset output when V_{CC} is above the reset threshold. For most applications, 100k Ω is adequate. Note that this configuration does not work for the open-drain outputs of MAX6730/MAX6732/MAX6734.

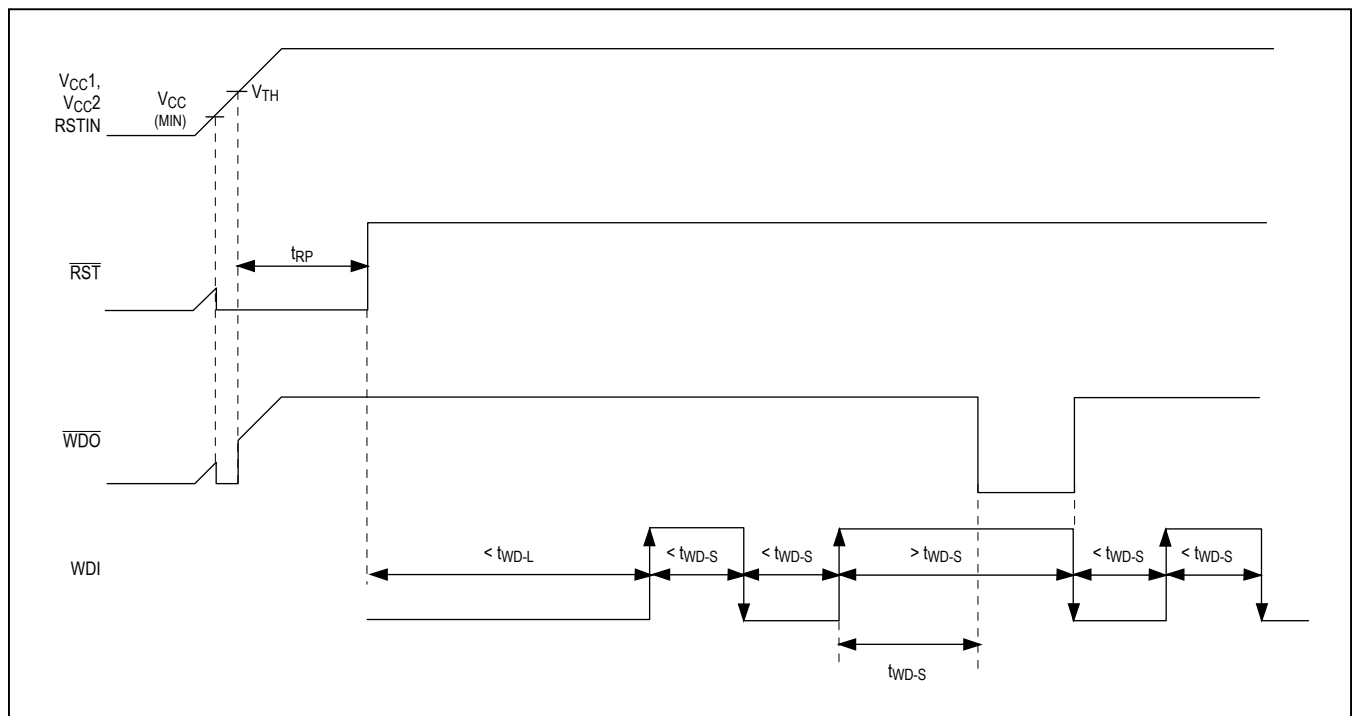

Figure 3. Watchdog Input/Output Timing Diagram (\overline{MR} and \overline{WDO} Not Connected)

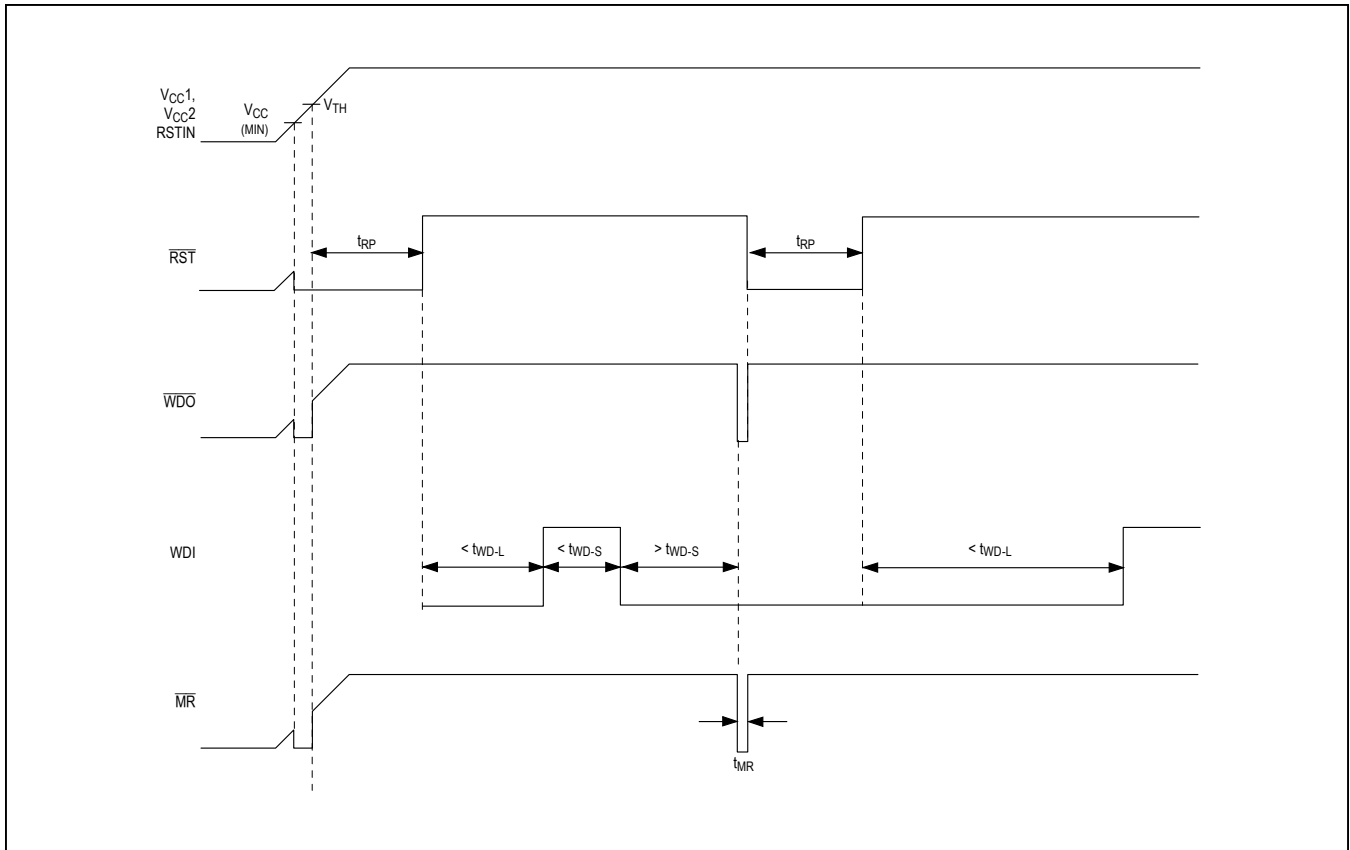

Figure 4. Watchdog Input/Output Timing Diagram (\overline{MR} and \overline{WDO} Connected)

Applications Information

Interfacing to μ Ps with Bidirectional Reset Pins

Microprocessors with bidirectional reset pins can interface directly with the open-drain \overline{RST} output options. However, conditions might occur in which the push-pull output versions experience logic contention with the bidirectional reset pin of the μ P. Connect a 10k Ω resistor between \overline{RST} and the μ P's reset I/O port to prevent logic contention (Figure 5).

Falling V_{CC} Transients

The devices μ P supervisors are relatively immune to short-duration falling V_{CC} transients (glitches). Small glitches on V_{CC} are ignored by the MAX6730–MAX6735, preventing undesirable reset pulses to the μ P. The *Typical Operating Characteristics* show Maximum Transient Duration vs. Reset Threshold Overdrive, for which reset

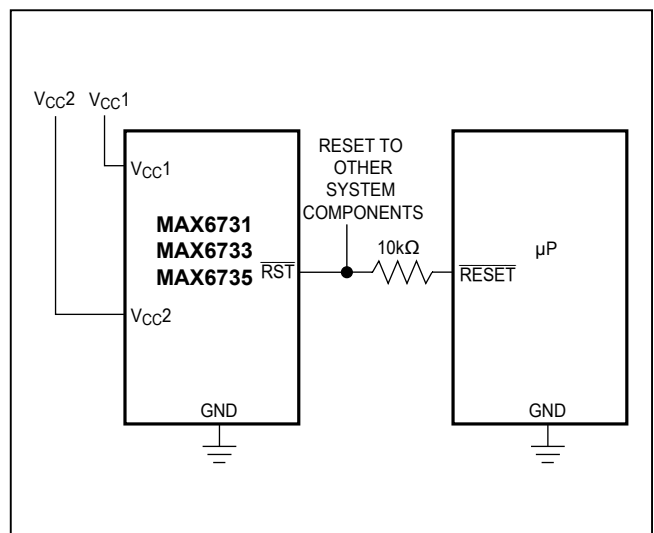

Figure 5. Interfacing to μ Ps with Bidirectional Reset I/O

pulses are not generated. The graph was produced using falling V_{CC} pulses, starting above V_{TH} and ending below the reset threshold by the magnitude indicated (reset threshold overdrive). The graph shows the maximum pulse width that a falling V_{CC} transient typically might have without causing a reset pulse to be issued. As the amplitude of the transient increases (i.e., goes further below the reset threshold), the maximum allowable pulse width decreases. A $0.1\mu\text{F}$ bypass capacitor mounted close to V_{CC} provides additional transient immunity.

Watchdog Software Considerations

Setting and resetting the watchdog input at different points in the program rather than “pulsing” the watchdog input high-low-high or low-high-low helps the watchdog timer closely monitor software execution. This technique avoids a “stuck” loop, in which the watchdog timer continues to be reset within the loop, preventing the watchdog from timing out. Figure 6 shows an example flow diagram in which the I/O driving the watchdog input is set high at the beginning of the program, set low at the beginning of every subroutine or loop, and then set high again when the program returns to the beginning. If the program “hangs” in any subroutine, the I/O continually asserts low (or high), and the watchdog timer expires, issuing a reset or interrupt.

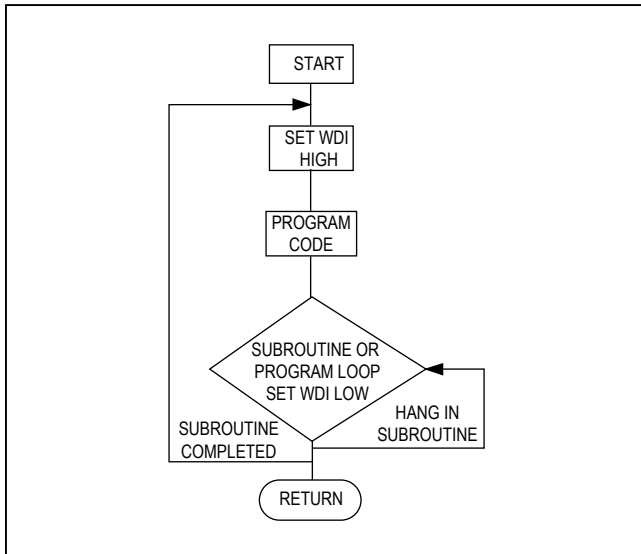
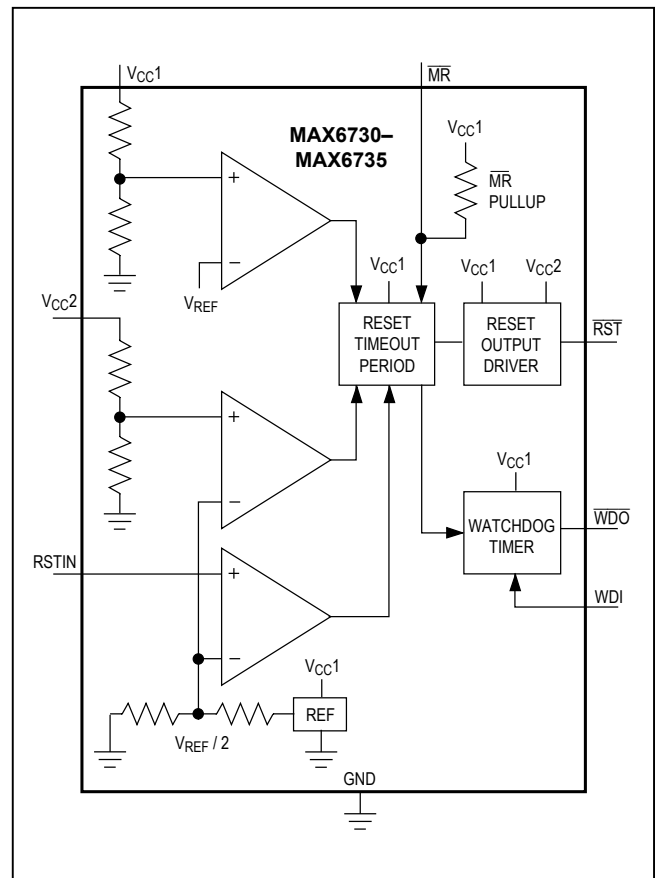

Figure 6. Watchdog Flow Diagram

Functional Diagram



Selector Guide

PART NUMBER	VOLTAGE MONITORS	$\overline{\text{RST}}$ OUTPUT	MANUAL RESET	WATCHDOG INPUT	WATCHDOG OUTPUT
MAX6730	1	Open Drain	√	√	Open Drain
MAX6731	1	Push-Pull	√	√	Push-Pull
MAX6732	2	Open Drain	—	√	Open Drain
MAX6733	2	Push-Pull	—	√	Push-Pull
MAX6734	3	Open Drain	√	√	Open Drain
MAX6735	3	Push-Pull	√	√	Push-Pull

Ordering Information

PART*	TEMP RANGE	PIN-PACKAGE
MAX6730UT__D_+T	-40°C to +85°C	6 SOT23
MAX6731UT__D_+T	-40°C to +85°C	6 SOT23
MAX6732UT__D_+T	-40°C to +85°C	6 SOT23
MAX6733UT__D_-T	-40°C to +85°C	6 SOT23
MAX6734KA__D_-T	-40°C to +85°C	8 SOT23
MAX6734KA__D_+T	-40°C to +85°C	8 SOT23
MAX6734KA__D_/V+T	-40°C to +85°C	8 SOT23
MAX6734KATGD3/V+T	-40°C to +85°C	8 SOT23
MAX6734KALTD3/V+T	-40°C to +85°C	8 SOT23
MAX6735KA__D_+T	-40°C to +85°C	8 SOT23

*Insert the threshold level suffixes for V_{CC1} and V_{CC2} (Table 1) after “UT” or “KA.” For the MAX6730/MAX6731, insert only the V_{CC1} threshold suffix after the “UT.” Insert the reset timeout delay (Table 2) after “D” to complete the part number. For example, the MAX6732UTLTD3+T provides a V_{CC1} threshold of +4.625V, a V_{CC2} threshold of +3.075V, and a 210ms reset timeout period. Sample stock is generally held on standard versions only. Standard versions have an order increment requirement of 2500 pieces. Nonstandard versions have an order increment requirement of 10,000 pieces. Contact factory for availability.

+Denotes Lead(Pb)-free packages and - denotes leaded packages. Not all MAX6734KA__D_ options are available with leaded (-T) packages. See <https://www.maximintegrated.com> for available leaded options.

Some devices are available in both leaded and lead(Pb)-free/RoHS compliant packaging.

For top mark information, please go to <https://www.maximintegrated.com/en/design/packaging/topmark/>

/V denotes an automotive qualified part.

Package Information

For the latest package outline information and land patterns (footprints), go to www.maximintegrated.com/packages. Note that a “+”, “#”, or “-” in the package code indicates RoHS status only. Package drawings may show a different suffix character, but the drawing pertains to the package regardless of RoHS status.

PACKAGE TYPE	PACKAGE CODE	OUTLINE NO.	LAND PATTERN NO.
6 SOT23	U6+1, U6-1 (MAX6733 only)	21-0058	90-0175
8 SOT23	K8SN-1 (MAX6734 only), K8SN+1	21-0078	90-0176

Chip Information

PROCESS: BiCMOS

Revision History

REVISION NUMBER	REVISION DATE	DESCRIPTION	PAGES CHANGED
0	10/02	Initial release.	—
1	12/02	Released MAX6730/MAX6731.	1
2	1/03	Released MAX6733.	1
3	3/04	Updated <i>Typical Operating Circuit</i> .	14
4	12/05	Added lead-free notation to <i>Ordering Information</i> .	1
5	3/09	Updated <i>Pin Description</i> and added <i>Package Table</i> .	7, 14
6	11/11	Added automotive-qualified part information	1
7	4/13	Added <i>Package Thermal Characteristics</i> and corrected power dissipation errors and package code for 8 SOT23	2–4, 14
8	12/15	Added lead-free part numbers to <i>Ordering Information</i> table, updated <i>Package Information</i> table, and removed <i>Standard Versions</i> table.	1, 13, 14
9	10/17	Added AEC qualification statement to <i>Benefits and Features</i> section and updated <i>Ordering Information</i> table	1, 13
10	3/19	Updated <i>Applications</i> , <i>Pin Description</i> , and <i>Watchdog</i> section	1, 7, 10

For pricing, delivery, and ordering information, please visit Maxim Integrated's online storefront at <https://www.maximintegrated.com/en/storefront/storefront.html>.

Maxim Integrated cannot assume responsibility for use of any circuitry other than circuitry entirely embodied in a Maxim Integrated product. No circuit patent licenses are implied. Maxim Integrated reserves the right to change the circuitry and specifications without notice at any time. The parametric values (min and max limits) shown in the Electrical Characteristics table are guaranteed. Other parametric values quoted in this data sheet are provided for guidance.

Looking for pricing, stock, or lifecycle information?

Click below to explore more details on WIN SOURCE:

 [View MAX6734KATZD3+T on WIN SOURCE](#)

 [Maxim Integrated](#) Information

Optimize Your Supply Chain with WIN SOURCE Solutions

-  Global Sourcing Solution
-  Obsolete Management
-  Cost Control Management
-  Shortage Management
-  Alternative Solution
-  Excess Inventory Management