



**THE DATASHEET OF  
MAX6683AUB+T**



# Temperature Sensor and System Monitor in a 10-Pin $\mu$ MAX

## General Description

The MAX6683 system supervisor monitors multiple power-supply voltages, including its own, and also features an on-board temperature sensor. The MAX6683 converts voltages to an 8-bit code and temperatures to an 11-bit (10-bit-plus-sign) code using an analog-to-digital converter (ADC). A multiplexer automatically sequences through the voltage and temperature measurements. The digitized signals are then stored in registers and compared to the over/underthreshold limits programmed over the SMBus™/I<sup>2</sup>C™-compatible 2-wire serial interface.

When a temperature measurement exceeds the programmed threshold, or when an input voltage falls outside the programmed voltage limits, the MAX6683 generates a latched interrupt output  $\overline{\text{ALERT}}$ . Three interrupt modes are available for temperature excursions. These are default mode, one-time interrupt mode, and comparator mode. The  $\overline{\text{ALERT}}$  output is cleared, except for temperature interrupts generated in comparator mode, by reading the Interrupt Status register (Table 5). The  $\overline{\text{ALERT}}$  output can also be masked by writing to the appropriate bits in the Interrupt Mask register (Table 6) or by setting bit 1 of the Configuration register (Table 4) to zero. The MAX6683 SMBus/I<sup>2</sup>C-compatible interface also responds to the SMB alert response address.

## Applications

Workstations  
Servers  
Networking  
Telecommunications

## Typical Application Circuit

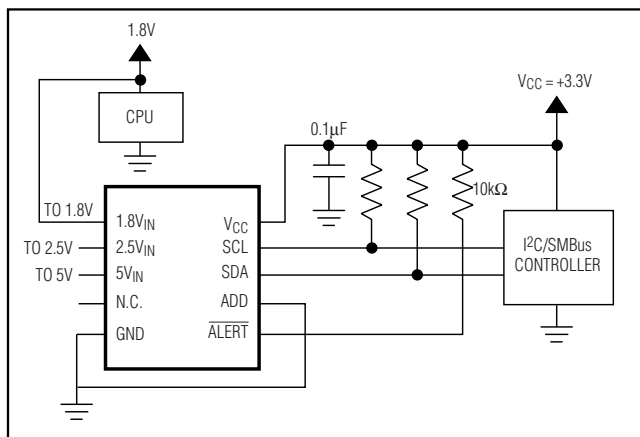

## Features

- ◆ Monitors Local Temperature
- ◆ Monitors Three External Voltages (1.8V, 2.5V, 5V Nominal)
- ◆ Monitors V<sub>CC</sub> (3.3V Nominal)
- ◆ User-Programmable Voltage and Temperature Thresholds
- ◆ Alert Function with Ability to Respond to SMB Alert Response Address
- ◆ +2.7V to +5.5V Supply Range
- ◆ -40°C to +125°C Temperature Range
- ◆ 60Hz or 50Hz Line-Frequency Rejection
- ◆ Tiny 10-Pin  $\mu$ MAX Package
- ◆ MAX6683EVKIT Available

## Ordering Information

PART	TEMP RANGE	PIN-PACKAGE
MAX6683AUB	-40°C to +125°C	10 $\mu$ MAX

## Pin Configuration

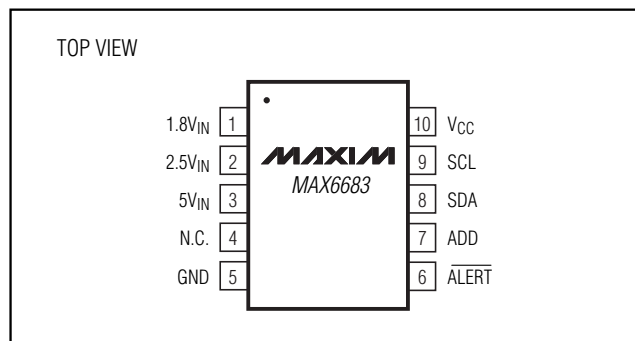

SMBus is a trademark of Intel Corp.  
I<sup>2</sup>C is a trademark of Philips Corp.

# Temperature Sensor and System Monitor in a 10-Pin $\mu$ MAX

## ABSOLUTE MAXIMUM RATINGS

All Voltages Referenced to GND

All Pins .....-0.3V to +6.0V

SDA,  $\overline{\text{ALERT}}$  Current .....-1mA to +50mA

Continuous Power Dissipation ( $T_A = +70^\circ\text{C}$ )

10-Pin  $\mu$ MAX (derate 5.6mW/ $^\circ\text{C}$  above  $+70^\circ\text{C}$ ) .....444mW

Junction Temperature .....+150 $^\circ\text{C}$

Operating Temperature Range .....-40 $^\circ\text{C}$  to +125 $^\circ\text{C}$

Storage Temperature Range .....-65 $^\circ\text{C}$  to +150 $^\circ\text{C}$

Lead Temperature (soldering, 10s) .....+300 $^\circ\text{C}$

Stresses beyond those listed under "Absolute Maximum Ratings" may cause permanent damage to the device. These are stress ratings only, and functional operation of the device at these or any other conditions beyond those indicated in the operational sections of the specifications is not implied. Exposure to absolute maximum rating conditions for extended periods may affect device reliability.

## ELECTRICAL CHARACTERISTICS

( $T_A = -40^\circ\text{C}$  to  $+125^\circ\text{C}$ , unless otherwise noted. Typical values are at  $V_{CC} = +3.3\text{V}$ ,  $T_A = +25^\circ\text{C}$ .)

PARAMETER	SYMBOL	CONDITIONS	MIN	TYP	MAX	UNITS
<b>POWER SUPPLY</b>						
Supply Voltage	$V_{CC}$		2.7		5.5	V
Supply Current	$I_{CC}$	Operating		200	500	$\mu\text{A}$
	$I_{SD}$	Shutdown mode, interface inactive			10	
Power-On Reset (POR) Voltage		$V_{CC}$ , rising or falling edge		2		V
<b>TEMPERATURE</b>						
Accuracy		$T_A = +25^\circ\text{C}$ , $V_{CC} = +3.3\text{V}$			$\pm 3$	$^\circ\text{C}$
		$0^\circ\text{C} \leq T_A \leq +125^\circ\text{C}$ , $V_{CC} = +3.3\text{V}$			$\pm 4$	
		$-40^\circ\text{C} \leq T_A \leq +125^\circ\text{C}$ , $V_{CC} = +3.3\text{V}$			$\pm 6$	
Resolution		Read word mode		0.125		$^\circ\text{C}$
Supply Sensitivity	PSS			0.7	$\pm 1.5$	$^\circ\text{C}/\text{V}$
<b>ADC CHARACTERISTICS</b>						
Total Unadjusted Error	TUE	$V_{IN} > 10\text{LSBs}$			$\pm 1.5$	%
Differential Nonlinearity	DNL	$V_{IN} > 10\text{LSBs}$			$\pm 1$	LSB
Supply Sensitivity	PSS			$\pm 1$		LSB/V
Input Resistance	$R_{IN}$	$1.8V_{IN}$ , $2.5V_{IN}$ , $5V_{IN}$	100	150	200	$\text{k}\Omega$
Total Monitoring Cycle Time	$t_C$	(Note 1)		200	300	ms
<b>SCL, SDA, ADD</b>						
Logic Input Low Voltage	$V_{IL}$				0.8	V
Logic Input High Voltage	$V_{IH}$	$V_{CC} \leq 3.6\text{V}$	2.0			V
		$V_{CC} > 3.6\text{V}$	2.6			
Input Leakage Current	$I_{LEAK}$	$V_{IN} = 0$ or $5\text{V}$			$\pm 1$	$\mu\text{A}$
Output Low Voltage	$V_{OL}$	$I_{SINK} = 3\text{mA}$			400	mV
<b>ALERT</b>						
Output Low Voltage	$V_{OLA}$	$I_{SINK} = 1.2\text{mA}$ , $V_{CC} > 2.7\text{V}$			0.3	V
		$I_{SINK} = 3.2\text{mA}$ , $V_{CC} > 4.5\text{V}$			0.4	

# Temperature Sensor and System Monitor in a 10-Pin $\mu$ MAX

**MAX6683**

## ELECTRICAL CHARACTERISTICS (continued)

( $T_A = -40^\circ\text{C}$  to  $+125^\circ\text{C}$ , unless otherwise noted. Typical values are at  $V_{CC} = +3.3\text{V}$ ,  $T_A = +25^\circ\text{C}$ .)

PARAMETER	SYMBOL	CONDITIONS	MIN	TYP	MAX	UNITS
<b>TIMING</b> (Figures 3 and 4)						
Serial Clock Frequency	$f_{SCL}$		0		400	kHz
Bus Free Time Between Stop and Start	$T_{BUF}$		1.3			$\mu\text{s}$
Start Condition Hold Time	$t_{HD:STA}$		0.6			$\mu\text{s}$
Stop Condition Hold Time	$t_{SU:STO}$		0.6			$\mu\text{s}$
Clock Low Time	$T_{LOW}$		1.3			$\mu\text{s}$
Clock High Time	$T_{HIGH}$		0.6			$\mu\text{s}$
Data Setup Time	$t_{SU:DAT}$		100			ns
Data Hold Time	$t_{HD:DAT}$	(Note 2)	0		0.9	$\mu\text{s}$
Receive SCL/SDA Minimum Rise Time	$t_R$	(Note 3)		20 + 0.1 $C_b$		ns
Receive SCL/SDA Maximum Rise Time	$t_R$	(Note 3)		300		ns
Receive SCL/SDA Minimum Fall Time	$t_F$	(Note 3)		20 + 0.1 $C_b$		ns
Receive SCL/SDA Maximum Fall Time	$t_F$	(Note 3)		300		ns
Transmit SDA Fall Time	$t_F$	$C_b = 400\text{pF}$ , $I_{SINK} = 3\text{mA}$	20 + 0.1 $C_b$		300	ns
Pulse Width of Spike Suppressed	$t_{SP}$	(Note 4)		50		ns

**Note 1:** Total monitoring time includes temperature conversion and four analog input voltage conversions.

**Note 2:** A master device must provide at least a 300ns hold time for the SDA signal, referred to  $V_{IL}$  of the SCL signal, to bridge the undefined region of SCL's falling edge.

**Note 3:**  $C_b$  = total capacitance of one bus line in pF. Rise and fall times are measured between  $0.3 \times V_{CC}$  to  $0.7 \times V_{CC}$ .

**Note 4:** Input filters on SDA, SCL, and ADD suppress noise spikes <50ns.

# Temperature Sensor and System Monitor in a 10-Pin $\mu$ MAX

## Typical Operating Characteristics

( $V_{CC} = +3.3V$ , ADD = GND,  $T_A = +25^\circ C$ , unless otherwise noted.)

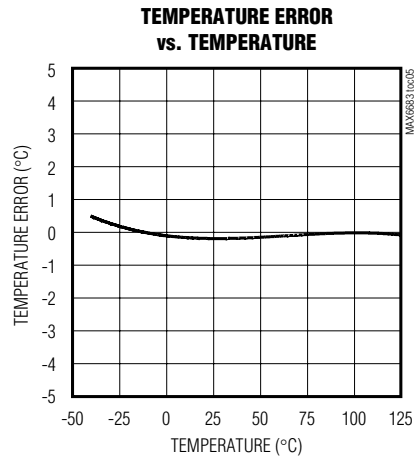
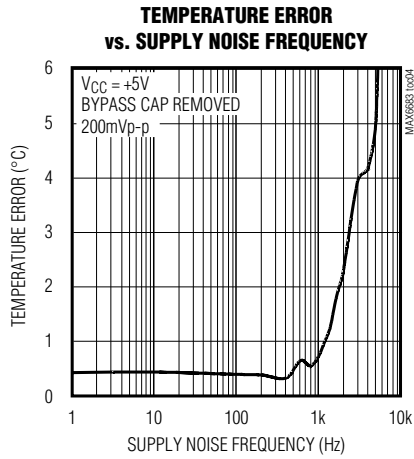
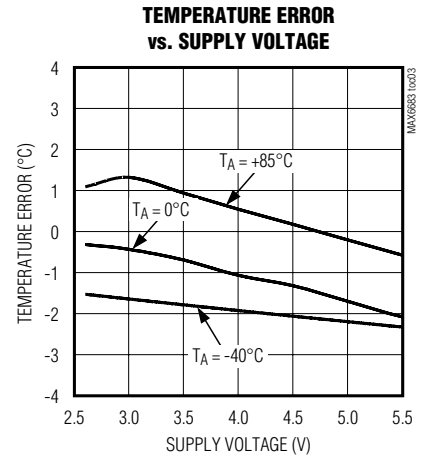
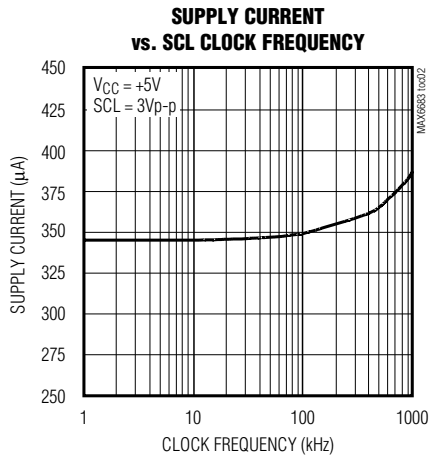
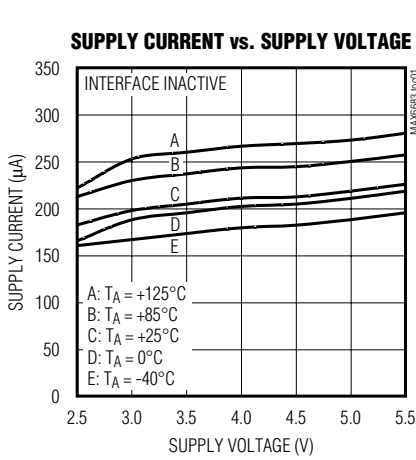

# Temperature Sensor and System Monitor in a 10-Pin $\mu$ MAX

## Pin Description

PIN	NAME	FUNCTION
1	1.8V <sub>IN</sub>	Analog Input. Monitors 1.8V nominal supply.
2	2.5V <sub>IN</sub>	Analog Input. Monitors 2.5V nominal supply.
3	5V <sub>IN</sub>	Analog Input. Monitors 5V nominal supply.
4	N.C.	No Connect. Not internally connected. Connect to GND to improve thermal conductivity.
5	GND	Ground
6	$\overline{\text{ALERT}}$	SMBus Alert (Interrupt) Output, Open Drain. Alerts the master that a temperature or voltage limit has been violated.
7	ADD	SMBus/I <sup>2</sup> C-Compatible Address Select Input. ADD is sampled at the beginning of each SMBus/I <sup>2</sup> C transaction, and the 2LSBs of the Slave Address register are determined by ADD's connection to GND, SDA, SCL, or V <sub>CC</sub> .
8	SDA	SMBus/I <sup>2</sup> C-Compatible Serial Data Interface
9	SCL	SMBus/I <sup>2</sup> C-Compatible Clock Input
10	V <sub>CC</sub>	Supply Voltage Input, +2.7V to +5.5V. Also serves as a voltage monitor input. Bypass V <sub>CC</sub> to GND with a 0.1 $\mu$ F capacitor.

**MAX6683**

### Detailed Description

The MAX6683 is a voltage and temperature monitor designed to communicate through an SMBus/I<sup>2</sup>C interface with an external microcontroller ( $\mu$ C). A  $\mu$ C with no built-in I<sup>2</sup>C or SMBus capabilities can generate SMBus serial commands by “bit-banging” general-purpose input-output (GPIO) pins.

The MAX6683 can monitor external supply voltages of typically 1.8V, 2.5V, 5V, as well as its own supply voltage and temperature. This makes it ideal for supervisor and thermal management applications in telecommunications, desktop and notebook computers, workstations, and networking equipment. Voltage inputs are converted to an 8-bit code and temperature is converted to an 11-bit code. The high-order 8 bits of the temperature conversion can be read using a read byte operation through the I<sup>2</sup>C interface. The full 11-bit temperature conversion is read using a read word operation and disregarding the lower 5 bits of the low byte. By setting bit 5 of the Configuration Register to 1, the temperature conversion can be reduced to 9 bits with a four-fold reduction in conversion time. In this case, the lower 7 bits of the low byte should be disregarded; 8-bit temperature data has a resolution of 1°C/LSB, while 11-bit temperature data has a resolution of 0.125°C/LSB. Setting bit 5 of the Configuration Register to 1 reduces the monitoring cycle time by a factor of 4. In this case, a read word operation for temperature data yields a 9-bit code in which the lower 7 bits of the low byte should be disregarded. The LSB of the 9-bit temperature data has a value of 0.5°C.

Each input voltage is scaled down by an on-chip resistive voltage-divider so that its output, at the nominal input voltage, is 3/4 of the ADC's full-scale range, or a decimal count of 192 (Table 3). Input voltages other than the nominal values may be used; ensure that they fall within the usable ranges of pins to which they are applied. Attenuate voltages greater than 6V with an external resistive voltage-divider.

Writing a 1 to bit 0 of the Configuration Register starts the monitoring function. The device performs a sequential sampling of all the inputs, starting with the internal temperature sensor and continuing with 2.5V<sub>IN</sub>, 1.8V<sub>IN</sub>, 5V<sub>IN</sub>, and V<sub>CC</sub>. If the master terminates the conversion, the sequential sampling does not stop until the sampling cycle is completed and the results are stored. When it starts again, it always starts with the temperature measurement.

An interrupt signal is generated when a temperature measurement goes above the hot limit or when a voltage measurement is either above the high limit or below the low limit. This causes the open-drain output  $\overline{\text{ALERT}}$  to go to the active-low state and set each corresponding interrupt status bit (bits 0 through 4) to 1 (Table 5). The interrupt is cleared by reading the Interrupt Status Register except for temperature interrupts generated in comparator mode. Reading the Interrupt Status Register also clears the register itself, except for temperature interrupt bits set in comparator mode.

# Temperature Sensor and System Monitor in a 10-Pin $\mu$ MAX

Table 1. Register Map

ADDRESS	READ/WRITE	POWER-ON DEFAULT	DESCRIPTION
20h	R	—	Data register for 2.5 V <sub>IN</sub> measurement
21h	R	—	Data register for 1.8V <sub>IN</sub> measurement
22h	R	—	Data register for 5V <sub>IN</sub> measurement
23h	R	—	Data register for V <sub>CC</sub> measurement
27h	R	—	Data register for temperature measurement
2Bh	R/W	1101 0011 (1.1 × 2.5V)	High limit for 2.5V <sub>IN</sub>
2Ch	R/W	1010 1101 (0.9 × 2.5V)	Low limit for 2.5V <sub>IN</sub>
2Dh	R/W	1101 0011 (1.1 × 1.8V)	High limit for 1.8V <sub>IN</sub>
2Eh	R/W	1010 1101 (0.9 × 1.8V)	Low limit for 1.8V <sub>IN</sub>
2Fh	R/W	1101 0011 (1.1 × 5V)	High limit for 5V <sub>IN</sub>
30h	R/W	1010 1101 (0.9 × 5V)	Low limit for 5V <sub>IN</sub>
31h	R/W	1101 0011 (1.1 × 3.3V)	High limit for V <sub>CC</sub>
32h	R/W	1010 1101 (0.9 × 3.3V)	Low limit for V <sub>CC</sub>
39h	R/W	0101 0000 (+80°C)	Hot temperature limit
3Ah	R/W	0100 0001 (+65°C)	Hot temperature hysteresis
40h	R/W	0000 1000	Configuration Register
41h	R	0000 0000	Interrupt Status Register
43h	R/W	0000 0000	Interrupt Mask Register
48h	R/W	0010 1XXY	Device Address Register. The values of XX are dependent on the status of the ADD pin. <b>Power-On Default    ADD Connection</b> 0010 100Y            To GND 0010 101Y            To V <sub>CC</sub> 0010 110Y            To SDA 0010 111Y            To SCL Y (bit 0) is the SMBus read/write bit. When the 7-bit chip address is read back from the Serial Address Register, an 8-bit word is presented with a zero in bit 0 (Y).
4Bh	R/W	0000 0000	Temperature Configuration Register

Unless the fault is removed, the  $\overline{\text{ALERT}}$  output only remains cleared until the end of the next conversion cycle where it is again asserted. The  $\overline{\text{ALERT}}$  output can also be masked by writing to the appropriate bits in the Interrupt Mask Register (Table 6) or by setting bit 1 of the Configuration Register (Table 4) to zero.

The 2-wire serial interface accepts both I<sup>2</sup>C and standard SMBus Write Byte, Read Byte, Read Word, Send Byte, and Receive Byte commands to program the alarm thresholds and to read voltage and temperature data. Voltage data is scaled so that when the nominal voltage is present at an input (e.g., 1.8V for the 1.8V<sub>IN</sub> input), the conversion result is equal to 3/4 of the ADC full-scale range or a decimal count of 192 (Table 1).

When using the Read Byte command, the temperature data format is 7 bits plus sign with the LSB equal to 1°C, in two's complement format. When using the Read Word command, the temperature data format is 10 bits plus sign, with the LSB equal to 0.125°C, in two's complement format. See Table 2 for the temperature data format.

The MAX6683 has only one address input, ADD. Connect ADD to GND, V<sub>CC</sub>, SDA, or SCL to select one of four different address codes. Whenever an SMBus/I<sup>2</sup>C transaction is initiated, the 2LSBs of the Slave Address Register are determined by connection, setting the chip address to one of four possible values. In addition, an address code can also be directly writ-

# Temperature Sensor and System Monitor in a 10-Pin $\mu$ MAX

**Table 2. Temperature Data Format (Two's Complement)**

HIGH BYTE		
TEMPERATURE (°C)	DIGITAL OUTPUT (BINARY)	DIGITAL OUTPUT (HEX)
+125	0111 1101	7D
+25	0001 1001	19
+1	0000 0001	01
0	0000 0000	00
-1	1111 1111	FF
-25	1110 0111	E7
-40	1101 1000	D8
LOW BYTE		
0.875	1110 0000	D0
0.125	0010 0000	20

ten to the Serial Address Register. This code overwrites the code set by connection of the ADD pin, until the MAX6683 is taken through a POR cycle.

### ADC and Multiplexer

The ADC integrates over a 66ms period, an integral multiple of the line period with excellent noise rejection. The internal oscillator is trimmed to produce a 66ms conversion time for temperature and 33ms for each

voltage. This is equivalent to 4 and 2 cycles of 60Hz, respectively, and provides protection against noise pickup from the main supply. The internal oscillator frequency can be changed to provide the same protection against 50Hz by setting bit 7 in the Configuration Register to 1 (Table 4). The multiplexer automatically sequences through the inputs, measuring voltages and temperature.

### Low-Power Shutdown Mode

Setting bit 0 in the Configuration Register to zero stops the monitoring loop and puts the MAX6683 into low-power shutdown mode. In this mode, the SMBus/I<sup>2</sup>C interface remains active, and the supply current drops to 10 $\mu$ A or less.

### Power-On Reset

The MAX6683 POR supply voltage is typically 2V. Below this supply voltage, all registers are reset, the device is put into shutdown mode, and the SMBus/I<sup>2</sup>C interface is inactive.

### Alarm Threshold Registers

Two registers, a hot temperature limit (T<sub>HOT</sub>) at 39h and a hot temperature hysteresis (T<sub>HYST</sub>) at 3Ah, store alarm threshold data (Table 1). If a measured temperature exceeds the value of T<sub>HOT</sub>, an ALERT is asserted. Alerts are cleared and reasserted depending on the interrupt mode selected in the Temperature Configuration Register (see *ALERT Interrupts*).

**Table 3. Voltage Data Format**

ADC OUTPUT CODE	INPUT VOLTAGE AT 1.8V <sub>IN</sub>	INPUT VOLTAGE AT 2.5V <sub>IN</sub>	INPUT VOLTAGE AT 5V <sub>IN</sub>	V <sub>CC</sub> = +3.3V
LSB weight	9.375mV (1.8V/192)	13mV (2.5V/192)	26mV (5V/192)	17.2mV (3.3V/192)
0	< 9.375mV	< 13mV	< 26mV	—
1	9.375mV to 18.75mV	13mV to 26mV	26mV to 52mV	—
2	18.75mV to 28.125mV	26mV to 39mV	52mV to 78mV	—
—	—	—	—	—
64 (1/4 scale)	600mV to 609.4mV	833mV to 846mV	1.664V to 1.692V	—
—	—	—	—	—
128 (1/2 scale)	1.2V to 1.2094V	1.667V to 1.680V	3.330V to 3.560V	—
—	—	—	—	—
192 (3/4 scale)	1.8V to 1.737V	2.5V to 2.513V	5V to 5.026V	3.3V to 3.317V
—	—	—	—	—
253	2.372V to 2.381V	3.294V to 3.307V	6.566V to 6.640V	4.348V to 4.366V
254	2.381V to 2.391V	3.572V to 3.586V	6.615V to 6.640V	4.366V to 4.383V
255	= 2.391V	= 3.586V	= 6.640V	= 4.383V

# Temperature Sensor and System Monitor in a 10-Pin $\mu$ MAX

**Table 4. Configuration Register (Address 40h, Power-On Default = 08h)**

BIT	NAME	READ/WRITE	DESCRIPTION
0	Start/Stop	R/W	This bit controls the monitoring loop. Setting the bit to zero stops the monitoring loop and puts the device into shutdown mode. The I <sup>2</sup> C/SMBus interface is still active during the shutdown mode. Setting the bit to 1 starts the monitoring cycle. All high/low limits should be set before setting this bit to 1.
1	$\overline{\text{ALERT}}$ Enable	R/W	This bit is used to enable or disable the $\overline{\text{ALERT}}$ output. Setting the bit to 1 enables the $\overline{\text{ALERT}}$ output; setting the bit to 0 disables the $\overline{\text{ALERT}}$ output.
2	Reserved	—	—
3	$\overline{\text{ALERT}}$ Clear	R/W	This bit is used to clear the $\overline{\text{ALERT}}$ output when it is set to high. It does not affect the Interrupt Status Register. The monitoring loop does not start until the bit is set to zero.
4	Line Frequency Select	R/W	This bit controls the internal clock frequency. Setting the bit to 1 changes the clock frequency to 51.2kHz from 61.4kHz. This can improve the measurement accuracy when the power-line frequency is at 50Hz.
5	Short Cycle	R/W	This bit reduces the conversion time by a factor of 4 when it is set to 1.
6	Reserved	—	—
7	Reset	R/W	This bit is used as a reset signal for the register initialization. The 1 of this bit resets all the register values into the power-up default mode, including bit 7 itself.

**Table 5. Interrupt Status Register (Address 41h, Power-Up Default = 00h)**

BIT	NAME	READ/WRITE	DESCRIPTION
0	2.5V <sub>IN</sub> -Error	R	A 1 indicates either a high or low limit has been exceeded at the 2.5V <sub>IN</sub> input.
1	1.8V <sub>IN</sub> -Error	R	A 1 indicates either a high or low limit has been exceeded at the 1.8V <sub>IN</sub> input.
2	5V <sub>IN</sub> -Error	R	A 1 indicates either a high or low limit has been exceeded at the 5V <sub>IN</sub> input.
3	V <sub>CC</sub> -Error	R	A 1 indicates either a high or low limit has been exceeded at the V <sub>CC</sub> input.
4	Temp-Error	R	A 1 indicates either a high or low limit has been exceeded at the internal temperature sensor. The conditions that generate and clear this bit depend on the temperature interrupt mode selected by bits 0 and 1 in the Temperature Configuration Register.
5, 6, 7	Reserved	—	—

The POR state of the T<sub>HOT</sub> register is 0101 0000 or +80°C. The POR state of the T<sub>HYST</sub> register is 0100 0001 or +65°C.

High and low limits for the voltage inputs are stored in registers 2Bh through 32h. If a measured voltage is less than V<sub>LOW</sub> or greater than V<sub>HIGH</sub>, an  $\overline{\text{ALERT}}$  is asserted.

The POR states of the high and low voltage limits are 1.1 and 0.9 times the nominal voltage for each input.

### Interrupt Status Byte Functions

The Interrupt Status Register records temperature or voltage fault conditions whenever a limit is exceeded (Table 5). Bits 0 through 3 correspond to the 2.5V, 1.8V, 5V, and V<sub>CC</sub> voltage inputs and bit 4 corresponds to the temperature. If a threshold has been crossed, the appropriate bit contains a 1. In the default and one-time interrupt modes, reading the status register clears the register until a new out-of-range condition is detected.

# Temperature Sensor and System Monitor in a 10-Pin $\mu$ MAX

**Table 6. Interrupt Mask Register (Address 43h, Power-Up Default = 00h)**

BIT	NAME	READ/WRITE	DESCRIPTION
0	2.5V	R/W	Setting the bit to 1 disables the Interrupt Status Register bit (bit 0) and the $\overline{\text{ALERT}}$ output for the 2.5V <sub>IN</sub> input.
1	1.8V	R/W	Setting the bit to 1 disables the Interrupt Status Register bit (bit 1) and the $\overline{\text{ALERT}}$ output for the 1.8V <sub>IN</sub> input.
2	5V	R/W	Setting the bit to 1 disables the Interrupt Status Register bit (bit 2) and the $\overline{\text{ALERT}}$ output for the 5V <sub>IN</sub> input.
3	3.3V	R/W	Setting the bit to 1 disables the Interrupt Status Register bit (bit 3) and the $\overline{\text{ALERT}}$ output for the V <sub>CC</sub> input.
4	Temp.	R/W	Setting the bit to 1 disables the Interrupt Status Register bit (bit 4) and the $\overline{\text{ALERT}}$ output for temperature.
5, 6, 7	Reserved	—	—

**Table 7. Temperature Configuration Register (Address 4Bh, Power-Up Default = 00h)**

BIT	NAME	READ/WRITE	DESCRIPTION
0, 1	Hot Temperature Interrupt Select	R/W	Bit 1, bit 0 = 00: Default mode Bit 1, bit 0 = 01: One-time interrupt mode Bit 1, bit 0 = 10: Comparator mode Bit 1, bit 0 = 11: Default mode
2–7	Reserved	—	—

### **$\overline{\text{ALERT}}$ Interrupts**

An out-of-range voltage or temperature causes the  $\overline{\text{ALERT}}$  output signal to be asserted. However, if the assertion is caused by an out-of-range temperature, the  $\overline{\text{ALERT}}$  output can operate in one of three different modes: default, one-time interrupt, or comparator mode. In the default and one-time interrupt modes, the  $\overline{\text{ALERT}}$  signal and Interrupt Status Register are cleared by reading the Interrupt Status Register (Table 5). In comparator mode,  $\overline{\text{ALERT}}$  is only cleared when the fault condition is removed. Reading the Interrupt Status Register clears all but bit 4 of the Status Register if the fault condition is not removed. Reading the Interrupt Status Register with the fault condition removed clears the entire register. Unless the fault is removed,  $\overline{\text{ALERT}}$  is reasserted after the next conversion cycle. The  $\overline{\text{ALERT}}$  output can also be masked by writing to the appropriate bits in the Interrupt Mask Register (Table 6) or by setting bit 1 of the Configuration Register (Table 4) to zero.

The interrupt does not halt conversions. New temperature and voltage data continue to be available over the SMBus interface after  $\overline{\text{ALERT}}$  is asserted. The three temperature  $\overline{\text{ALERT}}$  modes are shown in Figure 1 and

are selected through the Temperature Configuration Register (Table 7). The  $\overline{\text{ALERT}}$  output pin is open drain, so the device can share a common interrupt line.

#### **Default Mode**

An interrupt is initiated when temperature exceeds T<sub>HOT</sub> (address 39h). The interrupt is cleared only by reading the Interrupt Status Register. An interrupt continues to be generated on subsequent measurements until the temperature goes below T<sub>HYST</sub> (address 3Ah).

#### **One-Time Interrupt Mode**

An interrupt is initiated when temperature exceeds T<sub>HOT</sub> (address 39h). The interrupt is cleared only by reading the Interrupt Status Register. The next interrupt is then initiated when temperature falls below the T<sub>HYST</sub> (address 3Ah).

#### **Comparator Mode**

An interrupt is initiated when temperature exceeds T<sub>HOT</sub> (address 39h). The  $\overline{\text{ALERT}}$  output remains asserted low until the temperature goes below T<sub>HOT</sub>. Reading the Interrupt Status Register does not clear the  $\overline{\text{ALERT}}$  output or interrupt status bit in the register. The interrupt continues to be generated on subsequent measurements until the temperature falls below T<sub>HOT</sub>.

# Temperature Sensor and System Monitor in a 10-Pin $\mu$ MAX

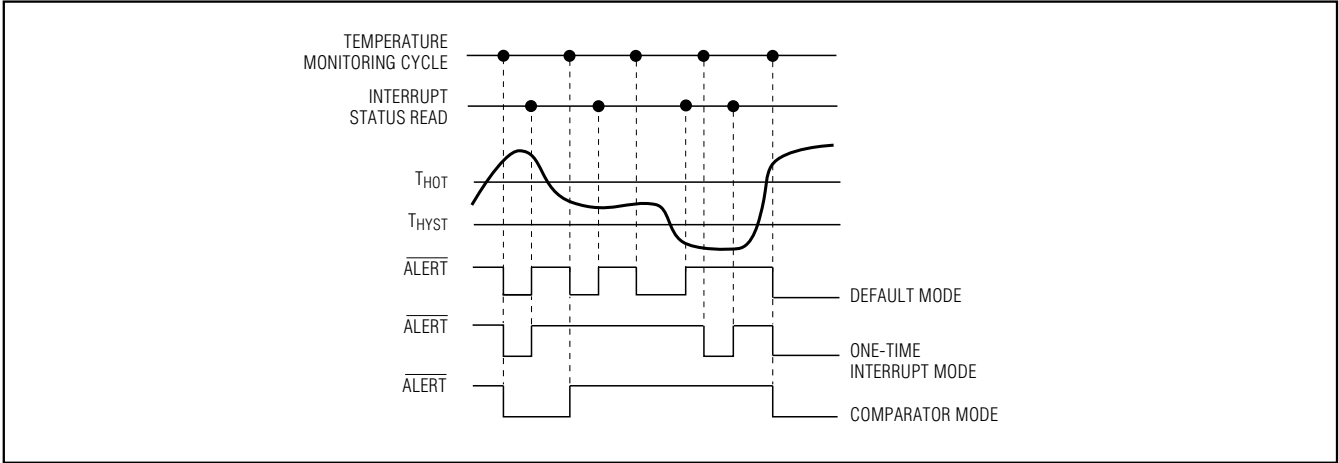

Figure 1. Alert Response to Temperature Interrupts

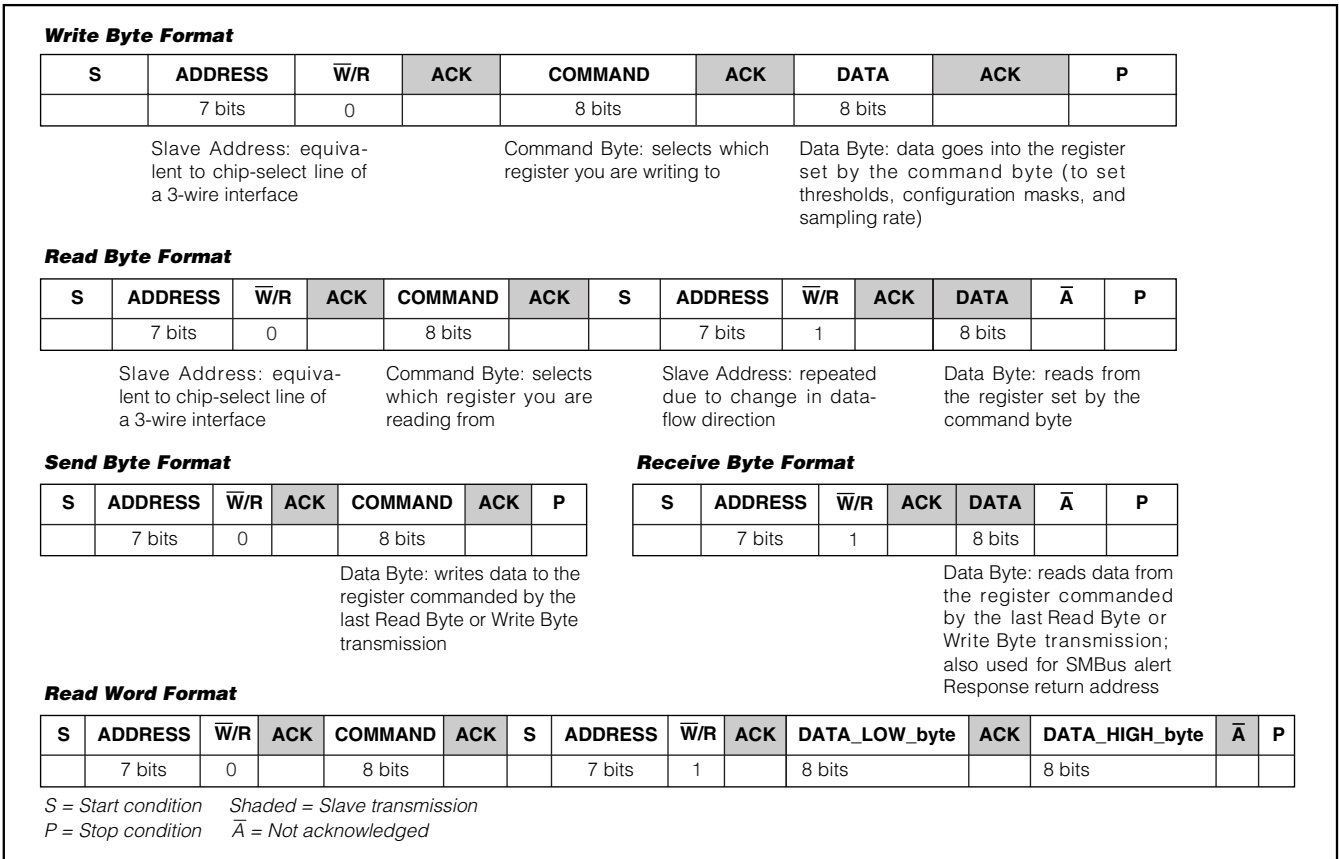

Figure 2. SMBus Protocols

# Temperature Sensor and System Monitor in a 10-Pin $\mu$ MAX

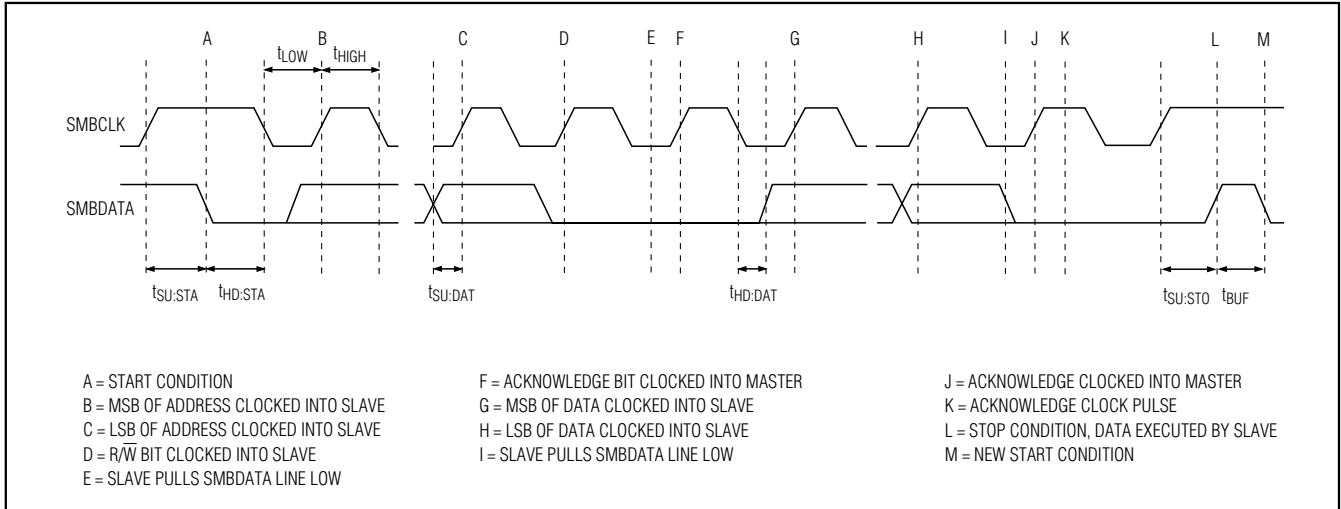

Figure 3. SMBus Write Timing Diagram

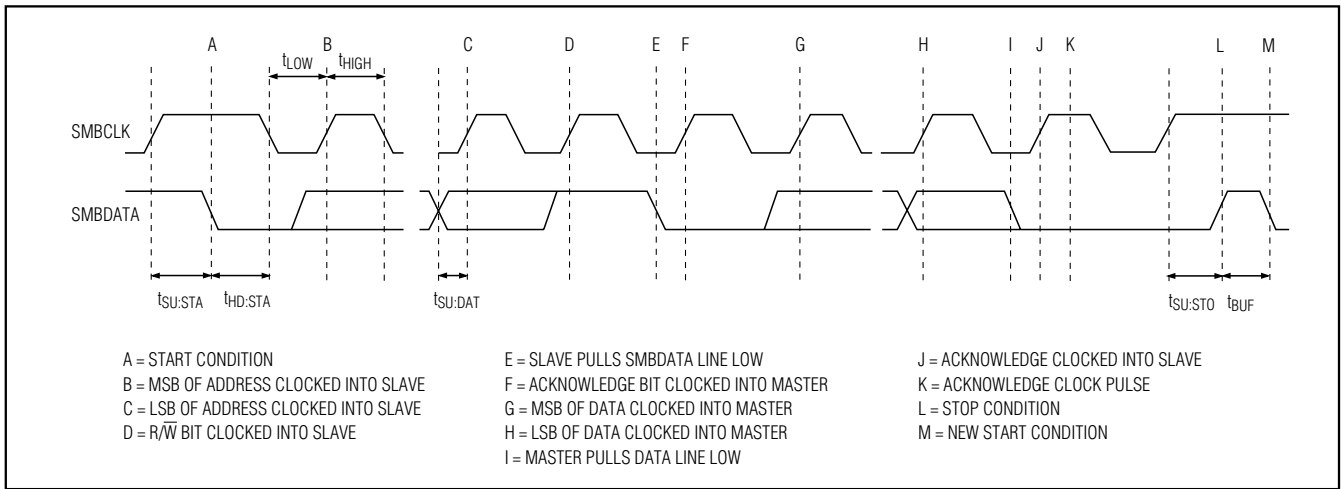

Figure 4. SMBus Read Timing Diagram

### SMBus/I<sup>2</sup>C-Compatible Digital Interface

From a software prospective, the MAX6683 appears as a set of byte-wide registers that contain voltage and temperature data, alarm threshold values, or control bits.

The device employs five standard SMBus protocols: write byte, read byte, read word, send byte, and receive byte (Figures 2, 3, 4).

### Slave Address

The device address can be set to one of four different values by pin strapping ADD to GND, SDA, SCL, or

V<sub>CC</sub>, so more than one MAX6683 can reside on the same bus without address conflicts (Table 1). The address pin state is checked at the beginning of each SMBus/I<sup>2</sup>C transaction and is insensitive to glitches on V<sub>CC</sub>. Any address code can also be written to the Serial Address Register and overwrites the code set by connecting the ADD pin until the MAX6683 is taken through a POR cycle.

The MAX6683 also responds to the SMBus alert response address (see *Alert Response Address*).

# Temperature Sensor and System Monitor in a 10-Pin $\mu$ MAX

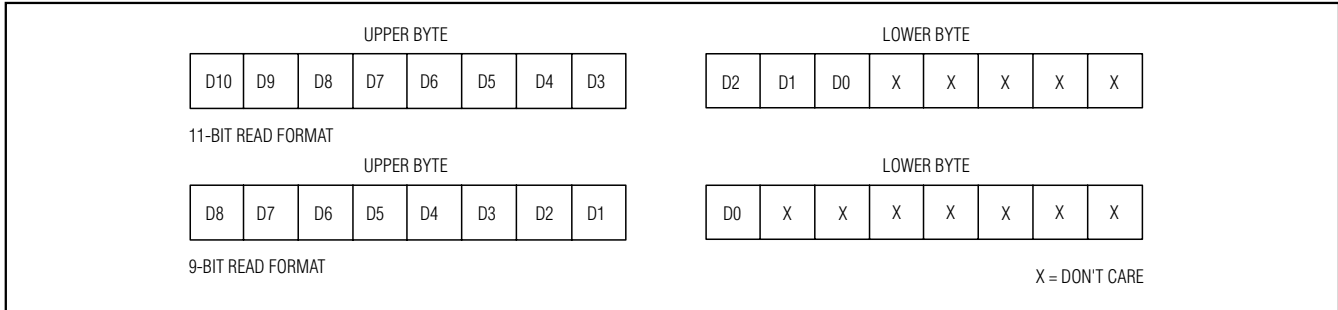

Figure 5. Read Temperature Format

### Alert Response Address

The SMBus alert response interrupt pointer provides quick fault identification for simple slave devices that lack the complex, expensive logic needed to be a bus master. Usually the ALERT outputs of several slave devices are wire-ORed to the same interrupt input of the host master. Upon receiving an interrupt signal, the host master can broadcast a receive byte transmission (Figure 2) with the alert response address (0001 100). A read operation is denoted by a 1 in the eighth address bit. Then, any slave device that generated an interrupt attempts to identify itself by putting its own address on the bus.

The alert response can activate several different slave devices simultaneously, similar to the I<sup>2</sup>C general call. If more than one slave attempts to respond, bus arbitration rules apply, and the device with the lower address code wins. The losing device does not generate an acknowledge signal and continues to hold the interrupt line low until serviced. The MAX6683 does not automatically clear its  $\overline{\text{ALERT}}$  when it responds to an alert response address. The host master must then clear or mask the  $\overline{\text{ALERT}}$  by reading the Interrupt Status Register, writing to the Interrupt Mask Register, or setting bit 1 of the Configuration Register to zero before it can identify other slaves generating an interrupt.

### Command Byte Functions

The 8-bit Command Byte Register (Table 1) is the master index that points to the other data, configuration, limits, and address registers within the MAX6683. The functions of those other registers are described below.

### Configuration Byte Functions

The Configuration Register (Table 4) is a read-write register with several functions:

- Bit 0 puts the MAX6683 into software standby mode (STOP) or autoconvert (START) mode. The 2-wire interface is still active in the standby mode. All voltage and temperature limits should be set before setting this bit to 1.
- Bit 1 enables and disables the  $\overline{\text{ALERT}}$  output. Setting this bit to 1 enables the ALERT output.
- Bit 2 is reserved.
- Bit 3 clears the  $\overline{\text{ALERT}}$  output and stops the monitoring loop when set to 1. Clearing the output does not affect the contents of the Interrupt Status Registers.
- Bit 4 sets the analog-to-digital conversion speed to minimize interference from power-line frequencies. Setting this bit to 1 can improve accuracy when the power-line frequency is 50Hz. When the power-line frequency is 60Hz, bit 4 should be zero.
- Bit 5 reduces the oversampling ratio in the ADC from 8 to 2. This reduces the monitoring cycle time by a factor of 4 to typically 50ms at the cost of reduced noise rejection.
- Bit 6 is reserved.
- Bit 7 resets all register values to their power-up default values. To reset all registers, set bit 7 to 1. This also resets bit 7 to its power-up value of zero.

### Read Temperature

The MAX6683 reads out temperature in an 8-, 9-, or 11-bit two's complement format. To obtain the 8-bit temperature data (7 bits plus sign), execute a Read Byte command to the Temperature Data Register (address 27h).

To obtain the 11-bit temperature data (10 bits plus sign), execute a Read Word command to the Temperature Data Register (address 27h). When per-

# Temperature Sensor and System Monitor in a 10-Pin $\mu$ MAX

MAX6683

## Functional Diagram

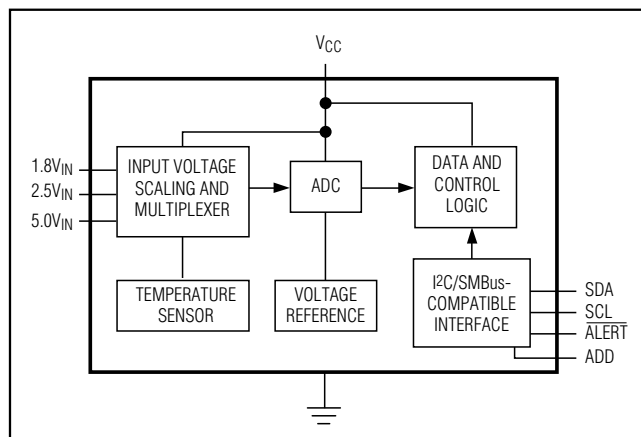

forming a Read Word operation, the MAX6683 writes the 11 bits of data to the bus in two 8-bit words. The upper byte contains the MSBs, while the lower byte contains the 3LSBs (Figure 5). D9–D3 of the upper byte represent the whole decimal number of the temperature conversion and D10 is sign. D2–D0 of the lower byte represent 1/2, 1/4, 1/8 of a degree, respectively, and the remaining bits are disregarded.

Nine-bit temperature data (8 bits plus sign) is obtained by setting bit 5 of the Configuration Register (address 40h) to 1, reducing the conversion time by a factor of four, and executing a Read Word command to the Temperature Data Register (address 27h). The upper byte contains the MSBs, while the lower byte contains the LSB (Figure 5). D7–D1 of the upper byte represent the whole decimal number of the temperature conversion and D0 is sign. D0 of the lower byte represents 1/2 of a degree, and the remaining bits are disregarded.

## Applications Information

### Sensing Circuit Board and Component Temperatures

Temperature sensor ICs like the MAX6683 that sense their own die temperatures must be mounted on or close to the object whose temperature they are intended to measure. Because there is a good thermal path between the 10-pin  $\mu$ MAX package's metal leads and the IC die, the MAX6683 can accurately measure the temperature of the circuit board to which it is soldered. If the sensor is intended to measure the temperature of a heat-generating component on the circuit board, it should be mounted as close as possible to that component and should share supply and ground traces (if they are not noisy) with that component where possible. This maximizes the heat transfer from the component to the sensor.

The thermal path between the plastic package and the die is not as good as the path through the leads, so the MAX6683, like all temperature sensors in plastic packages, is less sensitive to the temperature of the surrounding air than to the temperature of the leads.

Wiring and circuits must be kept insulated and dry to avoid leakage and corrosion, especially if they operate at cold temperatures where condensation can occur.

## Chip Information

TRANSISTOR COUNT: 13,446

PROCESS: BiCMOS

# Temperature Sensor and System Monitor in a 10-Pin $\mu$ MAX

## Package Information

(The package drawing(s) in this data sheet may not reflect the most current specifications. For the latest package outline information go to [www.maxim-ic.com/packages](http://www.maxim-ic.com/packages).)

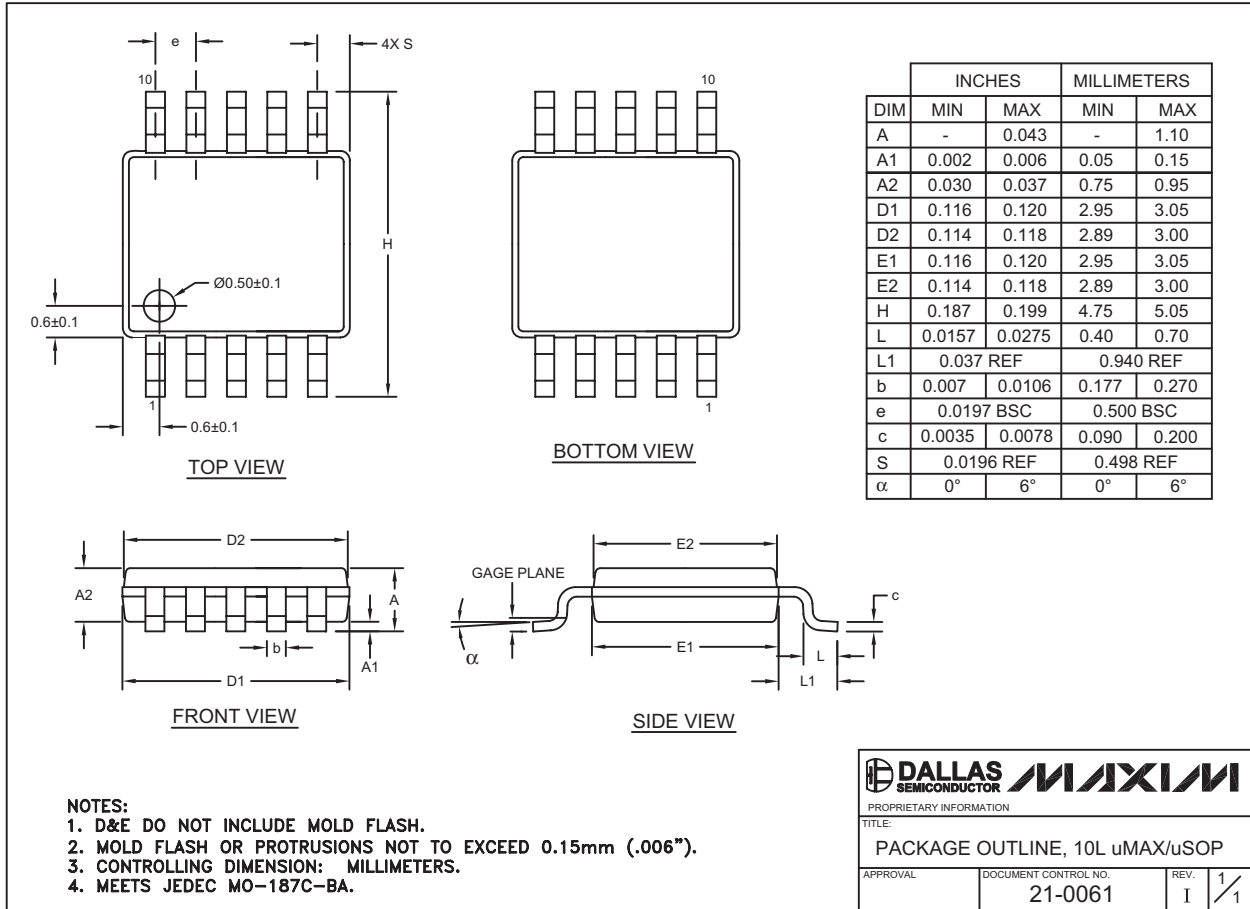

10LUMAX.EPS

Maxim cannot assume responsibility for use of any circuitry other than circuitry entirely embodied in a Maxim product. No circuit patent licenses are implied. Maxim reserves the right to change the circuitry and specifications without notice at any time.

## Looking for pricing, stock, or lifecycle information?

Click below to explore more details on WIN SOURCE:

 [View MAX6683AUB+T on WIN SOURCE](#)

 [Maxim Integrated Information](#)

## Optimize Your Supply Chain with WIN SOURCE Solutions

-  Global Sourcing Solution
-  Obsolete Management
-  Cost Control Management
-  Shortage Management
-  Alternative Solution
-  Excess Inventory Management