



**THE DATASHEET OF
MAX6660AEE+**





Remote-Junction Temperature-Controlled Fan-Speed Regulator with SMBus Interface

MAX6660

General Description

The MAX6660 is a remote temperature sensor and fan-speed regulator that provides a complete fan-control solution. The remote temperature sensor is typically a common-collector PNP, such as a substrate PNP of a microprocessor, or a diode-connected transistor, typically a low-cost, easily mounted 2N3904 NPN type or 2N3906 PNP type.

The device also incorporates a closed-loop fan controller that regulates fan speed with tachometer feedback. The MAX6660 compares temperature data to a fan threshold temperature and gain setting, both programmed over the SMBus™ by the user. The result is automatic fan control that is proportional to the remote-junction temperature. The temperature feedback loop can be broken at any time for system control over the speed of the fan.

Fan speed is voltage controlled as opposed to PWM controlled, greatly reducing acoustic noise and maximizing fan reliability. An on-chip power device drives fans rated up to 250mA.

Temperature data is updated every 0.25s and is readable at any time over the SMBus interface. The MAX6660 is accurate to 1°C (max) when the remote junction is between +60°C to +100°C. Data is formatted as a 10-bit + sign word with 0.125°C resolution.

The MAX6660 is specified for -40°C to +125°C and is available in a 16-pin QSOP package.

Applications

PC
Notebooks
Telecom Systems
Industrial Control Systems
Servers
Workstations

SMBus is a trademark of Intel Corp.

Pin Configuration appears at end of data sheet.

Features

- ◆ Integrated Thermal Sensing and Fan-Regulation Solution
- ◆ Programmable Fan Threshold Temperature
- ◆ Programmable Temperature Range for Full-Scale Fan Speed
- ◆ Accurate Closed-Loop Fan-Speed Regulation
- ◆ On-Chip Power Device Drives Fans Rated Up to 250mA
- ◆ Programmable Under/Overtemperature Alarms
- ◆ SMBus 2-Wire Serial Interface with Timeout (Cannot “Lock Up” the SMBus)
- ◆ Supports SMBus Alert Response
- ◆ ACPI Compatible, Including OVERT System Shutdown Function
- ◆ ±1°C (+60°C to +100°C) Thermal-Sensing Accuracy
- ◆ MAX6660EVKIT Available

Ordering Information

PART	TEMP RANGE	PIN-PACKAGE	PKG CODE
MAX6660AEE	-40°C to +125°C	16 QSOP	E16-5

Typical Operating Circuit

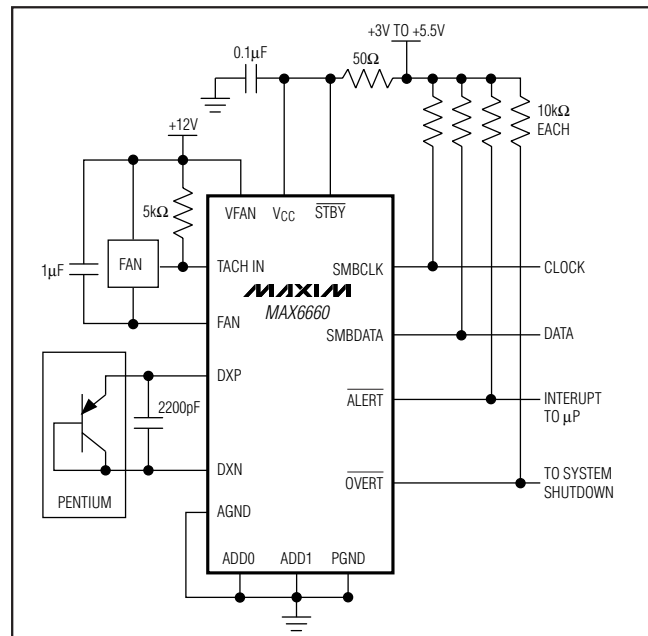

Remote-Junction Temperature-Controlled Fan-Speed Regulator with SMBus Interface

ABSOLUTE MAXIMUM RATINGS

(All voltages referenced to GND.)

V _{CC} , ADD0, ADD1, SMBDATA, SMBCLK, ALERT, OVERT	-0.3V to +6V
V _{FAN} , TACH IN, FAN	-0.3V to +16V
DXP, GAIN	-0.3V to (V _{CC} + 0.3V)
DXN	-0.3V to 1V
SMBDATA, ALERT, OVERT Current	-1mA to +50mA
DXN Current	±1mA

FAN Out Current	500mA
ESD Protection (Human Body Model)	2000V
Continuous Power Dissipation (T _A = +70°C)	16-Pin QSOP (derate 8.3mW/°C above +70°C).....667mW
Operating Temperature Range	-40°C to +125°C
Junction Temperature	+150°C
Storage Temperature Range	-65°C to +150°C
Lead Temperature (soldering, 10s)	+300°C

Stresses beyond those listed under "Absolute Maximum Ratings" may cause permanent damage to the device. These are stress ratings only, and functional operation of the device at these or any other conditions beyond those indicated in the operational sections of the specifications is not implied. Exposure to absolute maximum rating conditions for extended periods may affect device reliability.

ELECTRICAL CHARACTERISTICS

(V_{CC} = +3V to +5.5V, V_{FAN} = +12V, T_A = -40°C to +125°C, unless otherwise specified. Typical values are at V_{CC} = +3.3V and T_A = +25°C.) (Note 1)

PARAMETER	SYMBOL	CONDITIONS	MIN	TYP	MAX	UNITS	
ADC AND POWER SUPPLY							
V _{CC} Supply Voltage	V _{CC}		3.0		5.5	V	
V _{FAN} Supply Voltage	V _{FAN}		4.5		13.5	V	
Operating Supply Current	I _{CC}	Fan off		250	500	μA	
Shutdown Supply Current	I _{SHDN}	Shutdown		3	10	μA	
Temperature Resolution			0.125			°C	
			11			Bits	
Temperature Error (Note 2)	T _E	T _A = +85°C, V _{CC} = +3.3V	T _{RJ} = +60°C to +100°C		-1	+1	°C
			T _{RJ} = +25°C to +125°C		-3	+3	
			T _{RJ} = -40°C to +125°C		-5	+5	
Internal Reference Frequency Accuracy			+25		-25	%	
Temperature Conversion Time				0.25		s	
Conversion Rate Timing Error			-25		+25	%	
Undervoltage Lockout Threshold	V _{UVLO}	V _{CC} falling	2.50	2.80	3.00	V	
Undervoltage Lockout Threshold Hysteresis	V _{HYST}			90		mV	
Power-On-Reset (POR) Threshold (V _{CC})		V _{CC} rising	1.4	2.0	2.5	V	
POR Threshold Hysteresis				90		mV	
Remote-Junction Source Current	I _{RJ}	High level	80	100	120	μA	
		Low level	8	10	12		
DXN Source Voltage	V _{DXN}			0.7		V	

Remote-Junction Temperature-Controlled Fan-Speed Regulator with SMBus Interface

MAX6660

ELECTRICAL CHARACTERISTICS (continued)

($V_{CC} = +3V$ to $+5.5V$, $V_{FAN} = +12V$, $T_A = -40^{\circ}C$ to $+125^{\circ}C$, unless otherwise specified. Typical values are at $V_{CC} = +3.3V$ and $T_A = +25^{\circ}C$.) (Note 1)

PARAMETER	SYMBOL	CONDITIONS	MIN	TYP	MAX	UNITS
Tach Input Transition Level		$V_{FAN} = 12V$		10.5		V
Tach Input Hysteresis		$V_{FAN} = 12V$		190		mV
Current-Sense Tach Threshold				20		mA
Current-Sense Tach Hysteresis				0.3		mA
Fan Output Current			250			mA
Fan Output Current Limit (Note 3)				320	410	mA
Fan Output On-Resistance	R_{ONF}	250mA load		4		Ω
SMBus INTERFACE: SMBDATA, ALERT, STBY, OVERT						
Logic Input Low Voltage	V_{IL}	$V_{CC} = +3.0V$ to $+5.5V$			0.8	V
Logic Input High Voltage	V_{IH}	$V_{CC} = +3.0V$	2.2			V
		$V_{CC} = +5.5V$	2.6			
Input Leakage Current	I_{leak}	$V_{IN} = GND$ or V_{CC}	-2		+2	μA
Output Low Sink Current	I_{OL}	$V_{OL} = 0.4V$	6			mA
Input Capacitance	C_{in}			5		pF
Output High Leakage Current		$V_{OH} = 5.5V$			1	μA
Serial Clock Frequency	f_{SCL}	(Note 4)	0		100	kHz
Bus Free Time Between Stop and Start Conditions	t_{BUF}		4.7			μs
Start Condition Setup Time			4.7			μs
Repeat Start Condition Setup Time	$t_{SU:STA}$	90% to 90%	50			μs
Start Condition Hold Time	$t_{HD:STA}$	10% of SMBDATA to 90% of SMBCLK	4			μs
Stop Condition Setup Time	$t_{SU:STO}$	90% of SMBCLK to 10% of SMBDATA	4			μs
Clock Low Time	t_{LOW}	10% to 10%	4.7			μs
Clock High Time	t_{HIGH}	90% to 90%	4			μs
Data Setup Time	$t_{SU:DAT}$	90% of SMBDATA to 10% of SMBCLK	250			ns
Data Hold Time	$t_{HD:DAT}$	(Note 5)	0			μs
Receive SMBCLK/SMBDATA Rise Time	t_R				1	μs
Receive SMBCLK/SMBDATA Fall Time	t_F				300	ns
SMBus Timeout	$t_{TIMEOUT}$	SMBDATA and SMBCLK time low for reset of serial interface	25		40	ms

Note 1: Junction Temperature = T_A . This implies zero dissipation in pass transistor (no load, or fan turned off).

Note 2: T_{RJ} , Remote Temperature accuracy is guaranteed by design, not production tested.

Note 3: Guaranteed by design. Not production tested.

Note 4: The MAX6660 includes an SMBus timeout, which resets the interface whenever SMBCLK or SMBDATA has been low for greater than 25ms. This feature can be disabled by setting bit 2 of the Fan Gain register at 16h/1Bh to a 1. When the timeout is disabled, the minimum clock frequency is DC.

Note 5: Note that a transition must internally provide at least a hold time in order to bridge the undefined region (300ns max) of SMBCLK's falling edge.

Remote-Junction Temperature-Controlled Fan-Speed Regulator with SMBus Interface

Typical Operating Characteristics

($V_{CC} = +3.3V$, $T_A = +25^{\circ}C$, unless otherwise noted.)

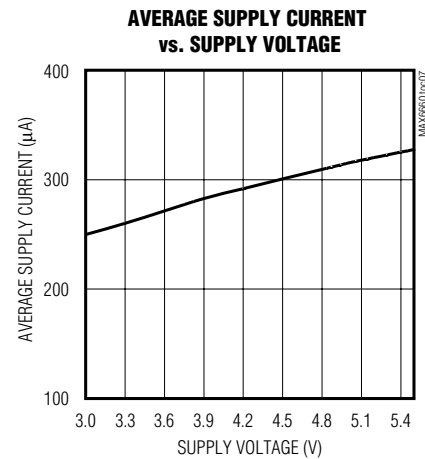
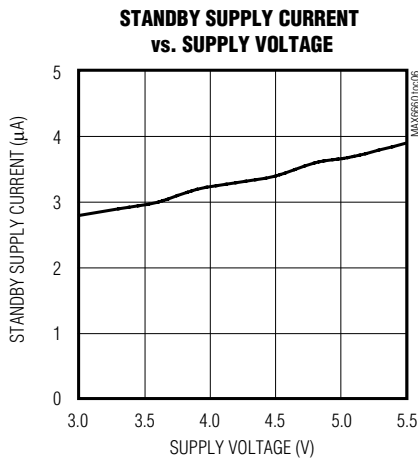
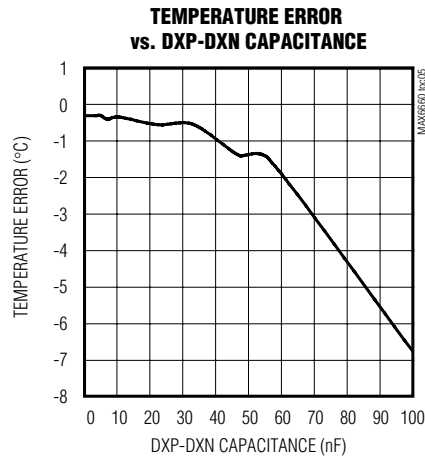
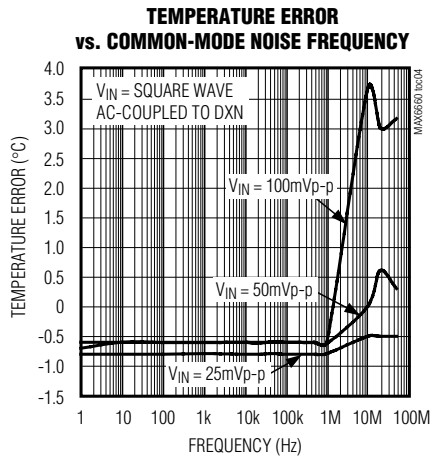
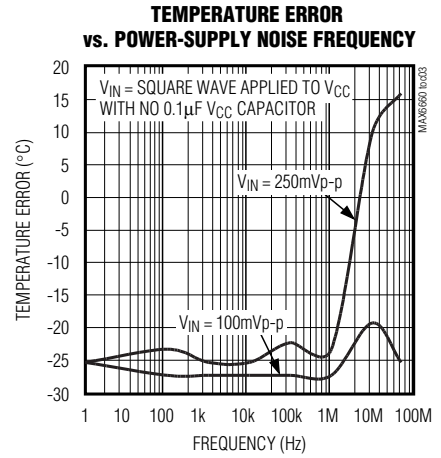
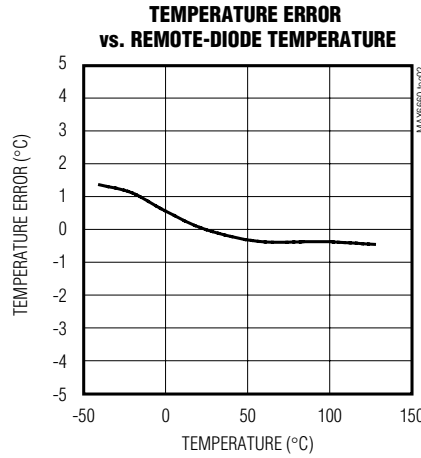
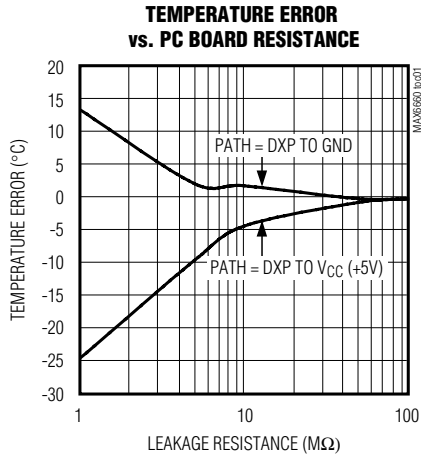

Remote-Junction Temperature-Controlled Fan-Speed Regulator with SMBus Interface

MAX6660

Pin Description

PIN	NAME	FUNCTION
1	VFAN	Fan Drive Power-Supply Input. 4.5V to 13.5V.
2	V _{CC}	Supply Voltage Input. +3V to +5.5V. Bypass V _{CC} to ground with a 0.1μF capacitor.
3	DXP	Input: Remote-Junction Anode. Place a 2200pF capacitor between DXP and DXN for noise filtering.
4	DXN	Input: Remote-Junction Cathode. DXN is internally biased to a diode voltage above ground.
5	FAN	Open-Drain Output to Fan Low Side. Connect a minimum 1μF capacitor between FAN and VFAN.
6	ADD1	SMBus Address Select Pin. ADD0 and ADD1 are sampled upon power-up.
7	PGND	Power Ground
8	AGND	Analog Ground
9	$\overline{\text{OVERT}}$	Overtemperature Shutdown Output. Active-low output (programmable for active high if desired). Open drain.
10	ADD0	SMBus Slave Address Select Pin. ADD0 and ADD1 are sampled upon power-up.
11	$\overline{\text{ALERT}}$	SMBus Alert (Interrupt) Output. Open-drain, active-low output.
12	SMBDATA	SMBus Serial Data Input/Output. Open drain.
13	GAIN	Gain Control. Connect an external resistor from GAIN to V _{CC} to reduce the gain of the current-sense mode.
14	SMBCLK	SMBus Clock Line from Controller. This line tolerates inputs up to V _{CC} even if MAX6660 is not powered.
15	$\overline{\text{STBY}}$	Hardware Standby Input. Drive $\overline{\text{STBY}}$ low to reduce supply current. Temperature and comparison data are retained in standby mode.
16	TACH IN	Fan Tachometer Input. Tolerates voltages up to VFAN.

Detailed Description

The MAX6660 is a remote temperature sensor and fan controller with an SMBus interface. The MAX6660 converts the temperature of a remote-junction temperature sensor to a 10-bit + sign digital word. The remote temperature sensor can be a diode-connected transistor, such as a 2N3906, or the type normally found on the substrate of many processors' ICs. The temperature information is provided to the fan-speed regulator and is read over the SMBus interface. The temperature data, through the SMBus, can be read as a 10-bit + sign two's complement word with a 0.125°C resolution (LSB) and is updated every 0.25s.

The MAX6660 incorporates a closed-loop fan controller that regulates fan speed with tachometer feedback. The temperature information is compared to a threshold and range setting, which enables the MAX6660 to automatically set fan speed proportional to temperature. Full control of these modes is available, including being able to open either the thermal control loop or the fan control loop. Figure 1 shows a simplified block diagram.

ADC

The ADC is an averaging type that integrates over a 60ms period with excellent noise rejection. A bias cur-

rent is steered through the remote diode, where the forward voltage is measured, and the temperature is computed. The DXN pin is the cathode of the remote diode and is biased at 0.65V above ground by an internal diode to set up the ADC inputs for a differential measurement. The worst-case DXP-DXN differential input voltage range is 0.25V to 0.95V. Excess resistance in series with the remote diode causes about +1/2°C error per ohm. Likewise, 200mV of offset voltage forced on DXP-DXN causes approximately 1°C error.

A/D Conversion Sequence

A conversion sequence is initiated every 250ms in the free-running autoconvert mode (bit 6 = 0 in the Configuration register) or immediately by writing a One-Shot command. The result of the new measurement is available after the end of conversion. The results of the previous conversion sequence are still available when the ADC is converting.

Remote-Diode Selection

Temperature accuracy depends on having a good-quality, diode-connected small-signal transistor. Accuracy has been experimentally verified for all devices listed in Table 1. The MAX6660 can also direct-

Remote-Junction Temperature-Controlled Fan-Speed Regulator with SMBus Interface

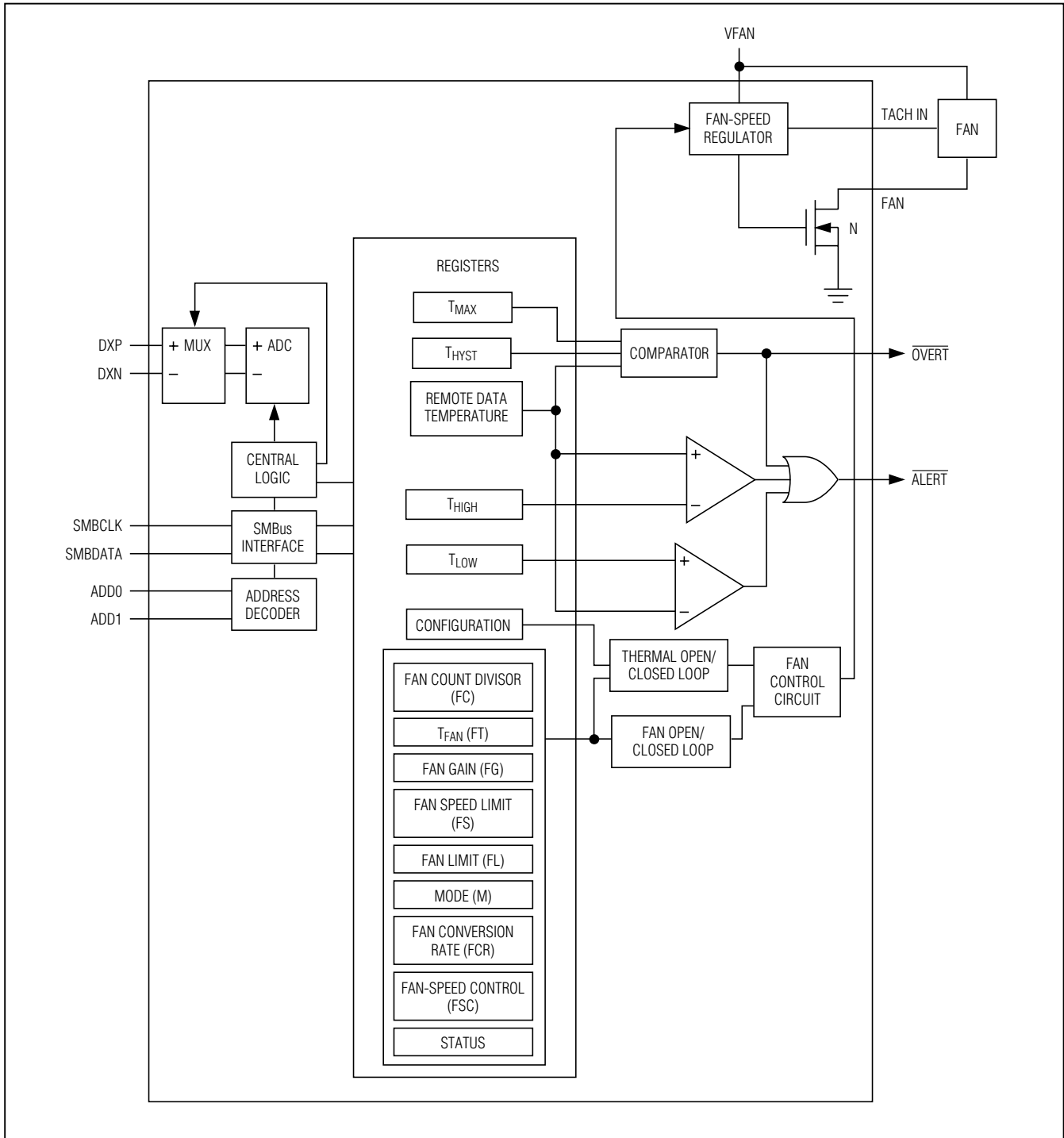

Figure 1. MAX6660 Block Diagram

Remote-Junction Temperature-Controlled Fan-Speed Regulator with SMBus Interface

MAX6660

ly measure the die temperature of CPUs and other ICs that have on-board temperature-sensing diodes.

The transistor must be a small-signal type with a relatively high forward voltage. Otherwise, the A/D input range could be violated. The forward voltage must be greater than 0.25V at 10 μ A. Check to ensure this is true at the highest expected temperature. The forward voltage must be less than 0.95V at 100 μ A. Check to ensure that this is true at the lowest expected temperature. Large power transistors, power diodes, or small-signal diodes must not be used. Also, ensure that the base resistance is less than 100 Ω . Tight specifications for forward current gain ($50 < \beta < 150$, for example) indicate that the manufacturer has good process controls and that the devices have consistent VBE characteristics. Bits 5–2 of the Mode register can be used to adjust the ADC gain to achieve accurate temperature measurements with diodes not included in the recommended list or to individually calibrate the MAX6660 for use in specific control systems.

Thermal Mass and Self-Heating

When measuring the temperature of a CPU or other IC with an on-chip sense junction, thermal mass has virtually no effect; the measured temperature of the junction tracks the actual temperature within a conversion cycle. When measuring temperature with discrete remote sensors, smaller packages (e.g., a SOT23) yield the best thermal response times. Take care to account for thermal gradients between the heat source and the sensor, and ensure that stray air currents across the sensor package do not interfere with measurement accuracy. Self-heating does not significantly affect measurement accuracy. Remote-sensor self-heating due to the diode current source is negligible.

ADC Noise Filtering

The ADC is an integrating type with inherently good noise rejection, especially of low-frequency signals such as 60Hz/120Hz power-supply hum. Micropower operation places constraints on high-frequency noise rejection; therefore, careful PC board layout and proper external noise filtering are required for high-accuracy remote measurements in electrically noisy environments.

High-frequency EMI is best filtered at DXP and DXN with an external 2200pF capacitor. This value can be increased to about 3300pF (max), including cable capacitance. Capacitance higher than 3300pF introduces errors due to rise time of the switched current source. Nearly all noise sources tested cause the ADC measurements to be higher than the actual temperature, typically by +1 $^{\circ}$ C to +10 $^{\circ}$ C, depending on the frequency and amplitude.

Table 1. Remote-Sensor Transistor

MANUFACTURER	MODEL NO.
Central Semiconductor (USA)	2N3904, 2N3906
Fairchild Semiconductor (USA)	2N3904, 2N3906
Rohm Semiconductor (Japan)	SST3904
Samsung (Korea)	KST3904-TF
Siemens (Germany)	SMBT3904
Zetex (England)	FMMT3904CT-ND

Note: Transistors must be diode connected (base shorted to collector).

PC Board Layout

Follow these guidelines to reduce the measurement error of the temperature sensors:

- 1) Place the MAX6660 as close as is practical to the remote diode. In noisy environments, such as a computer motherboard, this distance can be 4in to 8in (typ). This length can be increased if the worst noise sources are avoided. Noise sources include CRTs, clock generators, memory buses, and ISA/PCI buses.
- 2) Do not route the DXP-DXN lines next to the deflection coils of a CRT. Also, do not route the traces across fast digital signals, which can easily introduce +30 $^{\circ}$ C error, even with good filtering.
- 3) Route the DXP and DXN traces in parallel and in close proximity to each other, away from any higher voltage traces, such as +12VDC. Leakage currents from PC board contamination must be dealt with carefully since a 20M Ω leakage path from DXP to ground causes about +1 $^{\circ}$ C error. If high-voltage traces are unavoidable, connect guard traces to GND on either side of the DXP-DXN traces (Figure 2).
- 4) Route through as few vias and crossunders as possible to minimize copper/solder thermocouple effects.
- 5) When introducing a thermocouple, make sure that both the DXP and the DXN paths have matching thermocouples. A copper-solder thermocouple exhibits 3 μ V/ $^{\circ}$ C, and it takes about 200 μ V of voltage error at DXP-DXN to cause a +1 $^{\circ}$ C measurement error. Adding a few thermocouples causes a negligible error.
- 6) Use wide traces. Narrow traces are more inductive and tend to pick up radiated noise. The 10mil widths and spacings that are recommended in Figure 2 are not absolutely necessary, as they offer only a minor

Remote-Junction Temperature-Controlled Fan-Speed Regulator with SMBus Interface

improvement in leakage and noise over narrow traces. Use wider traces when practical.

- 7) Add a 50Ω resistor in series with VCC for best noise filtering (see *Typical Operating Circuit*).

PC Board Layout Checklist

- Place the MAX6660 close to the remote-sense junction.
- Keep traces away from high voltages (+12V bus).
- Keep traces away from fast data buses and CRTs.
- Use recommended trace widths and spacings.
- Place a ground plane under the traces.
- Use guard traces flanking DXP and DXN and connecting to GND.
- Place the noise filter and the 0.1μF VCC bypass capacitors close to the MAX6660.

Twisted-Pair and Shielded Cables

Use a twisted-pair cable to connect the remote sensor for remote-sensor distances longer than 8in or in very noisy environments. Twisted-pair cable lengths can be between 6ft and 12ft before noise introduces excessive errors. For longer distances, the best solution is a shielded twisted pair like that used for audio microphones. For example, Belden #8451 works well for distances up to 100ft in a noisy environment. At the device, connect the twisted pair to DXP and DXN and the shield to GND. Leave the shield unconnected at the remote sensor.

For very long cable runs, the cable's parasitic capacitance often provides noise filtering, so the 2200pF capacitor can often be removed or reduced in value. Cable resistance also affects remote-sensor accuracy. For every 1Ω of series resistance, the error is approximately +1/2°C.

Low-Power Standby Mode

Standby mode reduces the supply current to less than 10μA by disabling the ADC, the control loop, and the fan driver. Enter hardware standby mode by forcing \overline{STBY} low, or enter software standby by setting the RUN/STOP bit to 1 in the Configuration Byte register. Hardware and software standbys are very similar; all data is retained in memory, and the SMB interface is alive and listening for SMBus commands. The only difference is that in software standby mode, the one-shot command initiates a conversion. With hardware standby, the one-shot command is ignored. Activity on the SMBus causes the device to draw extra supply current.

Driving \overline{STBY} low overrides any software conversion command. If a hardware or software standby command

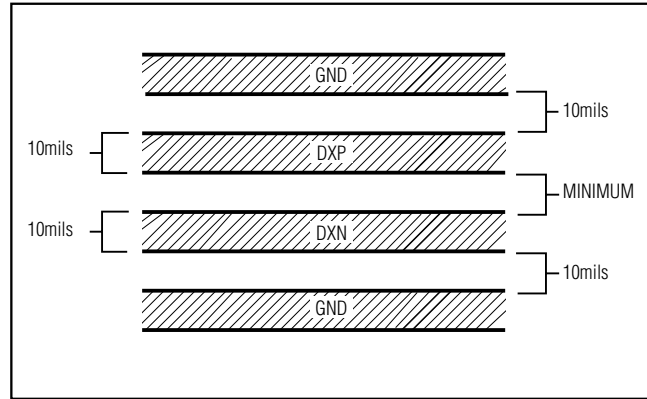

Figure 2. Recommended DXP-DXN PC Trace

is received while a conversion is in progress, the conversion cycle is interrupted, and the temperature registers are not updated. The previous data is not changed and remains available.

SMBus Digital Interface

From a software perspective, the MAX6660 appears as a set of byte-wide registers that contain temperature data, alarm threshold values, and control bits. The device responds to the same SMBus slave address for access to all functions.

The MAX6660 employs four standard SMBus protocols: Write Byte, Read Byte, Send Byte, and Receive Byte (Figures 3, 4, 5) to program the alarm thresholds, read the temperature data, and read and write to all fan control loop registers. The shorter Receive Byte protocol allows quicker transfers, provided that the correct data register was previously selected by a Read Byte instruction. Use caution with the shorter protocols in multimaster systems, since a second master could overwrite the command byte without informing the first master.

Table 2. Temperature Data Format (Two's Complement)

TEMP (°C)	DIGITAL OUTPUT
+127	0111 1111 111
+125.00	0111 1101 000
+25	0001 1001 000
+0.125	0000 0000 001
0	0000 0000 000
-0.125	1111 1111 111
-25	1110 0111 111
-40	1101 1000111

Remote-Junction Temperature-Controlled Fan-Speed Regulator with SMBus Interface

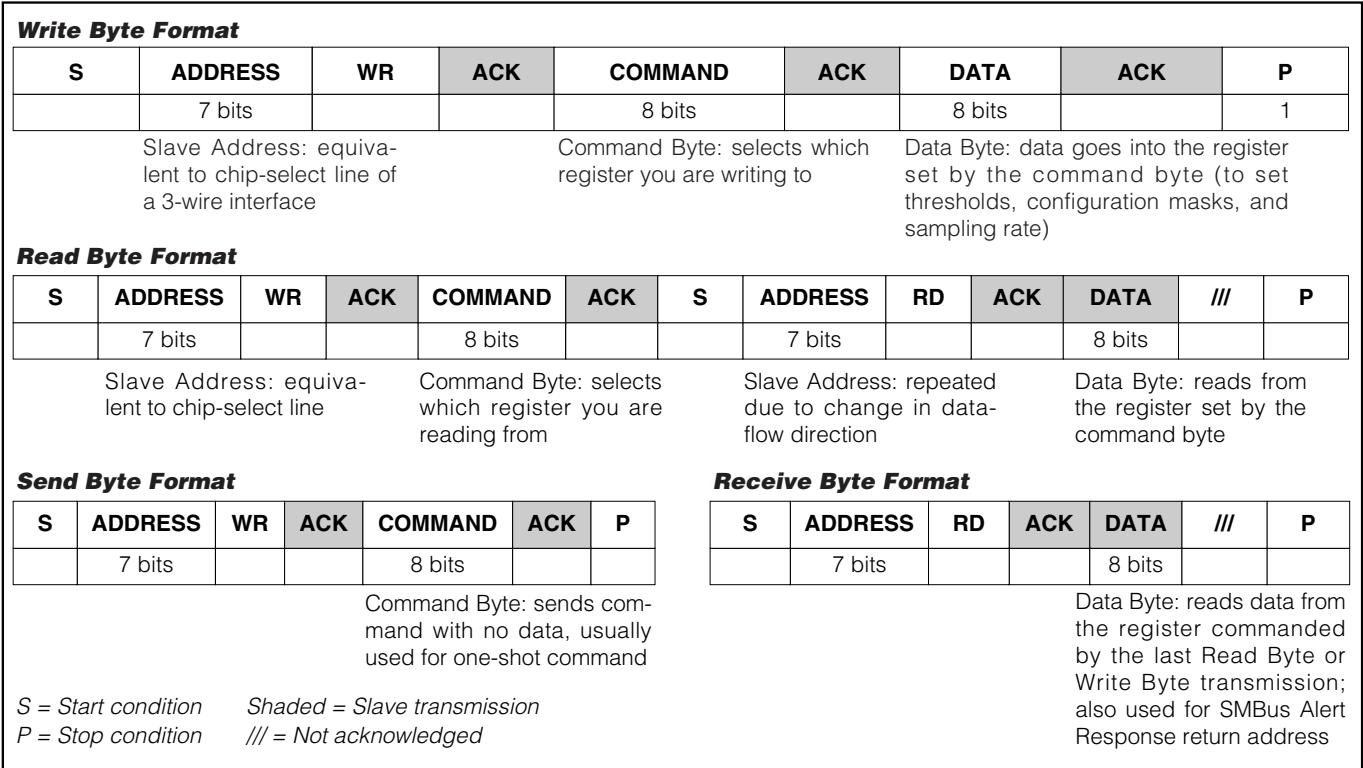

Figure 3. SMBus Protocols

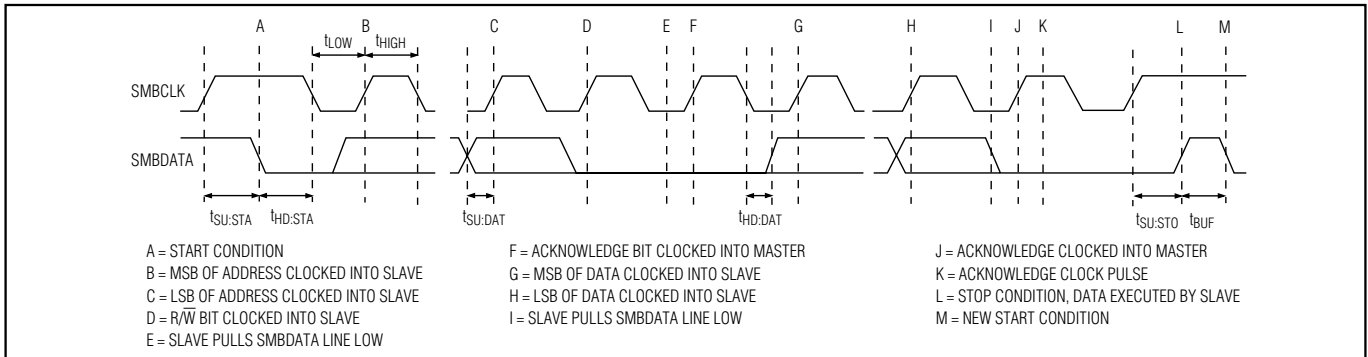

Figure 4. SMBus Write Timing Diagram

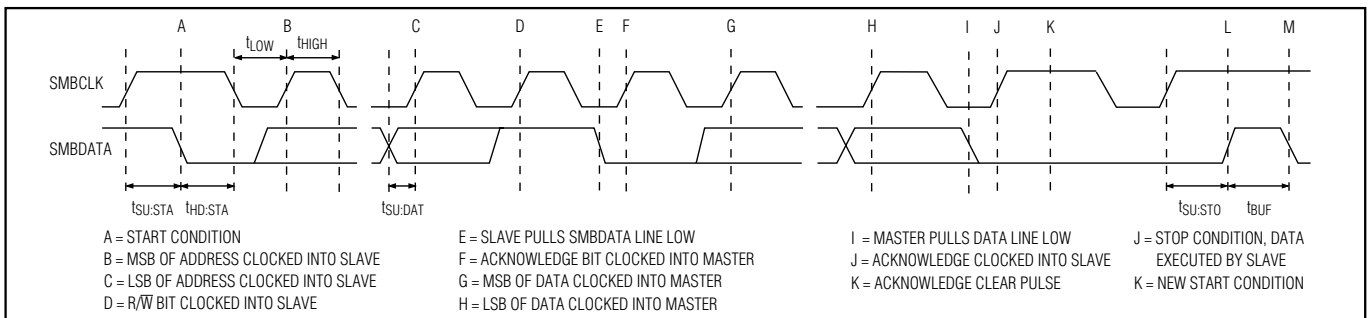

Figure 5. SMBus Read Timing Diagram

Remote-Junction Temperature-Controlled Fan-Speed Regulator with SMBus Interface

The SMBus interface includes a Timeout, which resets the interface any time the data or clock line is held low for more than 35ms, ensuring that the MAX6660 can never “lock” the bus.

Remote Temperature Data Register

Two registers, at addresses 00h and 01h, store the measured temperature data from the remote diode. The data format for the remote-diode temperature is 10 bit + sign, with each bit corresponding to 0.125°C, in two's complement format (Table 2). Register 01h contains the sign bit and the first 7 bits. Bits 7, 6, 5 of Register 00h are the 3LSBs. If the two registers are not read at the same time, their contents may be the result of two different temperature measurements leading to erroneous temperature data. For this reason, a parity bit has been added to the 00h register. Bit 4 of this is zero if the data in 00h and 01h are from the same temperature conversion and are 1 if they are not. The remaining bits are “don't cares.” When reading temperature data, register 01h must be read first.

Alarm Threshold Registers

The MAX6660 provides four alarm threshold registers that can be programmed with a two's complement temperature value with each bit corresponding to 1°C. The registers are T_{HIGH}, T_{LOW}, T_{MAX}, and T_{HYST}. If the measured temperature equals or exceeds T_{HIGH}, or is less than T_{LOW}, an $\overline{\text{ALERT}}$ interrupt is asserted. If the measured temperature equals or exceeds T_{MAX}, the $\overline{\text{OVERT}}$ output is asserted (see *Over-Temperature Output ($\overline{\text{OVERT}}$)* section). If $\overline{\text{ALERT}}$ and $\overline{\text{OVERT}}$ are activated by the temperature exceeding T_{MAX}, they can only be deasserted by the temperature dropping below T_{HYST}. The POR state for T_{HIGH} is +127°C, for T_{LOW} is -55°C, for T_{MAX} is +100°C, and for T_{HYST} is +95°C.

Over-Temperature Output ($\overline{\text{OVERT}}$)

The MAX6660 has an over-temperature output ($\overline{\text{OVERT}}$) that is set when the remote-diode temperature crosses the limits set in the T_{MAX} register. It is always active if the remote-diode temperature exceeds T_{MAX}. The $\overline{\text{OVERT}}$ line clears when the temperature drops below T_{HYST}. Bit 1 of the Configuration register can be used to mask the $\overline{\text{OVERT}}$ output. Typically, the $\overline{\text{OVERT}}$ output is connected to a power-supply shutdown line to turn system power off. At power-up, $\overline{\text{OVERT}}$ defaults to active-low but the polarity can be reversed by setting bit 5 of the Configuration register.

The $\overline{\text{OVERT}}$ line can be taken active, either by the MAX6660 or driven by an external source. An external source can be masked by bit 2 of the Configuration register. When $\overline{\text{OVERT}}$ is active, the fan loop forces the fan to full speed and bit 1 of the Status register is set.

Diode Fault Alarm

A continuity fault detector at DXP detects an open circuit between DXP and DXN. If an open or short circuit exists, register 01h is loaded with 000 0000. Additionally, if the fault is an open circuit, bit 2 of the status byte is set to 1 and the ALERT condition is activated at the end of the conversion. Immediately after POR, the Status register indicates that no fault is present until the end of the first conversion.

$\overline{\text{ALERT}}$ Interrupts

The $\overline{\text{ALERT}}$ interrupt output signal is activated (unless it is masked by bit 7 in the Configuration register) whenever the remote-diode's temperature is below T_{LOW} or exceeds T_{HIGH}. A disconnected remote diode (for continuity detection), a shorted diode, or an active $\overline{\text{OVERT}}$ also activates the $\overline{\text{ALERT}}$ signal. The activation of the $\overline{\text{ALERT}}$ signal sets the corresponding bits in the Status register. There are two ways to clear the $\overline{\text{ALERT}}$: sending the ALERT Response Address or reading the Status register.

The interrupt does not halt automatic conversions. New temperature data continues to be available over the SMBus interface after $\overline{\text{ALERT}}$ is asserted. $\overline{\text{ALERT}}$ is an active-low open-drain output so that devices can share a common interrupt line. The interrupt is updated at the end of each temperature conversion so, after being cleared, reappears after the next temperature conversion, if the cause of the fault has not been removed.

By setting bit 0 in the Configuration register to 1, the Status register can only be cleared by sending the SMBus Alert Response Address (see *Alert Response Address* section). Prior to taking corrective action, always check to ensure that an interrupt is valid by reading the current temperature. To prevent recurring interrupts, the MAX6660 asserts $\overline{\text{ALERT}}$ only once per crossing of a given temperature threshold. To enable a new interrupt, the value in the limit register that triggered the interrupt must be rewritten. Other interrupt conditions can be caused by crossing the opposite temperature threshold, or a diode fault can still cause an interrupt.

Example: The remote temperature reading crosses T_{HIGH}, activating $\overline{\text{ALERT}}$. The host responds to the interrupt and reads the Alert Response Address, clearing the interrupt. The system may also read the status byte at this time. If the condition persists, the interrupt reappears. Finally, the host writes a new value to T_{HIGH}. This enables the device to generate a new T_{HIGH} interrupt if the alert condition still exists.

Alert Response Address

The SMBus Alert Response interrupt pointer provides quick fault identification for simple slave devices that lack the complex, expensive logic needed to be a bus

Remote-Junction Temperature-Controlled Fan-Speed Regulator with SMBus Interface

master. Upon receiving an ALERT interrupt signal, the host master can broadcast a Receive Byte transmission to the Alert Response slave address (see *Slave Addresses* section). Then, any slave device that generated an interrupt attempts to identify itself by putting its own address on the bus (Table 3).

The Alert Response can activate several different slave devices simultaneously, similar to the I²C General Call. If more than one slave attempts to respond, bus arbitration rules apply, and the device with the lower address code wins. The losing device does not generate an Acknowledge and continues to hold the ALERT line low until cleared. (The conditions for clearing an alert vary depending on the type of slave device.) Successful completion of the Alert Response protocol clears the interrupt latch, provided the condition that caused the alert no longer exists. If the condition still exists, the device reasserts the ALERT interrupt at the end of the next conversion.

Table 3. Read Format for Alert Response Address

BIT	NAME	FUNCTION
7 (MSB)	ADD7	Provide the current MAX6660 slave address
6	ADD6	
5	ADD5	
4	ADD4	
3	ADD3	
2	ADD2	
1	ADD1	Logic 1
0 (LSB)	1	

Command Byte Functions

The 8-bit Command Byte register (Table 4) is the master index that points to the other registers within the MAX6660. The register's POR is 0000 0000, so that a receive byte transmission (a protocol that lacks the command byte) that occurs immediately after POR returns the current remote temperature data.

One-Shot

The one-shot command immediately forces a new conversion cycle to begin. In software standby mode (RUN/STOP bit = high), a new conversion is begun, after which the device returns to standby mode. If a conversion is in progress when a one-shot command is received, the command is ignored. If a one-shot command is between conversions, in autoconvert mode (RUN/STOP bit = low), a new conversion begins immediately.

Configuration Byte Functions

The Configuration Byte register (Table 5) is used to mask (disable) the $\overline{\text{ALERT}}$ signal to place the device in software standby mode, to change the polarity of $\overline{\text{OVERT}}$, to set MAX6660 to thermal open/closed-loop mode, to inhibit the $\overline{\text{OVERT}}$ signal, to mask $\overline{\text{OVERT}}$ output, and to clear the $\overline{\text{ALERT}}$ signal. The MAX6660 has a write protection feature (bit 4) that prohibits write commands to bits 6–3 of the Configuration register. It also prohibits writes to the T_{MAX}, T_{HYST}, and Fan Conversion Rate registers.

Status Byte Functions

The status byte (Table 6) reports several fault conditions. It indicates when the fan driver transistor of the MAX6660 has overheated and/or is thermal shutdown, when the temperature thresholds, T_{LOW} and T_{HIGH}, have been exceeded, and whether there is an open circuit in the DXP-DXN path. The register also reports the state of the $\overline{\text{ALERT}}$ and $\overline{\text{OVERT}}$ lines and indicates when the fan driver is fully on. The final bit in the Status register indicates when a fan failure has occurred.

After POR, the normal state of the flag bits is zero, assuming no alert or overtemperature conditions are present. Bits 2 through 6 of the Status register are cleared by any successful read of the Status register, unless the fault persists. The $\overline{\text{ALERT}}$ output follows the status flag bit. Both are cleared when successfully read, but if the condition still exists, the ALERT is reasserted at the end of the next conversion.

The MAX6660 incorporates collision avoidance so that completely asynchronous operation is allowed between SMBus operations and temperature conversions.

When autoconverting, if the T_{HIGH} and T_{LOW} limits are close together, it is possible for both high-temperature and low-temperature status bits to be set, depending on the amount of time between status read operations. In these circumstances, it is best not to rely on the status bits to indicate reversals in long-term temperature changes. Instead, use a current temperature reading to establish the trend direction.

Manufacturer and Device ID Codes

Two ROM registers provide manufacturer and device ID codes. Reading the manufacturer ID returns 4D, which is the ASCII code M (for Maxim). Reading the device ID returns 09h, indicating the MAX6660 device. If READ WORD 16-bit SMBus protocol is employed (rather than the 8-bit READ BYTE), the LSB contains the data and the MSB contains 00h in both cases.

Remote-Junction Temperature-Controlled Fan-Speed Regulator with SMBus Interface

Table 4. Command-Byte Bit Assignments

REGISTERS	COMMAND	POR STATE	FUNCTION
RRL	00h	00000000	Read Remote Temperature Low Byte (3MSBs)
RRH	01h	00000000	Read Remote Temperature High Byte (Sign Bit and First 7 Bits)
RSL	02h	00000000	Read Status Byte
RCL/WCL	03h/09h	00000000	Read/Write Configuration Byte
RFRC/WFCR	04h/0Ah	00000010	Read/Write Fan-Conversion Rate Byte
RTMAX/WTMAX	10h/12h	01100100 at +100°C	Read/Write Remote T _{MAX}
RTHYST/WTHYST	11h/13h	01011111 at +95°C	Read/Write Remote T _{HYST}
RTHIGH/WTHIGH	07h/0Dh	01111111 at +127°C	Read/Write Remote T _{HIGH}
RTLW/WTLOW	08h/0Eh	11001001 at -55°C	Read/Write Remote T _{LOW}
SPOR	FCh	N/A	Write Software POR
OSHT	0Fh	N/A	Write One-Shot Temperature Conversion
RTFAN/WTFAN	14h/19h	00111100 at +60°C	Read/Write Fan-Control Threshold Temperature T _{FAN}
RFSC/WFSC	15h/1Ah	00000000	Read/Write Fan-Speed Control
RFG/WFG	16h/1Bh	10000000	Read/Write Fan Gain
RFTC	17h	00000000	Read Fan Tachometer Count
RFTCL/WFTCL	18h/1Ch	11111111	Read/Write Fan Tachometer Count Limit (Fan Failure Limit)
RFCD/WFCD	1Dh/1Eh	00000001	Read/Write Fan Count Divisor
RFS/WFS	1Fh/20h	11111111	Read/Write Full-Scale Register
RM/WM	FAh/FBh	00000000	Read/Write Mode Register
ID Code	FEh	01001101	Read Manufacturer ID Code
ID Code	9Dh	00001001	Read Device ID Code

Slave Addresses

The MAX6660 can be programmed to have one of nine different addresses by pin strapping ADD0 and ADD1 so that up to nine MAX6660s can reside on the same bus without address conflicts. See Table 7 for address information.

The address pin state is checked at POR only, and the address data stays latched to reduce quiescent supply current due to the bias current needed for high-Z state detection.

The MAX6660 also responds to the SMBus Alert Response slave address (see the *Alert Response Address* section).

POR and UVLO

The MAX6660 has a volatile memory. To prevent unreliable power-supply conditions from corrupting the data in memory and causing erratic behavior, a POR voltage detector monitors V_{CC} and clears the memory if V_{CC} falls below 1.91V (typ, see *Electrical Characteristics*). When power is first applied and V_{CC} rises above 2.0V (typ), the logic blocks begin operating, although reads and writes at V_{CC} levels below 3.0V are not recommended. A second V_{CC} comparator, the ADC under-voltage lockout (UVLO) comparator prevents the ADC from converting until there is sufficient headroom (V_{CC} = 2.8V typ).

The SPOR software POR command can force a power-on reset of the MAX6660 registers through the serial interface. Use the SEND BYTE protocol with COMMAND = FCh.

Remote-Junction Temperature-Controlled Fan-Speed Regulator with SMBus Interface

MAX6660

Table 5. Configuration-Byte Bit Assignments

BIT	NAME	POR STATE	DESCRIPTION
7(MSB)	$\overline{\text{ALERT}}$ Mask	0	When set to 1, $\overline{\text{ALERT}}$ is masked from internally generated errors.
6	Run/Stop	0	When set to 1, the MAX6660 enters low-power standby.
5	$\overline{\text{OVERT}}$ Polarity	0	0 provides active low, 1 provides active high.
4	Write Protect	0	When set to 1, Write Protect is in effect for the following applicable registers: 1. Configuration register bits 6, 5, 4, 3 2. T_{MAX} register 3. T_{HYST} register 4. Fan Conversion Rate register
3	Thermal Closed/ Open Loop	0	When set to 1, the thermal loop is open. The Fan Speed Control retains the last closed-loop value unless overwritten by a bus command (in closed loop, the Fan Speed Control is read only). If Fan Mode is set to Open Loop by writing a 1 to bit 0 of the Fan Gain register, then this bit is automatically set.
2	$\overline{\text{OVERT}}$ Input Inhibit	0	When set to 1, an external signal on $\overline{\text{OVERT}}$ is masked from bit 1 of the Status register.
1	Mask $\overline{\text{OVERT}}$ Output	0	Mask the $\overline{\text{OVERT}}$ output from an internally generated overtemperature error.
0	$\overline{\text{ALERT}}$ Clear Mode	0	When 0, reading the Status register clears or sending an Alert Response Request clears $\overline{\text{ALERT}}$ (if the fault condition is no longer true). When set high, only an Alert Response Request clears $\overline{\text{ALERT}}$.

Table 6. Status-Byte Bit Assignments

BIT	NAME	POR STATE	DESCRIPTION
7 (MSB)	MAX6660 Overheat	0	When high, indicates that the fan driver transistor of the MAX6660 has overheated (temp > +150°C) and is in thermal shutdown. The fan driver remains disabled until temperature falls below +140°C.
6	$\overline{\text{ALERT}}$	0	When high, indicates $\overline{\text{ALERT}}$ has been activated (pulled low), regardless of cause (internal or external).
5	Fan Driver Full Scale	0	When high, indicates the fan driver is at full scale. Only valid in fan closed-loop mode (Register FG B170 = 0). Set to high in fan open-loop mode (Register FG B170 = 1).
4	Remote High	0	When high, the remote-junction temperature exceeds the temperature in the Remote High register.
3	Remote Low	0	When high, the remote-junction temperature is lower than the temperature in the Remote Low register.
2	Diode Open	0	When high, the remote-junction diode is open.
1	$\overline{\text{OVERT}}$	0	When high, indicates that $\overline{\text{OVERT}}$ has been activated, regardless of cause (internal or external).
0	Fan Failure	0	When high, indicates the count in the Fan Tachometer Count register is higher than the limit set in the Fan Tachometer Count Limit register.

Remote-Junction Temperature-Controlled Fan-Speed Regulator with SMBus Interface

Table 7. POR Slave Address Decoding (ADD0 and ADD1)

ADD0	ADD1	ADDRESS
GND	GND	0011 000
GND	High-impedance	0011 001
GND	V _{CC}	0011 010
High-impedance	GND	0101 001
High-impedance	High-impedance	0101 010
High-impedance	V _{CC}	0101 011
V _{CC}	GND	1001 100
V _{CC}	High-impedance	1001 101
V _{CC}	V _{CC}	1001 110

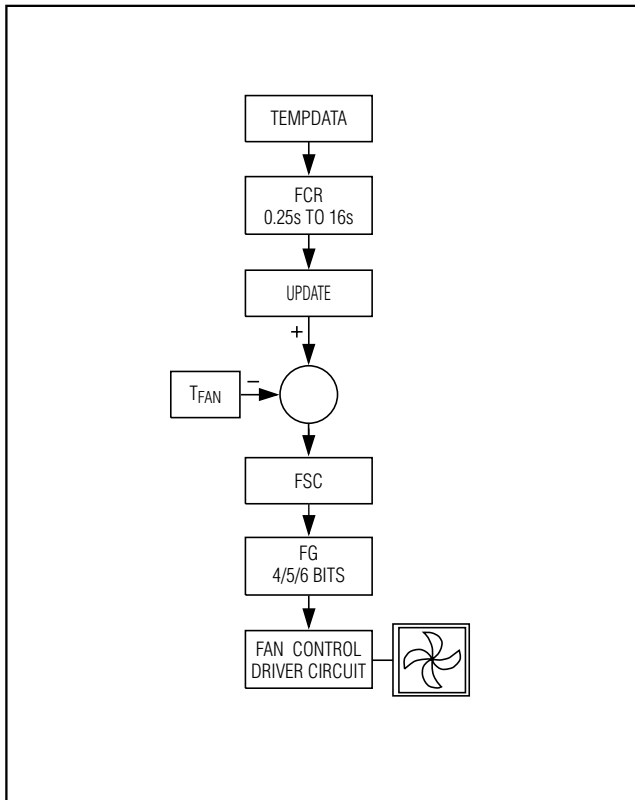

Figure 6. MAX6660 Thermal Loop

Power-up defaults include:

- Interrupt latch is cleared.
- ADC begins autoconverting.
- Command register is set to 00h to facilitate quick internal Receive Byte queries.
- T_{HIGH} and T_{LOW} registers are set to +127°C and -55°C, respectively.
- T_{HYST} and T_{MAX} are set to +95°C and +100°C, respectively.

Fan Control

The fan-control function can be divided into the thermal loop, the fan-speed-regulation loop (fan loop), and the fan-failure sensor. The thermal loop sets the desired fan speed based on temperature while the fan-speed-regulation loop uses an internally divided down reference oscillator to synchronize to and regulate the fan speed. The fan-speed-regulation loop includes the fan driver and the tachometer sensor. The fan-failure sensor provides a FAN FAIL alarm that signals when the fan tachometer count is greater than the fan tachometer value, which corresponds to a fan going slower than the limit. The fan driver is an N-channel, 4Ω, 320mA MOSFET with a 16V maximum V_{DS} whose drain terminal connects to the low side of the fan. The tachometer sensor (TACH IN) of the MAX6660 is driven from the tachometer output of the fan and provides the feedback signal to the fan-speed-regulation loop for controlling the fan speed. For fans without tachometer outputs, the MAX6660 can generate its own tachometer pulses by monitoring the commutating current pulses (see *Commutating Current Pulses* section).

Thermal Loop

Thermal Closed Loop

The MAX6660 can be operated in a complete closed-loop mode, with both the thermal and fan loops closed, where the remote-diode sensor temperature directly controls fan speed. Setting bit 3 of the Configuration register to zero places the MAX6660 in thermal closed loop (Figure 6). The remote-diode temperature sensor is updated every 250ms. The value is stored in a temporary register (TEMPDATA) and compared to the programmed temperature values in the T_{HIGH}, T_{LOW}, T_{HYST}, T_{MAX}, and T_{FAN} registers to produce the error outputs OVERT and ALERT.

The Fan Conversion Rate (FCR) register (Table 8) can be programmed to update the TEMPDATA every 0.25s

Remote-Junction Temperature-Controlled Fan-Speed Regulator with SMBus Interface

to 16s and stores the data in an update register (UPDATE). This enables control over timing of the thermal feedback loop to optimize stability.

The Fan Threshold (T_{FAN}) register value is subtracted from the UPDATE register value. If UPDATE exceeds T_{FAN} temperature, then the Fan-Speed Control (FSC) register (Table 9) stores the excess temperature in the form of a 7-bit word with an LSB of 0.5°C for bits 4–0, with bit 5 = 16°C. If the difference between the T_{FAN} and UPDATE registers is higher than 32°C, then bit 6 is set to 1, along with bits 5–1. In thermal closed loop, the Fan Speed Control register is READ ONLY.

The Fan Gain (FG) register (Table 10) determines the number of bits used in the Fan-Speed Control register. This gain can be set to 4, 5, or 6. If bits 6 and 5 are set to 10, all 6 bits of TEMPDATA are used directly to program the speed of the fan so that the thermal loop has a control range of +32°C with 64 temperature steps

from fan off to full fan speed. If bits 6 and 5 are set to 01, the thermal control loop has a control range of 16°C with 32 temperature steps from fan off to full fan speed. If bits 6 and 5 are set to 00, the thermal control loop has a control range of 8°C with 16 temperature steps from fan off to full fan speed.

Thermal Open Loop

Setting bit 3 of the Configuration register (Table 5) to 1 places the MAX6660 in thermal open loop. In thermal open-loop mode, the FSC register is read/write and contains the 7-bit result of UPDATE subtracted from T_{FAN} .

In fan open loop, the FSC register programs fan voltage with acceptable values from 0 to 64 (40h). For example, in fan open-loop mode, 0 corresponds to zero output and 40h corresponds to full fan voltage, for example (11.3V, typ). Proportional control is available over the 0 to 63 (3Fh) range with 64 (40h) forcing unconditional full speed. In fan closed-loop mode, 0 corresponds to zero fan speed and 10h corresponds to 100% fan speed, when the FG register is set to 4 bits, 20h at 5 bits, and 3Fh at 6 bits.

Fan Loop

The fan controller (Figure 7) is based on an up/down counter where there is a reference clock representing the desired fan speed counting up, while tachometer pulses count down. The reference clock frequency is divided down from the MAX6660 internal clock to a frequency of 8415Hz. This clock frequency is further divided by the Fan Full-Scale (FS) register (Table 11), which is limited to values between 127 to 255, for a

Table 8. Fan Conversion Update Rate

DATA	BINARY	FAN UPDATE RATE (Hz)	SECONDS BETWEEN UPDATES
00h	00000000	0.0625	16
01h	00000001	0.125	8
02h	00000010	0.25	4 (POR)
03h	00000011	0.5	2
04h	00000100	1	1
05h	00000101	2	0.5
06h	00000110	4	0.25

Table 9. Fan-Speed Control Register (RFSC/W FSC)

REGISTER/ ADDRESS	FSC (15h = READ, 1Ah = WRITE)							
COMMAND	READ/WRITE FAN DAC REGISTER							
Bit	7 N/A	6 Overflow Bit	5 (MSB)	4 Data	3 Data	2 Data	1 Data	0 Data
POR State	0	0	0	0	0	0	0	0

Note: In thermal closed-loop mode, the fan DAC is read only and contains the difference between the measured temperature and the fan threshold temperature. The LSB is 0.5°C and bit 5 is 16°C. If the difference is higher than 32°C, then bit 6 is set to 1, together with bits 5–0. Bit 6 can be regarded as an overflow bit for differences higher than 32°C. Bit 7 is always zero. The FSC register can be programmed directly in thermal open mode. In fan closed-loop mode, FSC programs fan speed with acceptable values from 0 to 10h, when FG is set to 4 bits or 20h when FG is set to 5 bits, or 3F when FG is set to 6 bits. In fan open-loop mode, FSC programs fan voltage with acceptable values from 0 to 64 (40h). For example, in fan closed-loop mode, zero corresponds to zero fan speed and 10h corresponds to 100% fan speed. In fan open-loop mode, zero corresponds to zero volts out and 40h corresponds to full fan voltage (11.3V typ).

Remote-Junction Temperature-Controlled Fan-Speed Regulator with SMBus Interface

range of reference clock full-scale frequencies from 33Hz to 66Hz. A further division is performed to set the actual desired fan speed. This value appears in the Fan-Speed Control register in thermal closed-loop mode. If the thermal loop is open, but the fan-speed control loop is closed, this value is programmable in the fan DAC. When in fan open-loop mode (which forces the thermal loop to open), the FSC register becomes a true DAC, programming the voltage across the fan from zero to nearly 12V to V_{VFAN} .

The tachometer input (TACH IN) includes a programmable (1/2/4/8) prescaler. The divider ratio for the (1/2/4/8) prescaler is stored in the Fan Count Divisor (FCD) register (Table 12). In general, the values in FC

should be set such that the full-speed fan frequency divided by the prescaler fall in the 33Hz to 66Hz range.

The (UP/DN) counter has six stages that form the input of a 6-bit resistive ladder DAC whose voltage is divided down from V_{VFAN} . This DAC determines the voltage applied to the fan. Internal coding is structured such that when in fan closed-loop mode (which includes thermal closed loop) that higher values in the 0 to 32 range correspond to higher fan speeds and greater voltage across the fan. In fan open-loop mode (which forces thermal open loop) acceptable values range from 0 to 63 (3Fh) for proportional control; a value of 64 (40h) commands unconditional full speed.

Table 10. Fan Gain Register (RFG/WFG)

REGISTER/ ADDRESS	FG (16h = READ, 1Bh = WRITE)							
COMMAND	READ/WRITE FAN GAIN REGISTER							
Bit	7 Reserved	6 Fan Gain	5 Fan Gain	4	3	2 SMBus Timeout	1 Fan Feedback Mode	0 Fan Driver Mode
POR State	1	0	0	x	x	x	0	0

Notes:

Bit 7: Reserved. Always 1. If bit 7 is written to zero, then bits 7, 6, and 5 are set to 100.

Bits 6, 5: Fan gain of the fan loop, where 00 = 8°C with resolution = 4 bits. This means that the fan reaches its full-scale (maximum) speed when there is an 8°C difference between the remote-diode temperature and the value stored in TFAN, 01 = 16°C, with a 5-bit resolution and 10 = 32°C with a 6-bit resolution.

Bits 4, 3: Reserved.

Bit 2: SMBus Timeout. When 1, the SMBus timeout is disabled. This permits full I²C compatibility with minimum clock frequency to DC.

Bit 1: Fan feedback mode. When bit 1 is set to 1, the fan loop uses driver current sense rather than tachometer feedback.

Bit 0: Fan Driver Mode. When bit 0 is set to 1, the fan driver is in fan open-loop mode. In this mode, the fan DAC programs the fan voltage rather than the fan speed. Tachometer feedback is ignored, and the user must consider minimum fan drive and startup issues. Thermal open loop is automatically set to 1 (see Configuration register). Fan Fail (bit 0 of the Status register) is set to 1 in this mode and should be ignored.

Table 11. Fan Full-Scale Register (RFS/WFS)

REGISTER/ ADDRESS	FS (1Fh = READ, 20h = WRITE)							
COMMAND	READ/WRITE MAXIMUM TEMPERATURE LIMIT BYTE							
Bit	7 (MSB)	6 Data Bit	5 Data Bit	4 Data Bit	3 Data Bit	2 Data Bit	1 Data Bit	0 Data Bit
POR State	1	1	1	1	1	1	1	1

Note: This register determines the maximum reference frequency at the input of the phase detector. It controls a programmable divider that can be set anywhere between 127 and 255. The value in this register must be set in accordance with the procedure described in the TACH IN section (equivalent to $8415/(\text{Fan Frequency}/\text{Fan Count Divisor})$). Programmed value below 127 defaults to 127. POR value is 255.

Remote-Junction Temperature-Controlled Fan-Speed Regulator with SMBus Interface

MAX6660

Table 12. Fan Count Divisor Register (RFCD/WFCD)

REGISTER/ ADDRESS	FCD (1Dh = READ, 1Eh = WRITE)							
COMMAND	READ LIMIT/FAILURE REGISTER							
Bit	7	6	5	4	3	2	1	0
POR State	0	0	0	0	0	0	0	1

Notes: This byte sets the prescalar division ratio for tachometer or current-sense feedback. (This register does not apply to the tach signal used in the Fan-Speed register). Select this value such that the fan frequency (RPM/60 x number of poles) divided by the FCD falls in the 33Hz to 66Hz range. See *TACH IN* section.
 Bits 1, 0: 00 = divide by 1, 01 = divide by 2, 10 = divide by 4, 11 = divide by 8.

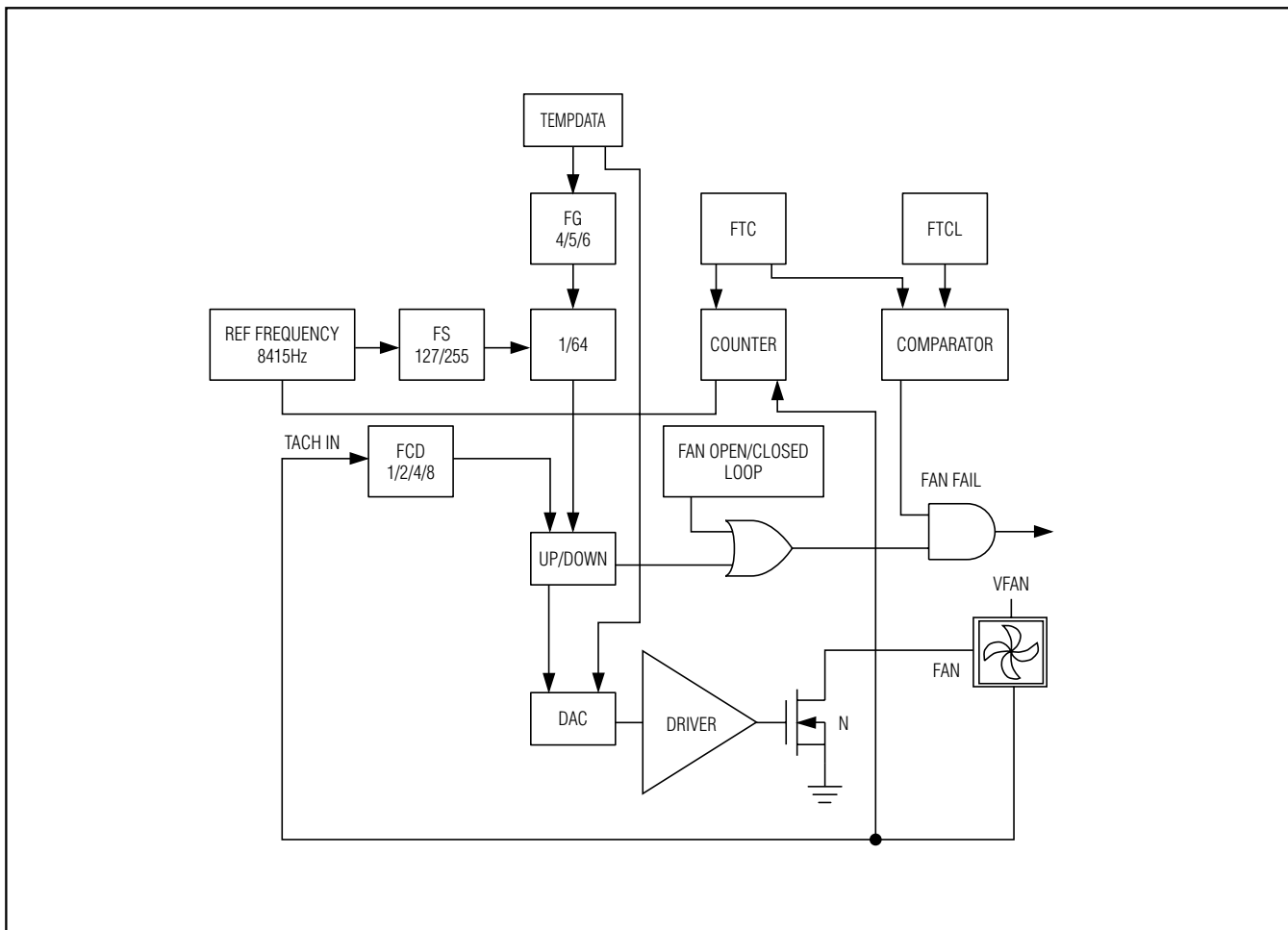

Figure 7. MAX6660 Fan Loop Functional Diagram

Remote-Junction Temperature-Controlled Fan-Speed Regulator with SMBus Interface

Fan Conversion Rate Byte

The FCR register (Table 8) programs the fan's update time interval in free-running autonomous mode (RUN/STOP = 0). The conversion rate byte's POR state is 02h (0.25Hz). The MAX6660 uses only the 3LSBs of this register. The 4MSBs are "don't cares." The update rate tolerance is $\pm 25\%$ (max) at any rate setting.

Fan Closed Loop

In the thermal open loop but fan closed-loop mode, the feedback loop can be broken and the temperature data read directly. After performing external manipulations, the result can be injected back into the fan control loop by writing to the FSC register to control fan speed. Fan closed-loop mode is selected by setting bit 0 of the FG to zero.

Fan Open Loop

In fan control open-loop mode, selected by setting bit 0 of the FG register to 1, the gain block is bypassed and the FSC register is used to program the fan voltage rather than the fan speed. In the fan open-loop mode, both the temperature feedback loop and fan-speed control loop are broken, which results in the TACH IN input becoming disabled. A direct voltage can be applied after reading the temperature, using the FSC register, to the fan that provides more flexibility in external control algorithms. By selecting fan open-loop mode, the MAX6660 automatically invokes thermal open-loop mode.

Fan Driver

The fan driver consists of an amplifier and low-side NMOS device whose drain is connected to FAN and is the input from the low side of the fan. The FET has a typical 4Ω on-resistance with a typical 320mA maximum current limit. The driver has a thermal shutdown sensor that senses the driver's temperature. It shuts down the driver if the temperature exceeds $+150^\circ\text{C}$. The driver is reactivated once the temperature has dropped below $+140^\circ\text{C}$.

TACH IN

The TACH IN input connects directly to the tachometer output of a fan. Most commercially available fans have two tachometer pulses per revolution. The tachometer input is fully compatible with tachometer signals, which are pulled up to V_{VFAN} .

Commutating Current Pulses

When a fan does not come equipped with a tachometer output, the MAX6660 uses commutating generated current pulses for speed detection. This mode is entered by setting the FG register's bit 1 to 1. An internal current pulse is generated whenever a step increase occurs in the fan current. Connecting an external resistor between the GAIN pin and V_{CC} can reduce the sensitivity of current pulses to changes in fan current. In general, the lower the resistor value, then the lower the sensitivity, and the fan is easier to turn ON and can use a smaller external capacitor across its terminals. A suitable resistor range is $1\text{k}\Omega$ to $5\text{k}\Omega$.

Fan-Failure Detection

The MAX6660 detects fan failure by comparing the value in the Fan Tachometer Count (FTC) register, a READ ONLY register, with a limit stored in the Fan Tachometer Count Limit (FTCL) register (Table 13). A counter counts the number of on-chip oscillator pulses between successive tachometer pulses and loads the FTC register every time a tachometer pulse arrives. If the value in FTC is greater than the value in FTCL, a failure is indicated. In fan closed loop, a flag is activated when the fan is at full speed.

Set the Fan Tachometer Limit Byte to:

$$f_L = 8415/[N \times f]$$

where N = fan fail ratio and f = frequency of fan tachometer.

The factor N is less than 1 and produces a fan failure indication when the fan should be running at full speed but is only reaching a factor N of its expected frequency. The factor N is typically set to 0.75 for all fan

Table 13. Fan Tachometer Count Limit (RFTCL/WFTCL)

REGISTER/ ADDRESS	FL (18h = READ, 1Ch = WRITE)							
COMMAND	READ LIMIT/FAILURE REGISTER							
BIT	7 (MSB)	6	5	4	3	2	1	0
POR STATE	1	1	1	1	1	1	1	1

Note: The Fan Limit register is programmed with the maximum speed that is compared against the value in the FS register (Address 17) to produce an error output to the Status register.

Remote-Junction Temperature-Controlled Fan-Speed Regulator with SMBus Interface

speeds except at very low speeds where a fan failure is indicated by an overflow of the fan speed counter rather than f_L . The overflow flag cannot be viewed separately in the Status Byte but is ORed with bit 0, the fan fail bit.

Applications Information

Mode Register

Resistance in series with the remote-sensing junction causes conversion errors on the order of 0.5°C per ohm.

The MAX6660 Mode register gives the ability to eliminate the effects of external series resistance of up to several hundred ohms on the remote temperature measurement and to adjust the temperature measuring ADC to suit different types of remote-diode sensor. For systems using external switches or long cables to connect to the remote sensor, a parasitic resistance cancellation mode can be entered by setting Mode register bit 7 = 1. This mode requires a longer conversion time and so can only be used for fan conversion rates of 1Hz or slower. Bits 6, 1, and 0 are Reserved. Use bits 5–2 to adjust the ADC gain to achieve accurate temperature measurements with diodes not included in the recommended list or to individually calibrate the MAX6660 for use in specific control systems. These bits adjust gain to set the temperature reading at +25°C, using two's complement format reading. Bit 5 is the sign (1 = increase, 0 = decrease), bit 4 = 2°C shift, bit 3 = 1°C shift, bit 2 = 1/2°C shift.

General Programming Techniques

The full-scale range of the fan regulation loop is designed to accommodate fans operating between the 1000rpm to 8000rpm range of different fans. An on-chip 8415Hz oscillator is used to generate the 33Hz to 66Hz reference frequency. Choose the prescalar such that the fan full-speed frequency divided by the prescalar falls in the 33Hz to 66Hz range. The full-scale reference frequency is further divided by the value in the FSC register to the desired fan frequency [read: speed].

- 1) Determine the fan's maximum tachometer frequency:

$$f = \left(\frac{\text{RPM}}{60} \right) \times \text{poles}$$

Where poles = number of tachometer poles (pulses per revolution). Most fans are two poles; therefore, two pulses per revolution.

- 2) Set the programmable FCD to a value P so that the above frequency falls in the 33Hz to 66Hz range.
- 3) Determine the value required for the Fan FS register:

$$FS = \frac{8415}{\left(\frac{f}{P} \right)}$$

Example: Fan A has a 2500rpm rating:

2500rpm / 60s gives an output of 41.7Hz

41.7Hz x 2 pulses = 83.4Hz

The 83.4Hz value is out of the 33Hz to 66Hz decrement/increment range.

- 4) Set bits in the FC register to divide the signal down within the 33Hz to 66Hz range. Bits 1, 0 = 10 (divide by 2: P = 2):

$$83.4 / 2 = 41.7\text{Hz}$$

- 5) Set the FS register to yield approximately 42Hz:

$$42 = 8415 / FS \text{ (value)}$$

$$FS \text{ (value)} = 200$$

$$FS \text{ register} = 11001000$$

- 6) In current-sense feedback, a current pulse is generated whenever there is a step increase in fan current. The frequency of pulses is then not only determined by the fan rpms and the number of poles, but also by the update rate at which the fan driver forces an increase in voltage across the fan. The maximum current pulse frequency is then given by:

$$f_C = f \times P / (P-1)$$

Where $f = \{\text{RPM}/60\} \times \text{poles}$ and P is the value in FCD.

The value required for the fan FS register is:

$$FS = 8415 / \{f / (P-1)\}$$

The fan speed limit in FCTL should be set to:

$$f_L = 8415 / (N \times f_C)$$

A value of P = 1 cannot be used in current-sense mode.

Fan Selection

For closed-loop operation and fan monitoring, the MAX6660 requires fans with tachometer outputs. A tachometer output is typically specified as an option on many fan models from a variety of manufacturers. Verify

Remote-Junction Temperature-Controlled Fan-Speed Regulator with SMBus Interface

Table 14. Fan Manufacturers

MANUFACTURER	FAN MODEL OPTION
Comair Roton	All DC brushless models can be ordered with optional tachometer output.
EBM-Papst	Tachometer output optional on some models.
NMB	All DC brushless models can be ordered with optional tachometer output.
Panasonic	Panaflo and flat unidirectional miniature fans can be ordered with tachometer output.
Sunon	Tachometer output optional on some models.

the nature of the tachometer output (open collector, totem pole) and the resultant levels and configure the connection to the MAX6660. For a fan with an open drain/collector output, a pullup resistor of typically 5k Ω must be connected between FAN and VFAN. Note how many pulses per revolution are generated by the tachometer output (this varies from model to model and among manufacturers, though two pulses per revolution is the most common). Table 14 lists the representative fan manufacturers and the model they make available with tachometer outputs.

Low-Speed Operation

Brushless DC fans increase reliability by replacing mechanical commutation with electronic commutation. By lowering the voltage across the fan to reduce its speed, the MAX6660 is also lowering the supply voltage for the electronic commutation and tachometer electronics. If the voltage supplied to the fan is lowered too far, the internal electronics may no longer function properly. Some of the following symptoms are possible:

- The fan may stop spinning.
- The tachometer output may stop generating a signal.
- The tachometer output may generate more than two pulses per revolution.
- The problems that occur and the supply voltages at which they occur depend on which fan is used. As a rule of thumb, 12V fans can be expected to experience problems somewhere around 1/4 and 1/2 their rated speed.

Chip Information

TRANSISTOR COUNT: 22,142

PROCESS: BiCMOS

Pin Configuration

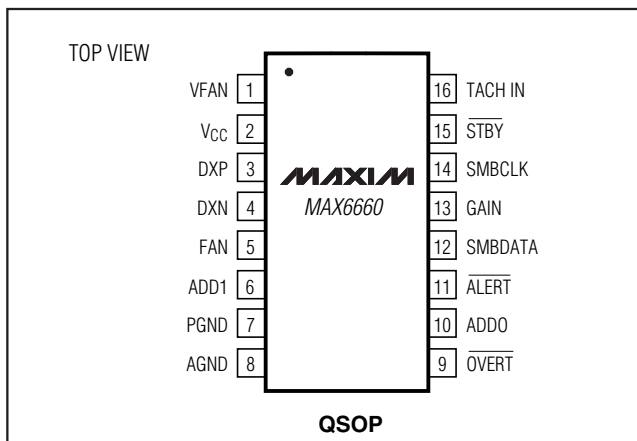

Remote-Junction Temperature-Controlled Fan-Speed Regulator with SMBus Interface

Package Information

(The package drawing(s) in this data sheet may not reflect the most current specifications. For the latest package outline information, go to www.maxim-ic.com/packages.)

MAX6660

QSOP-EPS

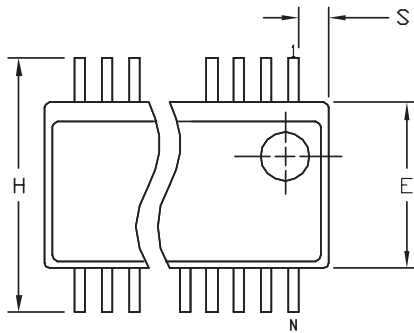

DIM	INCHES		MILLIMETERS	
	MIN	MAX	MIN	MAX
A	.053	.069	1.35	1.75
A1	.004	.010	.102	.254
A2	.049	.065	1.245	1.651
B	.008	.012	0.20	0.30
C	.0075	.0098	0.191	0.249
D	SEE VARIATIONS			
E	.150	.157	3.81	3.99
e	.025 BSC		0.635 BSC	
H	.230	.244	5.84	6.20
h	.010	.016	0.25	0.41
L	.016	.035	0.41	0.89
N	SEE VARIATIONS			
α	0°	8°	0°	8°

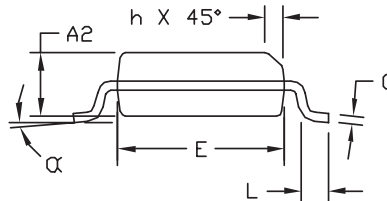
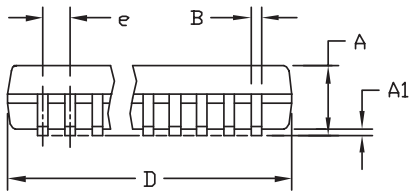

VARIATIONS:

DIM	INCHES		MILLIMETERS		N
	MIN.	MAX.	MIN.	MAX.	
D	.189	.196	4.80	4.98	16 AB
S	.0020	.0070	0.05	0.18	
D	.337	.344	8.56	8.74	20 AD
S	.0500	.0550	1.270	1.397	
D	.337	.344	8.56	8.74	24 AE
S	.0250	.0300	0.635	0.762	
D	.386	.393	9.80	9.98	28 AF
S	.0250	.0300	0.635	0.762	

NOTES:

- 1). D & E DO NOT INCLUDE MOLD FLASH OR PROTRUSIONS.
- 2). MOLD FLASH OR PROTRUSIONS NOT TO EXCEED .006" PER SIDE.
- 3). CONTROLLING DIMENSIONS: INCHES.
- 4). MEETS JEDEC MO137.

DALLAS SEMICONDUCTOR **MAXIM**

PROPRIETARY INFORMATION

TITLE: PACKAGE OUTLINE, QSOP .150", .025" LEAD PITCH

APPROVAL:	DOCUMENT CONTROL NO. 21-0055	REV. F	1/1
-----------	---------------------------------	-----------	-----

Maxim cannot assume responsibility for use of any circuitry other than circuitry entirely embodied in a Maxim product. No circuit patent licenses are implied. Maxim reserves the right to change the circuitry and specifications without notice at any time.

Maxim Integrated Products, 120 San Gabriel Drive, Sunnyvale, CA 94086 408-737-7600 _____ 21

Looking for pricing, stock, or lifecycle information?

Click below to explore more details on WIN SOURCE:

 [View MAX6660AEE+ on WIN SOURCE](#)

 [Maxim Integrated](#) Information

Optimize Your Supply Chain with WIN SOURCE Solutions

-  Global Sourcing Solution
-  Obsolete Management
-  Cost Control Management
-  Shortage Management
-  Alternative Solution
-  Excess Inventory Management