



# THE DATASHEET OF MAX6626RMUT-T



# MAX6625/MAX6626

# 9-Bit/12-Bit Temperature Sensors with I<sup>2</sup>C-Compatible Serial Interface in a SOT23

## General Description

The MAX6625/MAX6626 combine a temperature sensor, a programmable overtemperature alarm, and an I<sup>2</sup>C-compatible serial interface into single compact packages. They convert their die temperatures into digital values using internal analog-to-digital converters (ADCs). The result of the conversion is held in a temperature register, readable at any time through the serial interface. A dedicated alarm output, OT, activates if the conversion result exceeds the value programmed in the high-temperature register. A programmable fault queue sets the number of faults that must occur before the alarm activates, preventing spurious alarms in noisy environments. OT has programmable output polarity and operating modes.

The MAX6625/MAX6626 feature a shutdown mode that saves power by turning off everything but the power-on reset and the I<sup>2</sup>C-compatible interface. Four separate addresses can be configured with the ADD pin, allowing up to four MAX6625/MAX6626 devices to be placed on the same bus. The MAX6625P/MAX6626P OT outputs are open drain, and the MAX6625R/MAX6626R OT outputs include internal pullup resistors.

The MAX6625 has a 9-bit internal ADC and can function as a replacement for the LM75 in most applications. The MAX6626 has a 12-bit internal ADC. Both devices come in the space-saving 6-pin SOT23 package, or the 6-pin TDFN package.

## Applications

- Fan Control
- Temperature Alarms
- System Temperature Control
- Industrial Equipment

## Pin Configuration

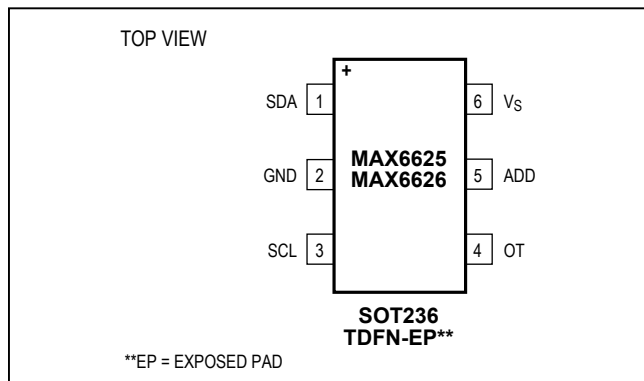

## Features

- 9-Bit Temperature-to-Digital Converter (MAX6625)
- 12-Bit Temperature-to-Digital Converter (MAX6626)
- I<sup>2</sup>C-Compatible Serial Interface
- Up to Four Devices on a Single Bus
- Versatile Alarm Output with Programmable Trip Temperature and Hysteresis
- Low-Power Shutdown Mode
- Space-Saving TDFN or SOT23 Packages
- Lead-Free Version Available (TDFN Package)

## Ordering Information

PART	TEMP RANGE	PIN-PACKAGE
MAX6625PMUT*	-55°C to +125°C	6 SOT23
MAX6625RMUT*	-55°C to +125°C	6 SOT23
MAX6625PMTT*	-55°C to +125°C	6 TDFN-EP**
MAX6625RMTT*	-55°C to +125°C	6 TDFN-EP**
MAX6626PMUT*	-55°C to +125°C	6 SOT23
MAX6626RMUT*	-55°C to +125°C	6 SOT23
MAX6626PMTT*	-55°C to +125°C	6 TDFN-EP**
MAX6626RMTT*	-55°C to +125°C	6 TDFN-EP**

\*For device options, see Selector Guide at end of data sheet. Requires special solder temperature profile described in the Absolute Maximum Ratings section.

\*\*EP = Exposed pad.

# Indicates an RoHS-compliant part

Ordering Information is continued at end of data sheet.

## Typical Operating Circuit

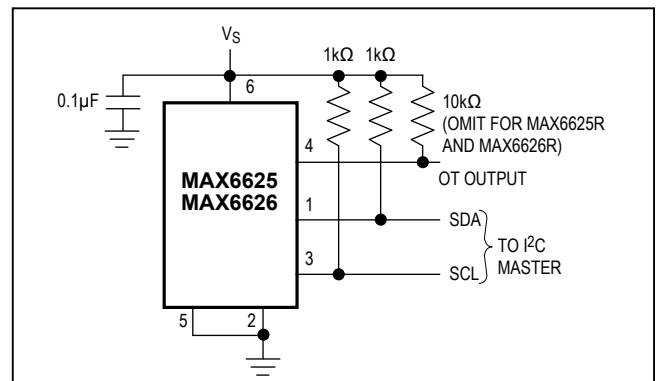

**Absolute Maximum Ratings**

V <sub>S</sub> to GND.....	-0.3V to +6V	Continuous Power Dissipation
OT, SCL, SDA to GND .....	-0.3V to +6V	6-Pin SOT23 (derate 9.1mW/°C above +70°C) .....
ADD to GND.....	-0.3V to (V <sub>S</sub> + 0.3V)	6-Pin TDFN (derate 23.8mW/°C above +70°C) .....
Current into Any Pin .....	±5mA	Junction Temperature.....
OT Sink Current .....	20mA	Storage Temperature Range.....
		ESD Rating (Human Body Model) .....
		Lead Temperature .....

**Note 1:** This device is constructed using a unique set of packaging techniques that impose a limit on the thermal profile the device can be exposed to during board-level solder attach and rework. This limit permits only the use of the solder profiles recommended in the industry-standard specification, IPC/JEDEC J-STD-020A, paragraph 7.6, Table 3 for IR/VPR and Convection Reflow. Preheating is required. Hand or wave soldering is not allowed.

*Stresses beyond those listed under "Absolute Maximum Ratings" may cause permanent damage to the device. These are stress ratings only, and functional operation of the device at these or any other conditions beyond those indicated in the operational sections of the specifications is not implied. Exposure to absolute maximum rating conditions for extended periods may affect device reliability.*

**Electrical Characteristics**

(+3V ≤ V<sub>S</sub> ≤ +5.5V, T<sub>A</sub> = -55°C to +125°C, unless otherwise noted.)

PARAMETER	SYMBOL	CONDITIONS	MIN	TYP	MAX	UNITS
Power-Supply Voltage	V <sub>S</sub>		3.0		5.5	V
Quiescent Current	I <sub>C</sub>	I <sup>2</sup> C-compatible active			1	mA
		I <sup>2</sup> C-compatible inactive		250		μA
		Shutdown mode		1		μA
ADC Resolution		MAX6625		9		Bits
		MAX6626		12		
Temperature Resolution		MAX6625		0.5		°C/LSB
		MAX6626		0.0625		
Accuracy (Notes 2, 3)		T <sub>A</sub> = +25°C, V <sub>S</sub> = +3V to +3.6V			±1	°C
		0°C = T <sub>A</sub> ≤ +50°C, V <sub>S</sub> = +3.0V to +3.6V			±1.5	
		0°C = T <sub>A</sub> ≤ +70°C, V <sub>S</sub> = +3.0V to +3.6V			±2.0	
Power-Supply Sensitivity		V <sub>S</sub> = +3V to +5.5V		1		°C/V
Conversion Time	t <sub>C</sub>			133		ms
OT Pullup Resistor	R <sub>P</sub>	MAX6625R, MAX6626R only	25		50	kΩ
OT Saturation Voltage (Note 4)	V <sub>L</sub>	I <sub>OUT</sub> = 4mA (Note 4)			0.8	V
OT Delay		(Programmable through fault queue)	1 x t <sub>C</sub>		6 x t <sub>C</sub>	ms
T <sub>HIGH</sub> Default Temperature	T <sub>HIGH</sub>			80		°C
T <sub>LOW</sub> Default Temperature	T <sub>LOW</sub>			75		°C
<b>I<sup>2</sup>C-Compatible I/O: SCL, SDA, ADD</b>						
Input High Voltage	V <sub>IH</sub>	V <sub>S</sub> < +3.6V	2			V
		V <sub>S</sub> > +3.6V	3			
Input Low Voltage	V <sub>IL</sub>				0.8	V
Input Hysteresis				0.2		V

**Electrical Characteristics (continued)**

(+3V ≤ V<sub>S</sub> ≤ +5.5V, T<sub>A</sub> = -55°C to +125°C, unless otherwise noted.)

PARAMETER	SYMBOL	CONDITIONS	MIN	TYP	MAX	UNITS
Input High Leakage Current	I <sub>IH</sub>	V <sub>IN</sub> = +5V			±1	μA
Input Low Leakage Current	I <sub>IL</sub>	V <sub>IN</sub> = 0			±1	μA
Input Capacitance	C <sub>IN</sub>			10		pF
Output Low Voltage	V <sub>OL</sub>	I <sub>OL</sub> = 3mA			0.4	V
Output High Current	I <sub>OH</sub>	V <sub>OH</sub> = 5V			1	μA
<b>I<sup>2</sup>C-Compatible TIMING (Figure 1)</b>						
Serial Clock Frequency	f <sub>SCL</sub>		DC		400	kHz
Bus Free Time Between STOP and START Conditions	t <sub>BUF</sub>		1.3			μs
START Condition Hold Time	t <sub>HD:STA</sub>		0.6			μs
STOP Condition Setup Time	t <sub>SU:STO</sub>		0.6			μs
Clock Low Period	t <sub>LOW</sub>		1.3			μs
Clock High Period	t <sub>HIGH</sub>		0.6			μs
Data Setup Time	t <sub>SU:DAT</sub>		100			ns
Data Hold Time	t <sub>HD:DAT</sub>	(Note 5)	0		0.9	μs
Maximum Receive SCL/SDA Rise Time	t <sub>R</sub>	(Note 6)		300		ns
Minimum Receive SCL/SDA Rise Time	t <sub>R</sub>	(Note 6)		20 + 0.1C <sub>B</sub>		ns
Maximum Receive SCL/SDA Fall Time	t <sub>F</sub>	(Note 6)		300		ns
Minimum Receive SCL/SDA Fall Time	t <sub>F</sub>	(Note 6)		20 + 0.1C <sub>B</sub>		ns
Transmit SDA Fall Time	t <sub>F</sub>	C <sub>B</sub> = 400pF, I <sub>O</sub> = 3mA (Note 6)	20 + 0.1C <sub>B</sub>		250	ns
Pulse Width of Suppressed Spike	t <sub>SP</sub>	(Note 7)		50		ns

**Note 2:** Guaranteed by design and characterization to ±5 sigma.

**Note 3:** Quantization error not included in specifications for temperature accuracy.

**Note 4:** Output current should be minimized for best temperature accuracy. Power dissipation within the MAX6625/MAX6626 causes self-heating and temperature drift; see the *Thermal Considerations* section.

**Note 5:** A master device must provide a hold time of at least 300ns for the SDA signal in order to bridge the undefined region of SCL's falling edge.

**Note 6:** C<sub>B</sub> = total capacitance of one bus line in pF. Tested with C<sub>B</sub> = 400pF.

**Note 7:** Input filters on SDA, SCL, and ADD suppress noise spikes less than 50ns.

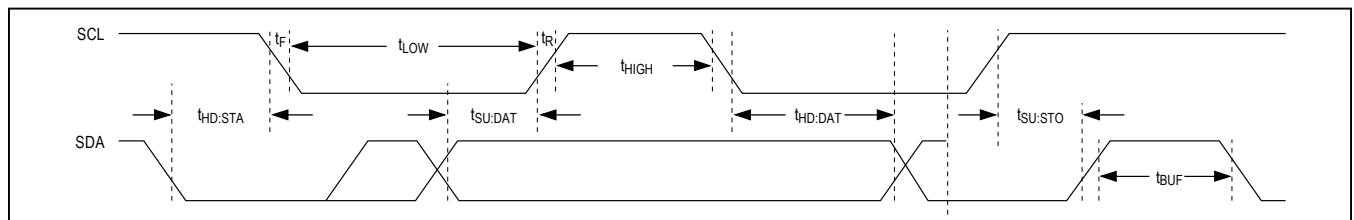
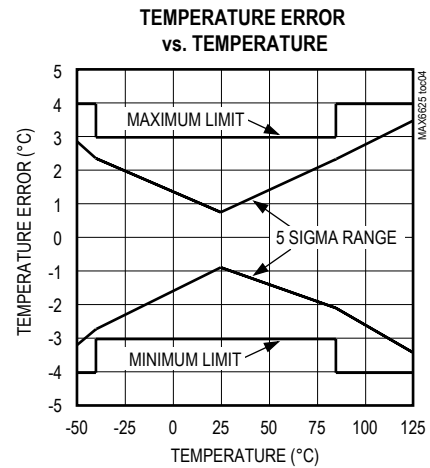
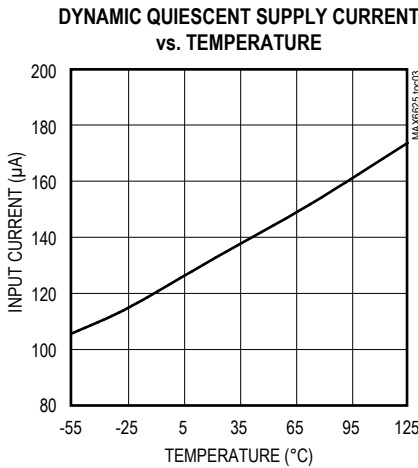
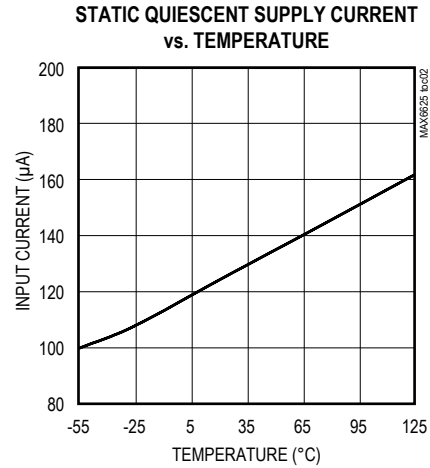
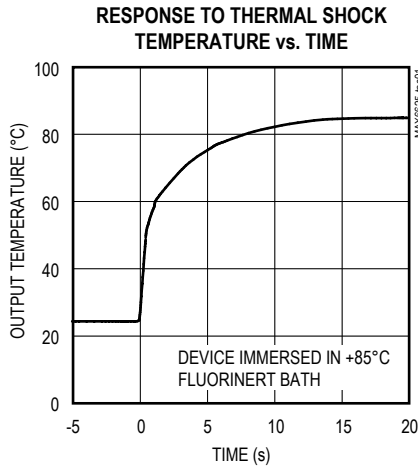

Figure 1. Serial Bus Timing

**Typical Operating Characteristics**

(V<sub>S</sub> = +3.3V, T<sub>A</sub> = +25°C, unless otherwise noted.)



**Pin Description**

PIN	NAME	FUNCTION
1	SDA	I <sup>2</sup> C-Compatible Serial Bidirectional Data Line
2	GND	Power-Supply Ground
3	SCL	I <sup>2</sup> C-Compatible Clock Input
4	OT	Temperature Alarm Output
5	ADD	I <sup>2</sup> C-Compatible Address Set Pin: Ground (0), V <sub>S</sub> (1), SDA (2), SCL (3); see Table 1.
6	V <sub>S</sub>	Power-Supply Input, +3V to +5.5V. Bypass V <sub>S</sub> to GND with a 0.1µF capacitor.
—	EP	Exposed Paddle. Internally connected to GND. Connect to a large ground plane for maximum thermal dissipation.

**Detailed Description**

The MAX6625/MAX6626 continuously convert their die temperatures into digital values using their self-contained delta-sigma ADCs. The resulting data is readable at any time through the I<sup>2</sup>C-compatible serial interface. A dedicated alarm output asserts if the result exceeds the value in the programmable high-temperature register. A programmable fault queue sets the number of faults that must occur before the alarm asserts, preventing spurious alarms in noisy environments. The alarm output polarity is selectable and deasserts based on either of two operating modes, comparator or interrupt. In comparator mode, the OT output deasserts if the temperature conversion result falls below the programmable low-temperature register value (subject to the fault queue conditions) providing adjustable hysteresis. In interrupt mode, the OT output deasserts when any register is read through the serial interface. Each conversion cycle takes about 130ms. At power-up, the temperature register is set to 8000h until the first conversion is completed.

The MAX6625/MAX6626 feature a shutdown mode, accessible through the serial interface, that saves power by turning off everything but the power-on reset and the I<sup>2</sup>C-compatible interface. While in shutdown mode, the

temperature register is set to 8000h. The device functions as a slave on the I<sup>2</sup>C-compatible bus supporting Write Byte, Write Word, Read Byte, and Read Word commands. Four separate addresses can be configured with the ADD pin, allowing up to four MAX6625/MAX6626 devices to be placed on the same bus. Figure 2 shows the functional diagram of the MAX6625/MAX6626.

**Serial interface**

**I<sup>2</sup>C-Compatible Operation**

The MAX6625/MAX6626 are readable and programmable through their I<sup>2</sup>C-compatible serial interface. Figures 3 and 4 show the timing details of the clock (SCL) and data (SDA) signals. The device functions as a slave on the I<sup>2</sup>C-compatible bus and supports Write Byte, Write Word, Read Byte, and Read Word commands.

**Addressing**

Four separate addresses can be configured with the ADD pin, allowing up to four MAX6625/MAX6626s to be placed on the same bus. The address is selected by connecting the ADD pin to either of four places: GND (address 0), V<sub>S</sub> (address 1), SDA (address 2), or SCL (address 3). Table 1 shows the full I<sup>2</sup>C-compatible address for each state.

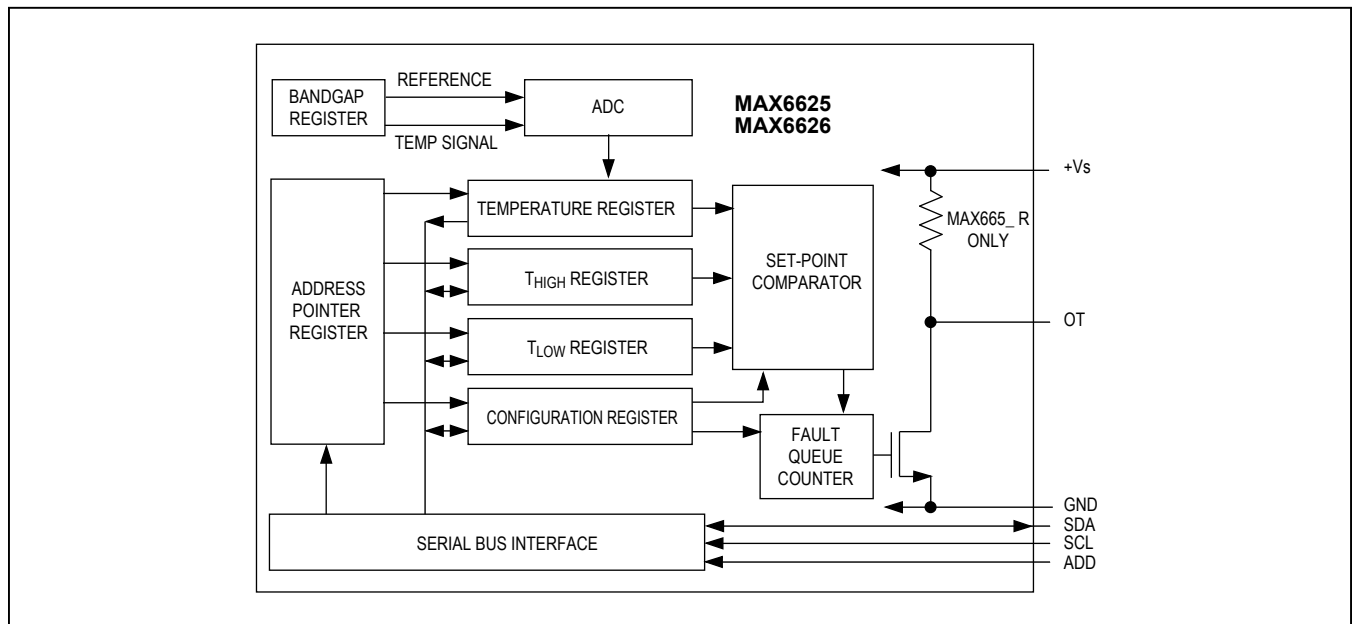

Figure 2. Functional Diagram

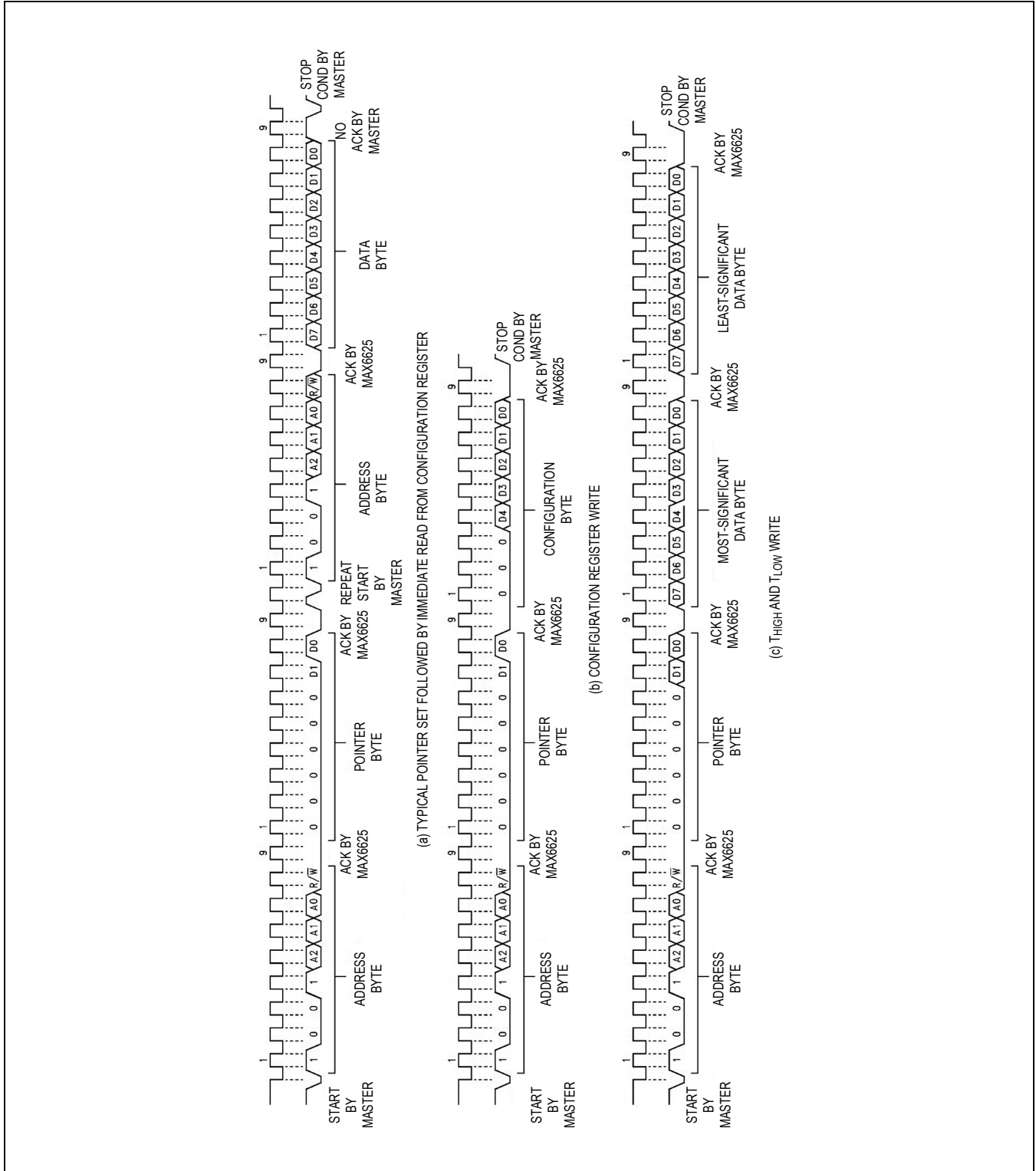

Figure 3. I<sup>2</sup>C-Compatible Timing Diagram

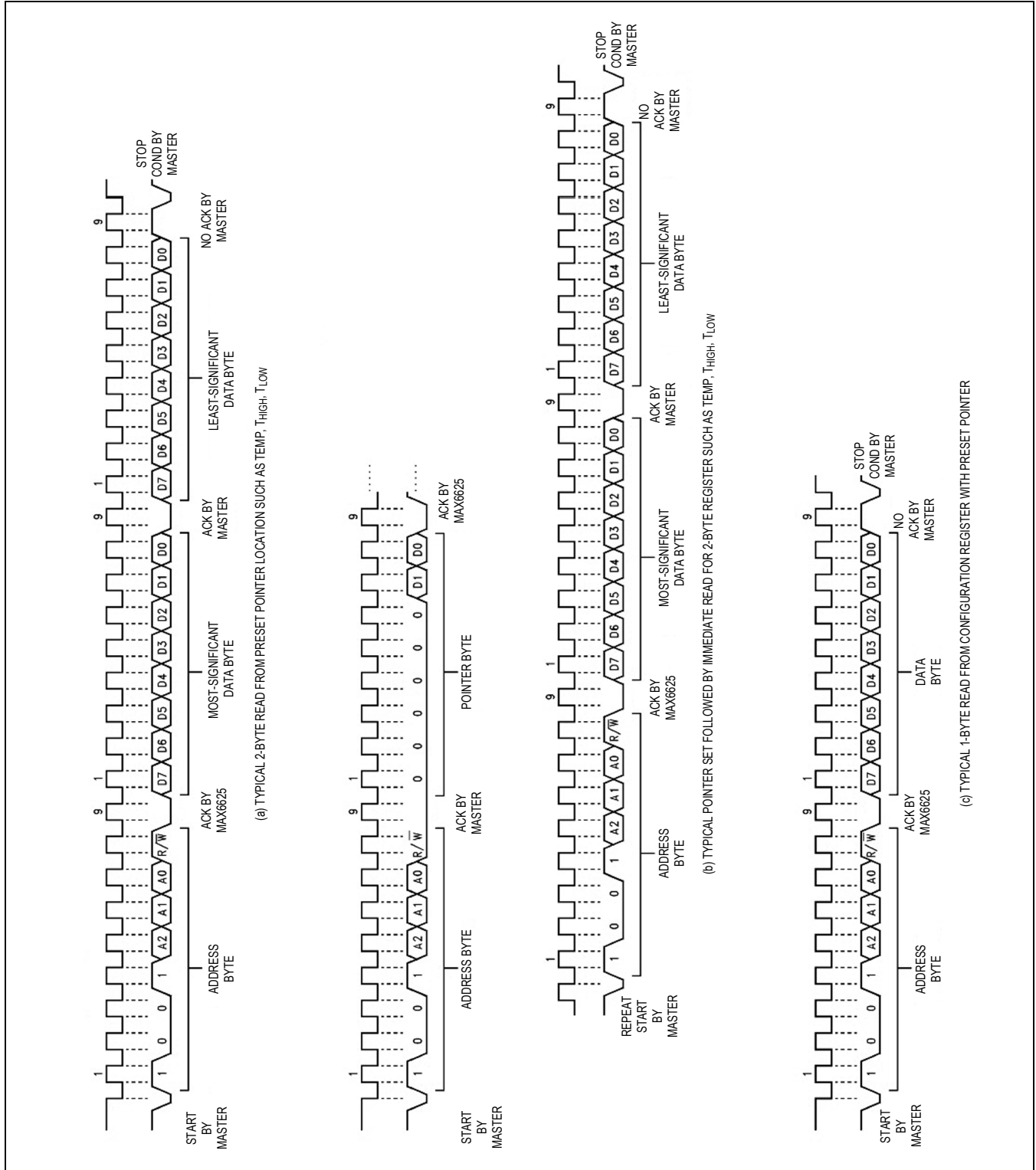

Figure 4. I<sup>2</sup>C-Compatible Timing Diagram

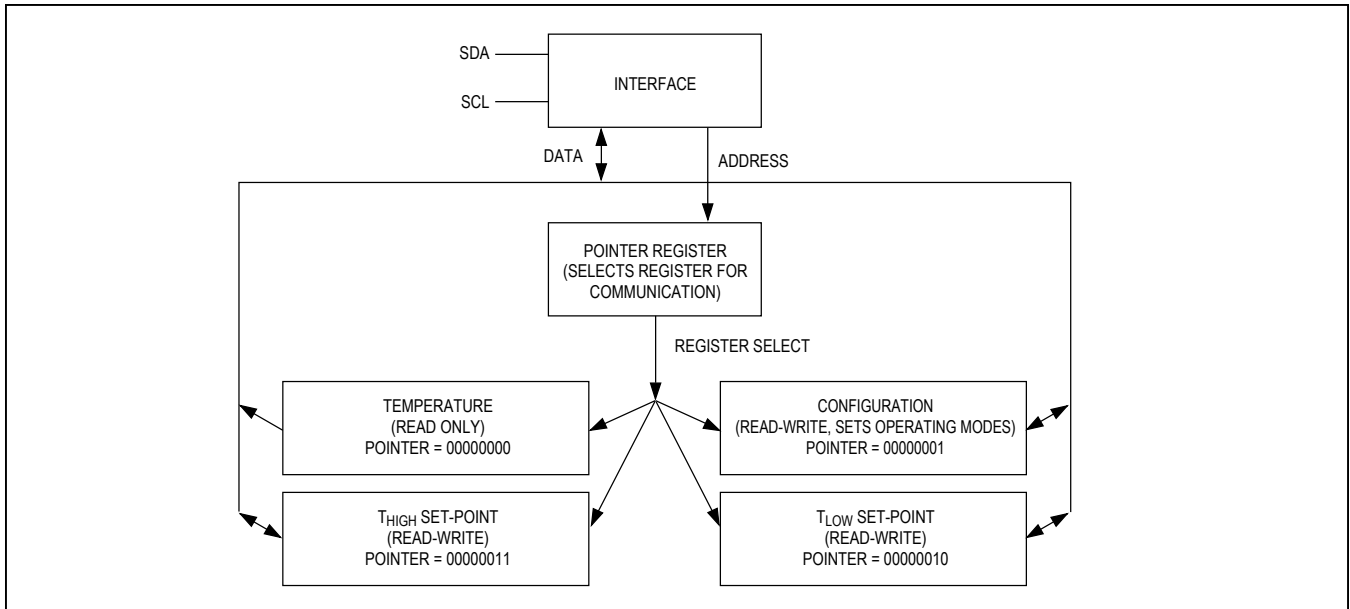

Figure 5. MAX6625/MAX6626 Programmable Model

Table 1. Address Selection

ADD CONNECTION	I <sup>2</sup> C-COMPATIBLE ADDRESS
GND	100 1000
V <sub>S</sub>	100 1001
SDA	100 1010
SCL	100 1011

**Control Registers**

Five registers control the operation of the MAX6625/MAX6626 (Figure 5 and Tables 2 through 7). The pointer register should be the first addressed and determines which of the other four registers are acted on. The other four are the temperature, configuration, high-temperature (T<sub>HIGH</sub>), and low-temperature (T<sub>LOW</sub>) registers. The temperature register is 9 bits for the MAX6625 and 12 bits for the MAX6626, read only, and contains the latest temperature data. The register length is 16 bits with the unused bits masked to zero. The digital temperature data contained in the temperature register is in °C, using a two’s-complement format with 1 LSB corresponding to 0.5°C for the MAX6625 and 0.0625°C for the MAX6626 (Table 8).

The configuration register is 8 bits, read/write, and contains the fault queue depth, the temperature alarm polarity select bit, the interrupt mode select bit, and the shutdown control bit. The high-temperature register is 9 bits, read/

write, and contains the value that triggers the overtemperature alarm. The low-temperature register is 9 bits, read/write, and contains the value to which the temperature must fall before the overtemperature alarm is deasserted, if in comparator mode.

**Temperature Conversion**

An on-chip bandgap reference produces a signal proportional to absolute temperature (PTAT), as well as the temperature-stable reference voltage necessary for the analog-to-digital conversion. The PTAT signal is digitized by the on-board ADC to a resolution of 0.5°C for the MAX6625, and 0.0625°C for the MAX6626. The resulting digital value is placed in the temperature register. The temperature conversion runs continuously and asynchronously from the I<sup>2</sup>C-compatible interface at a rate of 133ms per conversion. When the temperature register is read, the most recently completed conversion result is provided and the currently active conversion is aborted. When the bus transaction is finished by an I<sup>2</sup>C-compatible stop condition conversions resume.

**Overtemperature Alarm**

The dedicated overtemperature output pin, OT, has programmable polarity and two modes: comparator and interrupt. Polarity and mode are selected through the configuration register, and alarm activity is governed by a fault queue. Fault queue depth is also selected through the configuration register (Tables 5 and 6). The MAX6625P/MAX6626P OT output is open

**Table 2. Pointer Register**

D7	D6	D5	D4	D3	D2	D1	D0
0	0	0	0	0	0	Register select (see Table 3)	

D7 to D2: Read all zeros, cannot be written.

**Table 3. Register Select**

D1	D0	REGISTER
0	0	Temperature (default)
0	1	Configuration
1	0	T <sub>LOW</sub>
1	1	T <sub>HIGH</sub>

**Table 4. Temperature Register**

PART	D15	D14	D13	D12	D11	D10	D9	D8	D7	D6	D5	D4	D3–D0
MAX6625	MSB (Sign)	Bit 7	Bit 6	Bit 5	Bit 4	Bit 3	Bit 2	Bit 1	LSB	0	0	0	0
MAX6626	MSB (Sign)	Bit 10	Bit 9	Bit 8	Bit 7	Bit 6	Bit 5	Bit 4	Bit 3	Bit 2	Bit 1	LSB	0

D6 to D0, MAX6625: Read all zeros, cannot be written.  
 D3 to D0, MAX6626: Read all zeros, cannot be written.  
 D15: MSB is the sign bit.

1 LSB = 0.5°C for the MAX6625.  
 1 LSB = 0.0625°C for the MAX6626.  
 Temperature is stored in two's-complement format.

**Table 5. Configuration Register**

D7	D6	D5	D4	D3	D2	D1	D0
0	0	0	Fault Queue Depth	OT Polarity	Comparator or Interrupt Mode	Shutdown	

All defaults = 0.  
 D0: 0 = Normal operation, 1 = Shutdown.  
 D1: 0 = Comparator mode, 1 = Interrupt mode.  
 D2: 0 = Active low, 1 = Active high.  
 D7 to D5: Reserved locations, always write zeros.

**Table 6. Fault Queue Depth**

D4	D3	NO. OF FAULTS
0	0	1 (default)
0	1	2
1	0	4
1	1	6

**Table 7. T<sub>HIGH</sub> and T<sub>LOW</sub> Registers**

D15	D14	D13	D12	D11	D10	D9	D8	D7	D6	D5	D4	D3	D2	D1	D0
MSB	Bit 7	Bit 6	Bit 5	Bit 4	Bit 3	Bit 2	Bit 1	LSB	0	0	0	0	0	0	0

D6 to D0: Read all zeros, cannot be written.

D15: MSB is the sign bit.

Default: T<sub>HIGH</sub> = +80°C (5000h), T<sub>LOW</sub> = +75°C (4B00h).

LSB = 0.5°C.

**Table 8. Output Code vs. Temperature**

TEMPERATURE (°C)	DIGITAL OUTPUT CODE					
	MAX6625			MAX6626		
	BINARY		HEX	BINARY		HEX
	MSB	LSB		MSB	LSB	
+125.0000	0111 1101 0000 0000		7D00	0111 1101 0000 0000		7D00
+124.9375	0111 1100 1000 0000		7C80	0111 1100 1111 0000		7CF0
+25.0000	0001 1001 0000 0000		1900	0001 1001 0000 0000		1900
+0.5000	0000 0000 1000 0000		0080	0000 0000 1000 0000		0080
0.0000	0000 0000 0000 0000		0000	0000 0000 0000 0000		0000
-0.5000	1111 1111 1000 0000		FF80	1111 1111 1000 0000		FF80
-25.0000	1110 0111 0000 0000		E700	1110 0111 0000 0000		E700
-55.0000	1100 1001 0000 0000		C900	1100 1001 0000 0000		C900
*	1000 0000 0000 0000		8000	1000 0000 0000 0000		8000

\*8000h is the default value at power-up and after coming out of shutdown.

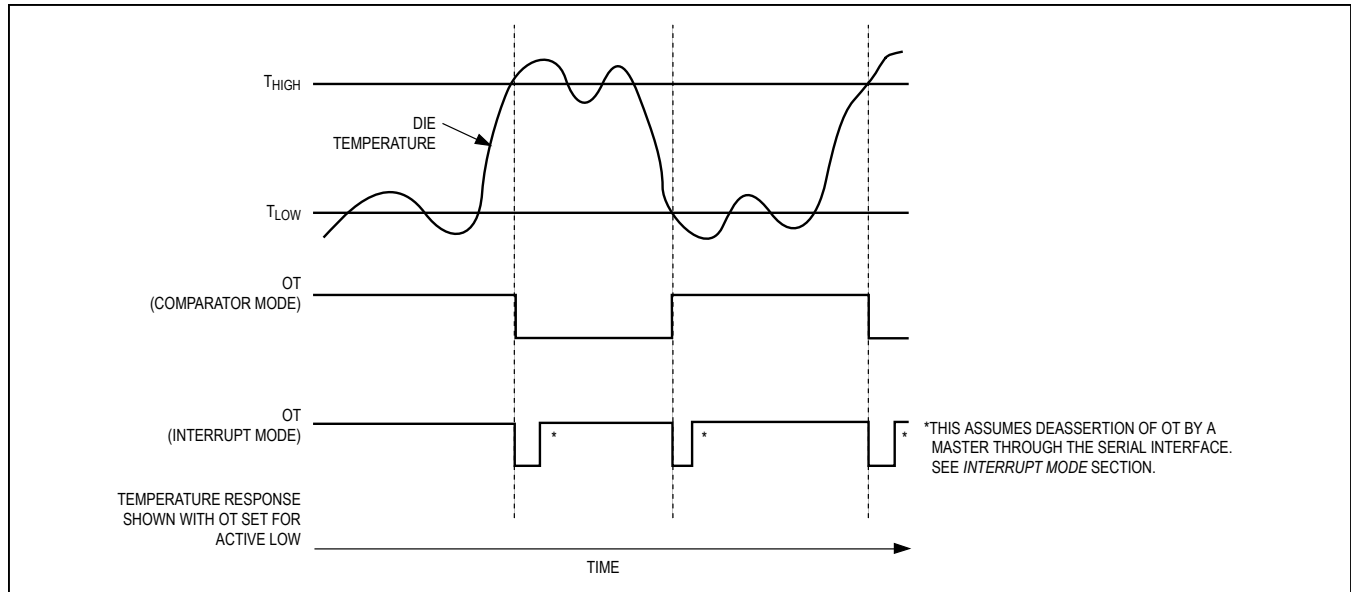

Figure 6. OT Alarm Output and Reset Diagram

drain, and the MAX6625R/MAX6626R output includes an internal 35k $\Omega$  (typ) pullup resistor. Figure 6 shows the OT alarm operation and reset details.

### Fault Queue

A programmable fault queue on the MAX6625/MAX6626 eliminates spurious alarm activity in noisy environments. The queue sets the number of consecutive out-of-tolerance temperature readings that must occur before the OT alarm output is toggled. An out-of-tolerance reading is above  $T_{HIGH}$  or below  $T_{LOW}$ . The fault queue depth defaults to one at power-up and may be programmed to one, two, four, or six consecutive conversions. Any time the conversion result is in tolerance, and OT is not asserted, the queue is cleared, even if it contains some out-of-tolerance counts. Additionally, the fault queue automatically clears at power-up, in shutdown, or if a master writes to any of the  $T_{HIGH}$ ,  $T_{LOW}$ , or configuration registers. Whenever the fault queue is cleared, OT is deasserted.

For example, the fault queue is set to four, two consecutive out-of-tolerance readings have occurred, and the master writes to the  $T_{LOW}$  register. The fault queue is cleared and begins to look for four new consecutive out-of-tolerance conversions.

### Comparator Mode

In comparator mode, OT is asserted when the number of consecutive conversions exceeding the value in the  $T_{HIGH}$  register is equal to the depth of the fault queue. OT

deasserts when the number of consecutive conversions less than the value in the  $T_{LOW}$  register is equal to the depth of the fault queue.  $T_{HIGH}$  minus  $T_{LOW}$  is the effective hysteresis of the OT output.

For example, if  $T_{HIGH}$  is set to +100°C,  $T_{LOW}$  is set to +80°C, and the fault queue depth is set to four, OT does not assert until four consecutive conversions exceed +100°C. Then, OT does not deassert until four consecutive conversions are less than +80°C.

Comparator mode allows autonomous clearing of an OT fault without the intervention of a master and is ideal to use for driving a cooling fan (Figure 7).

### Interrupt Mode

In interrupt mode, the MAX6625/MAX6626 look for a  $T_{HIGH}$  or a  $T_{LOW}$  fault based on previous fault activity. The OT pin asserts an alarm for an undertemperature fault, as well as for an overtemperature fault, depending on certain conditions. If the fault queue is cleared at power-up, the IC looks for a  $T_{HIGH}$  fault. After a  $T_{HIGH}$  fault, the IC looks for a  $T_{LOW}$  fault. After a  $T_{LOW}$  fault, the IC looks for a  $T_{HIGH}$  fault, and it bounces back and forth if properly deasserted each time. Once either fault has occurred, it remains active indefinitely until deasserted by a read of any register, and the device then begins to look for a fault of the opposite type. Also, if the fault queue is cleared, OT is deasserted and the IC once again looks for a  $T_{HIGH}$  fault. The activation of any fault is subject to the depth of the fault queue.

Example 1: If T<sub>HIGH</sub> is set to +100°C, T<sub>LOW</sub> is set to +80°C, and the fault queue depth is set to four, OT does not assert until four consecutive conversions exceed +100°C. If the temperature is then read through the I<sup>2</sup>C-compatible interface, OT deasserts. OT asserts again when four consecutive conversions are less than +80°C.

Example 2: If T<sub>HIGH</sub> is set to +100°C, T<sub>LOW</sub> is set to +80°C, and the fault queue depth is set to four, OT does not assert until four consecutive conversions exceed +100°C. If the T<sub>HIGH</sub> register is then changed to +120°C, OT deasserts and the IC looks for a new T<sub>HIGH</sub> fault.

**Shutdown**

The MAX6625/MAX6626 offer a low-power shutdown mode. Enter shutdown mode by programming the shutdown bit of the control register high. In shutdown, the temperature register is set to 8000h and the ADC is turned off, reducing the device current draw to 1µA (typ). After coming out of shutdown, the temperature register continues to read 8000h until the first conversion result appears. The fault queue is held in reset during shutdown.

**Thermal Considerations**

The MAX6625/MAX6626 supply current is less than 1mA when the I<sup>2</sup>C-compatible interface is active. When used to drive high-impedance loads, the devices dissipate negligible power; therefore, the die temperature is essentially the same as the package temperature.

The key to accurate temperature monitoring is good thermal contact between the MAX6625/MAX6626 package and the monitored device or circuit. In some applications, the 6-pin SOT23 package may be small enough to fit underneath a socketed µP, allowing the device to monitor the µP's temperature directly. Heat flows in and out of plastic packages primarily through the leads. Short, wide copper traces leading to the temperature monitor ensure that heat transfers quickly and reliably. The rise in die temperature due to self-heating is given by the following formula:

$$\Delta T_J = P_D \times \theta_{JA}$$

where P<sub>D</sub> is the power dissipated by the MAX6625/MAX6626, and θ<sub>JA</sub> is the package's thermal resistance.

The typical thermal resistance is +110°C/W for the 6-pin SOT23 package. To limit the effects of self-heating, minimize the output currents. For example, if the MAX6625/MAX6626 sink 4mA with the maximum OT V<sub>L</sub> specification of 0.8V, an additional 3.2mW of power is dissipated within the IC. This corresponds to a 0.35°C rise in the die temperature.

**Applications**

Figure 7 shows the MAX6625/MAX6626 used as a temperature-triggered fan controller. Figure 8 shows the MAX6625/MAX6626 used as a thermostat to control a heating element.

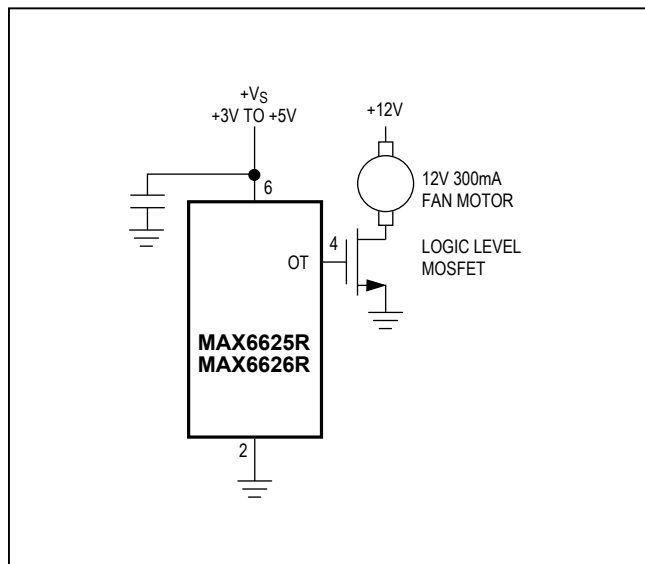

Figure 7. Fan Controller

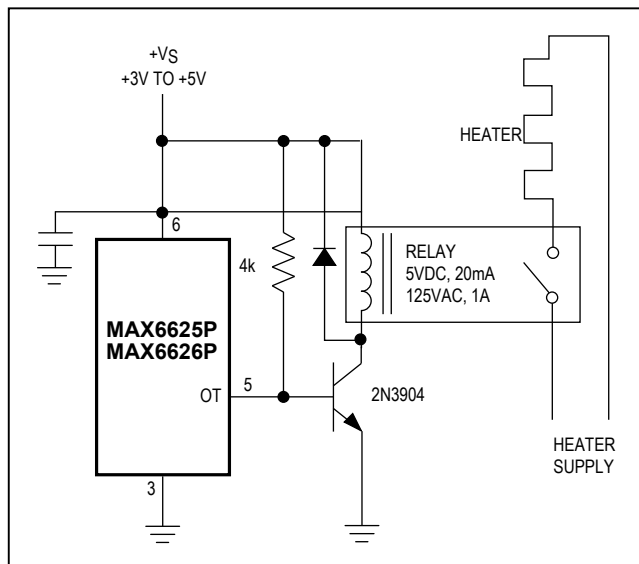

Figure 8. Simple Thermostat

## Selector Guide

PART	ALARM OUTPUT	RESOLUTION (BITS)	TOP MARK
MAX6625PMUT	Open-Drain	9	AAHY
MAX6625RMUT	Internal Pullup	9	AAHZ
MAX6626PMUT	Open-Drain	12	AANP
MAX6626RMUT	Internal Pullup	12	AANQ

## Ordering Information(continued)

PART	TEMP RANGE	PIN-PACKAGE
<b>MAX6625RMUT#G16</b>	-55°C to +125°C	6 SOT23
MAX6625PMUT#G16	-55°C to +125°C	6 SOT23
MAX6625RMUT#TG16	-55°C to +125°C	6 SOT23
MAX6625PMUT#TG16	-55°C to +125°C	6 SOT23
<b>MAX6626PMUT#G16</b>	-55°C to +125°C	6 SOT23
MAX6626RMUT#G16	-55°C to +125°C	6 SOT23
MAX6626PMUT#TG16	-55°C to +125°C	6 SOT23
MAX6626RMUT#TG16	-55°C to +125°C	6 SOT23

**\*For device options, see Selector Guide at end of data sheet.**  
Requires special solder temperature profile described in the Absolute Maximum Ratings section.

\*\*EP = Exposed pad.

# Indicates an RoHS-compliant part

## Chip Information

PROCESS: BiCMOS

## Package Information

For the latest package outline information and land patterns (footprints), go to [www.maximintegrated.com/packages](http://www.maximintegrated.com/packages). Note that a "+", "#", or "-" in the package code indicates RoHS status only. Package drawings may show a different suffix character, but the drawing pertains to the package regardless of RoHS status.

PACKAGE TYPE	PACKAGE CODE	OUTLINE NO.	LAND PATTERN NO.
6 SOT23	U6F-6	<a href="#">21-0058</a>	<a href="#">90-0175</a>
6 SOT23	U6FH-6***	<a href="#">21-0058</a>	<a href="#">90-0175</a>
6 TDFN-EP	T633-1	<a href="#">21-0137</a>	<a href="#">90-0058</a>

\*\*\* Package code for RoHS-Compliant parts

## Revision History



REVISION NUMBER	REVISION DATE	DESCRIPTION	PAGES CHANGED
5	11/12	Updated Table 4 and corrected hexadecimal formatting	5, 9, 10, 12
6	11/14	Updated the <i>Selector Guide</i>	13
7	6/16	Updated <i>Ordering Information</i> and <i>Package Information</i> tables	1, 13

For pricing, delivery, and ordering information, please contact Maxim Direct at 1-888-629-4642, or visit Maxim Integrated's website at [www.maximintegrated.com](http://www.maximintegrated.com).

Maxim Integrated cannot assume responsibility for use of any circuitry other than circuitry entirely embodied in a Maxim Integrated product. No circuit patent licenses are implied. Maxim Integrated reserves the right to change the circuitry and specifications without notice at any time. The parametric values (min and max limits) shown in the Electrical Characteristics table are guaranteed. Other parametric values quoted in this data sheet are provided for guidance.

## Looking for pricing, stock, or lifecycle information?

Click below to explore more details on WIN SOURCE:

-  [View MAX6626RMUT-T on WIN SOURCE](#)
-  [Maxim Integrated](#) Information

## Optimize Your Supply Chain with WIN SOURCE Solutions

-  Global Sourcing Solution
-  Obsolete Management
-  Cost Control Management
-  Shortage Management
-  Alternative Solution
-  Excess Inventory Management