



**THE DATASHEET OF
MAX6391KA29+T**





Dual-Voltage μ P Supervisory Circuits with Sequenced Reset Outputs

MAX6391/MAX6392

General Description

The MAX6391/MAX6392 microprocessor (μ P) supervisory circuits provide sequenced logic reset outputs for multi-component or dual-voltage systems. Each device can monitor two supply voltages and time-sequence two reset outputs to control the order in which system components are turned on and off. The MAX6391/MAX6392 increase system reliability and reduce circuit complexity and cost compared to separate ICs or discrete components.

The MAX6391/MAX6392 monitor V_{CC} as the master reset supply. Both $\overline{\text{RESET1}}$ and $\overline{\text{RESET2}}$ are asserted whenever V_{CC} drops below the selected factory-fixed reset threshold voltage. $\overline{\text{RESET1}}$ remains asserted as long as V_{CC} is below the threshold and deasserts 140ms (min) after V_{CC} exceeds the thresholds.

$\overline{\text{RESET IN2}}$ is monitored as the secondary reset supply and is adjustable with an external resistive-divider network. $\overline{\text{RESET2}}$ is asserted whenever either V_{CC} or $\overline{\text{RESET IN2}}$ is below the selected thresholds. $\overline{\text{RESET2}}$ remains asserted 140ms (min) or a capacitor-adjustable time period after V_{CC} and $\overline{\text{RESET IN2}}$ exceed their thresholds. $\overline{\text{RESET2}}$ is always deasserted after $\overline{\text{RESET1}}$ during system power-up and is always asserted before $\overline{\text{RESET1}}$ during power-down.

The MAX6391 includes two internal pullup resistors for $\overline{\text{RESET1}}$ and $\overline{\text{RESET2}}$ (the open-drain outputs can be externally connected to the desired pullup voltages). The MAX6392 includes an active-low manual reset input (MR) that asserts both $\overline{\text{RESET1}}$ (push-pull) and $\overline{\text{RESET2}}$ (open drain).

The MAX6391/MAX6392 are available in small 8-pin SOT23 packages and are specified over the -40°C to $+85^{\circ}\text{C}$ extended temperature range.

Applications

- Computers
- Controllers
- Critical μ P Power Monitoring
- Set-Top Boxes
- Printers
- Servers/Workstations
- Industrial Equipment
- Multivoltage Monitoring

Typical Operating Circuit appears at end of data sheet.

Features

- ◆ Preset V_{CC} Reset Threshold Voltages from 1.58V to 4.63V (master supply)
- ◆ Customer-Adjustable $\overline{\text{RESET IN2}}$ to Monitor Voltages Down to 625mV (secondary supply)
- ◆ Fixed (140ms min) $\overline{\text{RESET1}}$ Timeout
- ◆ Fixed (140ms min) or Customer-Adjustable $\overline{\text{RESET2}}$ Timeout Period
- ◆ Guaranteed Reset Valid to $V_{CC} = 1\text{V}$
- ◆ Active-Low Open-Drain Outputs or Push-Pull/Open-Drain Combination
- ◆ Internal Open-Drain Pullup Resistors (for external V_{OH} voltage connections)
- ◆ Manual Reset Input (MAX6392 only)
- ◆ Immune to Short Negative V_{CC} Transients
- ◆ 15 μA Typical Supply Current
- ◆ Few External Components
- ◆ Small 8-Pin SOT23 Package

Ordering Information

PART*	TEMP RANGE	PIN-PACKAGE
MAX6391KA__-T	-40°C to $+85^{\circ}\text{C}$	SOT23-8
MAX6392KA__-T	-40°C to $+85^{\circ}\text{C}$	SOT23-8

*Insert the desired suffix (see Selector Guide) into the blanks to complete the part number. The MAX6391/MAX6392 require a 2.5k minimum order increment and are available in tape-and-reel only. Samples are typically available for standard versions (see Selector Guide for standard versions). Contact factory for availability.

Devices are available in both leaded and lead-free packaging. Specify lead-free by replacing "-T" with "+T" when ordering.

Pin Configurations

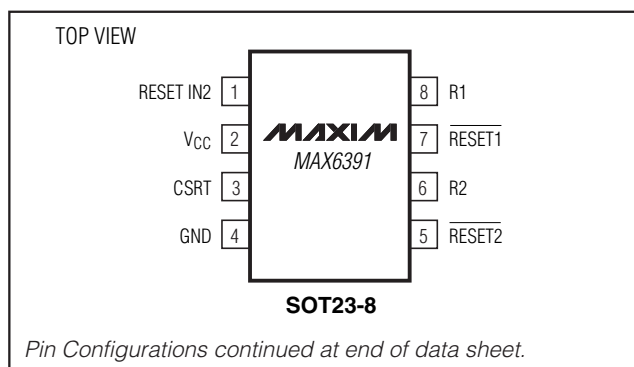

Dual-Voltage μ P Supervisory Circuits with Sequenced Reset Outputs

ABSOLUTE MAXIMUM RATINGS

V_{CC} to GND-0.3V to +6.0V
 $\overline{\text{RESET1}}$ (MAX6392), RESET IN2, CSRT,
 $\overline{\text{MR}}$ to GND-0.3V to ($V_{CC} + 0.3$ V)
 $\overline{\text{RESET1}}$ (MAX6391), $\overline{\text{RESET2}}$, R1, R2 to GND.....-0.3V to +6.0V
 Input Current (V_{CC} , GND, CSRT, R1, R2, $\overline{\text{MR}}$) ± 20 mA
 Output Current ($\overline{\text{RESET1}}$, $\overline{\text{RESET2}}$) ± 20 mA
 Continuous Power Dissipation ($T_A = +70^\circ\text{C}$)
 8-Pin SOT23 (derate 5.26mW/ $^\circ\text{C}$ above $+70^\circ\text{C}$).....421mW

Operating Temperature Range-40 $^\circ\text{C}$ to +85 $^\circ\text{C}$
 Junction Temperature+150 $^\circ\text{C}$
 Storage Temperature Range-65 $^\circ\text{C}$ to +150 $^\circ\text{C}$
 Lead Temperature (soldering, 10s)+300 $^\circ\text{C}$

Stresses beyond those listed under "Absolute Maximum Ratings" may cause permanent damage to the device. These are stress ratings only, and functional operation of the device at these or any other conditions beyond those indicated in the operational sections of the specifications is not implied. Exposure to absolute maximum rating conditions for extended periods may affect device reliability.

ELECTRICAL CHARACTERISTICS

($V_{CC} = 1.2\text{V}$ to 5.5V , $T_A = T_{MIN}$ to T_{MAX} , unless otherwise specified. Typical values are at $V_{CC} = +5\text{V}$ and $T_A = +25^\circ\text{C}$.) (Note 1)

PARAMETER	SYMBOL	CONDITIONS	MIN	TYP	MAX	UNITS
V_{CC} Range		$T_A = 0^\circ\text{C}$ to $+85^\circ\text{C}$	1.0		5.5	V
		$T_A = -40^\circ\text{C}$ to $+85^\circ\text{C}$	1.2		5.5	
Supply Current	I_{CC}	No load		15	25	μA
V_{CC} Reset Threshold	V_{TH1}	MAX639_UA46	4.50	4.63	4.75	V
		MAX639_UA44	4.25	4.38	4.50	
		MAX639_UA31	3.00	3.08	3.15	
		MAX639_UA29	2.85	2.93	3.00	
		MAX639_UA26	2.55	2.63	2.70	
		MAX639_UA23	2.25	2.32	2.38	
		MAX639_UA22	2.12	2.19	2.25	
		MAX639_UA17	1.62	1.67	1.71	
MAX639_UA16	1.54	1.58	1.61			
RESET IN2 Threshold	V_{TH2}	$V_{CC} = 5\text{V}$	610	625	640	mV
RESET IN2 Input Current					50	nA
V_{CC} to $\overline{\text{RESET1}}$ Delay	t_{RD1}	V_{CC} falling at $1\text{mV}/\mu\text{s}$ (Note 2)		20		μs
V_{CC} or RESET IN2 to $\overline{\text{RESET2}}$ Delay	t_{RD2}			10		

Dual-Voltage μ P Supervisory Circuits with Sequenced Reset Outputs

MAX6391/MAX6392

ELECTRICAL CHARACTERISTICS (continued)

($V_{CC} = 1.2V$ to $5.5V$, $T_A = T_{MIN}$ to T_{MAX} , unless otherwise specified. Typical values are at $V_{CC} = +5V$ and $T_A = +25^\circ C$.) (Note 1)

PARAMETER	SYMBOL	CONDITIONS	MIN	TYP	MAX	UNITS
$\overline{RESET1}$ Timeout Period	t_{RP1}		140	200	280	ms
$\overline{RESET2}$ Timeout Period (Note 3)	t_{RP2}	$C_{CSRT} = 1500pF$	2.2	3.1	4.0	ms
		$C_{CSRT} = V_{CC}$	140	200	280	
$\overline{RESET_}$ Output Voltage Low	V_{OL}	$I_{SINK} = 50\mu A$, reset asserted	$V_{CC} \geq 1.0V$, $T_A = 0^\circ C$ to $+85^\circ C$		0.3	V
			$V_{CC} \geq 1.2V$, $T_A = -40^\circ C$ to $+85^\circ C$		0.3	
		$I_{SINK} = 1.2mA$, reset asserted, $V_{CC} \geq 2.5V$		0.3		
		$I_{SINK} = 3.2mA$, reset asserted, $V_{CC} \geq 4.25V$		0.4		
Open-Drain \overline{RESET} Output Leakage Current	I_{LKG}	$V_{CC} \geq V_{TH1}$, $V_{RESET IN2} \geq V_{TH2}$, reset not asserted			1.0	μA
Push-Pull $\overline{RESET1}$ Output Voltage High (MAX6392 only)	V_{OH}	$V_{CC} \geq 2.25V$, $I_{SOURCE} = 500\mu A$, reset not asserted			$0.8 \times V_{CC}$	V
		$V_{CC} \geq 4.5V$, $I_{SOURCE} = 800\mu A$, reset not asserted				
\overline{MR} Input	V_{IL}	$V_{CC} > 4.0V$			0.8	V
	V_{IH}		2.4			
	V_{IL}	$V_{CC} < 4.0V$			$0.3 \times V_{CC}$	
	V_{IH}		$0.7 \times V_{CC}$			
\overline{MR} Minimum Pulse Width			50			μs
\overline{MR} Glitch Rejection				100		ns
\overline{MR} to $\overline{RESET1}$ Delay	t_{MR1}			10		μs
\overline{MR} to $\overline{RESET2}$ Delay	t_{MR2}			100		ns
t_{MR} Skew		$t_{MR1} - t_{MR2}$		10		μs
\overline{MR} Pullup Resistance		Pullup to V_{CC}	35	47	60	$k\Omega$
Reset Pullup Resistance		$\overline{RESET1}$ to R1 or $\overline{RESET2}$ to R2	35	47	60	$k\Omega$

Note 1: Overtemperature limits are guaranteed by design and not production tested. Devices tested at $+25^\circ C$ only.

Note 2: $\overline{RESET2}$ asserts before $\overline{RESET1}$ when V_{CC} goes below the threshold for all supply voltage and temperature ranges.

Note 3: CSRT must be connected to either V_{CC} (for fixed $\overline{RESET2}$ timeout period) or an external capacitor (for user-adjustable $\overline{RESET2}$ timeout period).

Dual-Voltage μ P Supervisory Circuits with Sequenced Reset Outputs

Typical Operating Characteristics

($V_{CC} = +5V$, $T_A = +25^\circ C$, unless otherwise noted.)

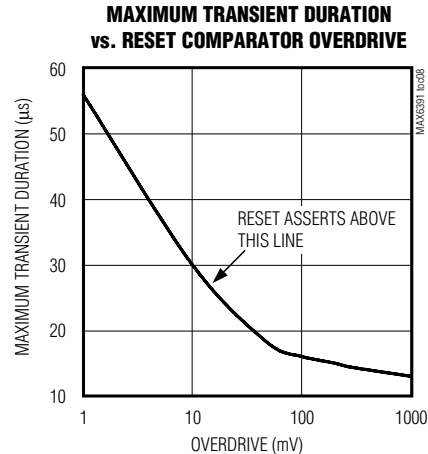
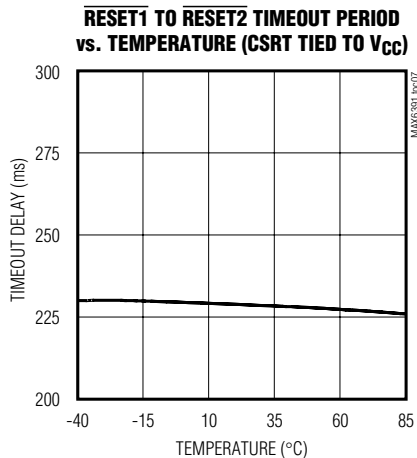
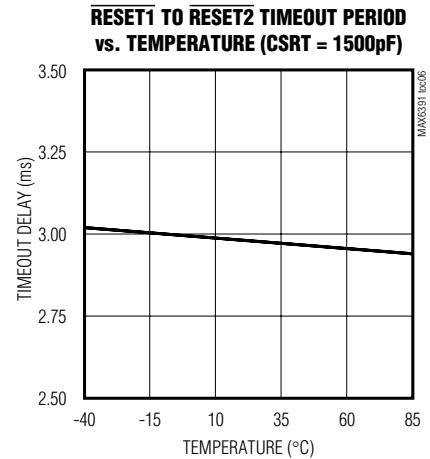
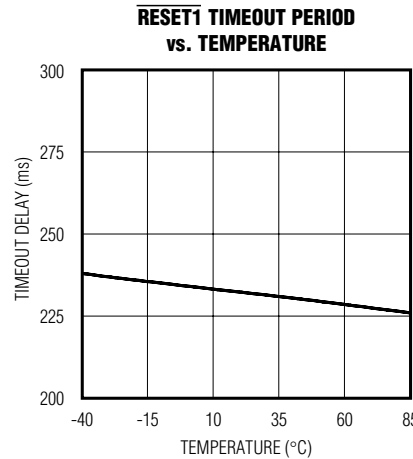
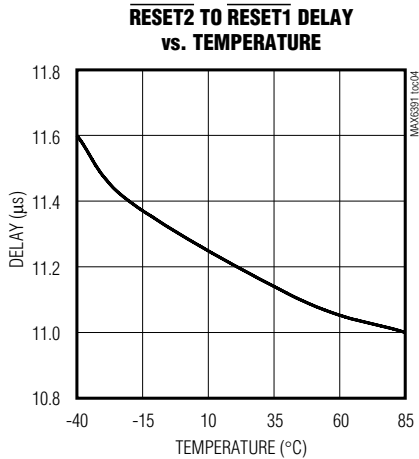
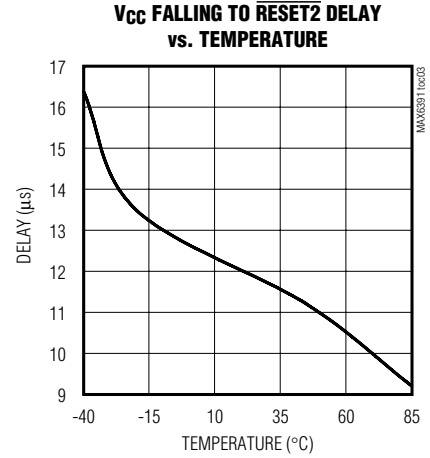
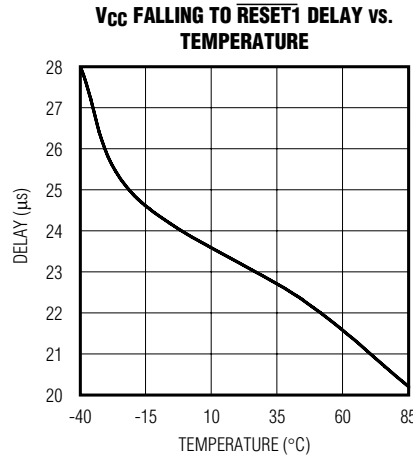
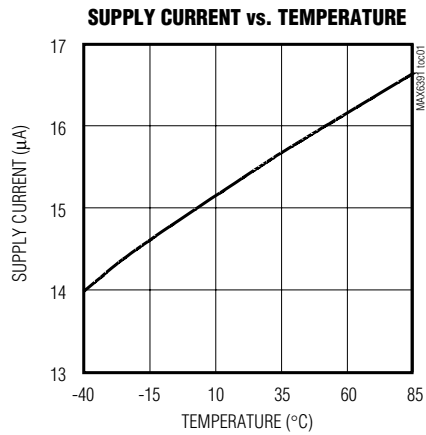

Dual-Voltage μ P Supervisory Circuits with Sequenced Reset Outputs

Pin Description

MAX6391/MAX6392

PIN		NAME	FUNCTION
MAX6391	MAX6392		
1	1	RESET IN2	Input Voltage for $\overline{\text{RESET2}}$ Monitor. High-impedance input for internal reset comparator. Connect this pin to an external resistive-divider network to set the reset threshold voltage.
2	2	V _{CC}	Supply Voltage and Input Voltage for Primary Supply Monitor
3	3	CSRT	$\overline{\text{RESET2}}$ Delay Set Capacitor. Connect to V _{CC} for a fixed 140ms (min) timeout period or to an external capacitor for a user-adjustable timeout period after V _{CC} exceeds its minimum threshold.
4	4	GND	Ground
5	5	$\overline{\text{RESET2}}$	Secondary Reset Output, Open-Drain, Active-Low. $\overline{\text{RESET2}}$ changes from high to low when either V _{CC} or RESET IN2 drop below their thresholds. $\overline{\text{RESET2}}$ remains low for a user-adjustable timeout period (see CSRT) or a fixed 140ms (min) after V _{CC} and RESET IN2 meet their minimum thresholds.
6	6	R2	47k Ω Internal Pullup Resistor for $\overline{\text{RESET2}}$. Connect to external voltage for $\overline{\text{RESET2}}$ high pullup.
7	7	$\overline{\text{RESET1}}$	Primary Reset Output, Open-Drain (MAX6391) or Push-Pull (MAX6392), Active-Low. $\overline{\text{RESET1}}$ changes from HIGH to LOW when the V _{CC} input drops below the selected reset threshold. $\overline{\text{RESET1}}$ remains LOW for the reset timeout period after V _{CC} exceeds the minimum threshold.
8	—	R1	47k Ω Internal Pullup Resistor for $\overline{\text{RESET1}}$. Connect to external voltage for $\overline{\text{RESET1}}$ high pullup.
—	8	$\overline{\text{MR}}$	Manual Reset, Active-Low, Internal 47k Ω Pullup to V _{CC} . Pull LOW to force a reset. $\overline{\text{RESET1}}$ and $\overline{\text{RESET2}}$ remain asserted as long as $\overline{\text{MR}}$ is LOW and for the $\overline{\text{RESET1}}$ and $\overline{\text{RESET2}}$ timeout periods after $\overline{\text{MR}}$ goes HIGH. Leave unconnected or connect to V _{CC} if unused.

Detailed Description

Each device includes a pair of voltage monitors with sequenced reset outputs. The first block monitors V_{CC} only ($\overline{\text{RESET1}}$ output is independent of the RESET IN2 monitor). It asserts a reset signal (LOW) whenever V_{CC} is below the preset voltage threshold. $\overline{\text{RESET1}}$ remains asserted for at least 140ms after V_{CC} rises above the reset threshold. $\overline{\text{RESET1}}$ timing is internally set in each device. V_{CC} voltage thresholds are available from 1.57V to 4.63V. In all cases V_{CC} acts as the master supply (all resets are asserted when V_{CC} goes below its selected threshold). The V_{CC} input also acts as the device power supply.

The second block monitors both RESET IN2 and V_{CC}. It asserts a reset signal (LOW) whenever RESET IN2 is below the 625mV threshold or V_{CC} is below its reset threshold. $\overline{\text{RESET2}}$ remains asserted for a fixed 140ms

(min) or a user-adjustable time period after RESET IN2 rises above the 625mV reset threshold and $\overline{\text{RESET1}}$ is deasserted. Resets are guaranteed valid for V_{CC} down to 1V.

The timing diagram in Figure 2 shows the reset timing characteristics of the MAX6391/MAX6392. As shown in Figure 2, $\overline{\text{RESET1}}$ deasserts 140ms (min) (t_{RP1}) after V_{CC} exceeds the reset threshold. $\overline{\text{RESET2}}$ deasserts t_{RP2} (140ms minimum or a user-adjustable timeout period) after RESET IN2 exceeds 625mV and $\overline{\text{RESET1}}$ is deasserted. When RESET IN2 drops below 625mV while V_{CC} is above the reset threshold, $\overline{\text{RESET2}}$ asserts within 10 μ s typ. $\overline{\text{RESET1}}$ is unaffected when this happens. When V_{CC} falls below V_{TH1}, $\overline{\text{RESET2}}$ always asserts before $\overline{\text{RESET1}}$ ($t_{RD2} < t_{RD1}$).

Dual-Voltage μ P Supervisory Circuits with Sequenced Reset Outputs

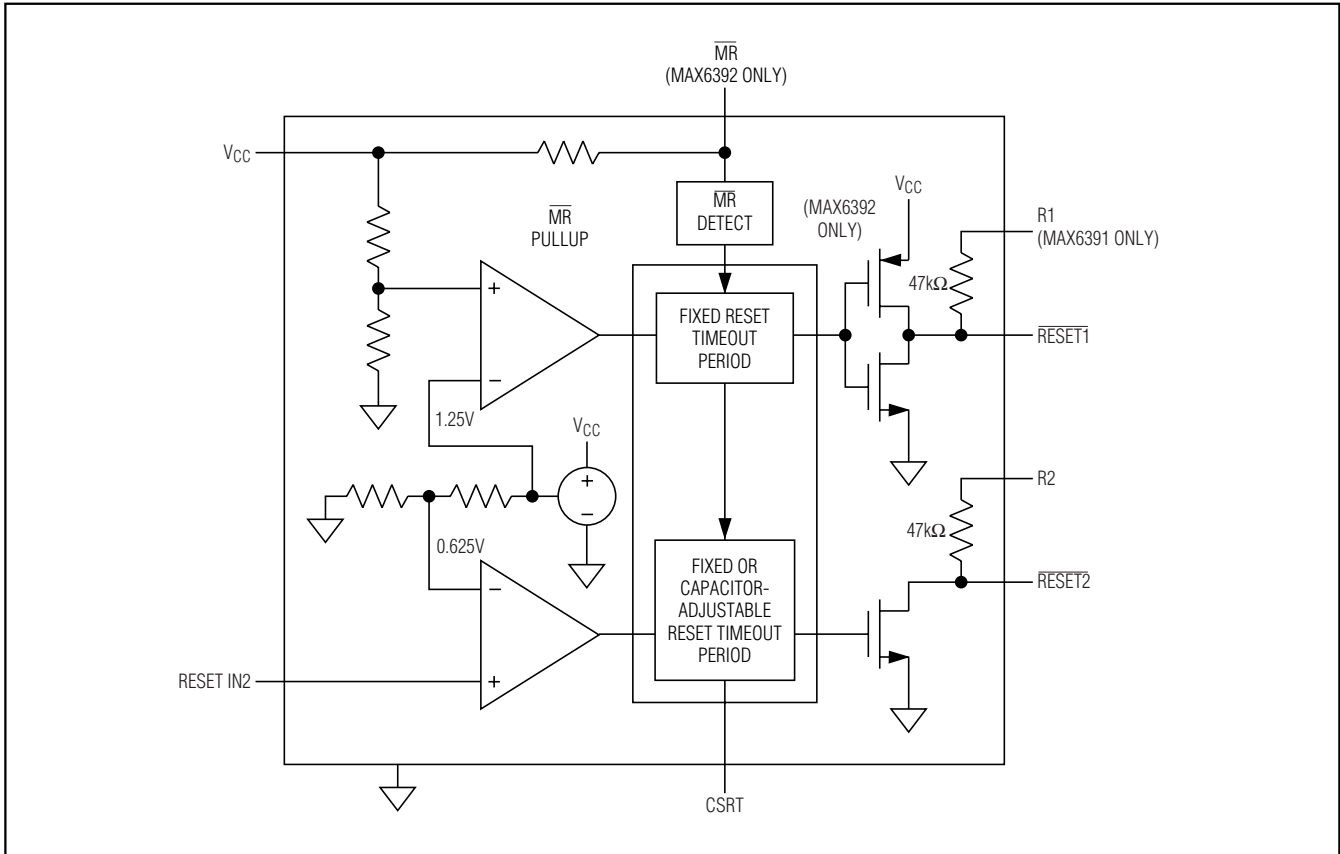

Figure 1. Functional Diagram

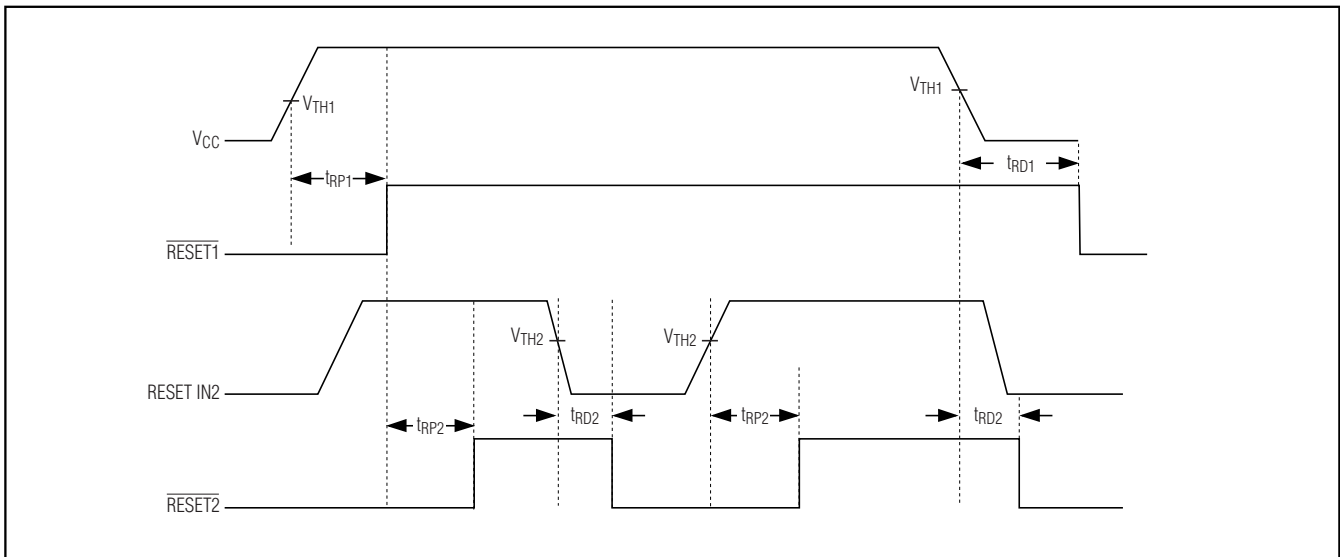

Figure 2. Timing Diagram

Dual-Voltage μ P Supervisory Circuits with Sequenced Reset Outputs

Selector Guide

PART NUMBER	NOMINAL THRESHOLD (V)	TOP MARK
MAX6391KA 46	4.63	AAHJ
MAX6391KA44	4.38	AAHK
MAX6391KA31	3.08	AAHL
MAX6391KA 29	2.93	AAHM
MAX6391KA26	2.63	AAHN
MAX6391KA 23	2.32	AAHO
MAX6391KA22	2.19	AAHP
MAX6391KA17	1.67	AAHQ
MAX6391KA 16	1.58	AAHR
MAX6392KA 46	4.63	AAHS
MAX6392KA44	4.38	AAHT
MAX6392KA31	3.08	AAHU
MAX6392KA 29	2.93	AAHV
MAX6392KA26	2.63	AAHW
MAX6392KA 23	2.32	AAHX
MAX6392KA22	2.19	AAHY
MAX6392KA17	1.67	AAHZ
MAX6392KA 16	1.58	AAIA

Standard versions in bold face. Samples are typically available for standard versions. Contact factory for availability.

Applications Information

Selecting the Reset Timeout Capacitor

The $\overline{\text{RESET2}}$ delay may be adjusted by the user with an external capacitor connected from the CSRT pin to ground. The MAX6391 includes a 600nA current source that is switched to $\overline{\text{CCSRT}}$ to create a voltage ramp. The voltage ramp is compared to the internal 1.25V reference to set the $\overline{\text{RESET2}}$ delay period. The period is calculated by:

$$\Delta t = C \times \Delta V / I$$

where $\Delta V = 1.25\text{V}$, $I = 600\text{nA}$, and C is the external capacitor.

Simplifying,

$$t_{\text{RP}} = 2.08 \times 10^6 \text{ s} / F \times \overline{\text{CCSRT}}$$

For $\overline{\text{CCSRT}} = 1500\text{pF}$, $t_{\text{RP}} = 3.1\text{ms}$

A fixed internal 140ms (min) reset delay time for $\overline{\text{RESET2}}$ may be chosen by connecting the CSRT pin to V_{CC} . The V_{CC} to CSRT connection disables the voltage ramp and enables a separate fixed delay counter

chain. The MAX6391 internally determines the CSRT connection and provides the proper timing setup.

In all cases, $\overline{\text{RESET IN2}}$ acts as the slave supply. V_{CC} can assert the $\overline{\text{RESET2}}$ output but $\overline{\text{RESET IN2}}$ will have no effect on the $\overline{\text{RESET1}}$ output.

Monitoring Voltages Other Than V_{CC}

An external resistive-divider network is required at $\overline{\text{RESET IN2}}$ for most applications. The divider resistors, $R3$ and $R4$, may be calculated by the following formula:

$$V_{\text{RST}} = V_{\text{TH2}} \times (R3 + R4) / R4$$

where $V_{\text{TH2}} = 625\text{mV}$ (internal reference voltage) and V_{RST} is the desired reset threshold voltage. $R4$ may be set to a conveniently high value (500k Ω for example, to minimize current consumption) and the equation may be solved for $R3$ by:

$$R3 = R4 \times (V_{\text{RST}} / V_{\text{TH2}} - 1)$$

For single-supply operations requiring two reset outputs ($\overline{\text{RESET1}}$ before $\overline{\text{RESET2}}$), connect $\overline{\text{RESET IN2}}$ directly to V_{CC} and adjust $\overline{\text{RESET2}}$ timeout delay with $\overline{\text{CCRST}}$ as desired.

Pullup Resistors

The MAX6391 includes open-drain outputs for both $\overline{\text{RESET1}}$ and $\overline{\text{RESET2}}$. Two internal resistors, $R1$ and $R2$, of 47k Ω each are provided with internal connections to $\overline{\text{RESET1}}$ and $\overline{\text{RESET2}}$. These resistors may be connected to the appropriate external voltage for independent V_{OH} drive with no additional component requirements.

The MAX6392 includes a manual reset option, $\overline{\text{MR}}$, that replaces the $R1$ pullup resistor. The active-low manual reset input forces both $\overline{\text{RESET1}}$ and $\overline{\text{RESET2}}$ low. $\overline{\text{RESET2}}$ is driven active before $\overline{\text{RESET1}}$ in all cases (10 μs typ). The resets follow standard reset timing specifications after the manual reset is released. The manual reset is internally pulled up to V_{CC} through a 47k Ω resistor.

Negative-Going V_{CC} Transients

In addition to issuing a reset to the μP during power-up, power-down, and brownout conditions, these devices are relatively immune to short-duration, negative-going V_{CC} or $\overline{\text{RESET IN2}}$ transients (glitches). The *Typical Operating Characteristics* show the Maximum Transient Duration vs. Reset Comparator Overdrive graph. The graph shows the maximum pulse width that a negative-going V_{CC} transient may typically have without issuing a reset signal. As the amplitude of the transient increases, the maximum allowable pulse width decreases.

Dual-Voltage μ P Supervisory Circuits with Sequenced Reset Outputs

Typical Operating Circuit

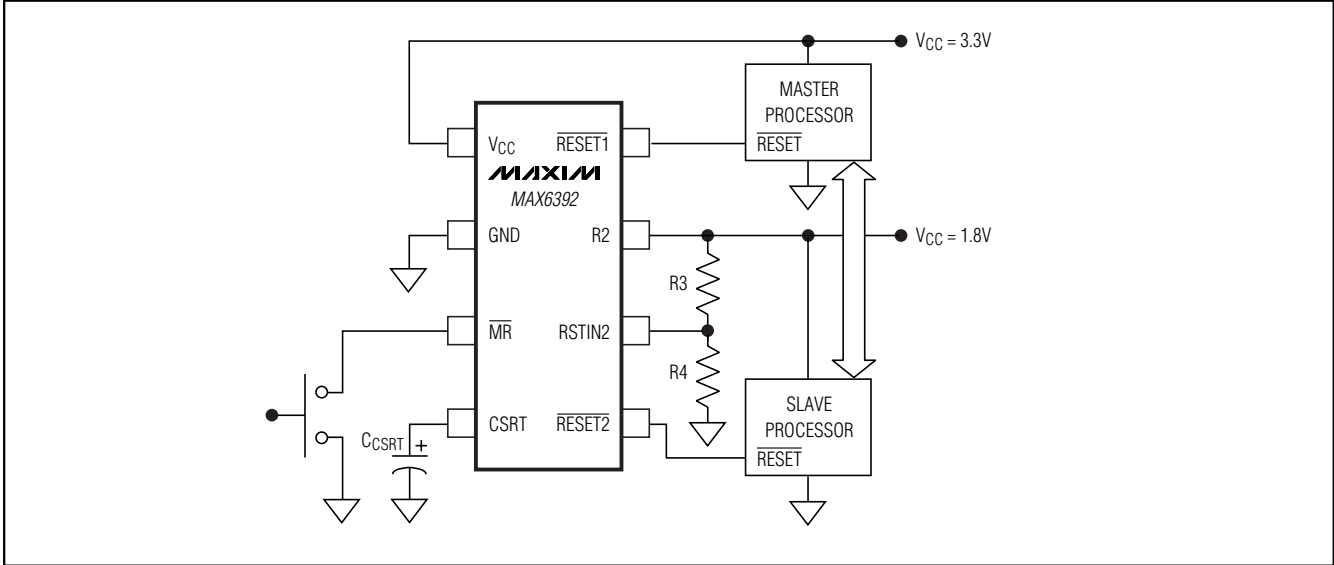

Pin Configurations (continued)

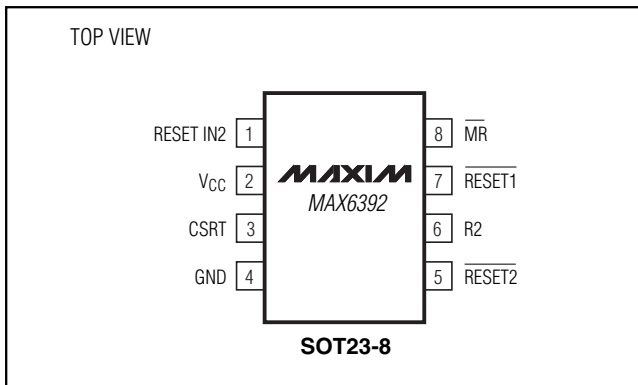

Chip Information

TRANSISTOR COUNT: 810
 PROCESS: BiCMOS

Dual-Voltage μ P Supervisory Circuits with Sequenced Reset Outputs

Package Information

(The package drawing(s) in this data sheet may not reflect the most current specifications. For the latest package outline information go to www.maxim-ic.com/packages.)

MAX6391/MAX6392

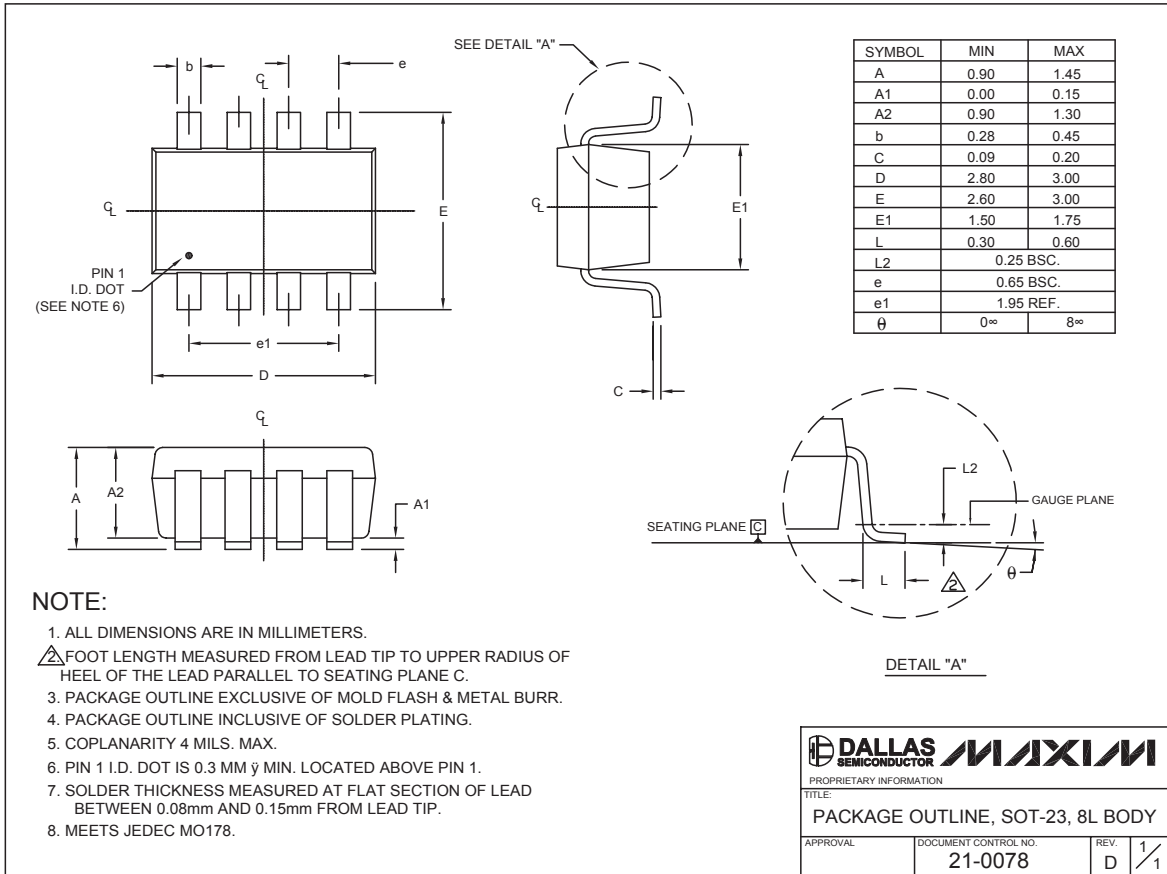

SOT23, 8L EPSS

DALLAS SEMICONDUCTOR **MAXIM**

PROPRIETARY INFORMATION

TITLE:
PACKAGE OUTLINE, SOT-23, 8L BODY

APPROVAL	DOCUMENT CONTROL NO. 21-0078	REV. D	1/1
----------	---------------------------------	-----------	-----

Maxim cannot assume responsibility for use of any circuitry other than circuitry entirely embodied in a Maxim product. No circuit patent licenses are implied. Maxim reserves the right to change the circuitry and specifications without notice at any time.

Maxim Integrated Products, 120 San Gabriel Drive, Sunnyvale, CA 94086 408-737-7600 _____ **9**

Looking for pricing, stock, or lifecycle information?

Click below to explore more details on WIN SOURCE:

 [View MAX6391KA29+T on WIN SOURCE](#)

 [Maxim Integrated](#) Information

Optimize Your Supply Chain with WIN SOURCE Solutions

-  Global Sourcing Solution
-  Obsolete Management
-  Cost Control Management
-  Shortage Management
-  Alternative Solution
-  Excess Inventory Management