



**THE DATASHEET OF  
MAX5387LAUD+**



## MAX5387

## Dual, 256-Tap, Volatile, Low-Voltage Linear Taper Digital Potentiometer

### General Description

The MAX5387 dual, 256-tap, volatile, low-voltage linear taper digital potentiometer offers three end-to-end resistance values of 10k $\Omega$ , 50k $\Omega$ , and 100k $\Omega$ . Operating from a single +2.6V to +5.5V power supply, the device provides a low 35ppm/ $^{\circ}$ C end-to-end temperature coefficient. The device features an I<sup>2</sup>C interface.

The small package size, low supply operating voltage, low supply current, and automotive temperature range of the MAX5387 make the device uniquely suitable for the portable consumer market and battery-backup industrial applications.

The MAX5387 is specified over the automotive -40 $^{\circ}$ C to +125 $^{\circ}$ C temperature range and is available in a 14-pin TSSOP package.

### Applications

- Low-Voltage Battery Applications
- Portable Electronics
- Mechanical Potentiometer Replacement
- Offset and Gain Control
- Adjustable Voltage References/Linear Regulators

### Features

- Dual, 256-Tap Linear Taper Positions
- Single +2.6V to +5.5V Supply Operation
- Low < 1 $\mu$ A Quiescent Supply Current
- 10k $\Omega$ , 50k $\Omega$ , 100k $\Omega$  End-to-End Resistance Values
- I<sup>2</sup>C-Compatible Interface
- Power-On Sets Wiper to Midscale
- -40 $^{\circ}$ C to + 125 $^{\circ}$ C Operating Temperature Range

### Ordering Information

PART	PIN-PACKAGE	END-TO-END RESISTANCE (k $\Omega$ )
MAX5387LAUD+	14 TSSOP	10
MAX5387MAUD+	14 TSSOP	50
MAX5387NAUD+	14 TSSOP	100

**Note:** All devices are specified over the -40 $^{\circ}$ C to +125 $^{\circ}$ C operating temperature range.

+Denotes a lead(Pb)-free/RoHS-compliant package.

### Functional Diagram

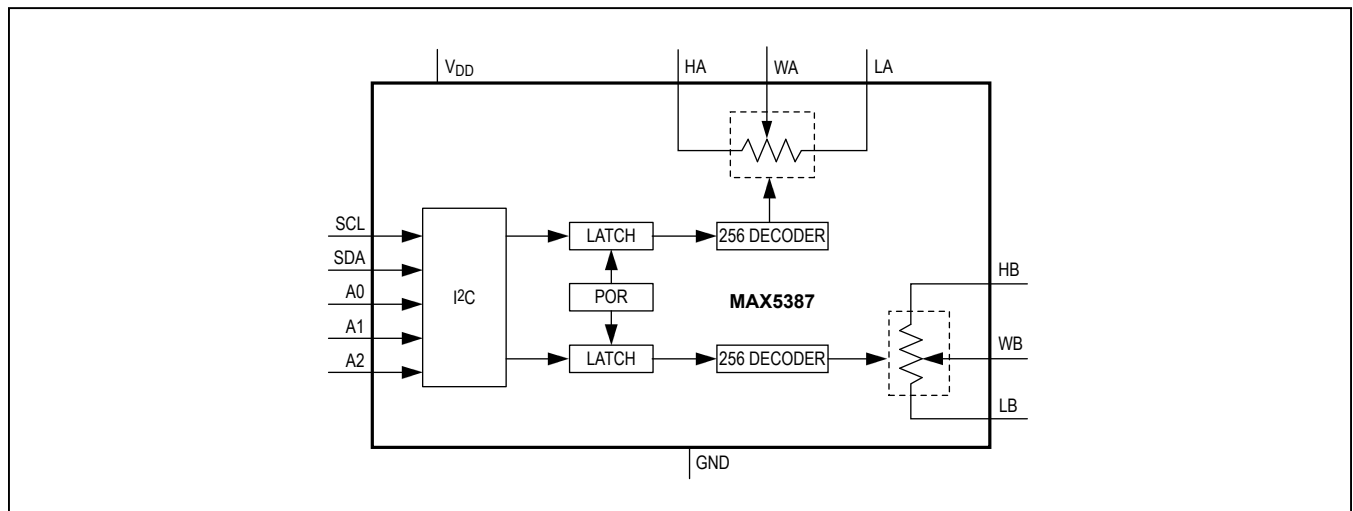

**Absolute Maximum Ratings**

V<sub>DD</sub> to GND .....-0.3V to +6V  
 H<sub>-</sub>, W<sub>-</sub>, L<sub>-</sub> to GND ..... -0.3V to the lower of  
 (V<sub>DD</sub> + 0.3V) and +6V  
 All Other Pins to GND.....-0.3V to +6V  
 Continuous Current into H<sub>-</sub>, W<sub>-</sub>, and L<sub>-</sub>  
 MAX5387L.....±5mA  
 MAX5387M.....±2mA  
 MAX5387N.....±1mA

Continuous Power Dissipation (T<sub>A</sub> = +70°C)  
 14-Pin TSSOP (derate 10mW/°C above +70°C).....796.8mW  
 Operating Temperature Range.....-40°C to +125°C  
 Junction Temperature..... +150°C  
 Storage Temperature Range.....-65°C to +150°C  
 Lead Temperature (soldering, 10s) ..... +300°C  
 Soldering Temperature (reflow)..... +260°C

Stresses beyond those listed under "Absolute Maximum Ratings" may cause permanent damage to the device. These are stress ratings only, and functional operation of the device at these or any other conditions beyond those indicated in the operational sections of the specifications is not implied. Exposure to absolute maximum rating conditions for extended periods may affect device reliability.

**Electrical Characteristics**

(V<sub>DD</sub> = +2.6V to +5.5V, V<sub>H-</sub> = V<sub>DD</sub>, V<sub>L-</sub> = GND, T<sub>A</sub> = -40°C to +125°C, unless otherwise noted. Typical values are at V<sub>DD</sub> = +5V, T<sub>A</sub> = +25°C.) (Note 1)

PARAMETER	SYMBOL	CONDITIONS	MIN	TYP	MAX	UNITS	
Resolution	N		256			Tap	
<b>DC PERFORMANCE (Voltage-Divider Mode)</b>							
Integral Nonlinearity	INL	(Note 2)	-0.5		+0.5	LSB	
Differential Nonlinearity	DNL	(Note 2)	-0.5		+0.5	LSB	
Dual Code Matching		Register A = register B	-0.5		+0.5	LSB	
Ratiometric Resistor Tempco		(ΔV <sub>W</sub> /ΔV <sub>W</sub> )/ΔT; no load		+5		LSB	
Full-Scale Error		Code = FFH	MAX5387L	-3	-2.5	LSB	
			MAX5387M	-1	-0.5		
			MAX5387N	-0.5	-0.25		
Zero-Scale Error		Code = 00H	MAX5387L		+2.5	LSB	
			MAX5387M		+0.5		
			MAX5387N		+0.25		
<b>DC PERFORMANCE (Variable-Resistor Mode)</b>							
Integral Nonlinearity	R-INL	V <sub>DD</sub> > +2.6V	MAX5387L		±1.0	LSB	
			MAX5387M		±0.5		
			MAX5387N		±0.25		
		V <sub>DD</sub> > +4.75V	MAX5387L		±0.4		±1.5
			MAX5387M		±0.3		±0.75
			MAX5387N		±0.25		±0.5
Differential Nonlinearity	R-DNL	V <sub>DD</sub> > 2.6V (Note 3)	-0.5		+0.5	LSB	
<b>DC PERFORMANCE (Resistor Characteristics)</b>							
Wiper Resistance (Note 4)	R <sub>WL</sub>	V <sub>DD</sub> > 2.6V		250	600	Ω	
		V <sub>DD</sub> > 4.75V		150	200		
Terminal Capacitance	C <sub>H</sub> , C <sub>L</sub>	Measured to GND		10		pF	
Wiper Capacitance	C <sub>W</sub>	Measured to GND		50		pF	
End-to-End Resistor Tempco	TC <sub>R</sub>	No load		35		ppm/°C	
End-to-End Resistor Tolerance	ΔR <sub>HL</sub>	Wiper not connected	-25		+25	%	

## Electrical Characteristics (continued)

( $V_{DD} = +2.6V$  to  $+5.5V$ ,  $V_{H\_} = V_{DD}$ ,  $V_{L\_} = GND$ ,  $T_A = -40^{\circ}C$  to  $+125^{\circ}C$ , unless otherwise noted. Typical values are at  $V_{DD} = +5V$ ,  $T_A = +25^{\circ}C$ .) (Note 1)

PARAMETER	SYMBOL	CONDITIONS	MIN	TYP	MAX	UNITS
<b>AC PERFORMANCE</b>						
Crosstalk		(Note 5)		-90		dB
-3dB Bandwidth	BW	Code = 80H, 10pF load, $V_{DD} = +2.6V$	MAX5387L	600		kHz
			MAX5387M	150		
			MAX5387N	75		
Total Harmonic Distortion Plus Noise	THD+N	Measured at W; $V_{H\_} = 1V_{RMS}$ at 1kHz		0.015		%
Wiper Settling Time (Note 6)	$t_S$	MAX5387L		300		ns
		MAX5387M		1000		
		MAX5387N		2000		
<b>POWER SUPPLIES</b>						
Supply-Voltage Range	$V_{DD}$		2.6		5.5	V
Standby Current		Digital inputs = $V_{DD}$ or GND		1		$\mu A$
<b>DIGITAL INPUTS</b>						
Minimum Input High Voltage	$V_{IH}$		70			% x $V_{DD}$
Maximum Input Low Voltage	$V_{IL}$				30	% x $V_{DD}$
Input Leakage Current			-1		+1	$\mu A$
Input Capacitance				5		pF
<b>TIMING CHARACTERISTICS (Notes 7, 8)</b>						
Maximum SCL Frequency	$f_{SCL}$				400	kHz
Setup Time for START Condition	$t_{SU:STA}$		0.6			$\mu s$
Hold Time for START Condition	$t_{HD:STA}$		0.6			$\mu s$
SCL High Time	$t_{HIGH}$		0.6			$\mu s$
SCL Low Time	$t_{LOW}$		1.3			$\mu s$
Data Setup Time	$t_{SU:DAT}$		100			ns
Data Hold Time	$t_{HD:DAT}$		0			$\mu s$
SDA, SCL Rise Time	$t_R$				0.3	$\mu s$
SDA, SCL Fall	$t_F$				0.3	$\mu s$
Setup Time for STOP Condition	$t_{SU:STO}$		0.6			$\mu s$
Bus Free Time Between STOP and START Conditions	$t_{BUF}$	Minimum power-up rate = $0.2V/\mu s$	1.3			$\mu s$
Pulse-Suppressed Spike Width	$t_{SP}$				50	ns
Capacitive Load for Each Bus	$C_B$				400	pF

**Note 1:** All devices are 100% production tested at  $T_A = +25^{\circ}C$ . Specifications overtemperature limits are guaranteed by design and characterization.

**Note 2:** DNL and INL are measured with the potentiometer configured as a voltage-divider (Figure 1) with  $H\_ = V_{DD}$  and  $L\_ = 0V$ . The wiper terminal is unloaded and measured with an ideal voltmeter.

**Note 3:** R-DNL and R-INL are measured with the potentiometer configured as a variable resistor (Figure 1). DNL and INL are measured with the potentiometer configured as a variable resistor.  $H\_$  is unconnected and  $L\_ = GND$ . For  $V_{DD} = +5V$ , the wiper terminal is driven with a source current of  $400\mu A$  for the  $10k\Omega$  configuration,  $80\mu A$  for the  $50k\Omega$  configuration, and  $40\mu A$  for the  $100k\Omega$  configuration. For  $V_{DD} = +2.6V$ , the wiper terminal is driven with a source current of  $200\mu A$  for the  $10k\Omega$  configuration,  $40\mu A$  for the  $50k\Omega$  configuration, and  $20\mu A$  for the  $100k\Omega$  configuration.

**Note 4:** The wiper resistance is the worst value measured by injecting the currents given in Note 3 into  $W\_$  with  $L\_ = GND$ .  $R_W = (V_W - V_H)/I_W$ .

**Electrical Characteristics (continued)**

- Note 5:** Drive HA with a 1kHz GND to V<sub>DD</sub> amplitude tone. LA = LB = GND. No load. WB is at midscale with a 10pF load. Measure WB.
- Note 6:** The wiper settling time is the worst-case 0 to 50% rise time, measured between tap 0 and tap 127. H<sub>-</sub> = V<sub>DD</sub>, L<sub>-</sub> = GND, and the wiper terminal is loaded with 10pF capacitance to ground.
- Note 7:** Digital timing is guaranteed by design and characterization, not production tested.
- Note 8:** The SCL clock period includes rise and fall times (t<sub>R</sub> = t<sub>F</sub>) = 2ns and timed from a voltage level of (V<sub>IL</sub> + V<sub>IH</sub>)/2.

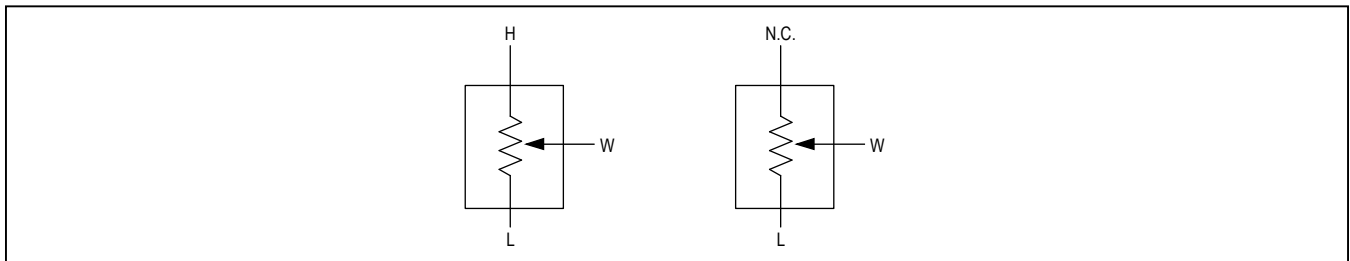
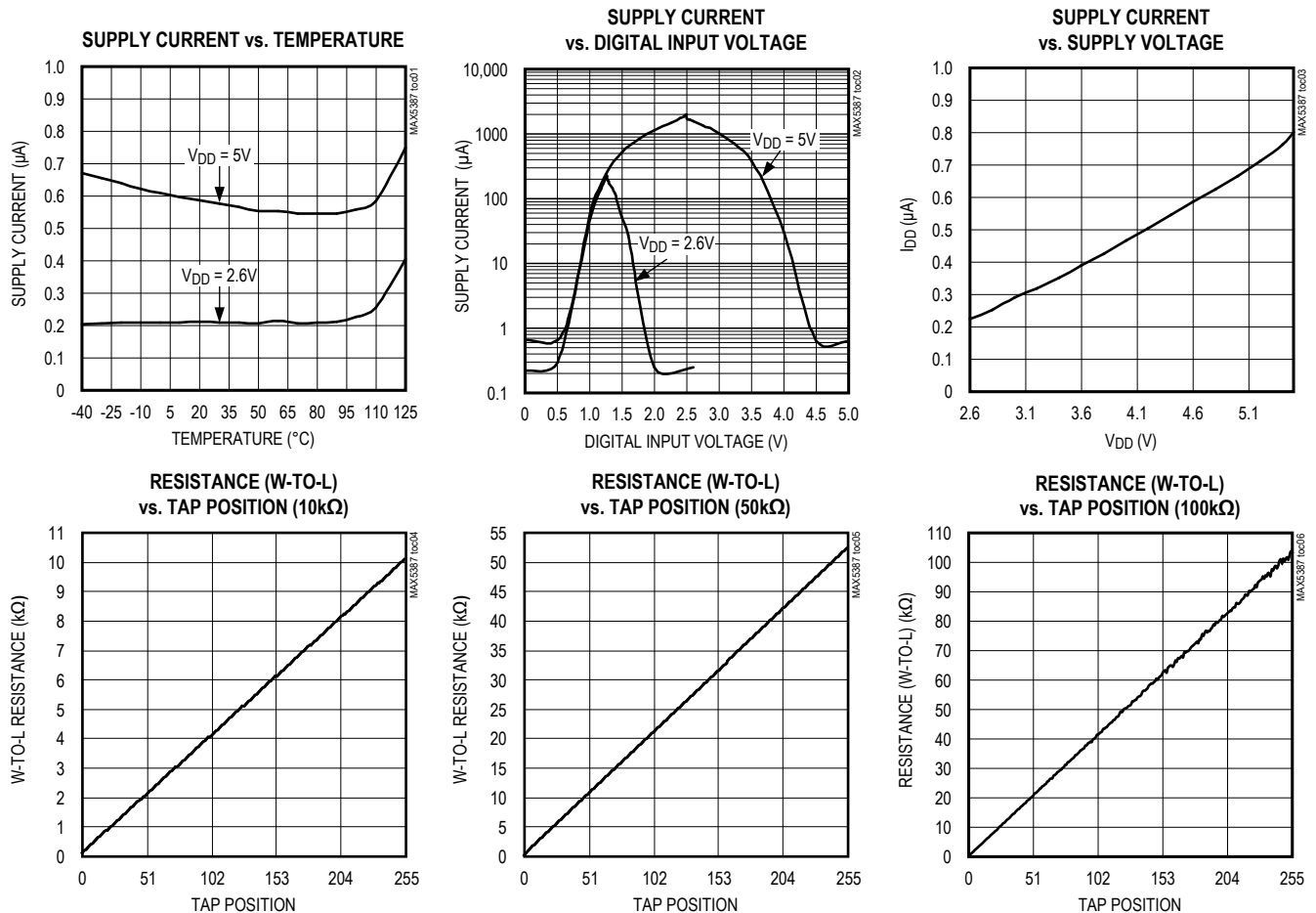

Figure 1. Voltage-Divider and Variable Resistor Configurations

**Typical Operating Characteristics**

(V<sub>DD</sub> = 5V, T<sub>A</sub> = +25°C, unless otherwise noted.)



Typical Operating Characteristics (continued)

( $V_{DD} = 5V$ ,  $T_A = +25^\circ C$ , unless otherwise noted.)

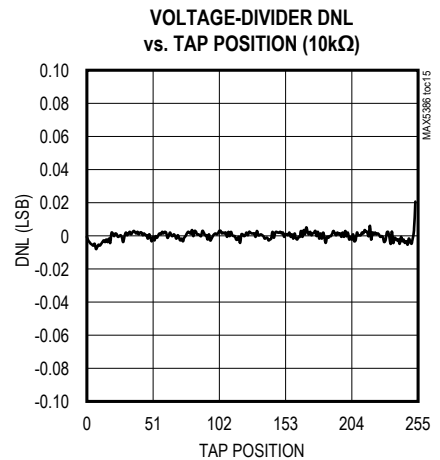
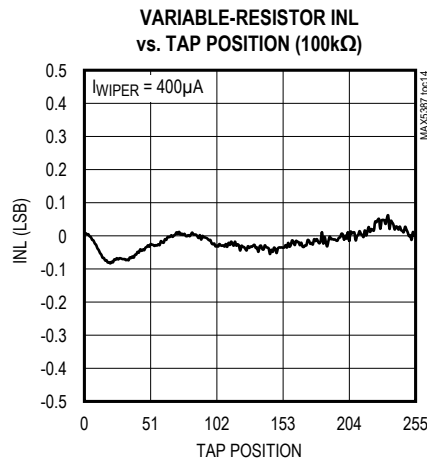
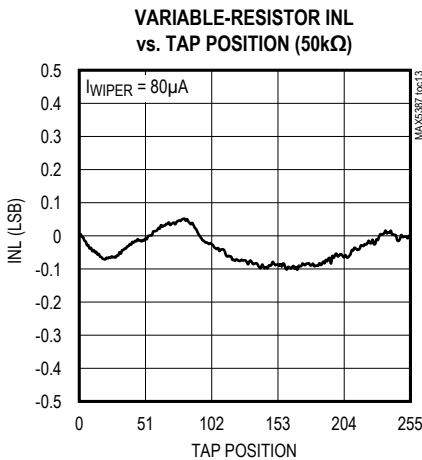
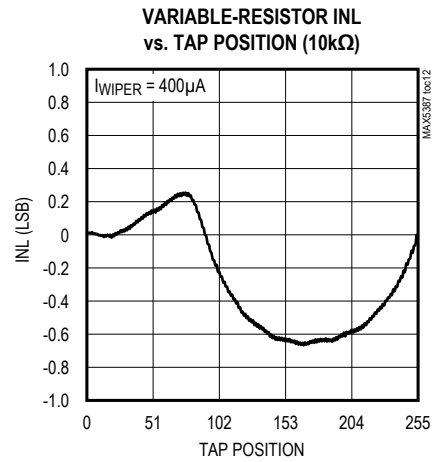
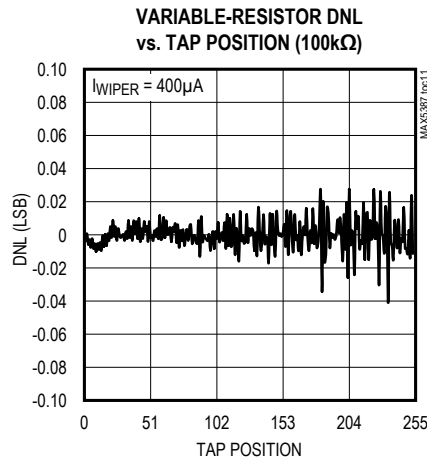
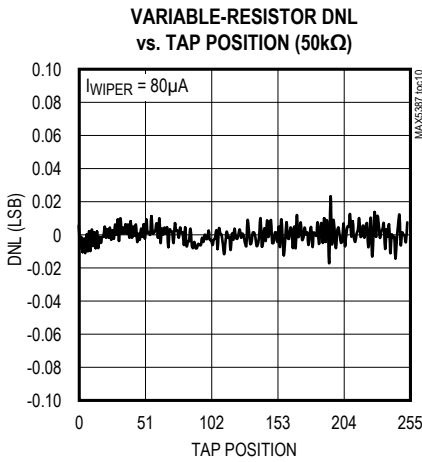
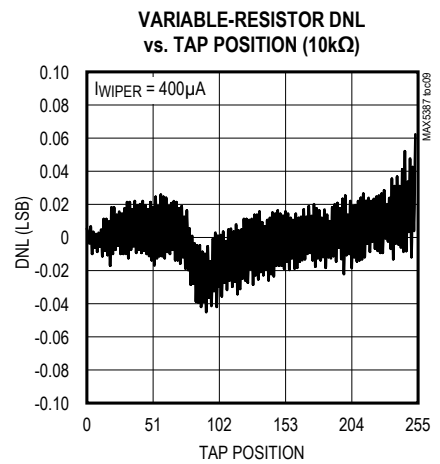
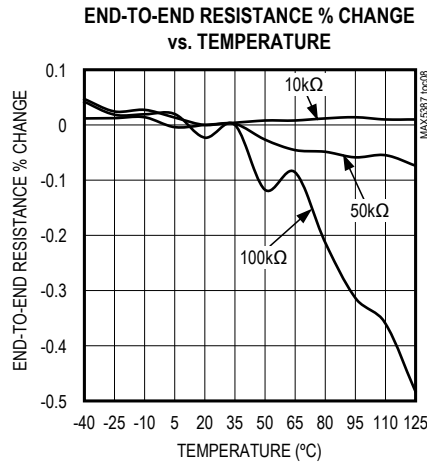
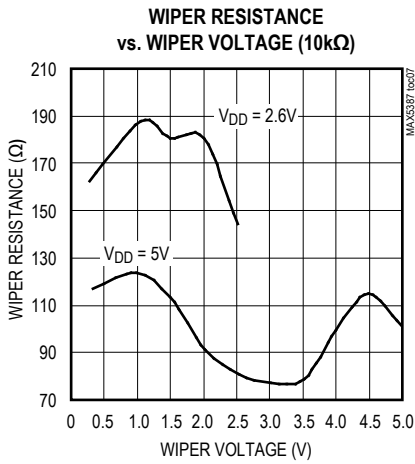

Typical Operating Characteristics (continued)

( $V_{DD} = 5V$ ,  $T_A = +25^\circ C$ , unless otherwise noted.)

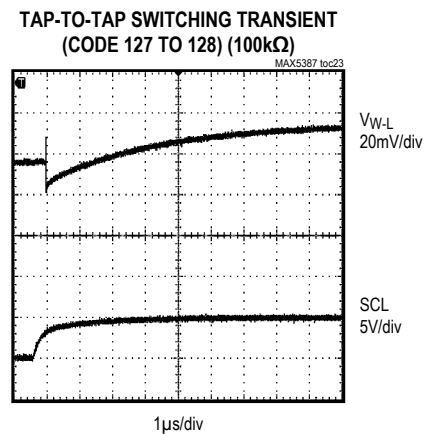
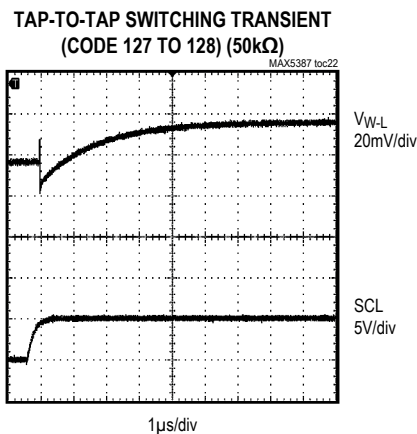
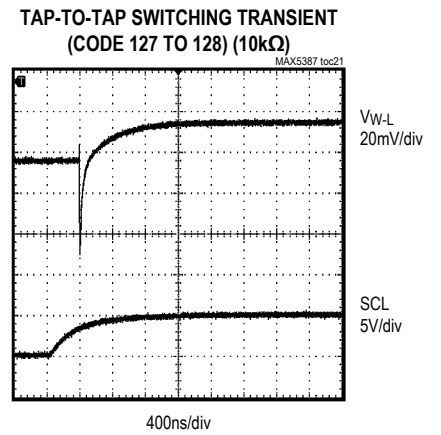
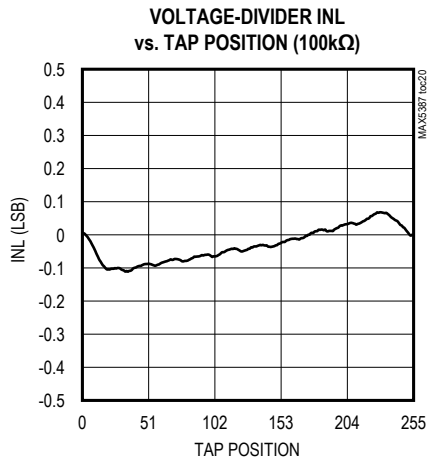
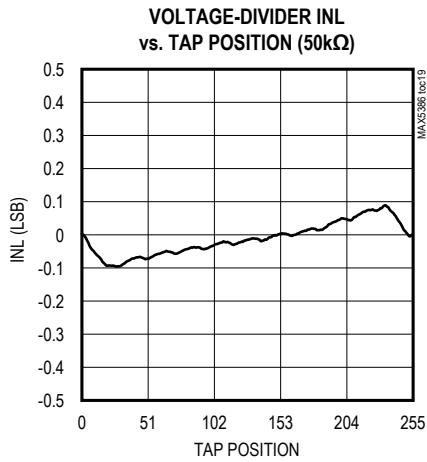
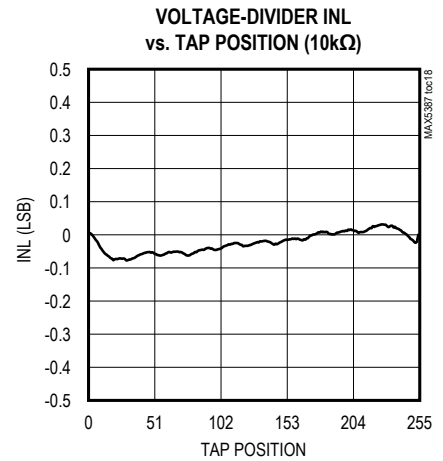
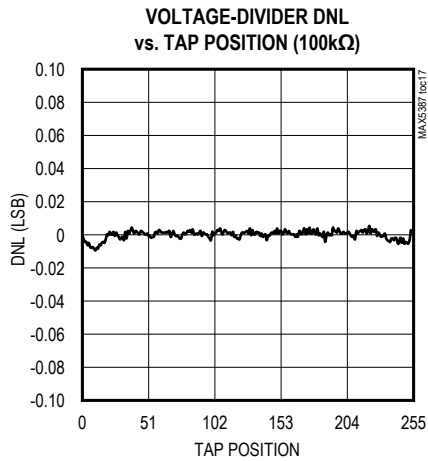
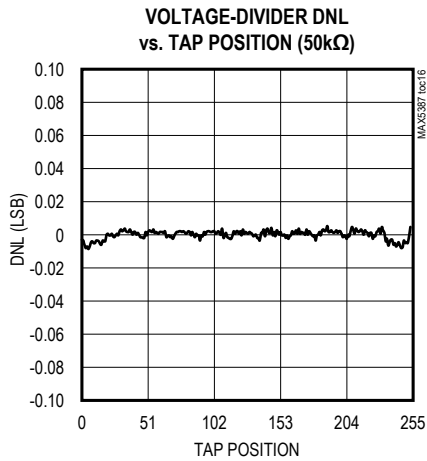

Typical Operating Characteristics (continued)

( $V_{DD} = 5V$ ,  $T_A = +25^\circ C$ , unless otherwise noted.)

MAX5387 POWER-ON WIPER TRANSIENT (CODE 0 TO 128)

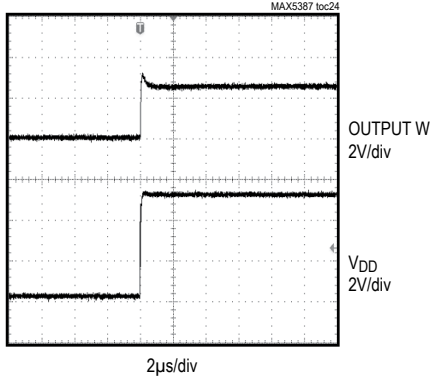

MIDSCALE FREQUENCY RESPONSE

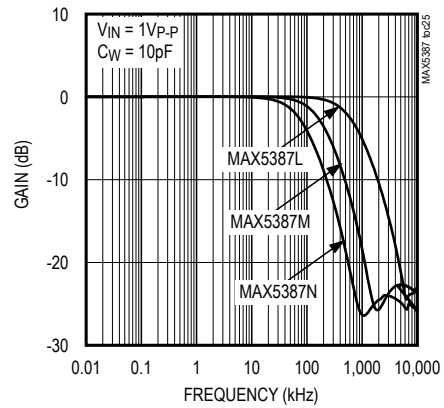

CROSSTALK vs. FREQUENCY

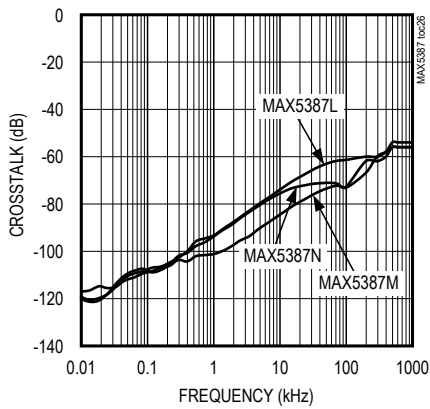

TOTAL HARMONIC DISTORTION PLUS NOISE vs. FREQUENCY

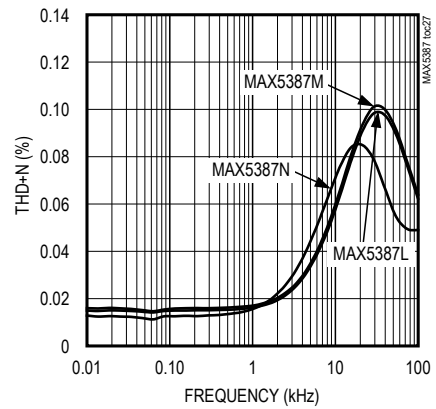

Pin Configuration

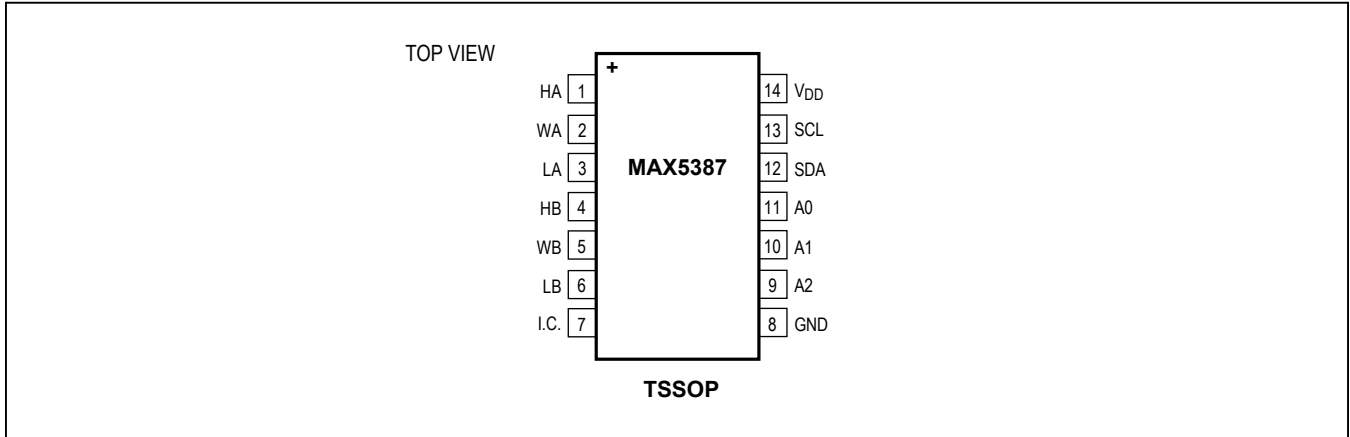

Pin Description

PIN	NAME	FUNCTION
1	HA	Resistor A High Terminal. The voltage at HA can be higher or lower than the voltage at LA. Current can flow into or out of HA.
2	WA	Resistor A Wiper Terminal
3	LA	Resistor A Low Terminal. The voltage at LA can be higher or lower than the voltage at HA. Current can flow into or out of LA.
4	HB	Resistor B High Terminal. The voltage at HB can be higher or lower than the voltage at LB. Current can flow into or out of HB.
5	WB	Resistor B Wiper Terminal
6	LB	Resistor B Low Terminal. The voltage at LB can be higher or lower than the voltage at HB. Current can flow into or out of LB.
7	I.C.	Internally Connected. Connect to GND.
8	GND	Ground
9	A2	Address Input 2. Connect to V <sub>DD</sub> or GND.
10	A1	Address Input 1. Connect to V <sub>DD</sub> or GND.
11	A0	Address Input 0. Connect to V <sub>DD</sub> or GND.
12	SDA	I <sup>2</sup> C-Compatible Serial-Data Input/Output. A pullup resistor is required.
13	SCL	I <sup>2</sup> C-Compatible Serial-Clock Input. A pullup resistor is required.
14	V <sub>DD</sub>	Power-Supply Input. Bypass V <sub>DD</sub> to GND with a 0.1µF capacitor close to the device.

### Detailed Description

The MAX5387 dual, 256-tap, volatile, low-voltage linear taper digital potentiometer offers three end-to-end resistance values of 10kΩ, 50kΩ, and 100kΩ. The potentiometer consists of 255 fixed resistors in series between terminals H<sub>-</sub> and L<sub>-</sub>. The potentiometer wiper, W<sub>-</sub>, is programmable to access any one of the 256 tap points on the resistor string.

The potentiometers are programmable independently of each other. The MAX5387 features an I<sup>2</sup>C interface.

### I<sup>2</sup>C Digital Interface

The I<sup>2</sup>C interface contains a shift register that decodes the command and address bytes, routing the data to the appropriate control registers. Data written to a control register immediately updates the wiper position. Wipers A and B power up in midposition, D[7:0] = 80H.

### Serial Addressing

The MAX5387 operates as a slave device that receives data through an I<sup>2</sup>C-/SMBus™-compatible 2-wire serial interface. The interface uses a serial-data access (SDA) line and a serial-clock line (SCL) to achieve bidirectional communication between master(s) and slave(s). A mas-

ter, typically a microcontroller, initiates all data transfers to the MAX5387, and generates the SCL clock that synchronizes the data transfer (Figure 2).

The MAX5387 SDA line operates as both an input and an open-drain output. The SDA line requires a pullup resistor, typically 4.7kΩ. The MAX5387 SCL line operates only as an input. The SCL line requires a pullup resistor (typically 4.7kΩ) if there are multiple masters on the 2-wire interface, or if the master in a single-master system provides an open-drain SCL output.

Each transmission consists of a START (S) condition (Figure 3) sent by a master, followed by the MAX5387 7-bit slave address plus the NOP/̄W bit (Figure 6), 1 command byte and 1 data byte, and finally a STOP (P) condition (Figure 3).

### START and STOP Conditions

SCL and SDA remain high when the interface is inactive. A master controller signals the beginning of a transmission with a START condition by transitioning SDA from high to low while SCL is high. The master controller issues a STOP condition by transitioning the SDA from low to high while SCL is high, after finishing communicating with the slave. The bus is then free for another transmission.

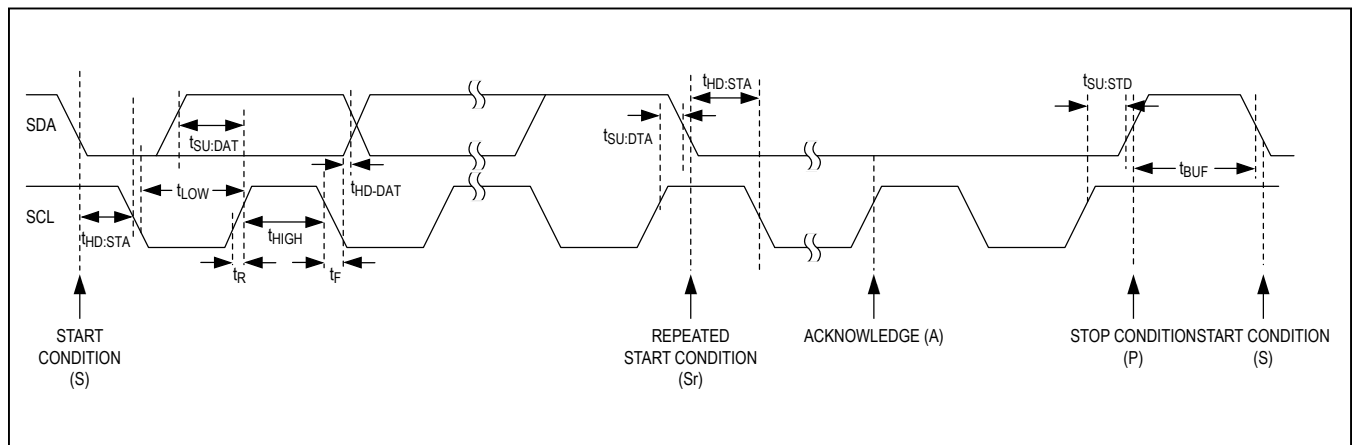

Figure 2. I<sup>2</sup>C Serial Interface Timing Diagram

SMBus is a trademark of Intel Corp.

**Bit Transfer**

One data bit is transferred during each clock pulse. The data on the SDA line must remain stable while SCL is high. See Figure 4.

**Acknowledge**

The acknowledge bit is a clocked 9th bit that the recipient uses to handshake receipt of each byte of data. See Figure 5. Each byte transferred requires a total of nine bits. The master controller generates the 9th clock pulse, and the recipient pulls down SDA during the acknowledge clock pulse, so the SDA line remains stable low during the high period of the clock pulse.

**Slave Address**

The MAX5387 includes a 7-bit slave address (Figure 6). The 8th bit following the 7th bit of the slave address is the NOP/ $\bar{W}$  bit. Set the NOP/ $\bar{W}$  bit low for a write command and high for a no-operation command. The device does not support readback.

The device provides three address inputs (A0, A1, and A2), allowing up to eight devices to share a common bus (Table 1). The first 4 bits (MSBs) of the factory-set slave addresses are always 0101. A2, A1, and A0 set the next 3 bits of the slave address. Connect each address input to  $V_{DD}$  or GND. Each device must have a unique address to share a common bus.

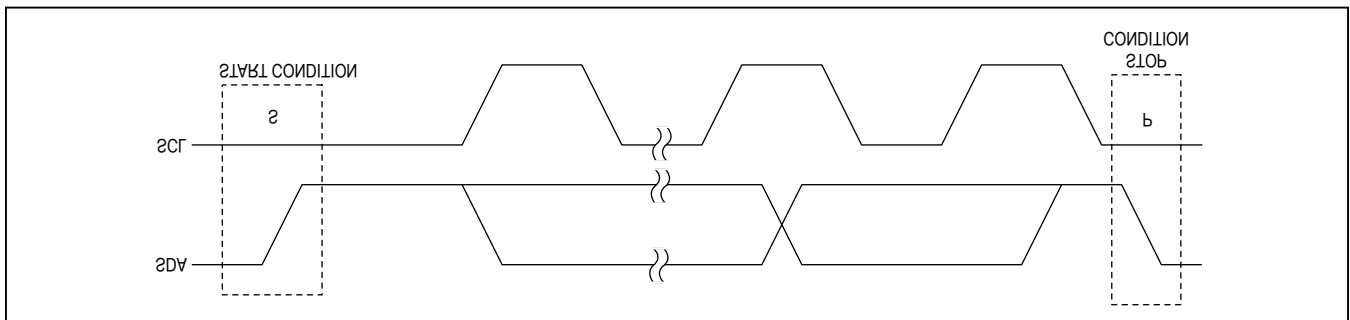

Figure 3. START and STOP Conditions

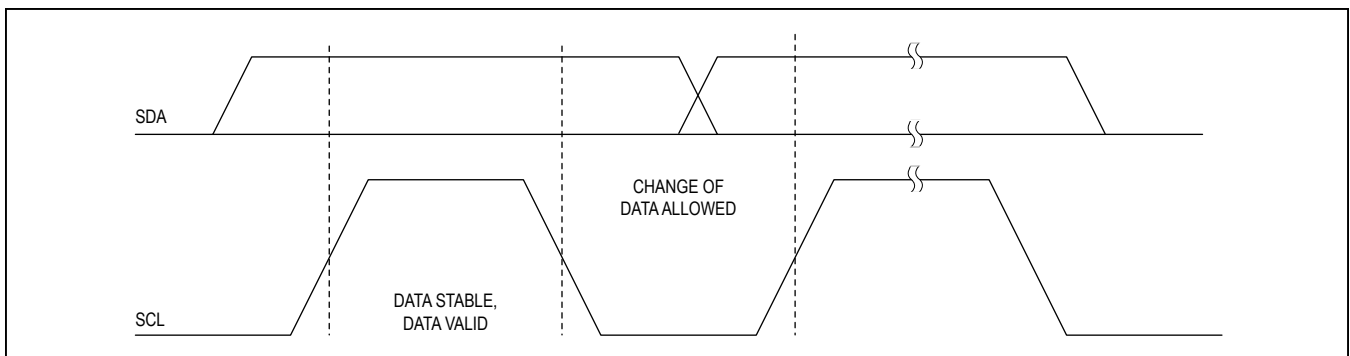

Figure 4. Bit Transfer

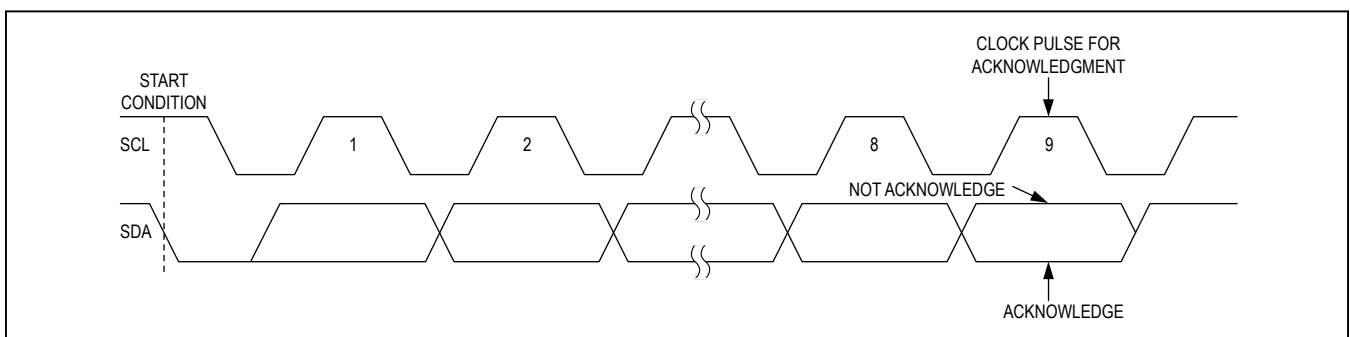

Figure 5. Acknowledge

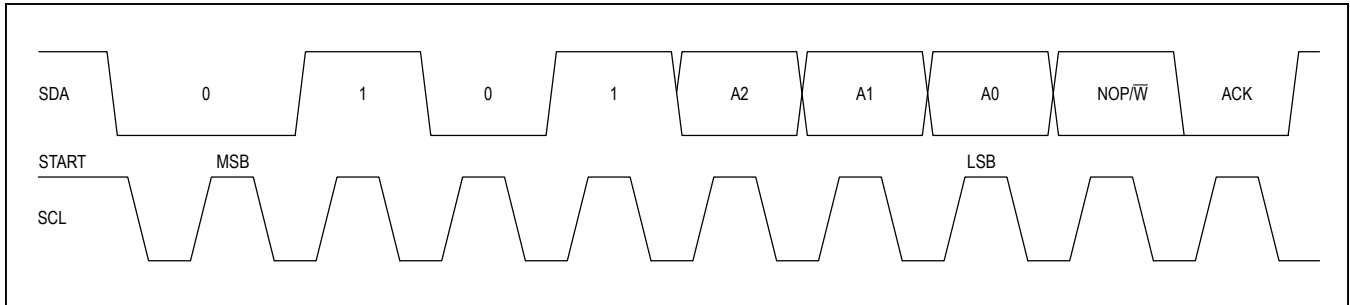

Figure 6. Slave Address

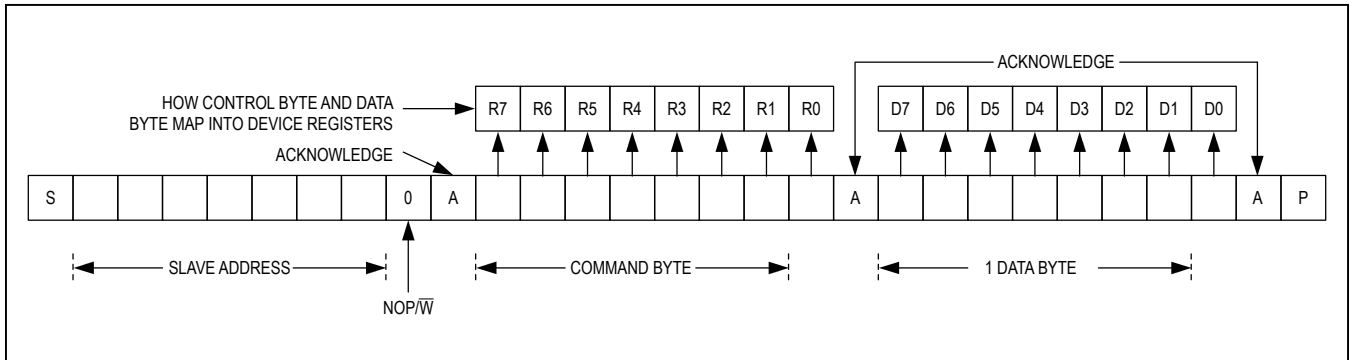

Figure 7. Command and Single Data Byte Received

**Message Format for Writing**

Write to the devices by transmitting the device’s slave address with  $\text{NOP}/\overline{\text{W}}$  (eighth bit) set to zero, followed by at least 2 bytes of information. The first byte of information is the command byte. The second byte is the data byte. The data byte goes into the internal register of the device as selected by the command byte (Figure 7 and Table 2).

**Command Byte**

Use the command byte to select the destination of the wiper data. See Table 2.

**Command Descriptions**

**REG A:** The data byte writes to register A and the wiper of potentiometer A moves to the appropriate position. D[7:0] indicates the position of the wiper. D[7:0] = 00h moves the

wiper to the position closest to LA. D[7:0] = FFh moves the wiper to the position closest to HA. D[7:0] is 80h following power-on.

**Table 1. Slave Addresses**

ADDRESS INPUTS			SLAVE ADDRESS
A2	A1	A0	
GND	GND	GND	0101000
GND	GND	V <sub>DD</sub>	0101001
GND	V <sub>DD</sub>	GND	0101010
GND	V <sub>DD</sub>	V <sub>DD</sub>	0101011
V <sub>DD</sub>	GND	GND	0101100
V <sub>DD</sub>	GND	V <sub>DD</sub>	0101101
V <sub>DD</sub>	V <sub>DD</sub>	GND	0101110
V <sub>DD</sub>	V <sub>DD</sub>	V <sub>DD</sub>	0101111

**Table 2. I2C Command Byte Summary**

SCL CYCLE NO.	START (S)	ADDRESS BYTE								COMMAND BYTE								DATA BYTE								STOP (P)			
		1	2	3	4	5	6	7	8	9	10	11	12	13	14	15	16	17	18	19	20	21	22	23	24		25	26	27
		A6	A5	A4	A3	A2	A1	A0	$\bar{W}$	ACK (A)	R7	R6	R5	R4	R3	R2	R1	R0	ACK (A)	D7	D6	D5	D4	D3	D2	D1	D0	ACK (A)	
REG A		0	1	0	1	A2	A1	A0	0		0	0	0	1	0	0	0	1		D7	D6	D5	D4	D3	D2	D1	D0		
REG B		0	1	0	1	A2	A1	A0	0		0	0	0	1	0	0	1	0		D7	D6	D5	D4	D3	D2	D1	D0		
REGS A AND B		0	1	0	1	A2	A1	A0	0		0	0	0	1	0	0	1	1		D7	D6	D5	D4	D3	D2	D1	D0		

**REG B:** The data byte writes to register B and the wiper of potentiometer B moves to the appropriate position. D[7:0] indicates the position of the wiper. D[7:0] = 00h moves the wiper to the position closest to LB. D[7:0] = FFh moves the wiper to the position closest to HB. D[7:0] is 80h following power-on.

**REGS A and B:** The data byte writes to registers A and B and the wipers of potentiometers A and B move to the appropriate position. D[7:0] indicates the position of the wiper. D[7:0] = 00h moves the wipers to the position closest to L\_. D[7:0] = FFh moves the wipers to the position closest to H\_. D[7:0] is 80h following power-on.

**Applications Information**

**Variable Gain Amplifier**

Figure 8 shows a potentiometer adjusting the gain of a noninverting amplifier. Figure 9 shows a potentiometer adjusting the gain of an inverting amplifier.

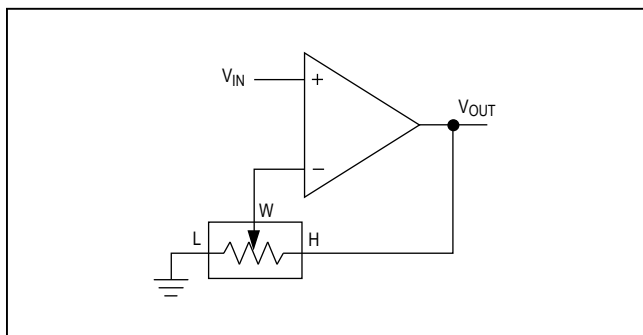

Figure 8. Variable Gain Noninverting Amplifier

**Adjustable Dual Regulator**

Figure 10 shows an adjustable dual linear regulator using a dual potentiometer as two variable resistors.

**Adjustable Voltage Reference**

Figure 11 shows an adjustable voltage reference circuit using a potentiometer as a voltage-divider.

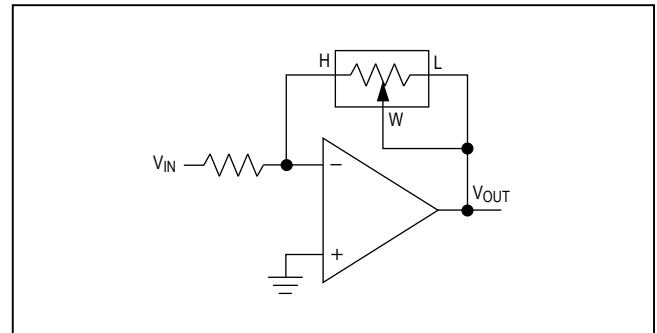

Figure 9. Variable Gain Inverting Amplifier

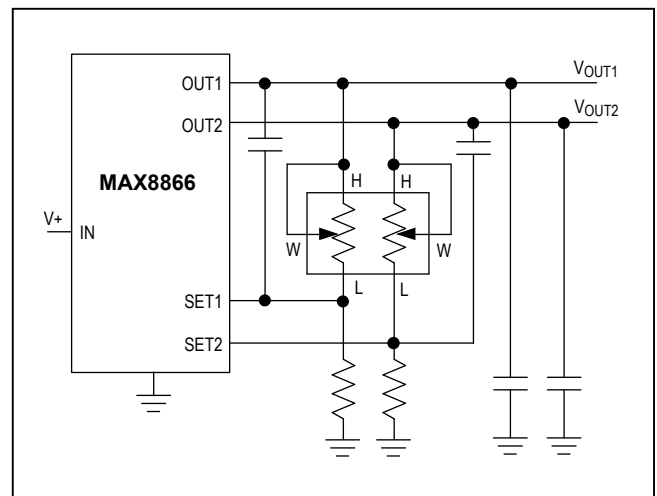

Figure 10. Adjustable Dual Linear Regulator

**Variable Gain Current to Voltage Converter**

Figure 12 shows a variable gain current to voltage converter using a potentiometer as a variable resistor.

**LCD Bias Control**

Figure 13 shows a positive LCD bias control circuit using a potentiometer as a voltage-divider.

Figure 14 shows a positive LCD bias control circuit using a potentiometer as a variable resistor.

**Programmable Filter**

Figure 15 shows a programmable filter using a dual potentiometer.

**Offset-Voltage Adjustment Circuit**

Figure 16 shows an offset-voltage adjustment circuit using a dual potentiometer.

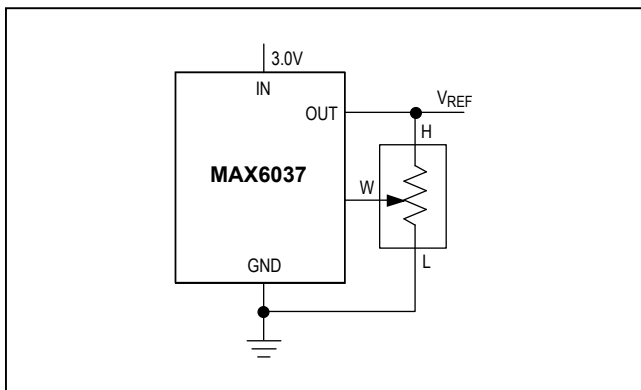

Figure 11. Adjustable Voltage Reference

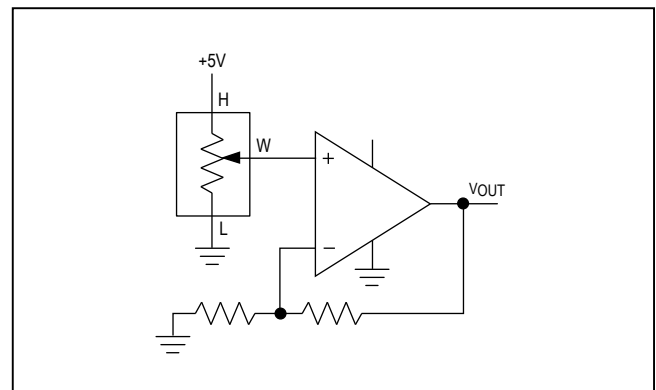

Figure 13. Positive LCD Bias Control Using a Voltage-Divider

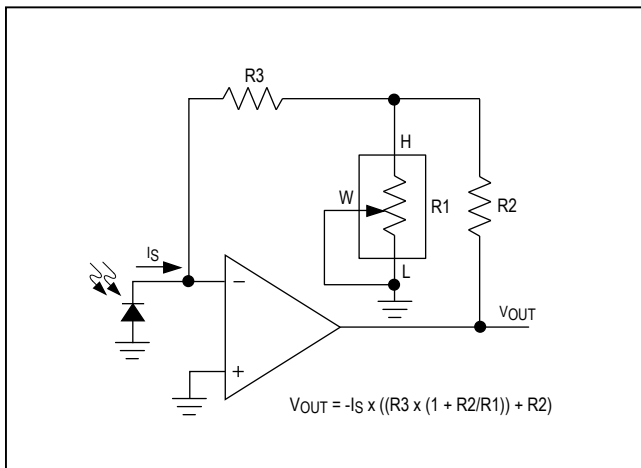

Figure 12. Variable Gain I-to-V Converter

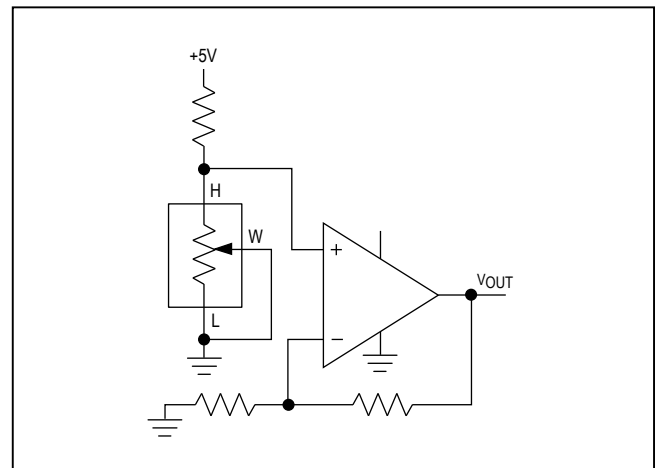

Figure 14. Positive LCD Bias Control Using a Variable Resistor

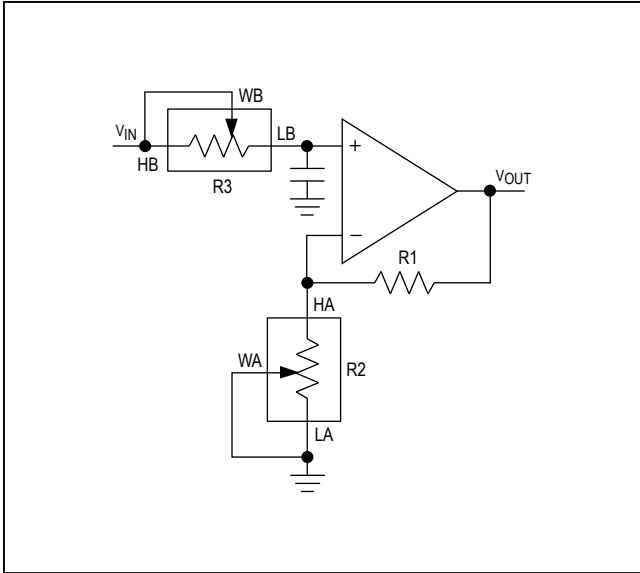

Figure 15. Programmable Filter

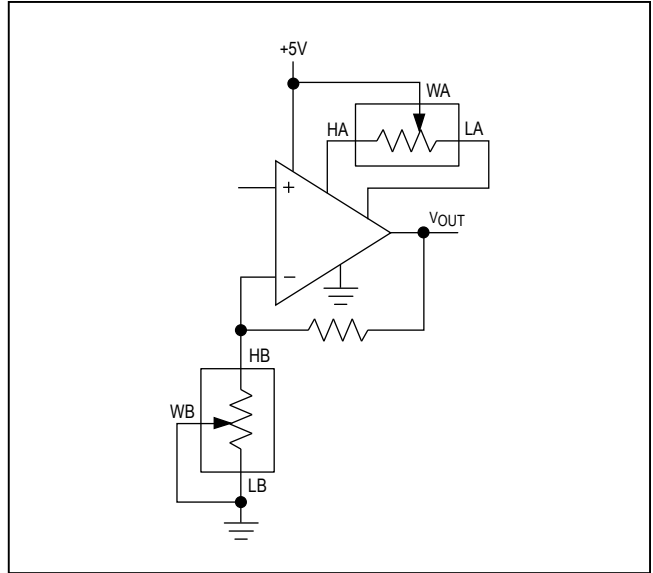

Figure 16. Offset-Voltage Adjustment Circuit

### Chip Information

PROCESS: BICMOS

### Package Information

For the latest package outline information and land patterns (footprints), go to [www.maximintegrated.com/packages](http://www.maximintegrated.com/packages). Note that a "+", "#", or "-" in the package code indicates RoHS status only. Package drawings may show a different suffix character, but the drawing pertains to the package regardless of RoHS status.

PACKAGE TYPE	PACKAGE CODE	OUTLINE NO.	LAND PATTERN NO.
14 TSSOP	U14+1	<a href="#">21-0066</a>	<a href="#">90-0113</a>

## Revision History

REVISION NUMBER	REVISION DATE	DESCRIPTION	PAGES CHANGED
0	1/10	Initial release	—
1	4/10	Added Soldering Temperature in <i>Absolute Maximum Ratings</i> ; corrected code in Conditions of -3dB Bandwidth specification in <i>Electrical Characteristics</i>	2
2	11/10	Updated figures for optimal circuit operation	12, 13, 14
3	9/14	Removed automotive references from data sheet	1

For pricing, delivery, and ordering information, please contact Maxim Direct at 1-888-629-4642, or visit Maxim Integrated's website at [www.maximintegrated.com](http://www.maximintegrated.com).

Maxim Integrated cannot assume responsibility for use of any circuitry other than circuitry entirely embodied in a Maxim Integrated product. No circuit patent licenses are implied. Maxim Integrated reserves the right to change the circuitry and specifications without notice at any time. The parametric values (min and max limits) shown in the Electrical Characteristics table are guaranteed. Other parametric values quoted in this data sheet are provided for guidance.

## Looking for pricing, stock, or lifecycle information?

Click below to explore more details on WIN SOURCE:

 [View MAX5387LAUD+ on WIN SOURCE](#)

 [Maxim Integrated](#) Information

## Optimize Your Supply Chain with WIN SOURCE Solutions

-  Global Sourcing Solution
-  Obsolete Management
-  Cost Control Management
-  Shortage Management
-  Alternative Solution
-  Excess Inventory Management