



THE DATASHEET OF MAX4744HELB





Low-Voltage, Dual SPDT, Audio Clickless Switches with Negative Rail Capability

General Description

The MAX4744/MAX4744H/MAX4745/MAX4745H/MAX4746H dual SPDT (single-pole/double-throw) audio switches feature negative signal capability that allows signals as low as $V_{CC} - 5.5V$ to pass through without distortion. These analog switches have a low on-resistance and low supply current, and operate from a single +1.8V to +5.5V supply.

The MAX4744/MAX4744H have internal shunt resistors that automatically discharge the capacitance at the normally open (NO) and normally closed (NC) terminals when they are not connected. The MAX4746H features internal shunt resistors on NC_ terminals. This reduces click-and-pop sounds that occur when switching audio signals between precharged points. A break-before-make feature further reduces popping. The MAX4744/MAX4745 control the switches with two control bits CB1 and CB2. The MAX4744H/MAX4745H/MAX4746H have one control bit to switch both switches and an enable input \overline{EN} to put the switches in a high-impedance mode. The MAX4744H/MAX4745H/MAX4746H also have an internal protection network against voltages applied to COM_ when $V_{CC} = 0V$.

These devices are available in a space-saving 10-pin μ DFN (2mm x 2mm) package and operate over the -40°C to +85°C extended temperature range.

Applications

Speaker Switching
Power Routing
Cellular Phones
MP3 Players
PDAs and Other Handheld Devices
Notebook Computers

Features

- ◆ Distortion-Free Negative Signal Throughput Down to $V_{CC} - 5.5V$
- ◆ Internal Shunt Resistor Reduces Click/Pop (MAX4744/MAX4744H)
- ◆ 0.6 Ω (typ) Low On-Resistance
- ◆ 0.1 Ω (max) Channel-to-Channel Matching
- ◆ 0.55 Ω (max) On-Resistance Flatness
- ◆ +1.8V to +5.5V Single-Supply Voltage
- ◆ 0.01% (typ) Total Harmonic Distortion
- ◆ -75dB (typ) Crosstalk (100kHz)
- ◆ -68dB (typ) Off-Isolation (100kHz)
- ◆ Available in 10-Pin μ DFN Package (2mm x 2mm)

Pin Configurations

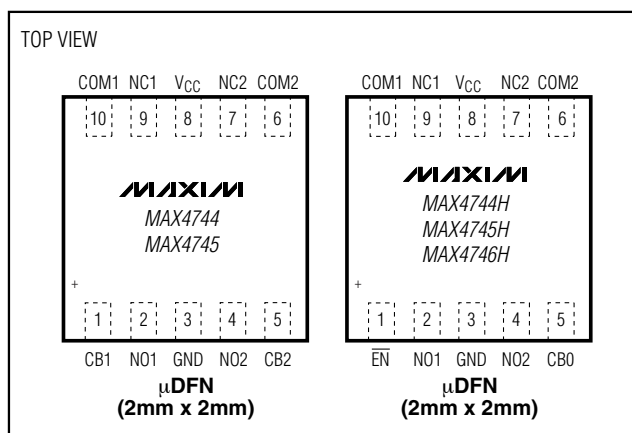

Ordering Information/Selector Guide

| PART | PIN-PACKAGE | TOP MARK | CLICKLESS | COM PROTECTION | PKG CODE |
|---------------|-----------------|----------|-------------|----------------|----------|
| MAX4744ELB+T | 10 μ DFN-10 | +AAF | Yes | No | L1022-1 |
| MAX4744HELB+T | 10 μ DFN-10 | +AAG | Yes | Yes | L1022-1 |
| MAX4745ELB+T | 10 μ DFN-10 | +AAH | No | No | L1022-1 |
| MAX4745HELB+T | 10 μ DFN-10 | +AAI | No | Yes | L1022-1 |
| MAX4746HELB+T | 10 μ DFN-10 | +AAM | Yes, on NC_ | Yes | L1022-1 |

Note: All devices are specified over the -40°C to +85°C operating temperature range.

+Denotes a lead-free package.



For pricing, delivery, and ordering information, please contact Maxim/Dallas Direct! at 1-888-629-4642, or visit Maxim's website at www.maxim-ic.com.

Low-Voltage, Dual SPDT, Audio Clickless Switches with Negative Rail Capability

ABSOLUTE MAXIMUM RATINGS

(All voltages referenced to GND.)

| | |
|---|---|
| V _{CC} , CB ₋ , EN |-0.3V to +6.0V |
| NC ₋ , NO ₋ |(V _{CC} - 6V) to (V _{CC} + 0.3V) |
| COM ₋ (MAX4744/MAX4745) |(V _{CC} - 6V) to (V _{CC} + 0.3V) |
| COM ₋ (MAX4744H/MAX4745H/MAX4746H) |(Note 1) |
| Continuous Current NO ₋ , NC ₋ , COM ₋ |±300mA |
| Peak Current NO ₋ , NC ₋ , COM ₋ (pulsed at 1ms, 50% duty cycle) |±400mA |

| | |
|--|----------------------|
| Peak Current NO ₋ , NC ₋ , COM ₋ (pulsed at 1ms, 10% duty cycle) |±500mA |
| ESD Protection per Method 3015.7 | |
| NO ₋ , NC ₋ , COM ₋ , V _{CC} , GND, CB ₋ , EN |±2kV |
| Continuous Power Dissipation (T _A = +70°C) | |
| 10-Pin µDFN (derate 5mW/°C above +70°C) |403mW |
| Operating Temperature Range |-40°C to +85°C |
| Storage Temperature Range |-65°C to +150°C |

Note 1: If V_{CC} > 0.5V, limits are (V_{CC} - 6V) to (V_{CC} + 0.3V). If V_{CC} < 0.5V, limits are (V_{CC} - 6.0V) to +6.0V.

Stresses beyond those listed under "Absolute Maximum Ratings" may cause permanent damage to the device. These are stress ratings only, and functional operation of the device at these or any other conditions beyond those indicated in the operational sections of the specifications is not implied. Exposure to absolute maximum rating conditions for extended periods may affect device reliability.

ELECTRICAL CHARACTERISTICS

(V_{CC} = +2.7V to +5.5V, T_A = -40°C to +85°C, unless otherwise noted. Typical values are at V_{CC} = 3.3V, T_A = +25°C.) (Note 2)

| PARAMETER | SYMBOL | CONDITIONS | MIN | TYP | MAX | UNITS |
|--|---|--|---|------|-----------------|-------|
| POWER SUPPLY | | | | | | |
| Supply-Voltage Range | V _{CC} | | 1.8 | | 5.5 | V |
| Supply Current | I _{CC} | V _{CC} = 5.5V, V _{CB-} = 0V or V _{CC} | | 0.3 | 1 | µA |
| | | V _{CC} = 5.5V, V _{CB-} = 0.5V or 1.4V | | | 8 | |
| | | V _{CC} = 2.7V, V _{CB-} = 0.5V or 1.4V | | | 4 | |
| ANALOG SWITCH | | | | | | |
| Analog Signal Range | V _{NC-} , V _{NO-} , V _{COM-} | (Note 3) | V _{CC} - 5.5V | | V _{CC} | V |
| On-Resistance (Note 4) | R _{ON} | V _{CC} = +2.7V; V _{NC-} or V _{NO-} = V _{CC} - 5.5V, -1V, 0V, 1V, 2V, V _{CC} ; I _{COM-} = 100mA | T _A = +25°C | 0.6 | 0.95 | Ω |
| | | | T _A = T _{MIN} to T _{MAX} | | 1.0 | |
| On-Resistance Match Between Channels (Notes 4 and 5) | ΔR _{ON} | V _{CC} = 2.7V, V _{NC-} or V _{NO-} = 0V, I _{COM-} = 100mA | T _A = +25°C | | 0.1 | Ω |
| | | | T _A = T _{MIN} to T _{MAX} | | 0.1 | |
| On-Resistance Flatness (Note 6) | R _{FLAT} | V _{CC} = +2.7V, V _{NC-} or V _{NO-} = V _{CC} - 5.5V, -1V, 0V, 1V, 2V, V _{CC} ; I _{COM-} = 100mA | T _A = +25°C | | 0.55 | Ω |
| | | | T _A = T _{MIN} to T _{MAX} | | 0.6 | |
| Shunt Switch Resistance | R _{SH} | MAX4744/MAX4744H/MAX4746H only, V _{CC} = 2.7V | 2 | | 5 | kΩ |
| NC ₋ , NO ₋ Off-Leakage Current (Note 3) | I _{NO-(OFF)} , I _{NC-(OFF)} | V _{CC} = +2.7V switch open; V _{NC-} or V _{NO-} = -2.5V, +2.5V (MAX4745/MAX4745H only) (MAX4746H - I _{NO-(OFF)} only) | T _A = +25°C | -15 | +15 | nA |
| | | | T _A = T _{MIN} to T _{MAX} | -50 | +50 | |
| COM ₋ On-Leakage Current (Note 3) | I _{COM-(ON)} | V _{CC} = 2.7V switch closed; V _{NC-} or V _{NO-} = -2.5V, +2.5V; V _{COM-} = -2.5V, +2.5V | T _A = +25°C | -15 | +15 | nA |
| | | | T _A = T _{MIN} to T _{MAX} | -100 | +100 | |

Low-Voltage, Dual SPDT, Audio Clickless Switches with Negative Rail Capability

ELECTRICAL CHARACTERISTICS (continued)

($V_{CC} = +2.7V$ to $+5.5V$, $T_A = -40^{\circ}C$ to $+85^{\circ}C$, unless otherwise noted. Typical values are at $V_{CC} = 3.3V$, $T_A = +25^{\circ}C$.) (Note 2)

| PARAMETER | SYMBOL | CONDITIONS | | MIN | TYP | MAX | UNITS |
|--|-------------------------------|---|--|-----|------|-----|-------|
| COM_ Leakage Under Protection Conditions | $I_{L(Prot)}$ | $V_{CC} = 0V$; $V_{COM_} = +5.5V$; $V_{NC_}$ and $V_{NO_}$ are unconnected or connected to GND; $V_{CB_} = 0V$ (MAX4744H/MAX4745H/MAX4746H only) | $T_A = +25^{\circ}C$ | | 30 | | nA |
| | | | $T_A = T_{MIN}$ to T_{MAX} | | 500 | | |
| DYNAMIC CHARACTERISTICS | | | | | | | |
| Turn-On Time | t_{ON} | $V_{CC} = 2.7V$, $R_L = 32\Omega$, $C_L = 35pF$, Figure 2 | For NO_, $V_{NO_} = 1.5V$, $V_{CB_} = 0V$ to V_{CC} | | 55 | | ns |
| | | | For NC_, $V_{NC_} = 1.5V$, $V_{CB_} = V_{CC}$ to $0V$ | | 560 | | |
| Turn-Off Time | t_{OFF} | $V_{CC} = 2.7V$, $R_L = 32\Omega$, $C_L = 35pF$, Figure 2 | For NO_, $V_{NO_} = 1.5V$, $V_{CB_} = V_{CC}$ to $0V$ | | 540 | | ns |
| | | | For NC_, $V_{NC_} = 1.5V$, $V_{CB_} = 0V$ to V_{CC} | | 36 | | |
| Break-Before-Make Delay Time | t_D | $V_{CC} = 2.7V$, $V_{NC_} = V_{NO_} = 1.5V$; for NO_, $V_{CB_} = V_{CC}$ to $0V$; for NC_, $V_{CB_} = 0V$ to V_{CC} ; $R_L = 32\Omega$; $C_L = 35pF$; Figure 3 | | | 20 | | ns |
| Power-Supply Rejection Ratio | PSRR | $f = 100kHz$, $V_{COM_} = 1V_{RMS}$, $R_L = 50\Omega$, $C_L = 5pF$ | | | 52 | | dB |
| Charge Injection | Q | $V_{GEN_} = 0V$; $R_{GEN} = 0\Omega$, $C_L = 1nF$, Figure 4 | | | 450 | | pC |
| Off-Isolation | V_{ISO} | $C_L = 5pF$; $R_L = 50\Omega$; $f = 100kHz$; $V_{COM_} = 1V_{RMS}$; Figure 5 (Note 7) | | | -68 | | dB |
| Crosstalk | V_{CT} | $C_L = 5pF$; $R_L = 50\Omega$; $f = 100kHz$; $V_{COM_} = 1V_{RMS}$; Figure 5 | | | -75 | | dB |
| Total Harmonic Distortion | THD | $f = 20Hz$ to $20kHz$, $V_{COM_} = 0.5V_{P-P}$, $R_L = 50\Omega$ | | | 0.01 | | % |
| NO_, NC_ Off-Capacitance | $C_{NO(OFF)}$, $C_{NC(OFF)}$ | $f = 1MHz$, Figure 6 | | | 90 | | pF |
| COM On-Capacitance | $C_{COM(ON)}$ | $f = 1MHz$, Figure 6 | | | 300 | | pF |

MAX4744/MAX4744H/MAX4745/MAX4745H/MAX4746H

Low-Voltage, Dual SPDT, Audio Clickless Switches with Negative Rail Capability

ELECTRICAL CHARACTERISTICS (continued)

($V_{CC} = +2.7V$ to $+5.5V$, $T_A = -40^\circ C$ to $+85^\circ C$, unless otherwise noted. Typical values are at $V_{CC} = 3.3V$, $T_A = +25^\circ C$.) (Note 2)

| PARAMETER | SYMBOL | CONDITIONS | MIN | TYP | MAX | UNITS |
|--|------------|--|-----|-----|-----|---------|
| DIGITAL INPUTS (CB₋, EN) | | | | | | |
| Input-Logic High | V_{IH} | | 1.4 | | | V |
| Input-Logic Low | V_{IL} | | | | 0.5 | V |
| Input Leakage Current | I_{LEAK} | V_{CB-} or $V_{EN} = 0V$ or V_{CC} | -1 | | +1 | μA |

Note 2: All parameters are production tested at $T_A = +25^\circ C$ and guaranteed by design over the specified temperature range.

Note 3: Signals on COM₋, NO₋, or NC₋ exceeding V_{CC} are clamped by internal diodes. Limit forward-diode current to maximum current ratings.

Note 4: Guaranteed by design; not production tested.

Note 5: $\Delta R_{ON} = R_{ON(MAX)} - R_{ON(MIN)}$.

Note 6: Flatness is defined as the difference between the maximum and minimum value of on-resistance as measured over the specified analog signal ranges.

Note 7: Off-isolation = $20\log_{10}[V_{COM-} / V_{NO-}]$, V_{COM-} = output, V_{NO-} = input to off switch.

Typical Operating Characteristics

($V_{CC} = +3.3V$, $T_A = +25^\circ C$, unless otherwise noted.)

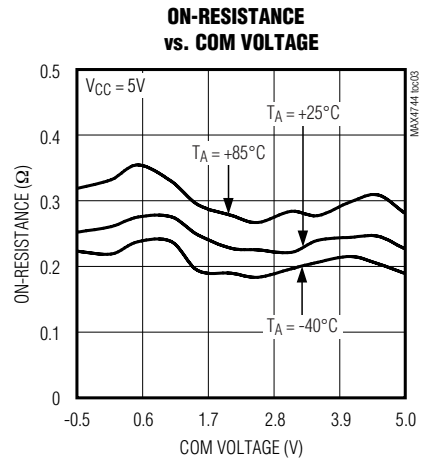
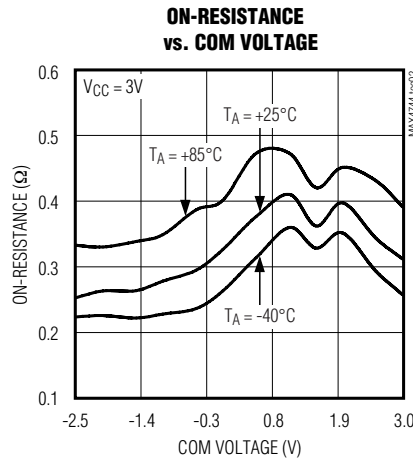
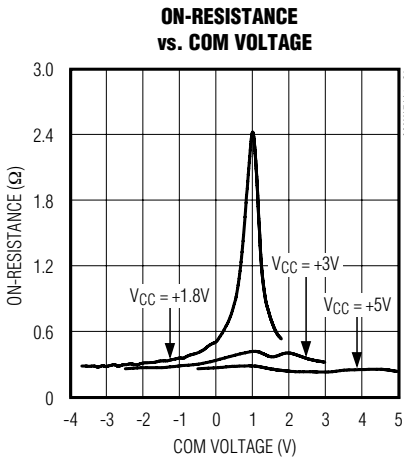

Low-Voltage, Dual SPDT, Audio Clickless Switches with Negative Rail Capability

Typical Operating Characteristics

($V_{CC} = +3.3V$, $T_A = +25^\circ C$, unless otherwise noted.)

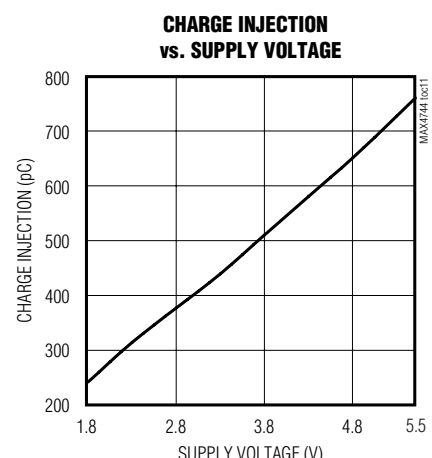
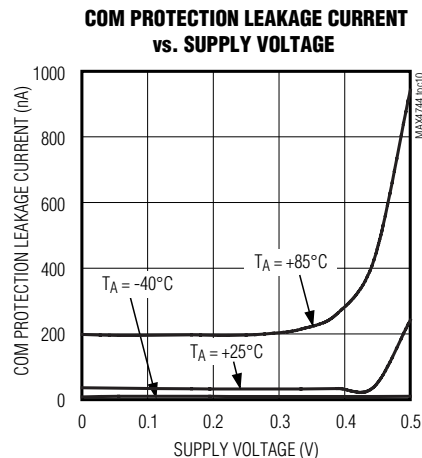
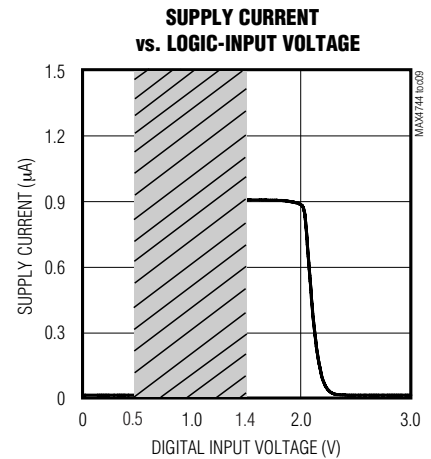
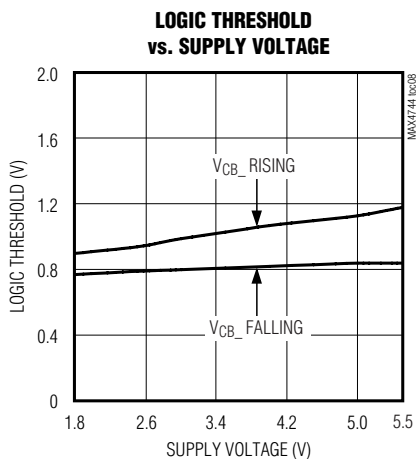
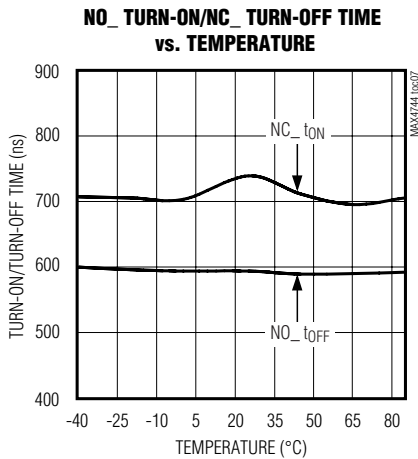
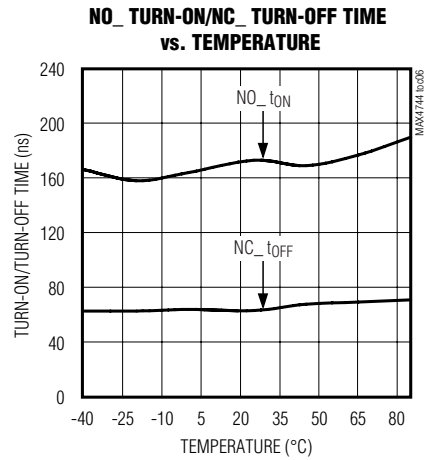
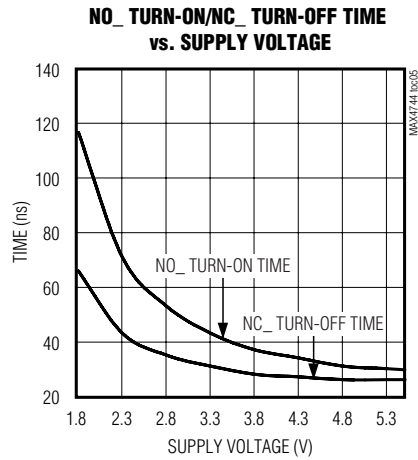
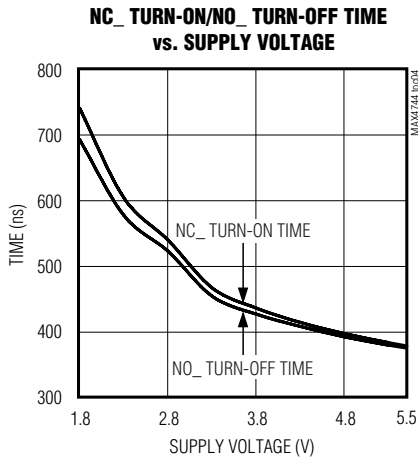

MAX4744/MAX4744H/MAX4745/MAX4745H/MAX4746H

Low-Voltage, Dual SPDT, Audio Clickless Switches with Negative Rail Capability

Typical Operating Characteristics (continued)

($V_{CC} = +3.3V$, $T_A = +25^\circ C$, unless otherwise noted.)

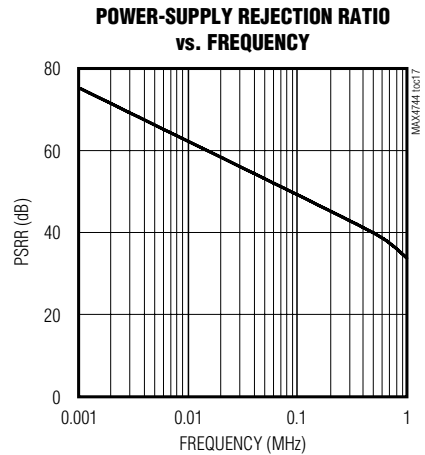
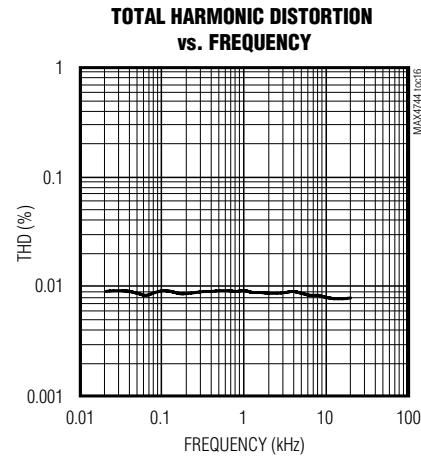
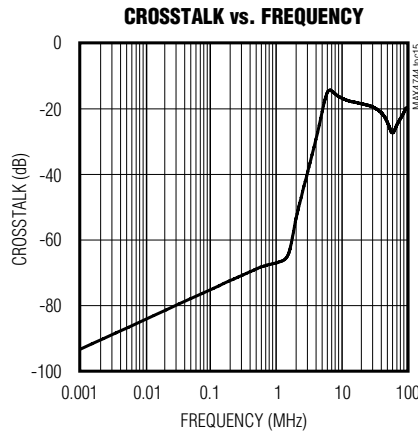
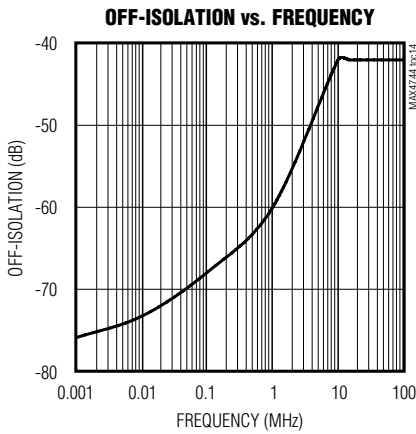
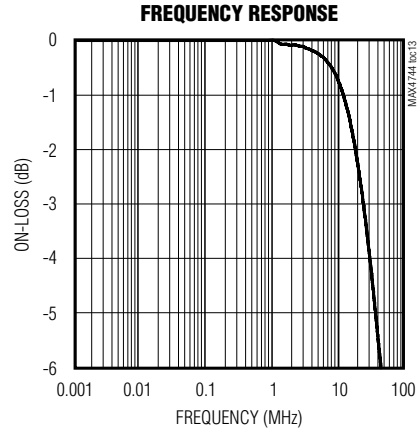
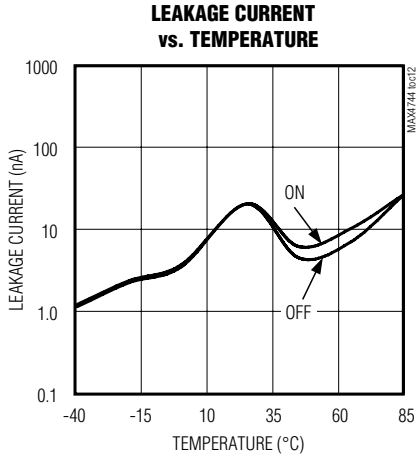

Low-Voltage, Dual SPDT, Audio Clickless Switches with Negative Rail Capability

Pin Description

| PIN | | NAME | FUNCTION |
|---------------------|------------------------------------|-----------------|---|
| MAX4744/ MAX4745 | MAX4744H/ MAX4745H/ MAX4746H | | |
| 1 | — | CB1 | Digital Control Input for Analog Switch 1 |
| — | 1 | \overline{EN} | Enable Input. Driving \overline{EN} high causes all switches to be high impedance. Pull \overline{EN} low for normal operation. |
| 2 | 2 | NO1 | Analog Switch 1—Normally Open Terminal |
| 3 | 3 | GND | Ground |
| 4 | 4 | NO2 | Analog Switch 2—Normally Open Terminal |
| 5 | — | CB2 | Digital Control Input for Analog Switch 2 |
| — | 5 | CB0 | Digital Control Input for Analog Switches 1 and 2 |
| 6 | 6 | COM2 | Analog Switch 2—Common Terminal |
| 7 | 7 | NC2 | Analog Switch 2—Normally Closed Terminal |
| 8 | 8 | V _{CC} | Positive Supply Voltage from +1.8V to +5.5V |
| 9 | 9 | NC1 | Analog Switch 1—Normally Closed Terminal |
| 10 | 10 | COM1 | Analog Switch 1—Common Terminal |

Detailed Description

The MAX4744/MAX4744H/MAX4745/MAX4745H/MAX4746H are low on-resistance, low-voltage, dual-SPDT analog switches that operate from a +1.8V to +5.5V single supply. These devices feature a negative signal capability that allows signals as low as V_{CC} - 5.5V to pass through without distortion.

The MAX4744/MAX4745 feature two digital control bits to control each switch independently (see Table 1). The MAX4744H/MAX4745H/MAX4746H have one control bit to switch both switches and an enable input \overline{EN} to put the switches in a high-impedance mode. Driving \overline{EN} low takes the switches out of high impedance and CB0 controls both switches (see Table 2).

The MAX4744/MAX4744H have internal shunt resistors on all NO and NC terminals, and the MAX4746H has internal shunt resistors on NC terminals to suppress click-and-pop sounds that can occur when switching audio signals between precharged points.

Applications Information

Digital Control Inputs

The MAX4744/MAX4744H/MAX4745/MAX4745H/MAX4746H logic inputs accept up to +5.5V, regardless of supply voltage. For example, with a +3.3V supply, CB0, CB1, CB2, and \overline{EN} can be driven low to GND and

Table 1. MAX4744/MAX4745 Truth Table

| CONTROL | | SWITCH STATE | |
|---------|-----|------------------|------------------|
| CB1 | CB2 | Switch 1 | Switch 2 |
| 0 | 0 | Connected to NC1 | Connected to NC2 |
| 0 | 1 | Connected to NC1 | Connected to NO2 |
| 1 | 0 | Connected to NO1 | Connected to NC2 |
| 1 | 1 | Connected to NO1 | Connected to NO2 |

Table 2. MAX4744H/MAX4745H/MAX4746H Truth Table

| CONTROL | | SWITCH STATE | |
|-----------------|-----|------------------|------------------|
| \overline{EN} | CB0 | Switch 1 | Switch 2 |
| 0 | 0 | Connected to NC1 | Connected to NC2 |
| 0 | 1 | Connected to NO1 | Connected to NO2 |
| 1 | X | High Impedance | High Impedance |

X = Don't Care

high to +5.5V, allowing for mixed logic levels in a system. Driving CB0, CB1, CB2, and \overline{EN} rail-to-rail minimizes power consumption.

MAX4744/MAX4744H/MAX4745/MAX4745H/MAX4746H

Low-Voltage, Dual SPDT, Audio Clickless Switches with Negative Rail Capability

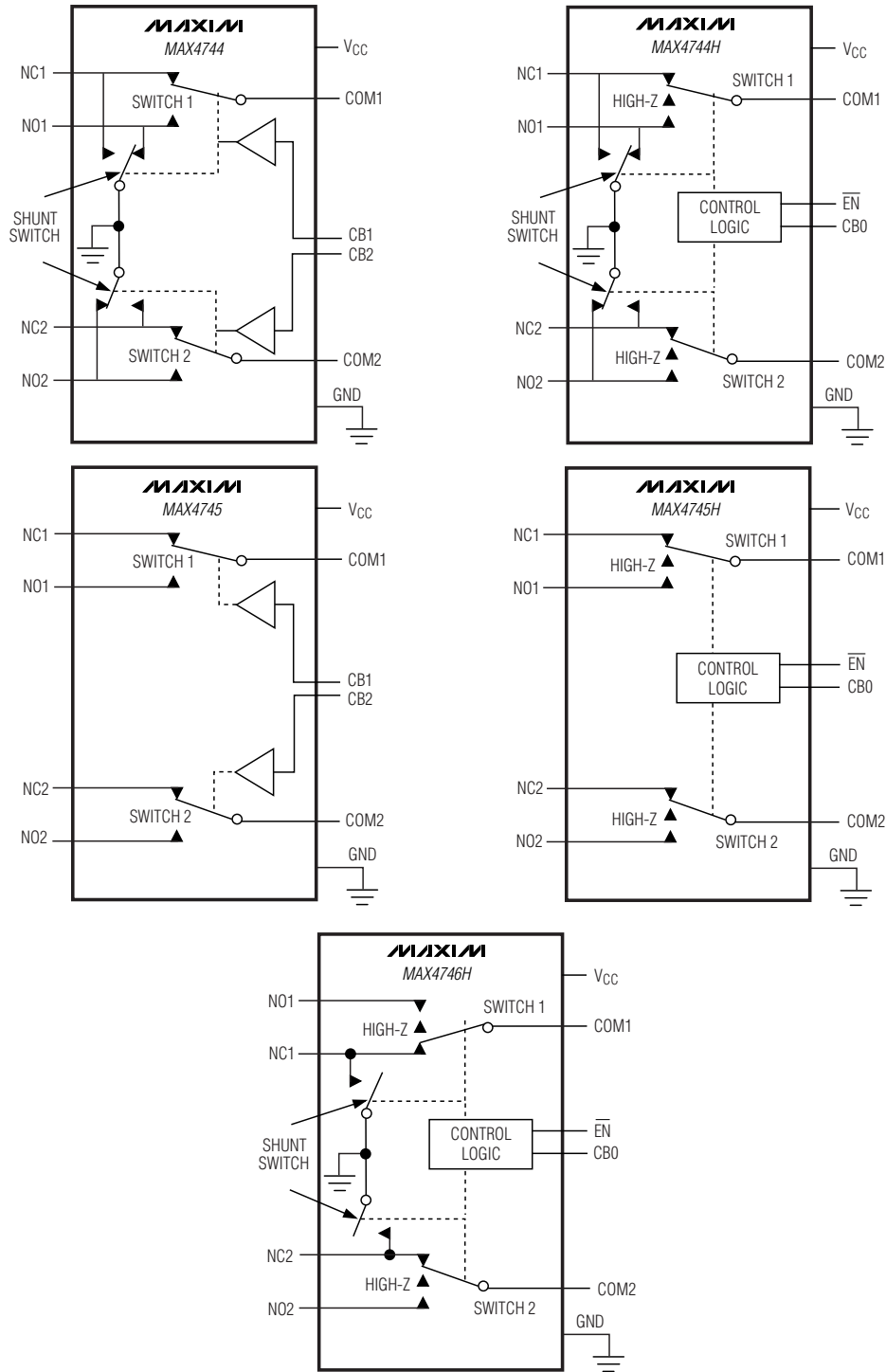

Figure 1. Functional Diagram

Low-Voltage, Dual SPDT, Audio Clickless Switches with Negative Rail Capability

Test Circuits/Timing Diagrams

MAX4744/MAX4744H/MAX4745/MAX4745H/MAX4746H

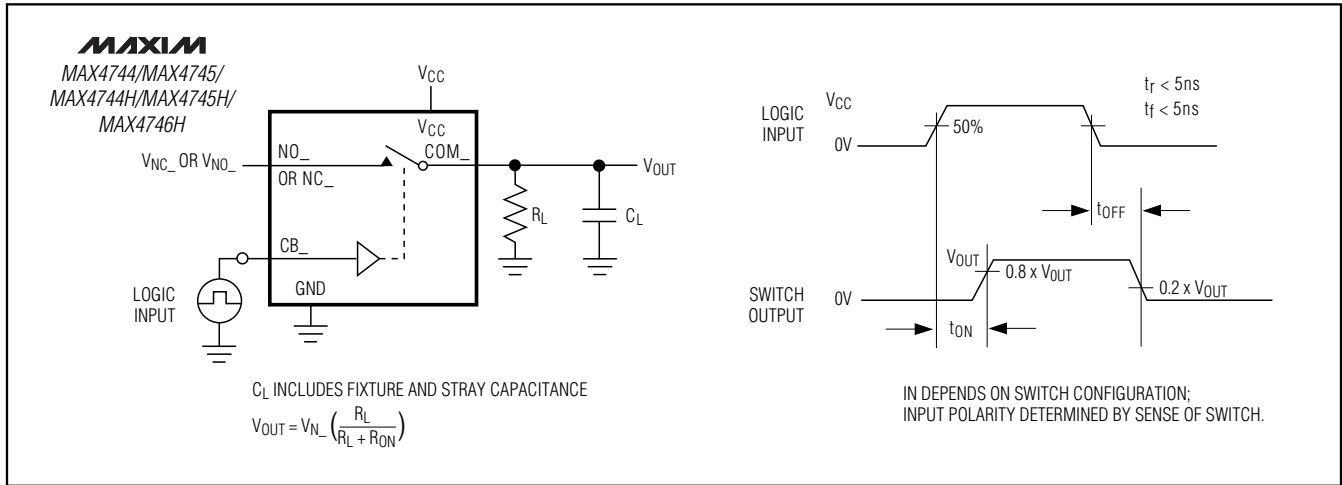

Figure 2. Switching Time

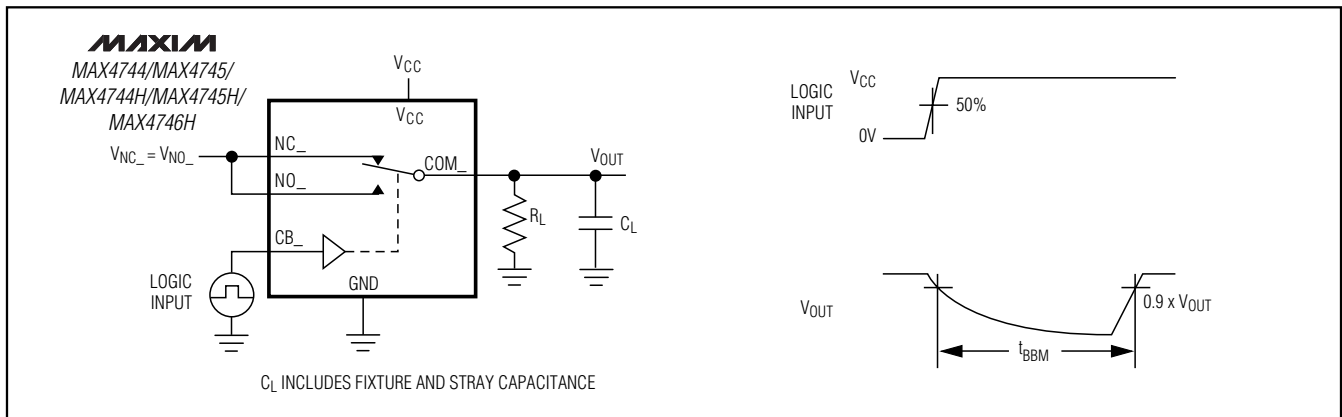

Figure 3. Break-Before-Make Interval

Analog Signal Levels

These devices pass signals from V_{CC} to as low as $V_{CC} - 5.5\text{V}$, including signals below ground with minimal distortion and very little change in on-resistance (see the *Typical Operating Characteristics*). The switches are bidirectional, so the NO_, NC_, and COM_ terminals can be used as either inputs or outputs.

COM_ Protection with $V_{CC} = 0\text{V}$ (MAX4744H/MAX4745H/MAX4746H)

This feature prevents any damage to the device due to improper power-supply sequencing. The protection applies if a signal is applied on COM_ when V_{CC} is less than 0.5V. The switch is not protected if V_{CC} goes above 0.5V due to parasitic capacitive coupling or any

leakage between COM_ and V_{CC} . The signal at COM_ ranges between $(V_{CC} - 6.0\text{V})$ to 6.0V under protection conditions.

Click-and-Pop Suppression

The MAX4744/MAX4744H have a shunt resistor on all their NO and NC terminals to automatically discharge any capacitance when they are not connected to COM. The shunt resistor reduces audible click-and-pop sounds that occur when switching between audio sources. Audible clicks and pops are caused when a step DC voltage is switched into the speaker. The DC step transients can be reduced by automatically discharging the side that is not connected to the COM terminal, reducing any residual DC voltage and reducing clicks and pops.

Low-Voltage, Dual SPDT, Audio Clickless Switches with Negative Rail Capability

Test Circuits/Timing Diagrams

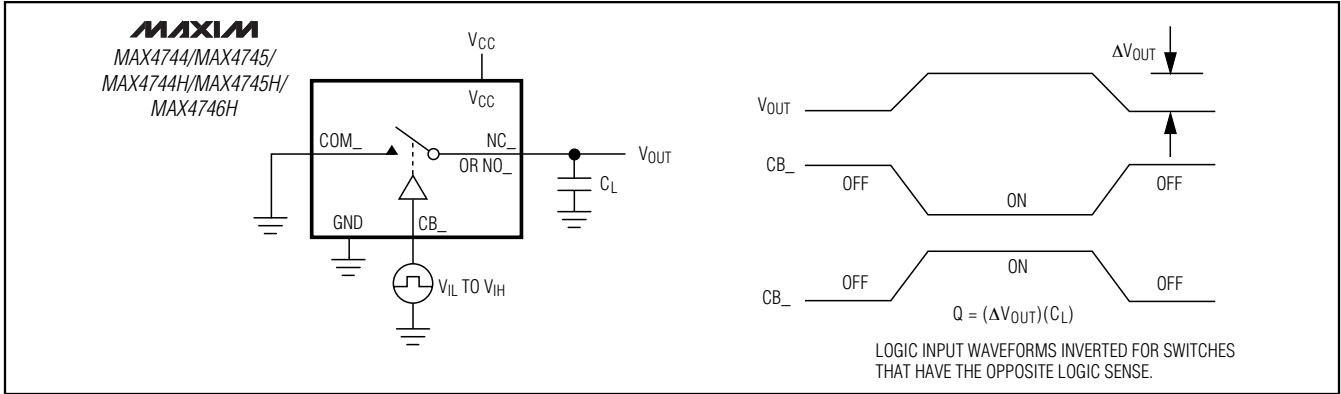

Figure 4. Charge Injection

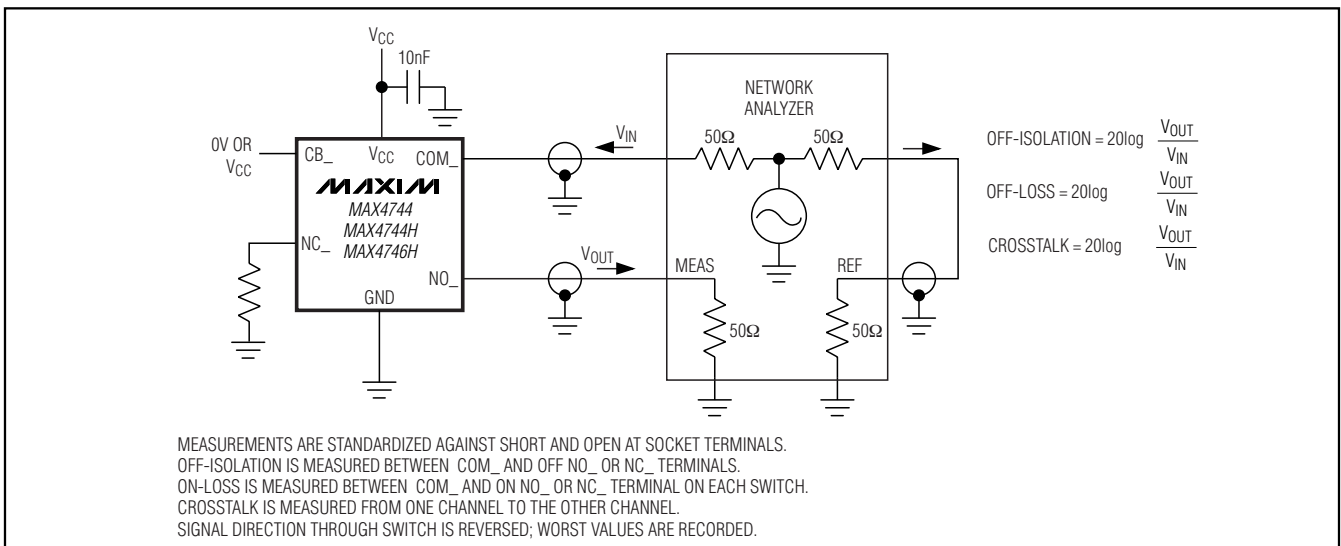

Figure 5. Off-Isolation, On-Loss, and Crosstalk

Break-Before-Make Switching

All devices feature break-before-make switching, which is configured to break (open) the first set of contacts before engaging (closing) the new contacts. This prevents the momentary connection of the old and new signal paths to the output, reducing click-and-pop sounds.

Power-Supply Sequencing and Overvoltage Protection

Caution: Do not exceed the Absolute Maximum Ratings since stresses beyond the listed ratings may cause permanent damage to the device.

Proper power-supply sequencing is recommended for all CMOS devices. Improper supply sequencing can force the switch into latch-up, causing it to draw excessive supply current. The only way out of latch-up is to recycle the power and reapply properly. Connect all ground pins first, then apply power to VCC, and finally apply signals to NO_, NC_, and COM_. Follow the reverse order upon power-down.

Low-Voltage, Dual SPDT, Audio Clickless Switches with Negative Rail Capability

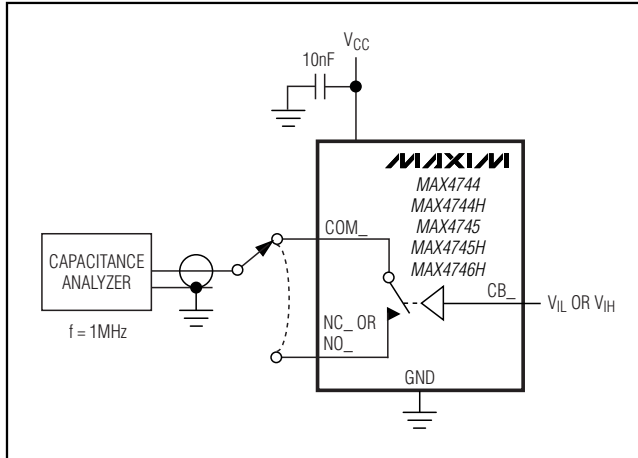
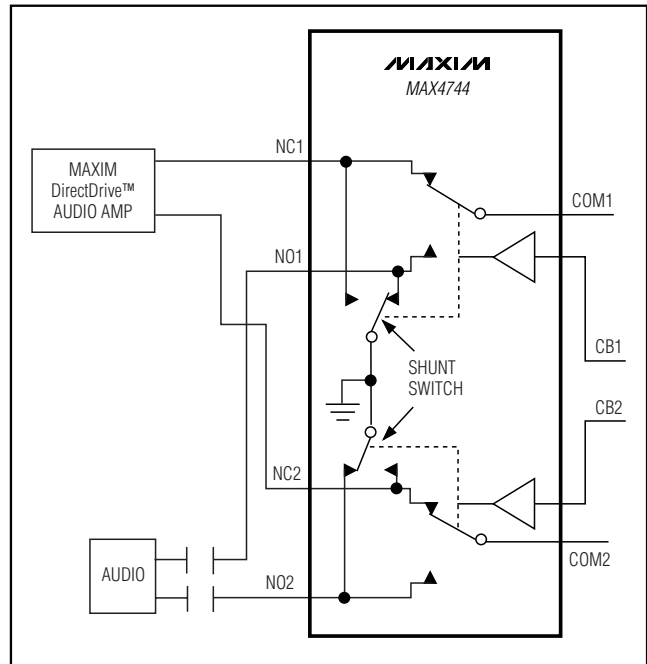

Figure 6. Channel Off-/On-Capacitance

Chip Information

PROCESS: BiCMOS

Typical Operating Circuit



MAX4744/MAX4744H/MAX4745/MAX4745H/MAX4746H

Low-Voltage, Dual SPDT, Audio Clickless Switches with Negative Rail Capability

Package Information

(The package drawing(s) in this data sheet may not reflect the most current specifications. For the latest package outline information, go to www.maxim-ic.com/packages.)

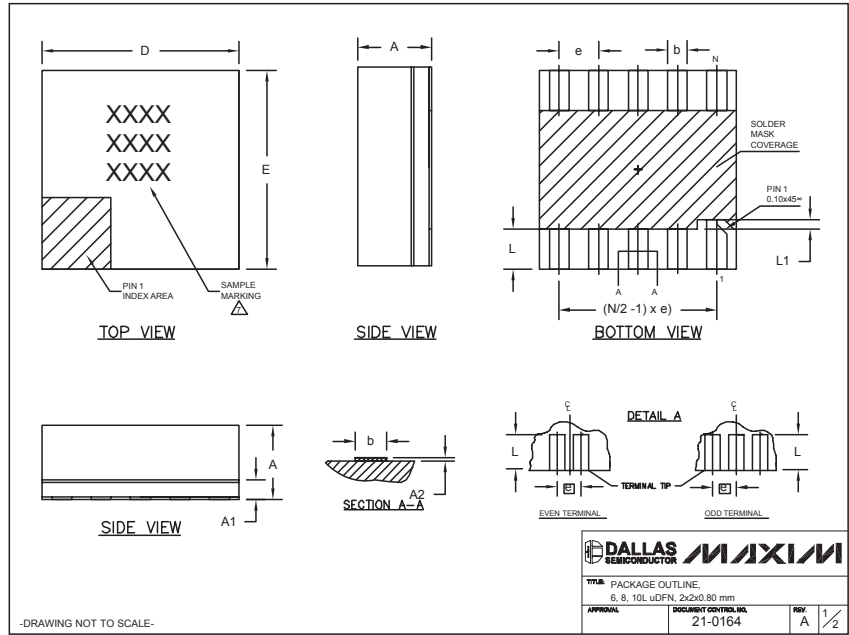

| COMMON DIMENSIONS | | | |
|-------------------|-----------|-------|-------|
| SYMBOL | MIN. | NOM. | MAX. |
| A | 0.70 | 0.75 | 0.80 |
| A1 | 0.15 | 0.20 | 0.25 |
| A2 | 0.020 | 0.025 | 0.035 |
| D | 1.95 | 2.00 | 2.05 |
| E | 1.95 | 2.00 | 2.05 |
| L | 0.30 | 0.40 | 0.50 |
| L1 | 0.10 REF. | | |

| PACKAGE VARIATIONS | | | | |
|--------------------|----|----------|-----------|-------------|
| PKG. CODE | N | e | b | (N/2-1) x e |
| L622-1 | 6 | 0.65 BSC | 0.30±0.05 | 1.30 REF. |
| L822-1 | 8 | 0.50 BSC | 0.25±0.05 | 1.50 REF. |
| L1022-1 | 10 | 0.40 BSC | 0.20±0.03 | 1.60 REF. |

NOTES:
 1. ALL DIMENSIONS ARE IN mm. ANGLES IN DEGREES.
 2. COPLANARITY SHALL NOT EXCEED 0.08mm.
 3. WARPAGE SHALL NOT EXCEED 0.10mm.
 4. PACKAGE LENGTH/PACKAGE WIDTH ARE CONSIDERED AS SPECIAL CHARACTERISTIC(S).
 5. "N" IS THE TOTAL NUMBER OF LEADS.
 6. NUMBER OF LEADS SHOWN ARE FOR REFERENCE ONLY.
 Δ MARKING IS FOR PACKAGE ORIENTATION REFERENCE ONLY.

| | | | |
|--|----------------------|--------------|-----|
| DALLAS SEMICONDUCTOR | | MAXIM | |
| TITLE PACKAGE OUTLINE, 6, 8, 10L uDFN, 2x2x0.80 mm | | | |
| APPROVAL | DOCUMENT CONTROL NO. | REV. | QTY |
| | 21-0164 | A | 1/2 |

-DRAWING NOT TO SCALE-

Maxim cannot assume responsibility for use of any circuitry other than circuitry entirely embodied in a Maxim product. No circuit patent licenses are implied. Maxim reserves the right to change the circuitry and specifications without notice at any time.

12 **Maxim Integrated Products, 120 San Gabriel Drive, Sunnyvale, CA 94086 408-737-7600**

Looking for pricing, stock, or lifecycle information?

Click below to explore more details on WIN SOURCE:

- ⊖ [View MAX4744HELB on WIN SOURCE](#)
- ⊖ [Maxim Integrated Information](#)

Optimize Your Supply Chain with WIN SOURCE Solutions

- ✓ Global Sourcing Solution
- ✓ Obsolete Management
- ✓ Cost Control Management
- ✓ Shortage Management
- ✓ Alternative Solution
- ✓ Excess Inventory Management