



**THE DATASHEET OF  
MAX4744ELB+T**





# Low-Voltage, Dual SPDT, Audio Clickless Switches with Negative Rail Capability

## General Description

The MAX4744/MAX4744H/MAX4745/MAX4745H/MAX4746H dual SPDT (single-pole/double-throw) audio switches feature negative signal capability that allows signals as low as  $V_{CC} - 5.5V$  to pass through without distortion. These analog switches have a low on-resistance and low supply current, and operate from a single +1.8V to +5.5V supply.

The MAX4744/MAX4744H have internal shunt resistors that automatically discharge the capacitance at the normally open (NO) and normally closed (NC) terminals when they are not connected. The MAX4746H features internal shunt resistors on NC\_ terminals. This reduces click-and-pop sounds that occur when switching audio signals between precharged points. A break-before-make feature further reduces popping. The MAX4744/MAX4745 control the switches with two control bits CB1 and CB2. The MAX4744H/MAX4745H/MAX4746H have one control bit to switch both switches and an enable input  $\overline{EN}$  to put the switches in a high-impedance mode. The MAX4744H/MAX4745H/MAX4746H also have an internal protection network against voltages applied to COM\_ when  $V_{CC} = 0V$ .

These devices are available in a space-saving 10-pin  $\mu$ DFN (2mm x 2mm) package and operate over the -40°C to +85°C extended temperature range.

## Applications

Speaker Switching  
Power Routing  
Cellular Phones  
MP3 Players  
PDAs and Other Handheld Devices  
Notebook Computers

## Features

- ◆ Distortion-Free Negative Signal Throughput Down to  $V_{CC} - 5.5V$
- ◆ Internal Shunt Resistor Reduces Click/Pop (MAX4744/MAX4744H)
- ◆ 0.6 $\Omega$  (typ) Low On-Resistance
- ◆ 0.1 $\Omega$  (max) Channel-to-Channel Matching
- ◆ 0.55 $\Omega$  (max) On-Resistance Flatness
- ◆ +1.8V to +5.5V Single-Supply Voltage
- ◆ 0.01% (typ) Total Harmonic Distortion
- ◆ -75dB (typ) Crosstalk (100kHz)
- ◆ -68dB (typ) Off-Isolation (100kHz)
- ◆ Available in 10-Pin  $\mu$ DFN Package (2mm x 2mm)

## Pin Configurations

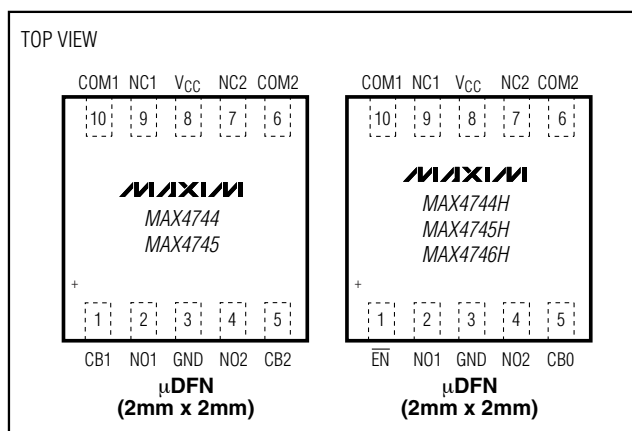

## Ordering Information/Selector Guide

PART	PIN-PACKAGE	TOP MARK	CLICKLESS	COM PROTECTION	PKG CODE
MAX4744ELB+T	10 $\mu$ DFN-10	+AAF	Yes	No	L1022-1
MAX4744HELB+T	10 $\mu$ DFN-10	+AAG	Yes	Yes	L1022-1
MAX4745ELB+T	10 $\mu$ DFN-10	+AAH	No	No	L1022-1
MAX4745HELB+T	10 $\mu$ DFN-10	+AAI	No	Yes	L1022-1
MAX4746HELB+T	10 $\mu$ DFN-10	+AAM	Yes, on NC_	Yes	L1022-1

**Note:** All devices are specified over the -40°C to +85°C operating temperature range.

+Denotes a lead-free package.



For pricing, delivery, and ordering information, please contact Maxim/Dallas Direct! at 1-888-629-4642, or visit Maxim's website at [www.maxim-ic.com](http://www.maxim-ic.com).

# Low-Voltage, Dual SPDT, Audio Clickless Switches with Negative Rail Capability

## ABSOLUTE MAXIMUM RATINGS

(All voltages referenced to GND.)

V <sub>CC</sub> , CB <sub>-</sub> , EN	.....-0.3V to +6.0V
NC <sub>-</sub> , NO <sub>-</sub>	.....(V <sub>CC</sub> - 6V) to (V <sub>CC</sub> + 0.3V)
COM <sub>-</sub> (MAX4744/MAX4745)	.....(V <sub>CC</sub> - 6V) to (V <sub>CC</sub> + 0.3V)
COM <sub>-</sub> (MAX4744H/MAX4745H/MAX4746H)	.....(Note 1)
Continuous Current NO <sub>-</sub> , NC <sub>-</sub> , COM <sub>-</sub>	.....±300mA
Peak Current NO <sub>-</sub> , NC <sub>-</sub> , COM <sub>-</sub> (pulsed at 1ms, 50% duty cycle)	.....±400mA

Peak Current NO <sub>-</sub> , NC <sub>-</sub> , COM <sub>-</sub> (pulsed at 1ms, 10% duty cycle)	.....±500mA
ESD Protection per Method 3015.7	
NO <sub>-</sub> , NC <sub>-</sub> , COM <sub>-</sub> , V <sub>CC</sub> , GND, CB <sub>-</sub> , EN	.....±2kV
Continuous Power Dissipation (T <sub>A</sub> = +70°C)	
10-Pin µDFN (derate 5mW/°C above +70°C)	.....403mW
Operating Temperature Range	.....-40°C to +85°C
Storage Temperature Range	.....-65°C to +150°C

**Note 1:** If V<sub>CC</sub> > 0.5V, limits are (V<sub>CC</sub> - 6V) to (V<sub>CC</sub> + 0.3V). If V<sub>CC</sub> < 0.5V, limits are (V<sub>CC</sub> - 6.0V) to +6.0V.

Stresses beyond those listed under "Absolute Maximum Ratings" may cause permanent damage to the device. These are stress ratings only, and functional operation of the device at these or any other conditions beyond those indicated in the operational sections of the specifications is not implied. Exposure to absolute maximum rating conditions for extended periods may affect device reliability.

## ELECTRICAL CHARACTERISTICS

(V<sub>CC</sub> = +2.7V to +5.5V, T<sub>A</sub> = -40°C to +85°C, unless otherwise noted. Typical values are at V<sub>CC</sub> = 3.3V, T<sub>A</sub> = +25°C.) (Note 2)

PARAMETER	SYMBOL	CONDITIONS	MIN	TYP	MAX	UNITS
<b>POWER SUPPLY</b>						
Supply-Voltage Range	V <sub>CC</sub>		1.8		5.5	V
Supply Current	I <sub>CC</sub>	V <sub>CC</sub> = 5.5V, V <sub>CB-</sub> = 0V or V <sub>CC</sub>		0.3	1	µA
		V <sub>CC</sub> = 5.5V, V <sub>CB-</sub> = 0.5V or 1.4V			8	
		V <sub>CC</sub> = 2.7V, V <sub>CB-</sub> = 0.5V or 1.4V			4	
<b>ANALOG SWITCH</b>						
Analog Signal Range	V <sub>NC-</sub> , V <sub>NO-</sub> , V <sub>COM-</sub>	(Note 3)	V <sub>CC</sub> - 5.5V		V <sub>CC</sub>	V
On-Resistance (Note 4)	R <sub>ON</sub>	V <sub>CC</sub> = +2.7V; V <sub>NC-</sub> or V <sub>NO-</sub> = V <sub>CC</sub> - 5.5V, -1V, 0V, 1V, 2V, V <sub>CC</sub> ; I <sub>COM-</sub> = 100mA	T <sub>A</sub> = +25°C	0.6	0.95	Ω
			T <sub>A</sub> = T <sub>MIN</sub> to T <sub>MAX</sub>		1.0	
On-Resistance Match Between Channels (Notes 4 and 5)	ΔR <sub>ON</sub>	V <sub>CC</sub> = 2.7V, V <sub>NC-</sub> or V <sub>NO-</sub> = 0V, I <sub>COM-</sub> = 100mA	T <sub>A</sub> = +25°C		0.1	Ω
			T <sub>A</sub> = T <sub>MIN</sub> to T <sub>MAX</sub>		0.1	
On-Resistance Flatness (Note 6)	R <sub>FLAT</sub>	V <sub>CC</sub> = +2.7V, V <sub>NC-</sub> or V <sub>NO-</sub> = V <sub>CC</sub> - 5.5V, -1V, 0V, 1V, 2V, V <sub>CC</sub> ; I <sub>COM-</sub> = 100mA	T <sub>A</sub> = +25°C		0.55	Ω
			T <sub>A</sub> = T <sub>MIN</sub> to T <sub>MAX</sub>		0.6	
Shunt Switch Resistance	R <sub>SH</sub>	MAX4744/MAX4744H/MAX4746H only, V <sub>CC</sub> = 2.7V	2		5	kΩ
NC <sub>-</sub> , NO <sub>-</sub> Off-Leakage Current (Note 3)	I <sub>NO-(OFF)</sub> , I <sub>NC-(OFF)</sub>	V <sub>CC</sub> = +2.7V switch open; V <sub>NC-</sub> or V <sub>NO-</sub> = -2.5V, +2.5V (MAX4745/MAX4745H only) (MAX4746H - I <sub>NO-(OFF)</sub> only)	T <sub>A</sub> = +25°C	-15	+15	nA
			T <sub>A</sub> = T <sub>MIN</sub> to T <sub>MAX</sub>	-50	+50	
COM <sub>-</sub> On-Leakage Current (Note 3)	I <sub>COM-(ON)</sub>	V <sub>CC</sub> = 2.7V switch closed; V <sub>NC-</sub> or V <sub>NO-</sub> = -2.5V, +2.5V; V <sub>COM-</sub> = -2.5V, +2.5V	T <sub>A</sub> = +25°C	-15	+15	nA
			T <sub>A</sub> = T <sub>MIN</sub> to T <sub>MAX</sub>	-100	+100	

# Low-Voltage, Dual SPDT, Audio Clickless Switches with Negative Rail Capability

## ELECTRICAL CHARACTERISTICS (continued)

( $V_{CC} = +2.7V$  to  $+5.5V$ ,  $T_A = -40^{\circ}C$  to  $+85^{\circ}C$ , unless otherwise noted. Typical values are at  $V_{CC} = 3.3V$ ,  $T_A = +25^{\circ}C$ .) (Note 2)

PARAMETER	SYMBOL	CONDITIONS		MIN	TYP	MAX	UNITS
COM_ Leakage Under Protection Conditions	$I_{L(Prot)}$	$V_{CC} = 0V$ ; $V_{COM\_} = +5.5V$ ; $V_{NC\_}$ and $V_{NO\_}$ are unconnected or connected to GND; $V_{CB\_} = 0V$ (MAX4744H/MAX4745H/MAX4746H only)	$T_A = +25^{\circ}C$		30		nA
			$T_A = T_{MIN}$ to $T_{MAX}$		500		
<b>DYNAMIC CHARACTERISTICS</b>							
Turn-On Time	$t_{ON}$	$V_{CC} = 2.7V$ , $R_L = 32\Omega$ , $C_L = 35pF$ , Figure 2	For NO_, $V_{NO\_} = 1.5V$ , $V_{CB\_} = 0V$ to $V_{CC}$		55		ns
			For NC_, $V_{NC\_} = 1.5V$ , $V_{CB\_} = V_{CC}$ to $0V$		560		
Turn-Off Time	$t_{OFF}$	$V_{CC} = 2.7V$ , $R_L = 32\Omega$ , $C_L = 35pF$ , Figure 2	For NO_, $V_{NO\_} = 1.5V$ , $V_{CB\_} = V_{CC}$ to $0V$		540		ns
			For NC_, $V_{NC\_} = 1.5V$ , $V_{CB\_} = 0V$ to $V_{CC}$		36		
Break-Before-Make Delay Time	$t_D$	$V_{CC} = 2.7V$ , $V_{NC\_} = V_{NO\_} = 1.5V$ ; for NO_, $V_{CB\_} = V_{CC}$ to $0V$ ; for NC_, $V_{CB\_} = 0V$ to $V_{CC}$ ; $R_L = 32\Omega$ ; $C_L = 35pF$ ; Figure 3			20		ns
Power-Supply Rejection Ratio	PSRR	$f = 100kHz$ , $V_{COM\_} = 1V_{RMS}$ , $R_L = 50\Omega$ , $C_L = 5pF$			52		dB
Charge Injection	Q	$V_{GEN\_} = 0V$ ; $R_{GEN} = 0\Omega$ , $C_L = 1nF$ , Figure 4			450		pC
Off-Isolation	$V_{ISO}$	$C_L = 5pF$ ; $R_L = 50\Omega$ ; $f = 100kHz$ ; $V_{COM\_} = 1V_{RMS}$ ; Figure 5 (Note 7)			-68		dB
Crosstalk	$V_{CT}$	$C_L = 5pF$ ; $R_L = 50\Omega$ ; $f = 100kHz$ ; $V_{COM\_} = 1V_{RMS}$ ; Figure 5			-75		dB
Total Harmonic Distortion	THD	$f = 20Hz$ to $20kHz$ , $V_{COM\_} = 0.5V_{P-P}$ , $R_L = 50\Omega$			0.01		%
NO_, NC_ Off-Capacitance	$C_{NO(OFF)}$ , $C_{NC(OFF)}$	$f = 1MHz$ , Figure 6			90		pF
COM On-Capacitance	$C_{COM(ON)}$	$f = 1MHz$ , Figure 6			300		pF

MAX4744/MAX4744H/MAX4745/MAX4745H/MAX4746H

# Low-Voltage, Dual SPDT, Audio Clickless Switches with Negative Rail Capability

## ELECTRICAL CHARACTERISTICS (continued)

( $V_{CC} = +2.7V$  to  $+5.5V$ ,  $T_A = -40^\circ C$  to  $+85^\circ C$ , unless otherwise noted. Typical values are at  $V_{CC} = 3.3V$ ,  $T_A = +25^\circ C$ .) (Note 2)

PARAMETER	SYMBOL	CONDITIONS	MIN	TYP	MAX	UNITS
<b>DIGITAL INPUTS (CB<sub>-</sub>, EN)</b>						
Input-Logic High	$V_{IH}$		1.4			V
Input-Logic Low	$V_{IL}$				0.5	V
Input Leakage Current	$I_{LEAK}$	$V_{CB-}$ or $V_{EN} = 0V$ or $V_{CC}$	-1		+1	$\mu A$

**Note 2:** All parameters are production tested at  $T_A = +25^\circ C$  and guaranteed by design over the specified temperature range.

**Note 3:** Signals on COM<sub>-</sub>, NO<sub>-</sub>, or NC<sub>-</sub> exceeding  $V_{CC}$  are clamped by internal diodes. Limit forward-diode current to maximum current ratings.

**Note 4:** Guaranteed by design; not production tested.

**Note 5:**  $\Delta R_{ON} = R_{ON(MAX)} - R_{ON(MIN)}$ .

**Note 6:** Flatness is defined as the difference between the maximum and minimum value of on-resistance as measured over the specified analog signal ranges.

**Note 7:** Off-isolation =  $20\log_{10}[V_{COM-} / V_{NO-}]$ ,  $V_{COM-}$  = output,  $V_{NO-}$  = input to off switch.

## Typical Operating Characteristics

( $V_{CC} = +3.3V$ ,  $T_A = +25^\circ C$ , unless otherwise noted.)

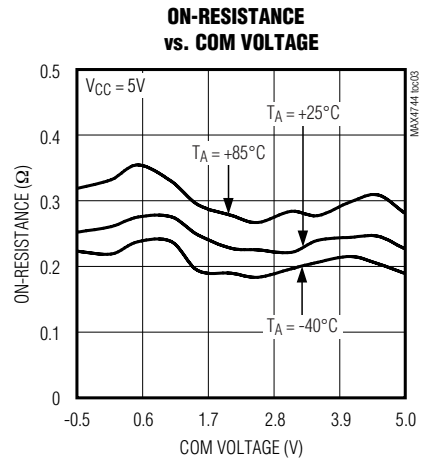
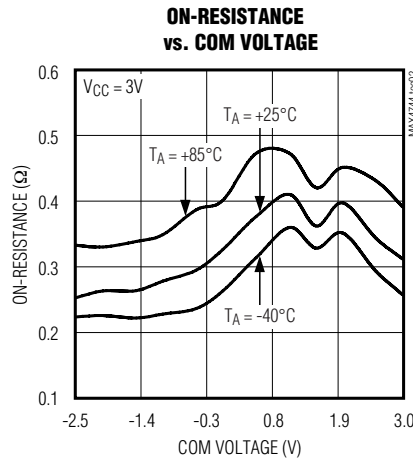
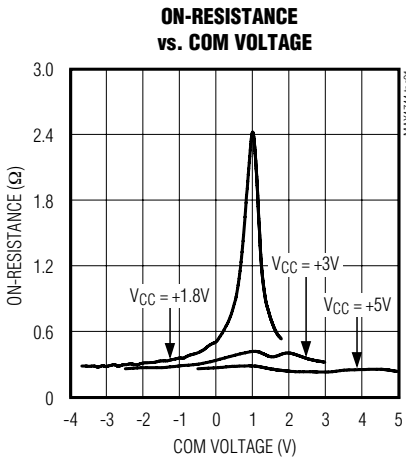

# Low-Voltage, Dual SPDT, Audio Clickless Switches with Negative Rail Capability

## Typical Operating Characteristics

( $V_{CC} = +3.3V$ ,  $T_A = +25^\circ C$ , unless otherwise noted.)

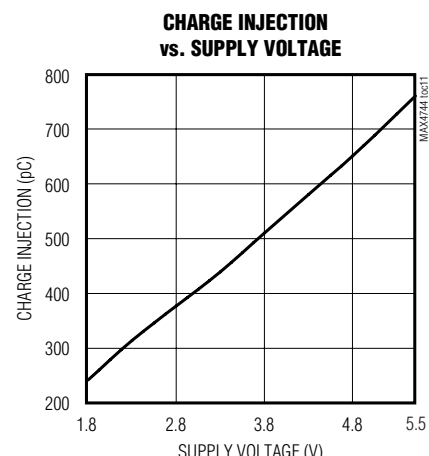
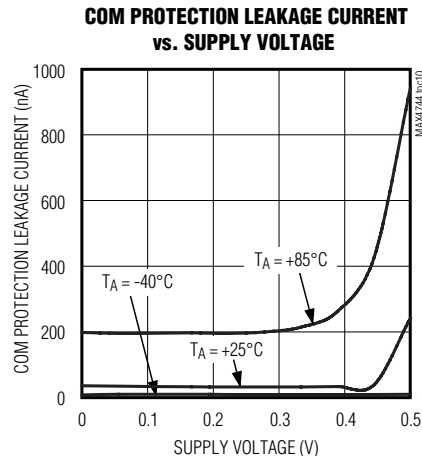
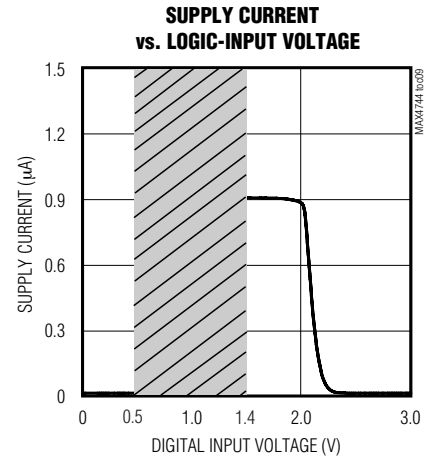
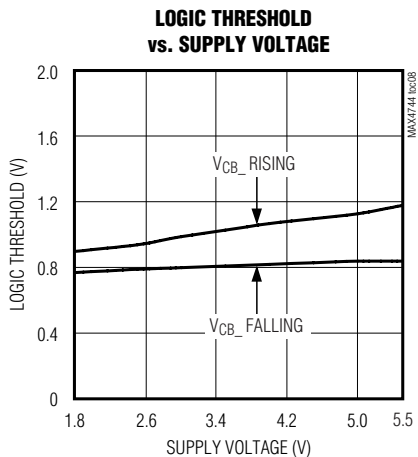
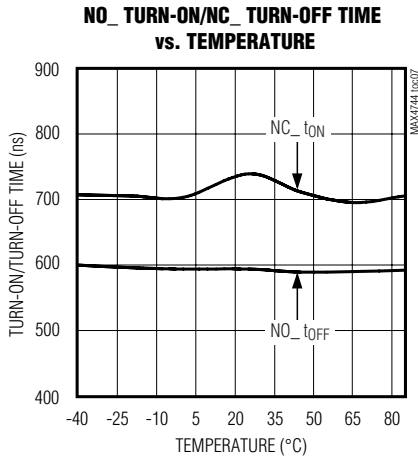
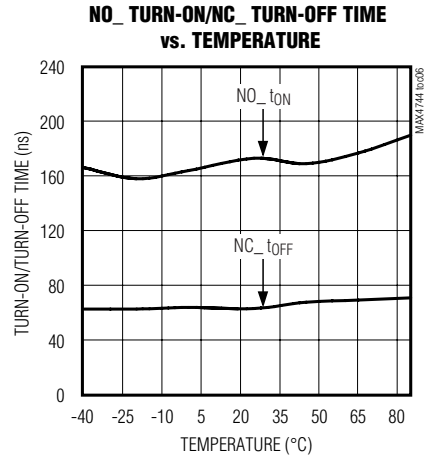
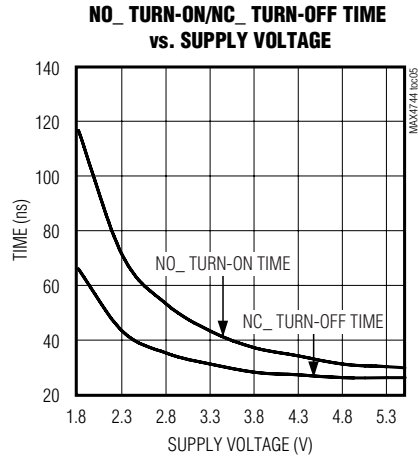
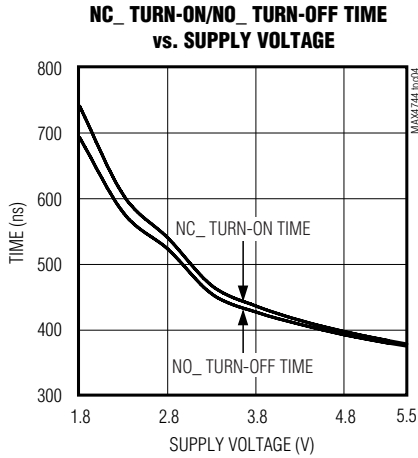

MAX4744/MAX4744H/MAX4745/MAX4745H/MAX4746H

# Low-Voltage, Dual SPDT, Audio Clickless Switches with Negative Rail Capability

## Typical Operating Characteristics (continued)

( $V_{CC} = +3.3V$ ,  $T_A = +25^\circ C$ , unless otherwise noted.)

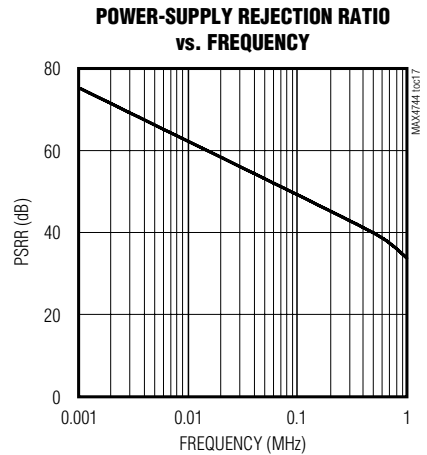
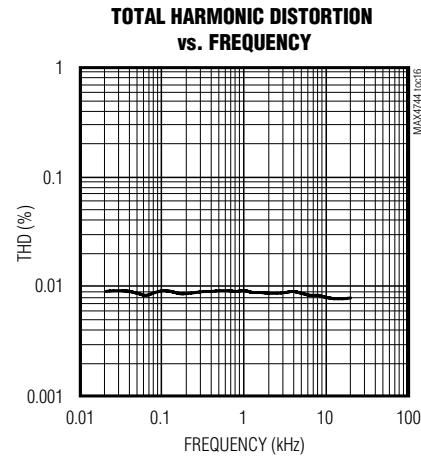
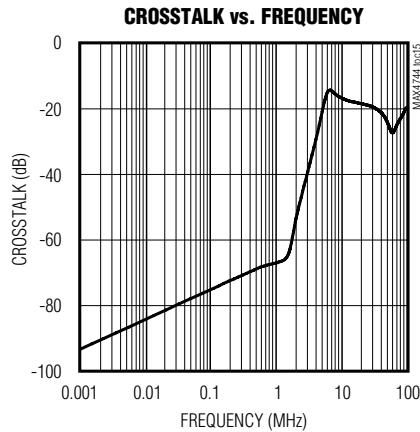
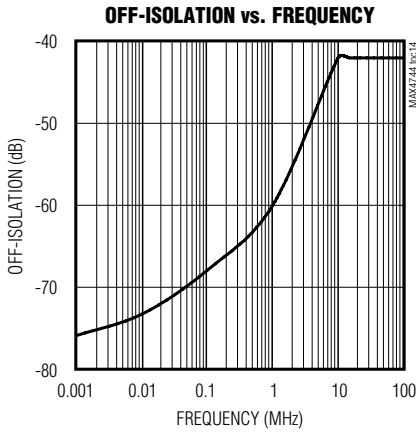
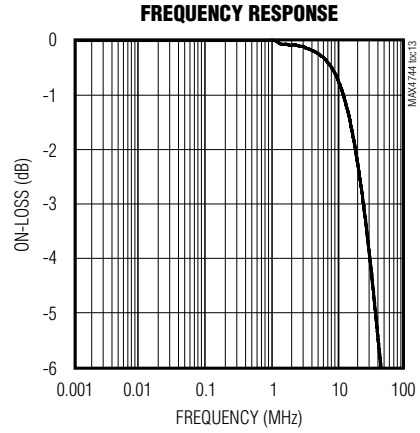
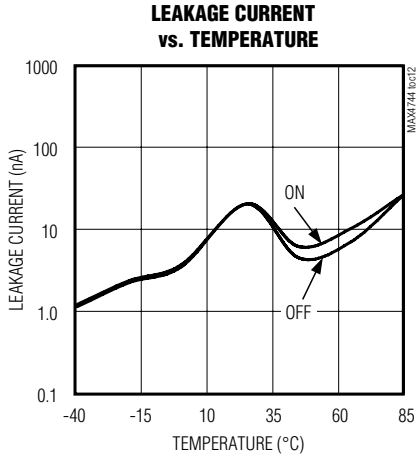

# Low-Voltage, Dual SPDT, Audio Clickless Switches with Negative Rail Capability

## Pin Description

PIN		NAME	FUNCTION
MAX4744/ MAX4745	MAX4744H/ MAX4745H/ MAX4746H		
1	—	CB1	Digital Control Input for Analog Switch 1
—	1	$\overline{EN}$	Enable Input. Driving $\overline{EN}$ high causes all switches to be high impedance. Pull $\overline{EN}$ low for normal operation.
2	2	NO1	Analog Switch 1—Normally Open Terminal
3	3	GND	Ground
4	4	NO2	Analog Switch 2—Normally Open Terminal
5	—	CB2	Digital Control Input for Analog Switch 2
—	5	CB0	Digital Control Input for Analog Switches 1 and 2
6	6	COM2	Analog Switch 2—Common Terminal
7	7	NC2	Analog Switch 2—Normally Closed Terminal
8	8	VCC	Positive Supply Voltage from +1.8V to +5.5V
9	9	NC1	Analog Switch 1—Normally Closed Terminal
10	10	COM1	Analog Switch 1—Common Terminal

## Detailed Description

The MAX4744/MAX4744H/MAX4745/MAX4745H/MAX4746H are low on-resistance, low-voltage, dual-SPDT analog switches that operate from a +1.8V to +5.5V single supply. These devices feature a negative signal capability that allows signals as low as VCC - 5.5V to pass through without distortion.

The MAX4744/MAX4745 feature two digital control bits to control each switch independently (see Table 1). The MAX4744H/MAX4745H/MAX4746H have one control bit to switch both switches and an enable input  $\overline{EN}$  to put the switches in a high-impedance mode. Driving  $\overline{EN}$  low takes the switches out of high impedance and CB0 controls both switches (see Table 2).

The MAX4744/MAX4744H have internal shunt resistors on all NO and NC terminals, and the MAX4746H has internal shunt resistors on NC terminals to suppress click-and-pop sounds that can occur when switching audio signals between precharged points.

## Applications Information

### Digital Control Inputs

The MAX4744/MAX4744H/MAX4745/MAX4745H/MAX4746H logic inputs accept up to +5.5V, regardless of supply voltage. For example, with a +3.3V supply, CB0, CB1, CB2, and  $\overline{EN}$  can be driven low to GND and

Table 1. MAX4744/MAX4745 Truth Table

CONTROL		SWITCH STATE	
CB1	CB2	Switch 1	Switch 2
0	0	Connected to NC1	Connected to NC2
0	1	Connected to NC1	Connected to NO2
1	0	Connected to NO1	Connected to NC2
1	1	Connected to NO1	Connected to NO2

Table 2. MAX4744H/MAX4745H/MAX4746H Truth Table

CONTROL		SWITCH STATE	
$\overline{EN}$	CB0	Switch 1	Switch 2
0	0	Connected to NC1	Connected to NC2
0	1	Connected to NO1	Connected to NO2
1	X	High Impedance	High Impedance

X = Don't Care

high to +5.5V, allowing for mixed logic levels in a system. Driving CB0, CB1, CB2, and  $\overline{EN}$  rail-to-rail minimizes power consumption.

MAX4744/MAX4744H/MAX4745/MAX4745H/MAX4746H

# Low-Voltage, Dual SPDT, Audio Clickless Switches with Negative Rail Capability

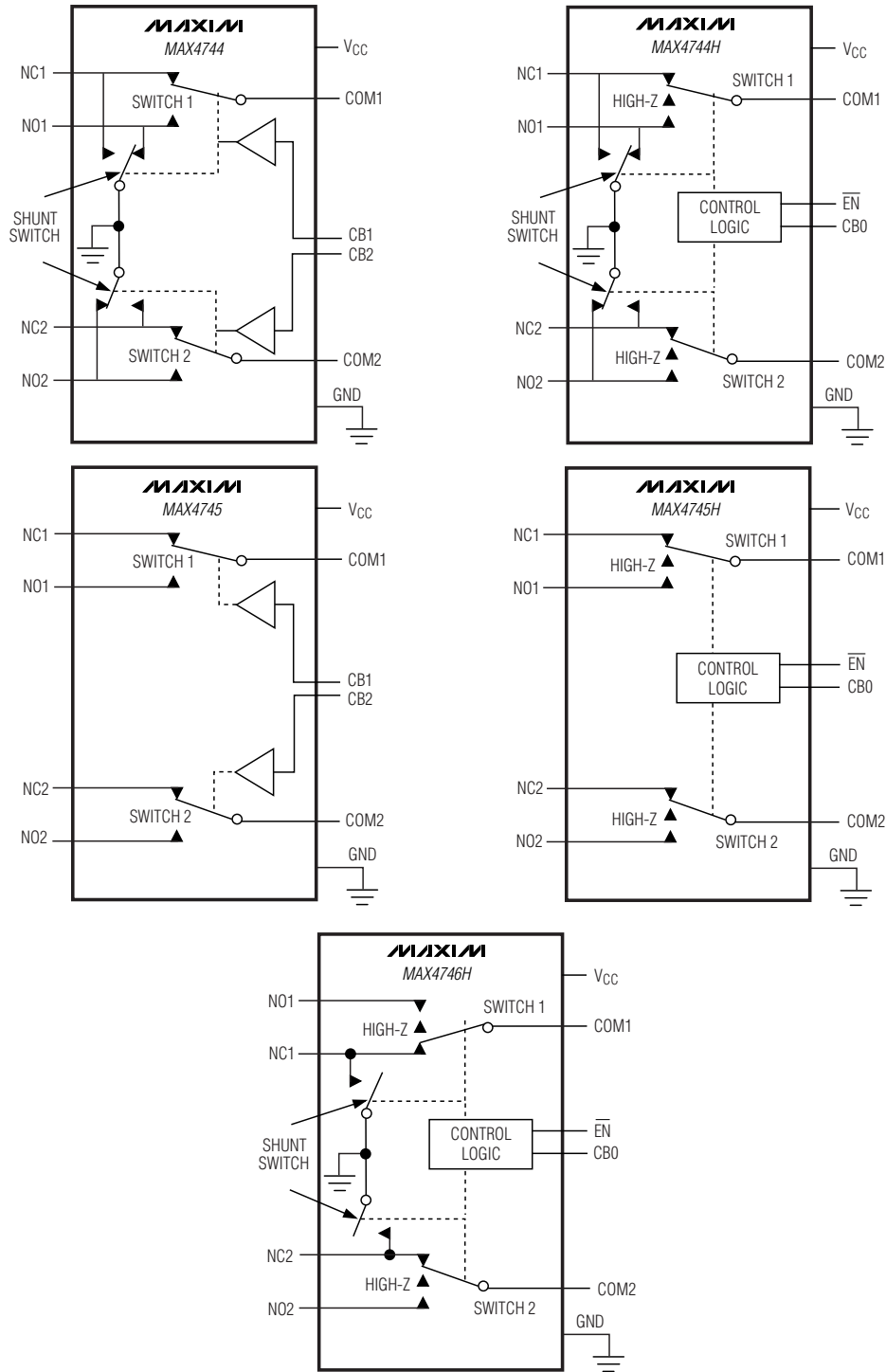

Figure 1. Functional Diagram

# Low-Voltage, Dual SPDT, Audio Clickless Switches with Negative Rail Capability

## Test Circuits/Timing Diagrams

MAX4744/MAX4744H/MAX4745/MAX4745H/MAX4746H

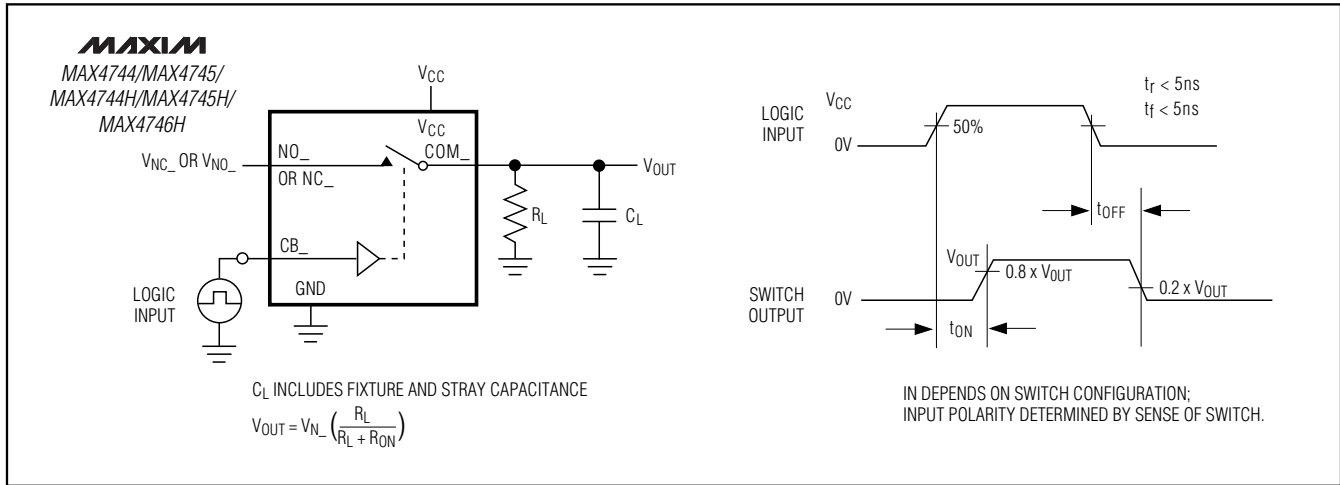

Figure 2. Switching Time

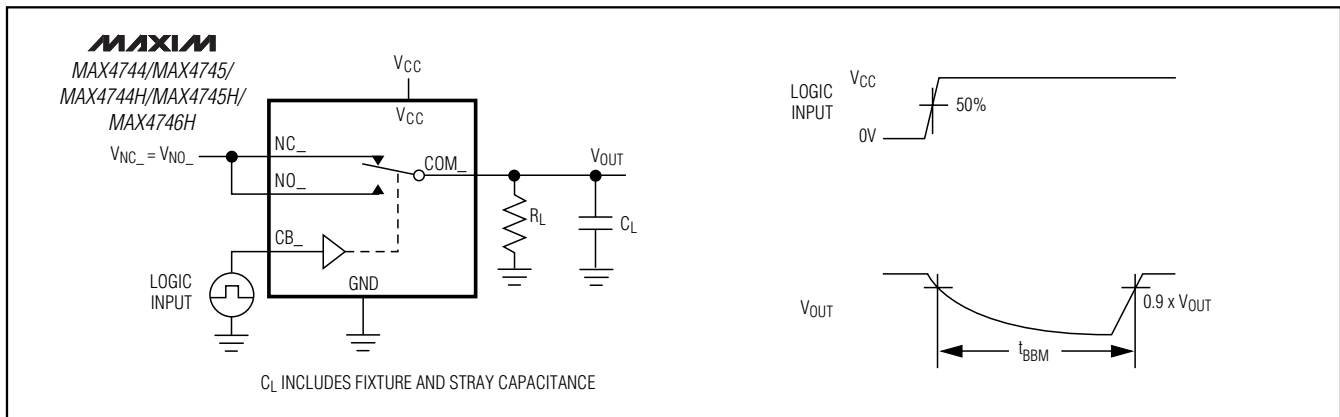

Figure 3. Break-Before-Make Interval

### Analog Signal Levels

These devices pass signals from  $V_{CC}$  to as low as  $V_{CC} - 5.5\text{V}$ , including signals below ground with minimal distortion and very little change in on-resistance (see the *Typical Operating Characteristics*). The switches are bidirectional, so the NO\_, NC\_, and COM\_ terminals can be used as either inputs or outputs.

### COM\_ Protection with $V_{CC} = 0\text{V}$ (MAX4744H/MAX4745H/MAX4746H)

This feature prevents any damage to the device due to improper power-supply sequencing. The protection applies if a signal is applied on COM\_ when  $V_{CC}$  is less than 0.5V. The switch is not protected if  $V_{CC}$  goes above 0.5V due to parasitic capacitive coupling or any

leakage between COM\_ and  $V_{CC}$ . The signal at COM\_ ranges between  $(V_{CC} - 6.0\text{V})$  to 6.0V under protection conditions.

### Click-and-Pop Suppression

The MAX4744/MAX4744H have a shunt resistor on all their NO and NC terminals to automatically discharge any capacitance when they are not connected to COM. The shunt resistor reduces audible click-and-pop sounds that occur when switching between audio sources. Audible clicks and pops are caused when a step DC voltage is switched into the speaker. The DC step transients can be reduced by automatically discharging the side that is not connected to the COM terminal, reducing any residual DC voltage and reducing clicks and pops.

# Low-Voltage, Dual SPDT, Audio Clickless Switches with Negative Rail Capability

## Test Circuits/Timing Diagrams

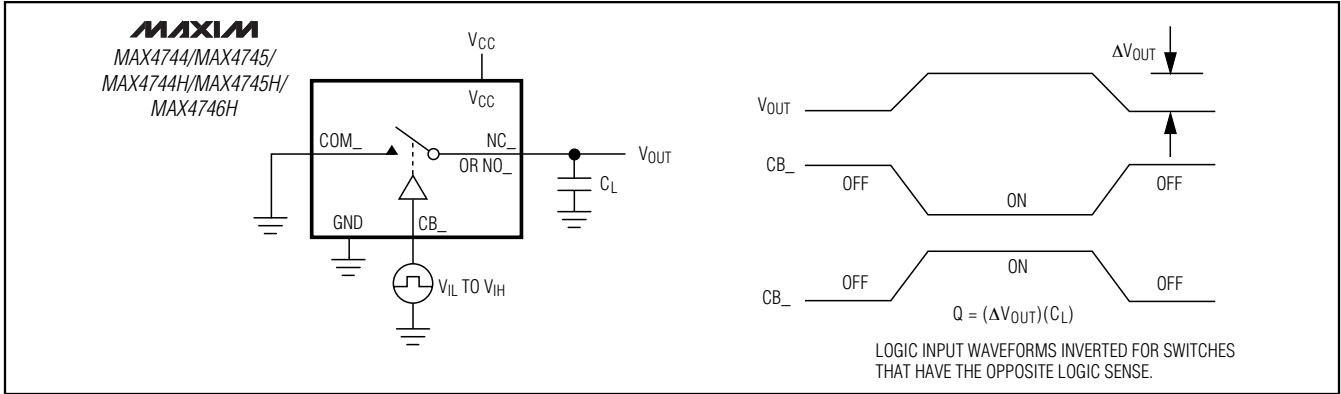

Figure 4. Charge Injection

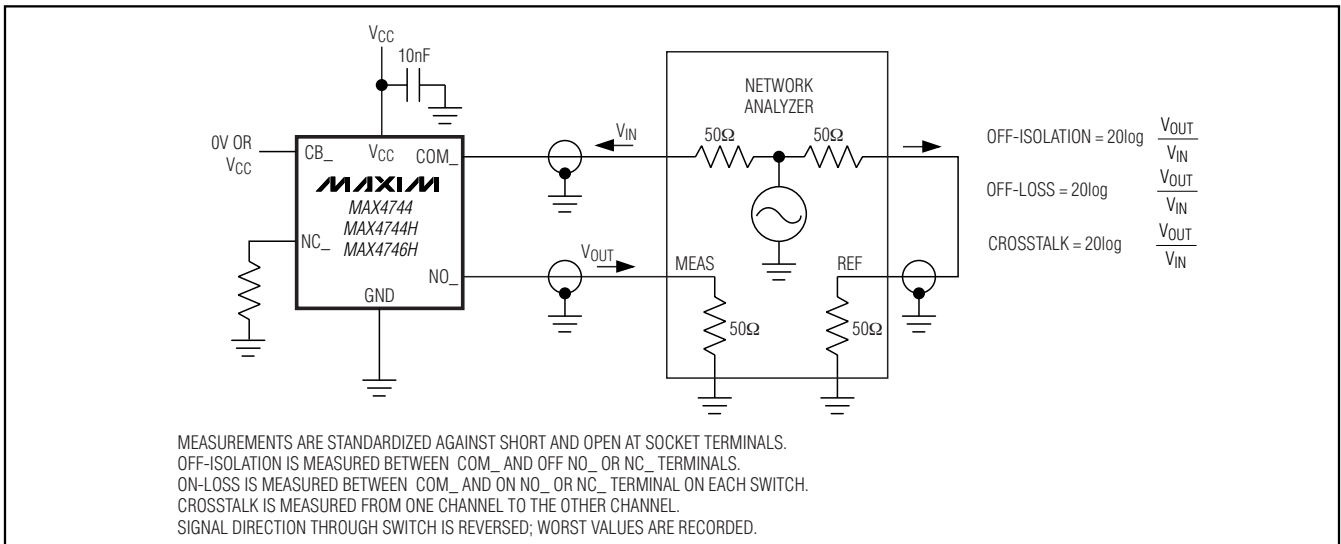

Figure 5. Off-Isolation, On-Loss, and Crosstalk

### Break-Before-Make Switching

All devices feature break-before-make switching, which is configured to break (open) the first set of contacts before engaging (closing) the new contacts. This prevents the momentary connection of the old and new signal paths to the output, reducing click-and-pop sounds.

### Power-Supply Sequencing and Overvoltage Protection

**Caution: Do not exceed the Absolute Maximum Ratings since stresses beyond the listed ratings may cause permanent damage to the device.**

Proper power-supply sequencing is recommended for all CMOS devices. Improper supply sequencing can force the switch into latch-up, causing it to draw excessive supply current. The only way out of latch-up is to recycle the power and reapply properly. Connect all ground pins first, then apply power to VCC, and finally apply signals to NO\_, NC\_, and COM\_. Follow the reverse order upon power-down.

# Low-Voltage, Dual SPDT, Audio Clickless Switches with Negative Rail Capability

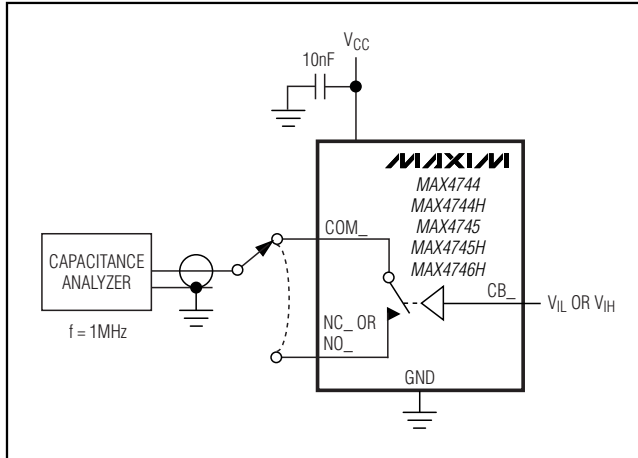
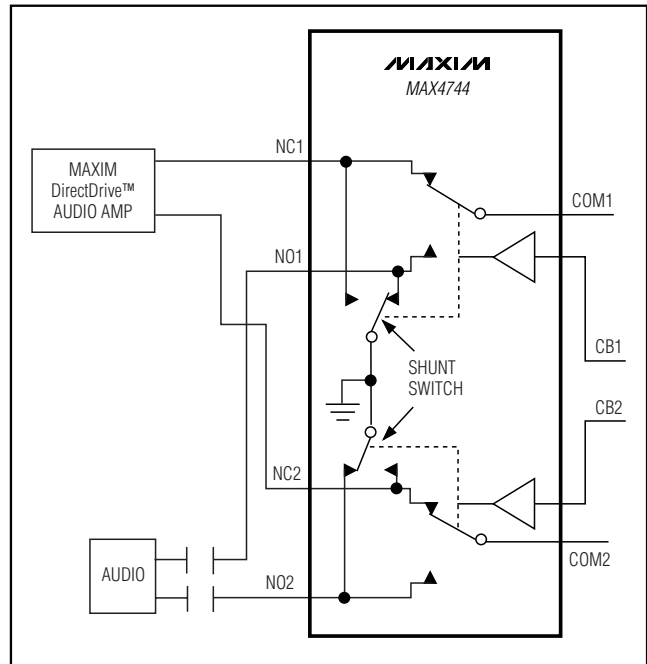

Figure 6. Channel Off-/On-Capacitance

## Chip Information

PROCESS: BiCMOS

## Typical Operating Circuit



MAX4744/MAX4744H/MAX4745/MAX4745H/MAX4746H

# Low-Voltage, Dual SPDT, Audio Clickless Switches with Negative Rail Capability

## Package Information

(The package drawing(s) in this data sheet may not reflect the most current specifications. For the latest package outline information, go to [www.maxim-ic.com/packages](http://www.maxim-ic.com/packages).)

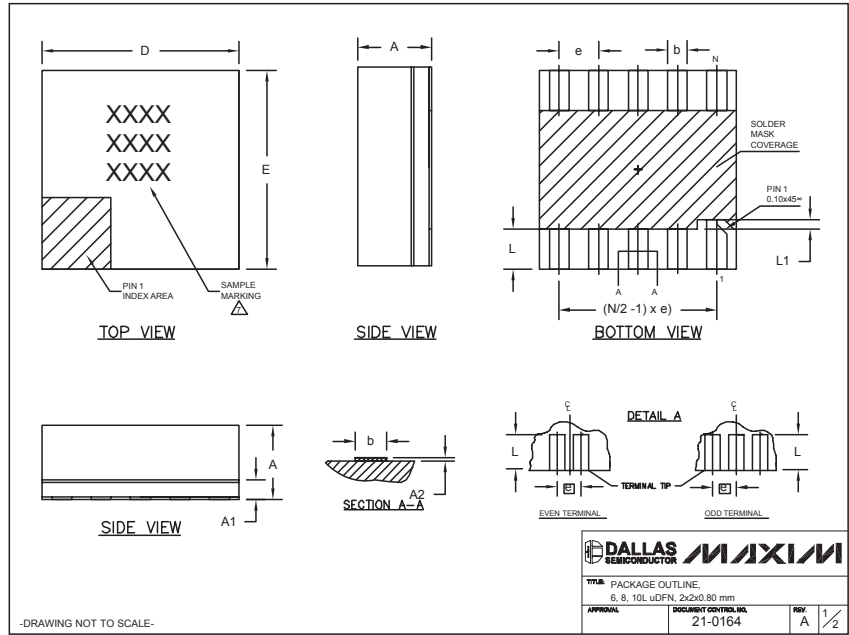

COMMON DIMENSIONS			
SYMBOL	MIN.	NOM.	MAX.
A	0.70	0.75	0.80
A1	0.15	0.20	0.25
A2	0.020	0.025	0.035
D	1.95	2.00	2.05
E	1.95	2.00	2.05
L	0.30	0.40	0.50
L1	0.10 REF.		

PACKAGE VARIATIONS				
PKG. CODE	N	e	b	(N/2 - 1) x e
L622-1	6	0.65 BSC	0.30±0.05	1.30 REF.
L822-1	8	0.50 BSC	0.25±0.05	1.50 REF.
L1022-1	10	0.40 BSC	0.20±0.03	1.60 REF.

NOTES:

- ALL DIMENSIONS ARE IN mm. ANGLES IN DEGREES.
- COPLANARITY SHALL NOT EXCEED 0.08mm.
- WARPAGE SHALL NOT EXCEED 0.10mm.
- PACKAGE LENGTH/PACKAGE WIDTH ARE CONSIDERED AS SPECIAL CHARACTERISTIC(S).
- "N" IS THE TOTAL NUMBER OF LEADS.
- NUMBER OF LEADS SHOWN ARE FOR REFERENCE ONLY.
- MARKING IS FOR PACKAGE ORIENTATION REFERENCE ONLY.

-DRAWING NOT TO SCALE-

DALLAS SEMICONDUCTOR		MAXIM	
TITLE	PACKAGE OUTLINE, 6, 8, 10L uDFN, 2x2x0.80 mm	REV	A 1/2
APPROVAL	DOCUMENT CONTROL, INC. 21-0164		

Maxim cannot assume responsibility for use of any circuitry other than circuitry entirely embodied in a Maxim product. No circuit patent licenses are implied. Maxim reserves the right to change the circuitry and specifications without notice at any time.

12 **Maxim Integrated Products, 120 San Gabriel Drive, Sunnyvale, CA 94086 408-737-7600**

## Looking for pricing, stock, or lifecycle information?

Click below to explore more details on WIN SOURCE:

 [View MAX4744ELB+T on WIN SOURCE](#)

 [Maxim Integrated](#) Information

## Optimize Your Supply Chain with WIN SOURCE Solutions

-  Global Sourcing Solution
-  Obsolete Management
-  Cost Control Management
-  Shortage Management
-  Alternative Solution
-  Excess Inventory Management