



**THE DATASHEET OF  
MAX4397DCTM+**



# Audio/Video Switch for Dual SCART Connectors

## General Description

The MAX4397DA/SA dual SCART switch matrices route audio and video signals between an MPEG encoder and two external SCART connectors under I<sup>2</sup>C control, and meets the requirements of EN50049-1, IEC 933-1, Canal+, and BSKyB standards.

The video and audio channels feature input source selection multiplexers, input buffers, and output buffers for routing all inputs to selected outputs. The MAX4397DA audio encoder input is differential DC-coupled, while the MAX4397SA audio encoder input is single-ended AC-coupled. Except for the MAX4397DA's audio encoder input, all other inputs and outputs are AC-coupled with internal DC-biasing set to predefined levels.

The MAX4397DA/SA provide programmable gain control from +5dB to +7dB in 1dB steps for Red, Green, and Blue component video signals. All other video outputs have a fixed +6dB gain. Additional features include an internal Luma and Chroma (Y/C) mixer that generates a Composite video signal (CVBS) to supply an RF modulator output and internal video reconstruction low-pass filters with passband ripple between -1dB and +1dB from 100kHz to 5.5MHz. The MAX4397DA/SA TV audio channel feature clickless switching and programmable volume control from -56dB to +6dB in 2dB steps. The VCR audio output also has programmable gain for -6dB, 0dB, or +6dB. The device also generates monaural audio from left and right stereo inputs. All audio drivers deliver a 3.0V<sub>RMS</sub> minimum output.

The MAX4397DA/SA operate with standard 5V and 12V power supplies and support slow-switching and fast-switching signals. The I<sup>2</sup>C interface programs the gain and volume control, and selects the input source for routing.

The MAX4397DA/SA are available in a compact 48-pin thin QFN package and are specified over the 0°C to +70°C commercial temperature range.

## Applications

Satellite Set-Top Boxes  
Cable Set-Top Boxes  
TVs  
VCRs  
DVDs

## Features

- ◆ Video Outputs Drive 2V<sub>p-p</sub> into 150Ω
- ◆ Audio Outputs Drive 3V<sub>RMS</sub> into 10kΩ
- ◆ Clickless, Popless Audio Gain Control and Switching
- ◆ AC-Coupled Video Inputs with Internal Clamp and Bias
- ◆ DC-Coupled Video Outputs
- ◆ Composite Video Signal Created Internally from Y/C Inputs
- ◆ Internal Video Reconstruction Filters Provide -40dB at 27MHz
- ◆ Differential (MAX4397DA) or Single-Ended (MAX4397SA) Audio Encoder Input
- ◆ Red/Chroma Switch for Bidirectional I/O
- ◆ I<sup>2</sup>C-Programmable RGB Gain from +5dB to +7dB
- ◆ I<sup>2</sup>C-Programmable Audio Gain Control from +6dB to -56dB
- ◆ Meets EN50049-1, IEC 933-1, Canal+, and BSKyB Requirements

## Ordering Information

PART	TEMP RANGE	PIN-PACKAGE	PKG CODE
MAX4397DACTM	0°C to +70°C	48 Thin QFN-EP* (7mm x 7mm)	T4877-6
MAX4397SACTM	0°C to +70°C	48 Thin QFN-EP* (7mm x 7mm)	T4877-6

\*EP = Exposed paddle.

Pin Configuration and Typical Application Circuits appear at end of data sheet.

System Block Diagram appears at end of data sheet.

# Audio/Video Switch for Dual SCART Connectors

## ABSOLUTE MAXIMUM RATINGS

V <sub>VID</sub> to GNDVID.....	-0.3V to +6V
V <sub>12</sub> to GNDAUD .....	-0.3V to +14V
V <sub>AUD</sub> to GNDAUD .....	-0.3V to +6V
GNDAUD to GNDVID .....	-0.1V to +0.1V
All Video Inputs, ENCIN_FS, VCRIN_FS, SET to GNDVID.....	-0.3V to (V <sub>VID</sub> + 0.3V)
All Audio Inputs, AUDBIAS to GNDAUD .....	-0.3V to (V <sub>AUD</sub> + 0.3V)
SDA, SCL, DEV_ADDR to GNDVID .....	-0.3V to +6V
All Audio Outputs, TV_SS, VCR_SS to GNDAUD.....	-0.3V to (V <sub>12</sub> + 0.3V)

All Video Outputs, TVOUT_FS to V <sub>VID</sub> , V <sub>AUD</sub> , GNDAUD, GNDVID .....	Continuous
All Audio Outputs to V <sub>VID</sub> , V <sub>AUD</sub> , V <sub>12</sub> , GNDVID, GNDAUD .....	Continuous
Continuous Power Dissipation (T <sub>A</sub> = +70°C) 48-Pin Thin QFN (derate 27mW/°C above +70°C).....	2105.3mW
Operating Temperature Range.....	0°C to +70°C
Junction Temperature .....	+150°C
Storage Temperature Range .....	-65°C to +150°C
Lead Temperature (soldering, 10s) .....	+300°C

Stresses beyond those listed under "Absolute Maximum Ratings" may cause permanent damage to the device. These are stress ratings only, and functional operation of the device at these or any other conditions beyond those indicated in the operational sections of the specifications is not implied. Exposure to absolute maximum rating conditions for extended periods may affect device reliability.

## ELECTRICAL CHARACTERISTICS

(V<sub>12</sub> = 12V, V<sub>VID</sub> = V<sub>AUD</sub> = 5V, 0.1μF X5R capacitor in parallel with a 10μF aluminum electrolytic capacitor from V<sub>AUD</sub> to GNDAUD, V<sub>12</sub> to GNDAUD, and V<sub>VID</sub> to GNDVID, SET = 100kΩ nominal, R<sub>LOAD</sub> = 150Ω, T<sub>A</sub> = 0°C to +70°C, unless otherwise noted. Typical values are at T<sub>A</sub> = +25°C.) (Note 1)

PARAMETER	SYMBOL	CONDITIONS	MIN	TYP	MAX	UNITS
V <sub>VID</sub> Supply Voltage Range	V <sub>VID</sub>	Inferred from video gain test at 4.75V and 5.2V	4.75	5.0	5.25	V
V <sub>AUD</sub> Supply Voltage Range	V <sub>AUD</sub>	Inferred from audio gain test at 4.75V and 5.2V	4.75	5.0	5.25	V
V <sub>12</sub> Supply Voltage Range	V <sub>12</sub>	Inferred from slow switching levels	11.4	12.0	12.6	V
V <sub>VID</sub> Quiescent Supply Current	I <sub>VID_Q</sub>	All video output amplifiers are enabled, no load		69	100	mA
V <sub>VID</sub> Standby Supply Current	I <sub>VID_S</sub>	All video output amplifiers are in shutdown, and TV_FS_OUT driver is in shutdown, no load		40	60	mA
V <sub>AUD</sub> Quiescent Supply Current	I <sub>AUD_Q</sub>	No load		2.4	6	mA
V <sub>12</sub> Quiescent Supply Current	I <sub>12_Q</sub>	No load		3.6	6	mA
<b>VIDEO CHARACTERISTICS</b>						
Voltage Gain	G <sub>V</sub>	CVBS and Y/C, 1V <sub>P-P</sub> input	+5.5	+6.0	+6.5	dB
		R,G,B, 1V <sub>P-P</sub> input, (programmable gain control)	+4.5	+5.0	+5.5	
			+5.5	+6.0	+6.5	
			+6.5	+7.0	+7.5	
LP Filter Passband Flatness		T <sub>A</sub> = +25°C, f = 5.5MHz, V <sub>IN</sub> = 1V <sub>P-P</sub>	-1	-0.52	+1	dB
LP Filter Attenuation at 27MHz		T <sub>A</sub> = +25°C, f = 27MHz, V <sub>IN</sub> = 1V <sub>P-P</sub>	30	40		dB
Slew Rate	SR	V <sub>OUT</sub> = 2V <sub>P-P</sub>		16		V/μs
Settling Time	t <sub>S</sub>	V <sub>OUT</sub> = 2V <sub>P-P</sub> , settle to 0.1% (Note 2)		300		ns
Gain Matching	AG	1V <sub>P-P</sub> input, between RGB or Y/C	-0.5		+0.5	dB
Differential Gain	DG	5-step modulated staircase		0.4		%
Differential Phase	DP	5-step modulated staircase		0.2		degrees
Signal-to-RMS Noise	SNR <sub>V</sub>	V <sub>IN</sub> = 1V <sub>P-P</sub>		65		dB

# Audio/Video Switch for Dual SCART Connectors

## ELECTRICAL CHARACTERISTICS (continued)

( $V_{12} = 12V$ ,  $V_{VID} = V_{AUD} = 5V$ ,  $0.1\mu F$  X5R capacitor in parallel with a  $10\mu F$  aluminum electrolytic capacitor from  $V_{AUD}$  to GND<sub>AUD</sub>,  $V_{12}$  to GND<sub>AUD</sub>, and  $V_{VID}$  to GND<sub>VID</sub>, SET = 100k $\Omega$  nominal,  $R_{LOAD} = 150\Omega$ ,  $T_A = 0^\circ C$  to  $+70^\circ C$ , unless otherwise noted. Typical values are at  $T_A = +25^\circ C$ .) (Note 1)

PARAMETER	SYMBOL	CONDITIONS	MIN	TYP	MAX	UNITS
Group Delay Variation	$\Delta GD$	$f = 0.1MHz$ to $4.43MHz$		8		nS
		$f = 0.1MHz$ to $5.5MHz$		12		
Sync-Tip Clamp Level	$V_{CLMP}$	RGB, Composite, and Luma input, no signal, no load		1.21		V
Chroma Bias	$V_{BIAS}$	Chroma input only, no signal, no load		1.9		V
Droop	D	Set by input current	-2		+2	%
Power-Supply Rejection Ratio	PSRR <sub>V</sub>	DC, $0.5V_{P-P}$		48		dB
Input Impedance	$Z_{IN}$	CVBS, Y, or RGB video inputs, $V_{IN} > V_{CLMP}$		4		M $\Omega$
		Chroma video input, $V_{IN} = V_{BIAS}$		11		k $\Omega$
Input Clamp Current	$I_{CLMP}$	$V_{IN} = 1.75V$	2.5	5	8.0	$\mu A$
Pulldown Resistance	$R_P$	Enable VCR <sub>R/C_OUT</sub> and TV <sub>R/C_OUT</sub> pulldown through I <sup>2</sup> C, (see registers 7 and 9 for loading register details)		10		$\Omega$
Output Pin Bias Voltage	$V_{OUT}$	RGB, Composite, and Luma, no signal, no load		1.08		V
		Chroma, no signal, no load		2.27		
Crosstalk	XTLK	Between any two active inputs, $f = 4.43MHz$ , $V_{IN} = 1V_{P-P}$		-50		dB
Mute Suppression	$M_{SPR_V}$	$f = 4.43MHz$ , $V_{IN} = 1V_{P-P}$ , on one input only		-50		dB
<b>AUDIO CHARACTERISTICS (Note 3)</b>						
Voltage Gain (From Application Input)	$G_A$	TV or VCR to stereo, gain = 0dB, $V_{IN} = 1V_{P-P}$	-0.5	0	+0.5	dB
		TV or VCR to mono, gain = 0dB, $V_{IN} = 1V_{P-P}$	2.5	3	3.5	
		ENC to stereo, gain = 0dB, $V_{IN} = 1V_{P-P}$	3.02	3.52	4.02	
		ENC to mono, gain = 0dB, $V_{IN} = 1V_{P-P}$	6.02	6.52	7.02	
Gain Matching Between Channels	$\Delta G_A$	Gain = 0dB, $V_{IN} = 1V_{P-P}$	-0.5	0	+0.5	dB
Flatness	$\Delta A$	$f = 20Hz$ to $20kHz$ , $0.5V_{RMS}$ input, gain = 0dB		0.01		dB
Frequency Bandwidth	BW	$0.5V_{RMS}$ input, frequency where output is -3dB referenced to 1kHz		230		kHz
Input DC Level (Excluding Encoder Inputs that are High Impedance)	$V_{IN}$	Gain = 0dB		$0.2308 \times V_{12}$		V
Encoder Input Common-Mode Voltage Range	$V_{CM}$	MAX4397DA only, input differential signal = 0V	1.2		$V_{AUD} - 0.7$	V

# Audio/Video Switch for Dual SCART Connectors

## ELECTRICAL CHARACTERISTICS (continued)

( $V_{12} = 12V$ ,  $V_{VID} = V_{AUD} = 5V$ , 0.1 $\mu F$  X5R capacitor in parallel with a 10 $\mu F$  aluminum electrolytic capacitor from  $V_{AUD}$  to GND<sub>AUD</sub>,  $V_{12}$  to GND<sub>AUD</sub>, and  $V_{VID}$  to GND<sub>VID</sub>, SET = 100k $\Omega$  nominal,  $R_{LOAD} = 150\Omega$ ,  $T_A = 0^\circ C$  to  $+70^\circ C$ , unless otherwise noted. Typical values are at  $T_A = +25^\circ C$ .) (Note 1)

PARAMETER	SYMBOL	CONDITIONS	MIN	TYP	MAX	UNITS
Encoder Common-Mode Rejection Ratio	CMRR	MAX4397DA only, over $V_{CM}$ range		40		dB
Input Signal Amplitude	$V_{IN\_AC}$	Single-ended inputs, $f = 1kHz$ , THD < 1%		3		$V_{RMS}$
		ENC inputs differential level, MAX4397DA, $f = 1kHz$ , THD < 1%		2.08		
		ENC inputs single-ended, MAX4397SA, $f = 1kHz$ , THD < 1%		1.31		
Input Resistance (Measured at Parts Input)	$R_{IN}$	Single ended: VCR_IN <sub>R</sub> , VCR_IN <sub>L</sub> , TV_IN <sub>R</sub> , TV_IN <sub>L</sub>		0.1		M $\Omega$
		Encoder, MAX4397DA: ENC_IN <sub>L+</sub> , ENC_IN <sub>L-</sub> , ENC_IN <sub>R+</sub> , ENC_IN <sub>R-</sub>		1		
		Encoder, MAX4397SA: ENC_IN <sub>L</sub> , ENC_IN <sub>R</sub>		0.1		
Output DC Level	$V_{OUT\_DC}$	$V_{IN} = 0V$		0.5 x $V_{12}$		V
Signal-to-Noise Ratio	SNR <sub>A</sub>	$f = 1.0kHz$ , 1 $V_{RMS}$ application input, gain = 0dB, 20Hz to 20kHz		95		dB
Total Harmonic Distortion Plus Noise	THD+N	$R_{LOAD} = 10k\Omega$ , $f = 1.0kHz$ , 0.5 $V_{RMS}$ output		0.004		%
		$R_{LOAD} = 10k\Omega$ , $f = 1.0kHz$ , 2 $V_{RMS}$ output		0.004		
Output Impedance	Z <sub>O</sub>	$f = 1kHz$		1		$\Omega$
Volume Attenuation Step	ASTEP	1.414 $V_{P-P}$ input, programmable gain to TV SCART volume control range extends from -56dB to +6dB	1.5	2	2.5	dB
		1.414 $V_{P-P}$ input, programmable gain to VCR audio extends from -6dB to +6dB	5.5	6	6.5	
Power-Supply Rejection Ratio	PSRR <sub>A</sub>	From $V_{12}$ , $f = 1kHz$ , 0.5 $V_{P-P}$ , (C <sub>AUD_BIAS</sub> = 47 $\mu F$ ), gain = 0dB		75		dB
		From $V_{AUD}$ , $f = 1kHz$ , 0.5 $V_{P-P}$ , $V_{AUD} \geq +4.75V$ , $V_{AUD} \leq +5.25V$ , gain = 0dB		75		
Mute Suppression	M <sub>SPR_A</sub>	$f = 1kHz$ , 0.5 $V_{RMS}$ input, set through I <sup>2</sup> C, see register 1 for loading register details		90		dB
Audio Clipping Level	V <sub>CLIP</sub>	$f = 1kHz$ , 2.5 $V_{RMS}$ input, gain = 6dB, THD < 1%		3.6		$V_{RMS}$
Left-to-Right Crosstalk	XTLK_LR	$f = 1kHz$ , 0.5 $V_{RMS}$ input, gain = 0dB		80		dB
Crosstalk	XTLK_CC	TV SCART to VCR SCART or VCR SCART to TV SCART, $f = 1kHz$ , 0.5 $V_{RMS}$ input, gain = 0dB		90		dB

# Audio/Video Switch for Dual SCART Connectors

## ELECTRICAL CHARACTERISTICS (continued)

( $V_{12} = 12V$ ,  $V_{VID} = V_{AUD} = 5V$ , 0.1 $\mu F$  X5R capacitor in parallel with a 10 $\mu F$  aluminum electrolytic capacitor from  $V_{AUD}$  to GND<sub>AUD</sub>,  $V_{12}$  to GND<sub>AUD</sub>, and  $V_{VID}$  to GND<sub>VID</sub>, SET = 100k $\Omega$  nominal,  $R_{LOAD} = 150\Omega$ ,  $T_A = 0^\circ C$  to  $+70^\circ C$ , unless otherwise noted. Typical values are at  $T_A = +25^\circ C$ .) (Note 1)

PARAMETER	SYMBOL	CONDITIONS	MIN	TYP	MAX	UNITS
<b>DIGITAL INTERFACE: SDA AND SCL (Note 5)</b>						
Low-Level Input Voltage	$V_{IL}$		0		0.8	V
High-Level Input Voltage	$V_{IH}$		2.6			V
Hysteresis of Schmitt Trigger Input				0.2		V
SDA Low-Level Output Voltage	$V_{OL}$	$I_{SINK} = 3mA$			0.4	V
		$I_{SINK} = 6mA$			0.6	
Output Fall Time for SDA Line		400pF bus load			250	ns
Spike Suppression				50		ns
Input Current			-10		+10	$\mu A$
Input Capacitance				5		pF
SCL Clock Frequency			0		400	kHz
Hold Time	$t_{HD,STA}$		0.6			$\mu s$
Low Period of SCL Clock	$t_{LOW}$		1.3			$\mu s$
High Period of SCL Clock	$t_{HIGH}$		0.6			$\mu s$
Setup Time for a Repeated Start Condition	$t_{SU,STA}$		0.6			$\mu s$
Data Hold Time	$t_{HD,DAT}$		0		0.9	$\mu s$
Data Setup Time	$t_{SU,DAT}$		100			ns
Setup Time for Stop Condition	$t_{SU,STO}$		0.6			$\mu s$
Bus Free Time Between a Stop and Start	$t_{BUF}$		1.3			$\mu s$
<b>OTHER DIGITAL PINS (Note 5)</b>						
DEV_ADDR Low Level					0.8	V
DEV_ADDR High Level			2.6			V
<b>SLOW SWITCHING SECTION (Note 5)</b>						
Input Low Level			0		2	V
Input Medium Level			4.5		7.0	V
Input High Level			9.5		$V_{12}$	V
Input Current				50	100	$\mu A$
Output Low Level		10k $\Omega$ to ground, internal TV, $11.4V < V_{12} < 12.6V$	0		1.5	V
Output Medium Level		10k $\Omega$ to ground, external 16/9, $11.4V < V_{12} < 12.6V$	5.0		6.5	V
Output High Level		10k $\Omega$ to ground, external 4/3, $11.4V < V_{12} < 12.6V$	10		$V_{12}$	V

# Audio/Video Switch for Dual SCART Connectors

## ELECTRICAL CHARACTERISTICS (continued)

( $V_{12} = 12V$ ,  $V_{VID} = V_{AUD} = 5V$ ,  $0.1\mu F$  X5R capacitor in parallel with a  $10\mu F$  aluminum electrolytic capacitor from  $V_{AUD}$  to  $GND_{AUD}$ ,  $V_{12}$  to  $GND_{AUD}$ , and  $V_{VID}$  to  $GND_{VID}$ ,  $SET = 100k\Omega$  nominal,  $R_{LOAD} = 150\Omega$ ,  $T_A = 0^\circ C$  to  $+70^\circ C$ , unless otherwise noted. Typical values are at  $T_A = +25^\circ C$ .) (Note 1)

PARAMETER	SYMBOL	CONDITIONS	MIN	TYP	MAX	UNIT
<b>FAST SWITCHING SECTION (Note 5)</b>						
Input Low Level			0		0.4	V
Input High Level			1		3	V
Input Current				1	10	$\mu A$
Output Low Level		$I_{SINK} = 0.5mA$	0	0.01	0.2	V
Output High Level		$I_{SOURCE} = 20mA$ , $V_{VID} - V_{OH}$		0.75	2	V
Fast Switching Output to RGB Skew		(Note 4)		30		ns
Fast Switching Output Rise Time		$150\Omega$ to ground		30		ns
Fast Switching Output Fall Time		$150\Omega$ to ground		30		ns

- Note 1:** All devices are 100% tested at  $T_A = +25^\circ C$ . All temperature limits are guaranteed by design.
- Note 2:** The settling time is measured from the 50% of the input swing to the 0.1% of the final value of the output.
- Note 3:** Maximum load capacitance is 200pF. All the listed parameters are measured at application's inputs, unless otherwise noted. See the *Typical Application Circuits*.
- Note 4:** Difference in propagation delays of fast-blanking signal and RGB signals. Measured from 50% input transition to 50% output transition. Signal levels to be determined.
- Note 5:** Guaranteed by design.

## Typical Operating Characteristics

( $V_{12} = 12V$ ,  $V_{VID} = V_{AUD} = 5V$ ,  $0.1\mu F$  X5R capacitor in parallel with a  $10\mu F$  aluminum electrolytic capacitor from  $V_{AUD}$  to  $GND_{AUD}$ ,  $V_{12}$  to  $GND_{AUD}$ ,  $V_{VID}$  to  $GND_{VID}$  no load,  $T_A = 0^\circ C$  to  $+70^\circ C$ , unless otherwise noted. Typical values are at  $T_A = +25^\circ C$ .)

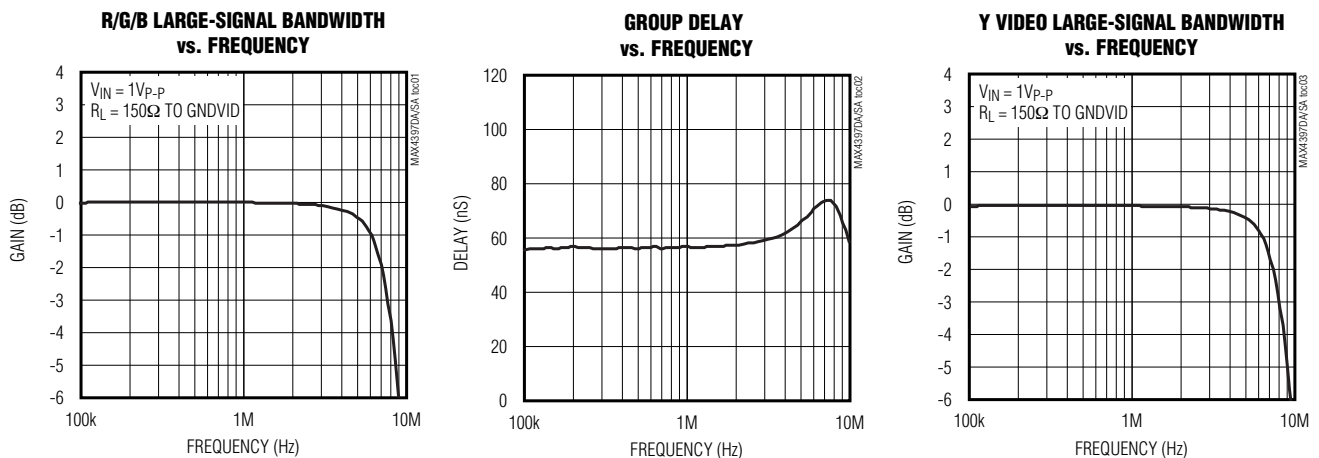

# Audio/Video Switch for Dual SCART Connectors

## Typical Operating Characteristics (continued)

( $V_{I2} = 12V$ ,  $V_{VID} = V_{AUD} = 5V$ ,  $0.1\mu F$  X5R capacitor in parallel with a  $10\mu F$  aluminum electrolytic capacitor from  $V_{AUD}$  to  $GND_{AUD}$ ,  $V_{I2}$  to  $GND_{AUD}$ ,  $V_{VID}$  to  $GND_{VID}$  no load,  $T_A = 0^\circ C$  to  $+70^\circ C$ , unless otherwise noted. Typical values are at  $T_A = +25^\circ C$ .)

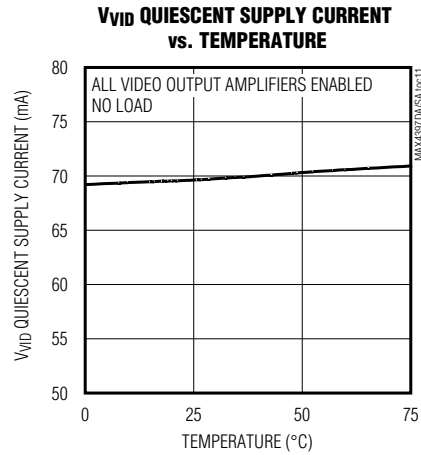
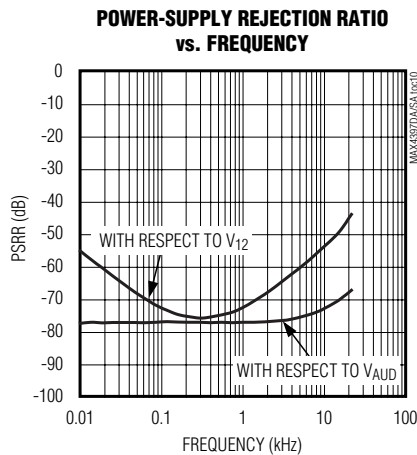
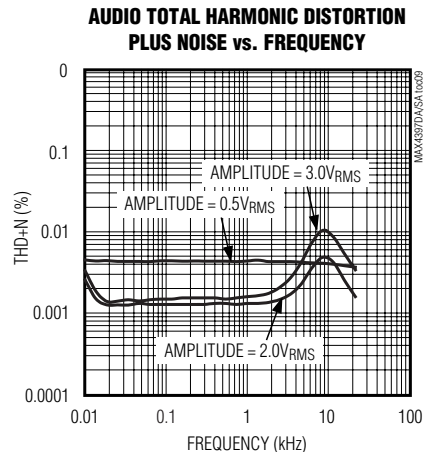
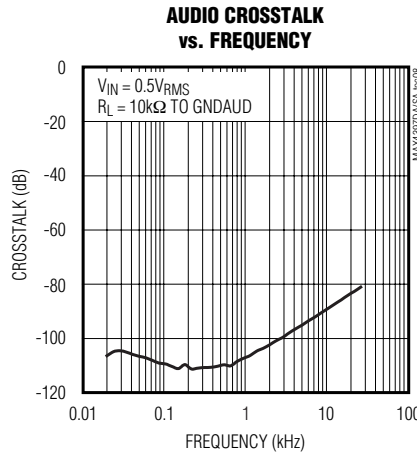
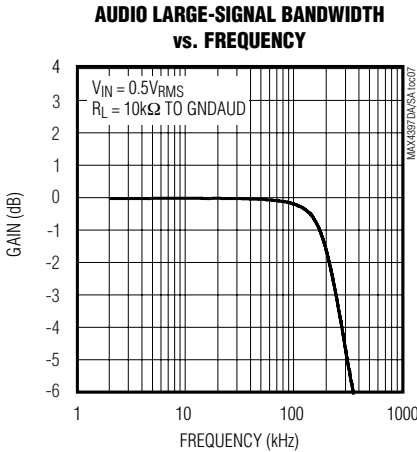
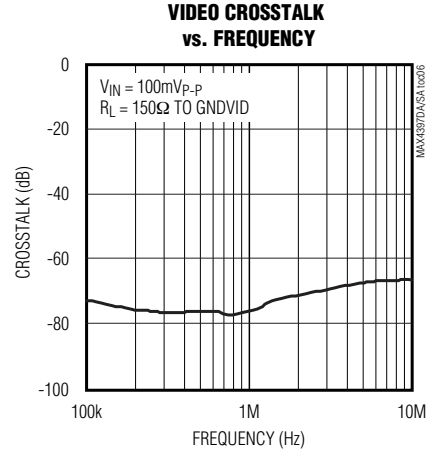
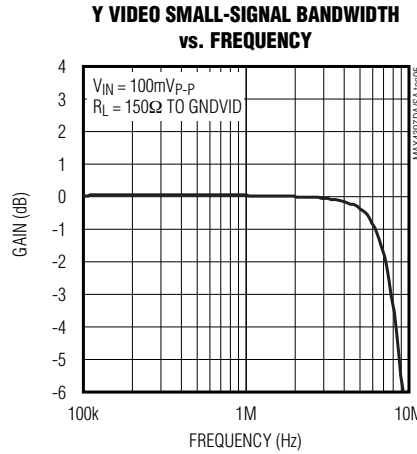
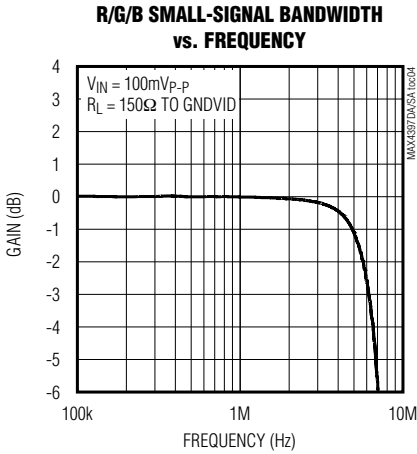

# Audio/Video Switch for Dual SCART Connectors

## Typical Operating Characteristics (continued)

( $V_{12} = 12V$ ,  $V_{VID} = V_{AUD} = 5V$ ,  $0.1\mu F$  X5R capacitor in parallel with a  $10\mu F$  aluminum electrolytic capacitor from  $V_{AUD}$  to  $GND_{AUD}$ ,  $V_{12}$  to  $GND_{AUD}$ ,  $V_{VID}$  to  $GND_{VID}$  no load,  $T_A = 0^\circ C$  to  $+70^\circ C$ , unless otherwise noted. Typical values are at  $T_A = +25^\circ C$ .)

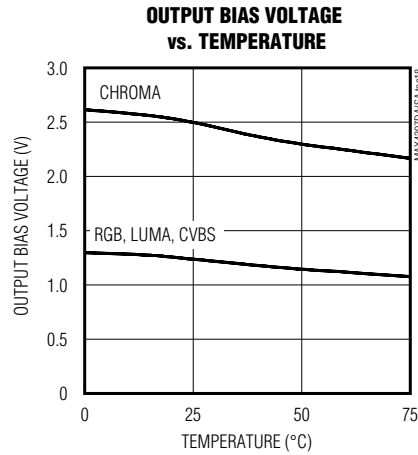
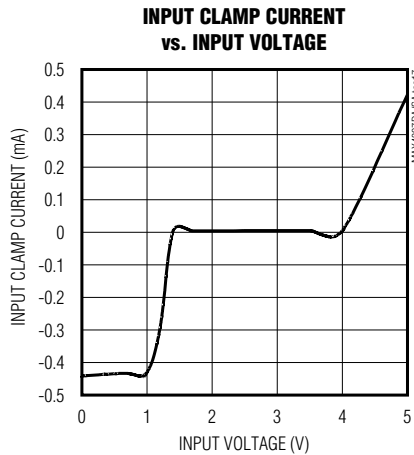
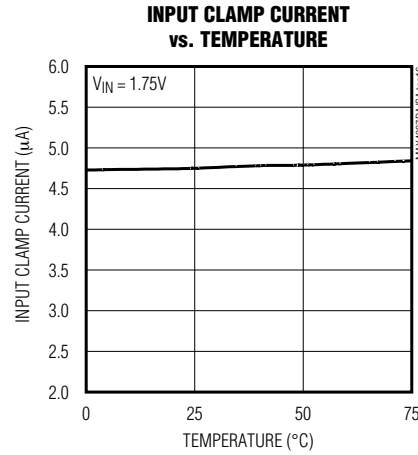
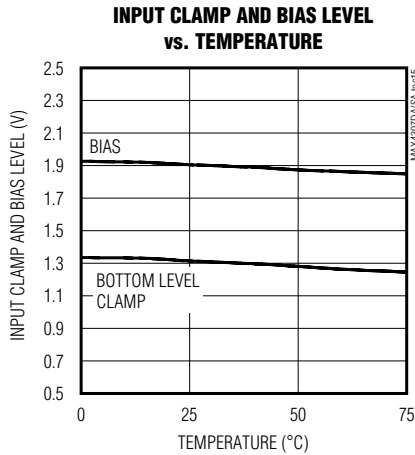
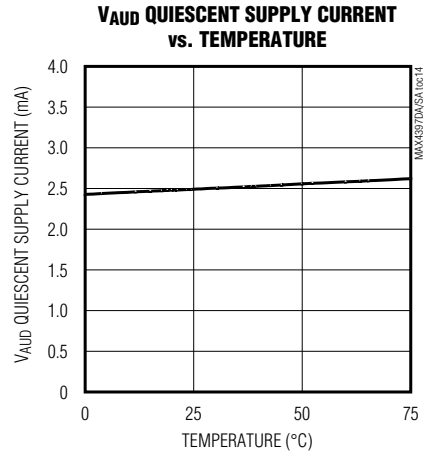
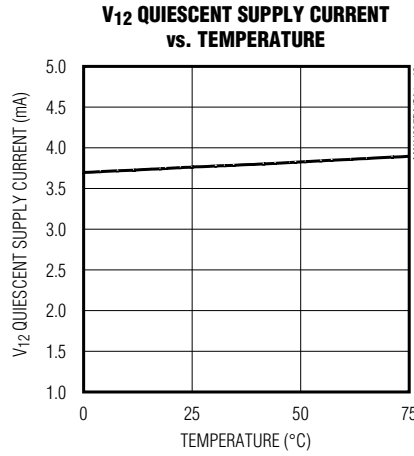
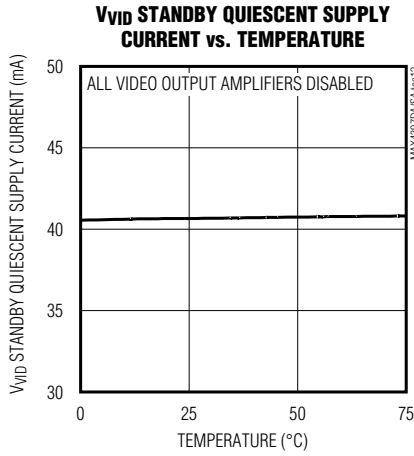

# Audio/Video Switch for Dual SCART Connectors

## Pin Description

**MAX4397DA/SA**

PIN		NAME	FUNCTION
MAX4397DA	MAX4397SA		
1	1	SDA	Bidirectional Data I/O. I <sup>2</sup> C-compatible, 2-wire interface data input/output. Output is open drain.
2	2	SCL	Serial-Clock Input. I <sup>2</sup> C-compatible, 2-wire clock interface.
3	3	DEV_ADDR	Device Address Set Input. Connect to GNDVID to set write and read addresses of 94h or 95h, respectively. Connect to V <sub>VID</sub> to set write and read address of 96h or 97h, respectively.
4	—	ENC_INL+	Digital Encoder Left-Channel Audio Positive Input
—	4	ENC_INL	Digital Encoder Left-Channel Audio Input
5	—	ENC_INL-	Digital Encoder Left-Channel Audio Negative Input
—	5, 7	N.C.	No Connection. Not internally connected.
6	—	ENC_INR+	Digital Encoder Right-Channel Audio Positive Input
—	6	ENC_INR	Digital Encoder Right-Channel Audio Input
7	—	ENC_INR-	Digital Encoder Right-Channel Audio Negative Input
8	8	VCR_INR	VCR SCART Right-Channel Audio Input
9	9	VCR_INL	VCR SCART Left-Channel Audio Input
10	10	TV_INR	TV SCART Right-Channel Audio Input
11	11	TV_INL	TV SCART Left-Channel Audio Input
12	12	GNDAUD	Audio Ground
13	13	AUD_BIAS	Audio Input Bias Voltage. Bypass AUD_BIAS with a 47μF capacitor and a 0.1μF capacitor to GNDAUD.
14	14	V <sub>AUD</sub>	Audio Supply. Connect to a +5V supply. Bypass with a 10μF aluminum electrolyte capacitor in parallel with a 0.47μF low-ESR ceramic capacitor to GNDAUD.
15	15	VCR_OUTR	VCR SCART Right-Channel Audio Output
16	16	VCR_OUTL	VCR SCART Left-Channel Audio Output
17	17	RF_MONO_OUT	RF Modulator Mono Audio Output
18	18	TV_OUTL	TV SCART Left-Channel Audio Output
19	19	TV_OUTR	TV SCART Right-Channel Audio Output
20	20	V <sub>12</sub>	+12V Supply. Bypass V <sub>12</sub> with a 10μF capacitor in parallel with a 0.1μF capacitor to ground.
21	21	TV_SS	TV SCART Bidirectional Slow-Switch Signal
22	22	VCR_SS	VCR SCART Bidirectional Slow-Switch Signal
23	23	SET	Filter Cutoff Frequency Set Input. Connect 100kΩ resistor from SET to ground.
24, 36	24, 36	V <sub>VID</sub>	Video and Digital Supply. Connect to a +5V supply. Bypass with a 0.01μF capacitor to GNDVID. V <sub>VID</sub> also serves as a digital supply for the I <sup>2</sup> C interface.
25	25	VCRIN_FS	VCR SCART Fast-Switching Input
26	26	ENCIN_FS	Digital Encoder Fast-Switching Input
27	27	TVOUT_FS	TV SCART Fast-Switching Output. This signal is used to switch the TV to its RGB inputs for on-screen display purposes.
28	28	GNDVID	Video Ground

# Audio/Video Switch for Dual SCART Connectors

## Pin Description (continued)

PIN		NAME	FUNCTION
MAX4397DA	MAX4397SA		
29	29	RF_CVBS_OUT	RF Modulator Composite Video Output. Internally biased at 1V.
30	30	TV_Y/CVBS_OUT	TV SCART Luma/Composite Video Output. Internally biased at 1V.
31	31	TV_R/C_OUT	TV SCART Red/Chroma Video Output. Internally biased at 1V for Red video signal and 2.2V for Chroma video signal.
32	32	TV_G_OUT	TV SCART Green Video Output. Internally biased at 1V.
33	33	TV_B_OUT	TV SCART Blue Video Output. Internally biased at 1V.
34	34	VCR_Y/CVBS_OUT	VCR SCART Luma/Composite Video Output. Internally biased at 1V.
35	35	VCR_R/C_OUT	VCR SCART Red/Chroma Video Output. Internally biased at 1V for Red video signals and 2.2V for Chroma video signal.
37	37	TV_R/C_IN	TV SCART Red/Chroma Video Input. Internally biased at 1.2V for Red video signals, or 1.9V for Chroma video signals.
38	38	TV_Y/CVBS_IN	TV SCART Luma/Composite Video Input. Internally biased at 1.2V.
39	39	VCR_Y/CVBS_IN	VCR SCART Luma/Composite Video Input. Internally biased at 1.2V.
40	40	VCR_R/C_IN	VCR SCART Red/Chroma Video Input. Internally biased at 1.2V for Red video signals and 1.9V for Chroma video signals.
41	41	VCR_G_IN	VCR SCART Green Video Input. Internally biased at 1.2V.
42	42	VCR_B_IN	VCR SCART Blue Video Input. Internally biased at 1.2V.
43	43	ENC_Y/CVBS_IN	Digital Encoder Luma/Composite Video Input. Internally biased at 1.2V.
44	44	ENC_R/C_IN	Digital Encoder Red/Chroma Video Input. Internally biased at 1.2V for Red video signals, or 1.9V for Chroma video signals.
45	45	ENC_G_IN	Digital Encoder Green Video Input. Internally biased at 1.2V.
46	46	ENC_B_IN	Digital Encoder Blue Video Input. Internally biased at 1.2V.
47	47	ENC_Y_IN	Digital Encoder Luma Video Input. Internally biased at 1.2V.
48	48	ENC_C_IN	Digital Encoder Chroma Video Input. Internally biased at 1.9V.
EP	EP	GNDAUD	Exposed Paddle. Solder to the circuit board ground (GNDAUD) for proper thermal and electrical performance.

### Detailed Description

The MAX4397DA/SA are switch matrices that route audio and video signals between different ports using the I<sup>2</sup>C interface. The ports consist of the MPEG decoder output, and two SCART connectors for the TV and VCR. Per EN50049 and IEC 933, the encoder can only input a signal to the SCART connector, while TV and VCR SCART connectors are bidirectional.

The MAX4397DA/SA circuitry consists of four major sections: the video section, the audio section, the slow- and fast-switching section, and the digital interface.

The video section consists of clamp and bias circuitry, input buffers, reconstruction filters, a switch matrix, a Y/C mixer, and output buffers. All video inputs are AC-coupled through a 0.1μF capacitor to set an acceptable DC

level using clamp or bias networks. The bidirectional Red/Chroma outputs can be connected to ground using I<sup>2</sup>C control to make them terminations when Red/Chroma is an input (see the *Video Inputs* section).

The audio section features an input buffer, a switching matrix, volume- or gain-control circuitry, and output drivers. The audio inputs are AC-coupled through a 0.1μF capacitor. Only the audio encoder inputs of the MAX4397DA are different from the MAX4397SA. The MAX4397SA has a single-ended audio encoder input while the audio encoder input for the MAX4397DA is differential. The TV output audio path has volume control from -56dB to +6dB in 2dB steps, while the VCR output audio path has volume control from -6dB to +6dB in 6dB steps. The MAX4397DA/SA can be configured to switch inputs during a zero-crossing function to reduce clicks.

# Audio/Video Switch for Dual SCART Connectors

The slow-switching feature allows for bidirectional, tri-level, slow-switching input and output signals at pin VCR\_SS and TV\_SS, respectively. The slow-switching signals from the VCR set the aspect ratio or video source of the TV screen. See the *Slow Switching* section.

Fast switching consists of two inputs from the encoder and VCR, and one output to the TV to insert an on-screen display (OSD). Fast switching is used to route video signals from the VCR or from the encoder to the TV. In addition, the fast-switching output can be configured to a high or low voltage. Fast switching is controlled through the I<sup>2</sup>C interface.

The digital block contains the 2-wire interface circuitry, control, and status registers. The MAX4397DA/SA can be configured through an I<sup>2</sup>C-compatible interface. DEV\_ADDR sets the I<sup>2</sup>C-compatible address.

## SCART Video Switching

The MAX4397DA/SA switch video signals between an MPEG decoder, TV SCART, and VCR SCART. The video switch includes reconstruction filters, multiplexed video amplifiers, and a Y/C mixer driver for an RF modulator. See Figure 1 for the functional diagram of the video section. While the SCART connector supports RGB, S-video, and Composite video formats, RGB, and S-video typically share a bidirectional set of SCART connector pins.

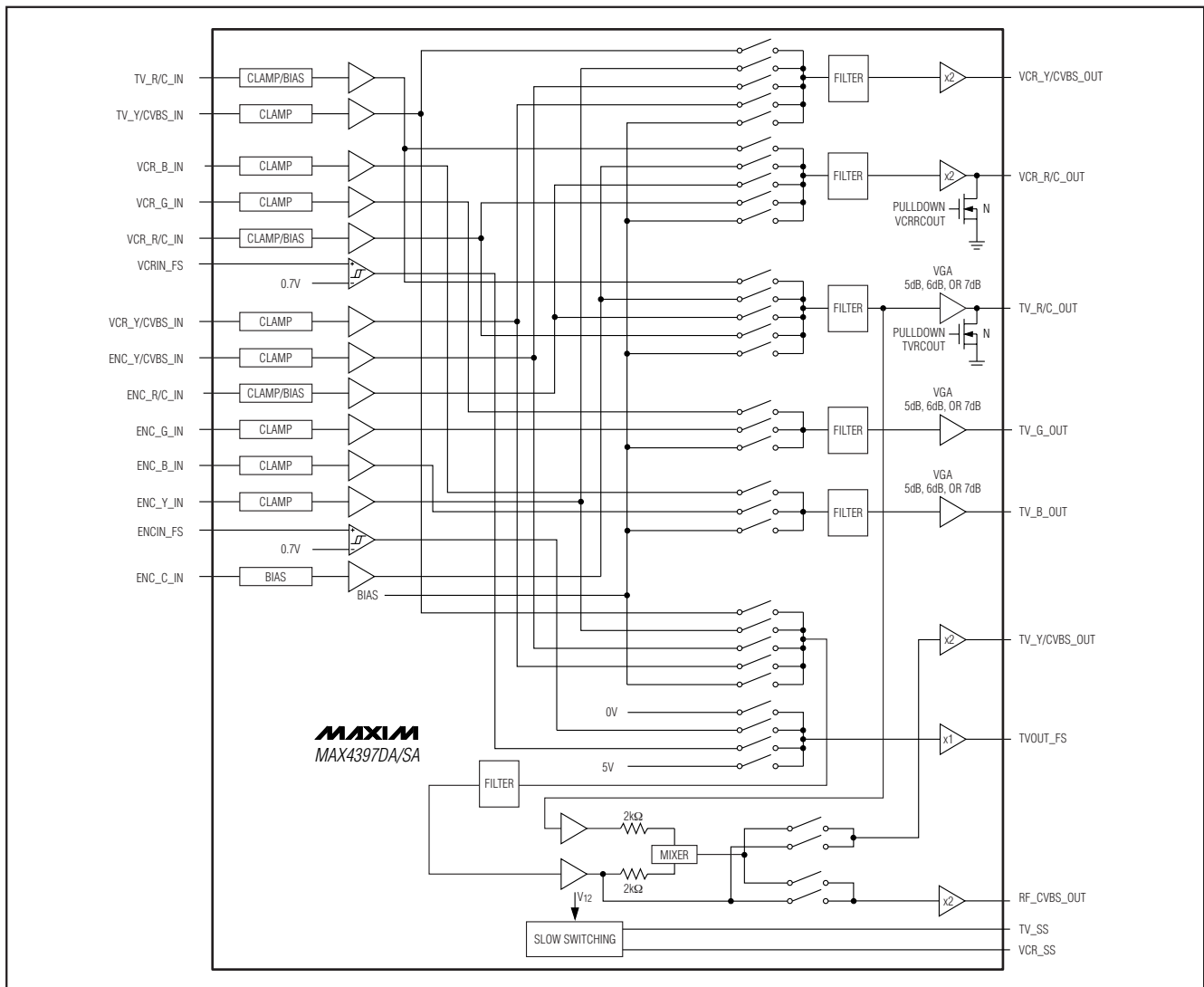

Figure 1. MAX4397DA/SA Video Section Functional Diagram

# Audio/Video Switch for Dual SCART Connectors

## Video Inputs

All video inputs are AC-coupled with an external 0.1µF capacitor. Either a clamp or bias circuit sets the DC input level of the video signals. The clamp circuit positions the sync tip of the Composite (CVBS), the Component RGB, or the S-Video Luma signal. If the signal does not have a sync tip, then the clamp positions the minimum of the signal at the clamp voltage. The bias circuitry is used to position the S-video Chroma signal at midlevel of the Luma (Y) signal. On the video inputs that can receive either a Chroma or a Red video signal, the bias or clamp circuit is selected through I<sup>2</sup>C. See Tables 3–12 for loading register details.

The MPEG decoder and VCR uses the RGB format and fast switching to insert an on-screen display (OSD), usually text, onto the TV. The MAX4397DA/SA support RGB as an input from either the VCR or the MPEG decoder and as an output only to the TV. The Red video signal of the RGB format and the Chroma video signal of the S-VHS format share the same SCART connector pin. Therefore, RGB and S-video signals cannot be present at the same time. Loop-through is possible with a Composite video signal but not with RGB signals because the RGB SCART pins are used for both input and output.

In SCART, there is the possibility of a bidirectional use of the Red/Chroma pin. When using the Red/Chroma

pin as an input port, terminate the Red/Chroma output with a 75Ω resistor to ground. Thus, a ground state is provided by an active pull-down to GNDVID on the Red/Chroma output to support the bidirectional Chroma or Red I/O, turning the output source resistors into terminations (see Figure 2). The active pull-down also provides the “Mute Output” function and disables the deselected video outputs. The “Mute Output” state is the default power-on state for video.

For high-quality home video, the MPEG decoder, VCR, and TV use the S-video format. The MAX4397DA/SA support S-video signals as an input from the VCR, the MPEG decoder, and the TV, and also as a separately switchable output to the TV and VCR. Because S-video support was not included in the original specifications of the SCART connector, the Luma (Y) signal of S-video and the CVBS signal share the same SCART connector pins. If S-video is present, then a Composite signal must be created from the Y and C signals to drive the RF\_CVBS\_OUT pin. For S-video, loop-through is not possible since the Chroma SCART port is used for both input and output.

The MAX4397DA/SA support Composite video (CVBS) format, with inputs from the VCR, MPEG decoder, and TV. Full loop-through is possible to the TV and VCR only since the MPEG decoder SCART connector has separate input and output pins for the CVBS format.

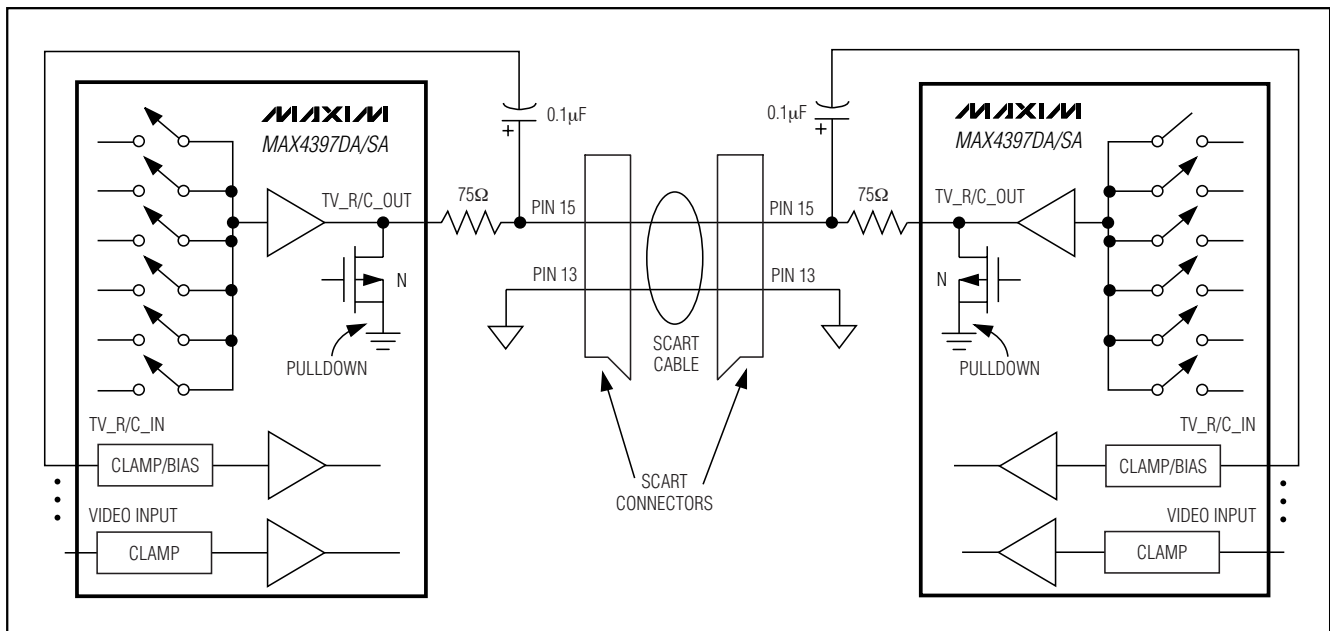

Figure 2. Bidirectional SCART Pins

# Audio/Video Switch for Dual SCART Connectors

## Video Outputs

The DC level at the video outputs is controlled so that coupling capacitors are not required, and all of the video outputs are capable of driving a DC-coupled, 150Ω, back-terminated coax load with respect to ground.

In a typical television input circuit (see Figure 3), the video output driver on the SCART chip only needs to source current. Users should note that, while the SCART specification states 75Ω impedance, in practice, typical SCART chip implementations assume 75Ω input resistance to ground (and source current from the video output stage).

Since some televisions and VCRs use the horizontal sync height for automatic gain control, the MAX4397DA/SA accurately reproduce the sync height to within ±2%.

## Slow Switching

The MAX4397DA/SA support the IEC 933-1, Amendment 1, tri-level slow switching that selects the aspect ratio for the display (TV). Under I<sup>2</sup>C-compatible control, the MAX4397DA/SA set the slow-switching output voltage level. Table 1 shows the valid input levels of the slow-switching signal and the corresponding operating modes of the display device.

Two bidirectional ports are available for slow-switching signals for the TV and VCR. The slow-switching input status is continuously read and stored in the register 0Eh. The slow-switching outputs can be set to a logic level or high impedance by writing to registers 07h and 09h. See Tables 8 and 10 for details.

## Fast Switching

The VCR or MPEG decoder outputs a fast-switching signal to the display device or TV to insert an on-screen display (OSD). The fast-switching signal can also be

set to a constant high or low output signal through the I<sup>2</sup>C interface. The fast-switching output can be set through writing to register 07h.

## Y/C Mixer

The MAX4397DA/SA include an on-chip mixer to produce Composite video (CVBS) when S-video (Y and C) is present. The Composite video drives the RF\_CVBS\_OUT output pin. The circuit sums Y and C signals to obtain the CVBS component. A +6dB output buffer drives RF\_CVBS\_OUT.

## Video Reconstruction Filter

The encoder DAC outputs need to be lowpass-filtered to reject the out-of-band noise. The MAX4397DA/SA integrate the reconstruction filter. The filter is fourth order, which is composed of two Sallen-Key biquad in cascade, implementing a Butterworth-type transfer function. The internal reconstruction filters feature a 5.5MHz cutoff frequency and -30dB minimum attenuation at 27MHz. Note that the SET pin is used to set the accuracy of the filter cutoff frequency. Connect a 100kΩ resistor from SET to ground.

## SCART Audio Switching

### Audio Inputs

All audio inputs for the MAX4397SA are single-ended and AC-coupled. The MAX4397DA audio inputs are single-ended and AC-coupled except for the audio encoder input, which is differential DC-coupled.

The audio block has three stereo audio inputs from the TV, the VCR, and the MPEG decoder SCART. Each input has a 100kΩ resistor connected to an internally generated voltage equal to 0.23 × V<sub>12</sub>, except for the encoder input of the MAX4397DA, where the DC bias is fixed externally.

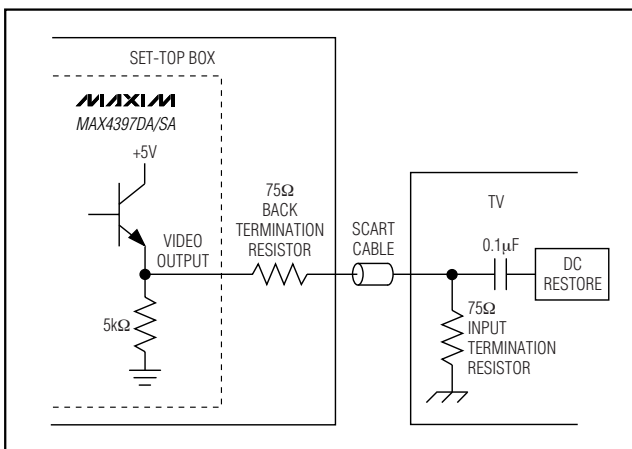

Figure 3. Typical TV Input Circuit

Table 1. Slow-Switching Modes

SLOW-SWITCHING SIGNAL VOLTAGE (V)	MODE
0 to 2	Display device uses an internal source such as a built-in tuner to provide a video signal
4.5 to 7.0	Display device uses a video signal from the SCART connector and sets the display to a 16:9 aspect ratio
9.5 to 12.6	Display device uses a signal from the SCART connector and sets the display to a 4:3 aspect ratio

# Audio/Video Switch for Dual SCART Connectors

## Audio Outputs

Both right and left channels have a stereo output for the TV and VCR SCART. The monaural output, which is a mix of the TV right and left channels, drives the RF modulator, RF\_MONO\_OUT. The monaural mixer, a resistor summer, attenuates the amplitude of each of the two signals by 6dB. A 12.54dB gain block follows the monaural mixer. If the left and right audio channels

were completely uncorrelated, then a 9.54dB gain block is used. See Figures 4 and 5 for the functional diagram of the audio section.

## Clickless Switching

The TV channel incorporates a zero-crossing detect (ZCD) circuit that minimizes click noise due to abrupt signal level changes that occur when switching between audio signals at an arbitrary moment.

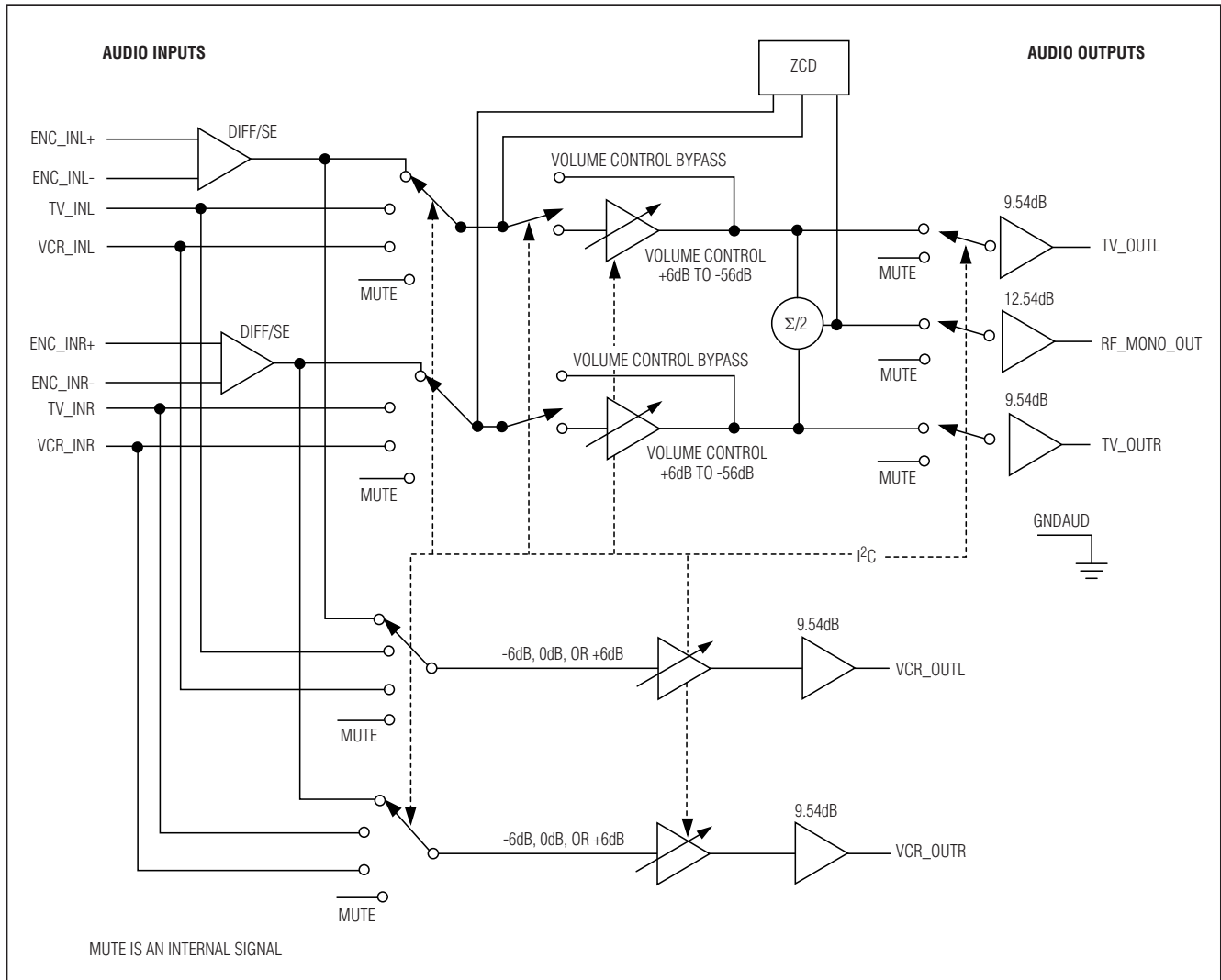

Figure 4. MAX4397DA Audio Section Functional Diagram

# Audio/Video Switch for Dual SCART Connectors

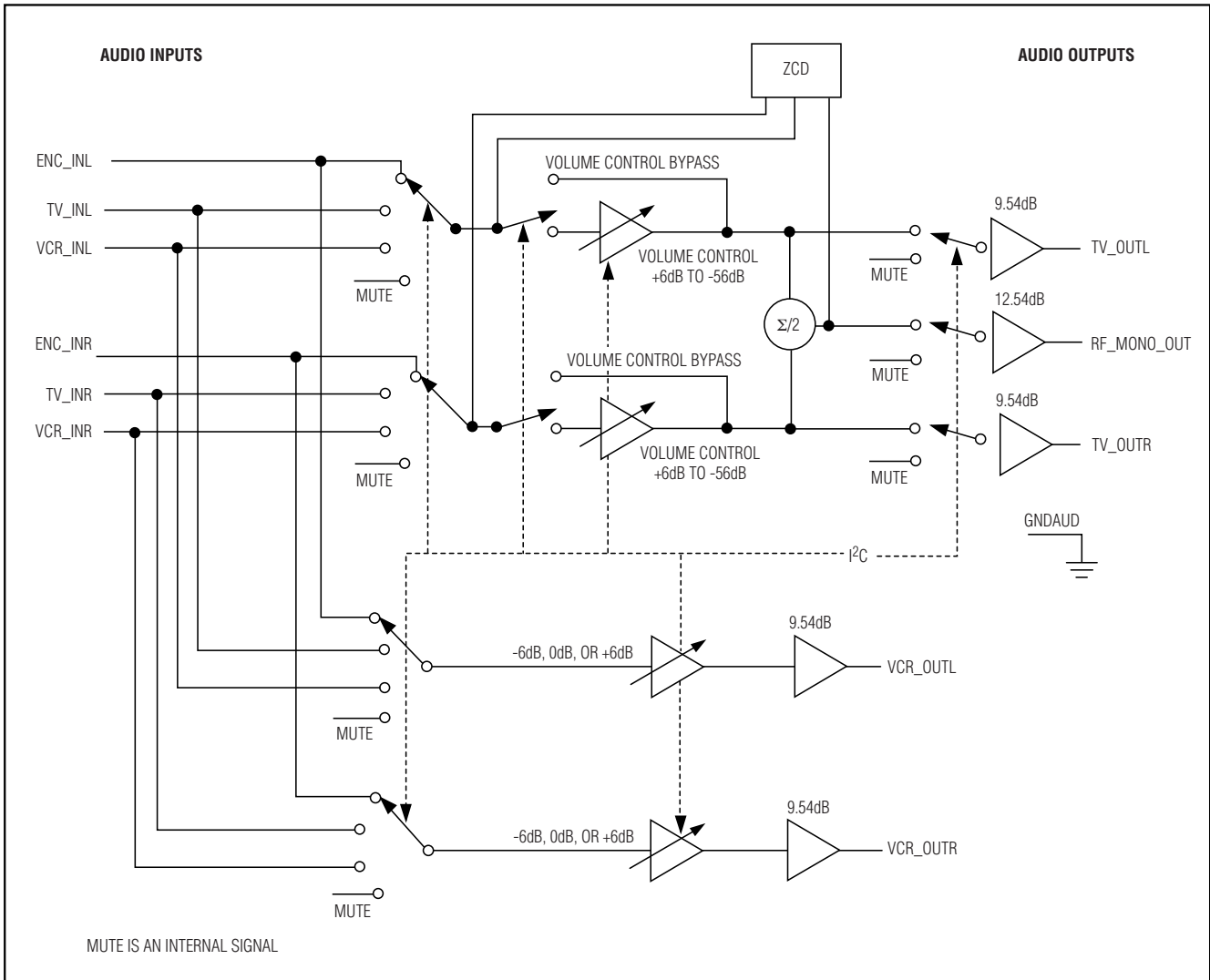

Figure 5. MAX4397SA Audio Section Features Singled-Ended Encoder Input

To implement the zero-crossing function when switching audio signals, set the ZCD bit by loading register 00h through the I<sup>2</sup>C-compatible interface (if the ZCD bit is not already set). Then set the mute bit low by loading register 00h. Next, wait for a sufficient period of time for the audio signal to cross zero. This period is a function of the audio signal path's low-frequency 3dB corner ( $f_{L3dB}$ ). Thus, if  $f_{L3dB} = 1\text{kHz}$ , the time period to wait for a zero-crossing detect is  $1/2\text{kHz}$  or 0.5ms.

Next, set the appropriate TV switches using register 01h. Finally, clear the mute bit (while leaving the ZCD bit high) using register 00h. The MAX4397DA/SA switches the signal out of mute at the next zero crossing.

To implement the zero-cross function for TV volume changes, or for TV and phono volume bypass switching, simply ensure the ZCD bit in register 00h is set.

# Audio/Video Switch for Dual SCART Connectors

### Volume Control

The TV channel volume control ranges from -56dB to +6dB in 2dB steps. The VCR volume control settings are programmable for -6dB, 0dB, and +6dB. These gain levels are referenced to the application inputs, where some dividers are present. With the ZCD bit set, the TV volume control switches only at zero-crossings, thus minimizing click noise. The TV outputs can bypass the volume control. Likewise, the monaural output signal can be processed by the TV volume control or it can bypass the volume control.

### Digital Section

#### Serial Interface

The MAX4397DA/SA use a simple 2-wire serial interface requiring only two standard microprocessor port I/O lines. The fast-mode I<sup>2</sup>C-compatible serial interface allows communication at data rates up to 400kbps or 400kHz. Figure 6 shows the timing diagram of the signals on the 2-wire interface.

The two bus lines (SDA and SCL) must be at logic-high when the bus is not in use. The MAX4397DA/SA are slave devices and must be controlled by a master device. Pullup resistors from the bus lines to the supply are required when push-pull circuitry is not driving the lines.

The logic level on the SDA line can only change when the SCL line is low. The start and stop conditions occur when SDA toggles low/high while the SCL line is high (see Figure 6). Data on SDA must be stable for the duration of the setup time ( $t_{SU,DAT}$ ) before SCL goes high. Data on SDA is sampled when SCL toggles high with data on SDA stable for the duration of the hold time ( $t_{HD,DAT}$ ). Note that data is transmitted in an 8-bit byte. A total of nine clock cycles are required to transfer a byte to the MAX4397DA/SA. The device acknowledges the successful receipt of the byte by pulling the SDA line low during the 9th clock cycle.

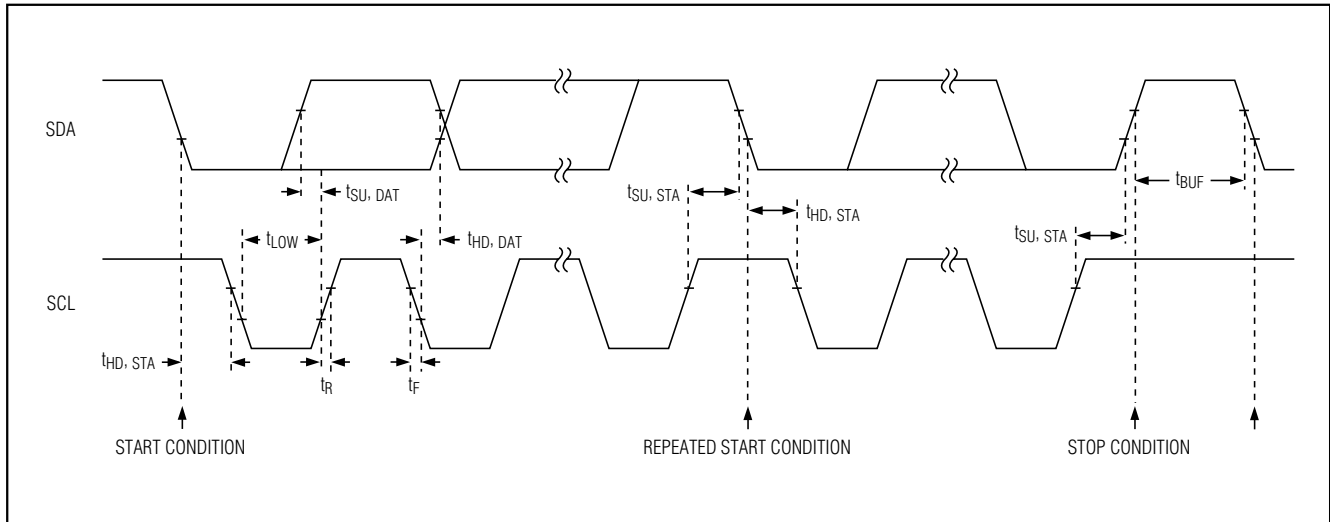

Figure 6. SDA and SCL Signal Timing Diagram

# Audio/Video Switch for Dual SCART Connectors

## Data Format of the I<sup>2</sup>C Interface

### Write Mode

S	Slave Address (Write address)	A	Register Address	A	Data	A	P
---	-------------------------------	---	------------------	---	------	---	---

### Read Mode

S	Slave Address (Write address)	A	Register Address	A	Sr	Slave Address (Read address)	A	Data	NA	P
---	-------------------------------	---	------------------	---	----	------------------------------	---	------	----	---

S = Start Condition, A = Acknowledge, NA = Not Acknowledge, Sr = Repeat Start Condition, P = Stop Condition

### I<sup>2</sup>C Compatibility

The MAX4397DA/SA are compatible with existing I<sup>2</sup>C systems. SCL and SDA are high-impedance inputs. SDA has an open drain that pulls the bus line to a logic-low during the 9th clock pulse. Figure 7 shows a typical I<sup>2</sup>C interface application. The communication protocol supports the standard I<sup>2</sup>C 8-bit communications. The MAX4397DA/SA address is compatible with the 7-bit I<sup>2</sup>C addressing protocol only; 10-bit format is not supported.

### Digital Inputs and Interface Logic

The I<sup>2</sup>C-compatible, 2-wire interface has logic levels defined as V<sub>IL</sub> = 0.8V and V<sub>IH</sub> = 2.0V. All of the inputs include Schmitt-trigger buffers to accept low-transition interfaces. The digital inputs are compatible with 3V CMOS logic levels.

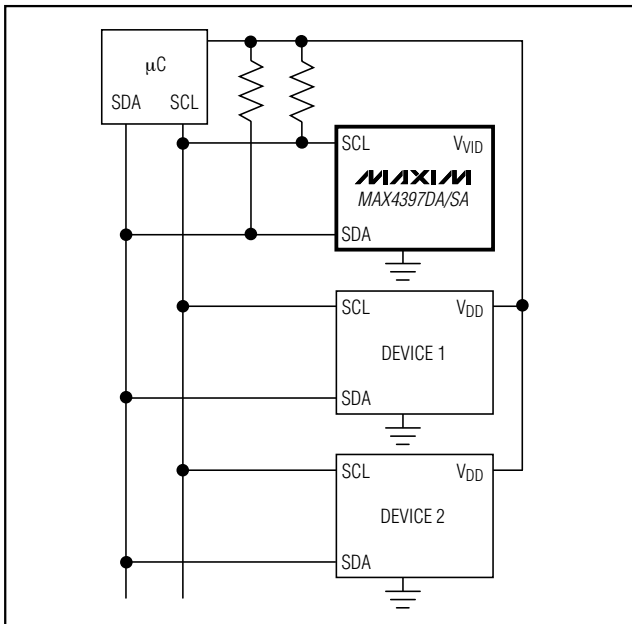

Figure 7. Typical I<sup>2</sup>C Interface Application

### Programming

Connect DEV\_ADDR to ground to set the MAX4397DA/SA write and read address as shown in Table 2.

Table 2. Slave Address Programming

ADDRESS PIN STATE	WRITE ADDRESS	READ ADDRESS
V <sub>VID</sub>	96h	97h
GND <sub>VID</sub>	94h	95h

### Data Register Writing and Reading

Program the SCART video and audio switches by writing to registers 00h through 0Dh. Registers 00h through 0Eh can also be read, allowing readback of data after programming and facilitating system debugging. The status register is read-only and can be read from address 0Eh. See Tables 3–12 for register programming information.

### Applications Information

#### Hot Plug of SCART Connectors

The MAX4397DA/SA feature high-ESD protection on all SCART inputs and outputs, and requires no external transient-voltage suppressor (TVS) devices to protect against floating chassis discharge. Some set-top boxes have a floating chassis problem in which the chassis is not connected to earth ground. As a result, the chassis can charge up to 500V. When a SCART cable is connected to the SCART connector, the charged chassis can discharge through a signal pin. The equivalent circuit is a 2200pF capacitor charged to 311V connected through less than 0.1Ω to a signal pin. The MAX4397DA/SA are soldered on the PCB when it experiences such a discharge. Therefore, the current spike flows through the ESD protection diodes and is absorbed by the supply bypass capacitors, which have high capacitance and low ESR.

To better protect the MAX4397DA/SA against excess voltages during the cable discharge condition, place an additional 75Ω resistor in series with all inputs and outputs to the SCART connector. For harsh environments where ±15kV protection is needed, the MAX4385E and MAX4386E single and quad high-speed op amps feature the industry's first integrated ±15kV ESD protection on video inputs and outputs.

# Audio/Video Switch for Dual SCART Connectors

## Power Supplies and Bypassing

The MAX4397DA/SA feature single 5V and 12V supply operation and requires no negative supply. The +12V supply V<sub>12</sub> is for the SCART switching function. For pin V<sub>12</sub>, place all bypass capacitors as close as possible with a 10 $\mu$ F capacitor in parallel with a 0.1 $\mu$ F ceramic capacitor. Connect all V<sub>AUD</sub> pins together to +5V and bypass with a 10 $\mu$ F electrolytic capacitor in parallel with a 0.47 $\mu$ F low-ESR ceramic capacitor to audio ground. Bypass V<sub>AUD</sub> pins with a 0.1 $\mu$ F capacitor to audio ground. Bypass AUD\_BIAS to audio ground with a 10 $\mu$ F electrolytic in parallel with a 0.1 $\mu$ F ceramic capacitor.

Bypass V<sub>DIG</sub> with a 0.1 $\mu$ F ceramic capacitor to digital ground. Bypass each V<sub>VID</sub> to video ground with a 0.1 $\mu$ F ceramic capacitor. Connect V<sub>VID</sub> in series with a 200nH ferrite bead to the +5V supply.

## Layout and Grounding

For optimal performance, use controlled-impedance traces for video signal paths and place input termination resistors and output back-termination resistors close to the MAX4397DA/SA. Avoid routing video traces parallel to high-speed data lines.

The MAX4397DA/SA provide separate ground connections for video, audio, and digital supplies. For best performance, use separate ground planes for each of the ground returns and connect all three ground planes together at a single point. Refer to the MAX4397DA/SA evaluation kit for a proven circuit board layout example.

**Table 3. Data Format for Write Mode**

REGISTER ADDRESS (HEXADECIMAL)	BIT 7	BIT 6	BIT 5	BIT 4	BIT 3	BIT 2	BIT 1	BIT 0
00h	TV volume bypass	ZCD	TV volume control					TV audio output mute
01h	VCR volume control		Not used	Not used	VCR audio selection		TV audio selection	
02h	Not used							
03h	Not used							
04h	Not used							
05h	Not used							
06h	TV_R/C_IN clamp	RGB gain		TV G and B video switch		TV video switch		
07h	Not used	RF_CVBS_OUT switch	TV_Y/CVBS_OUT switch	TV fast blank (fast switching)		TV_R/C_OUT ground	Set function TV	
08h	VCR_R/C_IN clamp	Not used	Not used	Not used	ENC_R/C_IN clamp	VCR video switch		
09h	Not used	Not used	Not used	Not used	Not used	VCR_R/C_OUT ground	Set function VCR	
0Ah	Not used							
0Bh	Not used							
0Ch	Not used							
0Dh	VCR_Y/CVBS_OUT enable	VCR_R/C_OUT enable	TV_R/C_OUT enable	TV_G_OUT enable	TV_B_OUT enable	TV_Y/CVBS_OUT enable	TVOUT_FS enable	RF_CVBS_OUT enable

# Audio/Video Switch for Dual SCART Connectors

**Table 4. Data Format for Read Mode**

REGISTER ADDRESS (HEXADECIMAL)	BIT 7	BIT 6	BIT 5	BIT 4	BIT 3	BIT 2	BIT 1	BIT 0
0Eh	Thermal SHDN	Power-on reset	Not used		VCR slow switch input		TV slow switch input	

**Table 5. Register 00h: TV Audio Control**

DESCRIPTION	BIT								COMMENTS
	7	6	5	4	3	2	1	0	
TV Audio Mute								0	Off
								1	On (power-on default)
TV Volume Control			0	0	0	0	0		+6dB gain
			0	0	0	0	1		+4dB gain
			0	0	0	1	0		+2dB gain
			0	0	0	1	1		0dB gain (power-on default)
			0	0	1	0	0		-2dB gain
			0	0	1	0	1		-4dB gain
			1	1	1	1	0		-54dB gain
TV Zero-Crossing Detector		0							Off
		1							On (power-on default)
TV Volume Bypass	0								TV audio passes through volume control (power-on default)
	1								TV audio bypasses volume control

**Table 6. Register 01h: TV/VCR Audio Control**

DESCRIPTION	BIT								COMMENTS
	7	6	5	4	3	2	1	0	
Input Source for TV Audio							0	0	Encoder audio
							0	1	VCR audio
							1	0	TV audio
							1	1	Mute (power-on default)
Input Source for VCR Audio					0	0			Encoder audio
					0	1			VCR audio
					1	0			TV audio
					1	1			Mute (power-on default)
VCR Volume Control	0	0							0dB gain (power-on default)
	0	1							+6dB gain
	1	0							-6dB gain
	1	1							0dB gain

## Audio/Video Switch for Dual SCART Connectors

Table 7. Register 06h: TV Video Input Control

DESCRIPTION	BIT								COMMENTS	
	7	6	5	4	3	2	1	0		
Input Sources for TV Video									<b>TV_Y/CVBS_OUT</b>	<b>TV_R/C_OUT</b>
						0	0	0	ENC_Y/CVBS_IN	ENC_R/C_IN
						0	0	1	ENC_Y_IN	ENC_C_IN
						0	1	0	VCR_Y/CVBS_IN	VCR_R/C_IN
						0	1	1	TV_Y/CVBS_IN	TV_R/C_IN
						1	0	0	Not used	Not used
						1	0	1	Mute	Mute
						1	1	0	Mute	Mute
Input Sources for TV_G_OUT and TV_B_OUT									<b>TV_G_OUT</b>	<b>TV_B_OUT</b>
				0	0				ENC_G_IN	ENC_B_IN
				0	1				VCR_G_IN	VCR_B_IN
				1	0				Mute	Mute
RGB Gain									Mute (power-on default)	Mute (power-on default)
		0	0						6dB (power-on default)	
		0	1						7dB	
		1	0						5dB	
TV_R/C_IN Clamp/Bias									5dB	
	0								DC restore clamp active at input (power-on default)	
	1								Chrominance bias applied at input	

# Audio/Video Switch for Dual SCART Connectors

**Table 8. Register 07h: TV Video Output Control**

DESCRIPTION	BIT								COMMENTS
	7	6	5	4	3	2	1	0	
Set TV Function Switching							0	0	Low (< 2V), internal source (power-on default)
							0	1	Medium (4.5V to 7V), external SCART source with 16:9 aspect ratio
							1	0	High impedance
							1	1	High (> 9.5V), external SCART source with 4:3 aspect ratio
TV_R/C_OUT Ground						0			Normal operation, pulldown on TV_R/C_OUT is off (power-on default)
						1			Ground, pulldown on TV_R/C_OUT is on, the output amplifier driving TV_R/C_OUT is turned off
Fast Blank (Fast Switching)				0	0				0V (power-on default)
				0	1				Same level as ENC_FB_IN
				1	0				Same level as VCR_FB_IN
				1	1				V <sub>VID</sub>
TV_Y/CVBS_OUT Switch			0						Composite video from the Y/C mixer is output
			1						The TV_Y/CVBS_OUT signal selected in register 06h is output (power-on default)
RF_CVBS_OUT Switch		0							Composite video from the Y/C mixer is output (power-on default)
		1							The TV_Y/CVBS_OUT signal selected in register 06h is output

**Table 9. Register 08h: VCR Video Input Control**

DESCRIPTION	BIT								COMMENTS	
	7	6	5	4	3	2	1	0	VCR_Y/CVBS_OUT	VCR_R/C_OUT
Input Sources for VCR Video						0	0	0	ENC_Y/CVBS_IN	ENC_R/C_IN
						0	0	1	ENC_Y_IN	ENC_C_IN
						0	1	0	VCR_Y/CVBS_IN	VCR_R/C_IN
						0	1	1	TV_Y/CVBS_IN	TV_R/C_IN
						1	0	0	Not used	Not used
						1	0	1	Mute	Mute
						1	1	0	Mute	Mute
						1	1	1	Mute (power-on default)	Mute (power-on default)
VCR_R/C_IN Clamp/Bias	0								DC restore clamp active at input (power-on default)	
	1								Chrominance bias applied at input	
ENC_R/C_IN Clamp/Bias					0				DC restore clamp active at input (power-on default)	
					1				Chrominance bias applied at input	

## Audio/Video Switch for Dual SCART Connectors

Table 10. Register 09h: VCR Video Output Control

DESCRIPTION	BIT								COMMENTS
	7	6	5	4	3	2	1	0	
Set VCR Function Switching							0	0	Low (< 2V), internal source (power-on default)
							0	1	Medium (4.5V to 7V), external SCART source with 16:9 aspect ratio
							1	0	High impedance
							1	1	High (> 9.5V), external SCART source with 4:3 aspect ratio
VCR_R/C_OUT ground						0			Normal operation, pulldown on VCR_R/C_OUT is off (power-on default)
						1			Ground, pulldown on VCR_R/C_OUT is on, the output amplifier driving VCR_R/C_OUT is turned off

Table 11. Register 0Dh: Output Enable

DESCRIPTION	BIT								COMMENTS
	7	6	5	4	3	2	1	0	
RF_CVBS_OUT								0	Off (power-on default)
								1	On
TVOUT_FS							0		Off (power-on default)
							1		On
TV_Y/CVBS_OUT						0			Off (power-on default)
						1			On
TV_B_OUT					0				Off (power-on default)
					1				On
TV_G_OUT				0					Off (power-on default)
				1					On
TV_R/C_OUT			0						Off (power-on default)
			1						On
VCR_R/C_OUT		0							Off (power-on default)
		1							On
VCR_Y/CVBS_OUT	0								Off (power-on default)
	1								On

## Audio/Video Switch for Dual SCART Connectors

Table 12. Register 0Eh Status

DESCRIPTION	BIT								COMMENTS
	7	6	5	4	3	2	1	0	
TV Slow Switch Input							0	0	0 to 2V, internal source
							0	1	4.5V to 7V, external source with 16:9 aspect ratio
							1	0	Not used
							1	1	9.5V to 12.6V, external source with 4:3 aspect ratio
VCR Slow Switch Input					0	0			0 to 2V, internal source
					0	1			4.5V to 7V, external source with 16:9 aspect ratio
					1	0			Not used
					1	1			9.5V to 12.6V, external source with 4:3 aspect ratio
Power-On Reset		0							V <sub>VID</sub> is too low for digital logic to operate
		1							V <sub>VID</sub> is high enough for digital logic to operate
Thermal Shutdown	0								The part is in thermal shutdown
	1								The temperature is below the TSHD limit

# Audio/Video Switch for Dual SCART Connectors

## Typical Application Circuits

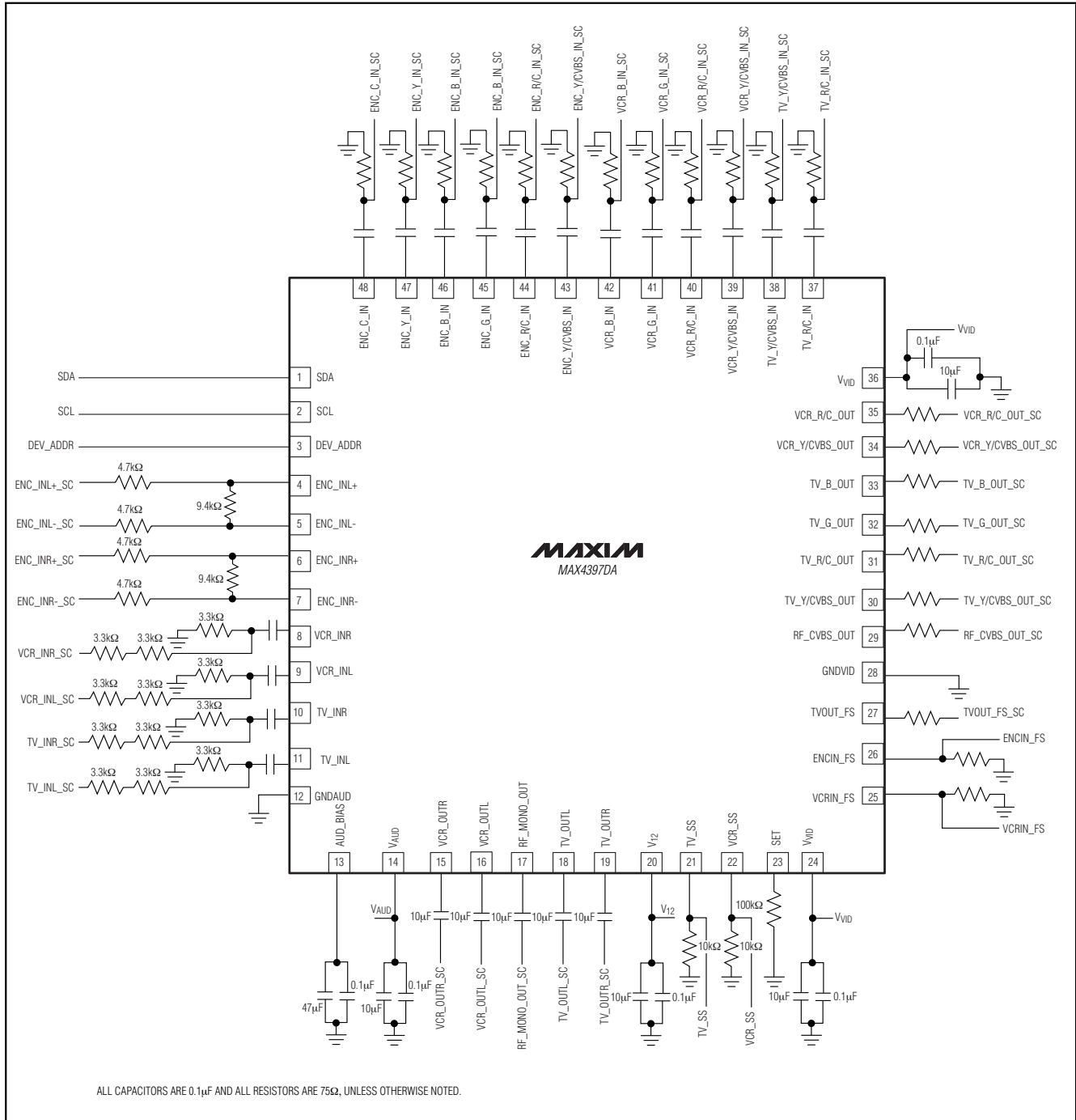

# Audio/Video Switch for Dual SCART Connectors

## Typical Application Circuits (continued)

**MAX4397DA/SA**

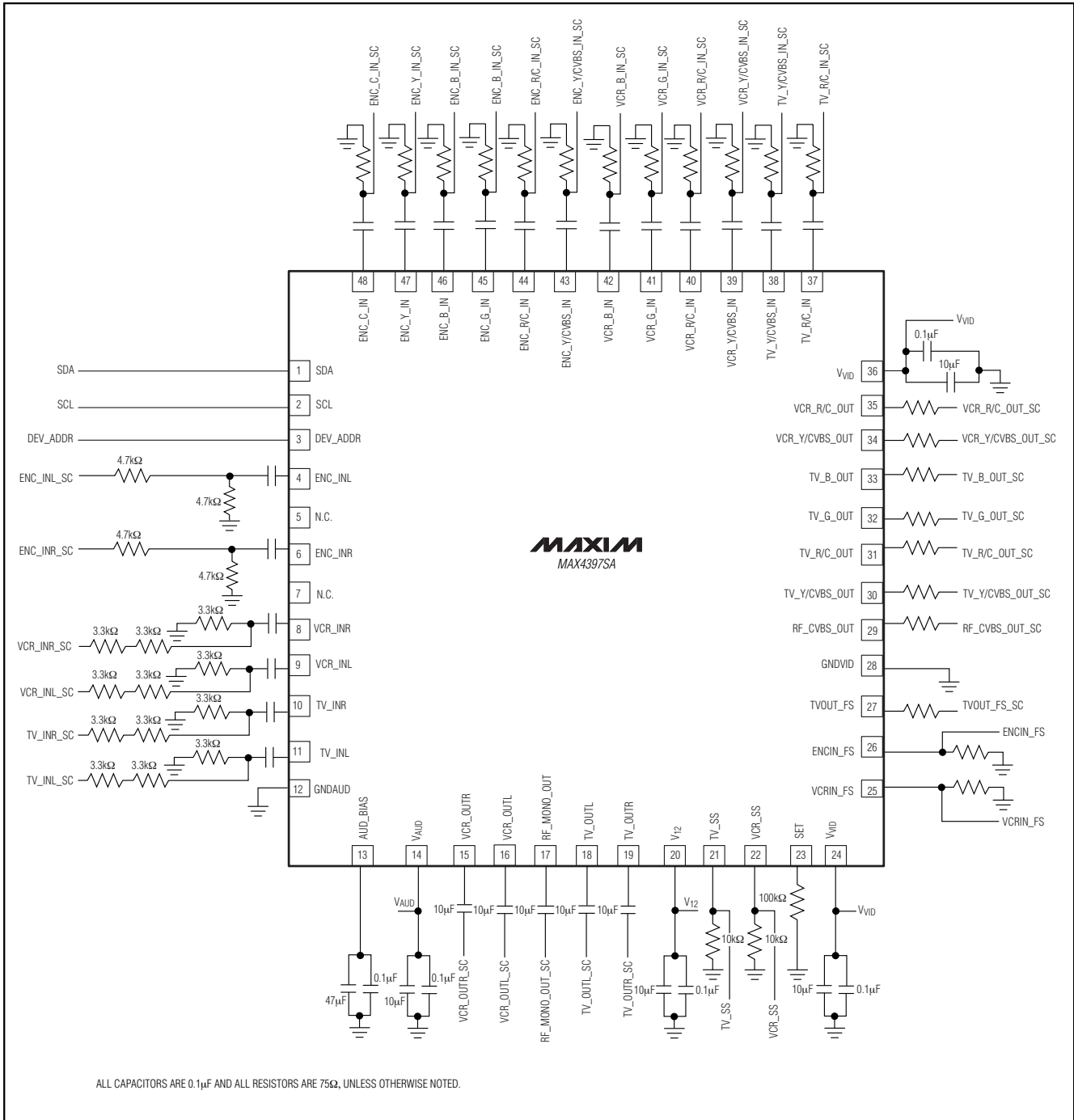

# Audio/Video Switch for Dual SCART Connectors

## System Block Diagram

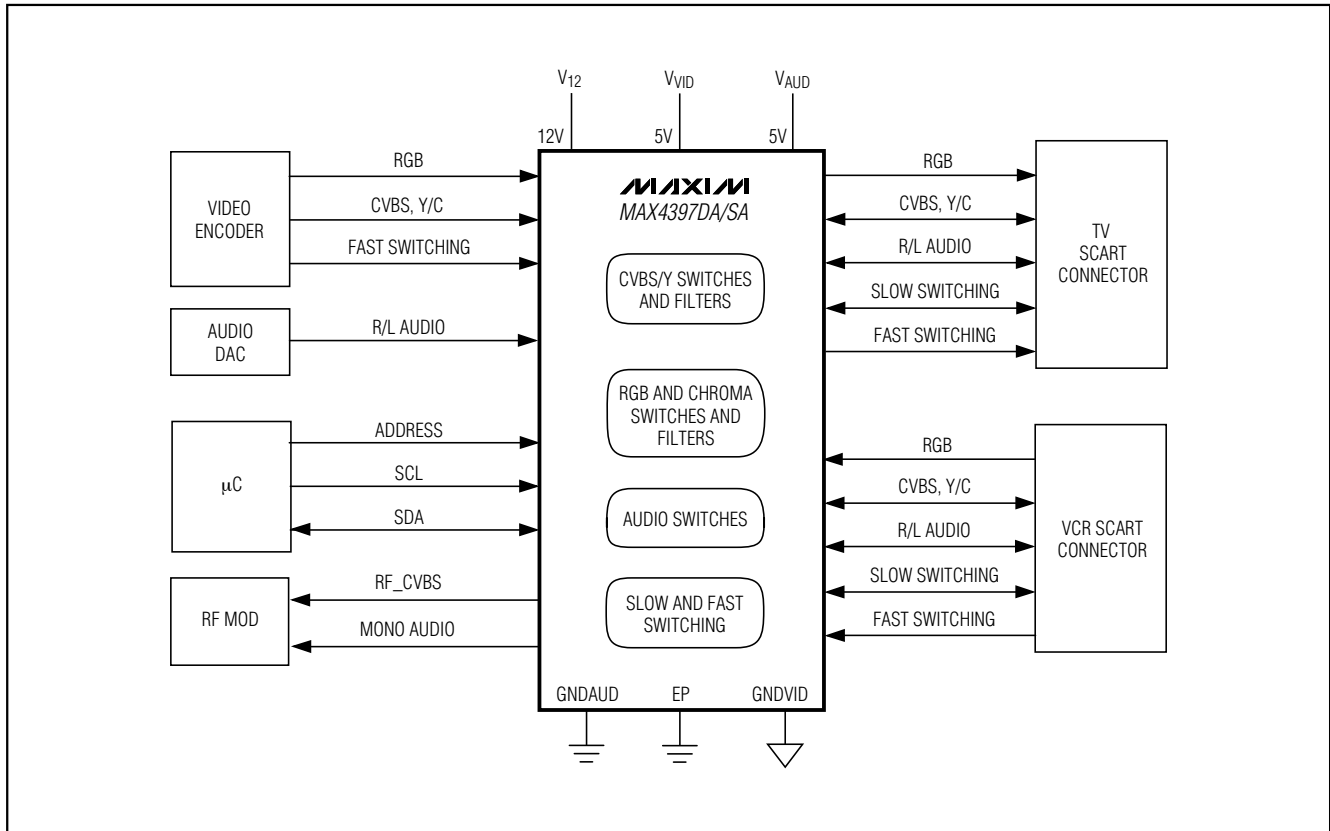

# Audio/Video Switch for Dual SCART Connectors

## Pin Configurations

**MAX4397DA/SA**

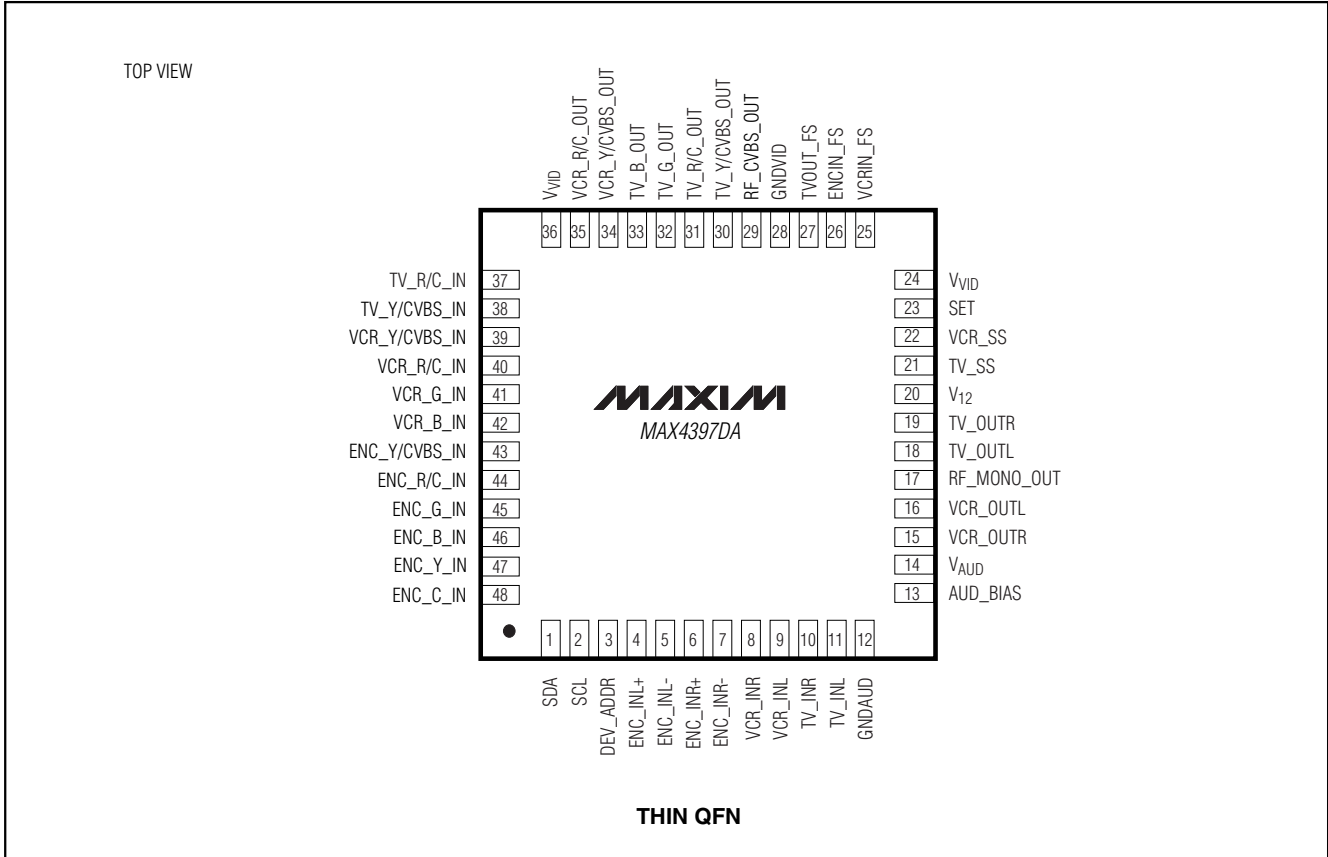

# Audio/Video Switch for Dual SCART Connectors

## Pin Configurations (continued)

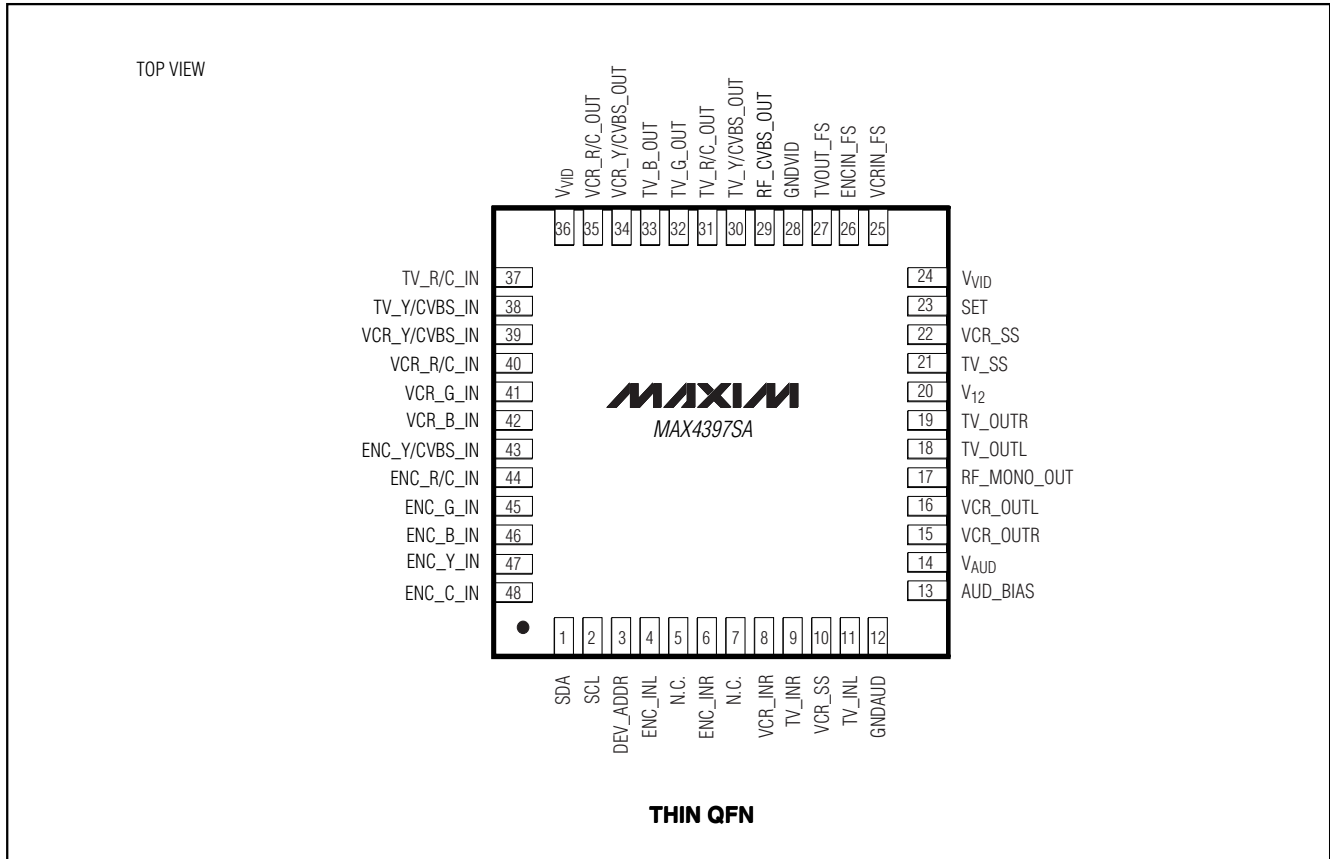

### Chip Information

TRANSISTOR COUNT: 13,265

PROCESS: BiCMOS



# Audio/Video Switch for Dual SCART Connectors

## Package Information (continued)

(The package drawing(s) in this data sheet may not reflect the most current specifications. For the latest package outline information go to [www.maxim-ic.com/packages](http://www.maxim-ic.com/packages).)

COMMON DIMENSIONS															
PKG	32L 7x7			44L 7x7			48L 7x7			CUSTOM PKG. (T4877-1) 48L 7x7			56L 7x7		
SYMBOL	MIN.	NOM.	MAX.	MIN.	NOM.	MAX.	MIN.	NOM.	MAX.	MIN.	NOM.	MAX.	MIN.	NOM.	MAX.
A	0.70	0.75	0.80	0.70	0.75	0.80	0.70	0.75	0.80	0.70	0.75	0.80	0.70	0.75	0.80
A1	0	0.02	0.05	0	0.02	0.05	0	0.02	0.05	0	0.02	0.05	0	-	0.05
A2	0.20 REF.			0.20 REF.			0.20 REF.			0.20 REF.			0.20 REF.		
b	0.25	0.30	0.35	0.20	0.25	0.30	0.20	0.25	0.30	0.20	0.25	0.30	0.15	0.20	0.25
D	6.90	7.00	7.10	6.90	7.00	7.10	6.90	7.00	7.10	6.90	7.00	7.10	6.90	7.00	7.10
E	6.90	7.00	7.10	6.90	7.00	7.10	6.90	7.00	7.10	6.90	7.00	7.10	6.90	7.00	7.10
e	0.65 BSC.			0.50 BSC.			0.50 BSC.			0.50 BSC.			0.40 BSC.		
k	0.25	-	-	0.25	-	-	0.25	-	-	0.25	-	-	0.25	-	-
L	0.45	0.55	0.65	0.45	0.55	0.65	0.30	0.40	0.50	0.45	0.55	0.65	0.30	0.40	0.50
N	32			44			48			44			56		
ND	8			11			12			10			14		
NE	8			11			12			12			14		

EXPOSED PAD VARIATIONS								
PKG. CODES	DEPOPULATED LEADS	D2			E2		JEDEC M022Q REV. C	
		MIN.	NOM.	MAX.	MIN.	NOM.		MAX.
T3277-2	-	4.55	4.70	4.85	4.95	4.70	4.85	-
T3277-3	-	4.55	4.70	4.85	4.55	4.70	4.85	-
T4477-2	-	4.55	4.70	4.85	4.55	4.70	4.85	WKKD-1
T4477-3	-	4.55	4.70	4.85	4.55	4.70	4.85	WKKD-1
T4877-1**	13,24,37,48	4.20	4.30	4.40	4.20	4.30	4.40	-
T4877-3	-	4.95	5.10	5.25	4.95	5.10	5.25	-
T4877-4	-	5.40	5.50	5.60	5.40	5.50	5.60	-
T4877-5	-	2.40	2.50	2.60	2.40	2.50	2.60	-
T4877-6	-	5.40	5.50	5.60	5.40	5.50	5.60	-
T4877-7	-	4.95	5.10	5.25	4.95	5.10	5.25	-
T4877M-1	-	5.40	5.50	5.60	5.40	5.50	5.60	-
T4877M-6	-	5.40	5.50	5.60	5.40	5.50	5.60	-
T4877MN-8	-	5.40	5.50	5.60	5.40	5.50	5.60	-
T5677-1	-	5.40	5.50	5.60	5.40	5.50	5.60	-
T5677-2	-	5.40	5.50	5.60	5.40	5.50	5.60	-

\*\* NOTE: T4877-1 IS A CUSTOM 48L PKG. WITH 4 LEADS DEPOPULATED. TOTAL NUMBER OF LEADS ARE 44.

**NOTES:**

- DIMENSIONING & TOLERANCING CONFORM TO ASME Y14.5M-1994.
- ALL DIMENSIONS ARE IN MILLIMETERS. ANGLES ARE IN DEGREES.
- N IS THE TOTAL NUMBER OF TERMINALS.
- THE TERMINAL #1 IDENTIFIER AND TERMINAL NUMBERING CONVENTION SHALL CONFORM TO JEDEC 95-1 SPP-012. DETAILS OF TERMINAL #1 IDENTIFIER ARE OPTIONAL, BUT MUST BE LOCATED WITHIN THE ZONE INDICATED. THE TERMINAL #1 IDENTIFIER MAY BE EITHER A MOLD OR MARKED FEATURE.
- DIMENSION b APPLIES TO METALLIZED TERMINAL AND IS MEASURED BETWEEN 0.25 mm AND 0.30 mm FROM TERMINAL TIP.
- ND AND NE REFER TO THE NUMBER OF TERMINALS ON EACH D AND E SIDE RESPECTIVELY.
- DEPOPULATION IS POSSIBLE IN A SYMMETRICAL FASHION.
- COPLANARITY APPLIES TO THE EXPOSED HEAT SINK SLUG AS WELL AS THE TERMINALS.
- DRAWING CONFORMS TO JEDEC M022Q EXCEPT THE EXPOSED PAD DIMENSIONS OF T4877-1/-3/-4/-5/-6 & T5677-1.
- WARPAGE SHALL NOT EXCEED 0.10 mm.
- MARKING IS FOR PACKAGE ORIENTATION REFERENCE ONLY
- NUMBER OF LEADS SHOWN ARE FOR REFERENCE ONLY

**-DRAWING NOT TO SCALE-**

TITLE: PACKAGE OUTLINE 32, 44, 48, 56L THIN QFN, 7x7x0.8mm	
APPROVAL:	DOCUMENT CONTROL NO. 21-0144
REV: F	2/2

## Revision History

Pages changed at Rev 1: 1, 2, 17, 26, 29, 30

Maxim cannot assume responsibility for use of any circuitry other than circuitry entirely embodied in a Maxim product. No circuit patent licenses are implied. Maxim reserves the right to change the circuitry and specifications without notice at any time.

30 **Maxim Integrated Products, 120 San Gabriel Drive, Sunnyvale, CA 94086 408-737-7600**

## Looking for pricing, stock, or lifecycle information?

Click below to explore more details on WIN SOURCE:

- ⊖ [View MAX4397DCTM+](#) on WIN SOURCE
- ⊖ [Maxim Integrated](#) Information

## Optimize Your Supply Chain with WIN SOURCE Solutions

- ✓ Global Sourcing Solution
- ✓ Obsolete Management
- ✓ Cost Control Management
- ✓ Shortage Management
- ✓ Alternative Solution
- ✓ Excess Inventory Management