



**THE DATASHEET OF
MAX4370ESA+T**





Current-Regulating Hot-Swap Controller with DualSpeed/BiLevel Fault Protection

MAX4370

General Description

The MAX4370 is a circuit-breaker IC designed to offer protection in hot-swap applications using Maxim's DualSpeed/BiLevel™ detection. This controller, designed to reside either on the backplane or on the removable card, is used to protect a system from start-up damage when a card or board is inserted into a rack with the main system power supply turned on. The card's discharged filter capacitors provide a low impedance that can momentarily cause the main power supply to collapse. The MAX4370 prevents this start-up condition by providing inrush current regulation during a programmable start-up period, allowing the system to stabilize safely. In addition, two on-chip comparators provide DualSpeed/BiLevel short-circuit protection and overcurrent protection during normal operation.

The MAX4370 provides protection for a +3V to +12V single supply. An internal charge pump generates the controlled gate drive for an external N-channel MOSFET power switch. The MAX4370 latches the switch off after a fault condition until an external reset signal clears the device. Other features include a status pin to indicate a fault condition, an adjustable overcurrent response time, and a power-on reset comparator.

The MAX4370 is specified for the extended-industrial temperature range (-40°C to +85°C) and is available in an 8-pin SO package.

Applications

Hot Board Insertion
Solid-State Circuit Breaker

Features

- ◆ DualSpeed/BiLevel Protection During Normal Operation
- ◆ Inrush Current Regulated at Start-Up
- ◆ Resides Either on the Backplane or on the Removable Card
- ◆ Programmable Start-Up Period and Response Time
- ◆ Allows Safe Board Insertion and Removal from Live Backplane
- ◆ Protection for +3V to +12V Single Supplies
- ◆ Latched Off After Fault Condition
- ◆ Status Output Pin
- ◆ Internal Charge Pump Generates Gate Drive for External N-Channel MOSFET

Ordering Information

PART	TEMP. RANGE	PIN-PACKAGE
MAX4370ESA	-40°C to +85°C	8 SO

Pin Configuration appears at end of data sheet.

Typical Operating Circuit

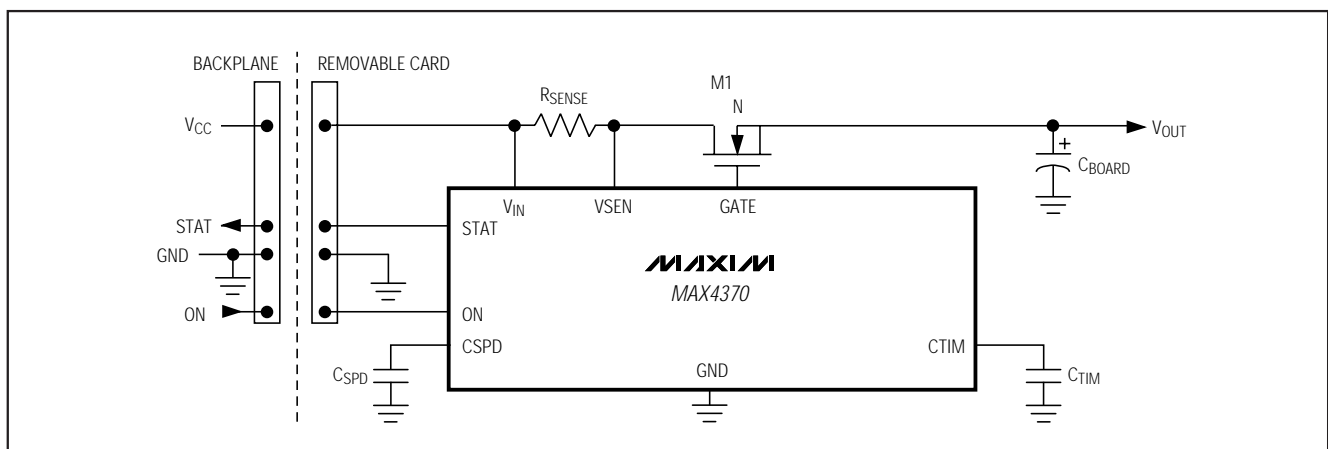

DualSpeed/BiLevel is a trademark of Maxim Integrated Products.



Maxim Integrated Products 1

For free samples & the latest literature: <http://www.maxim-ic.com>, or phone 1-800-998-8800.
For small orders, phone 1-800-835-8769.

Current-Regulating Hot-Swap Controller with DualSpeed/BiLevel Fault Protection

ABSOLUTE MAXIMUM RATINGS

V _{IN} to GND.....	+15V	Current into Any Other Pin.....	±50mA
STAT to GND.....	-0.3V to +14V	Continuous Power Dissipation (T _A = +70°C)	
GATE to GND.....	-0.3V to (V _{IN} + 8.5V)	SO (derate 5.9mW/°C above +70°C).....	471mW
ON to GND (Note 1).....	-1V to +14V	Operating Temperature Range.....	-40°C to +85°C
CSPD to GND.....	-0.3V to the lower of (V _{IN} + 0.3V) or +12V	Storage Temperature Range.....	-65°C to +150°C
VSEN, CTIM to GND.....	-0.3V to (V _{IN} + 0.3V)	Lead Temperature (soldering, 10sec).....	+300°C
Current into ON.....	±2mA		

Note 1: ON can be pulled below ground. Limiting the current to 2mA ensures that this pin is never lower than about -0.8V.

Stresses beyond those listed under "Absolute Maximum Ratings" may cause permanent damage to the device. These are stress ratings only, and functional operation of the device at these or any other conditions beyond those indicated in the operational sections of the specification is not implied. Exposure to absolute maximum rating conditions for extended periods may affect device reliability.

ELECTRICAL CHARACTERISTICS

(V_{IN} = +2.7V to +13.2V, T_A = -40°C to +85°C, unless otherwise noted. Typical values are at V_{IN} = +5V and T_A = +25°C.) (Note 2)

PARAMETER	SYMBOL	CONDITIONS	MIN	TYP	MAX	UNITS	
POWER SUPPLIES							
Input Voltage Range	V _{IN}		2.7		13.2	V	
Supply Current	I _Q	ON = V _{IN}		0.6	1	mA	
CURRENT CONTROL							
Slow Comparator Threshold	V _{SC,TH}	V _{IN} - V _{SEN}	T _A = +25°C	45	50	55	mV
			T _A = T _{MIN} to T _{MAX}	43.5		56	
Slow Comparator Response Time	t _{CSPD}	CSPD = floating	10	20	40	μs	
		100nF on CSPD to GND	10	20	40	ms	
Fast Comparator Threshold	V _{FC,TH}	V _{IN} - V _{SEN}	180	200	220	mV	
Fast Comparator Response Time	t _{FCD}	10mV overdrive, from overload condition to GATE discharging		460		ns	
VSEN Input Bias Current	I _{B,VSEN}	VSEN = V _{IN}		0.2	10	μA	
MOSFET DRIVER							
Start-Up Period (Note 3)	t _{START}	100nF on CTIM	21	31	41	ms	
		CTIM = floating		5.5		μs	
Gate Charge Current	I _{GATE}	V _{GATE} = V _{IN} (Note 4)		100		μA	
Turn-Off Time	t _{OFF}	Time from current overload to V _{GATE} < 0.1V, C _{GATE} = 1000pF to GND (triggered by the fast comparator during normal operation)		60		μs	
Gate Discharge Current	I _{GATE,DIS}	During start-up (current regulation provided by fast comparator)		80		μA	
		During turn-off, triggered by a fault in normal operation or ON falling edge	75	225	550		
Maximum Gate Voltage		Measured with respect to V _{IN} ; voltage at which internal clamp circuitry is triggered		6.7	7.5	V	
Minimum Gate Drive Voltage		I _{GATE} = 8.5μA, measured above V _{IN}	V _{IN} ≥ 5V	5		V	
			V _{IN} ≥ 2.7V	2.7			
Gate Overvoltage Threshold		Start-up is initiated only if V _{GATE} is less than this voltage	0.1			V	

Current-Regulating Hot-Swap Controller with DualSpeed/BiLevel Fault Protection

MAX4370

ELECTRICAL CHARACTERISTICS (continued)

($V_{IN} = +2.7V$ to $+13.2V$, $T_A = -40^{\circ}C$ to $+85^{\circ}C$, unless otherwise noted. Typical values are at $V_{IN} = +5V$ and $T_A = +25^{\circ}C$.) (Note 2)

PARAMETER	SYMBOL	CONDITIONS	MIN	TYP	MAX	UNITS
ON COMPARATOR						
Threshold Voltage	$V_{TH,ON}$	$V_{IN} = 5V$, rising threshold	0.575	0.6	0.625	V
Hysteresis	V_{HYST}			3		mV
Power-Supply Rejection Ratio	PSRR	$2.7V \leq V_{IN} \leq 13.2V$		0.1	1	mV/V
Propagation Delay	$t_{D,COMP}$	10mV overdrive		10		μs
Input Voltage Range	V_{ON}	Input can be driven to the absolute maximum limit without false output inversion	-0.1		13.2	V
Input Bias Current	$I_{B,ON}$			0.001	1	μA
ON Pulse Width Low	$t_{RESTART}$	To restart after a fault	20			μs
DIGITAL OUTPUT (STAT)						
Output Leakage Current		$V_{STAT} \leq +13.2V$			1	μA
Output Voltage Low	V_{OL}	$I_{SINK} = 1mA$			0.4	V
V_{IN} UNDERVOLTAGE LOCKOUT						
Threshold	V_{UVLO}	Start-up is initiated when this threshold is reached at V_{IN}	2.25		2.67	V
Hysteresis	$V_{UVLO,HYST}$			100		mV
UVLO to Start-Up Delay	$t_{D,UVLO}$	Time which input voltage must exceed under-voltage lockout before start-up is initiated	100	150	200	ms

Note 2: All devices are 100% tested at $T_A = +25^{\circ}C$. All temperature limits are guaranteed by design.

Note 3: The start-up period (t_{START}) is the time during which the slow comparator is ignored and the device acts as a current limiter by regulating the sense current with the fast comparator. It is measured from ON rising above 0.6V to STAT rising.

Note 4: The current available at GATE is a function of V_{GATE} (see Typical *Operating Characteristics*.)

Current-Regulating Hot-Swap Controller with DualSpeed/BiLevel Fault Protection

Typical Operating Characteristics

(Circuit of Figure 7, $V_{IN} = 5V$, $R_{SENSE} = 100m\Omega$, $M1 = FDS6670A$, $C_{BOARD} = 470\mu F$, $C_{GATE} = 0$, $R_S = 0$, $T_A = +25^\circ C$, unless otherwise noted.)

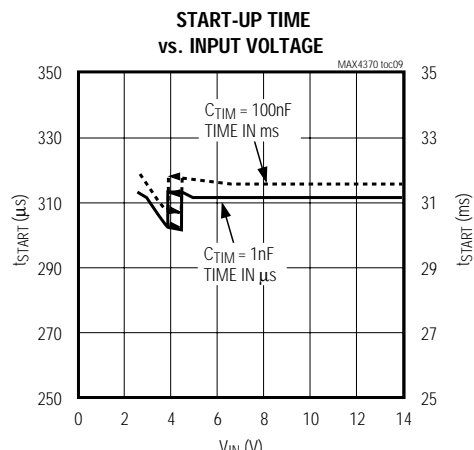
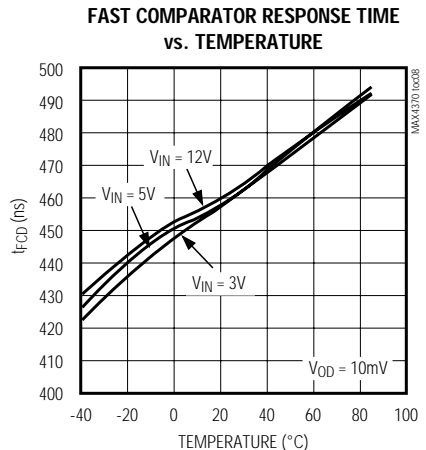
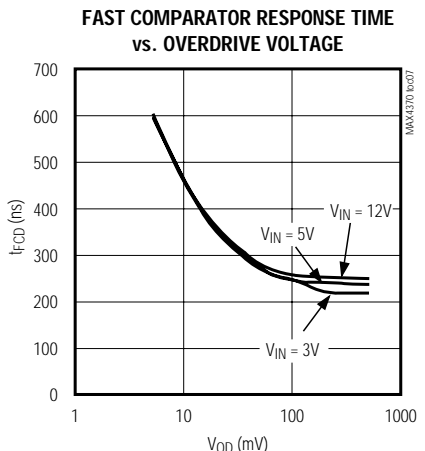
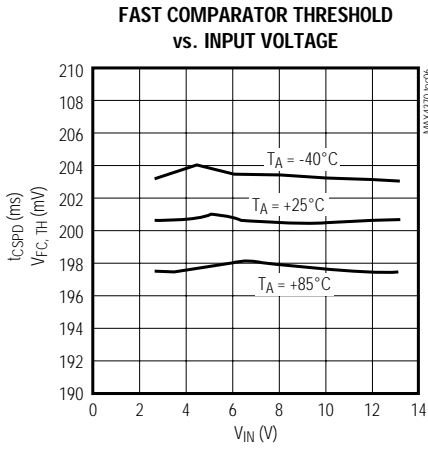
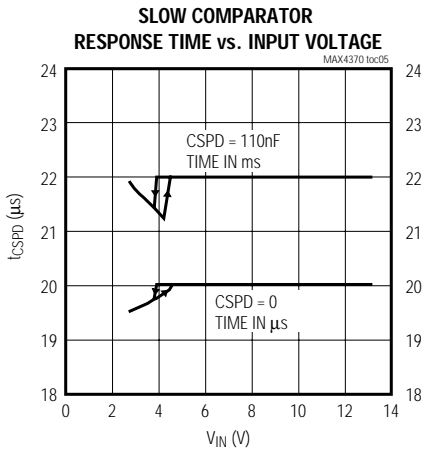
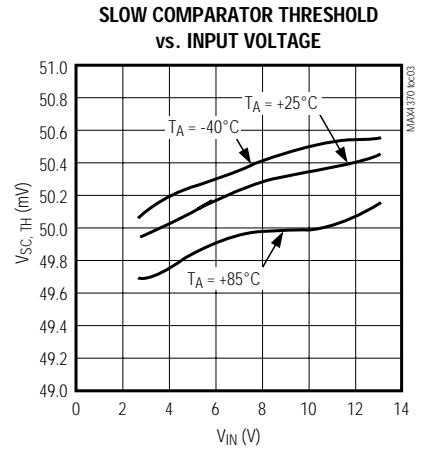
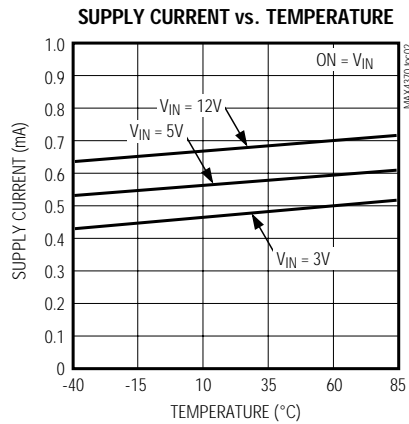
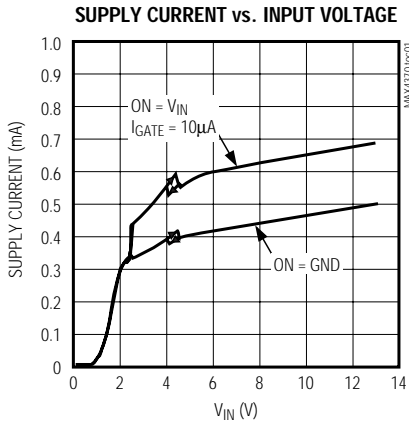

Current-Regulating Hot-Swap Controller with DualSpeed/BiLevel Fault Protection

MAX4370

Typical Operating Characteristics (continued)

(Circuit of Figure 7, $V_{IN} = 5V$, $R_{SENSE} = 100m\Omega$, $M1 = FDS6670A$, $C_{BOARD} = 470\mu F$, $C_{GATE} = 0$, $R_S = 0$, $T_A = +25^\circ C$, unless otherwise noted.)

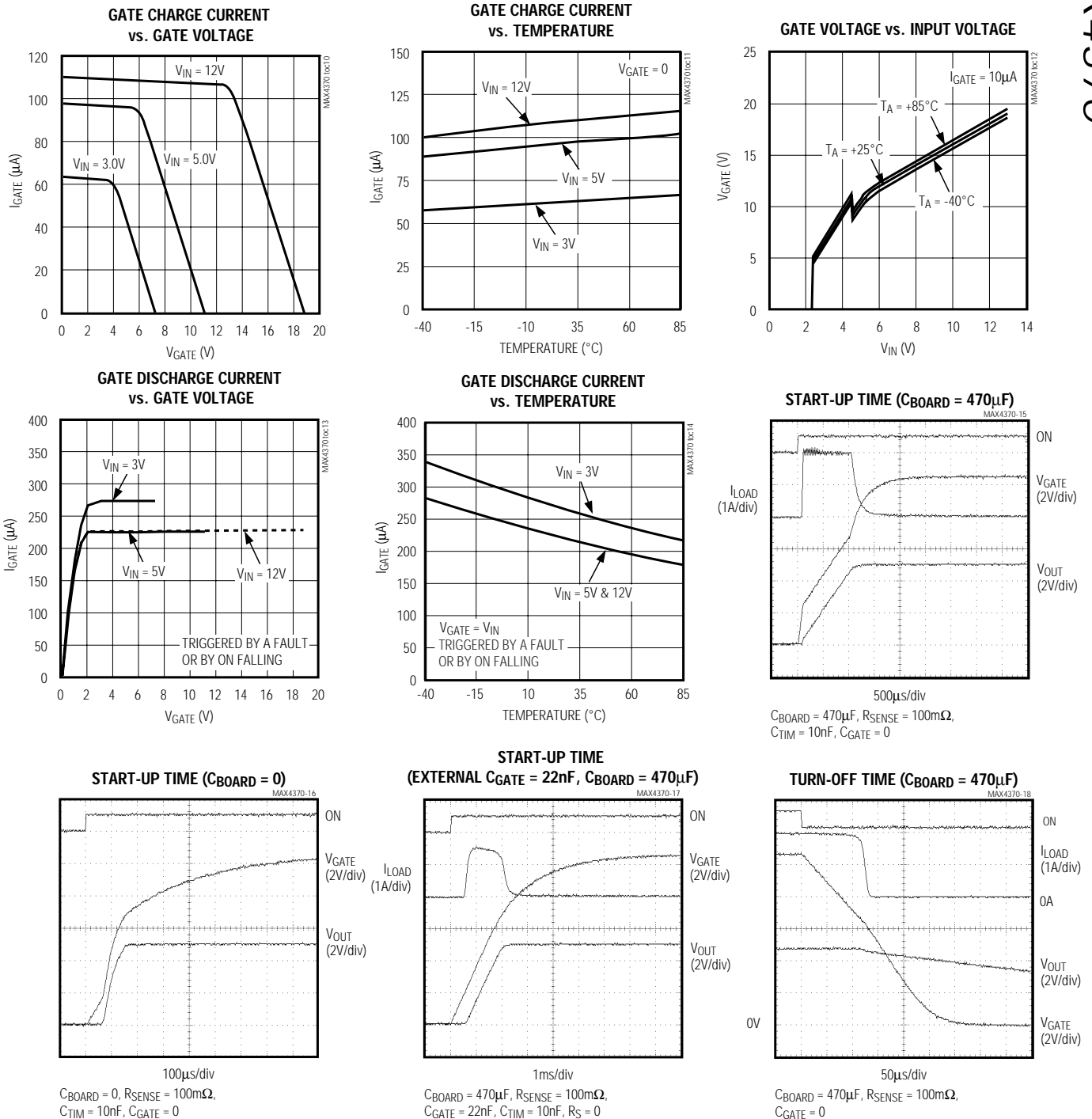

Current-Regulating Hot-Swap Controller with DualSpeed/BiLevel Fault Protection

Typical Operating Characteristics (continued)

(Circuit of Figure 7, $V_{IN} = 5V$, $R_{SENSE} = 100m\Omega$, M1 = FDS6670A, $C_{BOARD} = 470\mu F$, $C_{GATE} = 0$, $R_S = 0$, $T_A = +25^\circ C$, unless otherwise noted.)

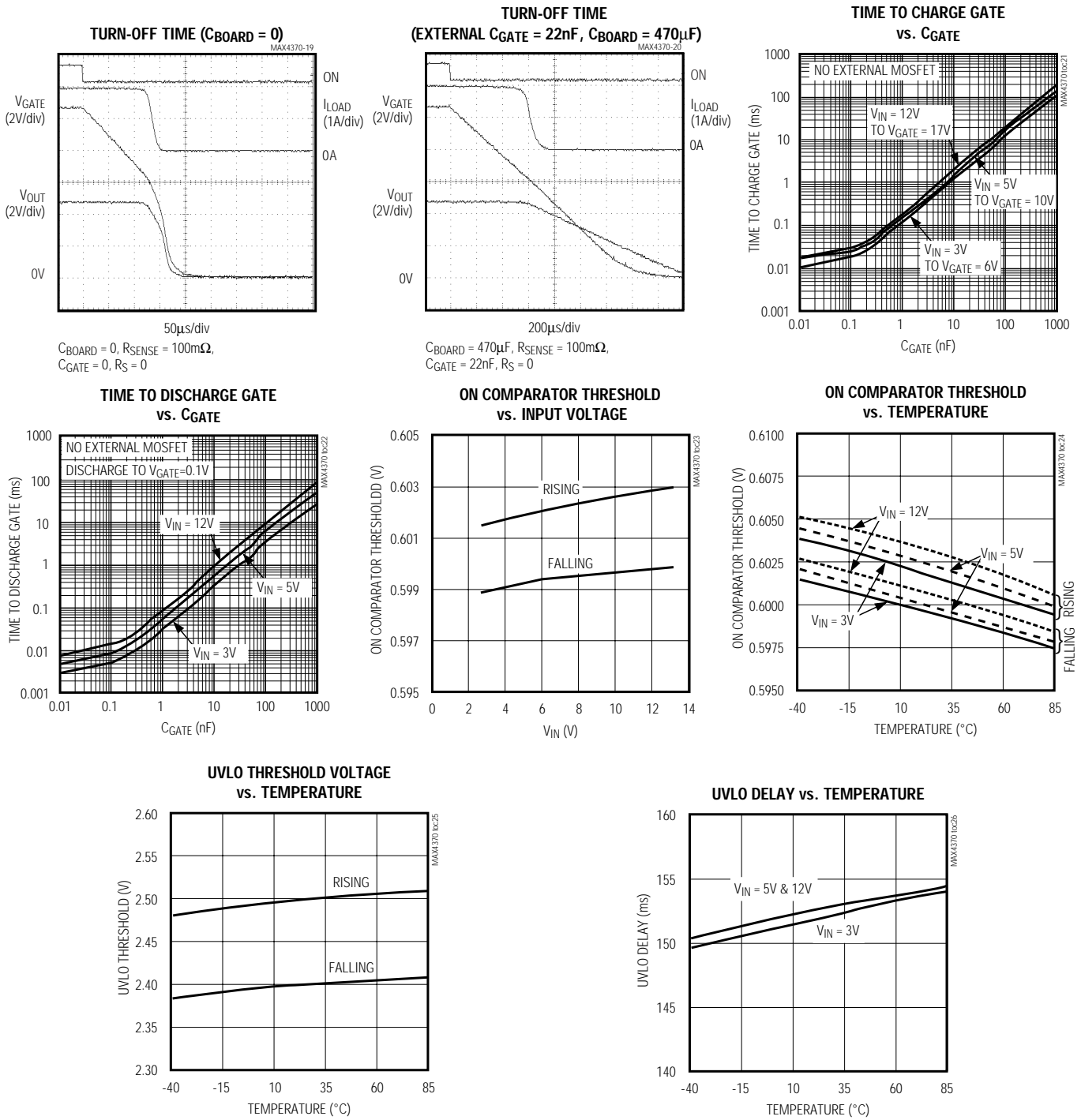

Current-Regulating Hot-Swap Controller with DualSpeed/BiLevel Fault Protection

Pin Description

MAX4370

PIN	NAME	FUNCTION
1	V _{IN}	Supply Voltage Input. Connect to 2.7V to 13.2V.
2	VSEN	Current-Sense Resistor Voltage Input. R _{SENSE} is connected from V _{IN} to VSEN.
3	GATE	Gate Drive Output. Connect to gate of external N-channel MOSFET.
4	GND	Ground
5	CSPD	Slow Comparator Speed Setting. Leave floating or connect the timing capacitor from CSPD to GND. See <i>Slow Comparator Response Time</i> section.
6	CTIM	Start-Up Timer Setting. Leave floating or connect the timing capacitor from CTIM to GND. See <i>Start-Up Timing Capacitor</i> section.
7	STAT	Status Output—open drain. High indicates start-up completed with no fault. See Table 1.
8	ON	ON Comparator Input. Connect high for normal operation; connect low to force the MOSFET off. Comparator threshold V _{TH,ON} = 0.6V allows for precise control over shutdown feature. Pulse ON low for at least 20μs, then high to restart after a fault.

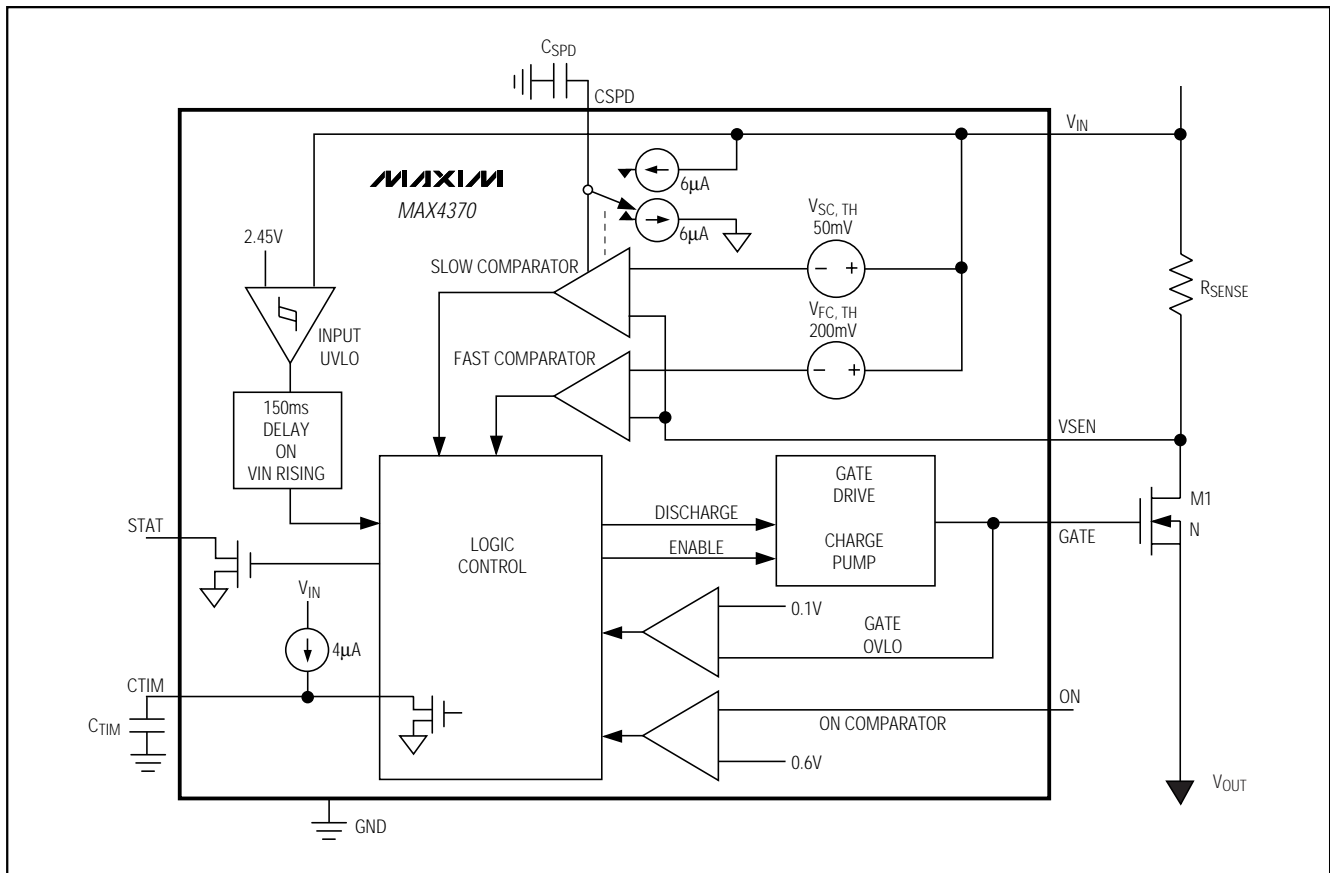

Figure 1. Functional Diagram

Current-Regulating Hot-Swap Controller with DualSpeed/BiLevel Fault Protection

Detailed Description

The MAX4370 is a circuit-breaker IC designed for hot-swap applications where a card or board is to be inserted into a rack with the main system power supply turned on. Normally, when a card is plugged into a live backplane, the card is discharged filter capacitors provide a low impedance, which can momentarily cause the main power supply to collapse. The MAX4370 is designed to reside either in the backplane or in the removable card to provide inrush-current limiting and short-circuit protection. This is achieved using a charge pump as gate drive for an external N-channel MOSFET, an external current-sense resistor, and two on-chip comparators. Figure 1 shows the device's functional diagram.

The slow comparator response time and the start-up timer can be adjusted with external capacitors. The timing components are optional; without them the part is set to its nominal values, as shown in the *Electrical Characteristics*.

Start-Up Period

CTIM sets the start-up period. This mode starts when the power is first applied to V_{IN} if ON is connected to V_{IN} , or at the rising edge of ON. In addition, the voltage at V_{IN} must be above the undervoltage lockout for 150ms (see *Undervoltage Lockout*).

During start-up, the slow comparator is disabled and current limiting is provided two different ways:

- 1) Slow ramping of the current to the load by controlling the external MOSFET gate voltage.
- 2) Limiting the current to the load by regulating the voltage across the external current-sense resistor.

Unlike other circuit-breaker ICs, the MAX4370 hot-swap controller regulates the current to a preset level instead of completely turning off if an overcurrent occurs during start-up.

In start-up mode, the gate drive current is limited to $100\mu\text{A}$ and decreases with the increase of the gate voltage (see *Typical Operating Characteristics*). This allows the MAX4370 to slowly enhance the MOSFET. If the fast comparator detects an overcurrent, the gate voltage is momentarily discharged with a fixed $80\mu\text{A}$ current until the load current through the sense resistor (R_{SENSE}) decreases below its threshold point. This effectively regulates the turn-on current during start-up. Figure 2 shows the start-up waveforms. STAT goes high at the end of the start-up period if no fault condition is present.

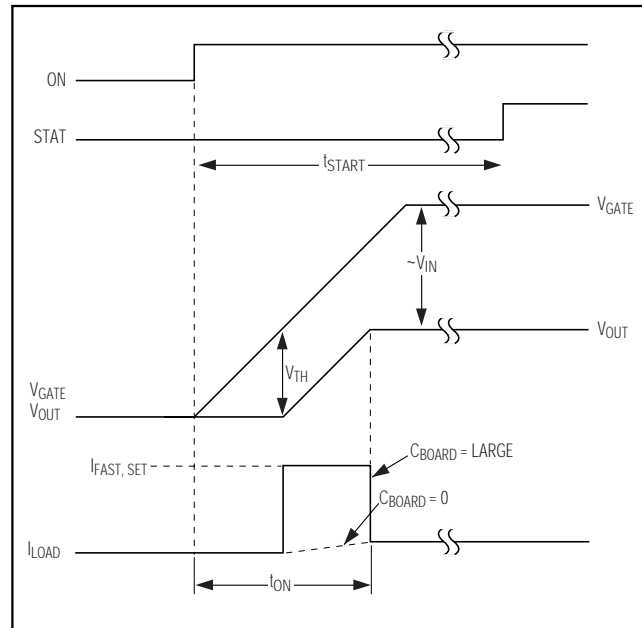

Figure 2. Start-Up Waveforms

Normal Operation (DualSpeed/BiLevel)

In normal operation (after the start-up period has expired), protection is provided by turning off the external MOSFET when a fault condition is encountered. DualSpeed/BiLevel fault protection incorporates two comparators with different thresholds and response times to monitor the load current:

- 1) Slow Comparator. This comparator has an externally set response time ($20\mu\text{s}$ to seconds) and a fixed 50mV threshold voltage. The slow comparator ignores low-amplitude momentary current glitches. After an extended overcurrent condition, a fault is detected and the MOSFET gate is discharged.
- 2) Fast Comparator. This comparator has a fixed response time and a higher 200mV threshold voltage. The fast comparator turns off the MOSFET immediately after it detects a large amplitude event such as a short circuit.

In each case, when a fault is encountered, the status pin (STAT) goes low and the MAX4370 stays latched off. Figure 3 shows the waveforms after a fault condition.

Current-Regulating Hot-Swap Controller with DualSpeed/BiLevel Fault Protection

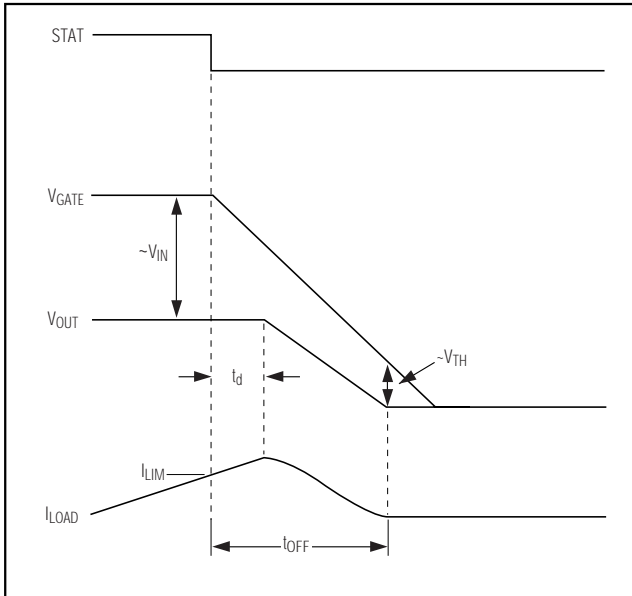

Figure 3. Response to a Fault Condition

Slow Comparator

The slow comparator is disabled at start-up while the external MOSFET is turning on. This allows the part to ignore the higher-than-normal inrush current charging the board capacitors (C BOARD) when a card is first plugged in.

If the slow comparator detects an overload current while in normal operation (after start-up is completed), it turns off the external MOSFET by discharging the gate capacitance with a 200 μ A current. The slow comparator threshold is set at 50mV and has a default delay of 20 μ s (CSPD floating), allowing it to ignore power-supply glitches and noise. The response time can be lengthened with an external capacitor at CSPD (Figure 8).

If the overcurrent condition is not continuous, the duration above the threshold minus the duration below it must be greater than 20 μ s (or the external programmed value) for the device to trip. When the current is above the threshold, CSPD is charged with a 6 μ A current source; when the current is below the threshold, CSPD is discharged with a 6 μ A current source. A fault is detected when CSPD is charged to the trip point of 1.2V. A pulsing current with a duty cycle greater than

50% (i.e., > 50% of the time the current is above the threshold level) will be considered a fault condition even if it is never higher than the threshold for more than the slow comparator's set response time.

Once the fault condition is detected, the STAT pin goes low and the device goes into latched mode. The GATE voltage discharge rate depends on the gate capacitance and the external capacitance at GATE.

Fast Comparator

The fast comparator behaves differently according to the operating mode. During start-up, the fast comparator is part of a simple current regulator. When the sensed current is above the threshold ($V_{FC,TH} = 200\text{mV}$), the gate is discharged with a 80 μ A current source. When the sensed current drops below the threshold, the charge pump turns on again. The sensed current will rise and fall near the threshold due to the fast comparator and charge-pump propagation delay. The gate voltage will be roughly saw-tooth shaped, and the load current will present a 20% ripple. The ripple can be reduced by adding a capacitor from GATE to GND. Once C BOARD is completely charged, the load current drops to its normal operating levels. If the sensed current is still high after the start-up timer expires, the MOSFET gate is discharged completely.

In normal operation (after start-up), the fast comparator is used as an emergency off switch. If the load current reaches the fast comparator threshold, the device immediately forces the MOSFET off completely by discharging the GATE with a 200 μ A current. This can occur in the event of a serious current overload or a dead short. Given a 1000pF gate capacitance and 12V gate voltage, the MOSFET will be off in less than 60 μ s. Any additional capacitance connected between GATE and GND to slow down the turn-on time also increases the turn-off time.

Latched Mode and Reset

The MOSFET driver of the MAX4370 stays latched off after a fault condition until it is reset by a negative-going pulse on the ON pin. Pulse ON low for 20 μ s (min), then high to restart after a fault. During start-up, a negative-going edge on ON will force the device to turn off the MOSFET and place the device in latched mode. Keep ON low for 20 μ s (min) to restart.

Current-Regulating Hot-Swap Controller with DualSpeed/BiLevel Fault Protection

Status Output

The status output is an open-drain output that goes low when the part is:

- 1) in start-up
- 2) forced off (on = GND)
- 3) in an overcurrent condition, or
- 4) latched off.

STAT is high only if the part is in normal mode and no faults are present (Table 1). Figure 4 shows the STAT timing diagram.

Over/Undervoltage Lockouts

The undervoltage lockout prevents the MAX4370 from turning on the external MOSFET until the input voltage at V_{IN} exceeds the lockout threshold (2.25V min) for at least 150ms. The undervoltage lockout protects the external MOSFET from insufficient gate drive voltage. The 150ms timeout ensures that the board is fully plugged into the backplane and that V_{IN} is stable. Voltage transients at V_{IN} with voltages below the UVLO will reset the device and initiate a start-up sequence.

The device also features a gate overvoltage lockout that prevents the device from restarting after a fault condition if the discharge has not been completed. V_{GATE} must be discharged to below 0.1V before restarting. Since the MAX4370 does not monitor the output voltage, a start-up sequence can be initiated while the board capacitance is still charged.

Gate Overvoltage Protection

Newer-generation MOSFETs have an absolute maximum rating of $\pm 8V$ for the gate-to-source voltage (V_{GS}). To protect these MOSFETs, the MAX4370 limits the gate-to-drain (V_{GD}) to +7.5V with an internal zener diode. No protection is provided for negative V_{GD} . If V_{GATE} can be discharged to GND faster than the output voltage, an external small-signal protection diode (D1) can be used, as shown in Figure 5.

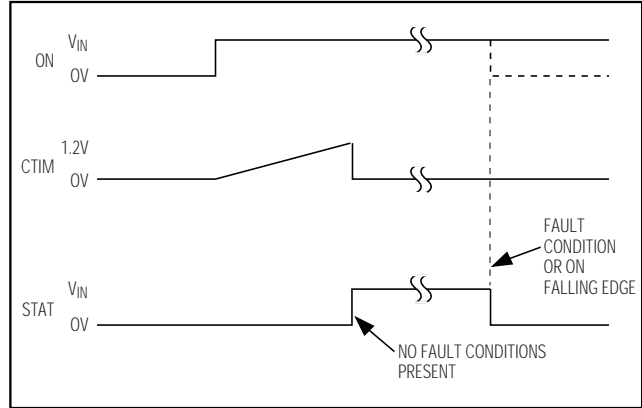

Figure 4. Status Output (STAT) Timing Diagram

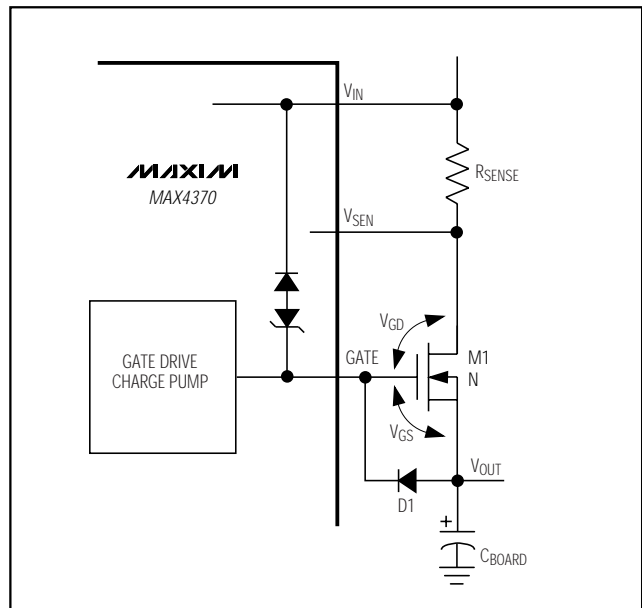

Figure 5. External Gate-Source Protection

Table 1. Status Output Truth Table

PART IN START-UP	ON PIN	OVERCURRENT CONDITION ON V_{IN}	PART IN LATCHED-OFF MODE DUE TO OVERCURRENT CONDITION	STAT PIN (STATUS)
Yes	X	X	X	Low
No	Low	X	X	Low
No	High	Yes	X	Low
No	High	No	Yes	Low
No	High	No	No	High

X = Don't care

Current-Regulating Hot-Swap Controller with DualSpeed/BiLevel Fault Protection

Applications Information

Component Selection

N-Channel MOSFET

Select the external N-channel MOSFET according to the application's current level. The MOSFET's $R_{DS(ON)}$ should be chosen low enough to have a minimum voltage drop at full load to limit the MOSFET power dissipation. High $R_{DS(ON)}$ can cause output ripple if the board has pulsing loads, or it can trigger an external under-voltage reset monitor at full load. Determine the device's power rating requirement to accommodate a short-circuit condition on the board during start-up (see *MOSFET Thermal Considerations*).

MOSFETs can typically withstand single-shot pulses with higher dissipation than the specified package rating. Also, since part of the inrush current limiting is achieved by limiting the gate dV/dt , it is not necessary to use a MOSFET with low gate capacitance. Table 2 lists some recommended manufacturers and components.

Sense Resistor

The slow comparator threshold voltage is set at 50mV. Select a sense resistor that causes a 50mV voltage drop at a current level above the maximum normal operating current. Typically, set the overload current at 1.2 to 1.5 times the nominal load current. The fast comparator threshold is set at 200mV. This sets the fault current limit at four times the overload current limit.

Choose the sense-resistor power rating to accommodate the overload current (Table 3):

$$P_{SENSE} = (I_{OVERLOAD})^2 \cdot R_{SENSE}$$

Start-Up Timing Capacitor (C_{TIM})

The start-up period (t_{START}) is determined by the capacitor connected at C_{TIM} . This determines the maximum time allowed to completely turn on the MOSFET.

The default value for t_{START} is chosen by leaving C_{TIM} floating and is approximately 5.5 μs . This is also the minimum value (not controlled and dependent on stray

capacitance). Longer timings are determined by the value of the capacitor, according to Figure 6, and can be determined as follows:

$$t_{START} \text{ (ms)} = 0.31 \cdot C_{TIM} \text{ (nF)}$$

Set the t_{START} timer to allow the MOSFET to be enhanced and the load capacitor to be completely charged.

There are two methods of completing the start-up sequences. Case A describes a start-up sequence that does not use the current-limiting feature and slowly turns on the MOSFET by limiting the gate dV/dt . Case B uses the current-limiting feature and turns on the MOSFET as fast as possible while still preventing high inrush current.

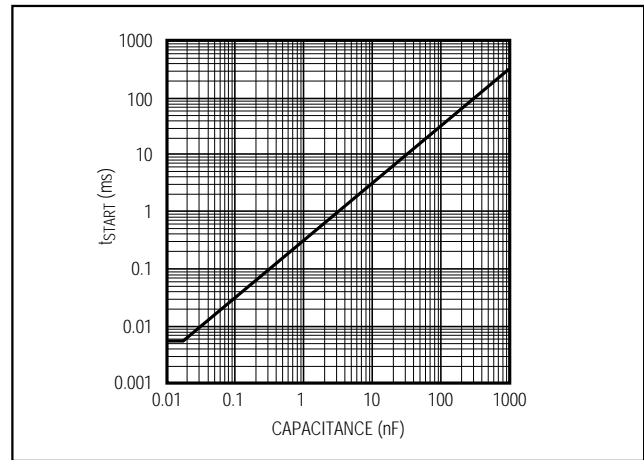

Figure 6. Start-Up Period vs. C_{TIM}

Table 3. Current Levels vs. R_{SENSE}

R_{SENSE} (m Ω)	OVERLOAD THRESHOLD SET BY SLOW COMPARATOR (A)	FAULT CURRENT THRESHOLD SET BY FAST COMPARATOR (A)
10	5	20
50	1	4
100	0.5	2

Table 2. Component Manufacturers

COMPONENT	MANUFACTURER	PHONE	INTERNET
Sense Resistors	Dale-Vishay	402-564-3131	www.vishay.com
	IRC	704-264-8861	www.irctt.co
MOSFETs	Fairchild	888-522-5372	www.fairchildsemi.com
	International Rectifier	310-322-3331	www.irf.com
	Motorola	602-244-3576	www.mot-sps.com/ppd/

Current-Regulating Hot-Swap Controller with DualSpeed/BiLevel Fault Protection

Case A: Slow Turn-On (without overcurrent)

There are two ways to turn on the MOSFET without reaching the fast comparator current limit:

- 1) If the board capacitance (C_{BOARD}) is low, the inrush current is low.
- 2) If the capacitance at GATE is high, the MOSFET turns on slowly.

In both cases, the turn-on (t_{ON}) is determined only by the charge required to enhance the MOSFET—effectively, the small gate-charging current limits the output voltage dv/dt . This time can be extended by connecting an external capacitor between GATE and GND, as shown in Figure 7. The turn-on time is dominated by the external gate capacitance if its value is considerably higher than MOSFET gate capacitance. Table 4 shows the timing required to enhance the recommended MOSFET with or without an external capacitor at GATE; Figures 2 and 3 show the related waveforms and timing diagrams (see Start-Up Time with $C_{BOARD} = 0$ and Start-Up Time with External C_{GATE} in the *Typical Operating Characteristics*). Remember that a high gate capacitance also increases the turn-off time.

When using the MAX4370 without an external gate capacitor, R_S is not necessary. R_S prevents MOSFET source oscillations that can occur when C_{GATE} is high while C_{BOARD} is low.

Case B: Fast Turn-On (with current limit)

In applications where the board capacitor (C_{BOARD}) at V_{OUT} is high, the inrush current causes a voltage drop across R_{SENSE} that exceeds the fast comparator threshold ($V_{FC,TH} = 200mV$). In this case, the current

charging C_{BOARD} can be considered constant and the turn-on time is determined by:

$$t_{ON} = C_{BOARD} \cdot V_{IN} / I_{FAST,SET}$$

where the maximum load current $I_{FAST,SET} = V_{FC,TH} / R_{SENSE}$. Figure 2 shows the waveforms and timing diagrams for a turn-on transient with current regulation (see Start-Up Time with $C_{BOARD} = 470\mu F$ in the *Typical Operating Characteristics*). When operating under this condition, an external gate capacitor is not required. Adding an external capacitor at GATE reduces the regulated current ripple but increases the turn-off time by increasing the gate delay (t_d) (Figure 3).

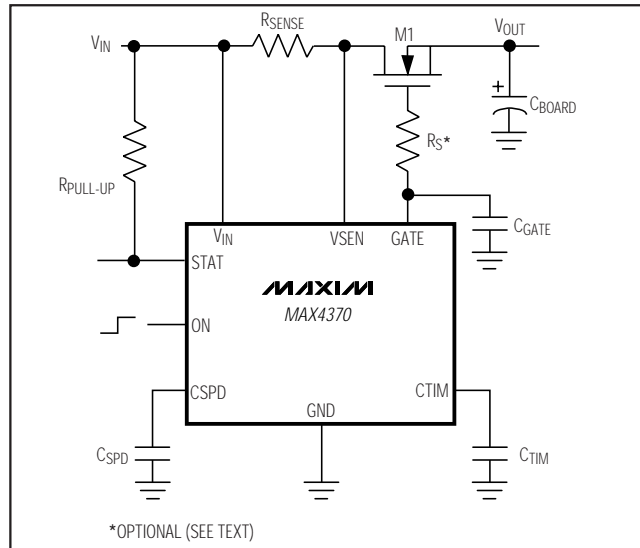

Figure 7. Operation with External Gate Capacitor

Table 4. MOSFET Turn-On Time (start-up without current limit)

($C_{BOARD} = 0$, turn-on with no load current, turn-off with 2A fault current)

DEVICE	C_{GATE} (nF)	MOSFET TURN-ON (t_{ON})			MOSFET TURN-OFF (t_{OFF})		
		$V_{IN} = 3V$	$V_{IN} = 5V$	$V_{IN} = 12V$	$V_{IN} = 3V$	$V_{IN} = 5V$	$V_{IN} = 12V$
Fairchild FDS6670A	0	220 μs	160 μs	190 μs	70 μs	130 μs	145 μs
	22	2.3ms	2ms	3.2ms	540 μs	1.1ms	1.95ms
International Rectifier IRF7401	0	175 μs	130 μs	160 μs	75 μs	130 μs	160 μs
	22	1.9ms	1.8ms	3.5ms	540 μs	1.1ms	2ms
Motorola MMSF5N03HD	0	101 μs	74 μs	73 μs	33 μs	67 μs	85 μs
	22	2ms	1.8ms	3.2ms	470 μs	1ms	1.95ms

Electrical characteristics as specified by the manufacturer's data sheet:

FDS6670A: $C_{ISS} = 3200pF$, $Q_{T(MAX)} = 50nC$, $R_{DS(ON)} = 8.2m\Omega$

IRF7401: $C_{ISS} = 1600pF$, $Q_{T(MAX)} = 48nC$, $R_{DS(ON)} = 22m\Omega$

MMSF5N03HD: $C_{ISS} = 1200pF$, $Q_{T(MAX)} = 21nC$, $R_{DS(ON)} = 40m\Omega$

Current-Regulating Hot-Swap Controller with DualSpeed/BiLevel Fault Protection

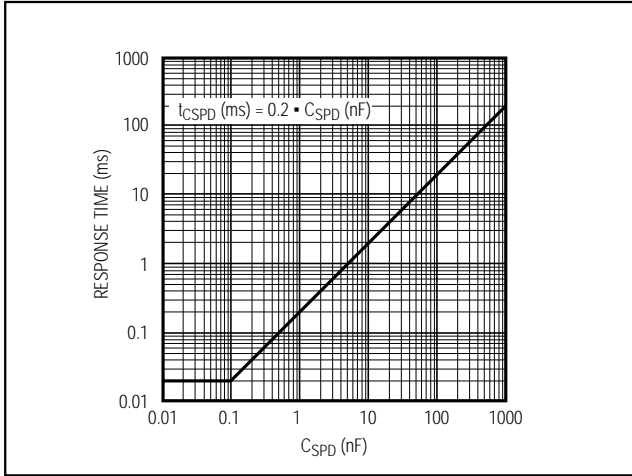

Figure 8. Slow Comparator Response Time vs. C_{SPD}

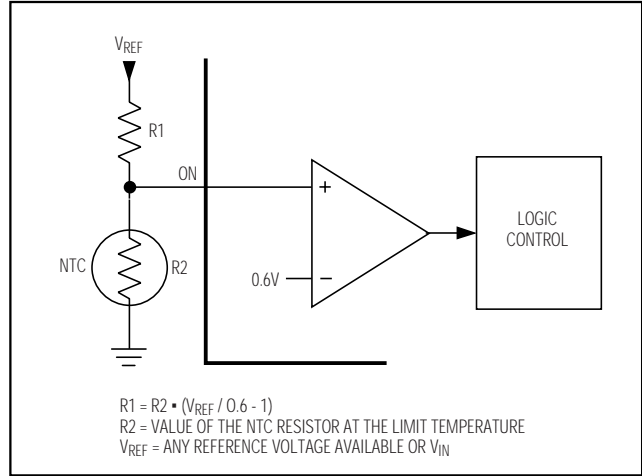

Figure 9. Temperature Monitoring and Protection

The actual turn-on time is determined by the longer of the two timings of Case A and Case B. Set the start-up timer (t_{START}) at $2 \cdot t_{ON}$ or longer to guarantee enough time for the output voltage to settle; also take into consideration device parameter variation.

Slow Comparator Response Time (C_{SPD})

The slow comparator threshold is set at 50mV, and its response time is determined by the external capacitor connected to C_{SPD} (Figure 8).

A minimum response time of 20 μ s (typ) is achieved by leaving this pin floating. This time is determined internally and is not affected by stray capacitance at C_{SPD} (up to 100pF).

Set the slow comparator response time to be longer than the normal operation load transients.

ON Comparator

The ON/OFF function of the MAX4370 is controlled by the ON comparator. This is a precision voltage comparator that can be used for temperature monitoring (Figure 9) or as an additional undervoltage lockout. The comparator threshold voltage is set at 0.6V with a 3mV typical hysteresis.

The ON comparator initiates start-up when its input voltage (V_{ON}) rises above the threshold voltage, and turns off the MOSFET when the voltage falls below the threshold. The ON comparator is also used to reset the MAX4370 after a fault condition.

The ON comparator input and the STAT output can be pulled to voltages up to 14V independently of V_{IN} .

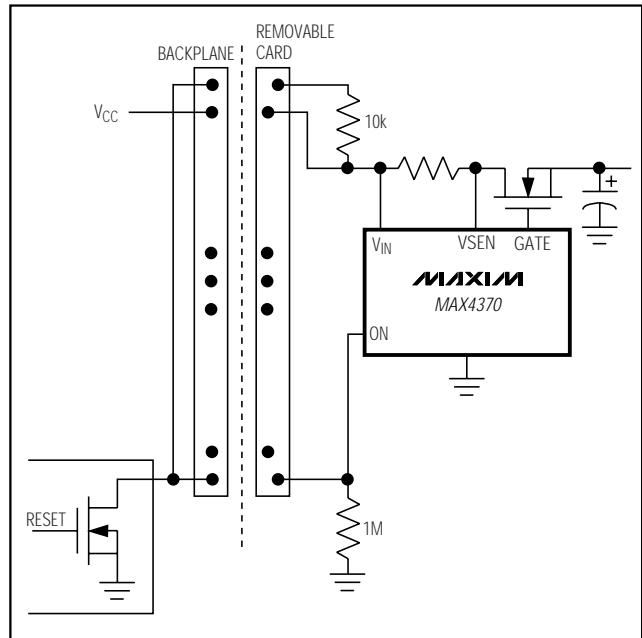

Figure 10. Fail-Safe Connector

In some applications, it is useful to use connectors with staggered leads. In Figure 10, the ON pin forces the removable board to be powered up only when all connections are made.

Current-Regulating Hot-Swap Controller with DualSpeed/BiLevel Fault Protection

Using the MAX4370 on the Backplane

The MAX4370 can be used on the backplane to regulate current upon insertion of a removable card. This allows multiple cards with different input capacitance to be inserted into the same slot even if the card doesn't have on-board hot-swap protection.

The MAX4370 current-limiting feature is active during the start-up period set by CTIM. The start-up period can be triggered if V_{IN} is connected to ON through a trace on the card. Once t_{START} has expired (timed out), the load capacitance has to be charged or a fault condition is detected. To ensure start-up with a fixed CTIM, t_{START} has to be longer than the time required to charge the board capacitance. The maximum load capacitance is calculated as follows:

$$C_{BOARD} < t_{START} \cdot I_{FAST,SET} / V_{IN}$$

Input Transients

The voltage at V_{IN} must be above the UVLO during inrush and fault conditions. When a short condition occurs on the board, the fault current can be higher than the fast comparator current limit. The gate voltage is discharged immediately, but note that the MOSFET is not completely off until V_{GS} < V_{TH}. If the main system power supply collapses below UVLO, the MAX4370 will force the device to restart once the supply has recovered. The main system power supply must be able to deliver this fault current without excessive voltage drop.

The MOSFET is turned off in a very short time; therefore, the resulting di/dt can be considerable. The backplane delivering the power to the external card must have a fairly low inductance to limit the voltage transients caused by the removal of a fault.

MOSFET Thermal Considerations

During normal operation, the MOSFET dissipates little power; it is fully turned on and its R_{DS(ON)} is minimal. The power dissipated in normal operation is P_D = (I_{LOAD})² · R_{DS(ON)}. A considerable amount of power is dissipated during the turn-on and turn-off transients. The design must take into consideration the worst-case scenario of a continuous short-circuit fault present on the board. Two cases must be considered:

- 1) The single turn-on with the device latched after a fault.
- 2) An external circuit forces a continuous automatic retry after the fault.

MOSFET manufacturers typically include the package normalized transient thermal resistance (r_{θJA}(t) or r_{θJC}(t)), which is determined by the start-up time and the retry duty cycle (d = t_{START} / t_{RETRY}). The following

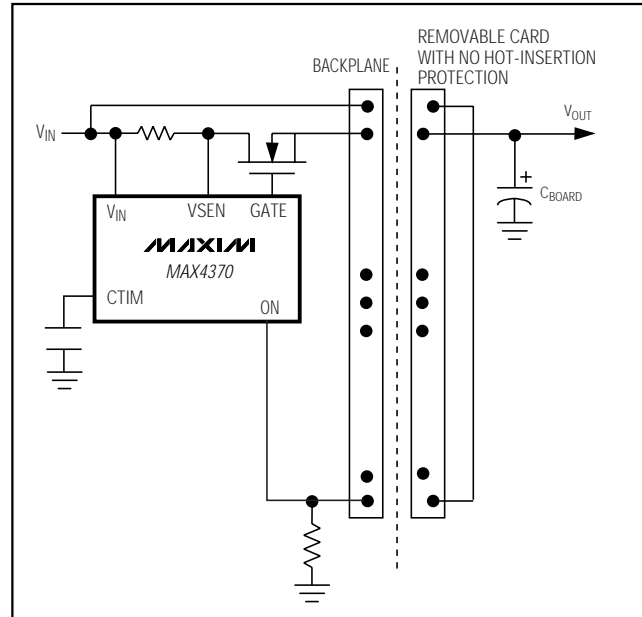

Figure 11. Using the MAX4370 on the Backplane

equation is used to calculate the required transient thermal resistance:

$$R_{\theta JA}(t) = (T_{J,MAX} - T_A) / P_{D,MAX}(t)$$

where P_{D,MAX}(t) = V_{IN} · I_{FAULT} and the resulting R_{θJA} = R_{θJA}(t) / r_{θJA}(t). R_{θJA} is the thermal resistance determined with a continuous load and by the layout or heatsink.

Layout Considerations

To take full advantage of the switch response time to an output fault condition, it is important to keep all traces as short as possible and to maximize the high-current trace dimensions to reduce the effect of undesirable parasitic inductance. Place the MAX4370 close to the card's connector. Use a ground plane to minimize its impedance and inductance.

Minimize the current-sense resistor trace length (<10mm), and ensure accurate current sensing with Kelvin connections (Figure 12).

When the output is short circuited, the voltage drop across the external MOSFET becomes large. Hence, the power dissipation across the switch increases, as does the die temperature. An efficient way to achieve good power dissipation on a surface-mount package is to lay out two copper pads directly under the package on both sides of the board. Connect the two pads to the ground plane through vias, and use enlarged copper mounting pads on the top side of the board.

Current-Regulating Hot-Swap Controller with DualSpeed/BiLevel Fault Protection

MAX4370

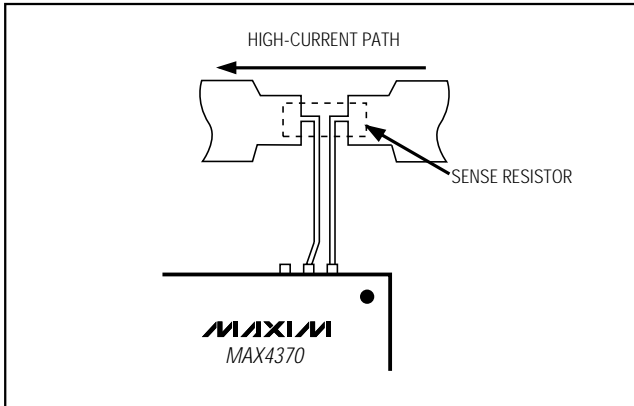
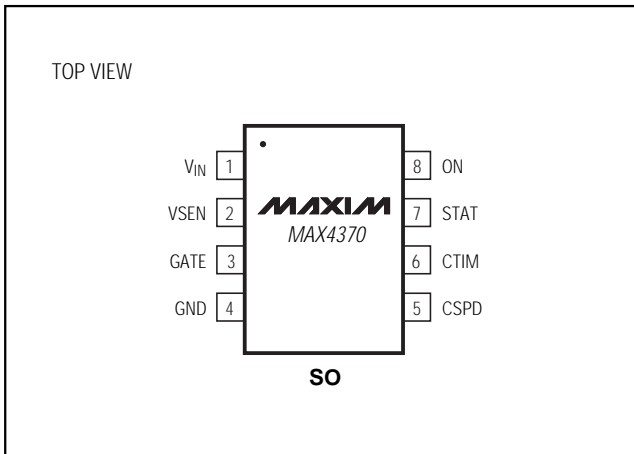

Figure 12. Kelvin Connections for the Current-Sense Resistors

Pin Configuration



Chip Information

TRANSISTOR COUNT: 1792

Current-Regulating Hot-Swap Controller with DualSpeed/BiLevel Fault Protection

Package Information

	INCHES		MILLIMETERS	
	MIN	MAX	MIN	MAX
A	0.053	0.069	1.35	1.75
A1	0.004	0.010	0.10	0.25
B	0.014	0.019	0.35	0.49
C	0.007	0.010	0.19	0.25
e	0.050		1.27	
E	0.150	0.157	3.80	4.00
H	0.228	0.244	5.80	6.20
h	0.010	0.020	0.25	0.50
L	0.016	0.050	0.40	1.27

	INCHES		MILLIMETERS		N	MS012
	MIN	MAX	MIN	MAX		
D	0.189	0.197	4.80	5.00	8	A
D	0.337	0.344	8.55	8.75	14	B
D	0.386	0.394	9.80	10.00	16	C

NOTES:
 1. D&E DO NOT INCLUDE MOLD FLASH
 2. MOLD FLASH OR PROTRUSIONS NOT TO EXCEED .15mm (.006")
 3. LEADS TO BE COPLANAR WITHIN .102mm (.004")
 4. CONTROLLING DIMENSION: MILLIMETER
 5. MEETS JEDEC MS012-XX AS SHOWN IN ABOVE TABLE
 6. N = NUMBER OF PINS

MAXIM
 120 SAN GABRIEL DR. SUNNYVALE CA 94086 FAX (408) 737-7754
 PROPRIETARY INFORMATION



PACKAGE FAMILY OUTLINE: SOIC .150" 1/1 21-0041 A
 TITLE DOCUMENT CONTROL NUMBER REV

Maxim cannot assume responsibility for use of any circuitry other than circuitry entirely embodied in a Maxim product. No circuitry patent licenses are implied. Maxim reserves the right to change the circuitry and specifications without notice at any time.

16 Maxim Integrated Products, 120 San Gabriel Drive, Sunnyvale, CA 94086 408-737-7600

Looking for pricing, stock, or lifecycle information?

Click below to explore more details on WIN SOURCE:

-  [View MAX4370ESA+T on WIN SOURCE](#)
-  [Maxim Integrated Information](#)

Optimize Your Supply Chain with WIN SOURCE Solutions

-  Global Sourcing Solution
-  Obsolete Management
-  Cost Control Management
-  Shortage Management
-  Alternative Solution
-  Excess Inventory Management